



This is a postprint version of the following published document:

Marotta, A., Cassioli, D., Kondepu. K., Antonelli, C., Valcarenghi, L. (2018). *Efficient Management of Flexible Functional Split through Software Defined 5G Converged Access*. Paper submitted in 2018 IEEE International Conference on Communications (ICC), Kansas City.

DOI: [10.1109/ICC.2018.8422555](https://doi.org/10.1109/ICC.2018.8422555)

©2018 IEEE. Personal use of this material is permitted. Permission from IEEE must be obtained for all other uses, in any current or future media, including reprinting/republishing this material for advertising or promotional purposes, creating new collective works, for resale or redistribution to servers or lists, or reuse of any copyrighted component of this work in other works.

Efficient Management of Flexible Functional Split through Software Defined 5G Converged Access

A. Marotta[•], D. Cassioli[•], K.Kondepu^{*}, C. Antonelli[•], L. Valcarenghi^{*}

[•]University of L'Aquila, L'Aquila, Italy

^{*}Scuola Superiore Sant'Anna, Pisa, Italy

Email:andrea.marotta@graduate.univaq.it

Abstract—Softwarization of mobile and optical networks facilitates the inter-working between control planes of the two domains, allowing a more efficient management of available resources. Radio resource utilization benefits from the centralization of mobile network functionalities with the application of high-order functional split options by fronthauling. However, higher-order options require larger bandwidth and lower latency in the fronthaul. Advanced mechanisms for the joint control of the access network represent the sole solution to support such fronthaul requirements. This paper proposes a new cooperation scheme to manage the adaptive flexible functional split in 5G networks conditioned to the resource availability in the optical access network. Results show that the proposed converged approach guarantees the optimal allocation of optical resources through a software defined wavelength and bandwidth allocation. The proposed scheme adapts to current traffic demand and simultaneously allows the mobile network to take advantage of the highest possible centralization of mobile network functions by leveraging flexible functional split adaptively compliant to the current optical traffic demand.

I. INTRODUCTION

The current scenario of Network of Networks in the 5G context poses several new challenges for the definition of network architectures, calling for new approaches to network management. Network softwarization enables the delivery of “network functionality via software running on industry-standard commercial off-the-shelf (COTS) hardware” and the programmability of network entities [1]. Additionally, network softwarization grants the highest level of flexibility in adapting the network architecture to the instantaneous network requirements, traffic load and users’ Quality of Service/Experience. Such flexibility stems from the possibility of splitting the network functionalities over several different planes. The simplest one is the “vertical functional split”, offered by the concept of Software Defined Networks (SDNs), which allows the separation of control plane and user plane providing a logically centralized control. In mobile networks, the centralization brings several gains, especially in terms of coordination for dynamic resource allocation. The degree of centralization can be varied operating what is called the “horizontal functional split” that allows a flexible allocation of network functions either in the central unit (CU) or in the distributed units (DUs), i.e. closer to the antenna sites [2], according to the concept of cloud radio access network (C-RAN).

Through the horizontal functional split, several architectures can be put in place dynamically, increasing and reducing

the level of centralization of functions and choosing the appropriate placement of mobile network functions according to current network requirements [3]. Interconnections between the CU and the DUs are provided by the fronthaul.

The horizontal functional split considers several possible splitting planes, which are standardized within the 3GPP [4]. Each proposed functional split sets specific latency and capacity requirements on the fronthaul, for which numerous transmission protocols are currently under investigation and standardization, e.g. CPRI, OBSAI, etc.

A promising approach, widely investigated, is the *flexible functional split* which permits to relax the excessive fronthaul requirements by distributing dynamically and flexibly the networks functionalities between the CU and the DUs [2], [3].

Flexible architectures or functional splits require appropriate advanced resource allocation mechanisms in both mobile, access and core networks. Passive Optical Networks (PONs) have been proposed as a possible fronthaul infrastructure due to the high availability in urban scenarios and low OPERational EXpenditures (OPEX) [5]. A converged scheme for joint Dynamic Bandwidth Allocation (DBA) over mobile and time-division multiplexing passive optical network (TDM-PON) has been proposed in [6]. Proper time slots are allocated in the TDM-PON by cooperating with mobile scheduling based on the estimated arrival time of data. It allows uplink transmission on mobile fronthaul with a latency of about 137 μ s. However, it requires strict coordination between the CU and the user equipment (UE) to exchange mobile scheduling information.

A Flexible Access System Architecture (FASA) platform, which allows software-based modularity of functions to support different add-on services such as enterprise, wireless and mobile, has been proposed by NTT [7]. FASA also supports add-on modules for different optical technologies depending on the required transfer capacity.

Converged management schemes over different domains bring significant advantages. For instance, Core and Radio Access Networks rely on Software Defined Mobile Network (SDMN) approach [8] to apply an advanced joint management of resources, spectrum and mobility, and to boost the cooperation among heterogeneous networks. The optical access domain makes use of Software Defined Access (SDA) with special focus on the integration between Access and Aggregation networks [9].

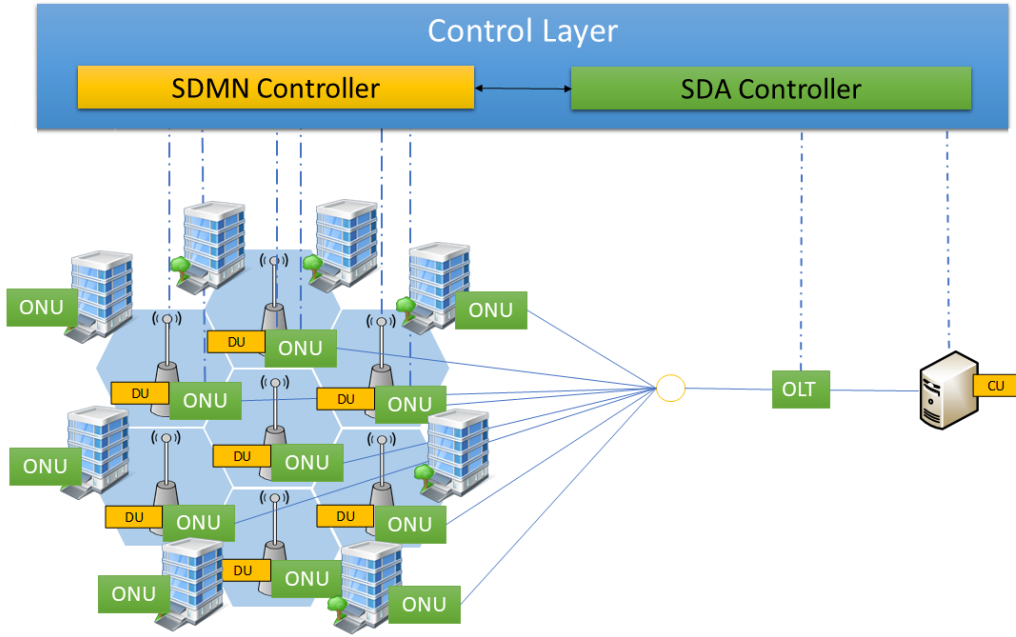

Figure 1. System Model

We proposed a new SDA and SDMN integrated framework for a PON-based fronthauling solution in [10] and [11], where we demonstrated that the novel devised Software Defined Wavelength Bandwidth Allocation (SD-WBA) scheme, which exploits the exchange of cell status information between mobile and fixed access, brings a significant gain in terms of both performance and cost.

In this paper, we investigate the potential of the SD-WBA approach to support the adaptive application of *flexible functional split* options according to the current traffic load in the network. The SDMN controller applies the functional split option that corresponds to the highest possible centralization degree in the mobile network, which is allowed by the SDA according to the current capability of the optical network of efficiently accommodating both the associated fronthaul traffic and the regular traffic.

Hence, we define a new cooperation scheme for the interworking of the SDA controller and the SDMN controller, such that the fast re-configuration and distribution of network functions between CU and DUs in the mobile network (i.e., the implementation of the currently most appropriate functional split option) is driven by the SD-WBA management scheme.

The results show that the proposed converged approach allows to efficiently address the regular traffic demand in the PON, simultaneously providing the maximum possible benefit to the mobile network by granting the highest possible degree of centralization of mobile functions permitted by the current traffic conditions in the PON.

II. SYSTEM MODEL

In this work we consider the reference architecture shown in Fig. 1 where several DUs are deployed in a urban scenario and are connected to the CU through a Time and Wavelength Division Multiplexing PON (TWDM-PON). The DUs are equipped with an ONU while the CU is connected to the OLT at the central office site. The PON is also utilized as *Fiber To The X* (FTTx) infrastructure for other services such as residential and business connectivity and Internet of Things (IoT).

The optical infrastructure is managed by a SDA controller which interacts with the agents placed at the OLT and ONUs. The SDA controller is responsible of Dynamic Wavelength and Bandwidth Allocation, Wavelength activation/deactivation and integrated QoS management with the metro network. Moreover, it exposes optical access network parameters to other Software Defined Network Controllers implementing the so called west-bound interface that allows convergence among different control planes [12].

The SDMN controller is in charge of making decisions regarding the mobile network. It is responsible of Radio Resource Management (RRM), cells activation/deactivation, cooperation among DUs and mobile network function placement. As well as the SDA controller, the SDMN controller enables integrated mobile-optical control mechanisms through the means of the west-bound interface.

The exchange of information between optical and mobile controllers is exploited on one hand to implement a SD-WBA in the PON to support fronthauling and on the other hand to dynamically adapt the Functional Split (FS) between the CU and DU based on the bandwidth available for the fronthaul.

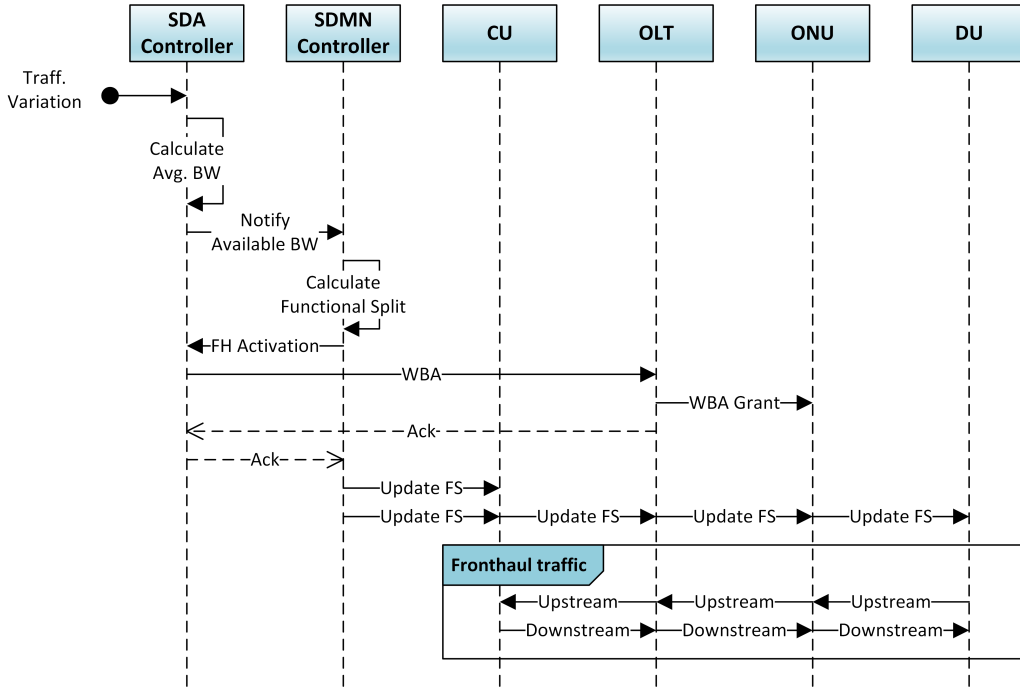

Figure 2. Converged SD-WBA and flexible functional split

As shown in [4], different functional split options imply different requirements for the fronthaul segment in terms of data-rate and delay budget. The requirements of the fronthaul segment have a direct impact on the WBA scheme to be adopted in the PON. DBA schemes based on report-grant mechanisms, although more efficient in terms of bandwidth utilization, are not suitable for higher functional split requiring less than $250 \mu s$ delay. Fixed Bandwidth Allocation (FBA) represents a feasible solution to guarantee low latency and assured bandwidth. However, it could result in inefficient bandwidth utilization since it allocates a fixed amount of bandwidth even when it is not required by the DUs.

The SDA controller implements a SD-WBA that allocates bandwidth and wavelengths for bearing DU-CU communications according to the fronthaul requirements. It allocates fixed bandwidth for low latency split options (4-8) and activates dynamic report-grant based bandwidth allocation for non latency-critical split options (1-3). In this work, we assume that the OLT implements FBA and DBA schemes able to meet latency and bandwidth requirements for different split options.

From the mobile network perspective, as shown in Fig. 2 the SDMN controller is informed by the SDA controller about the amount of bandwidth available in the PON to implement the fronthaul. The SDMN controller runs a *functional split calculation algorithm* that selects the best suitable FS to be deployed matching the bandwidth currently available. A fronthaul activation command is sent to the SDA controller specifying the requirements in terms of bandwidth and maximum latency. The SDA controller instructs the OLT to implement the appropriate wavelength and bandwidth allocation for the ONUs serving the DUs.

Once the SDMN is acknowledged about the fronthaul segment bandwidth reservation, it communicates with the CU and the DUs in order to update the functional split. Finally, the fronthaul traffic of the new functional split can start to flow.

A. Functional split calculation algorithm

To select the best suitable functional split to be dynamically implemented, such algorithm represents a key functionality in the flexible functional split architecture. We propose a simple strategy that allocates the same functional split to all the DUs connected to the same CU. It is important to notice that, although higher split options are more demanding in terms of bandwidth and latency, they enable to leverage centralization advantages in terms of resources allocation, cooperative transmission and QoS management. Therefore, the objective of the proposed strategy is to maximize the centralization of functionalities operating the highest functional split based on the available bandwidth in the optical PON-based fronthaul.

The available bandwidth in the PON varies during time due to the coexistence with other services, i.e. residential FTTH, business connectivity and IoT devices. Therefore, the illustrated algorithm is run everytime the SDMN controller is notified about a bandwidth's variation. We can define the available bandwidth as:

$$B_{AV}[\text{Mbps}] = B_{TOT}[\text{Mbps}] - B_{Other}[\text{Mbps}] \quad (1)$$

where:

- $B_{AV}[\text{Mbps}]$ is the available bandwidth that could be granted to the fronthaul
- $B_{TOT}[\text{Mbps}]$ is the total bandwidth of the TWDM-PON

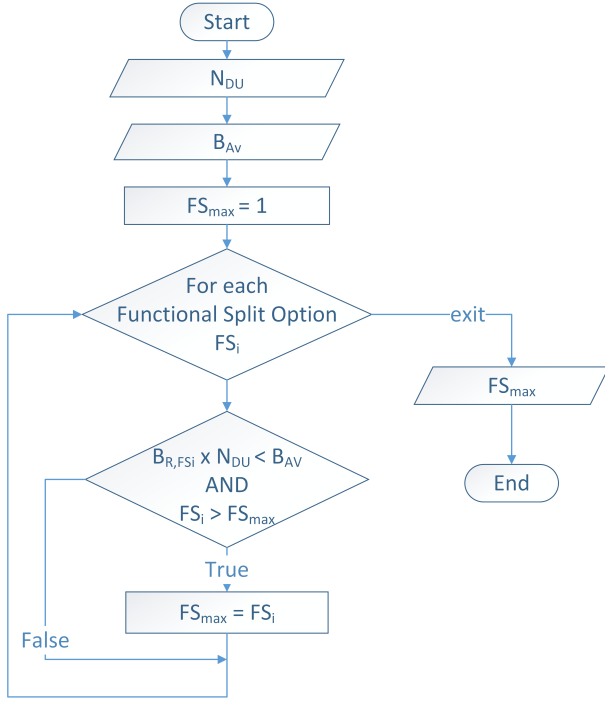

Figure 3. Functional split calculation algorithm

- $B_{Other[Mbps]}$ is the time-varying bandwidth required by non-mobile services

The problem of individuating the functional split with the highest centralization level FS_{max} at time t can be formalized as:

$$\begin{aligned}
 FS_{max} = \max \quad & FS_i \\
 \text{subject to} \quad & B_{R,FS_i[Mbps]} \times N_{DU} < B_{AV[Mbps]} \quad (2) \\
 & i \in \{1, \dots, 8\}
 \end{aligned}$$

Where:

- FS_{max} is the maximum achievable functional split
- FS_i is the i -th functional split option, as listed in Table I
- B_{R,FS_i} is the bandwidth required by FS_i
- N_{DU} is the number of DUs
- B_{AV} is the available bandwidth at the time t

The above illustrated problem can be solved by applying the algorithm shown in Fig. 3. The proposed algorithm takes as input the value of the bandwidth available in the PON, B_{AV} , provided by the SDA controller and iterates over all possible functional split options. At each iteration it evaluates both the feasibility condition, i.e. if there is enough bandwidth to implement the specified functional split FS_i , and the maximality condition, i.e. if the functional split is the highest possible. As output, at the end of the iteration, the highest functional split FS_{max} that is supportable by the optical network is selected.

III. PERFORMANCE EVALUATION AND RESULTS

The scenario adopted for the simulation is represented by an urban area where 8 DUs are deployed and connected

Table I
SPLIT OPTIONS REQUIREMENTS

Split option	UL [Mbps]	DL [Mbps]	Max delay	Bandwidth allocation
1	50	150	10ms	Dynamic
2	74	166	1.5*10 ms	Dynamic
3	74	166	1.5*10 ms	Dynamic
4	196	75	~100 μ s	Fixed
5	119	211	hundreds of μ s	Fixed
6	119	211	250 μ s	Fixed
7a	666	479	250 μ s	Fixed
7b	3017	472	250 μ s	Fixed
7c	3017	479	250 μ s	Fixed
8	4800	4800	250 μ s	Fixed

using a PON based fronthaul infrastructure. The fronthaul segment is implemented through a TWDM-PON with four wavelengths pairs. Wavelengths support 10 Gbps symmetric upstream/downstream data rate. The TWDM-PON is utilized also as access infrastructure for other services characterized by the time-variant upstream traffic load illustrated in Fig. 4. Regarding fronthaul requirements we consider the values shown in Table I that are adapted from [4] considering DUs offering LTE 20MHz MIMO 2x2. Moreover, we assume the SDA controller providing an estimation of the available bandwidth to the SDMN controller every 30 minutes. The numerical evaluation is performed in MATLAB environment.

As it can be noticed the highest bandwidth requirement is obtained with split option 8 that is 4,8 Gbps. Since each wavelength supports at the maximum 10 Gbps, this means that in ideal conditions we can accommodate at the maximum 8 DUs in the TWDM-PON.

Fig. 5 shows the variation of functional splits during the day obtained adopting the proposed converged approach. In the following we compare the flexible functional split with a fixed approach where static hardware implements a specific split option. Results show that the functional split ranges between

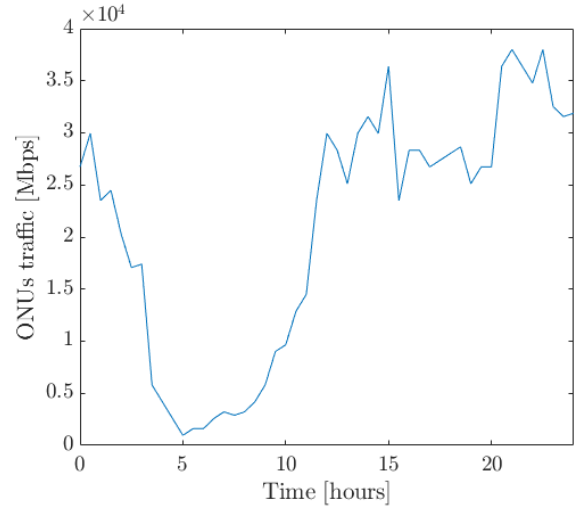

Figure 4. ONUs non-mobile aggregated traffic

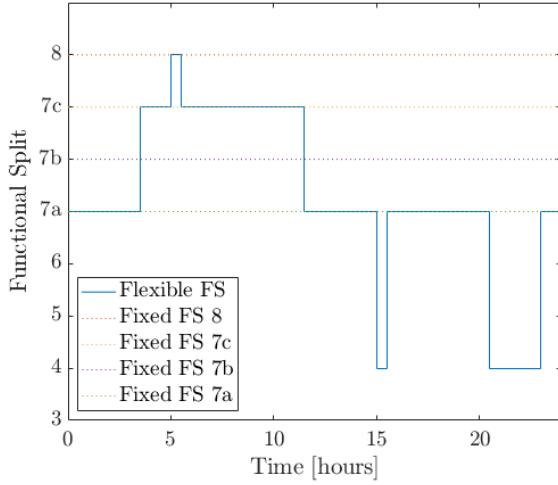

Figure 5. Effective functional split

option 8 and 4, i.e. from RF-PHY to MAC-RLC split. It can be noticed that, when the traffic required by the other services in the PON increases, the functional split is scaled down in order to reduce the required bandwidth, preventing a degradation of the QoS offered from the PON to the other services. On the other hand, when the traffic in the PON decreases, more functionalities are centralized and higher functional splits are implemented.

With respect to the illustrated scenario one can notice that during the largest portion of the day functional splits options 7a and 7c are mostly adopted. Although not all the centralization advantages of option 8 are exploited, these represent a good compromise between centralization and bandwidth utilization. The main advantage of these two functional split options is that traffic aggregation from transmission points can be centralized, i.e. the MAC resides in CU, hence centralized scheduling and joint processing can be applied. In fact, in option 7a inverse Fast Fourier Transform (iFFT) and Cyclic Prefix addition/removal functions reside in the DU while the rest of PHY functions reside in the CU. Moreover, in option 7c only the encoder resides in the CU, and the rest of PHY functions reside in the DU.

As highlighted in Table I, higher functional splits require fixed bandwidth reservation in order to meet delay requirements. This means that when the maximum bandwidth occupancy is reached in the PON, fronthaul traffic bandwidth cannot be reduced dynamically. On the other hand this implies a degradation of the traffic related to other services flowing in the PON. In Fig. 6 we compare the performance of different fixed functional splits options with the proposed flexible functional split approach focusing on the performance impact on the other supported services. We define the *service fulfillment index* η as the ratio between the achieved throughput and the required bandwidth for the ONUs offering non-mobile

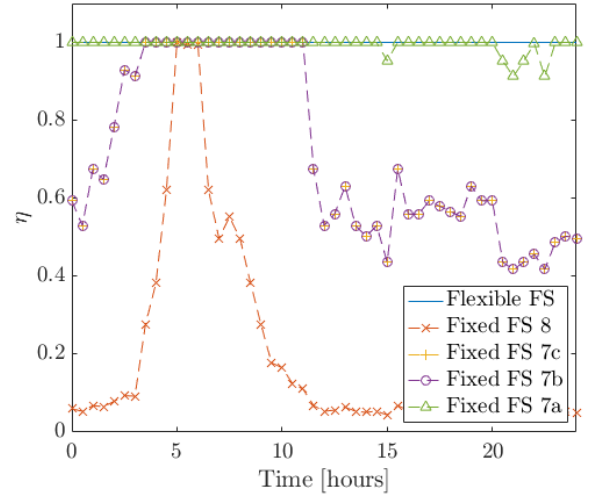

Figure 6. Service fulfillment comparison

services. Therefore, η is calculated as:

$$\eta = \frac{R_{Other[Mbps]}}{B_{Other[Mbps]}} \quad (3)$$

where:

- η is the service fulfillment index
- $R_{Other[Mbps]} = B_{TOT} - B_{R,FS} \times N_{DU}$ is the achieved non-mobile aggregated ONU throughput
- $B_{Other[Mbps]}$ is the total bandwidth required by the non-mobile services

Therefore, $0 \leq \eta \leq 1$. If the requested bandwidth is totally granted to the non-mobile services, $R_{Other} = B_{Other}$ and η is equal to 1. If $\eta \leq 1$, $R_{Other} \leq B_{Other}$ and the performance of non-mobile services is impaired by fronthaul traffic.

Results show that the flexible functional split allows to efficiently address the demand of traffic in the PON, even in the presence of the heaviest traffic loads. Instead, the other fixed functional splits lead to a performance degradation of other supported services to which only a fraction of required bandwidth can be granted. Indeed, when fixed functional split 8 is implemented, only 5% of the required bandwidth is offered to non-mobile services in peak hours. Options 7b and 7c achieve 7 hours without degradation of service but offers only 40% of the required bandwidth during peak hours. Finally, small degradation of service is experienced also with fixed split 7a. For the sake of readability only results related to split options 8, 7c, 7b and 7a are plotted. Options 1-6 achieve 100% of bandwidth availability but do not benefit of the centralization advantages of the the proposed converged flexible functional split approach.

IV. CONCLUSION

In this work we proposed a converged approach between SDMN and SDA for joint control of flexible functional split and wavelength and bandwidth allocation in TWDM-PON fronthauling. We illustrated a functional split selection strategy