

---

---

# UAV PLANNING, AUTONOMOUS TRACKING, AND OBSTACLE IDENTIFICATION AND AVOIDANCE

---

---

By

ÁLVARO MELGOSA PASCUAL



Department of Bioengineering and Aerospace Engineering  
UNIVERSIDAD CARLOS III DE MADRID

SEPTEMBER 2016

Supervisors:  
Manuel Soler Arnedo  
Xin Chen



## ABSTRACT

The large growth that the civil Unmanned Aerial Vehicles (UAVs) market has experienced in the last decade is now triggering the urge of both professionals and enthusiasts to use this technology to perform tasks that would be more difficult to accomplish with their traditional procedures. However, many times these tasks require precision flight and do not allow the slightest physical contact of the UAV with its surroundings. Currently, very qualified pilots are needed since there have not been significant advancements on on-board obstacle detection technologies, and manual control is still a must.

The main goal of this thesis is to develop an affordable Obstacle Alert and Collision Avoidance System (OCAS) that can be easily deployed to a wide range of UAVs. The approach followed is to embark a series of ultrasonic rangefinders to continuously monitor the minimum distance of the vehicle with its surroundings. The data provided by the sensors is then processed on an onboard computer, and control commands are sent to the main controller board in the case that an obstacle is detected and a possible collision identified. The final result is an integrable payload subsystem that would improve the situational awareness capabilities of any UAV that integrates it, reducing the risk of collision with its surroundings.

**Keywords:** UAV, obstacle detection, collision avoidance, system integration, ultrasonic rangefinder, Ardupilot



## DEDICATION AND ACKNOWLEDGEMENTS

**F**irstly, I would like to dedicate this thesis to my family, who have always supported me and are making a big effort to provide me with the best education.

Secondly, a big thank you to Xin Chen, who not only was the person which I could discuss technical issues with, but also motivated me every day through her endless optimism. Thank you also to Manuel Soler for trusting on my progress even though he was not aware of the state of the most technical parts of the project.

And last but not least, my appreciation for all my friends and classmates at UC3M, who accidentally excited me to keep working by showing their most sincere interest on the topic I was working on.



## TABLE OF CONTENTS

	Page
Abstract . . . . .	ii
Dedication and Acknowledgements . . . . .	iv
Table of Contents . . . . .	v
List of Figures . . . . .	ix
List of Tables . . . . .	xi
List of Acronyms . . . . .	xiii
<b>1 Introduction</b>	<b>1</b>
1.1 Background information . . . . .	1
1.2 Socioeconomic environment . . . . .	2
1.3 Legal framework . . . . .	3
1.4 Motivation . . . . .	3
1.5 Project objectives . . . . .	4
1.6 Methodology . . . . .	5
1.7 Time planning . . . . .	5
1.8 Budget . . . . .	5
1.8.1 Personnel expenses . . . . .	5
1.8.2 Software cost . . . . .	7
1.8.3 Hardware cost . . . . .	7
<b>2 State of the art</b>	<b>9</b>
2.1 Environment sensing . . . . .	9
2.1.1 Radar . . . . .	9
2.1.2 Sonar . . . . .	10
2.1.3 Lidar . . . . .	11
2.1.4 Computer vision . . . . .	11
2.2 Collision avoidance . . . . .	11
2.2.1 TCAS on conventional aircraft . . . . .	12
2.2.2 DJI Phantom 4 . . . . .	12
<b>3 A brief introduction to Ardupilot</b>	<b>15</b>

## TABLE OF CONTENTS

---

3.1	Basic features . . . . .	15
3.2	Ardupilot as part of a UAS . . . . .	16
3.3	Advanced features . . . . .	18
3.3.1	Flight modes . . . . .	18
<b>4</b>	<b>Problem statement</b>	<b>21</b>
<b>5</b>	<b>System design</b>	<b>23</b>
5.1	Requirements capture . . . . .	24
5.2	Logical Decomposition . . . . .	26
5.2.1	Functional Architecture . . . . .	26
5.2.2	Functional Flow Block Diagram (FFBD) . . . . .	26
5.2.3	Product Breakdown Structure (PBS) . . . . .	30
5.2.4	Functional-Physical matrix . . . . .	30
5.2.5	Interfaces definition (N <sup>2</sup> diagram) . . . . .	31
<b>6</b>	<b>System implementation</b>	<b>35</b>
6.1	The OCAS within the UAS . . . . .	35
6.1.1	Overview of the existing UAS . . . . .	35
6.1.2	Integration of the OCAS . . . . .	36
6.2	Component choice . . . . .	37
6.2.1	Sensors . . . . .	37
6.2.2	Computer board . . . . .	39
6.2.3	Other components . . . . .	40
6.3	OCAS peripheral connections (hardware interfaces) . . . . .	40
6.3.1	Power connection . . . . .	41
6.3.2	MAVlink connection . . . . .	41
6.3.3	GCS connection . . . . .	41
6.3.4	GPIO connection . . . . .	42
6.4	Software: Bringing everything together . . . . .	44
6.4.1	The Operating System . . . . .	44
6.4.2	MAVproxy . . . . .	45
6.4.3	The Python environment . . . . .	46
6.5	The Python script . . . . .	47
6.5.1	Script architecture . . . . .	48
6.5.2	Multi-threading capabilities . . . . .	48
6.5.3	Log information . . . . .	48
6.5.4	Connect to UAV . . . . .	50
6.5.5	Observe state . . . . .	50



6.5.6	Take control of UAV . . . . .	52
6.5.7	Avoid obstacle . . . . .	53
6.5.8	Return control to the pilot . . . . .	54
6.5.9	The “main” file . . . . .	54
6.6	Graphical User Interface . . . . .	54
6.7	Hardware implementation . . . . .	55
<b>7</b>	<b>Testing and results</b>	<b>59</b>
7.1	Testing methods . . . . .	59
7.1.1	Component testing . . . . .	59
7.1.2	Software testing: SITL . . . . .	61
7.1.3	System testing . . . . .	62
7.2	Results . . . . .	63
7.2.1	Ultrasonic rangefinders . . . . .	63
7.2.2	Simulator . . . . .	64
7.2.3	UAS + OCAS . . . . .	65
<b>8</b>	<b>Conclusions</b>	<b>69</b>
8.1	Summary of contributions . . . . .	70
8.2	Future work . . . . .	71
<b>A</b>	<b>Creation of GCS wireless network</b>	<b>73</b>
<b>B</b>	<b>SSH connection with the GCS</b>	<b>75</b>
<b>C</b>	<b>Technical documentation of the HC-SR04 rangefinder</b>	<b>79</b>
<b>D</b>	<b>Threads.py</b>	<b>83</b>
<b>E</b>	<b>Logging setup</b>	<b>85</b>
<b>F</b>	<b>Connect.py</b>	<b>87</b>
<b>G</b>	<b>Sonar.py</b>	<b>89</b>
<b>H</b>	<b>Control.py</b>	<b>93</b>
<b>I</b>	<b>Auto.py</b>	<b>97</b>
<b>J</b>	<b>Main.py</b>	<b>99</b>
<b>K</b>	<b>Temperature sensitivity of ultrasonic rangefinders</b>	<b>105</b>

## TABLE OF CONTENTS

---

<b>L GUI.pyw</b>	<b>107</b>
<b>M Raspberry Pi's interfaces configuration</b>	<b>111</b>
<b>N SonarDriver.py</b>	<b>113</b>
<b>O Channel 7 script trigger</b>	<b>115</b>
<b>P Observe.py</b>	<b>117</b>
<b>Bibliography</b>	<b>121</b>

## LIST OF FIGURES

FIGURE	Page
1.1 Distribution of potential UAV markets [31] . . . . .	2
1.2 Gantt Diagram of the Project . . . . .	6
2.1 Highly directional radiation pattern. Source: <a href="http://cisco.com">cisco.com</a> . . . . .	10
2.2 The stereo matching problem Source: [9] . . . . .	12
2.3 DJI Phantom 4 with stereo camera OCAS . . . . .	13
3.1 FlySky FS-i6 Remote Control ( <a href="http://www.flyskyr.com">www.flyskyr.com</a> ) . . . . .	16
3.2 Screenshot of Mission Planner GCS, implementing the MAVlink protocol . . . . .	17
3.3 Vehicle configurations supported by Ardupilot . . . . .	19
5.1 Cost to fix a design error. Source: [29] . . . . .	23
5.2 The Logical Decomposition phase . . . . .	26
5.3 OCAS Functional Architecture . . . . .	27
5.4 Symbology used for the FFBDs . . . . .	27
5.5 OCAS Functional Flow Block Diagram. TOP LEVEL . . . . .	28
5.6 OCAS Functional Flow Block Diagram. 1 <sup>st</sup> STAGE . . . . .	28
5.7 OCAS Functional Flow Block Diagram. 3 <sup>rd</sup> STAGE . . . . .	28
5.8 OCAS Functional Flow Block Diagram. 4 <sup>th</sup> STAGE . . . . .	29
5.9 OCAS Functional Flow Block Diagram. 5 <sup>th</sup> STAGE . . . . .	29
5.10 OCAS Functional Flow Block Diagram. 6 <sup>th</sup> STAGE . . . . .	29
5.11 OCAS Product Breakdown Structure . . . . .	30
5.12 Example of a N <sup>2</sup> diagram . . . . .	32
5.13 OCAS N <sup>2</sup> diagram for interfaces definition . . . . .	33
6.1 Regular Ardupilot UAS architecture . . . . .	36
6.2 OCAS-equipped UAS architecture . . . . .	37
6.3 Chosen ultrasonic rangefinder: HC-SR04. Source: <a href="http://arduinolearning.com">arduinolearning.com</a> . . . . .	39
6.4 Raspberry Pi 2 Model B. Source: <a href="http://raspberrypi.org">raspberrypi.org</a> . . . . .	39
6.5 Testing platform, with OCAS already integrated . . . . .	40
6.6 OCAS hardware layout . . . . .	41

6.7	GPIO pins on the Raspberry Pi 2 model B Source: raspberrypi.org . . . . .	43
6.8	Schematic of a voltage divider . . . . .	43
6.9	Connection of the HC-SR04 sensor to the Raspberry Pi . . . . .	43
6.10	Software architecture of the OCAS computer . . . . .	44
6.11	MAVproxy setup . . . . .	45
6.12	Functional flow diagram of the Python script . . . . .	49
6.13	Prediction of a collision by the OCAS . . . . .	53
6.14	Graphical User Interface . . . . .	55
6.15	Default F450 configuration. Source: rcgroups.com . . . . .	56
6.16	Final platform architecture . . . . .	56
7.1	Testing obstacle . . . . .	62
7.2	Ultrasonic rangefinder FOV test setup . . . . .	63
7.3	Initial testing site within the city . . . . .	65
7.4	Results of the flight test . . . . .	66

## LIST OF TABLES

<b>TABLE</b>	<b>Page</b>
1.1 Prototype hardware costs . . . . .	7
3.1 Summary of the relevant flight modes . . . . .	19
5.1 OCAS System-level Requirements . . . . .	25
5.2 OCAS Functional-Physical matrix . . . . .	31
6.1 Sensor alternatives trade-off study . . . . .	38
6.2 Functional and component allocation matrix . . . . .	47



## LIST OF ACRONYMS

<b>UAV</b>	Unmanned Aerial Vehicle
<b>UAS</b>	Unmanned Aerial System
<b>RPAS</b>	Remotely Piloted Aircraft System
<b>MAV</b>	Micro Aerial Vehicle
<b>OCAS</b>	Obstacle Collision Avoidance System
<b>TCAS</b>	Traffic alert and Collision Avoidance System
<b>GCS</b>	Ground Control Station
<b>RTL</b>	Return To Launch
<b>VLOS</b>	Visual Line Of Sight
<b>BVLOS</b>	Beyond Visual Line Of Sight
<b>RADAR</b>	RAdio Detection And Ranging
<b>SONAR</b>	SOund Navigation And Ranging
<b>LIDAR</b>	LIght Detection And Ranging
<b>FFBD</b>	Functional Flow Block Diagram
<b>PBS</b>	Product Breakdown Structure
<b>SITL</b>	Software In The Loop
<b>RC</b>	Radio Control
<b>PWM</b>	Pulse Width Modulation
<b>IMU</b>	Inertial Measurement Unit
<b>GPS</b>	Global Positioning System
<b>SBC</b>	Single Board Computer
<b>RPi</b>	Raspberry Pi
<b>USB</b>	Universal Serial Bus
<b>SSH</b>	Secure SHell
<b>GPIO</b>	General Purpose Input / Output
<b>GND</b>	Ground
<b>VCC</b>	Voltage of Continuous Current
<b>API</b>	Application Programming Interface
<b>GUI</b>	Graphical User Interface
<b>TRL</b>	Technology Readiness Level





## INTRODUCTION

The aim of this Chapter is to acquaint the reader with the emerging UAV (Unmanned Aerial Vehicle) market, and the challenges it is facing on its way towards maturity. Also, the reasons for its rapid evolution will be exposed and finally, focusing on the contents of this thesis, the personal motivation and the methodology will be explained to further expand on the topics of interest in the following chapters.

## 1.1 Background information

The first remotely radio controlled models appeared in the early twentieth century as small prototypes for potential manned aircraft. Afterwards, and during most of the century, the investigation and development lines were directed towards the military scope, in which the main objective of UAVs, which is still applied today, was to substitute manned aircraft in three types of military operations, commonly known as “the three D’s” [12, 5]:

- Dirty: operations performed in a contaminated environment.
- Dangerous: operations entailing some risk for the pilot.
- Dull: long and monotone operations, such as monitoring operations.

In the 70’s and the 80’s, efforts were directed to improve the technical characteristics of these vehicles. But it was not until the late 80’s when a revolution in the industry took place with the introduction of the GPS navigation system, whose accuracy in geolocation opened a whole new spectrum of possibilities.

Regarding the civil sector, the potential applications of UAVs in the non-military field are much more diverse. Nowadays these vehicles are in the process of finding new niche positions

in the civilian market, having been introduced up to now in different industry sectors such as agriculture, forest fire fighting, search and rescue, aerial photography, cartography, or security and surveillance, among others. Despite the latter, the use of UAVs for civil purposes is relatively recent in comparison with the military sector. This late implementation in the civilian field was caused mainly by two limitations which are of minor relevance in the fighting industry: economy and legislation. [3]

## 1.2 Socioeconomic environment

Apart from “the three D’s” mentioned in Section 1.1, another reason for the embracement of UAVs within the industry shall be considered. The final goal of any company is to create profit to their shareholders, which can be done either by increasing the revenues or by decreasing the costs of their activities. UAVs enter in the latter category. The consistent usage of smaller tools as compared with the manned workpower usually means that the equipment costs can be lowered, as well as the man-hours needed to perform the task [4], not to mention that most of the time the number of workers needed can be reduced to as low as one or two, in charge of operating the UAS (Unmanned Aerial System<sup>1</sup>).

This phenomenon is already proving to be very effective for the companies taking advantage of it, but research also shows an even bigger potential that is still waiting to be exploited, claiming that UAVs could have replaced \$127 billion worth of human labour in 2015 [31], distributed in the sectors shown in Figure 1.1.

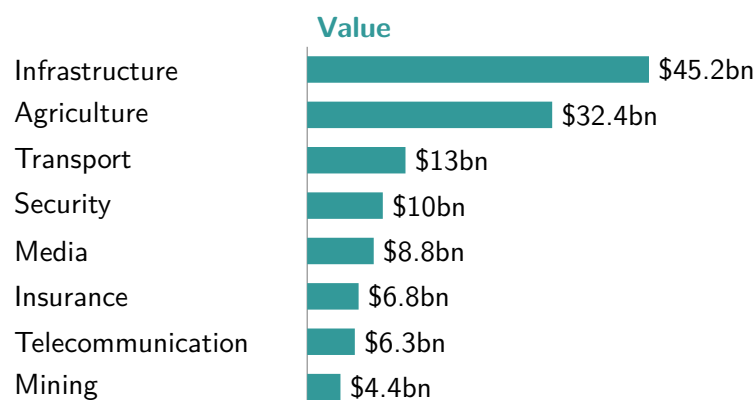

Figure 1.1: Distribution of potential UAV markets [31]

---

<sup>1</sup>UAS refers to the bigger system that incorporates one or more UAVs, as well as the Ground Control Station and other related subsystems

## 1.3 Legal framework

Due to the fast-evolving UAV industry, the aviation authorities have not yet been able to develop a reasonable set of regulations and standards to harmonize the legislation across borders. Additionally, this regulatory framework should consider the idea that each system has unique capabilities and characteristics and also that development and innovation are very important concepts in the field, and should not be dampened by restrictive rules [30]

However, there have already been some efforts from ICAO to outline some general rules to give a global sense of what is expected from the UAV sector [20]. In addition to that, some countries are creating their own legislation to enable the operation of Unmanned Aerial Vehicles within their territory.

For example, the Spanish government issued an urgent provisional regulation on October 2014 [2] that affects to Remotely Piloted Aircraft Systems (RPAS<sup>2</sup>) not exceeding 150 kg of Maximum Take Off Mass (MTOM). Heavier UAVs are subjected to European regulations [14] Focusing on the smaller segments, UAVs are separated according to their MTOM as follows:

**MTOM < 2 kg:** Flights Beyond Visual Line Of Sight (BVLOS) are allowed, but conditioned to the publication of a NOTAM (NOtice To AirMen). Apart from that, all the other rules in the 2 kg to 25 kg apply.

**2 kg ≤ MTOM < 25 kg:** Only operable in areas separated from groups of buildings in cities, or groups of people elsewhere. Flight shall always take place in uncontrolled airspace, within Visual Line Of Sight (VLOS) and at a maximum distance of 500 m from the position of the pilot, not exceeding 400 ft of height over the terrain.

**25 kg < MTOM:** Flight is only allowed for firefighting, search and rescue missions. They shall only operate in uncontrolled airspace and according to the limitations established in their Airworthiness Certificate, as emitted by AESA.

Nevertheless, even if Spain or other countries have their own regulations to control the usage of UAVs in their territories, it is still important to have an international and stable legislation to allow the sector to grow to its full potential.

## 1.4 Motivation

Traditionally, the most important payload that could be carried in an aircraft was human beings, that would perform their mission while aloft. Nevertheless, the advancements on sensing technology and wireless communications have forced a change on traditional aviation. Apart from commercial aviation, where the final objective is to transport people from one place to

---

<sup>2</sup>RPAS are considered as a subset of the UAV group. Fully automatic vehicles do not belong to the RPAS category, since the existence of a remote pilot is required at any time

another, in almost any other mission the role of the human workforce is to pilot the aircraft and/or operate the payload systems. This secondary role of the human operators implies that, given the maturity of the involved technology, they could be substituted by intelligent computer systems or, at least, disembarked from the aircraft into a safer Ground Control Station (GCS). The process of “unmanning” the aircraft also brings the advantages of decreasing the weight of the aircraft and thus improving its endurance and manoeuvrability, avoids putting the pilot in a dangerous situation, and helps alleviate the errors associated with tedious and repetitive tasks, among others.

However, there are also some downsides. In the technical department, there are still some issues regarding the electromagnetic spectrum allocation for the data-link with the vehicle [18], as well as accommodating unmanned aircraft within the Airspace System [7]. In addition, the most accused issues for experienced pilots are those related with the loss of situational awareness that comes as a result of eliminating the physical cues (body inertia, vibrations, noise. . . ) and relying on instrumental readings only [11]. Hence, some enhanced systems need to be integrated into the vehicle to overcome these limitations, providing the pilots with additional information for the safe execution of the mission.

Finally, for this project, the goal is to provide a system that reduces the risk of the widest range of UAVs from crashing with nearby obstacles, so that regular operations are carried with a higher level of safety. Eventually, the authorities could consider the increase in overall safety as a standard, triggering the modification of existing regulations to a more permissive set, and allowing the industry to take advantage of all the benefits that the incorporation of UAVs could bring to their activities.

## 1.5 Project objectives

According to the motivation as stated in Section 1.4, the final goal of this project is to develop a working prototype for proof of concept of a system able to detect and avoid obstacles that threaten the integrity of the UAV. Towards that end, some more specific objectives can be defined as follows:

- Identify the requirements needed for the Obstacle Collision Avoidance System (OCAS) to correctly fulfill its purpose
- Define the functional architecture of the OCAS
- Define the interfaces (communication channels and protocols) to be used by the OCAS for its correct integration on the UAV.
- Define the interaction channels and procedures between the operator and the UAV equipped with the Obstacle Collision Avoidance System.

- Develop a first working prototype as proof of concept of the Obstacle Collision Avoidance System (both hardware and software) and integrate it on a real UAV.

Additionally, the architecture of the solution should be designed with modularity in mind, permitting easy adaptation of the algorithms for later research activities.

## 1.6 Methodology

As it can be noticed, the objectives defined in Section 1.5 remember of the initial steps that are usually taken in the Systems Engineering approach for interdisciplinary design [21]. That approach will be adapted to the project, and some useful tools and concepts will be used from the NASA Systems Engineering Handbook [1], such as the requirements capture, the Functional Flow Block Diagram (FFBD), the Functional Architecture definition or the product integration via interfaces definition.

Finally the prototype created from the process will be tested in a series of common situations to prove that the product is capable of completing its task. Also, it will be demonstrated how the OCAS has been designed with flexibility and modularity in mind, explaining the possibilities to expand its features and proposing some ideas for future work.

## 1.7 Time planning

For any big project with defined deadlines, time management is of utmost importance. The elaboration of the thesis has been carried out during more than 10 months, and the different work phases have been monitored with a project management software tool. The resulting Gantt Diagram can be consulted on Figure 1.2.

## 1.8 Budget

This section describes all costs associated to the project and proposes an estimate of the budget needed to replicate it. The final cost results on **9521.48 €**, which is divided as follows.

### 1.8.1 Personnel expenses

The base annual engineering salary for an Engineering Degree holder in Spain is, according to the Spanish “XVI Convenio colectivo nacional de empresas de ingeniería y oficinas de estudios técnicos” [15], of at least 17,038.62 € per year, with a maximum of 1800 working hours. Thus, the minimum salary can be calculated as  $17038.62 \text{ €} / 1800 \text{ h} = 9.47 \text{ €/h}$ . With an estimated working time of approximately 880 hours, the calculated personnel expenses are 8333.60 €.



Figure 1.2: Gantt Diagram of the Project

### 1.8.2 Software cost

Most of the work has been performed on open-source software systems, such as Arduino / Ardupilot and Raspberry Pi / Linux. However, the calibration and initial programming and testing, prior to the payload deployment, was done on a laptop machine running Windows 10 Pro, listed at 279 € per license on the Microsoft Store.

### 1.8.3 Hardware cost

For the hardware part of the project, the aforementioned laptop will be considered together with all the components needed to build the test platform.

The PC was bought for 500 €. Assuming a linear depreciation period of 4 years, and that the dedication to the project equals the amount of total labour hours, the resultant expense is estimated as 12.58 €.

As one might expect, the prototype is composed of numerous individual components acquired to different sources. In Table 1.1, an estimation of their cost is done according to current prices on relevant stores. Notice that the F450 kit already includes most of the components needed for the UAV to fly (motors, controller board, frame. . .) as covered by M. Arteta in [17].

Component	Unitary Price	Units	Total
F450 kit	399 €	1	399 €
Propeller blades	2 €	4	8 €
Radio transmitter / receiver	51 €	1	51 €
Telemetry radio	48 €	1	48 €
Primary battery	40.85 €	5	204.25 €
Secondary battery	14 €	1	14 €
Raspberry Pi	33.81 €	1	33.81 €
Wireless WiFi adapter	19.95 €	1	19.95 €
Ultrasonic range finder	4.50 €	8	36 €
Resistor	0.05 €	30	1.50 €
Connection wires	0.10 €	50	5 €
Camera	24 €	2	48 €
Optical flow sensor	36 €	1	36 €
<b>TOTAL</b>			<b>904.51 €</b>

Table 1.1: Prototype hardware costs





## STATE OF THE ART

The relatively recent history of “small” (considered as weighting less than 25 kg) commercial UAVs implies that the technologies involved have not reached a high Technology Readiness Level (TRL) [26] until very recently, or are still under development (TRL 6-7). For that reason, most of the work considered in the present chapter is not yet ready for the market and has a great capacity to improve. Universities are actively exploring the autonomous aptitudes of UAVs, but the economical exploitation potential is still small due to the low reliability issues that these systems are encountering in non-controlled environments.

In the present chapter, some elements that might be of interest through the development of the project will be mentioned, together with their most characteristic features. Hence, the objective of this chapter is to provide some background information on which to later base the decisions that are to be made during the design phase, rather than exploring all the ongoing research on the diverse and very active field of UAVs.

## 2.1 Environment sensing

Knowing the environment is the initial step towards any interaction of a system with its surroundings. That knowledge could in principle be acquired a-priori and then copied into the system, but when either time-changing or completely unknown scenarios are considered, having a means of sensing the environment is essential.

### 2.1.1 Radar

Radar stands for RAdio Detection And Ranging. Its usage dates back to 1904, when Hülsmeyer registered the patent for his Telemobiloscope [19], using a primitive variant of the radar for

detecting metallic ships.

Nowadays, the radar works by emitting one powerful radio signal impulse against the object that needs to be located. If the signal reaches a solid object on its path, the electromagnetic wave will be distorted and part of it will be reflected back to the emission point, where a second listening antenna can detect it.

The distance of the detected object is calculated by measuring the flight time of the signal since it was emitted until it is detected, applying the signal propagation speed ( $3 \times 10^8$  m/s for electromagnetic waves) as correction factor. The azimuth position of the object can be estimated if the initial signal was created by a highly directional antenna, since the orientation of the transmitting antenna can be measured, and the sensed object must be contained within the electromagnetic radiation field.

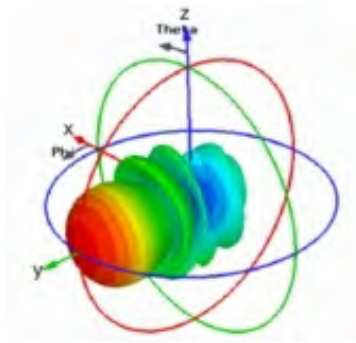

Figure 2.1: Highly directional radiation pattern. Source: cisco.com

The fact that radar uses electromagnetic waves implies that the response time can be very low, although some technical issues may arise for the same fact at the time of processing the returned signal. For that reason, radar-based sensor systems focus on temporal processing techniques to improve the results of the measurements [23].

### 2.1.2 Sonar

The ultrasonic rangefinder (commonly known as sonar, for SOund Navigation And Ranging) relies, like the radar, on the measurement of the flight time of a signal rebounding against the target. However, instead of being electromagnetic waves, the carriers are sound waves, with a frequency usually beyond the human hearing range upper threshold (hence ultrasonic).

It is important to mention that the calculation of distance from the flight time of the rebounded signal is to some degree dependent on the environment: The speed of propagation of sound depends on the temperature of the medium through which it propagates as  $a = \sqrt{\gamma R_g T}$ . Thus, the temperature of the air should be monitored to compensate for variations during the flight. Fortunately, the error associated with temperature changes around room temperature is of the same order than the accuracy of the sensor itself, so it is safe to consider ambient temperature at the initial calibration stage only and assume it stays constant thereafter.

### 2.1.3 Lidar

Light Detection and Ranging also works by measuring the time of flight of a signal. In this case, it is a visible light pulse, usually produced by a laser for its high coherence and low dispersion.

This system is convenient for ranging objects that are small or at a long distance from the sensor, but the small measuring point of the laser beam has some limitations when the mapping of a large area is required. In these situations, multiple measurements are usually performed sequentially with a rotation of the laser emitter between pulses, but the procedure significantly increases the latency of the system for obstacle detection, and also the complexity of the sensor system itself.

In summary, lidar is a good alternative for ranging, but not so much for detection.

### 2.1.4 Computer vision

The usage of regular cameras for physical environment sensing is certainly different than the previously considered, since it is not the flight time of a pulsed signal what encodes the information. Instead, one or more cameras provide a two-dimensional array of data each that can be processed to extract information of distance and location, among others, of any object that is within frame.

It is in that processing where both the advantages and draw backs of computer vision lie. On one hand, many different transformations can be applied to the stream of data from the cameras, and information can be extracted on very diverse aspects such as colour, luminosity, movement, position, texture. . . [9] Additionally, advanced processing techniques and even artificial intelligence can be applied to the image, which is a very flexible source of information. On the other hand though, the aforementioned processing tasks should be computed on a relatively high rate video stream, which implies several transformations on various video streams (for stereoscopic vision) with a few million pixels per image, at several frames per second. Furthermore, if obstacle detection and ranging needs to be performed, more than one viewpoint (and hence more than one camera) are required, and the matching problem (Figure 2.2) of the objects seen by the two and the geometric transformations are also quite demanding computational problems. Such a workload can only be dealt with by higher-end computer graphics cards nowadays at a reasonable rate for the effective control of a moving vehicle.

## 2.2 Collision avoidance

The conventional sense and control problem has two very defined parts: the data acquisition stage that has been studied in Section 2.1 and the actuation of the control variables to modify the state of the system. In this section, the application alternatives of the latter in TRL 9 (Actual system proven through successful mission operations [26]) products will be studied.

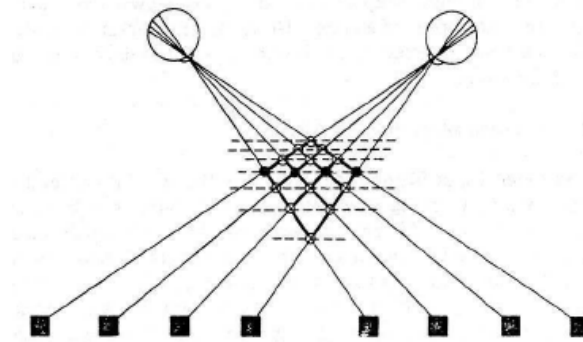

Figure 2.2: The stereo matching problem Source: [9]

### 2.2.1 TCAS on conventional aircraft

The Traffic alert and Collision Avoidance System is the standard system mandated for use by commercial aircraft. It creates a virtual safety volume around the aircraft, which is based on the time to the Closest Point Approach (CPA) [28].

For the system to work, the host aircraft and the threatening aircraft must both equip an ATC transponder. If the external aircraft has only a Mode A transponder, only Traffic Advisories (TA) can be issued by the TCAS; when it is Mode C or S, also Resolution Advisories (RA) are issued; if the external aircraft is also equipped with a TCAS II, vertical coordination between the two aircraft is additionally provided by means of an ask-answer procedure.

The system relies on two antennas that are usually placed at the top and bottom of the fuselage to provide antenna diversity. The signal carriers are 1030 MHz radio waves for the asking signal and 1090 MHz for the replying ones.

Regarding the actuation component of the system, it is fully manual. When a TA or RA are issued, the pilots are responsible to take the control of the aircraft and perform the recommended manoeuvre. Thus, the system itself cannot be considered to be the one avoiding the collision, but rather helping the higher-level aircraft + crew system accomplish it.

### 2.2.2 DJI Phantom 4

An Obstacle Collision Avoidance System was not available for commercial UAVs until as recent as March 2016. Chinese manufacturer DJI unveiled their Phantom 4 emphasising its “aerial camera” role for video professionals.

Their reason for including such a system is to facilitate the creative process of filming while the UAV manages the flying aspect of the mission as autonomously as possible. To that end, apart from the primary recording camera, the Phantom 4 also incorporates two smaller front-facing cameras that use stereoscopic vision algorithms to detect potential obstacles in the planned trajectory and modify it on-the-fly. In addition, it also incorporates a lower-level failsafe: when the vehicle is not able to compute a reasonable alternative trajectory before the obstacle enters

within a predefined distance to the vehicle as measured by the stereoscopic cameras, the flight controller will command a full stop to stationary flight until the obstacle is manually cleared by the pilot.



Figure 2.3: DJI Phantom 4 with stereo camera OCAS



## A BRIEF INTRODUCTION TO ARDUPILOT

As it was mentioned in Section 1.4, it is intended to bring the technology developed within this project to the widest range of UAVs. However, there exist in the market several families of controller boards (which mainly consist on a microcontroller or microprocessor, in charge of all the basic functions required for an stable flight) that can only be used with specific hardware and/or software, not being compatible with each other since they implement different communication protocols. Furthermore, some manufacturers work with proprietary software, of which little information on the low-level functioning is available to the public.

It is clearly impractical to try to target all the existing standards for this project, so a compromise needs to be made. The thesis will be elaborated for the Ardupilot family of controllers, for being the most widespread open-source<sup>1</sup> alternative. Some of the leading companies [22] in the sector actively support the Dronecode Project, of which Ardupilot is part, such as Intel, Qualcomm, Parrot, 3DR, Yuneec, AUAV, Walkera... [13]

It is important nonetheless to clarify some concepts and features of any Ardupilot-equipped UAV. More information can be found at [www.ardupilot.org](http://www.ardupilot.org).

### 3.1 Basic features

The most basic but important feature of the controller is to give control to the pilot over the vehicle. There are several components that make this function possible.

Firstly, the pilot expresses the desired movements of the vehicle through a Radio Control (RC) transmitter, shown in Figure 3.1a. The signal at 2.4 GHz is received by the RC receiver located in the vehicle, depicted in Figure 3.1b. Then the receiver translates the electromagnetic wave into

---

<sup>1</sup>The software is being developed at GitHub: <https://github.com/ArduPilot/ardupilot>

several PWM (Pulse Width Modulation) signals, one for each input channel up to a maximum of 8 channels, which are inputted to the controller board. However, for the primary control of the vehicle, only 4 channels are needed: throttle, roll, pitch and yaw. The additional channels are used to control extra features such as the flight mode, the landing gear or the camera controls.

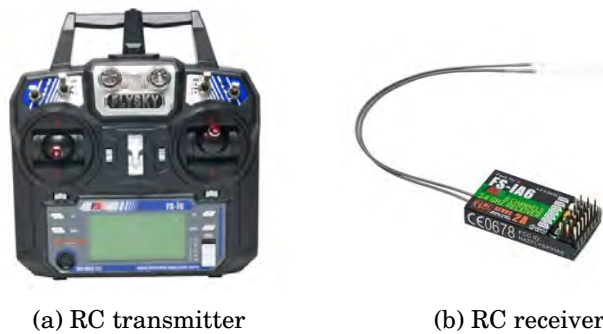

Figure 3.1: FlySky FS-i6 Remote Control ([www.flyskyrc.com](http://www.flyskyrc.com))

The second step is to translate the commands from the pilot into signals to the control elements of the vehicle. These can vary depending on the type of vehicle (for example the yaw command affects the rudder in the case of a fixed-wing aircraft, the tail rotor collective control for a conventional helicopter or the differential throttle in the diagonals for a multicopter) but the underlying processes are similar.

Every Ardupilot controller board must have at least an Inertial Measurement Unit (IMU) consisting of a 3-axis accelerometer plus a 3-axis gyroscope for the state determination of the vehicle. Additionally, a barometer, a GPS and other sensors can be integrated. Hence, reading the pilot's commands from the RC receiver and the state of the vehicle from the IMU, the output to the control elements can be computed by some regular PID control loops (more information on the topic can be found in [24]). To the output pins of the controller board are connected the control elements, be it some servo-motors for the control surfaces of a fixed-wing aircraft or brushless motors with propellers for the case of a multicopter. These elements are externally powered by the primary battery.

## 3.2 Ardupilot as part of a UAS

If Ardupilot wants to be used as a professional tool to enhance production or reduce costs, it can not rely on manual control only. For more advanced missions and proper calibration of vehicles with diverse configurations and physical properties, it is necessary to tweak the parameters that the control loops necessitate for their real-time computations. It is in those cases when a Ground Control Station can become useful. By connecting the vehicle to an external computer, the operator is no longer limited to the 8 input channels that the RC transmitter can provide.



Instead, the limit on the amount of information that the Ardupilot board can broadcast or absorb is only bound by the communication protocol that is implemented between the two.

For the Ardupilot ecosystem the protocol used is also open-source and receives the name of MAVlink<sup>2</sup> (MAV stands for Micro Aerial Vehicle). Its open nature allows developers to create a very diverse set of software and applications to communicate with the UAV, from the widespread Mission Planner and APM planner, to versions that run on Android devices for on-the-field operation or developer-oriented libraries that run under Python, for example.

Another feature that is worth mentioning is the lightweight nature of the protocol, which not only permits the connection via USB cable, but also wirelessly through what is usually called a telemetry radio, which effectively is a serial transmission of data over a 433 MHz radio wave carrier.

An experienced operator can take advantage of all the mentioned features to receive real-time information on the state of the vehicle while it is on the air, and also to send high-level commands to the vehicle. Those options will be further discussed in Section 3.3.



Figure 3.2: Screenshot of Mission Planner GCS, implementing the MAVlink protocol

<sup>2</sup>More information on the protocol can be found on [qgroundcontrol.org/mavlink/start](http://qgroundcontrol.org/mavlink/start). The message definitions and generator code can be found at its GitHub repository [github.com/mavlink/mavlink/](https://github.com/mavlink/mavlink/)

### 3.3 Advanced features

For an Ardupilot UAV to be able to automate some missions and procedures there are some additional requirements. Firstly, the IMU is appropriate for the evaluation of the vehicle's state variables, but the knowledge of its environment can only be acquired through absolute positioning sensors. Those sensors are usually a GPS module for horizontal positioning and a barometer for altitude measurement. Secondly, a wireless data-link provides a much more flexible way of interacting with the UAV during the execution of the mission.

#### 3.3.1 Flight modes

Ardupilot has separated the mentioned advanced features in different flight modes, which can be activated with the 5<sup>th</sup> channel on the RC transmitter or from the GCS. At the time of writing, there are 15 different flight modes, but only the most relevant ones for the project will be described here. A summary of the most important features can be found in Table 3.1.

From this point onwards the concepts involving Ardupilot will be particularised for the quadcopter variant, since it is the type of aircraft that will be used for the prototype. Similar information can be found for the rest of supported vehicle configurations, shown in Figure 3.3.

**STABILIZE** The default mode for manual control. Uses only the IMU data to control the flight. The pitch and roll channels define the Euler angles (instead of the rotation rate of Acrobatic mode) so that when the controls are released to neutral position, the vehicle will level off automatically. The yaw channel does control the yaw rate of the UAV instead, while for the throttle channel Ardupilot will not compensate for wind or other disturbances.

**ALTITUDE HOLD** Very similar to the Stabilize mode. The only difference is on the throttle channel, which controls the ascension rate instead of raw power transmitted to the motors. When the throttle stick is centered, the vehicle will hold the current altitude using the information measured by the onboard barometer.

**LOITER** Incorporates the GPS data to the Altitude hold mode, making it possible for the UAV to compensate for wind and IMU drift. The pilot still has control on the vehicle similarly to Altitude hold but when the control sticks are released, the position will be kept within a 1 metre error (provided good quality GPS signal).

**AUTO** This mode allows to automate missions and procedures. With the help of a GCS application, such as the one shown in Figure 3.2, the operator can click on a map to define waypoints and actions (take off, land, point to a certain direction, etc. are within the options) and save a data file to the vehicle's internal storage. Later, when the mode is activated, the vehicle will follow the predefined route without the need of direct input from the pilot. The throttle, yaw, pitch and roll controls will be disregarded when Auto mode is active, but the pilot can change the active mode at any time from the RC transmitter.

**RTL (RETURN TO LAUNCH)** RTL mode is commonly used as a failsafe feature, when communication either with the pilot or the GCS is lost. It is a very specific version of the Auto mode that automatically starts the return to Home procedure, landing the vehicle exactly where it took off from. The Home location is defined as the point where the motors were initially armed (the arming procedure resembles the engine startup of a conventional aircraft: the motors will not spin unless the vehicle is armed)

**GUIDED** The only difference between the Auto and the Guided modes is that whereas in the Auto mode the mission needs to be completely defined and uploaded to the vehicle before it is executed, the Guided mode allows for on-the-fly control of the vehicle from the GCS, taking complete advantage of the MAVlink commands over the telemetry link. This characteristic makes it very flexible for real-time development of applications.

Mode	Sensors used	Throttle	Roll/Pitch	Features
Stabilize	IMU	Power	Euler angles	Fully manual
Altitude hold	IMU + Barometer	Ascension rate	Euler angles	Enhanced altitude control
Loiter	IMU + Barometer + GPS	Ascension rate	Euler angles	Disturbance rejection
Auto	IMU + Barometer + GPS	No control	No control	Mission automation
RTL	IMU + Barometer + GPS	No control	No control	Failsafe
Guided	IMU + Barometer + GPS	No control	No control	Real-time commands

Table 3.1: Summary of the relevant flight modes

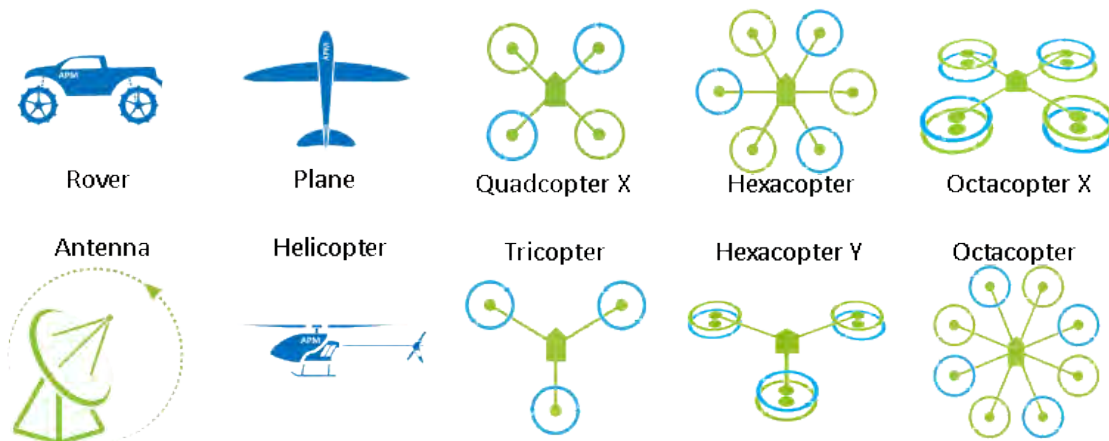

Figure 3.3: Vehicle configurations supported by Ardupilot



## PROBLEM STATEMENT

The objectives of the project have already been stated in Section 1.5. Following those ideas, the problem that is to be answered in this thesis can be stated with the following question:

*Is it possible to improve the operational safety of a wide range of UAVs by developing an intermediate functional layer that prevents physical collisions between the UAV and its surroundings?*

The above statement tries to condense the main idea of the thesis in a compact and precise manner. Nonetheless, some concepts within it might need some clarification:

**Operational safety:** A reliable collision avoidance system reduces the workload of the pilot so that higher-level tasks directly related to the operation of the mission can be performed more efficiently and safely.

**Wide range of UAVs:** As stated in Chapter 3 the project will focus on the widely-spread Ardupilot firmware, which is currently the leading alternative of open-source UAV controller software available.

**Intermediate functional layer:** The proposed solution shall be easily integrable within existing UAVs; offered as an enhancement to the toolbox of functions of the system. Thus, the solution shall incorporate additional features to the UAS, while the functions provided by Ardupilot should remain unaffected.

The problems is believed to be worthwhile answering since, as it was proven in the State of the Art study (Chapter 2), the technology is not mature and has not been implemented except on very specific products like the DJI Phantom 4.

Furthermore, a fully operable and reliable OCAS would allow for a more autonomous operation of the UAV, avoiding the pilot from needing to be focused on the immediate surroundings of the vehicle, thus permitting for an improved situational awareness and leading to a better overall execution of the mission. Ultimately, a higher safety level of general UAV operations could lead the authorities to reconsider the possibility of them flying for civil purposes with less restrictions, thus enabling companies to save vast amounts of money and manpower on the execution of activities that are currently being accomplished in a less effective way by human workers.

## SYSTEM DESIGN

As mentioned in Section 1.6, the design of the Obstacle Collision Avoidance System will follow the Systems Engineering approach. The main reason is that Systems Engineering provides some methods that prevent the errors with the highest consequences when the system to be designed is complex. As explained by Rolls-Royce Global Chief of Systems Engineering [10]:

*Systems Engineering collects and organises all the information needed to understand the whole problem, explores it from all angles, and then finds the most appropriate system solution.*

Furthermore, a key study published through INCOSE [29] looked at the phase of detection of errors, and the consequent cost of fixing them. Cost modelling was validated against a cross-industry range of defence and aerospace projects. Figure 5.1 shows the results of the study.

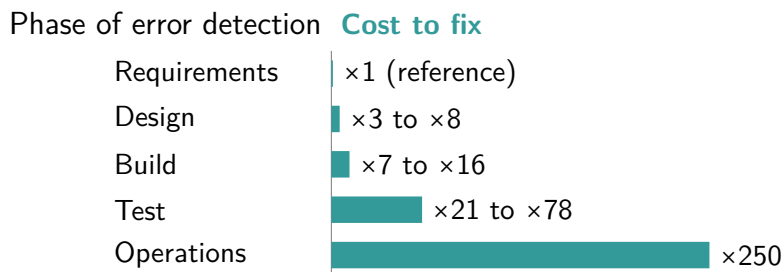

Figure 5.1: Cost to fix a design error. Source: [29]

Hence, in the present chapter, some of the most relevant Systems Engineering tools from the NASA Systems Engineering Handbook [1] will be applied.

## 5.1 Requirements capture

The design process for a system is requirement driven, since the requirements are what will define the cost, design, schedule. . . A requirement is a statement about or a characteristic of something that is needed.

Requirements can be derived from a variety of sources, like customer needs, stakeholders, regulations, procedures, constrains, etc. However, for this project, customers and stakeholders will be disregarded (since none exist) and the motivation and problem statement as described in Section 1.4 and Chapter 4, respectively, will be used instead.

In the present section some requirements will be posed, but only those that directly apply to the OCAS subsystem or its interfaces, since the platform is considered to be completely functional prior to the introduction of the solution (following the modularity concept).

Req. ID	Requirement	Traceability (sourced from)	Traceability (allocated to)
Certification			
1.1	The UAV shall meet European regulations	EC No 218/2008	All
1.2	The UAV shall meet Spanish regulations	Ley 18/2014	All
Architecture			
2.1	The OCAS shall work independently of the UAV	Motivation	Power, communications
2.2	The OCAS shall be self-contained within the UAV	Integration	Power
Functionality			
3.1	The OCAS shall detect obstacles surrounding the UAV	Motivation	Sensors
3.2	The OCAS shall avoid collisions with the detected obstacles	Motivation	Processing, actuation
3.3	The OCAS shall take control of the UAV in case of danger	Req. 3.2	Actuation
3.4	The OCAS shall not interfere with existing Ardupilot functions	Motivation	Communications
3.5	The UAV shall maintain a communications data-link with the GCS at all time	Safety / FFBD	Communications
Performance			
4.1	The OCAS shall detect obstacles within the stop region of the UAV	Technical constraint	Sensors
4.2	The OCAS shall detect all obstacles of threatening size	Technical constraint	Sensors
4.3	The OCAS shall be powered along the full mission	Safety / FFBD	Power



## 5.1. REQUIREMENTS CAPTURE

Interfaces			
5.1	The OCAS shall know the state of the UAV	FFBD	Communications
5.2	The OCAS shall send commands to the UAV	FFBD	Communications
5.3	The OCAS shall be accessible from the GCS	Human factors	Communications
5.4	The OCAS shall be activated and deactivated by the pilot	Safety / Human factors	Communications
Safety			
6.1	The OCAS shall improve the operational safety of the UAV	Motivation	Processing, actuation
6.2	The operation of the OCAS shall not be disrupting to the workflow of the pilot	Motivation	Communications
Reliability			
7.1	The OCAS shall avoid any physical collision	Motivation	Actuation
7.2	The OCAS shall be operative regardless of the state of the controller board	Safety	Power, processing
Ergonomics and human factors			
8.1	The OCAS shall be operable after a short training by any pilot	Motivation	Communications
8.2	The OCAS should be engaged and disengaged at discretion of the pilot	Safety / FFBD	Communications
Loads			
9.1	The OCAS shall stand the same loads as the UAV	Integration	Structure
Weight			
10.1	The UAV + OCAS shall not weight more than the limit of the UAV segment	Regulations	Hardware
Environment			
11.1	The OCAS shall withstand the effect of open-air flight	Integration	Hardware

Table 5.1: OCAS System-level Requirements

Notice that Table 5.1 is not static, and should be updated during the design process, since some of the tools of Systems Engineering are designed to expose missing requirements. Thus, some requirements have been written at later design stages, as the “Traceability (sourced from)” column shows. Also, the fourth column is to be completed in the subsystem design stage, when the system requirements will be allocated to one or more specific subsystems or components.

## 5.2 Logical Decomposition

The Logical Decomposition is an intermediate step between the Requirements Capture and the Design phases. Its purpose is to understand the manner in which the requirements affect the way that the system functions, for the requirements loop; and to identify a feasible solution that functions in a way that meets the requirements, for the design loop, as shown in Figure 5.2

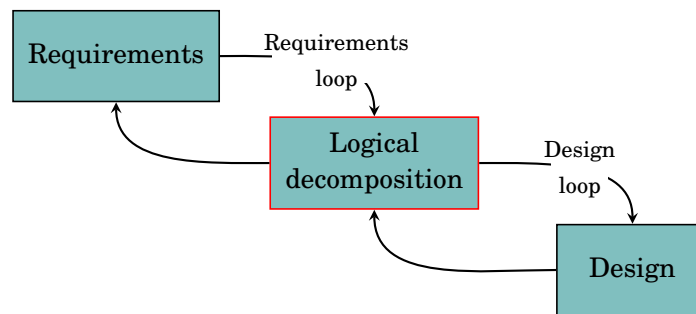

Figure 5.2: The Logical Decomposition phase

### 5.2.1 Functional Architecture

The logical decomposition performed during the functional analysis decomposes the top level requirements and allocates them down to the lowest desired levels. The main outcome of the process is the Functional Architecture (Figure 5.3), which helps establish relationships between requirements, and ultimately build a System Architecture.

The main purpose is to create an association between the requirements and the functions that the system needs to be able to perform in order to meet them. In the process, any discrepancy or missing items can (and should) be identified and corrected in an iterative manner.

### 5.2.2 Functional Flow Block Diagram (FFBD)

Once the functions of the system are defined, it is useful to dispose them so that the sequential use of each of them during the mission is shown. To that end, the Functional Flow Block Diagram is used. In the FFBD each function is represented by a block, and it is described in terms of inputs, outputs and interfaces. In the case that a function is composed of several sub-functions, those will be represented hierarchically from the top level down to the most specific sub-function, maintaining the general flow.

The FFBD shows *what* must happen, and provides an end-to-end path considering all the functionality of the system and the predefined use-case scenarios. Parallel or alternate paths might be considered.

For the block diagrams depicted in Figures 5.5 to 5.10, the symbology explained in Figure 5.4 is used.

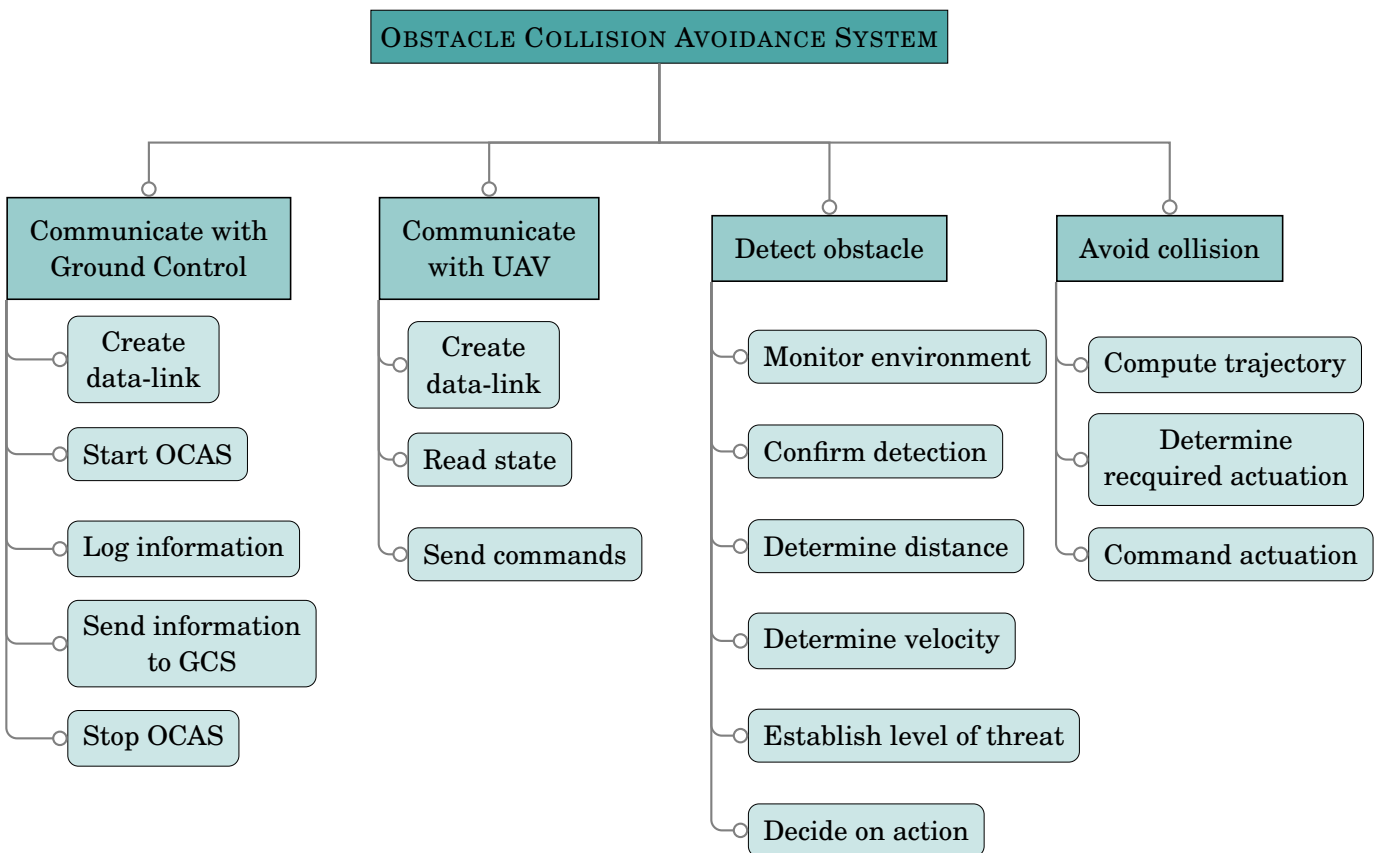

Figure 5.3: OCAS Functional Architecture

- Function
 Represents an individual function or subfunction as defined in the Functional Architecture from Figure 5.3.
  
- Logic
 Represents a logical *and* or *or* gate for defining parallel or alternative paths, respectively.
  
- Reference
 Represents a reference block that specifies the origin or destination of a path from an external function of the system.
  
- Boundary
 Represents the boundaries of the functional description, be it the whole system or a subfunction of it.
  
- Indicates the sequential order that is to be followed from one function to another.
  
- Indicates an information flow between two functional blocks.

Figure 5.4: Symbology used for the FFBDs

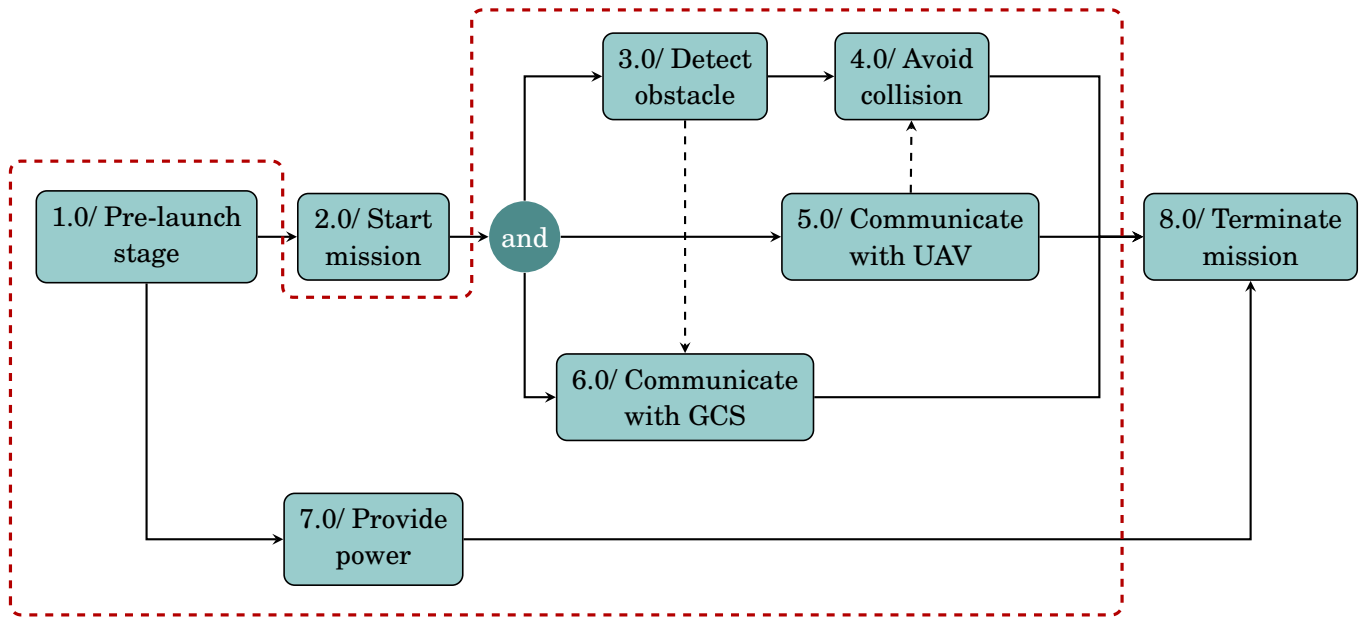

Figure 5.5: OCAS Functional Flow Block Diagram. TOP LEVEL

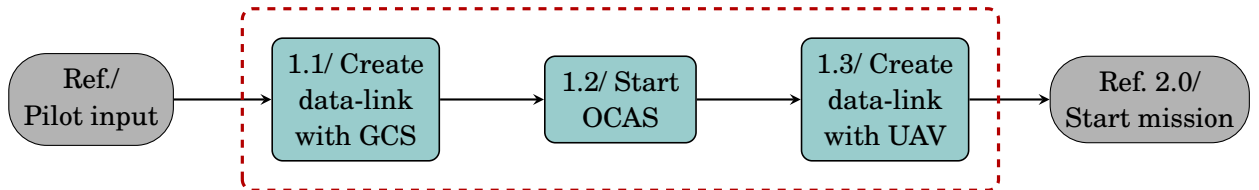

Figure 5.6: OCAS Functional Flow Block Diagram. 1<sup>st</sup> STAGE

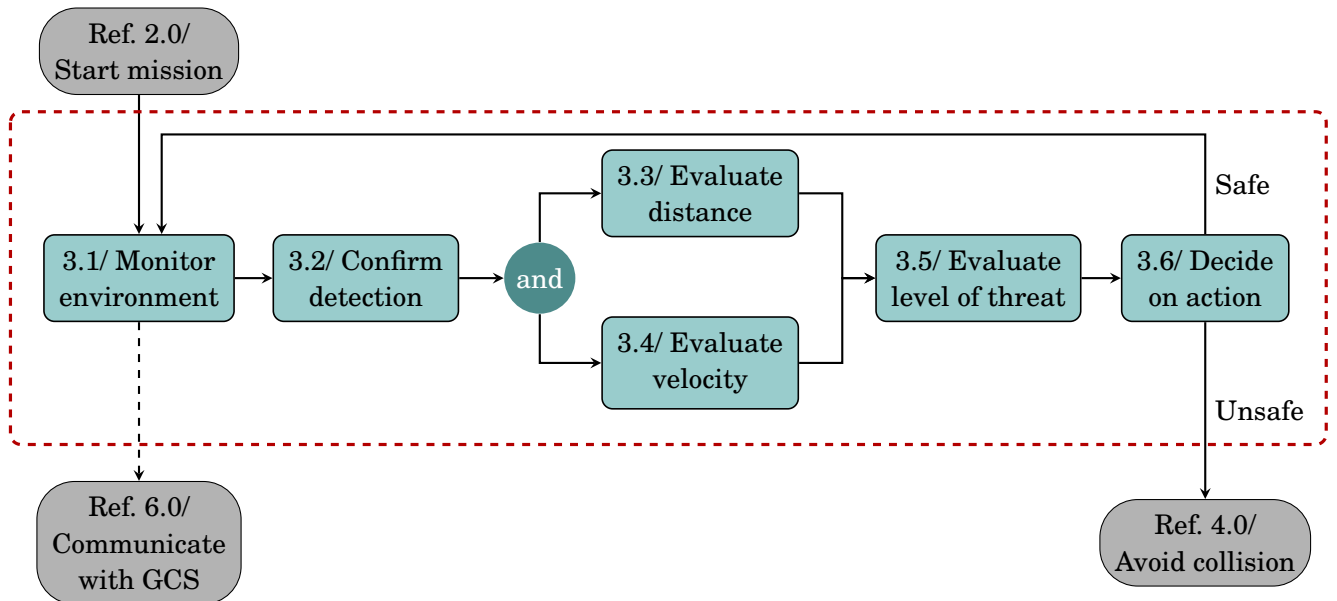

Figure 5.7: OCAS Functional Flow Block Diagram. 3<sup>rd</sup> STAGE

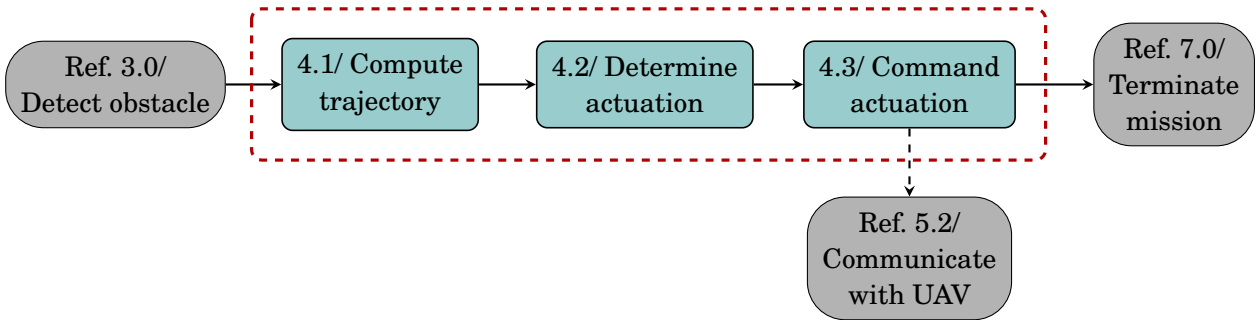

Figure 5.8: OCAS Functional Flow Block Diagram. 4<sup>th</sup> STAGE

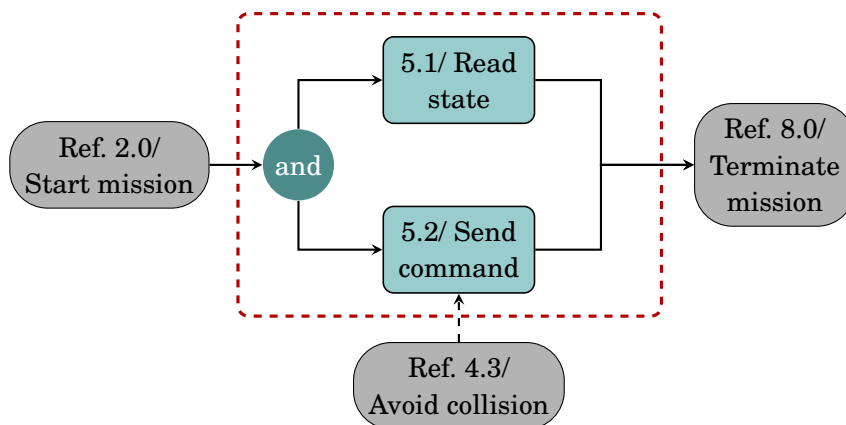

Figure 5.9: OCAS Functional Flow Block Diagram. 5<sup>th</sup> STAGE

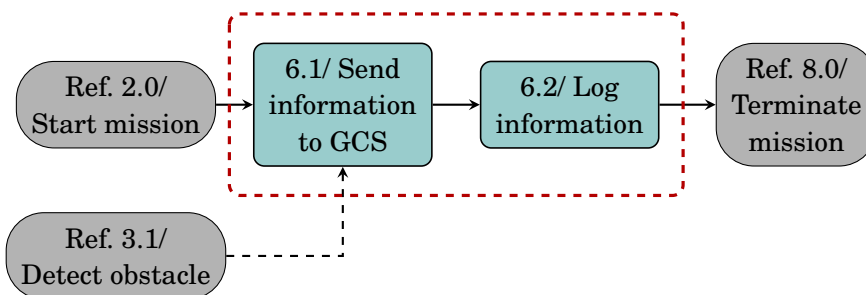

Figure 5.10: OCAS Functional Flow Block Diagram. 6<sup>th</sup> STAGE

### 5.2.3 Product Breakdown Structure (PBS)

Once the functions are properly defined, they need to be allocated to the subsystems that will be in charge of accomplishing them. To that end, the system is decomposed in its forming subsystems ensuring that all the functions can be achieved by the system. The decomposition process is visually shown via the Product Breakdown Structure, which is represented in Figure 5.11.

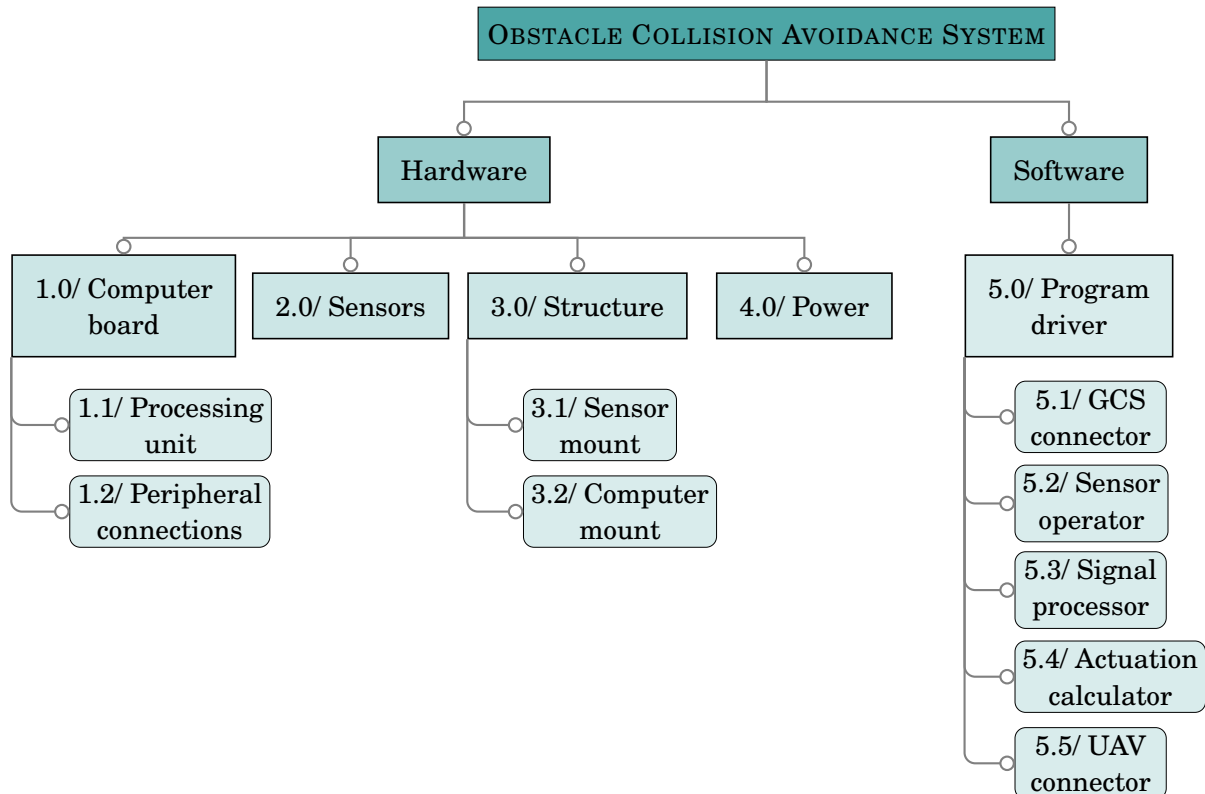

Figure 5.11: OCAS Product Breakdown Structure

### 5.2.4 Functional-Physical matrix

Finally, to couple the Requirements (Table 5.1) with the Functional Architecture (Figure 5.3) and with the Physical product (Figure 5.11), a functional-physical matrix can be built. This tool is very relevant since it exposes possible mismatches between the three steps, which would lead to requirements not being met or a product that cannot perform its intended functions. Thus, by filling the matrix, the designer can go back to previous steps and adjust anything that is needed in order to avoid the exponential increase in cost that was mentioned at the beginning of the present Chapter.

For the matrix represented in Table 5.2, the requirements, functions and subsystems have been represented by their ID as defined in Table 5.1, Figures 5.5 to 5.10 and Figure 5.11, respectively.

Req. ID	Funct. ID	Subsystem ID										
		Hardware						Software				
		1.1	1.2	2.0	3.1	3.2	4.0	5.1	5.2	5.3	5.4	5.5
1.1	All	*	*	*	*	*	*	*	*	*	*	*
1.2	All	*	*	*	*	*	*	*	*	*	*	*
2.1	All						*					
2.2	All				*	*	*					
3.1	3.0	*	*	*	*		*		*			
3.2	4.0	*	*				*			*	*	*
3.3	4.3	*	*				*		*	*	*	*
3.4	5.2	*	*								*	*
3.5	6.0	*	*				*	*				
4.1	3.1-3.4			*	*		*		*	*		
4.2	3.1-3.4			*	*		*		*	*		
4.3	7.0						*					
5.1	5.1	*	*				*					*
5.2	5.2	*	*				*					*
5.3	6.1	*	*				*	*				*
5.4	1.2	*	*				*	*				
6.1	4.0	*	*	*	*	*	*	*	*	*	*	*
6.2	6.0		*		*	*	*	*			*	
7.1	4.0	*	*								*	*
7.2	6.0	*	*				*	*	*			
8.1	1.0,6.0	*	*					*				
8.2	1.2		*					*				
9.1	Perf.	*	*	*	*	*	*					
10.1	Perf.	*	*	*	*	*	*					
11.1	Perf.	*	*	*	*	*	*					

Table 5.2: OCAS Functional-Physical matrix

As it can be seen for requirements 9.1, 10.1 and 11.1, they are requirements affecting the entire system, and thus cannot be associated to any function: they are requirements that impose hardware constraints only.

### 5.2.5 Interfaces definition ( $N^2$ diagram)

For the correct integration of the system the definition of its interfaces is of utmost importance. The  $N^2$  diagram is commonly used for the development of those interfaces [16].

In the  $N^2$  diagram, an  $N \times N$  matrix is built. In the main diagonal all the systems or subsystems are placed, while the upper and lower triangles are reserved for the interfaces, which are classified into inputs and outputs. An input to any of the modules is represented through its vertical cells, while the output is placed on the horizontal rows. An example  $N^2$  diagram can be found in Figure 5.12.

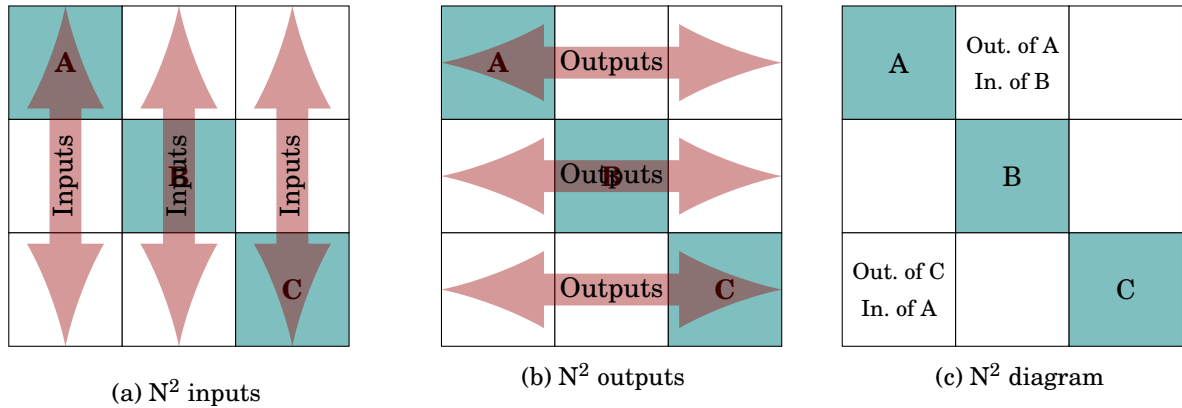

Figure 5.12: Example of a  $N^2$  diagram

For the Obstacle Collision Avoidance System  $N^2$  diagram in Figure 5.13, the subsystems defined in the Product Breakdown Structure (Figure 5.11) will be placed in the main diagonal.

In this Figure, the grey blocks represent external systems to the OCAS, while the blue ones are subsystems of the OCAS itself. In a regular UAV, with no OCAS implemented, the pilot would only be executing the outermost *green* loop: only in direct control with the UAV. Nonetheless, the OCAS provides an additional layer of safety that is functionally placed between the pilot and the UAV; but also adds another interface the pilot has to deal with: the GCS connector is the gate to the OCAS, which in turn connects via the Central Processing Unit to the rest of the system. Hence, the *green* interfaces designate the human links with both the OCAS and the UAV.

Further, the *yellow* interfaces have been highlighted since they represent the traditional sensing and control problem. Notice how the state of the UAV is transmitted from the UAV connector (that information is relayed by the UAV) and the sensors to the Processing Unit. From the hardware-software interface downwards, the information is processed, the actuation calculated and ultimately the command is sent to the UAV.

The *blue* interface has been created for information logging in response to Function 6.2 as defined in the FFBD. It could also serve as a debugging channel during the implementation phase.

Finally, the *black* interfaces on the hardware side shows how the system has been designed meeting requirements 2.1 and 2.2, which stated that the OCAS shall be independent of the UAV and self-contained. In this case, it has been decided that the OCAS would carry its own power source to provide energy to its components. However, the power is not transmitted down to the UAV, which could be more weight efficient but would significantly modify the architecture of the original UAV, disregarding one of the main requirements from the motivation of the project.



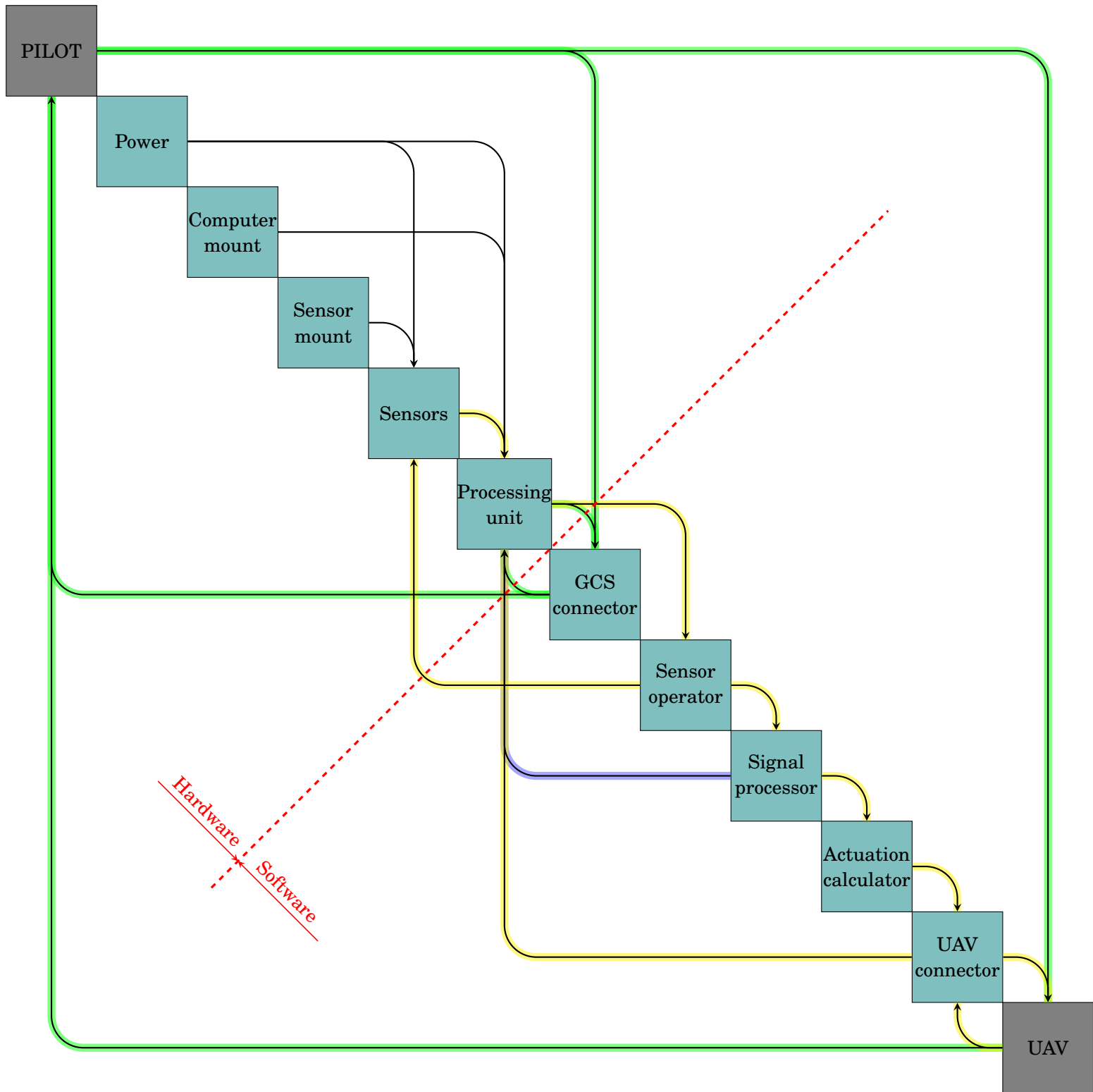

Figure 5.13: OCAS N<sup>2</sup> diagram for interfaces definition



## SYSTEM IMPLEMENTATION

The product realisation phase of the Systems Engineering approach will be presented in the current chapter instead of the previous one since the focus of this phase was put in the software part, for the hardware one (mainly structural mounts) being too dependant on the configuration of the existing UAV. Hence, all the design, implementation and testing of the software branch of the project were conducted in a parallel manner, as will be exposed in this part of the thesis. Nevertheless, the final hardware assembly of the system in the working prototype will also be discussed at the end of the present Chapter for completeness.

Chapter 6 will describe the complete implementation of the Obstacle Collision Avoidance System within the Unmanned Aerial System starting from the uppermost level and deepening through the execution of the interfaces and the software layers down to the custom-built control script.

### 6.1 The OCAS within the UAS

This section describes the architecture of the UAS prior to the implementation of the OCAS. Then, the uppermost integration level is explained, emphasising the compliance with Requirement 3.4 (lack of interference with the Ardupilot functions).

#### 6.1.1 Overview of the existing UAS

The regular Ardupilot-based Unmanned Aerial System with Ground Control Station capabilities is composed of three main subsystems:

Firstly, the UAV, which is considered to be fully operable. That is, the UAV concept encloses the airframe, propulsion, power source and all the other components as described in [17]; but

most importantly, the controller board with the Ardupilot software, considered as the brain of the UAV, which dictates how the vehicle will behave during operation.

Secondly, the pilot with the Radio Control transmitter (see Figure 3.1a) will also be considered a subsystem of the UAS. He/she has direct control of the UAV when flying in manual mode, plus is responsible of the operation of the GCS when the UAV is in Automatic or Guided modes (see Chapter 3).

Thirdly, the computer running the GCS software and having a real-time wireless connection with the UAV while in the air.

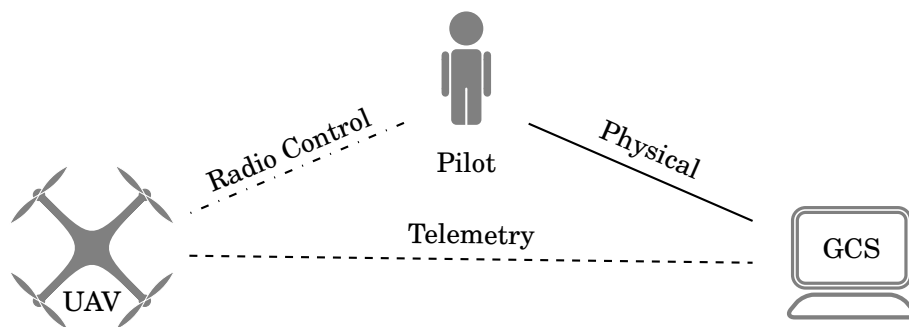

Figure 6.1: Regular Ardupilot UAS architecture

In addition, the interfaces between these subsystems are depicted in Figure 6.1 and work as follows:

The Radio Control (RC) link is established between the RC transmitter held by the pilot and the RC receiver that is directly connected to the controller board. A 2.4 GHz radio wave transmits information on the position of the control sticks as a PWM signal directly to the Ardupilot software, as explained in Section 3.1.

Likewise, the telemetry link consists of a 433 MHz duplex radio wave that carries MAVlink messages from the UAV to the GCS and viceversa, allowing for configuration, calibration and operation of the autonomous flight modes while the vehicle is aloft.

Finally, the pilot has direct physical access to the GCS computer.

### 6.1.2 Integration of the OCAS

The integration of the OCAS into the UAS shall preserve the basic Ardupilot functions. Thus, the architecture should not be significantly modified. The final decision on the UAS architecture after the integration of the OCAS is shown in Figure 6.2.

With this setup, the original connections and functions are maintained while the OCAS, which is mounted onboard the UAV, communicates with it through a USB cable via the MAVlink protocol (the same one used for the telemetry link). Additionally the GCS has a second wireless

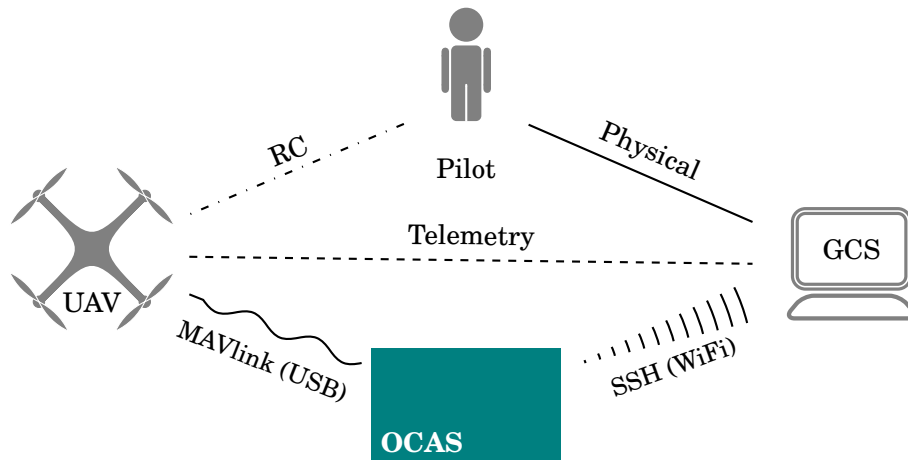

Figure 6.2: OCAS-equipped UAS architecture

link to the OCAS via WiFi, making use of the SSH (plus optional X Window System forwarding) protocol. More information on these interfaces is provided in Section 6.3.

## 6.2 Component choice

Only after properly defining the requirements, functions and architecture of the Obstacle Collision Avoidance System can the components be chosen to ensure that the system is correctly designed to meet specifications.

### 6.2.1 Sensors

The most relevant sensing alternatives were already exposed in Section 2.1. In this Section, the most appropriate one for the project will be chosen according to the specifications.

Certainly, all the options considered have their advantages and disadvantages. The purpose of the selection process is to evaluate all of those in a trade-off study which ensures that the final selection provides the best alternative to the system. The steps to a successful trade-off study are [25]:

1. Definition of the problem
2. Definition of the constraints
3. Generation of alternative solutions
4. Definition of the evaluation criteria
5. Definition of the weight factors

## 6. Fulfillment of the trade study

## 7. Ranking of the solutions

For the three first steps, those have already been done in Chapter 4, Section 5.1 and Section 2.1, respectively. For the rest of the steps, a tabular format will be used.

The evaluation criteria can be defined as the parameters considered important for the sensors to fulfill towards the correct achievement of their function, and will be presented on the first column of the table.

A weight factor will be given to each of the evaluation criteria according to their importance in the sensing and integration problems. Those will be normalised ensuring that the sum of all of them add up to unity, and will be presented in the second column of the table.

The trade study will then be fulfilled by rating each of the alternatives on the evaluation criteria as previously defined. The mark given, ranging from 0 to 1, represents the general capability of the alternative on the corresponding evaluation criteria.

Finally, the ranking of the solutions is performed by combining (multiplying) the weight factors with the ratings given to the alternatives on each of those criteria, to ultimately sum all of those and obtain a single figure for every alternative considered. The objectively most appropriate alternative is the one with highest rating after the trade-off study.

Criteria	Weight factor	Computer vision		Sonar		Lidar		Radar	
		Rating	Combined	R.	C.	R.	C.	R.	C.
Accuracy	0.1	0.4	0.04	0.8	0.08	1	0.1	0.6	0.06
Range	0.12	1	0.12	0.4	0.048	0.8	0.096	0.6	0.072
Ease of operation	0.12	0.6	0.072	1	0.12	0.6	0.072	0.4	0.048
Ease of integration	0.15	0.6	0.09	0.8	0.12	0.6	0.09	0.2	0.03
Ease of processing	0.12	0.2	0.024	1	0.12	0.8	0.096	0.6	0.072
Availability	0.12	0.8	0.096	0.8	0.096	0.6	0.072	0.6	0.072
Cost	0.1	0.6	0.06	1	0.1	0.2	0.02	0.8	0.08
Flexibility	0.05	1	0.05	0.4	0.02	0.4	0.02	0.6	0.03
Weight	0.12	1	0.12	0.8	0.096	0.4	0.048	0.8	0.096
<b>TOTAL</b>			<b>0.672</b>		<b>0.8</b>		<b>0.614</b>		<b>0.56</b>

Table 6.1: Sensor alternatives trade-off study

As it can be seen in Table 6.1, the most appropriate sensor to be used in the OCAS according to the performed trade-off study is the ultrasonic rangefinder. The reasons for that are mainly the high score obtained in the ease of operation, integration and processing, as will be seen during the implementation process, as well as its low cost; which were all considered to be important properties for the chosen sensor to meet for this project.

In particular, the chosen sonar for this project is the HC-SR04, shown in Figure 6.3.



Figure 6.3: Chosen ultrasonic rangefinder: HC-SR04. Source: [arduinolearning.com](http://arduinolearning.com)

### 6.2.2 Computer board

The choice of processing unit for the OCAS is not nearly as difficult as the sensor case. The main available alternatives are either a microcontroller board or a Single Board Computer (SBC), which differ in the type of CPU architecture.

A microcontroller board can be as simple as a single Atmel AVR microchip, although they generally incorporate additional features for easier programming and connection with other peripherals. The best example of microcontroller boards is the Arduino family. These board usually incorporate an 8-bit processing unit, which can be considered computationally underpowered according to present standards, and thus the programs are frequently coded in C/C++ languages due to their high resource efficiency. Also, these boards do not have any software feature out-of-the-box, which implies that every required function needs to be programmed from scratch on the chip.

On the other hand, an SBC can be thought of as a full Personal Computer, except in a reduced form-factor. These computers do not generally exceed the footprint of a credit card, albeit embodying all the necessary components such as RAM and non-volatile memory, USB ports and even the convenient General Purpose Input / Output (GPIO) pins for low-level hardware integration. Moreover, SBCs are driven by complete Operating Systems (OS), featuring convenient general kernel and communications tools. Additionally, these computers are able to run virtually any computer software available, which also means that applications can be programmed in a wide range of languages.

This brief analysis should be enough to prove that an SBC is more capable on almost any aspect than a microcontroller board and significantly more flexible. Thus, for this project, a Raspberry Pi 2 Model B SBC was selected for the reasons mentioned above and additionally because it is widely available and runs a full Debian Operating System. The only disadvantage is its higher power consumption as compared with the Arduino family of microcontrollers, which can nevertheless be neutralised by powering the OCAS with an off-the-shelf portable USB battery pack which outputs a continuous current of 5V, 2A: just enough to provide energy to the Raspberry Pi and all the peripherals.



Figure 6.4: Raspberry Pi 2 Model B. Source: [raspberrypi.org](http://raspberrypi.org)

### 6.2.3 Other components

Clearly, the most important components of the OCAS are its sensors and processing unit. The other elements are less critical and the selection process was less exhaustive. The component list considered for the prototype will only be listed here for completeness and to aid any interested researcher on the reproduction of the project.

**POWER SOURCE** As mentioned in the previous section, any portable USB battery pack with at least 5V, 2A continuous current will suffice to power the computer board and its peripherals. The one used for the project is the Amazon Basics 5600 mAh battery, which can potentially last more than two hours of operation with the OCAS.

**NETWORK ADAPTER** For the connection with the Ground Control Station, a wireless WiFi network will be used. Unfortunately, the Raspberry Pi does not include any wireless antenna, so the external TP-Link TL-WN822N has to be mounted on the testing platform, although any other similar model would be just as suitable.

**TESTING PLATFORM** The testing part of this project is based upon the Bachelor Thesis by M. Arteta [17], which provided an already calibrated and flight-capable F450 quadrotor UAV.



Figure 6.5: Testing platform, with OCAS already integrated

## 6.3 OCAS peripheral connections (hardware interfaces)

As already stated in Section 5.2.5, the main component of the OCAS is the computer board, which can be considered as a hub on which the rest of the components of the OCAS are brought together. Thus, the first step is to define the information pathways of the Raspberry Pi with the other hardware components.

The physical layout of the OCAS is shown in Figure 6.6. Notice that only Raspberry Pi peripherals are being considered. They are connected in the following manner:



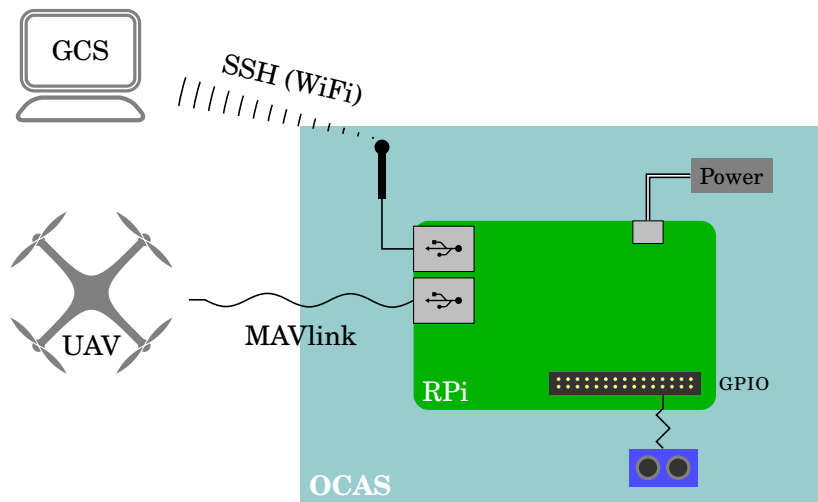

Figure 6.6: OCAS hardware layout

### 6.3.1 Power connection

For the Raspberry Pi to boot up, the only requirement is to provide a continuous current of 5V and enough current to power any other peripheral as well as the board, which in any case will not be higher than 2A. Thus, the battery pack, providing a continuous source of energy during the whole duration of the mission is enough to meet the requirement. It is connected to the Raspberry Pi SBC via a conventional USB type A, at the battery end, to micro-USB type B, at the computer end; no additional action being required.

### 6.3.2 MAVlink connection

The connection with the UAV (i.e. with the Ardupilot controller board) is done also via a regular USB cable, making use of the serial communications protocol. The serial protocol is a simple manner of transferring information which consists on transmitting the data one bit at a time, avoiding the synchronisation problem. Hence, the only issue is that both ends must agree in advance on the transmission rate. This is done by setting a common “baud rate”, where a baud is the unit for symbol change (signal event) rate, commonly measured in bits per second. In the particular case of communicating with the UAV, the messages transmitted through the serial link are defined according to the MAVlink protocol.

### 6.3.3 GCS connection

The link with the Ground Control Station is composed of two intermediate steps:

On one hand, the network adapter is connected to a USB port on the Raspberry Pi to provide the SBC with wireless networking capabilities. This connection is entirely handled by the kernel,

the drivers of the adapter itself and the operating system, and needs no further action from the integrator.

The second step is decidedly more complex. Firstly, the Raspberry Pi needs to be set up to wirelessly connect to the same network as the GCS computer. There are several ways to achieve this goal, but an uncomplicated one is to create an ad-hoc network from the GCS computer (running Windows) to which the Raspberry Pi is directly connected. The specific details are explained in Appendix A. This approach has been mainly chosen for its simplicity and portability, but notice that there exist more advanced network architectures that could provide significantly better performance. Secondly, the SSH connection needs to be established over the network. The process involves searching for the Raspberry Pi's address on the network, connecting to the SSH port and, optionally, setting up an X server for an easier Graphical User Interface (GUI) with the OCAS. More details on the steps to be taken are developed in Appendix B.

### 6.3.4 GPIO connection

The General Purpose Input / Output pins on the Raspberry Pi operate on a notably lower level than the previous hardware connections. As their name implies, the GPIO pins are the most general type of connection the Raspberry Pi can handle. The reason is that these pins have to be manually operated; that is, each of the pins can be set via software to either a HIGH or LOW state, meaning 3.3V or 0V with respect to the Ground (GND) potential, respectively.

In this project, the GPIO pins will be used to both trigger the ultrasonic rangefinders and read the returning signal that encodes the information on the distance from the sensor to the detected obstacle.

Besides, the sonar is equipped with its own microcontroller, which handles the lowest-level signals. For its operation, it counts with 4 different pins (see Figure 6.3):

1. GND, or Ground, specifies the reference voltage of the device.
2. VCC, which stands for Voltage Continuous Current, powers the sensor at 5V.
3. Trigger is an input signal pin. A HIGH value on this pin triggers (hence the name) a series of short bursts of sound from the piezoelectric speaker, which will rebound on any close obstacle.
4. Echo is the output signal pin. The sensor's microcontroller processes the sound captured by the microphone and sends a pulse through the echo pin which lasts exactly the same amount of time that the ultrasonic signal took to rebound on the obstacle and be received back at the sensor. Knowing the speed of propagation of sound (given by  $a = \sqrt{\gamma R_g T}$ ) and the time taken for the wave to travel to the obstacle and back, the distance can be calculated with  $d = a \cdot t/2$

The ultrasonic rangefinder’s technical documentation can be found in Appendix C.

On the Raspberry Pi side, the VCC pin shall be connected to any 5V pin, the GND pin to a Ground pin, and the Trigger and Echo pins to any numbered GPIO pins, depicted in Figure 6.7.

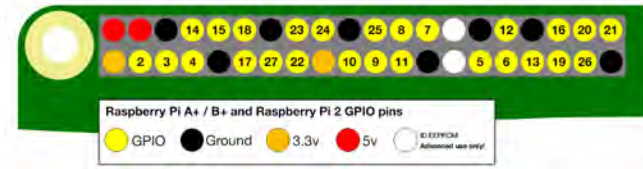

Figure 6.7: GPIO pins on the Raspberry Pi 2 model B Source: raspberrypi.org

There is one important issue that needs to be noticed, though. The rangefinders work on 5V only and, while the Raspberry Pi can provide 5V to power the sensors, the GPIO pins can be damaged if operated at more than 3.3V. Thus, the signal pins must be reduced from 5V to 3.3V before being connected to the SBC. The solution to the problem is to use a “voltage divider”, which is a passive circuit that outputs a fraction of the input voltage by means of a pair of resistors, which are connected as shown in Figure 6.8.

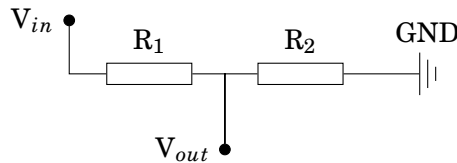

Figure 6.8: Schematic of a voltage divider

In the present case, for the voltage to drop from 5V to 3.3V, the resistors need to meet:

$$(6.1) \quad \frac{V_{in}}{R_1 + R_2} = \frac{V_{out}}{R_2} \Rightarrow \frac{V_{in}}{V_{out}} = \frac{R_1}{R_2} + 1 \Rightarrow \frac{R_1}{R_2} = \frac{5V}{3.3V} - 1 \Rightarrow \frac{R_1}{R_2} = \frac{1}{2}$$

So finally, an ultrasonic rangefinder connected to GPIO pins 14 and 15, for instance, would be connected as shown in Figure 6.9.

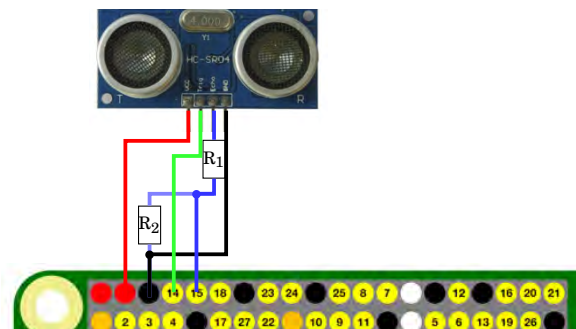

Figure 6.9: Connection of the HC-SR04 sensor to the Raspberry Pi

## 6.4 Software: Bringing everything together

Having several flows of information arriving to the Raspberry Pi, it is crucial to set up a system that acquires all the data before it can be processed. In the present section such a system will be described.

### 6.4.1 The Operating System

The first software layer on the Raspberry Pi (apart from the kernel) is the Operating System (OS). In this case, the Linux OS is Raspbian Wheezy, which is a version of Debian adapted to be run on the ARMv7 chip of the Raspberry Pi.

Raspbian is a complete OS, and as such its abilities are varied, being the most relevant for the project the network management tools and the capability of running external software applications. Within the OCAS, Raspbian will be used as container of the software subsystems specified in the Logical Decomposition phase of the design process (Figure 5.11), plus it will directly handle the functions associated to the GCS connector. An schematic of the relevant software architecture to the OCAS is represented in Figure 6.10.

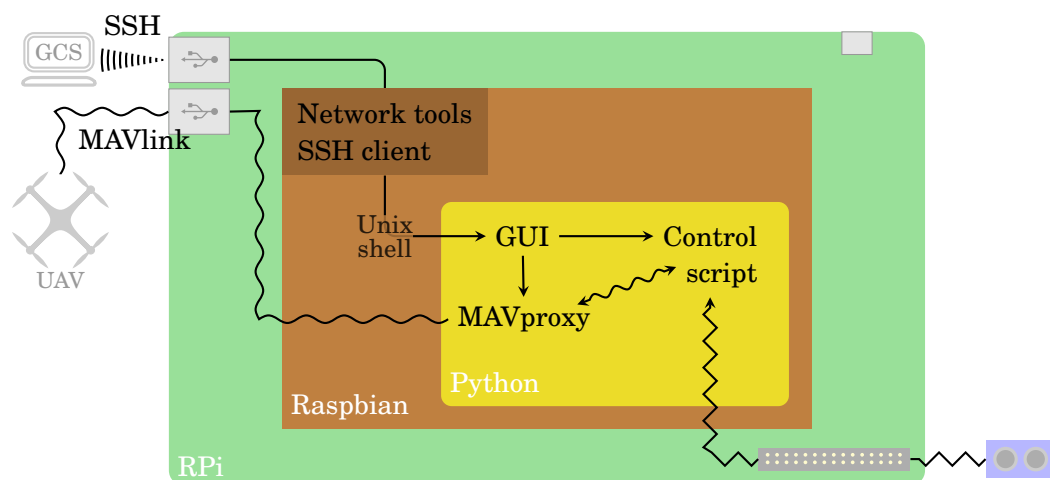

Figure 6.10: Software architecture of the OCAS computer

As it can be deduced from Figure 6.10, all the interaction from the Ground Control Station to the OCAS computer is performed through the Unix Shell, which only provides a command interface with the user. Nevertheless, the SSH connection allows an optional X Window System protocol forwarding (as mentioned in Section 6.1.2); and a Graphical User Interface (GUI) will be developed in response to Requirement 8.1, allowing the execution of MAVproxy as well as the custom control scripts graphically in order to enhance the intuitive operation of the system by the pilot.

### 6.4.2 MAVproxy

MAVproxy is an open-source Ground Control Station piece of software that is distributed as a Python application. Thus, it can be run on any machine on which a Python distribution can be installed (virtually any operating system).

Its most significant difference compared with traditional GCS software such as Mission Planner or QGroundControl is that MAVproxy is built for the command line and does not need a graphical desktop environment to operate (although a small state window and map are also implemented), which means that it is the most adequate alternative for the operation of the UAV from the OCAS. Furthermore, another decisive feature is the ability of MAVproxy of forwarding the MAVlink messages that are received from and sent to the UAV, allowing the possibility of operating as an intermediate software layer between the UAV and other GCS pieces of software. This functionality in particular shapes the chosen architecture for the OCAS in terms of communication between the UAV and the custom control scripts, which will be covered in Section 6.5.

Concerning the present section, the setup of MAVproxy will be explained.

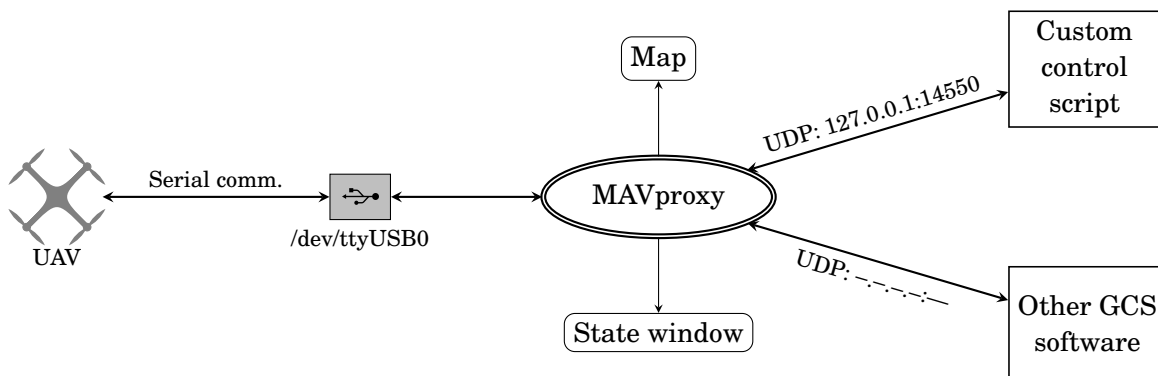

Figure 6.11: MAVproxy setup

As previously mentioned and shown in Figure 6.11, the connection from the UAV to the Raspberry Pi is done via a serial communication through USB cable. The Ardupilot software utilises a baud rate of 115200 bd/s by default, which is an important parameter that needs to be specified to MAVproxy before connecting to the vehicle (else the connection will fail). In addition, the address given by the OS to the USB port (/dev/ttyUSB0 in Figure 6.11) has to be provided too.

Finally, the redirection of MAVlink messages is done via the User Datagram Protocol (UDP), making use of the Internet Transport Layer. However, a remote Internet connection is not needed, since both MAVproxy and the intended target (the custom control script) will be running on the same machine; hence the local IP address can be used (127.0.0.1) together with any available port of choice. The optional second rerouting path is to be defined at the operator's discretion, and can be either a local or remote address.

The auxiliary Map and State windows are internally created by MAVproxy, using only Python function calls and libraries.

For completeness, the command to be executed in order to run the MAVproxy GCS software with the mentioned settings is:

```
1 $ sudo mavproxy.py --master=/dev/ttyUSB0 --baud=115200 --out=127.0.0.1:14550 --out=127.0.0.1:14551
```

### 6.4.3 The Python environment

Python is an open-source general-purpose programming language built to be powerful and easy to use. Additionally, it is implemented to run on virtually any machine, providing interpreters and compilers for most of the operating systems available, which means that the source code can be seamlessly ported from one system to another without any modifications to the source code. Furthermore, Python has a considerable community of developers that contribute to the development of the language through a vast repository of libraries which allow for a greater abstraction and automation of common tasks.

These features and flexibility of Python make it ideal for the development of the OCAS. In particular, there exists a community of developers led by 3D Robotics who are creating an Application Programming Interface (API) that provides several useful tools for the communication and operation of Ardupilot-based UAVs. For instance, DroneKit API<sup>1</sup> creates a `vehicle` class upon connection to a MAVlink stream (both serial and UDP protocols are supported) which is automatically updated at a rate of 50 Hz and stores the instantaneous values of important state variables of the UAV, such as absolute GPS position (latitude, longitude, altitude), relative position with respect to the take-off location (north, east, down) or velocity in the body-fixed reference frame, among others. Moreover, it also provides some routines that translate commands like *take-off*, *change flight mode* or guiding instructions and reference states into MAVlink messages that can be readily sent to the UAV through the `vehicle` class.

In addition, DroneKit includes a branch of development that aims to provide other developers with an Ardupilot Simulator. The approach taken is to simulate the Arduino control board and other hardware on the UAV by means of software, hence the name Software-In-The-Loop (SITL) simulator. However, DroneKit-SITL does not aim to provide an accurate physical representation of the UAV [8], since the physical properties change from vehicle to vehicle; the main goal of the simulator is to emulate the Ardupilot firmware, so that MAVlink communication and commands can be safely tested prior to their implementation on the physical platform. Conveniently enough, DroneKit-SITL can be installed as a Python application, and outputs the MAVlink messages via the TCP Internet protocol, which is additionally supported by MAVlink as an input data stream, similarly to the Serial communication by the real UAV.

---

<sup>1</sup>Documentation can be found at [www.dronekit.io](http://www.dronekit.io)

Additional documentation on the DroneKit project can be found on their webpage: [python.dronekit.io/](http://python.dronekit.io/).

## 6.5 The Python script

At this point it can be useful to collect all the information generated in Chapters 5 and 6 to determine what functions and components have still not been covered and shall be implemented within the custom control script. To that end, an allocation matrix can be created as represented in Table 6.2. In this matrix, the functions as defined in Figure 5.3, the subsystems from Figure 5.11 (software branch) and the implementation in Chapter 6 up to this point will be related. Besides, a fourth column will represent the structure that the Python script will follow, and will be used during its development and coding phases.

Function	Logical component	Actual component	Script component
GCS data-link	GCS connector	WiFi / SSH	
Start OCAS	GCS connector	GUI	GUI
Send data to GCS	GCS connector	SSH	
Log information	Program driver	Script	Logger
Stop OCAS	GCS connector	SSH	SSH
UAV communication	UAV connector	Script	DroneKit API
Monitor environment	Sonar operator	Script	Sonar class
Determine distance	Sonar operator	Script	Sonar class
Determine velocity	Sonar operator	Script	Sonar class
Confirm detection	Signal processor	Script	Sonar class
Level of threat	Signal processor	Script	Sonar class
Decide on action	Signal processor	Script	Auto class
Compute trajectory	Sonar operator	Script	Sonar class
Determine actuation	Actuation calculator	Script	main
Command actuation	UAV connector	Script	DroneKit API

Table 6.2: Functional and component allocation matrix

As it can be noticed, there are some script components that have not been made modular (encapsulated in a class). The reason is that those actions are very dependent on the actual computational approach taken by the developer, and can become significantly complex algorithms. Since the development of those algorithms is not within the objectives of the project, the coding phase has been simplified by inserting those functions directly into the main function as simple routines, even though if complex functionality is to be implemented, the most adequate approach would be to create classes to group all the related information needed to perform those tasks.

### 6.5.1 Script architecture

The tasks to be performed by the script are quite time dependent, since they have to be executed alongside the main mission. Thus, the nature of the script needs to be relatively sequential (following the functional paths from the FFBD in Figures 5.5 to 5.10). Nevertheless, the Functional Diagrams also show that some tasks need to be performed simultaneously for the correct execution of the mission. Hence, for the diverging paths in Figure 6.12, a multi-threading processing approach has been implemented on the functions that are to be evaluated in parallel to each other.

Figure 6.12 represents the `main.py` file within the script, from which additional classes and methods are derived and used during execution. For instance, the “Observe state” blocks are indeed performed by the Sensor operator from the PBS, and has been implemented as a set of variables and methods within the Sonar class, allowing for example for the simplified operation of multiple rangefinders by creating multiple instances of the same class.

In the following subsections within Section 6.5, all the functionality of the Python script will be explored, starting from the auxiliary classes and functions to finally combine all the missing parts of the Obstacle Collision Avoidance System into the main Python script. The complete Python files will be included in the Appendices for completeness.

### 6.5.2 Multi-threading capabilities

As mentioned earlier, it is important for the OCAS to execute several critical tasks at in parallel, avoiding interference between them. Fortunately, Raspbian is a multitasking Operating System, and Python provides a `threading` library that manages the system calls invisibly to the user (more information and derived methods can be found on [docs.python.org/2/library/threading.html](https://docs.python.org/2/library/threading.html)).

For achieving better accessibility, the `thrd` class has been developed to allow calls to the `threading` library to perform actions defined by functions which might or might not demand additional arguments. The complete code is copied in Appendix D.

### 6.5.3 Log information

Information report is done from the script in two manners: text with relevant data is immediately printed on the GCS screen through the SSH connection, but additionally those same messages are stored in a dedicated log folder contained in the script’s directory with precise information on the time each event is recorded. The logs are handled with the `logging` library, which is set up at the beginning of the main file as shown in Appendix E.

Additional information on the `logging` library can be found on [docs.python.org/2/library/logging.html](https://docs.python.org/2/library/logging.html).



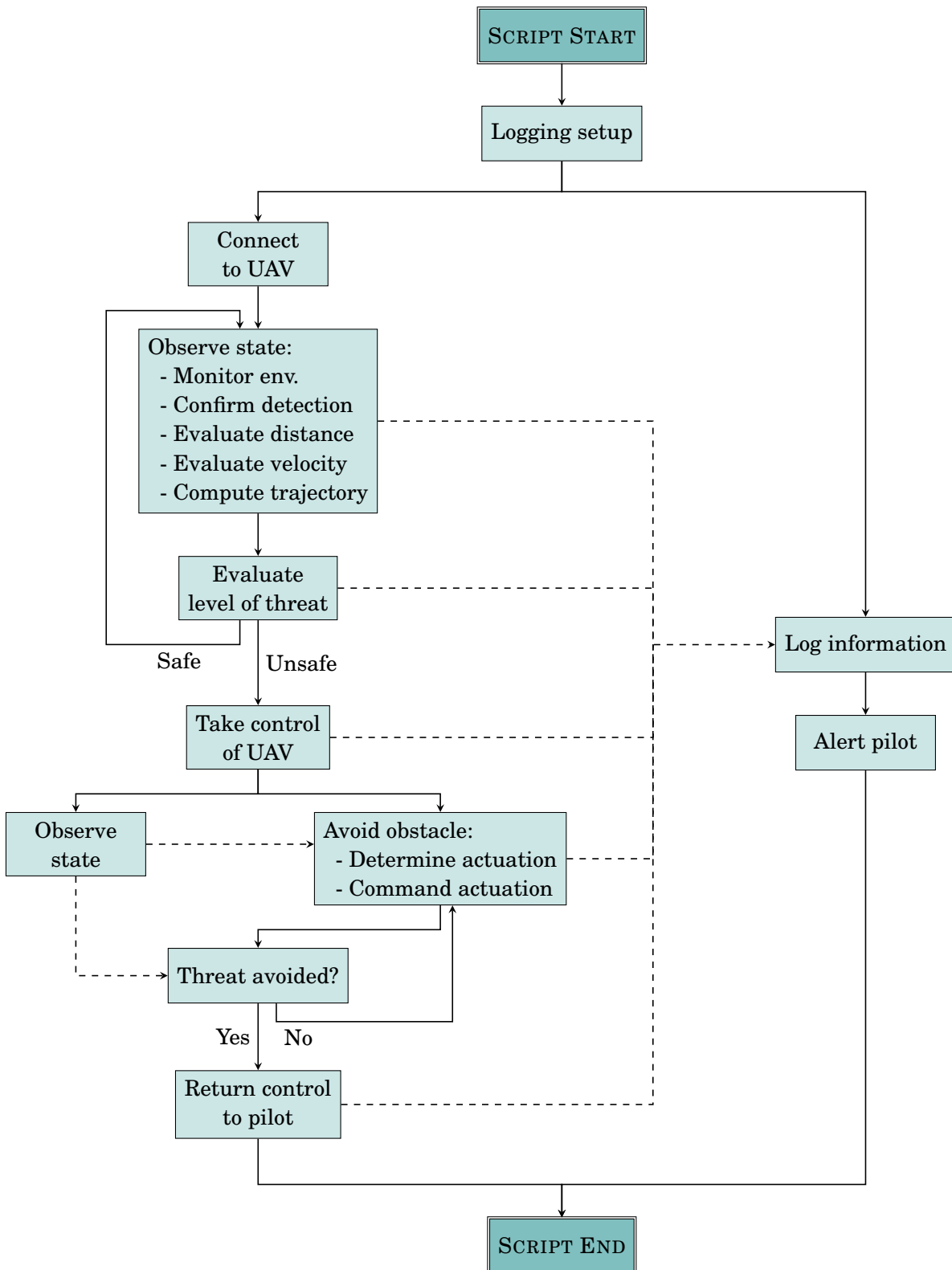

Figure 6.12: Functional flow diagram of the Python script

### 6.5.4 Connect to UAV

The file `connect.py` (see Appendix F) defines the function `Connect()` which conveniently encapsulates the function `dronekit.connect`<sup>2</sup> and makes the default arguments equal to the output settings of MAVproxy as defined in Section 6.4.2. In addition, the syntax `Connect(mode, address)` can be used for the cases when MAVproxy is not set up to work as an intermediate layer, accepting the Serial, UDP and TCP communication protocols on any local or remote address.

The output of the function is the `vehicle` class which handles all the communications with the UAV (through MAVproxy or otherwise) and updates the values of the state variables automatically on the background, as well as providing some convenient methods for interacting with it.

### 6.5.5 Observe state

The `Sonar` class performs the most important functions of the OCAS. It is not only responsible for operating the ultrasonic rangefinders via the built-in `RPi.GPIO` library, but also performs some basic signal processing to determine the speed and velocity of the UAV with respect to the detected obstacle, deciding if it could become a threat for the flight and triggering the avoidance manoeuvre. In the future, it might be interesting that these functions, which in principle could contain rather complex algorithms and processing techniques, would be developed in separate classes to enhance the modularity and upgradeability of the system.

The `Sonar` class defines three different methods which operate the sonar and calculate the distance to the closest obstacle, compute the velocity from distance measurements and evaluate the potential of a collision to trigger the avoiding manoeuvre, respectively, as can be seen in Appendix G.

#### 6.5.5.1 Measure distance

The `measureDistance()` (Appendix G. Lines 41 to 91) method triggers the ultrasonic rangefinder defined at the initialisation (`__init__()`) of the class to take a measurement following the procedure from the technical documentation of the sensor (Appendix C), which specifies to start with the Trigger pin in LOW state, change it to HIGH state for at least  $10\ \mu s$ , and return to LOW state. These commands are sent in a parallel thread, created with the `thrd` class, to avoid timing issues with the main script. After the Trigger signal is sent, two system interrupts are set with the help of the Raspberry Pi's GPIO library to listen to the Echo pin for both the rising and falling edge, storing the times at which they happen. The distance to the obstacle can be calculated with the flight time of the ultrasonic signal, which has the same duration as the HIGH state time of the Echo signal returned by the sonar, with Equation (6.2) where  $d$  is the distance to the obstacle,

---

<sup>2</sup>In Python, functions derived from libraries prepend the name of the library to the function itself, separated by the “dot” syntax

$t_{echo}$  is the time of the HIGH state in the Echo pin and  $a(T)$  is the speed of propagation of sound.

$$(6.2) \quad d = a(T) \times \frac{t_{echo}}{2}$$

Unfortunately, the speed of sound depends on the temperature of the air it propagates through. Thus, if the most accurate results were to be achieved, a temperature sensor should be integrated to compensate for temperature variations during operation. Nevertheless, the effect that reasonable temperature fluctuations have on the final measured distance is relatively small, as shown in Appendix K, and can be effectively neglected, setting  $a(T) = 340m/s$  as the standard and constant value for the speed of sound.

Occasionally, the rangefinders give incorrect measurements (probably due to multipath errors, cross-interference or noise) that can make the algorithms believe that the UAV is moving closer or faster to the detected obstacle than reality, which causes false-positive activation of the avoidance procedures. To prevent these kind of errors, a rolling average with a default window of 5 measurements is computed on the distance, even though more advanced filtering techniques could be implemented in the future, ranging from a basic low-pass filter to the more complex Extended Kalman Filter (EKF) combined with IMU data [27], for instance.

### 6.5.5.2 Compute velocity

The `computeVelocity()` method in the `Sonar` class computes the speed of the vehicle with respect to its closest detected obstacle. Notice that since the ultrasonic rangefinders are non-directional (they provide the distance to the obstacle regardless of the direction it is found, as long as it lies within its field of view), the returned speed is effectively the normal component of the velocity vector of the UAV with respect to the obstacle.

Again, due to noise issues, the signal should be filtered before being fed to the decision module; but this time the rolling average does not seem appropriate since the velocity can be modified at a fairly high rate on quadcopter vehicles as is the case for the testing platform. Thus, a first-order, three-data-points backward difference approach is suggested [6], since it provides convenient damping properties, although higher-order or bigger stencil approximations would also be appropriate.

The mathematical derivation is as follows:

The normal component of velocity obeys the equation

$$(6.3) \quad v = \frac{dx}{dt}$$

where  $x$  is the distance measurement taken by the ultrasonic rangefinder.

Performing the Taylor expansion to that equation at both the previous data point and its preceding, that is, at  $t_1 = t_0 - \Delta t_1$  and  $t_2 = t_0 - \Delta t_2$  being  $t_0$  the most recent data point, the

expressions obtained, respectively, are:

$$(6.4) \quad x_1 = x(t_1) = x(t_0) - \left. \frac{dx}{dt} \right|_{t_0} (t_0 - t_1) + \mathcal{O}(\Delta t^2)$$

$$(6.5) \quad x_2 = x(t_2) = x(t_0) - \left. \frac{dx}{dt} \right|_{t_0} (t_0 - t_2) + \mathcal{O}(\Delta t^2)$$

Summing both equations together:

$$(6.6) \quad x_1 + x_2 = 2x_0 - \left. \frac{dx}{dt} \right|_{t_0} [(t_0 - t_1) + (t_0 - t_2)]$$

Since  $\left. \frac{dx}{dt} \right|_{t_0} = v(t_0)$ :

$$(6.7) \quad v(t_0) = v_0 = \frac{2x_0 - x_1 - x_2}{2t_0 - t_1 - t_2}$$

From equation (6.7),  $v_0$  is the returned value that is used to predict a potential collision.

### 6.5.5.3 Calculate collision

To successfully predict a potential collision, the future state of the vehicle shall be estimated. For the first prototype, the collision will be anticipated considering the present position and velocity of the UAV with respect to the closest obstacle, together with some intrinsic parameters.

The algorithm computes the parameter  $t_{safe}$  which encapsulates all the available information so that when  $t_{safe} < 0$ , a collision is expected to happen.

$$(6.8) \quad t_{safe} = t_{collision} - t_{reaction} - t_{stop} - t_{margin}$$

From equation (6.8),  $t_{collision}$  is the estimated time to the obstacle computed with the actual velocity as computed in Section 6.5.5.2,  $t_{reaction}$  is the time taken by the Python script to actually take control of the UAV after the obstacle situation has been considered as unsafe,  $t_{stop}$  can be estimated according to the avoidance procedure as the time it would take to completely stop the vehicle after control has been taken by the script, and finally  $t_{margin}$  is a figure representing the clearance to the obstacle after the avoidance manoeuvre is complete, also accounting for possible sensor errors, as shown in Figure 6.13.

### 6.5.6 Take control of UAV

When the condition is met that the UAV is approaching the detected obstacle and  $t_{safe}$  is calculated as smaller than zero, the trigger is released for the Python script to take control in order to avoid the collision. The most appropriate way, as explained in Section 3.3, is to activate Ardupilot's Guided mode to allow the script to send commands to the UAV in real time.

Thus, the Control class defines the methods `take()`, `checkTake()`, `give()` and `checkGive()` which, when called in pairs, perform the actions given as arguments (e.g. send a MAVlink

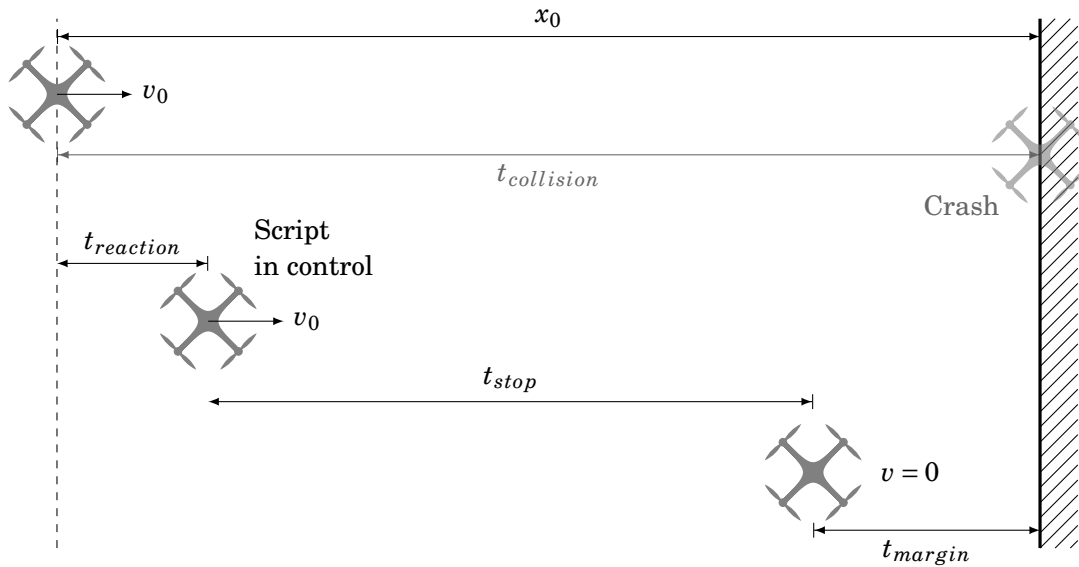

Figure 6.13: Prediction of a collision by the OCAS

command to the UAV) while simultaneously check for a certain condition to be met (for instance: the message was successfully sent, the vehicle has stopped or reached the commanded position, etc.), both in independent parallel threads to avoid interference with the main function or with themselves (the complete code can be found in Appendix H).

Finally, when both the `take()` and `checkTake()` threads are terminated (indicating that the action was successful) the script advances to the so called “autonomous flight”, which in the Python script’s scope represents the avoidance manoeuvre, not to be confused with Ardupilot’s Auto mode.

### 6.5.7 Avoid obstacle

The obstacle avoidance phase can be accomplished in a wide variety of actions, from real-time control to higher-level trajectory planning. However, being Ardupilot the main controller of the UAV, some of its features can be used to make the algorithms simpler in this first proof of concept.

For example, the default behaviour of the quadcopter UAV when Guided mode is activated and no other MAVlink command is received from the GCS (or the OCAS) is to loiter in place by making use of the GPS data, which is a reasonably effective manner of preventing the collision by completely stopping the vehicle.

Furthermore, the MAVlink protocol defines several message headers which allow for the straightforward definition of the desired position or velocity, being responsible for the state transitions the Ardupilot board itself. Thus, any function defining a MAVlink command can be passed to the `Auto` class (full code in Appendix I) which, operating in a similar manner as the `Control` class, performs the specified action in one thread while a second one checks for a

condition to be satisfied before killing the first thread and itself, hence considering the avoidance manoeuvre as complete.

### 6.5.8 Return control to the pilot

Once the obstacle is considered to be cleared, control needs to be returned to the pilot in a safe manner. The procedure is handled by the `Control` class's methods `give()` and `checkGive()` in an identical way as explained in Section 6.5.6.

Besides, it has been found that the most appropriate action to return control is to change to Altitude Hold mode, since such mode will try to balance the UAV while maintaining a constant altitude, provided that the control sticks of the transmitter are in a centred position.

### 6.5.9 The “main” file

Finally, the `main.py` file is what should be executed by the pilot. It contains the required sequential calls to the previously mentioned functions and methods, together with the definition of the functions that are passed to them as arguments.

The complete file can be found in Appendix J, but the main blocks it is divided in are:

1. Import of the relevant libraries and files.
2. Logging setup, as explained in Section 6.5.3.
3. Connect to the vehicle (Section 6.5.4), returning the `vehicle` class.
4. Operate and monitor the information from the ultrasonic rangefinders (Section 6.5.5). This phase will not be exited until  $t_{safe} < 0$ .
5. Take control of the vehicle, changing to Guided mode as explained in Section 6.5.6.
6. Perform the manoeuvre to avoid the detected obstacle (Section 6.5.7). The manoeuvre is also defined within this step, and passed as argument to the `Auto` class.
7. Safely return control to the pilot, as described in Section 6.5.8.
8. End the script by closing the external connections and resetting the GPIO pins on the Raspberry Pi (to avoid errors on subsequent executions).

## 6.6 Graphical User Interface

The task of the GUI is to facilitate the operation of the OCAS by a briefly trained pilot without much knowledge on Linux systems. Hence the GUI shall be able to generate the software architecture depicted in Figure 6.11 effortlessly every time the OCAS is initialised.

A graphical Python application has been created with that purpose, making use of the Tkinter library, whose code can be seen in Appendix L, with further documentation on docs.python.org/2/library/tkinter.html. A screenshot of the application itself is shown in Figure 6.14.

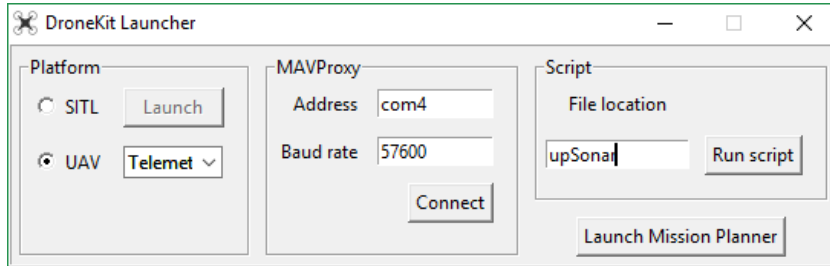

(a) Windows version

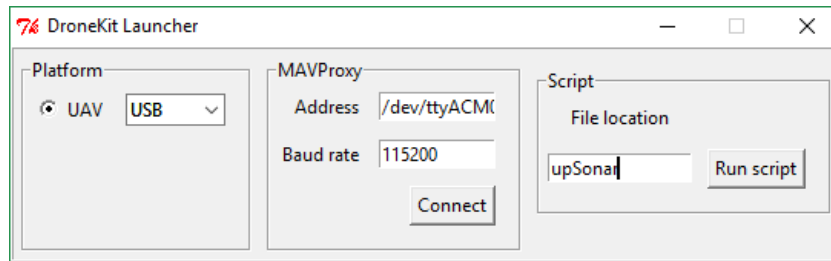

(b) Linux version

Figure 6.14: Graphical User Interface

As it can be seen, the two versions have minimal differences. Mainly, the Windows version, which was used in the early testing phases, provides the options of launching the SITL simulator as well as the Mission Planner GCS software for in-depth analysis of the incoming data (the lower branch in Figure 6.11). Also, both versions autocomplete the MAVproxy fields according to the system they are run from, minimising errors and avoiding the memorisation of parameters by the pilot.

## 6.7 Hardware implementation

The default configuration of the F450 frame is with the main battery directly on top and the Ardupilot board between the upper and lower plates, to better avoid shocks and electromagnetic noise from the motors, as shown in Figure 6.15

However, the inclusion of the OCAS, with its independent power source, sensors and computer board, implies that the platform needs to be modified in order to fit the additional components. The followed approach is to add a second bottom plate below the original one, separated by 5 cm. Also, the landing gear shall be extended to avoid touching ground with the belly of the vehicle.

The distribution of the components had to be altered to improve the stability and accessibility



Figure 6.15: Default F450 configuration. Source: rcgroups.com

of the UAV, moving the heavy main battery to the lower deck and mounting the Raspberry Pi and its power source on the upper plate. Room was also made for the sensor mount and the WiFi adapter over the lower plate, next to the main battery.

The resulting platform is displayed in Figure 6.16.

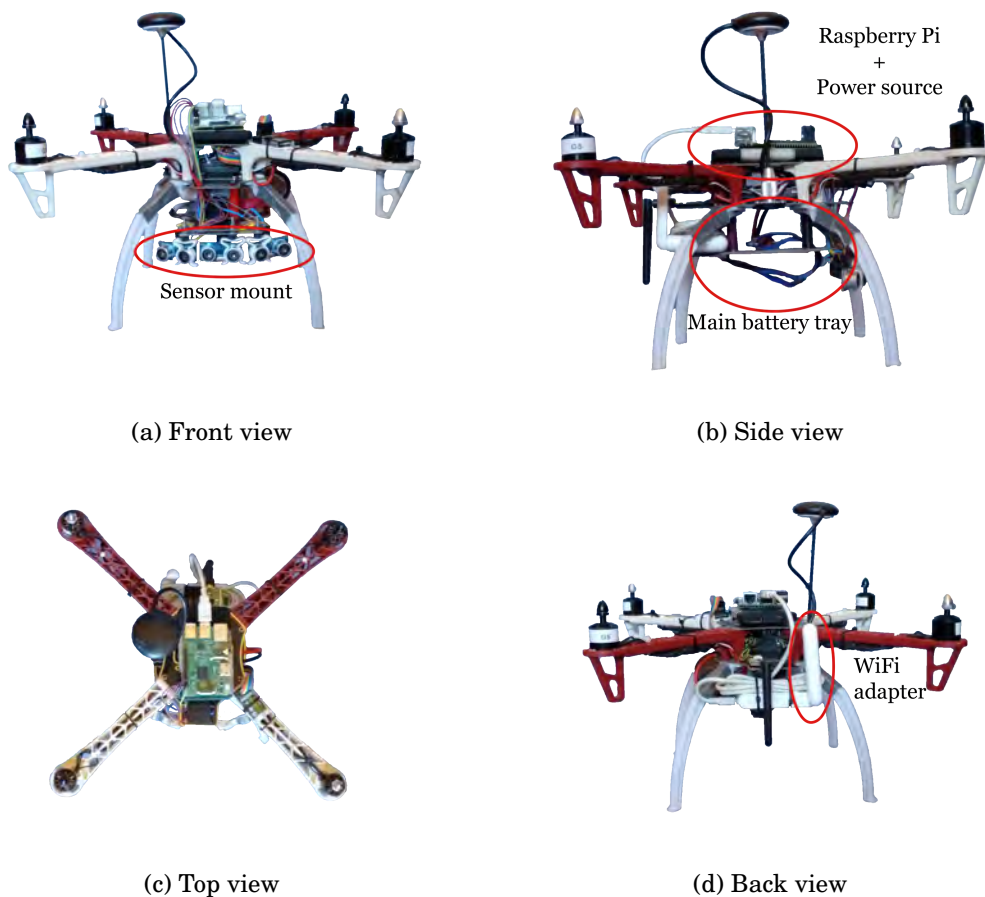

Figure 6.16: Final platform architecture



Notice that the F450 platform is not designed to carry the OCAS. This fact imposes some limitations to the UAV since the weight is significantly increased, affecting manoeuvrability and flight time. Nevertheless, the main purpose of this project is not to develop the platform, being the existing one adequate enough for the testing phase of the OCAS.



## TESTING AND RESULTS

In order to prove the effectiveness of the Obstacle Collision Avoidance System, it needs to be tested to check that it meets the requirements and design specifications. Hence, a set of individual tests have to be designed to assess the capabilities of each of the components involved in the system.

The present chapter will cover the experimental setups and results of those experiments performed on the critical components, subsystems and, finally, the system as a whole in a realistic environment.

### 7.1 Testing methods

Most of the testing was done in parallel to the implementation of the design into the real product, ensuring that the system was built over robust and properly working components, since possible modifications to the design are significantly more costly the later the development phase in which errors are detected (see Figure 5.1). Furthermore, tests can give valuable insight on the functioning of the components, which can prove useful in the decision making process within the implementation stages, effectively improving the overall performance of the system.

Thus, the actions described in this chapter can be seen as complementary and, in some sense also contributing, to the implementation phase of the OCAS.

#### 7.1.1 Component testing

The validation of each individual component is assumed to be successfully done by the manufacturer. Therefore, comprehensive testing will only be performed on the parts of the system that have been actively developed during the execution of this project, such as the interfaces and the

operation algorithms of the ultrasonic rangefinders, since they are a critical component of the OCAS.

#### 7.1.1.1 Interfaces

Assuming that the stock UAV interfaces (RC transmitter / receiver, telemetry link with GCS) are already tested and working, the connections to be verified are those involving the OCAS only, shown in Figure 6.6. In particular, the GCS connection over WiFi is of higher interest, since the power connection is straightforward to check by ensuring that the Raspberry Pi boots when plugged; and the MAVlink serial connection should not entail any difficulty once the appropriate communication port and baud rate are selected upon startup of MAVproxy (which is automatically done when using the GUI for that purpose). Also, the testing of the GPIO connection will be covered in Section 7.1.1.2.

Concerning the network connection of the Raspberry Pi, it is controlled by the Raspbian OS. Having set up the ad-hoc network from the Windows machine at the GCS as specified in Appendix A, the Dynamic Host Configuration Protocol (DHCP) server should be properly configured to imitate the Local Area Network (LAN) settings to which the GCS machine is connected. Thus, the DHCP service will provide the Raspberry Pi with a compatible IP, together with other important network parameters, automatically.

Nevertheless, the problem with DHCP is that the address of the computers connected to the network will occasionally change, altering the settings for a successful SSH connection (those varying settings can be found by following the steps in Appendix B). Thus, for a more convenient debugging option, a static IP interface was selected on the Raspberry Pi's ethernet port.

Finally, in order to resemble the described setting on the Raspberry Pi, the configuration must be done by modifying the `interfaces` file which is present in all Debian-based Operating Systems at `/etc/network/interfaces`. The specific file for the OCAS computer board is copied in Appendix M for completeness, together with an example of the `wpa_supplicant.conf` file which holds the parameters for the wireless network connections.

In terms of the evaluation of the connection, within the scope of the project, it is considered that the interface is successfully connected if the communication is responsive and stable, which can be certainly proven by construction<sup>1</sup>, following the steps in Appendices A and B.

#### 7.1.1.2 Ultrasonic rangefinders

The selected HC-SR04 sensors are mainly built to be connected to Arduino microcontrollers, which operate at 5 V. Hence, in order to obtain some familiarity with their usage, as documented by the manufacturer (see Appendix C), the operation was initially made from an Arduino Mega board,

---

<sup>1</sup>From Wolfram Mathworld: A constructive proof is a proof that directly provides a specific example, or which gives an algorithm for producing an example. Constructive proofs are also called demonstrative proofs

which would trigger the ultrasonic signal and receive the processed echo to be transformed into the distance to the closest obstacle.

Ensuring that all the connections on the Arduino board were successful, the following logical step is to perform the same test from the Raspberry Pi, which inherits the inclusion of the voltage dividers (Figure 6.8) and the Python GPIO libraries. It was during this stage that the Sonar class was developed, requiring only a “driver” file which would make calls to the Sonar’s methods, and can be found in Appendix N.

Apart from triggering the ultrasonic rangefinders, the driver file would print the measured distance for any amount of attached sensors and display a graph with their values together with the calculated velocity, to help with their study in the Results section.

On the hardware side, it is known that the ultrasonic rangefinders are rather directional sensors and do not perform at their best if the obstacle is not situated directly on the symmetry plane. In order to assess the maximum spatial capability of the sensors, a 4m<sup>2</sup> aluminium plate was used as object to be detected, placing it in various positions in order to determine the spatial range limits in terms of maximum angles at which the ultrasonic signal is adequately reflected back to the sensor, getting a successful reading on the distance.

### 7.1.2 Software testing: SITL

Prior to the implementation of the OCAS in the real UAV, and knowing by individual tests that the hardware components were working properly, it was necessary to test the definition of the MAVlink messages that were to be sent to control the UAV in flight. Furthermore, it was of utmost importance that the navigation coordinates were correctly defined, and also the transformations between different reference systems, since the MAVlink protocol only supports commands in the global (latitude, longitude, altitude) reference system, while for physical obstacle navigation it is more convenient to define the procedures either in Flat Earth (North, East, Down) or even body fixed (x, y, z) reference frames, from which the transformations needed to be computed.

To ensure safety during the software testing phase, the scripts were initially tested in a simulator. In particular, the DroneKit development team provides a Software-In-The-Loop (SITL) simulator that works in a similar manner than a real Ardupilot UAV would.

Software-In-The-Loop means that, for the control algorithms, only software input is considered. Hence, the physical characteristics of the UAV, together with its default sensors (IMU, barometer, GPS. . .) all have what is considered to be a reasonably accurate software representation of their hardware counterparts (accuracy which, in the case of the SITL simulator, is not where the emphasis has been put as studied in [8]). Nevertheless, the existent inaccuracies do not present any major problems for the script testing since the closed-loop PID control algorithms ensure that disturbances and errors are cancelled, finally reaching the requested state albeit by taking slightly different transient responses.

What is of higher importance in the software testing phase is the actual interpretation of the MAVlink commands by the Ardupilot control board, and the general physical response to them. Fortunately, it is in the Ardupilot firmware simulation where the SITL software excels, since the simulator runs the exact same source code, only adapted to run on a regular computer rather than an Arduino board and to receive input from the software models rather than the real sensors.

However, the simulation of the default sensors via software means that the OCAS is not implemented (for being a custom build for this project). Thus, the  $t_{safe} < 0$  condition can not be computed in the simulated environment. For the purpose of testing, the sonars step in the `main.py` file of the custom script was adapted to include the monitorisation of Channel 7 on the RC transmitter, which would cause the same reaction as the ultrasonic rangefinders at the change of state of the corresponding switch, by modifying the lines 41 to 93 on Appendix J by the fragment of code in Appendix O, accompanied by the `Observe` class from Appendix P.

Finally, it is worth mentioning the role of the simulator within the rest of the subsystems of the OCAS, since SITL is only aimed at replacing the UAV block from Figure 6.6. The MAVlink stream of data out of the simulator is transmitted using the TCP protocol, which can be substituted in the MAVproxy startup options instead of the serial address that is used for the connection with the UAV. Hence, the two leftmost blocks in Figure 6.11 would be substituted by the simulator, with the TCP interface with MAVproxy, being this change completely transparent to the Python script, which does not need any further modification.

In addition, in the Windows version of the GUI application, the option to launch the simulator and autocomplete the address and port fields on the MAVproxy parameters (see Figure 6.14) was included to facilitate the testing stages of the project, together with the Mission Planner button, which greatly simplify the testing workflow.

### 7.1.3 System testing

As the last step in the validation process, the OCAS shall be tested as a complete system in a realistic scenario. For that purpose, the full operative UAS was taken to a flight field and flown against a simulated soft (cardboard) obstacle to avoid any serious damage in case of failure, as shown in Figure 7.1. In this stage, the logs (defined in Section 6.5.3) acquire maximum importance since they allow to compare and contrast the data and sequence of events with the video footage from the tests.



Figure 7.1: Testing obstacle

## 7.2 Results

In the present section, the results concerning the previously described tests from which a valuable lesson can be extracted will be discussed. Successful tests in which the systems work as expected will be left out of the discussion in the case that they do not contribute to any further knowledge on the functioning of the system.

### 7.2.1 Ultrasonic rangefinders

Two main issues appeared when assessing the performance of the sonars: First, the Field Of View (FOV) of each individual sensor is quite limited, which encouraged for the incorporation of an array of several sensor with slightly different orientations to cover a wider range. On the other hand, the implementation of more than one rangefinder created some unwanted effects when operating simultaneously, since the signal from one of them could be seen as the echo reflection of the previously triggered sensor, causing ghost signals and bad readings.

In terms of the sonar's capabilities, the tests with the aluminium plate as obstacle placed at approximately 2 m from the sensor unveiled that their maximum FOV against a large surface completely perpendicular to the line of sight is of  $35^\circ$ , while the maximum inclination that reflects a valid signal is of  $20^\circ$  with respect to the plane of symmetry, as shown in Figure 7.2.

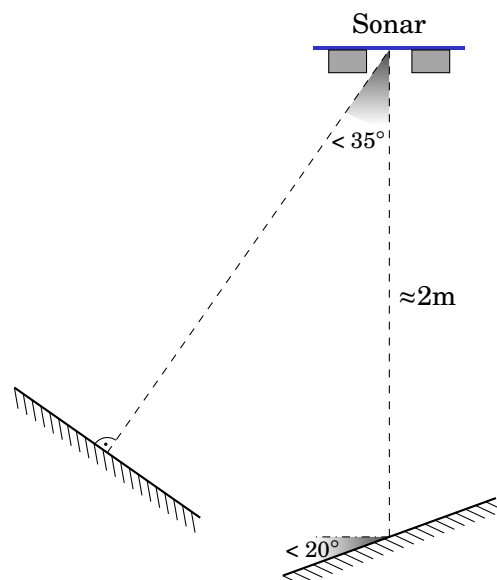

Figure 7.2: Ultrasonic rangefinder FOV test setup

These limitations in the maximum FOV imply that more than one sensor with slightly different orientations shall be used to cover the complete space in front of the UAV. For the first prototype, 3 sonars were mounted with approximately  $20^\circ$  between them, which ensures that the complete frontal path is covered during forward flight.

However, operating more than one ultrasonic rangefinder generates an additional problem, since they generate and receive identical signals for their measurements, implying that the signal generated from one sensor can be captured by a different one, creating misleading signal flight times. This problem can be mitigated in two different ways. First, triggering the sonars all at the same time would generate an assortment of similar signals from which no sensible discrimination can be done; the solution is to send the trigger signals at different intervals in time, ensuring that the echo signal from one sonar is received before the trigger signal of the next one is sent. Nevertheless, there can still be lost signals and multipath errors which need to be alleviated. Thus, the second step can be to filter the signals to account for suspicious discrepancies, which in the scope of the first prototype was done by performing the rolling average of the last several measurements (see Section 6.5.5.1), although more advanced signal processing techniques can definitely provide better results.

### 7.2.2 Simulator

There is one essential difference between a simulator and reality: any simulator represents a model of the physical world, but the physical world is so complex that no simulator can achieve an infinitely precise representation of reality.

That being said, there are some physical effects that are not implemented in the SITL simulator. For example, the input from the simulated sensors perfectly represents the calculated state of the UAV, albeit with some artificial gaussian noise added to them according to their individual accuracy and response rates.

This fact became a problem when the SITL validated software was to be tested on the real UAV. For example, while the relative location computations and MAVlink commands appeared to work perfectly well in the simulator, there was some unknown phenomenon that was causing the real UAV to behave violently instead of maintaining the position when the Guided mode was activated by the script.

After several weeks trying to find the root of the problem, and analysing all the inputs that could be affecting the behaviour of the Ardupilot controller, it was concluded that, since the GPS sensor was a requirement for the loitering capabilities of the Guided mode, and the tests were being done in a controlled space within the city (see Figure 7.3), surrounded by high buildings, there was a significant chance that the reception of the very weak GPS signals from the satellites (orbiting in Medium Earth Orbit at around 20,200 km) were being blocked and / or affected by the surrounding walls.

This phenomenon is called multipath error: the GPS sensor can determine its position by receiving the signals from at least 4 satellites for which their location in the sky (ephemeris) and the precise time of transmission of those messages is known. By comparing the time of arrival of the signal with the time of emission, the GPS module can calculate the exact distance to that particular satellite. Then, by triangulating (intersecting the spherical loci of) those distances





Figure 7.3: Initial testing site within the city

(and solving for the clock bias), the global position of the vehicle can be precisely determined. However, the high propagation speed of the electromagnetic waves (speed of light,  $\approx 3 \times 10^8$  m/s) conveys that a small mismatch in the time of arrival of the signal can generate large errors in the final calculated distance from the GPS module to the satellite. Furthermore, the GPS signals can rebound on the walls of buildings, effectively covering more distance than the straight line that joins the satellite and the sensor, significantly magnifying the effect.

Once the possible source of error was pointed down, the only action needed to verify or discard it was to move to a countryside location for the tests, which indeed proved the multipath error to be the source of the unwanted behaviour of the UAV in the preceding tests.

The lesson to be learnt from these events is the dependence of the Guided mode on a high quality GPS signal, which implies that the solution presented in this thesis is not still applicable to indoor nor urban flight; at least not if the control commands encode information on the global location of the UAV. Nevertheless, in future work, some control procedures could be implemented in order to consider the input streams from the ultrasonic rangefinders as the main source of information for the navigation algorithms, overriding the RC transmitter channels directly instead of commanding higher level “go-to” manoeuvres to the Ardupilot control board.

### 7.2.3 UAS + OCAS

Finally, it is necessary to confirm that each of the subsystems are properly integrated and are able to work together for a common goal within the UAS. After a realistic flight test, the logged information provides some valuable insight on the execution of the tasks and their effectiveness

to actually avoid the collision with foreign obstacles.

For the selected flight test, vast amounts of data are recorded (more than 5000 individual messages) containing information on the complete state of the UAV as recorded from all the onboard sensors. Fortunately, since the particular script that was run defined as the avoidance manoeuvre to command a climb of the vehicle and the vehicle was flying mostly forward during the test, the different stages of the flight can be easily recognised from the relative altitude and the y-position with respect to the take off location in the body-fixed reference frame plots, depicted in Figures 7.4a and 7.4b, respectively.

Additionally to Ardupilot's logs, the data recorded from the Python script itself is overlaid to show the precise moments at which commands are being sent to the UAV, and its response to them, indicating who is in control of the vehicle as the test progresses. Furthermore, from the telemetry logs the flight modes of the UAV at any instant of time can be extracted, as are displayed at the bottom of the plot.

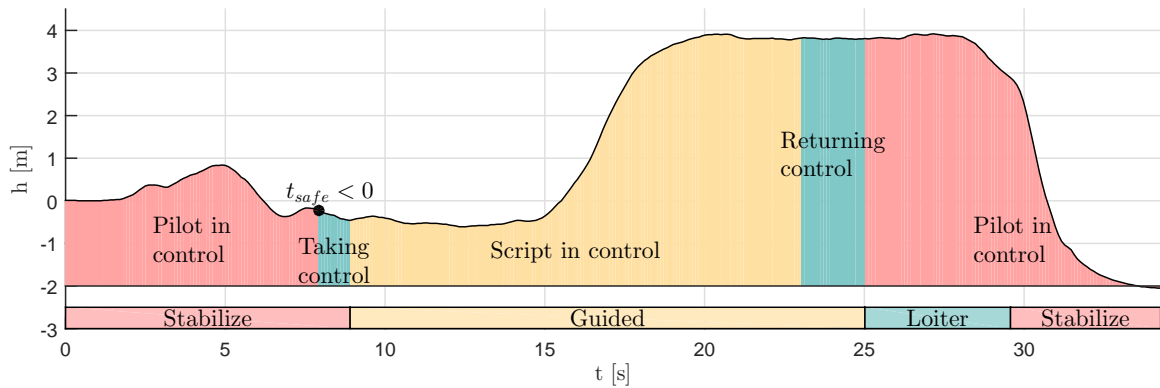

(a) Relative altitude during the flight test

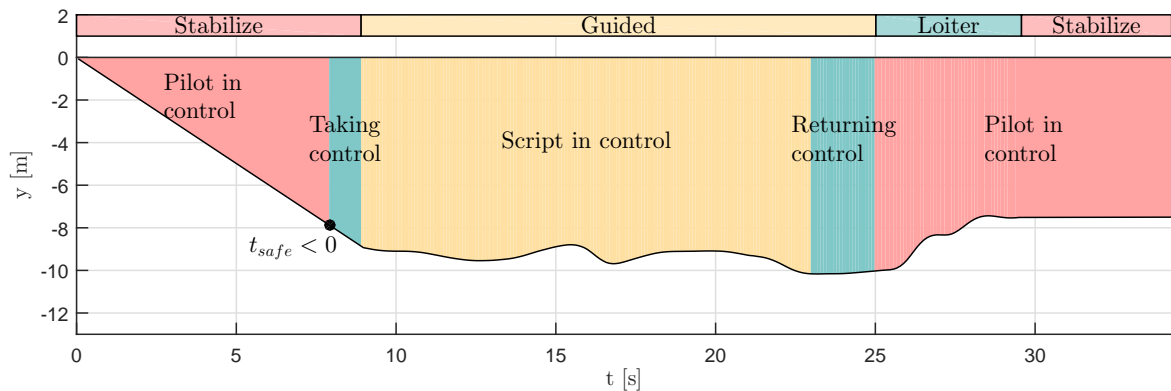

(b) Longitudinal position during the flight test

Figure 7.4: Results of the flight test

As it can be seen, the initial stages of the flight are quite unsteady on the altitude side while the pilot tries to approach the testing obstacle. Then, when the ultrasonic rangefinders determine

that the state of the UAV with respect to the obstacle is not safe enough, the Guided mode gets activated (after a  $\approx 1$  second delay), and the vehicle stabilises trying to keep the position of activation of the mode and effectively stopping the UAV while the command is sent. A set of functions translates the position that lies exactly 4 metres over the actual position of the UAV at the time of the computation and sends the MAVlink message to Ardupilot, which starts to climb to the commanded location, which will be maintained until the pilot is given back control. Notice that the GPS localisation is only accurate up to one metre, and small variations can be seen on the horizontal position of the UAV for that reason, while the altitude is better maintained during the Guided phase as a result of the more precise barometer.

After a small delay, the Python script assumes that the UAV has reached the commanded location, and proceeds to return control to the pilot, which takes  $\approx 2$  seconds. The control of the vehicle is given back to the pilot in Loiter mode, since it allows for adjustments in the horizontal plane while the vertical controls behave similarly to Altitude Hold mode (see Chapter 3), allowing for a smooth transition. Finally, the pilot changes back to Stabilize mode and performs the landing manually.

Observe that the landing altitude lies 2 metres below the reference take off altitude; such discrepancy is due to the fact that the take off was done from an elevated site to avoid false-positive activation of the avoidance stage by the reflection of the ultrasonic signals on the ground itself.



## CONCLUSIONS

The main goal of this thesis was to make unmanned flight more secure and flexible by means of a modular Obstacle Collision Avoidance System, as defined in Chapter 4. From the work done during the project, it can be concluded that:

- There exists a large capacity of improvement in terms of the safety levels that could be achieved during the operation of Unmanned Aerial Vehicles, being the Obstacle Avoidance feature a mere example of the available potential. Advanced communications, ADS-B surveillance, decentralised swarming... would also contribute to the common safety issue.
- There are several options in terms of environment sensing alternatives which provide various advantages and drawback to the OCAS in terms of range, accuracy or flexibility. The ultrasonic rangefinders have been chosen mainly for their ease of use and small processing requirements.
- The design phase of a complex system depends on a large amount of variables and assumptions, which are difficult to track if a systematic design procedure is not followed. For this project, as well as for the vast majority of systems developed by the most important companies, the Systems Engineering approach was selected for the orderly flow of ideas due to its proved reliability.
- The definition of interfaces is of utmost importance for the system to work as a whole and properly perform its functions. When two subsystems or components cannot communicate in a common language, an intermediate translation layer shall be created to translate the information. For example, between the UAV and the Python scripts, MAVproxy acted as a translator; or between the Python algorithms and MAVproxy, the DroneKit API translated the commands into usable MAVlink messages.

- Some decisions on the scripts architecture were made during the implementation and programming phases which nevertheless should have been made through the Systems Engineering methods applied to the design of each particular (software) subsystem.
- The theoretical or simulator-based inferences should be considered incomplete, and only blindly applicable to the scenarios that accurately represent the mathematical model being studied, as shown in Section 7.2.2.
- Systematically testing the design and implementation of the product and its components is a very important step in the development process, allowing to validate both the solution and the process itself, and avoiding later modifications of the system that could be really expensive to resolve in the production or operation phases.

Finally, it is worth mentioning that Systems Engineering is a much more exhaustive activity than what was shown in this thesis, involving a large set of engineers and specialists working on projects that span several years of development and implementation.

## 8.1 Summary of contributions

Naturally, the main body of this thesis (Chapters 5, 6 and 7) contains all the contributions that have been made to the field of UAVs during the execution of the project. Nonetheless, they will be summarised here for easier access:

- A conceptual safety layer has been designed to operate between the UAV and its physical surroundings. Such safety layer (the OCAS) gives additional information of the environment to the UAS so that more complex decisions can be made automatically, enhancing the situational awareness and overall safety of the vehicle.

During the design process, a study has been made on the requirements that should be fulfilled by the Obstacle Collision Avoidance System, together with a logical decomposition of its functional and physical architectures, and the definition of the interfaces with the rest of the UAS.

- The proposed design has been implemented into a prototype as a proof of concept, focusing on the integration of the system and the creation of the interfaces. This approach was followed after the belief that once the successful integration of the system is complete, it will hardly need any modification, simplifying future research on the technical problems that are still to be solved (information capture, signal processing...), while the robust baseline remains unchanged.

Naturally, the proposed implementation is just one among many different alternatives, and the capabilities of the OCAS could be extended or enhanced with some modifications to the solution, while still meeting the requirements and the architecture of the system.

- Finally, a working prototype has been built according to the design guidelines, testing it in a series of realistic scenarios which show that the proposed solution is completely functional and fulfills the problem statement from Chapter 4, representing a good baseline on which to base further research.

## 8.2 Future work

The development of a complex system like the OCAS can by no means be complete within the duration of one single Bachelor's Thesis. Thus, this project has been focused on providing a capable baseline on which to found future research. In particular, some of the ideas that have been generated during the execution of the project but could not be further developed even though they can be interesting to work on in the future are:

- The acquisition of data from the ultrasonic rangefinders can be greatly improved; from the location of the sensors for better spatial awareness to the triggering procedure, the noise filtering of the incoming signal to reduce false-positives or the processing of the data with more sophisticated algorithms to better predict a potential collision.
- The integration of alternative sensors, especially stereoscopic cameras but also radar or lidar, which can be more difficult to operate and extract useful information from than the sonar but also provide other advantages over it, as explained in Section 6.2.
- The improvement of the algorithms that predict the trajectory of the UAV with respect to the obstacle, to obtain a more reliable avoidance of potential collisions.
- The implementation of real-time control algorithms, in order to avoid the complete reliance on a quality GPS signal for the avoidance procedures.
- The automation / simplification of the connection of the GCS with the OCAS and the script initialisation procedures.
- The improvement of the testing platform, since the available one has serious limitations in terms of the flight duration and the additional weight that the OCAS entails.
- The application of the UAV + OCAS system to real life problems, such as precise positioning in GPS neglected areas, indoor / urban navigation, localisation and mapping (SLAM), etc.







## CREATION OF GCS WIRELESS NETWORK

The wireless network to which the OCAS will be connected for communication with the GCS shall meet two major requirements:

1. The network shall allow the wireless communication between the OCAS and the GCS via SSH protocol
2. The network should provide the OCAS with an internet connection (to allow for an easier Python scripts updating, programming, and debugging and the download of logs for analysis at the GCS via git)

Additionally, since the GCS consists of a Windows laptop, the tools to be used shall be compatible with the Windows 10 Operating System.

The simplest network architecture that allows for peer-to-peer communication of computers is the ad-hoc network. Furthermore, Windows 10 Professional provides all the tools required to create such a network, which will additionally share its main Internet connection with their peers when available.

The steps to be followed on the GCS for a successful connection of the OCAS to the Windows machine are:

1. Open a Command Prompt window as Administrator (network commands cannot be run by regular users for safety reasons)
2. Create a new ad-hoc network by running the command:

```
netsh wlan set hostednetwork ssid=quad_network key=*****
```

3. Start the newly created network, making it available for other devices to connect:

```
netsh wlan start hostednetwork
```

4. Edit the `wpa_supplicant.conf` file on the Raspberry Pi to include the settings from the ad-hoc network (see example in Appendix M)
5. If the Raspberry Pi does not automatically connect to the network, restart the wireless interface by running:

```
sudo ifdown wlan0
sudo ifup wlan0
```

6. Check that the Raspberry Pi is connected to the Windows' network by checking the MAC address of connected devices:

```
> netsh wlan show hostednetwork
```

```
Configuración de red hospedada
```

```
-----
```

```
Modo: permitido
Nombre de SSID      : "quad_network"
Nº máximo de clientes : 100
Autenticación       : WPA2-Personal
Cifrado             : CCMP
```

```
Estado de la red hospedada
```

```
-----
```

```
Estado                : Iniciado
BSSID                 : 6a:5d:43:2d:47:04
Tipo de radio         : 802.11n
Canal                  : 1
Número de clientes    : 1
e8:de:27:a2:c3:86     Autenticado
```

In this case the Raspberry Pi's MAC address is `e8:de:27:a2:c3:86`, showing that the OCAS is connected to the GCS via the ad-hoc network

## SSH CONNECTION WITH THE GCS

Assuming that the steps in Appendix A were successfully completed, this Appendix explains how to obtain the parameters needed to set up the SSH connection between the OCAS and the GCS.

1. Open a Command Prompt window as Administrator (network commands cannot be run by regular users for safety reasons)
2. Check that the Raspberry Pi's MAC address by showing the devices that are connected to the Windows' network:

```
> netsh wlan show hostednetwork

Configuración de red hospedada
-----
    Modo: permitido
    Nombre de SSID      : "quad_network"
    Nº máximo de clientes : 100
    Autenticación       : WPA2-Personal
    Cifrado              : CCMP

Estado de la red hospedada
-----
    Estado              : Iniciado
    BSSID               : 6a:5d:43:2d:47:04
    Tipo de radio       : 802.11n
    Canal               : 1
    Número de clientes  : 1
                       e8:de:27:a2:c3:86   Autenticado
```

In this case the Raspberry Pi's MAC address is e8:de:27:a2:c3:86

3. Match the MAC address to the assigned IP given by the DHCP server

```
> arp -a

Interfaz: 192.168.137.1 --- 0xb
Dirección de Internet      Dirección física      Tipo
192.168.137.76            e8-de-27-a2-c3-86    estático
192.168.137.255          ff-ff-ff-ff-ff-ff    estático
224.0.0.22                01-00-5e-00-00-16    estático
224.0.0.251              01-00-5e-00-00-fb    estático
224.0.0.252              01-00-5e-00-00-fc    estático
239.255.255.250          01-00-5e-7f-ff-fa    estático
255.255.255.255          ff-ff-ff-ff-ff-ff    estático
```

If the ARP cache is cluttered and the MAC address cannot be found, a flush might be helpful to clear unused entries:

```
netsh interface ip delete arpccache
```

In the example, the Raspberry Pi has been assigned the IP 192.167.137.76

4. To make use of the SSH protocol (being the 22<sup>nd</sup> port the one reserved for SSH communications) from a Windows machine, third party software is required.

PuTTY is the most common option for all types of network communication, but can be slightly limited for the operation of the OCAS

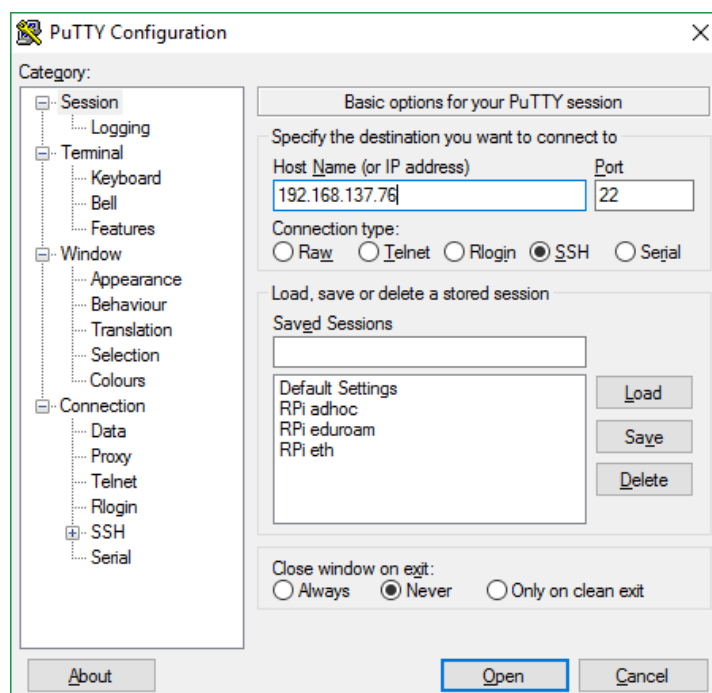

However, there exist more powerful alternatives to PuTTY, such as MobaXterm, which apart from SSH communications, can also handle X Window System forwarding; useful for the execution of graphical application directly on the Raspberry Pi, mirroring the interface on the Windows machine

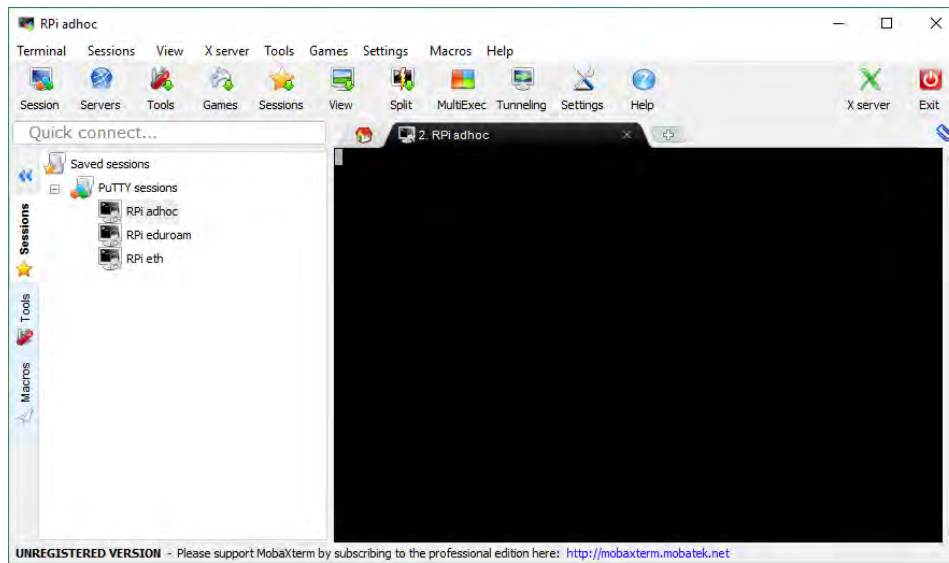

5. After connecting to the Raspberry Pi, user will be prompted to type the username and password. The default values are:
  - user: pi
  - password: raspberry
6. From this point the user will have complete access to the Linux system, in the same way as if they were operating directly from a terminal window



APPENDIX



**TECHNICAL DOCUMENTATION OF THE HC-SR04 RANGEFINDER**



## Ultrasonic Ranging Module HC - SR04

### Product features:

Ultrasonic ranging module HC - SR04 provides 2cm - 400cm non-contact measurement function, the ranging accuracy can reach to 3mm. The modules includes ultrasonic transmitters, receiver and control circuit. The basic principle of work:

- (1) Using IO trigger for at least 10us high level signal,
- (2) The Module automatically sends eight 40 kHz and detect whether there is a pulse signal back.
- (3) IF the signal back, through high level , time of high output IO duration is the time from sending ultrasonic to returning.

Test distance = (high level time×velocity of sound (340M/S) / 2,

### Wire connecting direct as following:

- 5V Supply
- Trigger Pulse Input
- Echo Pulse Output
- 0V Ground

### Electric Parameter

Working Voltage	DC 5 V
Working Current	15mA
Working Frequency	40Hz
Max Range	4m
Min Range	2cm
MeasuringAngle	15 degree
Trigger Input Signal	10uS TTL pulse
Echo Output Signal	Input TTL lever signal and the range in proportion
Dimension	45*20*15mm





## Timing diagram

The Timing diagram is shown below. You only need to supply a short 10uS pulse to the trigger input to start the ranging, and then the module will send out an 8 cycle burst of ultrasound at 40 kHz and raise its echo. The Echo is a distance object that is pulse width and the range in proportion. You can calculate the range through the time interval between sending trigger signal and receiving echo signal. Formula:  $\mu\text{S} / 58 = \text{centimeters}$  or  $\mu\text{S} / 148 = \text{inch}$ ; or: the range = high level time \* velocity (340M/S) / 2; we suggest to use over 60ms measurement cycle, in order to prevent trigger signal to the echo signal.

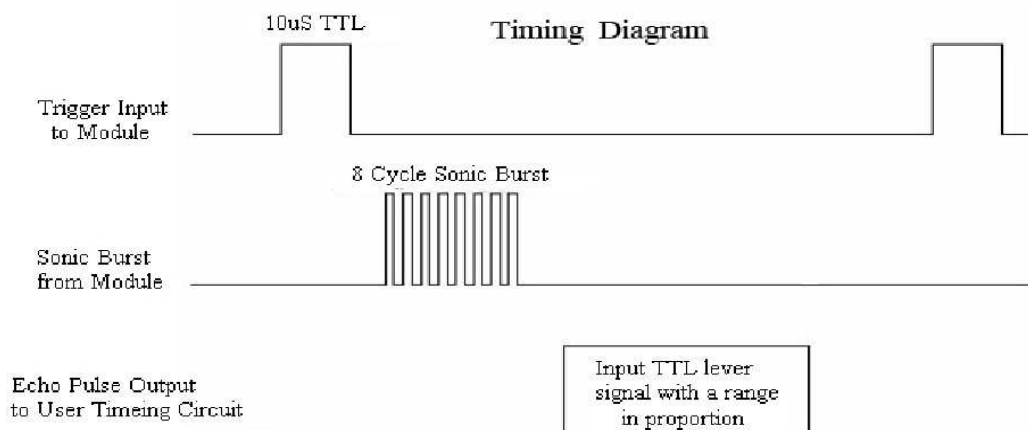

---

## **Attention:**

- The module is not suggested to connect directly to electric, if connected electric, the GND terminal should be connected the module first, otherwise, it will affect the normal work of the module.
- When tested objects, the range of area is not less than 0.5 square meters and the plane requests as smooth as possible, otherwise ,it will affect the results of measuring.

**[www.ElecFreaks.com](http://www.ElecFreaks.com)**





## THREADS.PY

```
1 import threading
2
3 class thrd(threading.Thread):
4
5     def __init__(self, fun,*args):
6         threading.Thread.__init__(self)
7         self.function=fun
8         if len(args)!=0:
9             self.arguments=args
10
11     def run(self):
12
13         try:
14             self.arguments
15         except:
16             self.function()
17         else:
18             self.function(*self.arguments)
```





## LOGGING SETUP

```
20 ## Set-up Logging ##
21 logFilename=os.path.dirname(os.path.realpath(__file__))+"/logs/"+str(time.strftime(
   "%Y%m%d-%H%M%S"))+".txt"
22
23 fid=open(logFilename,"w") # Open and then close to create a new file
24 fid.close()
25
26 logging.basicConfig(filename=logFilename,level=logging.DEBUG,format='%(asctime)s %(
   name)s:%(levelname)s %(message)s')
```





## CONNECT.PY

```
1 import dronekit
2
3 def Connect(mode="udp",address=["127.0.0.1",14550]):
4     """ Connects to the vehicle defined in the arguments and returns its class
5         Admissible modes: udp (default), serial or tcp """
6
7     if mode=="serial":
8         connection_string=address[0]
9         baudrate=str(address[1])
10    elif mode=="udp":
11        connection_string=str(address[0])+":"+str(address[1])
12    elif mode=="tcp":
13        connection_string="tcp:"+str(address[0])+":"+str(address[1])
14    else:
15        raise Exception('Connection mode has to be "serial", "udp" or "tcp"')
16
17
18    print "Connecting on: %s" % connection_string
19    if mode=="serial":
20        vehicle=dronekit.connect(ip=connection_string,wait_ready=True,rate=50,baud=
baudrate)
21    else:
22        vehicle=dronekit.connect(ip=connection_string,wait_ready=True,rate=50)
23
24    print "Vehicle connected"
25    return vehicle
```





APPENDIX



SONAR.PY

```
1 import RPi.GPIO as GPIO
2 import time
3 import signal
4 import numpy
5
6 from threads import thrd
7
8 class Sonar():
9
10     def __init__(self, trigPin, echoPin, bufferLen=5):
11
12         GPIO.setmode(GPIO.BCM)
13
14         self.echoPin=echoPin
15         self.trigPin=trigPin
16
17         GPIO.setup(self.trigPin,GPIO.OUT)
18         GPIO.setup(self.echoPin,GPIO.IN)
19
20         self.distance=100
21         self.distanceBuffer=[100]*bufferLen
22         self.avgDistance=100
23
24         self.velocity=1e-5
25         self.velocityBuffer=[1e-5]*bufferLen
26         self.avgVelocity=1e-5
27
28         self.initialTime=time.time()
29         self.timeArray=[time.time()-self.initialTime]*bufferLen
30
31         self.Tcollision=100
32         self.Treaction=0.5
33         self.Tstop=1
34         self.Tmargin=0.5
35         self.Tsafe=100
36
37     def __del__(self):
38         GPIO.cleanup()
39
40
41     def measureDistance(self):
42
43         time.sleep(0.05) # Wait a bit to avoid interference from previous measur
44         #ement
45
46         def triggerSonar():
47             GPIO.output(self.trigPin,False)
48             time.sleep(2e-6) # 2 microseconds
49             GPIO.output(self.trigPin,True)
50             time.sleep(1e-5) # 10 microseconds
51             GPIO.output(self.trigPin,False)
52             thrdTriggerSonar=thrd(triggerSonar)
53             thrdTriggerSonar.start()
54
55         # while GPIO.input(self.echoPin)==0: # Overwrite pulseStart until pulse is d
56         #     pulseStart=time.time()-self.initialTime
57         #     # Performing rolling average over the buffers to reduce noise-related e
58         #     rrors
59
60         # while GPIO.input(self.echoPin)==1: # Overwrite pulseEnd until pulse has en
61         #     ded
62         #     pulseEnd=time.time()-self.initialTime
```

```

60
61     GPIO.wait_for_edge(self.echoPin,GPIO.RISING,timeout=100)
62     pulseStart=time.time()-self.initialTime
63     GPIO.wait_for_edge(self.echoPin,GPIO.FALLING,timeout=100)
64     pulseEnd=time.time()-self.initialTime
65
66     try:
67
68         pulseDuration=pulseEnd-pulseStart
69
70         sonarDistance=(pulseDuration/2.0)*340
71
72         if sonarDistance<4: # Sensor not accurate for higher values
73             self.distance=sonarDistance
74
75             # Update buffer
76             for b in range(len(self.distanceBuffer)-1,0,-1): # Shift positio
n of the old values
77                 self.distanceBuffer[b]=self.distanceBuffer[b-1]
78                 self.distanceBuffer[0]=self.distance # Include latest measuremen
t
79
80             # Update filtered distance
81             self.avgDistance=numpy.mean(self.distanceBuffer)
82
83             # Update time array
84             for t in range(len(self.timeArray)-1,0,-1):
85                 self.timeArray[t]=self.timeArray[t-1]
86                 self.timeArray[0]=(pulseEnd+pulseStart)/2
87
88             return self.distance
89
90     except:
91         print "Error reading the distance. Trying again"
92
93
94     def computeVelocity(self):
95
96         try: # To avoid divisions by 0 from throwing an error
97
98             # Backward differences with a three-data-points stencil
99             self.velocity=(2*self.distanceBuffer[0]-self.distanceBuffer[1]-self.dis
tanceBuffer[2])/(2*self.timeArray[0]-self.timeArray[1]-self.timeArray[2])
100
101         except:
102             pass
103
104         else:
105             for v in range(len(self.velocityBuffer)-1,0,-1):
106                 self.velocityBuffer[v]=self.velocityBuffer[v-1]
107                 self.velocityBuffer[0]=self.velocity
108
109             self.avgVelocity=numpy.mean(self.velocityBuffer)
110
111             return self.avgVelocity
112
113
114     def calculateCollision(self):
115
116         self.Tcollision=self.avgDistance/self.avgVelocity
117         self.Tsafe=self.Tcollision-self.Treaction-self.Tstop-self.Tmargin
118
119         return self.Tsafe

```



A P P E N D I X



CONTROL.PY

```
1 import threading          # For thread events
2 from threads import thrd  # For other threads
3 import sound
4 import time
5
6 class Control:
7
8     def __init__(self, takeFun, checkTakeFun, giveFun, checkGiveFun, takeArgs=None, check
9     TakeArgs=None, giveArgs=None, checkGiveArgs=None):
10         self.takenFlag=threading.Event()    # Create event flag to allow input from
11         check() thread
12         self.takeFun=takeFun                # Function executed to take control
13         self.checkTakeFun=checkTakeFun     # Condition checked for control taken (Bool
14         ean function)
15         self.giveFun=giveFun                # Function executed to give control
16         self.checkGiveFun=checkGiveFun     # Condition checked for control give (Boole
17         an function)
18
19         if takeArgs!=None: self.takeArgs=takeArgs
20         if checkTakeArgs!=None: self.checkTakeArgs=checkTakeArgs
21         if giveArgs!=None: self.giveArgs=giveArgs
22         if checkGiveArgs!=None: self.checkGiveArgs=checkGiveArgs
23
24     def take(self):
25
26         def takeThrd():
27             while not self.takenFlag.isSet():
28                 try:
29                     self.takeArgs
30                 except:
31                     self.takeFun
32                 else:
33                     self.takeFun(self.takeArgs)
34             self.takenFlag.wait(5) # Lock thread until released via self.taken
35             Flag.set() in self.check() method or timed out
36
37         takeClass=thrd(takeThrd)
38         takeClass.name="takeClass"
39         takeClass.start()
40
41     def checkTake(self):
42
43         def checkTakeThrd():
44             while not self.takenFlag.isSet():
45                 try: # Call function either with or without arguments
46                     self.checkTakeArgs
47                 except:
48                     if self.checkTakeFun():
49                         time.sleep(0.1)
50                         sound.beep(1000,1000)
51                         self.takenFlag.set()
52                 else:
53                     if self.checkTakeFun(self.checkTakeArgs):
54                         time.sleep(0.1)
55                         sound.beep(1000,1000)
56                         self.takenFlag.set()
57
58         checkTakeClass=thrd(checkTakeThrd)
59         checkTakeClass.name="checkTakeClass"
60         checkTakeClass.start()
```

```
59
60     def give(self):
61
62         def giveThrd():
63             while self.takenFlag.isSet():
64                 try:
65                     self.giveArgs
66                 except:
67                     self.giveFun
68                 else:
69                     self.giveFun(self.giveArgs)
70             self.takenFlag.wait(0.02) # Lock thread until released via self.t
akenFlag.set() by self.check() method or timed out
71
72         giveClass=thrd(giveThrd)
73         giveClass.name="giveClass"
74         giveClass.start()
75
76
77     def checkGive(self):
78
79         def checkGiveThrd():
80             while self.takenFlag.isSet():
81                 try: # Call function either with or without arguments
82                     self.checkGiveArgs
83                 except:
84                     if self.checkGiveFun():
85                         self.takenFlag.clear()
86                 else:
87                     if self.checkGiveFun(self.checkGiveArgs):
88                         self.takenFlag.clear()
89
90         checkGiveClass=thrd(checkGiveThrd)
91         checkGiveClass.name="checkGiveClass"
92         checkGiveClass.start()
93
```





A P P E N D I X



AUTO.PY

```
1 import threading
2 from threads import thrd
3
4
5 class Auto:
6
7     def __init__(self,missionFun,stopFun,missionArgs=None,stopArgs=None):
8         self.stopAutoFlag=threading.Event() # For stopping the autonomous flight at
          any time
9
10        self.missionFun=missionFun
11        self.stopFun=stopFun
12
13        if missionArgs!=None: self.missionArgs=missionArgs
14        if stopArgs!=None: self.stopArgs=stopArgs
15
16
17    def fly(self):
18
19        def flyThrd():
20            while not self.stopAutoFlag.isSet():
21                try:
22                    self.missionArgs
23                except:
24                    self.missionFun
25                else:
26                    self.missionFun(self.missionArgs)
27
28        flyClass=thrd(flyThrd)
29        flyClass.name="flyClass"
30        flyClass.start()
31
32
33    def stop(self):
34
35        def stopThrd():
36            while not self.stopAutoFlag.isSet():
37                try:
38                    self.stopArgs
39                except:
40                    if self.stopFun: self.stopAutoFlag.set()
41                else:
42                    if self.stopFun(self.stopArgs): self.stopAutoFlag.set()
43
44        stopClass=thrd(stopThrd)
45        stopClass.name="stopClass"
46        stopClass.start()
47
48
49
50
51
52
```

APPENDIX



MAIN.PY

```
1  # Stock modules
2  import os
3  import sys
4  import logging
5  import time
6  import dronekit
7  import threading
8  import numpy
9  import math
10
11 # Custom modules
12 from connect import Connect # For connecting to the vehicle
13 from observe import Observe # For observing the state of the vehicle
14 from threads import thrd # For multithreading capabilities
15 import sound # For playing sounds on the background (without affecting main thread
16 )
17 import angle # For operations with angles (to avoid discontinuities)
18 from control import Control # For taking and giving control to the pilot, checking
19 if it was successful
20
21 from auto import Auto # For controlling autonomous flight
22 from sonar import Sonar # For sonar sensors operation
23
24 ## Set-up Logging ##
25 logFilename=os.path.dirname(os.path.realpath(__file__))+"/logs/"+str(time.strftime(
26 "%Y%m%d-%H%M%S"))+".txt"
27
28 fid=open(logFilename,"w") # Open and then close to create a new file
29 fid.close()
30
31 logging.basicConfig(filename=logFilename,level=logging.DEBUG,format='%(asctime)s %(
32 name)s:%(levelname)s %(message)s')
33
34
35 ##### Step 1: Connect to vehicle #####
36
37 logStr = "\nStart of script"
38 print logStr
39 logging.info(logStr)
40
41 vehicle = Connect()
42
43 logStr = "Vehicle connected"
44 print logStr
45 logging.info(logStr)
46
47 ##### Step 2: Observe state until "take control" condition is met #####
48
49 sonars=[Sonar(3,4),Sonar(14,15),Sonar(17,18)]
50
51 """
52 for c in range(10): # Measure several times to have data on velocity
53     for s in range(3):
54         sonars[s].measureDistance()
55         sonars[s].computeVelocity()
56 """
57
58 for c in range(10): # Pre-populate arrays
59     print ""
60
61     for s in range(3):
62         sonars[s].measureDistance()
63         sonars[s].computeVelocity()
64         sonars[s].calculateCollision()
```

```
60
61     logStr = "S%d>> Distance: %.3f [m] Velocity: %.2f [m/s] Tcollision: %.2f [
s] Tsafe: %.2f [s]" % (s,sonars[s].avgDistance,sonars[s].avgVelocity,sonars[s].Tco
llision,sonars[s].Tsafe)
62     print logStr
63     logging.info(logStr)
64
65
66     logStr = "Starting measurements"
67     print logStr
68     logging.info(logStr)
69
70     while not (sonars[s].Tsafe < 0 and sonars[s].Tcollision > 0):
71
72         for s in range(3):
73
74             sonars[s].measureDistance()
75             sonars[s].computeVelocity()
76             sonars[s].calculateCollision()
77
78             logStr = "S%d>> Distance: %.3f [m] Velocity: %.2f [m/s] Tcollision: %.2f [
s] Tsafe: %.2f [s]" % (s,sonars[s].avgDistance,sonars[s].avgVelocity,sonars[s].Tco
llision,sonars[s].Tsafe)
79             print logStr
80             logging.info(logStr)
81
82             logStr = ""
83             print logStr
84             logging.info(logStr)
85
86
87     logStr = "Condition met"
88     print logStr
89     logging.info(logStr)
90
91     sound.beep(440, 200)
92
93
94     #### Step 3: Take control ####
95
96     def changeMode(mode):
97         vehicle.mode = dronekit.VehicleMode(mode)
98
99
100    def checkMode(mode):
101        return vehicle.mode.name==mode
102
103
104    ctrl = Control(takeFun=changeMode, checkTakeFun=checkMode, giveFun=changeMode, chec
kGiveFun=checkMode,
105                  takeArgs="GUIDED", checkTakeArgs="GUIDED", giveArgs="LOITER", checkG
iveArgs="LOITER")
106
107    logStr = "Taking control"
108    print logStr
109    logging.info(logStr)
110
111    ctrl.take()
112    ctrl.checkTake()
113
114    while not threading.activeCount() <= 3:
115        time.sleep(0.02)
116
```

```

117 logStr = "Control taken"
118 print logStr
119 logging.info(logStr)
120
121
122 ##### Step 4: Autonomous flight #####
123
124 def do_move(distance,tMove,direction=[1,0,0]):
125
126     # def goto_position_target_Local_ned(north, east, down):
127     #     """
128     #     Send SET_POSITION_TARGET_LOCAL_NED command to request the vehicle fly to a
specified
129     #     location in the North, East, Down frame.
130
131     #     It is important to remember that in this frame, positive altitudes are ente
red as negative
132     #     "Down" values. So if down is "10", this will be 10 metres below the home al
titude.
133
134     #     At time of writing, acceleration and yaw bits are ignored.
135
136     #     """
137     #     msg = vehicle.message_factory.set_position_target_Local_ned_encode(
138     #         0,          # time_boot_ms (not used)
139     #         0, 0,      # target system, target component
140     #         mavutil.mavlink.MAV_FRAME_LOCAL_NED, # frame
141     #         0b000011111111000, # type_mask (only positions enabled)
142     #         north, east, down, # x, y, z positions (or North, East, Down in the MAV
_FRAME_BODY_NED frame
143     #         0, 0, 0, # x, y, z velocity in m/s (not used)
144     #         0, 0, 0, # x, y, z acceleration (not supported yet, ignored in GCS_MavL
ink)
145     #         0, 0)    # yaw, yaw_rate (not supported yet, ignored in GCS_MavLink)
146     #     # send command to vehicle
147     #     vehicle.send_mavlink(msg)
148
149
150     def body2ned(frontBody,leftBody,upBody=-vehicle.location.global_relative_frame.
alt):
151
152         yaw=vehicle.attitude.yaw
153         yawCorrected=yaw+40/180/math.pi # Weird offset. Don't know why, but it work
s
154         north=frontBody*math.cos(yawCorrected)+leftBody*math.sin(yawCorrected)
155         east=frontBody*math.sin(yawCorrected)-leftBody*math.cos(yawCorrected)
156         down=-upBody
157         return [north,east,down]
158
159     def ned2global(original_location, dNorth, dEast, dDown=0):
160     """
161     Returns a LocationGlobal object containing the latitude/longitude `dNorth`
and `dEast` metres from the
162     specified `original_location`. The returned LocationGlobal has the same `al
t` value
163     as `original_location`.
164
165     The function is useful when you want to move the vehicle around specifying
locations relative to
166     the current vehicle position.
167
168     The algorithm is relatively accurate over small distances (10m within 1km)
except close to the poles.

```

```
169
170     For more information see:
171     http://gis.stackexchange.com/questions/2951/algorithm-for-offsetting-a-lati
172     tude-longitude-by-some-amount-of-meters
173     """
174     earth_radius=6378137.0 #Radius of "spherical" earth
175     #Coordinate offsets in radians
176     dLat = dNorth/earth_radius
177     dLon = dEast/(earth_radius*math.cos(math.pi*original_location.lat/180))
178     dAlt = -dDown
179
180     #New position in decimal degrees
181     newlat = original_location.lat + (dLat * 180/math.pi)
182     newlon = original_location.lon + (dLon * 180/math.pi)
183     newalt = original_location.alt + dAlt
184     if type(original_location) is dronekit.LocationGlobal:
185         targetlocation=dronekit.LocationGlobal(newlat, newlon, newalt)
186     elif type(original_location) is dronekit.LocationGlobalRelative:
187         targetlocation=dronekit.LocationGlobalRelative(newlat, newlon, dAlt)
188     else:
189         raise Exception("Invalid Location object passed")
190
191     return targetlocation;
192
193     vehicle.simple_goto(ned2global(vehicle.location.global_frame,body2ned(distance*
194     direction[0],distance*direction[1],distance*direction[2])[0],body2ned(distance*direc
195     ction[0],distance*direction[1],distance*direction[2])[1],body2ned(distance*directio
196     n[0],distance*direction[1],distance*direction[2])[2]))
197     # goto_position_target_Local_ned(*body2ned(distance*direction[0],distance*direc
198     tion[1],distance*direction[2]))
199     print "Moving"
200
201     time.sleep(tMove+1)
202
203     def wait(seconds):
204         time.sleep(seconds)
205         return True
206
207     autoMove = Auto(do_move, wait, [3,10,[0,0,1]], 10)
208
209     print "Starting autonomous flight"
210     autoMove.fly()
211     autoMove.stop()
212
213     while not threading.activeCount() <= 3:
214         time.sleep(0.02)
215     print "Mission finished"
216
217     ##### Step 5: Return control to the pilot #####
218
219     logStr = "Returning control"
220     print logStr
221     logging.info(logStr)
222
223     # Recovering ctrl class instance that was created in step 3
224     ctrl.give()
225     ctrl.checkGive()
226
```

```
227 while not threading.activeCount() <= 3:
228     time.sleep(0.02)
229
230 logStr = "Control returned"
231 print logStr
232 logging.info(logStr)
233
234 sound.tripleBeep(700, 150, 600, 150, 500, 300)
235
236 logStr = "\nTerminating script\n"
237 print logStr
238 logging.info(logStr)
239 vehicle.close()
240
241
```



## TEMPERATURE SENSITIVITY OF ULTRASONIC RANGEFINDERS

The ultrasonic rangefinders rely on an accurate definition of the speed of propagation of sound in air in order to compute the distance to the closest detected object. However, the speed of sound depends on the temperature of the medium, which could be fluctuating along the duration of the mission.

In the present appendix it will be proven that reasonable temperature fluctuations actually have a negligible effect on the distance measurements within the scope of the ultrasonic rangefinders.

The speed of propagation of a sound wave in an ideal gaseous medium obeys the equation

$$(K.1) \quad a = \sqrt{\gamma R_g T}$$

where  $\gamma = 1.4$  is the adiabatic coefficient and  $R_g = 287 \frac{J}{kg \cdot K}$  is the specific gas constant of air.

For the variation of  $a$  with temperature:

$$(K.2) \quad \frac{da}{dT} = \sqrt{\gamma R_g} \cdot \frac{1}{2\sqrt{T}}$$

Considering that the speed of sound at room temperature is  $a_{298K} = 340m/s$ , the speed of sound gradient is:

$$(K.3) \quad \left. \frac{da}{dT} \right|_{298K} = 0.581 \frac{m/s}{K}$$

Assuming measurements of the order of 1 metre, the order of times being dealt with is:

$$(K.4) \quad x = \Delta t \cdot a(T) \sim 1m \Rightarrow \Delta t \sim 2.9 \times 10^{-3}s$$

Finally, differentiating equation (K.4) with respect to temperature gives:

$$(K.5) \quad \left. \frac{dx}{dT} \right|_{T=298K} = \Delta t \cdot \left. \frac{da}{dT} \right|_{T=298K} \sim 1.7 \times 10^{-3}m$$

So, for an extreme temperature departure of 10 K from the calibrated standard speed of sound, the resulting distance error would be in the order of the millimetre, which lies within the accuracy levels of the sensor itself, making the measurement errors due to temperature change effectively negligible.

APPENDIX



GUI.PYW

```
1 import Tkinter
2 import ttk
3 import subprocess
4
5
6 window = Tkinter.Tk()
7 window.title("DroneKit Launcher")
8 try:
9     window.iconbitmap('C:\\Users\\Usuario\\Documents\\GitHub\\quadcopters-tfg-lvaro
\\Dronekit\\favicon.ico')
10 except:
11     pass
12 window.resizable(0,0)
13
14 mainFrame=Tkinter.LabelFrame(window,relief=Tkinter.RIDGE)
15 mainFrame.grid(sticky=Tkinter.NS)
16
17 ##### PLATFORM #####
18
19
20 platform=Tkinter.LabelFrame(mainFrame,text="Platform")
21 platform.grid(row=0,rowspan=2,column=0,padx=5,pady=5,ipadx=5,ipady=5,sticky=Tkinter
.NS)
22
23
24 def changeSelection(*args):
25     if str(platformValue.get())=="SITL":
26         platformSITLlaunch.configure(state=Tkinter.NORMAL)
27         mvyPortText.configure(text="Port")
28         mvyAddress.set("tcp:127.0.0.1")
29         mvyPort.set("5760")
30     elif str(platformValue.get())=="UAV":
31         platformSITLlaunch.configure(state=Tkinter.DISABLED)
32         mvyPortText.configure(text="Baud rate")
33         if str(platformUAVselect.get())=="USB":
34             mvyAddress.set("com6")
35             mvyPort.set("115200")
36         elif str(platformUAVselect.get())=="Telemetry":
37             mvyAddress.set("com4")
38             mvyPort.set("57600")
39         else:
40             mvyAddress.set("")
41             mvyPort.set("")
42
43 def launchSITL():
44     openCMD= 'START CMD /K '
45     sitlRoute='C:\\Users\\Usuario\\Google Drive\\TFG Alvaro Melgosa Pascual\\WinPy
thon-64bit-2.7.10.3\\python-2.7.10.amd64\\Scripts\\dronekit-sitl.exe'
46     sitlArgs='copter-v3.2.1 --model x --home=40.333266, -3.765728,620,0'
47     subprocess.call(openCMD + sitlRoute + sitlArgs, shell=True)
48
49
50 platformValue=Tkinter.StringVar()
51
52 platformSITL=Tkinter.Radiobutton(platform,text="SITL",variable=platformValue,value=
"SITL",command=changeSelection)
53 platformSITL.grid(row=0,column=0,padx=5,pady=5)
54
55 platformSITLlaunch=Tkinter.Button(platform,text="Launch",command=launchSITL,width=8
)
56 platformSITLlaunch.grid(row=0,column=1,padx=5,pady=5)
57
58 platformUAV=Tkinter.Radiobutton(platform,text="UAV",variable=platformValue,value="U
```

```
AV",command=changeSelection)
59 platformUAV.grid(row=1,column=0,padx=5,pady=5)
60
61 platformUAVconnect=Tkinter.StringVar()
62 platformUAVselect=ttk.Combobox(platform,width=7,textvariable=platformUAVconnect)
63 platformUAVselect['values']=("USB","Telemetry")
64 platformUAVselect.bind("<<ComboboxSelected>>",changeSelection)
65 platformUAVselect.grid(row=1,column=1,padx=5,pady=5)
66
67
68 ##### MAVPROXY #####
69
70 mvpvpy=Tkinter.LabelFrame(mainFrame,text="MAVProxy",relief=Tkinter.GROOVE)
71 mvpvpy.grid(row=0,rowspan=2,column=1,padx=5,pady=5,ipadx=5,ipady=5,sticky=Tkinter.NS)
72
73
74 def launchMavproxy(address,port):
75     openCMD='START CMD /K '
76     mavproxyRoute='"C:\\Users\\Usuario\\Google Drive\\TFG Alvaro Melgosa Pascual\\M
AVProxy\\mavproxy.exe" '
77     if address[0:3]=="com":
78         mavproxyArgs=' --master=' + address + ' --baud=' + port + ' --out=127.0.0.1
:14550 --out=127.0.0.1:14551'
79     else:
80         mavproxyArgs=' --master=' + address + ':' + port + ' --out=127.0.0.1:14550
--out=127.0.0.1:14551'
81     subprocess.call(openCMD + mavproxyRoute + mavproxyArgs, shell=True)
82
83 mvpvpyAddressText=Tkinter.Label(mvpvpy,text="Address")
84 mvpvpyAddressText.grid(row=0,column=0,padx=5,pady=5,sticky=Tkinter.E)
85
86 mvpvpyAddress=Tkinter.StringVar()
87 mvpvpyAddressValue=Tkinter.Entry(mvpvpy,textvariable=mvpvpyAddress,width=12)
88 mvpvpyAddressValue.grid(row=0,column=1,padx=5,pady=5)
89
90 mvpvpyPortText=Tkinter.Label(mvpvpy,text="Baud rate")
91 mvpvpyPortText.grid(row=1,column=0,padx=5,pady=5,sticky=Tkinter.E)
92
93 mvpvpyPort=Tkinter.StringVar()
94 mvpvpyPortValue=Tkinter.Entry(mvpvpy,textvariable=mvpvpyPort,width=12)
95 mvpvpyPortValue.grid(row=1,column=1,padx=5,pady=5)
96
97 mvpvpyConnect=Tkinter.Button(mvpvpy,text="Connect",command=lambda:launchMavproxy(str(mv
pvpyAddress.get()),str(mvpvpyPort.get())))
98 mvpvpyConnect.grid(row=2,column=1,padx=5,pady=5,sticky=Tkinter.E)
99
100
101 ##### SCRIPT #####
102
103 script=Tkinter.LabelFrame(mainFrame,text="Script",relief=Tkinter.GROOVE)
104 script.grid(row=0,column=2,padx=5,pady=5,ipadx=5,ipady=5)
105
106 def runScript(route):
107     openCMD='START CMD /K '
108     scriptRoute='"C:\\Users\\Usuario\\Documents\\GitHub\\quadcopters-tfg-lvaro\\Dro
nekit\\' + route + '\\main.py"'
109     subprocess.call(openCMD + scriptRoute, shell=True)
110
111 scriptLabel=Tkinter.Label(script,text="File location")
112 scriptLabel.grid(row=0,column=0,padx=5,pady=5)
113
114 scriptFileLocation=Tkinter.StringVar()
115 scriptFile=Tkinter.Entry(script,textvariable=scriptFileLocation,width=15)
```

```
116 scriptFile.grid(row=1,column=0,padx=5)
117
118 scriptRun=Tkinter.Button(script,text="Run script",command=lambda:runScript(str(scri
ptFileLocation.get())))
119 scriptRun.grid(row=1,column=1,padx=5,pady=5)
120
121
122 ##### MISSION PLANNER #####
123
124 def launchPlanner():
125     openCMD='START CMD /K '
126     plannerRoute='"C:\\Program Files (x86)\\Mission Planner\\MissionPlanner.exe"'
127     subprocess.call(openCMD + plannerRoute, shell=True)
128
129 planner=Tkinter.Button(mainFrame,text="Launch Mission Planner",command=launchPlanne
r)
130 planner.grid(column=2,row=1,padx=5,pady=5)
131
132
133
134
135 window.mainloop()
136
137
```



## RASPBERRY PI'S INTERFACES CONFIGURATION

### **/etc/network/interfaces**

```
1 auto lo
2 iface lo inet loopback
3
4 auto eth0
5 allow-hotplug eth0
6
7 iface eth0 inet static
8 address 169.254.190.99
9 netmask 255.255.0.0
10 gateway 169.254.255.255
11
12 auto wlan0
13 iface wlan0 inet manual
14 wpa-conf /etc/wpa_supplicant/wpa_supplicant.conf
15
16 auto wlan1
17 iface wlan1 inet manual
18 wpa-conf /etc/wpa_supplicant/wpa_supplicant.conf
19
```

### **/etc/wpa\_supplicant/wpa\_supplicant.conf**

```
1 ctrl_interface=DIR=/var/run/wpa_supplicant GROUP=netdev
2 update_config=1
3
4 network={
5     ssid="quad_network"
6     psk="*****"
7     proto=RSN
8     key_mgmt=WPA-PSK
9     pairwise=CCMP
10    auth_alg=OPEN
11    priority=100
12 }
```





APPENDIX



SONARDRIVER.PY

```
1  from sonar import Sonar
2  from threads import thrd
3
4  import time
5  import threading
6  import matplotlib.pyplot as plt
7  import numpy as np
8
9  #sonar1=Sonar(3,4)
10 #sonar2=Sonar(14,15)
11 #sonar3=Sonar(17,18)
12 sonars=[Sonar(3,4),Sonar(14,15),Sonar(17,18)]
13
14 plt.figure("distance")
15 #plt.figure("velocity")
16 plt.ion()
17 plt.show()
18 plt.hold(False)
19
20 t=np.arange(-len(sonars[0].timeArray),0,1)
21 dist=np.zeros((3,len(sonars[0].distanceBuffer)))
22 vel=np.zeros((3,len(sonars[0].velocityBuffer)))
23
24 for c in range(5): # Pre-populate buffers
25     for s in range(3):
26         sonars[s].measureDistance()
27         sonars[s].computeVelocity()
28
29 while True:
30
31     for s in range(3):
32         sonars[s].measureDistance()
33         sonars[s].computeVelocity()
34
35     print "%.3fs> Sonar 0: %s [m]    %s [m/s]" % (sonars[0].timeArray[0],sonars[0].d
istance, sonars[0].velocity)
36     print "%.3fs> Sonar 1: %s [m]    %s [m/s]" % (sonars[1].timeArray[0],sonars[1].d
istance, sonars[1].velocity)
37     print "%.3fs> Sonar 2: %s [m]    %s [m/s]" % (sonars[2].timeArray[0],sonars[2].d
istance, sonars[2].velocity)
38     print ""
39
40
41     plt.figure("distance")
42     plt.plot(sonars[0].timeArray,sonars[0].distanceBuffer,sonars[1].timeArray,sonar
s[1].distanceBuffer,sonars[2].timeArray,sonars[2].distanceBuffer)
43     plt.axis([min(min(sonars[0].timeArray),min(sonars[1].timeArray),min(sonars[2].t
imeArray)),max(max(sonars[0].timeArray),max(sonars[1].timeArray),max(sonars[2].time
Array)),0,4])
44     plt.legend(["Sonar 0", "Sonar 1", "Sonar 2"])
45
46     plt.figure("velocity")
47     plt.plot(sonars[0].timeArray,sonars[0].velocityBuffer,sonars[1].timeArray,sonar
s[1].velocityBuffer,sonars[2].timeArray,sonars[2].velocityBuffer)
48     plt.axis([min(min(sonars[0].timeArray),min(sonars[1].timeArray),min(sonars[2].t
imeArray)),max(max(sonars[0].timeArray),max(sonars[1].timeArray),max(sonars[2].time
Array)),-1,1])
49     plt.legend(["Sonar 0", "Sonar 1", "Sonar 2"])
50
51     plt.pause(1e-6)
52
```



## CHANNEL 7 SCRIPT TRIGGER

```
22 ##### Step 2: Observe state until "take control" condition is met #####
23
24 ch7obs=observe(vehicle.channels["7"], 2001)
25 print "Waiting for condition to be met"
26
27 ch7obs.update(vehicle.channels["7"])
28 while not ch7obs.geq(ch7obs.value-200): # 200 PWM tolerance
29     timeLoop = time.clock()
30     while (time.clock()-timeLoop) < 0.2:
31         pass # Do not continue until there is new data to update
32     ch7obs.update(vehicle.channels["7"])
33     print "CH7 current value: %i    CH7 target: %i" % (ch7obs.variable, ch7obs.value
34 )
35 print "Condition met"
36 sound.beep(440, 200)
```



APPENDIX



**OBSERVE.PY**

```

1  class Observe:
2      """
3      The Observe class stores two values:
4      self.value      is the target value on a certain state variable of the observed system
5      self.variable   is the actual (probably changing) value of that state variable
6
7      self.value and self.variable can be set at instance initialization, or with the self.update() method
8      Additionally, there exist some methods that allow for easy comparison of self.variable vs self.value:
9
10     Method      | .equ() .neq() .gtr() .geq() .lss() .leq() |
11     Equivalent  | ==     !=     >     >=    <     <=    |
12     With these methods self.value will not be updated
13     """
14
15     def __init__(self,*args):
16         if len(args)==0:
17             self.initial=None
18             self.value=None
19             self.variable=None
20         elif len(args)==1:
21             self.initial=args[0]
22             self.value=None
23             self.variable=None
24         elif len(args)==2:
25             self.initial=args[0]
26             self.value=args[1]
27             self.variable=None
28         elif len(args)==3:
29             self.initial=args[0]
30             self.value=args[1]
31             self.variable=args[2]
32
33     def update(self,var,*args):
34         self.variable=var
35         if len(args)>0:
36             self.value=args[0]
37
38     def equ(self,*args):
39         if len(args)==1:      # If argument inserted, compare against it instead of using self.value
40             if self.variable==args[0]:
41                 return True
42             else:
43                 return False
44         else:
45             if self.variable==self.value:
46                 return True
47             else:
48                 return False
49
50     def neq(self,*args):
51         if len(args)==1:      # If argument inserted, compare against it instead of using self.value
52             if self.variable!=args[0]:
53                 return True
54             else:
55                 return False
56         else:
57             if self.variable!=self.value:
58                 return True
59             else:
60                 return False

```

```
58         return False
59     def gtr(self,*args):
60         if len(args)==1: # If argument inserted, compare against it instead of u
sing self.value
61             if self.variable>args[0]:
62                 return True
63             else:
64                 return False
65         else:
66             if self.variable>self.value:
67                 return True
68             else:
69                 return False
70     def geq(self,*args):
71         if len(args)==1: # If argument inserted, compare against it instead of u
sing self.value
72             if self.variable>=args[0]:
73                 return True
74             else:
75                 return False
76         else:
77             if self.variable>=self.value:
78                 return True
79             else:
80                 return False
81     def lss(self,*args):
82         if len(args)==1: # If argument inserted, compare against it instead of u
sing self.value
83             if self.variable<args[0]:
84                 return True
85             else:
86                 return False
87         else:
88             if self.variable<self.value:
89                 return True
90             else:
91                 return False
92     def leq(self,*args):
93         if len(args)==1: # If argument inserted, compare against it instead of u
sing self.value
94             if self.variable<=args[0]:
95                 return True
96             else:
97                 return False
98         else:
99             if self.variable<=self.value:
100                 return True
101             else:
102                 return False
```





## BIBLIOGRAPHY

- [1] National Aeronautics and Space Administration. *NASA systems engineering handbook*. 1st ed. Washington: US National Aeronautics and Space Admin, Dec. 2007. Chap. 4 (cit. on pp. 5, 23).
- [2] AESA. *Ley 18/2014, de 15 de octubre, de aprobacion de medidas urgentes para el crecimiento, la competitividad y la eficiencia*. Art. 50, Sec. 3. AESA, Oct. 15, 2014 (cit. on p. 3).
- [3] Gemma Aguado, Álvaro Melgosa, Alberto de Miguel, Álvaro Ordax, Jesús Perales, Jorge Luis Sáez, and Lara Cristina Sánchez. “UAV application in Search & Rescue at sea”. UC3M, May 2016 (cit. on p. 2).
- [4] Airbus. *Airbus demonstrates aircraft inspection by drone at Farnborough*. July 2016. URL: <http://www.airbus.com/presscentre/pressreleases/press-release-detail/detail/airbus-demonstrates-aircraft-inspection-by-drone-at-farnborough-innovation-and-digitalisation-for-production-ramp-up/> (visited on 08/01/2016) (cit. on p. 2).
- [5] Unmanned aerial vehicle systems association applications. *UAS Applications*. 2016. URL: <http://www.uavs.org/applications> (visited on 08/01/2016) (cit. on p. 1).
- [6] Richard Asselin. “Frequency Filter for Time Integrations”. In: *Monthly Weather Review* (June 1972), pp. 487–490 (cit. on p. 51).
- [7] Aerospace Industries Association. *Unmanned Aircraft Systems: Perceptions and Potentials*. Tech. rep. Arlington, May 2013. URL: [http://www.aia-aerospace.org/assets/AIA\\\_UAS\\\_Report\\\_small.pdf](http://www.aia-aerospace.org/assets/AIA\_UAS\_Report\_small.pdf) (visited on 2016) (cit. on p. 4).
- [8] Rubén Vega Astorga. “Simulation of an Unmanned Aerial Vehicle”. BSc Thesis. Leganés, Madrid: Universidad Carlos III de Madrid, June 2016 (cit. on pp. 46, 61).
- [9] Dana H. Ballard and Christopher M. Brown. *Computer vision*. New Jersey: Prentice Hall, 1982. Chap. 2.2 (cit. on pp. 11, 12).
- [10] Richard Beasley. *Systems Engineering - What and why?* Magistral lecture. University of Bristol, Feb. 2015 (cit. on p. 23).

## BIBLIOGRAPHY

---

- [11] Pia Bergqvist. *Drone Jobs: What It Takes to Fly a UAV*. June 2014. URL: <http://www.flyingmag.com/aircraft/drone-jobs-what-it-takes-fly-uav> (visited on 08/02/2016) (cit. on p. 4).
- [12] Jim Daily. *Dull, dirty, dangerous - it's robot work*. GE Digital. Feb. 19, 2015. URL: <https://www.ge.com/digital/blog/dull-dirty-dangerous-its-robot-work> (visited on 08/01/2016) (cit. on p. 1).
- [13] *Dronecode*. Apr. 28, 2016. URL: <https://www.dronecode.org/> (visited on 08/03/2016) (cit. on p. 15).
- [14] EASA. *Regulation (EC) No 216/2008*. Annex II, p. 79/33. EASA, Feb. 20, 2008. URL: <http://eur-lex.europa.eu/LexUriServ/LexUriServ.do?uri=OJ:L:2008:079:0001:0049:EN:PDF> (cit. on p. 3).
- [15] Gobierno de España. *Disposición 16097 de BOE núm. 274 de 2011*. BOE-A-2011-16097. Art. 23 & 33. Ministerio de la Presidencia, Oct. 13, 2011. URL: <http://www.boe.es/boe/dias/2011/10/13/pdfs/BOE-A-2011-16097.pdf> (visited on 08/02/2016) (cit. on p. 5).
- [16] R. Ian Faulconbridge and Michael J. Ryan. *Managing Complex Technical Projects: A Systems Engineering Approach*. Norwood, MA, USA: Artech House, 2003. Chap. 4.3.2, pp. 100–103 (cit. on p. 31).
- [17] Maite Arteta Fernández. “Assembly, modeling, simulation and control of a quadcopter for application to solar farm inspection”. BSc Thesis. Leganés, Madrid: Universidad Carlos III de Madrid, Sept. 2015 (cit. on pp. 7, 35, 40).
- [18] Bloomberg Government. *Civilian Unmanned Aerial Vehicles Ready For Takeoff*. Tech. rep. Apr. 2012 (cit. on p. 4).
- [19] Christian Hulsmeier. “Verfahren, um entfrente metallische Gegenstände mittels elektrischer Wellen einem Beobachter zu meiden”. Pat. Apr. 1904. URL: <https://commons.wikimedia.org/wiki/File:DE165546.pdf> (visited on 08/05/2016) (cit. on p. 9).
- [20] ICAO. *Manual on remotely piloted aircraft systems (RPAS)*. Ed. by ICAO. 1st ed. International Civil Aviation Organization. Montréal, Canada, 2015 (cit. on p. 3).
- [21] INCOSE. *What is systems engineering?* URL: <http://www.incose.org/AboutSE/WhatIsSE> (visited on 08/02/2016) (cit. on p. 5).
- [22] Drone Industry Insights. *TOP20 Drone Company Ranking Q2 2016*. Tech. rep. Hamburg, Germany, June 2016. URL: <http://www.droneii.com/project/drone-company-ranking-q2-2016> (visited on 2016) (cit. on p. 15).
- [23] Jeffrey Krolik. *Radar and Sonar Signal Processing: Similarities and Differences*. May 2005. URL: [http://people.ee.duke.edu/~jk/SAM%20Group\\_files/radarsonarcompare.pdf](http://people.ee.duke.edu/~jk/SAM%20Group_files/radarsonarcompare.pdf) (visited on 08/06/2016) (cit. on p. 10).

- [24] Katsuhiko Ogata. *Modern Control Engineering*. 5th ed. Prentice Hall, 2010. Chap. 8 (cit. on p. 16).
- [25] Kevin N. Otto and Erik K. Antonsson. “Trade-off Strategies in Engineering Design”. In: *Research in Engineering Design*. Vol. 3. 2. 1991. Chap. 2, pp. 87–104 (cit. on p. 37).
- [26] Assistant Secretary of Defense for Research and Engineering. *Technology Readiness Assessment (TRA) Guidance*. Tech. rep. USA, Apr. 2011, 2–13 and 2–14 (cit. on pp. 9, 11).
- [27] J.Z. Sasiadek, Q. Wang, and M.B. Zeremba. “Fuzzy adaptive Kalman filtering for INS/GPS data fusion”. In: *Intelligent Control, 2000. Proceedings of the 2000 IEEE International Symposium*. 2000, pp. 181–186. URL: <http://ieeexplore.ieee.org/document/882920> (visited on 08/27/2016) (cit. on p. 51).
- [28] Mike Tooley and David Wyatt. *Aerospace engineering e-mega reference*. Ed. by Elsevier. 1st ed. United Kingdom: Butterworth-Heinemann, Mar. 2, 2009 (cit. on p. 12).
- [29] INCOSE UK. *Why invest in Systems Engineering*. July 2016. URL: [http://incoseonline.org.uk/Documents/zGuides/Z3\\_Why\\_invest\\_in\\_SE.pdf](http://incoseonline.org.uk/Documents/zGuides/Z3_Why_invest_in_SE.pdf) (visited on 09/14/2016) (cit. on p. 23).
- [30] Kimon P. Valavanis and George J. Vachtsevanos. *Handbook of Unmanned Aerial Vehicles*. New York: Springer Reference, 2015. Chap. 75, pp. 1817–1841 (cit. on p. 3).
- [31] Adam Wisniewski and Michal Mazur. *Clarity from above PwC global report on the commercial applications of drone technology*. Tech. rep. May 2016. URL: <http://www.pwc.pl/pl/pdf/clarity-from-above-pwc.pdf> (visited on 08/01/2016) (cit. on p. 2).