

This is a postprint version of the following published document:
Petrakopoulou, F., Robinson, A., Loizidoua, M. (2016). Exergetic
analysis and dynamic simulation of a solar-wind power plant
with electricity storage and hydrogen generation. *Journal of
Cleaner Production*, 113, p.450-458.

DOI: [10.1016/j.jclepro.2015.11.074](https://doi.org/10.1016/j.jclepro.2015.11.074)

© 2015 Elsevier Ltd. All rights reserved.



This work is licensed under a [Creative Commons Attribution-NonCommercial-NoDerivatives 4.0 International License](https://creativecommons.org/licenses/by-nc-nd/4.0/).

Exergetic analysis and dynamic simulation of a solar-wind power plant with electricity storage and hydrogen generation

Fontina Petrakopoulou^{1,1,2}, Alexander Robinson^{3,4}, Maria Loizidou¹

¹ *Unit of Environmental Science and Technology, National Technical University of Athens, 15773 Athens, Greece.*

² *Department of Thermal and Fluid Engineering, Universidad Carlos III de Madrid, Avda. de la Universidad 30, 28911 Leganés (Madrid), Spain.*

³ *Department of Astrophysics and Atmospheric Sciences, Universidad Complutense de Madrid, 28040 Madrid, Spain.*

⁴ *Instituto de Geociencias, UCM-CSIC, 28040 Madrid, Spain.*

Abstract

The ambitious vision of off-grid renewable energy autonomy of remote regions has yet to come to fruition. The development of comprehensive energy production systems would be needed to achieve such a goal. This study consists of the simulation and exergetic evaluation of a novel hybrid power plant for stand-alone operation aiming to provide electricity autonomy of a Mediterranean island. The considered power plant is simulated dynamically over an annual cycle and accounts for both energy input fluctuations and electricity surplus. The plant combines a photovoltaic array with wind turbines for energy input, coupled with electricity storage and a hydrogen generation facility for stable output. Unlike other similar studies, the energy system presented here relies on real-case weather and demand data of a relatively large remote community and is optimized to ensure continuous operation – even under extreme conditions. It is seen that this stand-alone hybrid power plant constitutes a robust and secure alternative to the current conventional energy situation; the combined renewable technologies succeed in complementing each other and offer stable performance throughout the year

without the requirement of additional support by fossil fuels. The mean annual exergetic efficiency of the plant is found to be 17.9 %, producing approximately 25,000 MWh of electricity per year, along with a secondary product (hydrogen) produced in the electrolyzer of the plant. Although this additional product is associated with additional investment cost, it offers the possibility to stabilize the power plant's performance and can be used as an additional source of financial input to the community.

Keywords: Hybrid power plant; energy storage; photovoltaic; wind; hydrogen; off-grid operation.

Introduction

An ever-increasing world population and industrialization in developing countries continuously raise global energy needs. Without significant change in present energy practices, greenhouse gas emissions related to energy use will continue to increase, stressing the climate to extreme and, until today, unknown conditions (IPCC, 2007). The European Union has committed to reducing anthropogenic greenhouse gas emissions from the combustion of fossil fuels by implementing energy-saving measures (UNFCCC, 2008). Measures proposed to reduce man-made emissions include reducing energy demand, increasing the efficiency of energy conversion and/or energy utilization, switching to less carbon-intensive fuels, increasing the use of renewable energy resources and nuclear energy and utilizing carbon capture and storage (IPCC, 2005). While none of these measures can directly solve the energy problem on its own, their appropriate combination can help us achieve a more sustainable living.

In recent years various efforts towards energy self-sufficiency with renewable technologies have been documented and ever more examples of regions that have managed to achieve or orientate themselves towards that goal are arising (EuropeanCommision, 2014; The republic of Lithuania, 2012). Several regions in Germany, Güssing in Austria, Varese in Italy, Thisted in Denmark, the island of Samsøe in Denmark, Kristianstad in Sweden and Reykjavik in Iceland are all examples of communities that have achieved approximately complete energy self-sufficiency combining solar, wind, hydro, geothermal and biomass resources (EEE, 2008; EuropeanCommision, 2014; ForumForTheFuture, 2011). However, although the use of renewable energy sources (RES) is increasing, it is mainly the result of isolated activities and less from fully organized movements, while total energy independence without the support of a centralized electrical grid is yet to be achieved.

This paper reports the results of the project Green ENERGY for Islands (GENERGIS): a renewables-based scenario for electricity autonomy of an island in the Mediterranean, Skyros. GENERGIS was a project supported by the European Commission, which (1) addressed the energy independence of remote areas (islands), including energy storage systems, without which complete independence is not feasible, (2) involved the people of the community in the decision-making process, (3) included detailed technical calculations through simulations, as well as economic and environmental analyses, and (4) resulted in the proposal of concrete energy plans for achieving 100% sustainable living. Additionally, a guide on sustainable development based on social, environmental and economic data was created.

The proposed stand-alone hybrid power plant for the sustainable energy autonomy of Skyros aims to fully satisfy the electricity energy demand of Skyros with 100 % use of renewable resources. Hybrid power systems obtain integrated output from multiple energy sources to achieve synergistic efficiencies and to overcome economic, technological and environmental concerns of individual technologies (Floudas et al., 2012). Such systems can offer stable and secure operation, while they can also establish a more competitive environment for RES (Bhandari et al., 2014; Mezzai et al., 2014; Peterseim et al., 2014) by taking advantage of the benefits of individual technologies and allowing their complementary coupling (Bernardos et al., 2013). Hybrid systems can also play a very important role in remote locations, because they can provide cost savings when compared with single RES power generation (Bajpai and Dash, 2012; Bhandari et al., 2014; Bianchi et al., 2014; Nixon et al., 2012). To develop a stand-alone RES plant, while at the same time minimizing the probability of operational failures, the system must be optimized [e.g., (Mohammad Rozali et al., 2014; Rezvani et al., 2015; Xydis, 2013)]. In this work, the proposed renewable hybrid power plant is tested under extreme conditions of energy demand and climatic conditions. To achieve reliable and robust operation, the power plant is substantially oversized, combines renewable

technologies with complementary character and includes storage facilities. In contrast to other studies related to off-grid hybridization systems (Bernardos et al., 2013; Chowdhury et al., 2015), a fossil-fuel system operating with diesel is only considered for emergency purposes and not actually used as a supporting and stabilizing mechanism of the plant. In addition, for the first time a relatively large remote region with a population of approximately 3,000 people is considered in such a study.

The case study of Skyros

Skyros belongs to the prefecture of Evvoia and the region of Central Greece. The island is situated in the most southern part of the northern Sporades in the Aegean Sea and it is the biggest island (208,594 km²) in the Sporades group (DAFNE, 2010).

According to the census of 2011, Skyros has 2,994 permanent residents (increased from 2,711 in 2001) (Hellenic Statistical Authority -ELSTAT, 2009) with 1,638 men and 1,356 women (ELSTAT, 2014). It is a small-sized island based on its population (> 1,000 and < 10,000 inhabitants) (DAFNE, 2009), characterized by a relatively low population density (< 20 inhabitants/km²). Skyros is largely populated by young people with approximately half of its permanent population being younger than 39 years old (ELSTAT, 2014).

Table 1

The island has 19 settlements, four of which are on the small islets on its surroundings (Hellenic Statistical Authority -ELSTAT, 2012) (Table 1). Most of the permanent inhabitants of Skyros (55.3 %) reside in Chora, a.k.a. Skyros (in the northeastern part of the island), while the rest reside in other smaller settlements.

The climate of Skyros is Mediterranean, with cool summers and mild winters (Hellenic National Meteorological Service - HNMS, 2015). The mean annual temperature on the island is 17 °C with the absolute maximum temperature at 42.6 °C and the absolute minimum temperature at -3.6 °C. The presence of clouds is frequent, while rainfall is sparse throughout the year.

Geomorphologically, Skyros (Map 1) consists of two distinct regions with strong geological contrasts: the northwestern part characterized by smooth terrain and plains (covered by a dense pine forest) and the southeastern part dominated by fallow and

rocky mountains (with tallest the mountain of Korchilas at 792 m) (Municipality of Skyros, 2013).

Map 1

Skyros has a variety of natural areas of special ecological importance placed under national and international protection. Areas that belong to the Network NATURA 2000, sites of exceptional natural beauty (study of the National Technical University of Athens on behalf of the Ministry for the Environment, Physical Planning and Public Works), wildlife shelters and other environmentally important areas (Municipality of Skyros, 2013; Portolou, 2015) are depicted in the deliverables of the project GENERGIS. (Petrakopoulou, 2015).

Map 2

The island presents low seasonal variation in tourism. This implies a limited and controlled increase in energy demand only during the summer months, especially in comparison to other islands of concentrated touristic development. According to data provided by the Hellenic Statistical Authority for 2009, Skyros receives annually approximately 7,000 tourists that are associated with 25,000 overnights on the islands (Panagiotopoulou and Betaplan AEM, 2009)(Hellenic Statistical Authority -ELSTAT, 2014).

The islanders on Skyros are engaged in agriculture, animal husbandry (it is famous for its small horses), fishing, small industry and resin collection. The island produces honey, fruit and husbandry products (e.g., different types of cheese). The island is also famous for its marble, the art of furniture making and pottery.

Based on the registry of businesses on Skyros, last updated in 2005 (geodata.gov.gr, 2010), 23.0 % of the 343 registered businesses on Skyros deal with retail, followed by

food and beverage services (19.5 %), accommodation services (13.1 %) and specialized construction activities (8.8 %). Most of the activities associated with the primary sector take place in the valleys Trachy, Kallikri and around the area of Magazia. Lastly, most of the activities of the secondary and tertiary sectors are found in the Chora of the island.

Methodology

The hybrid power plant presented in this paper is evaluated using an exergetic analysis. Exergy is separated into physical, kinetic, potential and chemical parts. The physical exergy of a material stream is determined by its pressure and temperature, while its chemical exergy is determined by its chemical composition. The kinetic and potential exergy are equal to the kinetic and potential energy.

The exergy of solar power received by the sun (exergy of the fuel of the solar field or photovoltaic, PV, array) in the case of the solar-based plants is calculated using the following equation (Petela, 2003):

$$\dot{E}_{sun} = \dot{Q} \cdot \Psi_s$$

where, \dot{Q} is the solar irradiation available from the sun (global horizontal irradiation, *GHI*, in the case of the PV plants) and Ψ_s is the ratio between exergy and energy calculated as:

$$\Psi_s = \left[1 - \frac{4}{3} \left(\frac{T_a}{T_s} \right) + \frac{1}{3} \left(\frac{T_a}{T_s} \right)^4 \right]$$

where, T_a is the ambient temperature and T_s is the apparent black body temperature of the sun (5,600 K).

The input exergy of wind, that is also the exergy of fuel of the wind turbines, is the kinetic power of the wind calculated as:

$$\dot{E}_{wind} = \frac{1}{2} \cdot m \cdot v^2 = \frac{1}{2} \cdot \rho \cdot A \cdot v^3$$

where, m is the mass flow rate of the air going through the wind turbine's swept area, ρ is the density of the air (1.23 kg/m³), A is the total swept of the wind turbines and v is the wind speed.

An exergetic analysis is the first step in evaluating an energy conversion system, identifying the source and cause of incurred thermodynamic inefficiencies.(Bejan et al., 1995) With exergy-based analyses, information about improvements of an energy conversion system is revealed, which is particularly useful for minimizing inefficiencies at the design and planning stages of the evaluation of new energy conversion systems.

To realize an exergetic analysis, the system boundary of the analyzed plant must first be defined. Each component k within the thermodynamic system is characterized by its exergy of the fuel and its exergy of the product ($\dot{E}_{F,k}$ and $\dot{E}_{P,k}$). The fuel of a component is the expense in exergetic resources for the generation of the desired output, while the product is the exergy of the desired output resulting from the operation of the component. The exergy of the fuel and product are defined based on the operation and purpose of each component within an analyzed system.(Lazzaretto and Tsatsaronis, 2006; Tsatsaronis and Cziesla, 2004) The exergetic efficiency, ε_k , of a component that demonstrates its thermodynamic performance is the ratio of the exergy of the product to the exergy of its fuel. The difference between the exergy of the fuel and product at the component-level represents the exergy destruction within a component ($\dot{E}_{D,k} = \dot{E}_{F,k} - \dot{E}_{P,k}$), while at the system-level it represents the sum of exergy destruction and exergy loss of the overall system ($\dot{E}_{D,tot} + \dot{E}_{L,tot} = \dot{E}_{F,tot} - \dot{E}_{P,tot}$).

Simulation of the hybrid power plant

The plant proposed is a hybrid of a PV system and wind turbines, supported by electricity storage and a hydrogen-generation facility (Figure 1). The power plant is simulated using the commercial software EpsilonProfessional and it is further evaluated thermodynamically with an exergetic analysis.

Figure 1

The peak energy and total annual demand of the simulated plant are determined from the hourly demand time series of the island, as projected to the last year of the economic life of the power plant. The plant is assumed to start operation in 2020 and to have an economic life of 25 years. The 2012 hourly time series of electricity demand on Skyros was extrapolated to 2045 with an annual energy increase of 1.4 % (DEDDIE - Island Management Division, 2013). The existing diesel generator on the island is expected to be used as a back-up technology initially to ensure no power outages in the case of unpredicted events. This has a twofold purpose: to provide flexibility to the personnel operating the new plants to familiarize themselves with the function and requirements of the new technologies and to replace the diesel generator in a more gradual manner.

Figure 2

The input data of the simulation of the power plant can be seen in Figure 2. The solar data have been derived from Ref. (MACC-RAD service, 2012), while the wind speed time series (third panel of Figure 2) was generated using the mean wind speed of the years 2010-2014. The wind speed data (Hellenic National Meteorological Service, 2014) was extrapolated from the height of the meteorological station (4 m) to the height of the hub of the considered wind turbines (84 m) using the logarithmic profile of wind shear (Kishore and et al., 2010):

$$\frac{V}{V_{ref}} = \left(\frac{z - z_0}{z_{ref} - z_0} \right)^{0.14}$$

where, V is the velocity of the wind to be calculated at the height z , V_{ref} is the known velocity at the height z_{ref} , z is the height above ground level for velocity V (84 m), z_{ref} is the reference height (4 m) and z_0 is the roughness length in the current wind direction (0.03 m for “open agricultural area without fences and hedgerows and very scattered buildings. Only softly rounded hills”).

When the solar irradiation is adequate, the required electricity is generated using the PV array, while any existing surplus is sent to the electricity storage. At night or during cloudy days the energy demand is covered by the wind turbines. Any energy surplus from the turbines is also stored in the electric battery, if necessary. When the solar irradiation and wind speed levels are not sufficient to cover the energy demand, the electric battery is used to ensure continuous operation and eliminate power shortages. Any energy surplus remaining after covering the energy demand and charging the battery is led to the electrolyzer of the plant to generate H_2 .

The sizes of the PV system, wind turbines and electric storage options are optimized for maximizing power coverage. The PV array is designed with a maximum power output of 10.5 MW. The panels used in the simulation are monocrystalline silicon panels based on the model EP156M/60-250W of the company Eoply New Energy Technology Co., Ltd. Each panel includes 60 cells, has a peak efficiency of 15.3 % and generates 153.0 W/m² under standard test conditions (SolarDesignTool, 2015). The power generation of the PV array is estimated using the following equation:

where, $A_{PV,k}$ is the area of each panel (summing up to 68,628 m²), GHI is the global horizontal irradiation, k is the number of PV panels, η_{PV} the efficiency of the panels and PR the performance ratio of the array (76 % assuming losses of 24 %).

The PV plant is composed of the PV modules (PV generator), an inverter for converting the direct current of the PV output into alternating current, mounting and racking components, a combiner box and other electrical components (wires, conductors, data monitoring system, etc.).

The simulation of the wind turbines assumes wind turbines of the type Vestas V112-3.3 MW™ IEC IB (Vestas, 2015). Each wind turbine has rated power output of 3.3. MW, a hub height of 84 meters, a rotor diameter of 112 m with swept area 9,852 m² and cut-in and cut-out speeds of 3 and 25 m/s. The components constituting the wind plant are: turbines (generators, nacelles, blades), turbine foundations (towers), power transformers (at each turbine and a substation), cables for carrying power and electronic signal, a substation and switching equipment for interconnection into a high-voltage grid and other electrical equipment.

It is found that three wind turbines can ensure self-reliant operation of the hybrid power plant. The turbines are placed upwind in one row with a 4D distance between them ((2 x 4D) + D = 1,008 m), 1D empty space in their front and 1D in their rear sides. The area needed for the three wind turbines is 0.23 km².

To further ensure continuous and reliable performance of the power plant during energy peaks and challenging weather conditions (long cloudy periods in the winter season and low wind speeds) its operation is supported by an electricity storage system. The incorporated storage system consists of NaS batteries with a storage potential of 140 MWh (10 2-MW units with discharge time of 7 hours). With volume energy densities of sodium-sulfur batteries between 200-300 kWh/m³ the proposed hybrid

plant requires 793-1,190 m³ of sodium-sulfur batteries to cover the required needs of the simulated plant.

The electrolyzer of the plant, an intermediate-temperature solid-oxide electrolysis cell (Petrakopoulou et al., 2015), uses electricity to convert any electricity surplus into hydrogen through water electrolysis. The electrolysis cells work at thermoneutral voltage, at a temperature of 700 °C with a steam conversion rate in the cathode chamber of 61 % and a molar ratio between the anode and cathode of 1:1. Under these operational conditions, the overall energy efficiency of the electrolyzer, defined as the ratio between the lower heating value of the generated hydrogen and the stack power needed to perform this task, is 97.2 %. The generated hydrogen is finally compressed to 150 bar and stored (Kroposki, 2009). The purpose is to use any energy residual to generate a secondary product that can be sold for use in other chemical processes (e.g., ammonia, methane generation) or for other purposes (e.g., future filling stations of H₂-driven vehicles). In this way, we can achieve an additional financial benefit for the power plant operation.

Evaluation of the power plant

The hybrid power plant is examined with an exergetic analysis at the component level while operating at full load. The system boundaries of the analysis include the complete hybrid plant, while the calculation of the physical exergy is based on ambient temperature and pressure of 20 °C and 1.013 bar.

It should be noted that, most of the time, the plant is required to operate at partial load, due to design restrictions related to energy demand and weather variation. These variations cause significant fluctuations to the efficiency of the plant. To include these operational fluctuations in the overall evaluation of the plant, a mean annual efficiency is calculated for the plant based on the generated time series of energy input and output over one year. The annual efficiency of the hybrid plant combines the net mean contributions of each renewable technology.

Figure 3

Figure 3 shows the performance of the hybrid power plant. As seen in the second panel of the figure the PV power output is high during the summer months and relatively low during the winter period because of relatively lower levels of irradiation. The wind turbines supplement the energy deficits during the winter and high demand periods in the summer season by operating with relatively high capacities (third panel).

The battery is charged by surpluses of both the PV array and the wind plant and, as can be seen in the fourth panel of Figure 3, it is kept fully charged throughout the year with the exception of periods with high energy peaks. Most of the PV surplus is generated in late spring/early summer when the solar irradiation is relatively high but the energy demand is relatively low. The battery is used in July and August to supplement the increased energy demand of the high-season period and in December to make up for the solar deficit related to the relatively low irradiation.

The average capacity factors of the PV and wind plants are found to be 16.1 and 15.7 %, respectively. It is found that 41 % of the annual energy demand is satisfied through the operation of the PV system and 59 % through the operation of the wind plant. The overall annual surplus of the plant sent to the electrolyzer of the plant is 6,721 MWh. The capacity of the incorporated electrolyzer unit is set to 8.3 MW, i.e., the maximum power surplus of the plant. The annual hydrogen generation in the electrolyzer is found to be 253 tonnes.

The exergy of the fuel of the PV system is the exergy received from the sun, \dot{E}_{sun} , calculated using the GHI. The exergy of the product of the PV array is the power output calculated based on its performance factor, overall efficiency and area. The PV operates with the same maximum efficiency of 12.5 % both at full and partial load because both its exergy of fuel and product depend on the solar irradiation (GHI) and their variation follows a linear relationship.

The exergetic efficiency of the 3.3 MW wind turbines at full load operation is 31.6 %. The maximum possible efficiency that each wind turbine can reach is 45.7 % with a wind speed of 8.3 m/s. When considering the mean annual conditions, the wind turbines operate with an efficiency of 20.1 %.

The exergetic analysis of the electrolyzer unit at full load is shown in Table 2. Under maximum surplus conditions (8.3 MW), the process generates 0.085 kg/s H₂ with an exergy output of 5.5 MW.

Table 2

As seen in Table 2 **Error! Reference source not found.**, the exergetic efficiency of the electrolyzer unit is found to be 66.8 %. The electrolyzer itself is responsible for approximately 17 % of the overall exergy destruction of the unit, while the highest contribution to the irreversibilities of the plant (45 %) are found for the EH3 used to

evaporate the incoming water before it is sent to the electrolysis process. The total exergy destruction of the intercooled compression unit (Compressors 2-6 and Coolers 1-3) results in a 28 % contribution to the total exergy destruction of the plant.

The mean annual power residual used in the electrolyzer is calculated to be approximately 765 kW. At this power input, the electrolyzer generates 0.008 kg/s H₂ with exergy output of approximately 0.5 MW.

Table 3

Accounting for the mean annual exergy values shown in Table 3, the overall annual mean efficiency of the hybrid plant (PV – wind – H₂ plant with storage) is calculated as:

$$\varepsilon_{mean,hybrid} = \frac{\dot{E}_{P,hybrid}}{\dot{E}_{F,hybrid}} = \frac{\dot{E}_{P,PV,mean} + \dot{E}_{P,wind,mean} + \dot{E}_{P,electrolyzer,mean}}{\dot{E}_{F,sun,mean} + \dot{E}_{F,wind,mean}}$$

with $\dot{E}_{F,sun,mean}$ the mean annual solar exergy received from the sun calculated with the mean value of GHI, $\dot{E}_{F,wind,mean}$ the mean exergy of the fuel of the wind, $\dot{E}_{P,electrolyzer,mean}$ the mean annual exergy of the product of the electrolyzer (exergy of generated hydrogen), $\dot{E}_{P,PV,mean}$ the net mean annual exergy of the product of the PV plant and $\dot{E}_{P,wind,mean}$ the net mean exergy of the product of the wind turbines.

Based on the above calculations, the mean annual exergetic efficiency of the PV-wind plant with electricity storage and hydrogen generation is found to be 17.9 %.

Within the framework of the project GENERGIS two alternatives for the 100 % renewable energy autonomy of the island of Skyros were examined. The first option included a concentrating solar power plant with thermal storage and wind turbines coupled with electricity storage, while the second choice included photovoltaic panels, wind turbines and a pumped-storage hydropower plant coupled with an electrolyzer. The power plants were evaluated based on their exergetic performance and the

associated economic expenditures. When comparing the plant presented here with the two alternatives, it is seen that this plant achieves the second best exergetic efficiency and land requirement. Nevertheless, the economic analysis reveals this plant as the best choice due to its lower fixed capital investment that results in the lowest cost of electricity.

Discussion and conclusions

The existing relatively large number of studies of hybrid systems shows their essential role in the scientific community. However, only limited work on hybrid systems specifically designed for off-grid applications exists, and so far, studies are based on simple structures and assumptions (Floudas et al., 2012). There is thus the need for a thorough, consistent comparison of the coupling of several renewable technologies to reveal possible and promising alternatives. This lack of an extended and robust evaluation constitutes the motivation and underlines the originality of the present paper.

This paper presented the dynamic simulation and thermodynamic evaluation of a hybrid power plant for the 100 % renewable electricity autonomy of an island in Greece. The results of the research can be used as an example to academic and private bodies, as well as policy makers. The hybrid plant combined a photovoltaic park with wind turbines and electricity storage facilities. The plant was also coupled with an intermediate-temperature electrolyzer for hydrogen generation, operating with the generated electricity residual.

To include operational fluctuations in the overall evaluation of the plant, a mean annual plant efficiency was calculated based on the generated time series of energy input and output over one year. The annual efficiency of the plant (i.e., the net mean contribution from each primary renewable energy technology) was found to be 17.9 %. 41 % of the annual energy demand of the island of 21,628 MWh by 2045 is satisfied through the operation of the PV system and 59 % through the operation of the wind plant. The overall annual surplus of the plant sent to the electrolyzer unit was 6,721 MWh and the annual hydrogen generation was at 253 tonnes.

Overall it was seen that the hybridization of wind with solar provided a robust solution for the 100 % renewable electricity coverage of isolated regions. The two technologies

complement each other and offer the possibility for more stable and more predictable performance. This study shows that hybrid plants can overcome existing obstacles of renewable energy technologies especially in regions where current energy facilities are relatively expensive and environmentally harmful.

Comparing the plant presented here with two alternatives for the 100 % renewable energy autonomy of the island of Skyros (Petrakopoulou, 2015), it is seen that this plant achieves the second best exergetic efficiency and land requirement. Lastly, the efficiency of the plant presented here is relatively low when compared to other hybrid alternatives that include fossil fuels. However, the associated reduction in greenhouse gas emissions and zero cost of input energy fuel make its realization attractive for future sustainable energy endeavors.

Lastly, it should be mentioned that in order for renewable hybrid power plants to achieve stand-alone operation, their capacity must be sufficiently oversized and they must include large storage facilities. This means that such power plant structures will be associated with significantly higher investment costs than conventional plants. The cost of the storage facilities, specifically, is a very significant portion of the overall costs of the plant and it depends on the technology used, the size of the unit and the number of replacements of the unit within the lifetime of the project. Economic estimates of the power plant presented here show that approximately 20 % of the investment cost of the plant must be allocated for the battery storage facility alone (see (Petrakopoulou, 2015)). However, because the power plant is based on renewable resources, it eliminates the cost of fuel and ensures environmental sustainability in the long term.

Acknowledgments

The authors would like to acknowledge the Marie Curie Actions PEOPLE-2012-IEF-GENERGIS-332028 and COFUND CONEX funded by FP7.

References

- Bajpai, P., Dash, V., 2012. Hybrid renewable energy systems for power generation in stand-alone applications: A review. *Renew. Sustain. Energy Rev.* 16, 2926–2939.
- Bejan, A., Tsatsaronis, G., Moran, M., 1995. *Thermal Design and Optimization*. Wiley-Interscience.
- Bernardos, E., López, I., Rodríguez, J., Abánades, A., 2013. Assessing the potential of hybrid fossil–solar thermal plants for energy policy making: Brayton cycles. *Energy Policy* 62, 99–106.
- Bhandari, B., Lee, K.-T., Lee, C.S., Song, C.-K., Maskey, R.K., Ahn, S.-H., 2014. A novel off-grid hybrid power system comprised of solar photovoltaic, wind, and hydro energy sources. *Appl. Energy* 133, 236–242.
- Bianchi, M., Branchini, L., Ferrari, C., Melino, F., 2014. Optimal sizing of grid-independent hybrid photovoltaic–battery power systems for household sector. *Appl. Energy* 1–12.
- Chowdhury, S.A., Aziz, S., Groh, S., Kirchhoff, H., Leal Filho, W., 2015. Off-grid rural area electrification through solar-diesel hybrid minigrids in Bangladesh: resource-efficient design principles in practice. *J. Clean. Prod.* 95, 194–202.
- DAFNE, 2009. Strategic study on energy savings, the promotion of renewable energy sources and the reduction of emissions in the Aegean islands (available in Greek) [WWW Document]. URL [http://www.aegean-energy.gr/gr/pdf/Strategic Energy Planning.pdf](http://www.aegean-energy.gr/gr/pdf/Strategic_Energy_Planning.pdf) (accessed 4.9.15).
- DAFNE, 2010. Sustainable Energy Action Plan for the Municipality of Skyros under the “Covenant of Mayors.” (available in Greek).
- DEDDIE - Island Management Division, 2013. Personal Communication.
- EEE, 2008. www.eee-info.net [WWW Document]. Güssing Best Pract. Renew. Energy Initial Situat. “Model Güssing” - Decentralized local energy Prod. by using local available Renew. Resour. URL www.eee-info.net.
- ELSTAT, 2014. Interactive Map - Population and residential census 2011: Data of Permanent Population [WWW Document]. URL <http://www.statistics.gr/portal/page/portal/ESYE/PAGE-interactive-census-map> (accessed 3.13.15).
- EuropeanCommision, 2014. Renewable Energy for Europe [WWW Document]. 100% Renew. Energy Communities. URL http://ec.europa.eu/energy/idae_site/deploy/tablas/100_re_communities_title.html (accessed 8.7.12).
- Floudas, C. a., Elia, J. a., Baliban, R.C., 2012. Hybrid and single feedstock energy processes for liquid transportation fuels: A critical review. *Comput. Chem. Eng.* 41, 24–51.

- ForumForTheFuture, 2011. Discover Community Energy [WWW Document]. URL <http://www.forumforthefuture.org/sites/default/files/images/Overview of Germany tour download.pdf>
- geodata.gov.gr, 2010. Μητρώο Επιχειρήσεων [WWW Document]. URL http://geodata.gov.gr/geodata/index.php?option=com_sobi2&sobi2Task=sobi2Details&catid=21&sobi2Id=48&Itemid=
- Hellenic National Meteorological Service, 2014. Personal communication [WWW Document]. URL http://www.hnms.gr/hnms/greek/index_html (accessed 4.11.15).
- Hellenic National Meteorological Service - HNMS, 2015. Climatology - Skyros [WWW Document]. URL http://www.hnms.gr/hnms/english/climatology/climatology_region_diagrams_html?dr_city=Skyros (accessed 4.8.15).
- Hellenic Statistical Authority -ELSTAT, 2009. Digital library (ELSTAT) [WWW Document]. URL http://dlib.statistics.gr/portal/page/portal/ESYE/showdetails?p_id=13321502&p_derive=book&p_topic=10007862 (accessed 3.18.15).
- Hellenic Statistical Authority -ELSTAT, 2012. Permanent population of the country [WWW Document]. URL http://www.statistics.gr/portal/page/portal/ESYE/BUCKET/General/A1602_SAM01_DT_DC_00_2011_02_F_GR.pdf (accessed 3.18.15).
- Hellenic Statistical Authority -ELSTAT, 2014. Personal communication - ELSTAT.
- IPCC, 2005. IPCC Special Report - Carbon Dioxide Capture and Storage — Working Group III. Cambridge University Press, Cambridge, United Kingdom and New York, NY, USA.
- IPCC, 2007. Climate Change 2007: Mitigation. Contribution of Working Group III to the Fourth Assessment Report of the Intergovernmental Panel on Climate Change. United Kingdom and New York.
- Kishore, V.V.N., et al., 2010. Renewable Energy Engineering and Technology: principles and practice, Revised International Edition. The Energy and Resources Institute (TERI).
- Kroposki, B., 2009. Distributed Energy Systems Integration Group - NREL [WWW Document]. URL <http://www.nrel.gov/docs/fy10osti/46439.pdf> (accessed 6.7.15).
- Lazzaretto, A., Tsatsaronis, G., 2006. SPECO: A systematic and general methodology for calculating efficiencies and costs in thermal systems. *Energy* 31, 1257–1289.
- MACC-RAD service, 2012. Time series of solar radiation data [WWW Document]. URL <http://www.soda-pro.com/about-us> (accessed 6.12.15).
- Mezzai, N., Rekioua, D., Rekioua, T., Mohammedi, a., Idjarane, K., Bacha, S., 2014. Modeling of hybrid photovoltaic/wind/fuel cells power system. *Int. J. Hydrogen Energy*.

- Mohammad Rozali, N.E., Wan Alwi, S.R., Abdul Manan, Z., Klemeš, J.J., Hassan, M.Y., 2014. Optimal sizing of hybrid power systems using power pinch analysis. *J. Clean. Prod.* 71, 158–167.
- Municipality of Skyros, 2013. Demonstration of the Biodiversity Action Planning approach, to benefit local biodiversity on an Aegean island, Skyros - LIFE09NAT/GR/000323.
- Nixon, J.D., Dey, P.K., Davies, P.A., 2012. The feasibility of hybrid solar-biomass power plants in India. *Energy* 46, 541–554.
- Panagiotopoulou, I.M., Betaplan AEM, 2009. Spatial Plan and Urban Organization of Open City of the Municipality of Skyros.
- Petela, R., 2003. Exergy of undiluted thermal radiation. *Sol. Energy* 74, 469–488.
- Peterseim, J.H., White, S., Tadros, A., Hellwig, U., 2014. Concentrating solar power hybrid plants – Enabling cost effective synergies. *Renew. Energy* 67, 178–185.
- Petrakopoulou, F., 2015. GENERGIS (Green Energy for Islands) 2012-IEF-332028, IEF Project supported by FP7 [WWW Document]. URL http://www.genergis.eu/home_en (accessed 7.24.15).
- Petrakopoulou, F., Sanz-Bermejo, J., Dufour, J., Romero, M., 2015. Exergetic Analysis of Hybrid Power Plants with Biomass and Photovoltaics Coupled with a Solid-Oxide Electrolysis System. *Energy*.
- Portolou, D., 2015. Personal Communication - Hellenic Ornithological Society [WWW Document]. URL <http://www.ornithologi.gr/> (accessed 4.6.15).
- Rezvani, A., Gandomkar, M., Izadbakhsh, M., Ahmadi, A., 2015. Environmental/economic scheduling of a micro-grid with renewable energy resources. *J. Clean. Prod.* 87, 216–226.
- SolarDesignTool, 2015. Eoply New Energy EP156M/60-250W (250W) Solar Panel [WWW Document]. URL <http://www.solardesigntool.com/components/module-panel-solar/Eoply-New-Energy/2214/EP156M-60-250W/specification-data-sheet.html> (accessed 6.12.15).
- The republic of Lithuania, 2012. Energy Independence - Common Goal of the Baltics [WWW Document]. URL <http://eurodialogue.org/energy-security/Energy-Independence-Common-Goal-Of-The-Baltics>
- Tsatsaronis, G., Czielsa, F., 2004. Energetic and exergetic analysis of complex systems. *Encycl. Life Support Syst.*
- UNFCCC, 2008. Kyoto Protocol Reference Manual on accounting of emissions and assigned amount.
- Vestas, 2015. Wind Turbine - V112-3.3/3.45 MW™ [WWW Document]. URL http://www.vestas.com/en/products_and_services/turbines/v112-3_3_mw (accessed 6.12.15).

Xydis, G., 2013. On the exergetic capacity factor of a wind – solar power generation system. *J. Clean. Prod.* 47, 437–445.

Captions

Figure 1: Simulation flow diagram of the PV-wind power plant supported by electricity storage and a H₂-generation facility².

Figure 2: Input hourly data used in the dynamic simulation of the hybrid power plant (daily mean shown by thick darker lines).

Figure 3: Performance of the PV-wind power plant with electricity storage (daily mean shown by thick darker lines).

Map 1: Shaded-relief map of Skyros.

Map 2: Map of Skyros (Software QGIS V.2.2.0, modified from Ref. (Municipality of Skyros, 2013)).

Table 1: Permanent inhabitants of Skyros and neighboring islets according to the census of 2011 (Hellenic Statistical Authority -ELSTAT, 2012).

Table 2: Results of the exergetic analysis at the component level of the electrolyzer unit.

Table 3: Calculated exergy values at full-load/maximum and mean annual operation of each RES technology.

Figures

Figure 1

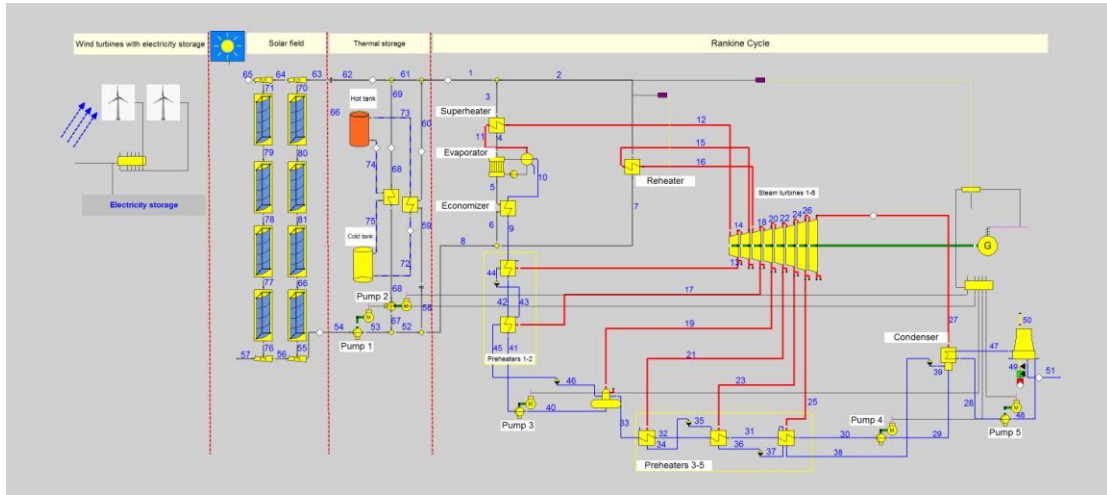

Abbreviations: HX: heat exchanger, EH: Electric heater.

Figure 2

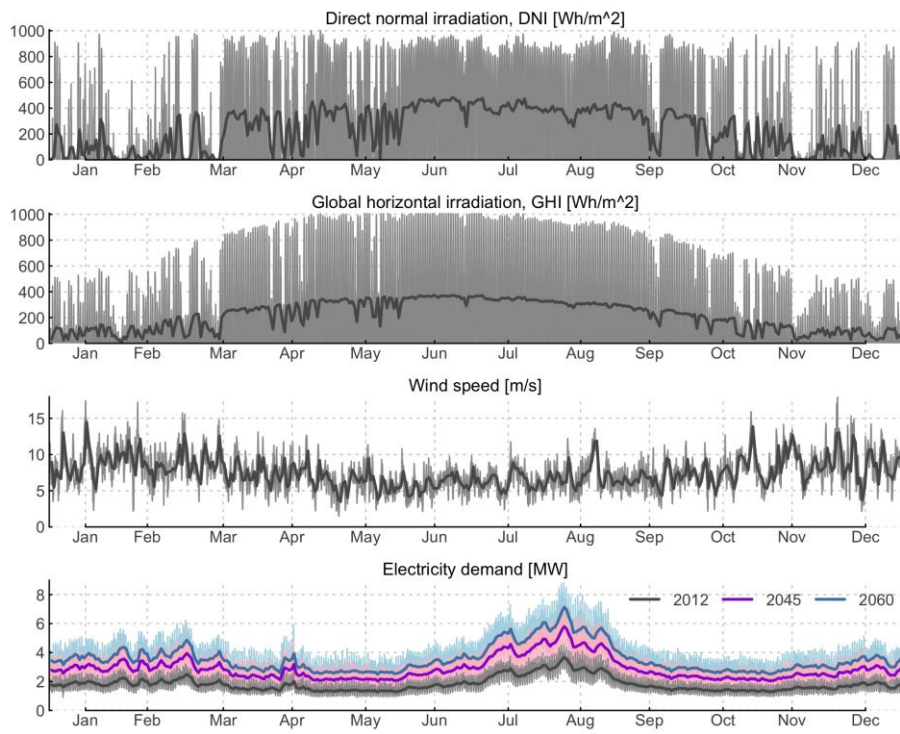
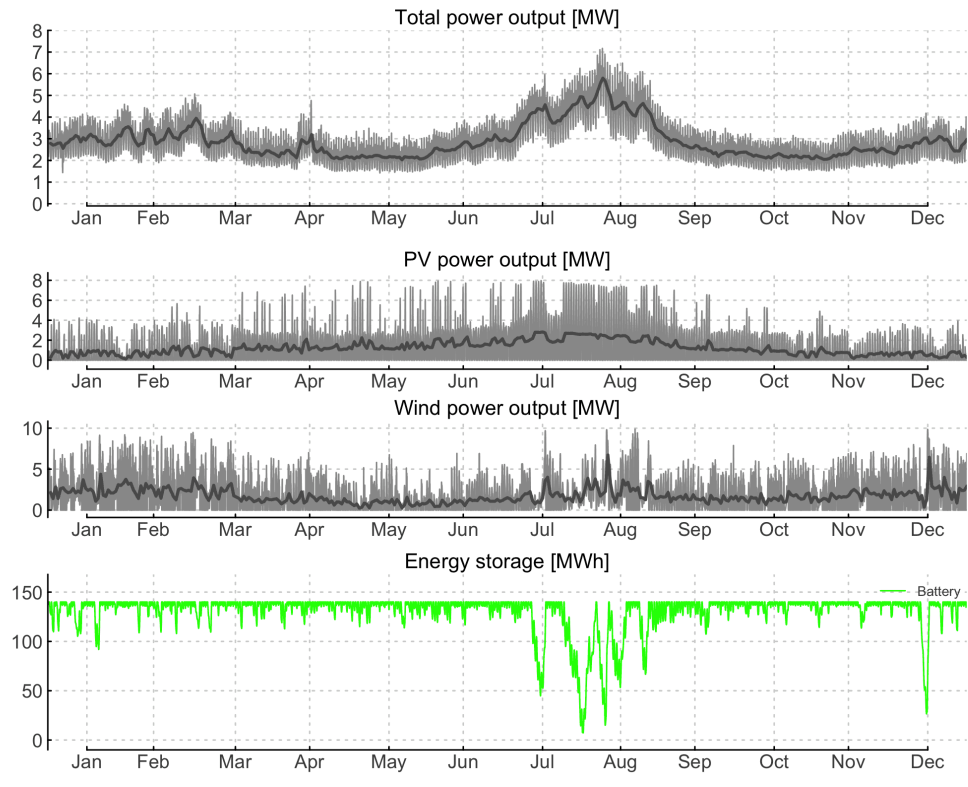
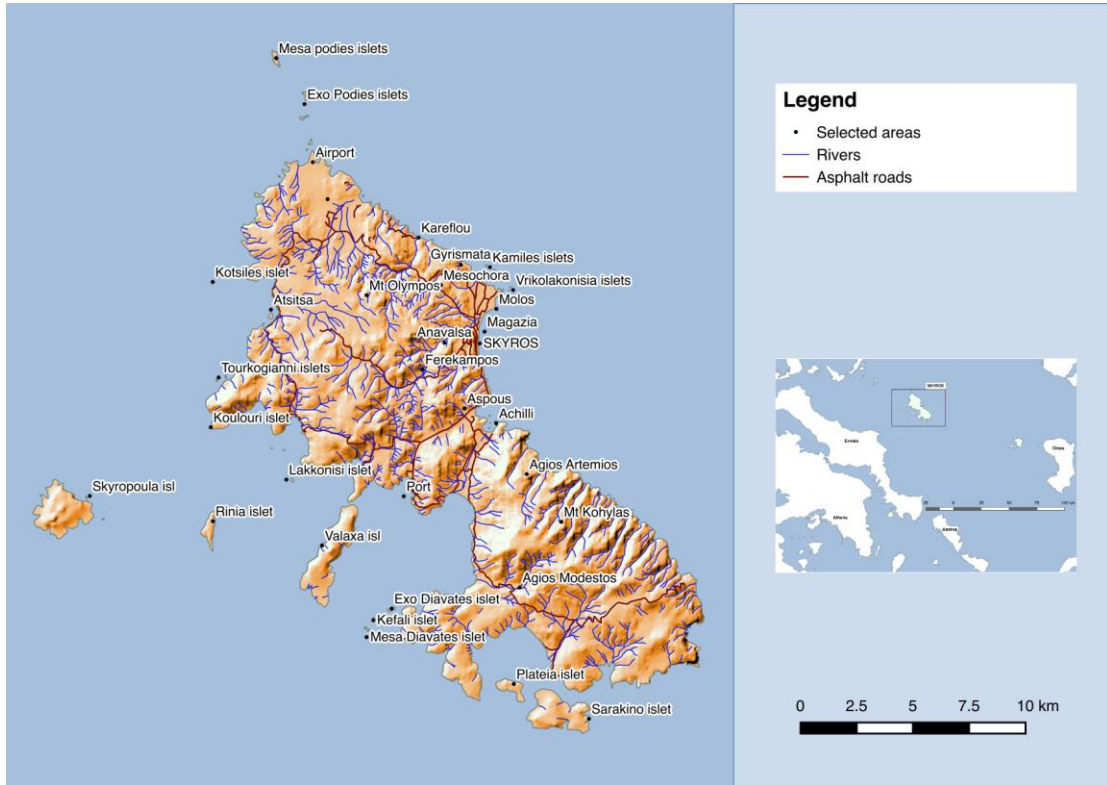

Figure 3



Maps

Map 1



Map 2

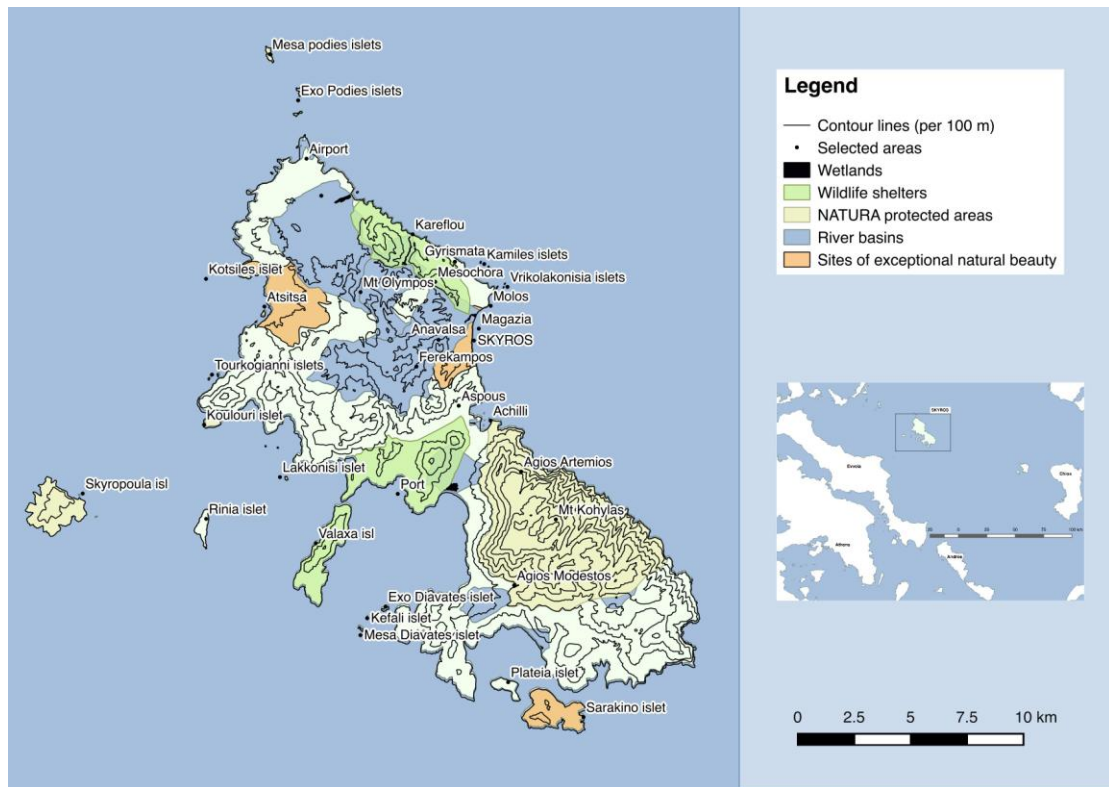

Tables

Table 1

Name of settlement	Permanent residents (2011)
Aspous	107
Atsitsa	13
Acherounes	65
Achilli	53
Ekso Podies (islet)	0
Kalamitsa	43
Kalikri	43
Kira Panagia	0
Linaria	116
Loutro	28
Mela	0
Mesa Podia (islet)	0
Molos	618
Nifi	31
Pefkos	24
Sarakinon (islet)	0
Skyropoula (islet)	0
Skyros (Chora)	1,657
Trachi	196
TOTAL	2,994

Table 2

	\dot{E}_F	\dot{E}_P	\dot{E}_D	ϵ
	[MW]	[MW]	[MW]	[%]
EH1	0.11	0.08	0.04	68.3
EH2	0.03	0.02	0.01	67.8
EH3	1.53	0.35	1.18	22.7
HX1	0.06	0.02	0.04	35.0
HX2	0.47	0.39	0.08	83.5
HX3	0.62	0.35	0.27	56.0
HX4	0.06	0.05	0.01	85.5
Electrolyzer	5.45	5.00	0.45	91.8
Compressor 1	0.02	0.01	0.01	32.5
Compressor 2	0.01	0.00	0.01	31.8
Compressor 3	0.27	0.17	0.10	62.9
Compressor 4	0.31	0.18	0.13	58.0
Compressor 5	0.24	0.13	0.12	52.2
Compressor 6	0.31	0.18	0.13	57.9
Cooler1	0.11	-	0.10	-
Cooler2	0.10	-	0.09	-
Cooler3	0.07	-	0.06	-
Mixer	0.86	0.84	0.02	97.4
Total	8.29	5.53	2.63	66.8
$E_{Ltot}=0.12$				

Table 3

	\dot{E}_F	\dot{E}_P	\dot{E}_D	ϵ
	[MW]	[MW]	[MW]	[%]
PV plant				
<i>Full load</i>	65.7	8.2	57.5	12.5
<i>Mean annual</i>	13.5	1.7	11.8	12.5
Wind farm				
<i>Full load</i>	31.4	9.9	21.5	31.5
<i>Mean annual</i>	10.1	2.0	8.1	20.1
Hydrogen storage				
<i>Full load</i>	8.3	5.5	2.6	66.8
<i>Mean annual</i>	0.8	0.5	0.3	66.8
Electricity storage				
<i>Full load</i>	20.0	19.0	1.0	95.0
<i>Mean annual</i>	1.9	1.8	0.1	95.0

)

Highlights

- Examination of the 100 % renewable electricity autonomy of an island in Greece
- Study of a hybrid solar/wind power plant with storage and hydrogen generation
- The mean annual plant efficiency of the plant is found to be 17.9 %
- The annual hydrogen generation of the plant is 253 tonnes
- The combination of wind and solar provides a robust solution for stand-alone operation

[Click here to download high resolution image](#)

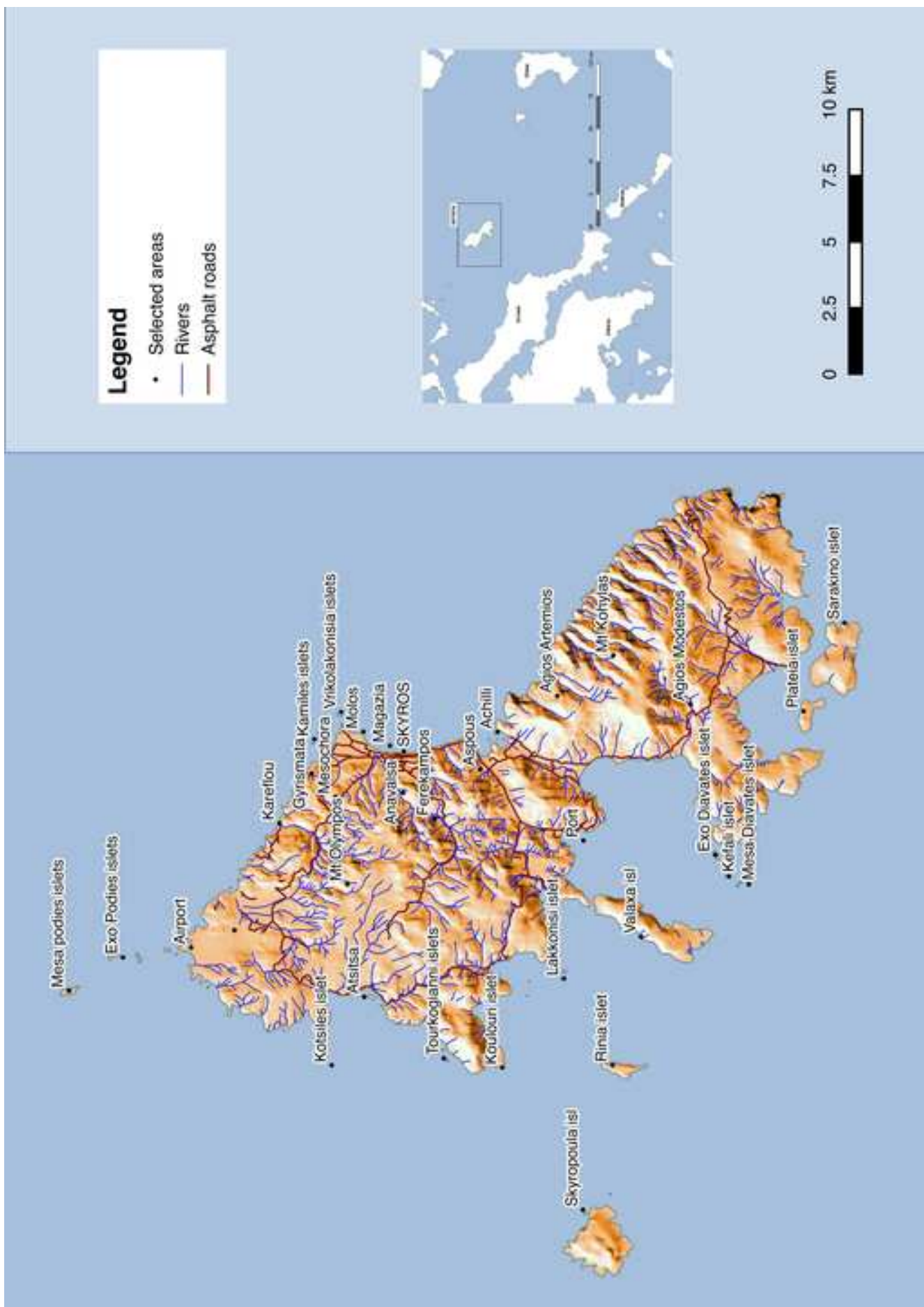

[Click here to download high resolution image](#)

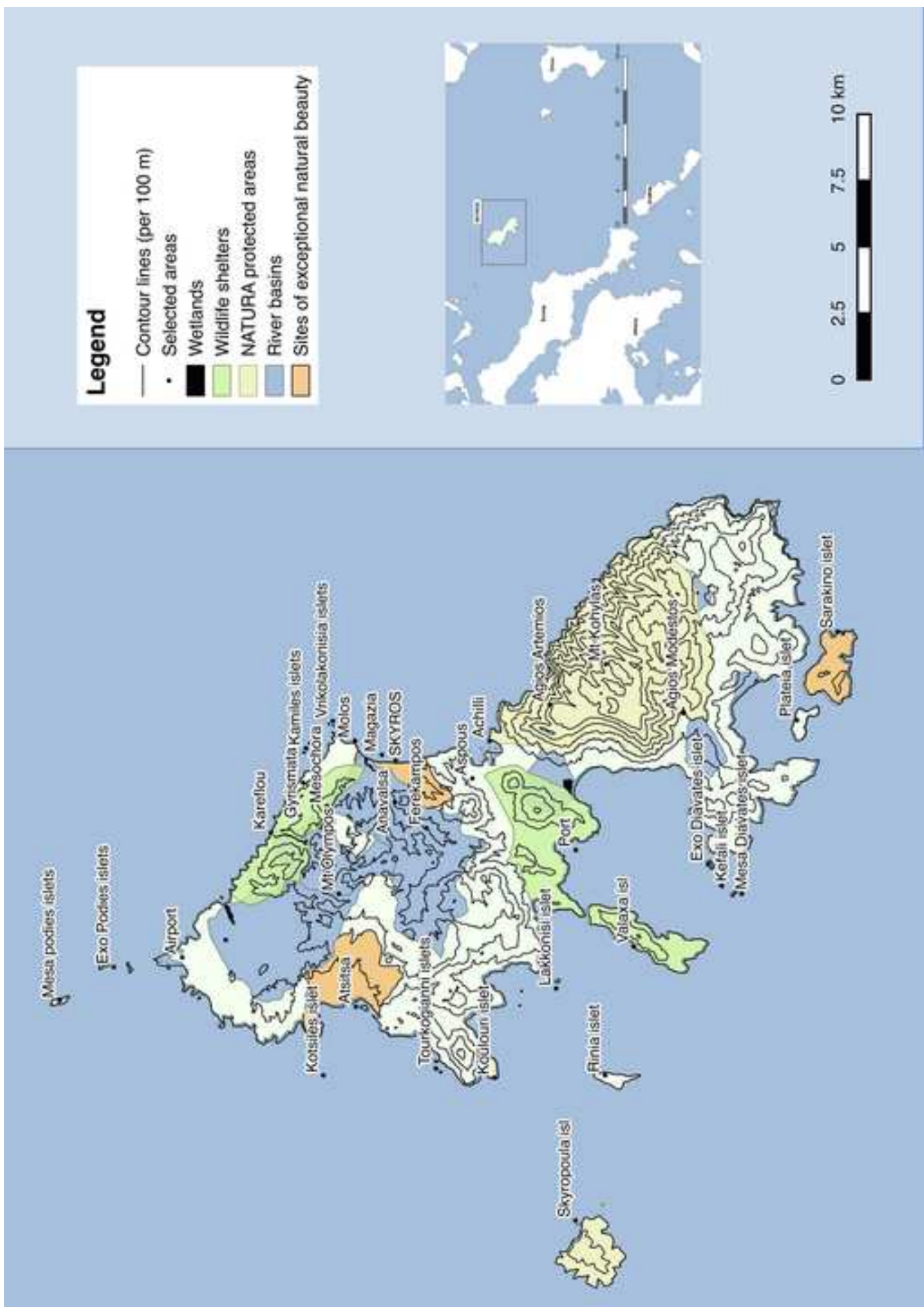

Figure 1
[Click here to download high resolution image](#)

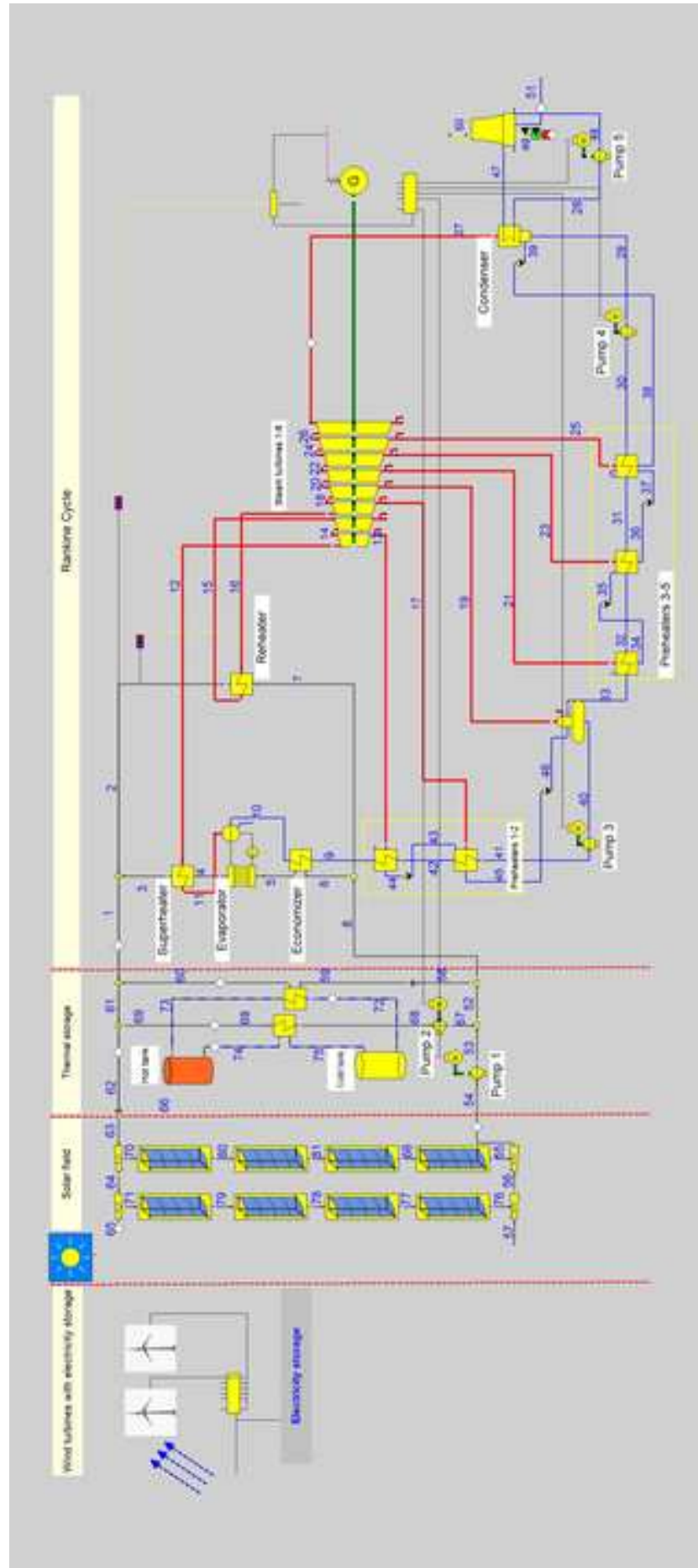

Figure 2
[Click here to download high resolution image](#)

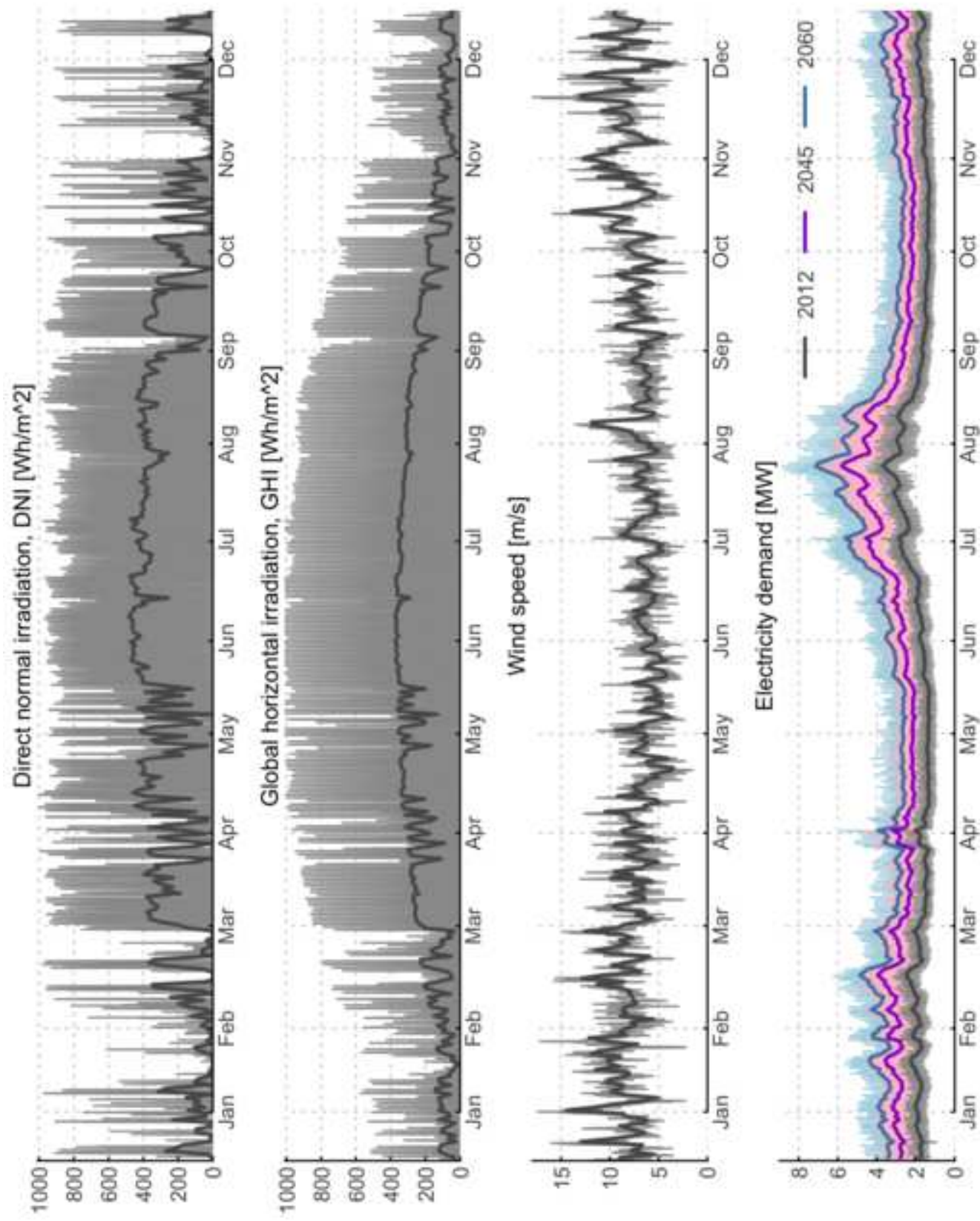

Figure 3
[Click here to download high resolution image](#)

