



UNIVERSITY CARLOS III OF MADRID  
INDUSTRIAL ELECTRONICS AND AUTOMATION ENGINEERING  
BACHELOR THESIS

**Design, construction and programming of a  
low cost, Open Source robot for assistive  
activities**

*Author*  
Alvaro Ferrán Cifuentes

*Supervisor*  
Juan González Vítores

---

## Acknowledgements

First of all, I would like to thank my parents for their unwavering support.

I want to acknowledge Irene, for her support, interest and help throughout the project.

I would like to acknowledge as well my tutor, Juan González Vítores, for the time and help put into this project, and for enabling me to carry it out.

I want to thank as well both Alberto Valero and Juan González Gómez for their enthusiastic approach to teaching and for the “Mars Challenge” project, through which they initiated me into the world of robotics and 3D printing.

Finally, I would like to thank my family and friends for always being there when needed.

## Agradecimientos

Antes de nada quiero agradecer a mis padres el apoyo que me dan siempre.

En primer lugar, un reconocimiento especial a Irene por su apoyo, interés y ayuda a lo largo del proyecto.

Agradezco también a mi tutor, Juan González Vítores, el tiempo y la ayuda prestados para la realización de este trabajo, así como por habilitarlo para que pudiera desarrollarlo.

Así mismo, agradezco a Alberto Valero y a Juan González Gómez su entusiasmo por la docencia y por el proyecto “Mars Challenge”, a través del cual me embarcaron en el mundo de las impresoras 3D y de la robótica.

Por último quiero dar las gracias a mi familia y amigos, por estar siempre ahí cuando se les necesita.

---

## Abstract

The average age of developed countries is increasing and will tend to do so even more in the future. With a growing number of elderly people needing assistance, the demand for aid is rapidly outgrowing the supply available.

In order to reverse this situation, personal robots capable of assisting people both emotionally and physically are being developed. These robots will be able to take care of the elders' needs and being artificial helpers, enough of them can be fabricated to satisfy the demand.

In this project an assistive robot prototype is developed. While being relatively small in size, it is programmed taking into account that the software will eventually be ported to a full-sized robot, and so it has the same capabilities.

The Personal Domestic Service Droid (PD-SD) has a humanoid upper-body attached to a wheeled base. It has two arms with five degrees of freedom each which are used to grab objects or perform actions such as closing doors, while the differential-drive base enables it to maneuver in small spaces since it is capable of rotating in place.

The PD-SD is controlled from an Android phone over a wireless network it creates. The application enables the user to control each of the arm actuators separately or in couples, moving symmetrical motors together. Additional controls include a directional pad to control the base motors, a button for closing or opening the grippers and a button to go back to the initial position. Finally, the top half of the screen is reserved to displaying video received from the on-board camera.

On the robot itself, a Raspberry Pi computer acts as the brains. It enables the wifi network and receives the orders through it, as well as streaming video to the phone. All of the previous is scripted, so it completes the tasks automatically when turned on.

When a connection between Android and Raspberry has been achieved the LCD will display a message informing the user of this, and will do the same when the connection is lost. The data received is sent through serial port to an Arduino microcontroller which will then parse the message and control the different actuators.

---

## Resumen

La edad media de los países desarrollados está aumentando, y tenderá a hacerlo aún más en el futuro. Con un número cada vez más importante de personas mayores con necesidad de asistencia, la demanda de ayuda está sobrepasando rápidamente la oferta disponible.

Para revertir la situación están siendo desarrollados robots capaces de asistir personas tanto emocional como físicamente. Estos robots satisfacen las necesidades de los mayores, y siendo ayudantes artificiales se podrán construir los suficientes para satisfacer la demanda.

En este proyecto se desarrolla un prototipo de robot asistencial. A pesar de su tamaño relativamente pequeño, está programado teniendo en cuenta que el código se portará más adelante a un robot de tamaño humano, y por tanto es capaz de realizar lo mismo.

El Droide de Servicio Doméstico Personal (PD-SD por sus siglas en inglés) tiene un torso con brazos humanoide acoplado a una base con ruedas. Tiene dos brazos, cada uno con cinco grados de libertad que pueden ser utilizados para coger objetos o realizar acciones como cerrar puertas, mientras que la base móvil diferencial le permite maniobrar en espacios pequeños, ya que es capaz de rotar en el sitio.

El PD-SD se controla desde un teléfono con Android a través de una red wifi. La aplicación permite el control individual o por parejas simétricas de los motores de los brazos. Además permite controlar la base mediante un pad direccional, tiene un botón para abrir o cerrar las pinzas y otro para llevar al robot a su posición inicial. Finalmente, la parte superior de la pantalla está reservada para reproducir el vídeo recibido de la cámara de abordo.

En el propio robot un ordenador Raspberry Pi actúa de cerebro. Crea la red wifi a través de la cual recibe las órdenes y retransmite por ella el vídeo. Todo lo anterior está incluido en un script, con lo que se realiza automáticamente al encender el robot.

Cuando se establece una conexión entre el teléfono y el ordenador la pantalla LCD informará de ello mediante un mensaje, y hará lo propio cuando la conexión se cierre. Los datos recibidos se reenviarán mediante el puerto serie a un Arduino, que los parseará y controlará los actuadores pertinentes.

---

## Contents

<b>1</b>	<b>Introduction</b>	<b>1</b>
1.1	Socio-economic factors . . . . .	1
1.2	Proposed solution . . . . .	2
1.3	Scope of the project . . . . .	2
<b>2</b>	<b>State of the art</b>	<b>4</b>
2.1	SAM/Robonaut . . . . .	4
2.2	Asimo . . . . .	6
2.3	RIBA . . . . .	7
<b>3</b>	<b>Project components</b>	<b>8</b>
3.1	3D printer . . . . .	8
3.2	Software . . . . .	9
3.2.1	3D modelling . . . . .	9
3.2.2	G-code generator . . . . .	9
3.2.3	CNC controller . . . . .	10
3.3	Li-Ion battery . . . . .	11
3.4	Voltage level converters . . . . .	11
3.4.1	DC-DC step-down converter . . . . .	11
3.4.2	Bidirectional logic level converter . . . . .	12
3.5	Motors . . . . .	13
3.5.1	DC motor . . . . .	13
3.5.2	Servomotors . . . . .	14
3.6	Arduino . . . . .	16
3.7	Raspberry Pi . . . . .	17
3.8	Android phone . . . . .	19
<b>4</b>	<b>Design alternatives</b>	<b>21</b>
<b>5</b>	<b>Hardware assembly</b>	<b>23</b>
5.1	Assembly . . . . .	23
5.2	Connections . . . . .	34
5.2.1	Electrical connections . . . . .	34
5.2.2	Logic connections . . . . .	37
5.2.3	Software connections . . . . .	38
<b>6</b>	<b>Arduino</b>	<b>39</b>
6.1	Overview . . . . .	39
6.2	Code . . . . .	40
<b>7</b>	<b>Raspberry Pi</b>	<b>42</b>
7.1	Wireless communications . . . . .	42
7.1.1	Existing network . . . . .	42
7.1.2	Ad-Hoc connection . . . . .	42
7.1.3	Wifi Access Point . . . . .	43
7.2	MJPEG Streamer . . . . .	46
7.3	IP/UART Bridge . . . . .	47
7.4	Initializing script . . . . .	49

---

<b>8</b>	<b>Android</b>	<b>50</b>
8.1	Android overview . . . . .	50
8.2	Bot Control . . . . .	52
<b>9</b>	<b>Conclusion</b>	<b>54</b>
9.1	Objectives completion . . . . .	54
9.2	Future work . . . . .	55
	<b>Appendix A Regulatory compliance</b>	<b>59</b>
A.1	Domestic robots regulations . . . . .	59
A.2	MJPG-streamer . . . . .	59
A.3	Hostapd . . . . .	59
A.4	Isc-dhcp-server . . . . .	59
A.5	Gripper model . . . . .	59
A.6	PD-SD . . . . .	59
	<b>Appendix B Project planning</b>	<b>60</b>
	<b>Appendix C Budget</b>	<b>62</b>

---

## List of Figures

1	NASA's Self-propelled Anthropomorphic Manipulator . . . . .	4
2	SAM's control station . . . . .	5
3	Operator controlling the Robonaut coupled to the Centaur . . . . .	5
4	ASIMO pushing a cart . . . . .	6
5	RIBA II carrying a patient . . . . .	7
6	Prusa Air 2 3D printer . . . . .	8
7	SketchUp software . . . . .	9
8	Pronterface CNC control software . . . . .	10
9	Li-ion 12V 6800mAh battery with charger . . . . .	11
10	LM2596S step-down converter . . . . .	12
11	Bidirectional voltage converter . . . . .	13
12	JY-MCU 5V-3V converter . . . . .	13
13	GA25Y370-362 motor . . . . .	14
14	H-bridge circuit . . . . .	14
15	GOTECK GS-551MG servo . . . . .	15
16	TowerPro SG90 servo . . . . .	15
17	Arduino Nano v3 . . . . .	16
18	Raspberry Pi model B . . . . .	17
19	Raspberry Pi peripherals . . . . .	18
20	Smartphone market share . . . . .	19
21	Haipai Noble H868 . . . . .	20
22	First sketch of the PD-SD . . . . .	21
23	Initial arm design . . . . .	22
24	Final design of the arm . . . . .	22
25	Assembly of the gripper . . . . .	23
26	Detail of the gripper assembled . . . . .	24
27	Connection of the gripper to the forearm . . . . .	24
28	Detail of elbow assembly . . . . .	25
29	Linkage of the elbow to the forearm . . . . .	25
30	Detail of upper arm assembly . . . . .	26
31	Coupling of the upper arm to the elbow . . . . .	26
32	Detail of bearings insertion into the upper arm . . . . .	27
33	Detail of shoulder assembly . . . . .	27
34	Coupling between arm and shoulder . . . . .	28
35	Detail of linkage between the shoulder servo and the upper arm . . . . .	28
36	Detail of velcro stripes used to secure the Raspberry Pi . . . . .	29
37	Detail of velcro stripe used to secure the camera . . . . .	29
38	Coupling of the electronics to the robot's head . . . . .	29
39	Assembly of the upper body . . . . .	30
40	Detail of support rods insertion . . . . .	30
41	Detail of base assembly . . . . .	31
42	Connection of upper body to base . . . . .	31
43	Detail of velcro stripes in the base . . . . .	32
44	Detail of velcro stripes in the battery(L) and circuit board(R) . . . . .	32
45	Assembled robot . . . . .	33
46	Detail of the robot's actuators . . . . .	33
47	Electrical connections diagram . . . . .	35

---

48	Detail of LCD and Serial connections . . . . .	36
49	Detail of motor driver wiring . . . . .	36
50	Table with the arduino pins assigned to each element . . . . .	37
51	Logic connections diagram . . . . .	38
52	Software connections diagram . . . . .	38
53	Arduino code skeleton . . . . .	39
54	Arduino program flowchart . . . . .	41
55	Wifi Access Point connection configuration . . . . .	44
56	IP/UART program flowchart . . . . .	48
57	Android app activity lifecycle . . . . .	51
58	Bot Control application . . . . .	52
59	Detail of the "Activity running" state . . . . .	53
60	Vacuum gripper . . . . .	55
61	Creative Commons Attribution logo . . . . .	59
62	Duration of each phase of the project . . . . .	60
63	Gantt diagram specifying the duration of each of the project's objectives . . . . .	61



---

## Listings

1	Ad-Hoc Configuration [ /etc/network/interfaces ] . . . . .	43
2	DHCP Server Configuration [ /etc/dhcp/dhcpd.conf ] . . . . .	43
3	DHCP Server Configuration [ /etc/dhcp/dhcpd.conf ] . . . . .	44
4	DHCP Server Defaults [ /etc/default/isc-dhcp-server ] . . . . .	45
5	Interface Configuration [ /etc/dnetwork/interfaces ] . . . . .	45
6	AP Configuration [ /etc/hostapd/hostapd.conf ] . . . . .	46
7	AP Defaults [ /etc/default/hostapd ] . . . . .	46
8	Streaming Initialization Script [ startStreaming.sh ] . . . . .	47
9	Initialization Script [ /etc/rc.local ] . . . . .	49

---

# 1 Introduction

The Merriam-Webster dictionary defines a robot as “a machine that can do the work of a person and that works automatically or is controlled by a computer”. From the purely mechanical Renaissance automata, like the walking and praying monk in the Smithsonian Institute’s collection[1] to the state of the art ASIMO, referenced in the following chapter, robots have always spurred the collective imagination and enthusiasm of their builders.

From the mid-twentieth century the robot universe has vastly expanded, and they are now present in almost every field, ranging from construction[2] to space[3] or medicine[4]. However, a new type of robot is beginning to appear: the domestic robot. This can be either purely social, limited to interacting and connecting emotionally with people[5] or assistive, designed to carry out tasks a person needs help with[6].

Until now, most assistive robots were limited to specific tasks, like helping with feeding or transporting people. This project however intends to build a general purpose assistive robot, that users can telecontrol from their phones and later on program simple routines to be repeated at a certain frequency.

## 1.1 Socio-economic factors

Developed countries’ populations are ageing. With improved health systems the average life expectancies are getting higher. In Spain this situation is even more noticeable, since in a study by realized by the World Health Organization (WHO) [7] it is shown that Spaniard women have the highest life expectancy in Europe and the second highest in the world, only behind Japan.

While increasing life expectancies is a victory for individuals, combined with lowering birth rates results in average population age increments. This means that there will be more elder people depending on the younger generations and not enough of the latter to help them in daily activities. With the actual trend of continuously increasing life expectancies in Europe [8], the situation in those countries will be even more pronounced.

One solution may be to include social, domestic robots that would assist with domestic chores. The proposed solution tries to tackle this problem by doing exactly that: a low cost robot that anybody can buy or build and improve as needed.

The components are chosen taking into account reach and cost. The controller is an Android smartphone, since up to 66 percent of the population in Spain owns a smartphone[9], and out of those around 85 percent are Android[10]. Android phones also come in all prices, so users without a phone can buy the least expensive models and still be able to use the robot.

The on-board electronic brains, a computer and a microcontroller board are a Raspberry Pi and an Arduino respectively. These have been chosen for their capabilities, but especially for their price tags: the former costs 40€and the second 23€, far below the 300€price line most “cheap” computers cost.

Finally, the robot parts are 3D printed, since that is much more cost-efficient in small batches than mold injection, especially for an evolving product like a robot improved by the user community.

---

## 1.2 Proposed solution

The proposed solution is the creation of a Personal Domestic Service Droid (PD-SD), a robot with a humanoid upper body on a wheeled base that will be capable of assisting elderly people or with physical disabilities. While the final robot should be of full human-size, to be able to lower high objects, a smaller prototype will be presented in this project. This is done to keep the focus on the software, which is identical and can be exported directly to a full-size robot when it is perfected, while creating a scale model to use while improving the programs.

The PD-SD is controlled from the user's Android smartphone, which will connect to the robot's wifi network to control it. The latter will also stream video from its camera to the smartphone, while obeying the instructions given from the Android application. It has two arms with 5 degrees of freedom each to be able to grasp objects or perform simple actions such as closing doors, and a differential-drive base to move throughout space while being able to rotate in place, which may be useful to avoid getting stuck in small spaces such as corridors.

## 1.3 Scope of the project

This project's ultimate objective is to build a robotic assistant prototype, which may be controlled by a user from their own smartphone and which will stream a video feed from its camera so the user is able to see through the robot. This prototype is built to develop the technology that can be later used in a full-scale robot capable of assisting elderly people or with disabilities.

In order to achieve this result, the project is divided into the following objectives:

- I. Study of different robot configurations to find the optimal choice for domestic assistive activities.
- II. Design of the aforementioned robot.
- III. Creation of the designed parts with a 3D printer.
- IV. Assembly of the robot's body and installation of the electronic components.
- V. Program the microcontroller to understand the user's commands and control the actuators accordingly.
- VI. Program the onboard computer to:
  - i. set up a wifi network to communicate with the user
  - ii. stream video from the attached camera
  - iii. send the user's commands to the microcontroller.
  - iv. do all of the previous automatically when the system boots.

---

VII. Program the Android application the user will use to control the robot and receive the video feed it streams.

---

## 2 State of the art

Robots that interact with humans have been developed since the mid-twentieth century. Here is a list of some of the most relevant robots to the field of application of the PD-SD built to date.

### 2.1 SAM/Robonaut

Built in 1969, the Self-propelled Anthropomorphic Manipulator (SAM), seen in Figure 1, was NASA's first radio teleoperated robot [11]. It was composed of two distinct parts: the manipulator and the control center.

The manipulator consisted of a torso with two arms and a camera attached to a four wheeled base. The robot sent video feed from the camera over a radio to the operator which would receive the video on a television set.

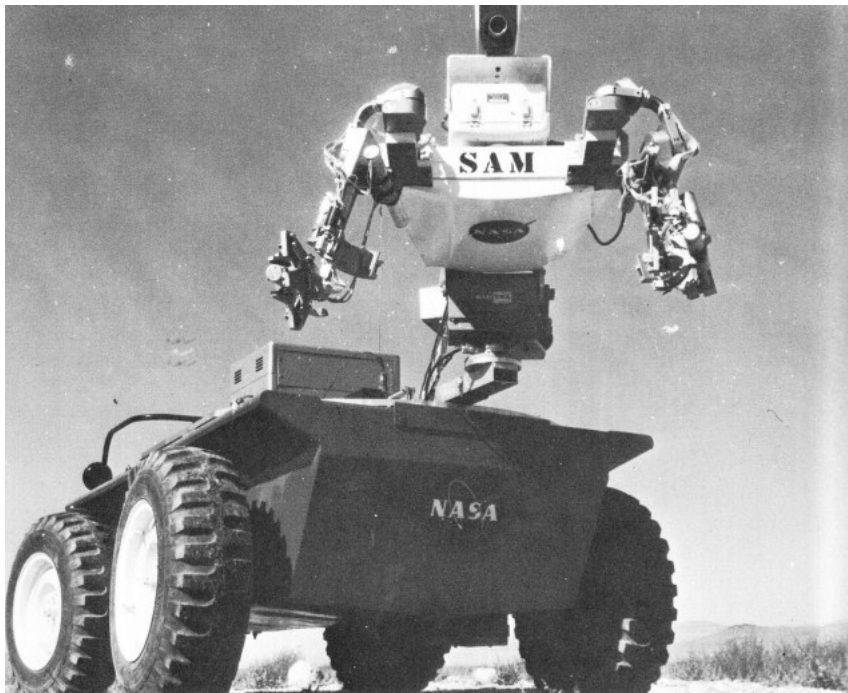

Figure 1: NASA's Self-propelled Anthropomorphic Manipulator

The control station, as seen in Figure 2, included an upper-body exoskeleton through which the operator could move their arms and have the robot replicate the movements and the screen through which the robot displayed the video stream.



Figure 2: SAM's control station

In the year 1997 NASA started developing Robonaut, a telepresence robot that would assist astronauts in tasks too dangerous or mundane for them to work on[12] [13]. The combination of the four wheeled base Centaur with Robonaut creates a powerful, efficient, fast successor of the original SAM, while providing a much smaller, portable control station (Figure 3).



Figure 3: Operator controlling the Robonaut coupled to the Centaur

---

## 2.2 Asimo

Introduced in the year 2000, Honda's Advanced Step in Innovative MObility (ASIMO) is a humanoid robot designed to assist humans in daily tasks [14]. Its height of 130cm ensures it is able to operate door handles and light switches. Capable of recognizing voice commands and common gestures such as pointing or waving as well as different human faces, the robot is capable of facing and interacting with whoever is speaking[15].



Figure 4: ASIMO pushing a cart

Some of its additional abilities include navigating space while avoiding oncoming people, carrying or pushing objects (Figure 4), using the stairs, playing sports such as soccer and heading towards its charging station whenever it detects its battery charge level is low.[16]

---

### 2.3 RIBA

The Robot for Interactive Body Assistance (RIBA) was developed in conjunction between RIKEN and Tokai Rubber Industries in the year 2004 to provide assistance in human handling, such as setting a person into their wheelchair or transporting them to their bed.[17]

The first RIBA, from 2009, could lift around 60kg, while the new RIBA II from 2011 is able to carry up to 80kg, which would cover most of Japan's population, the average adult weighing around 60kg.[18][19]



Figure 5: RIBA II carrying a patient

Its 140cm height ensures it is able to lift people to the highest beds, while its 180kg provides a solid counterweight to avoid toppling over when carrying a person.



---

### 3 Project components

This section will explain the different tools and components used for the creation of the project.

#### 3.1 3D printer

3D printers are Computer Numerical Control (CNC) machines that are capable of transforming virtual 3D models created with a Computer Aided Design (CAD) software into real-world objects.

Created in 1984 by Chuck Hull of 3D Systems Corp this technology was little-known to the general public and was mainly used in industries for short runs of difficult pieces.

In 2005 Dr. Adrian Bowyer, from the University of Bath, UK, started the RepRap project[20]. Its goal was “to produce a pure self-replicating device not for its own sake, but rather to put in the hands of individuals anywhere on the planet, for a minimal outlay of capital, a desktop manufacturing system that would enable the individual to manufacture many of the artifacts used in everyday life” [21]

Today a vast range of 3D printers co-exist, varying in size, price and materials used.

In this theses a RepRap Prusa Air 2 (Figure 6) model is used. It is of a “fused filament fabrication additive manufacturing” type. This type of printers extrude mainly ABS or PLA plastics, and deposit new liquified material over their previous layer, now solid, effectively building parts from the bottom up layer by layer.

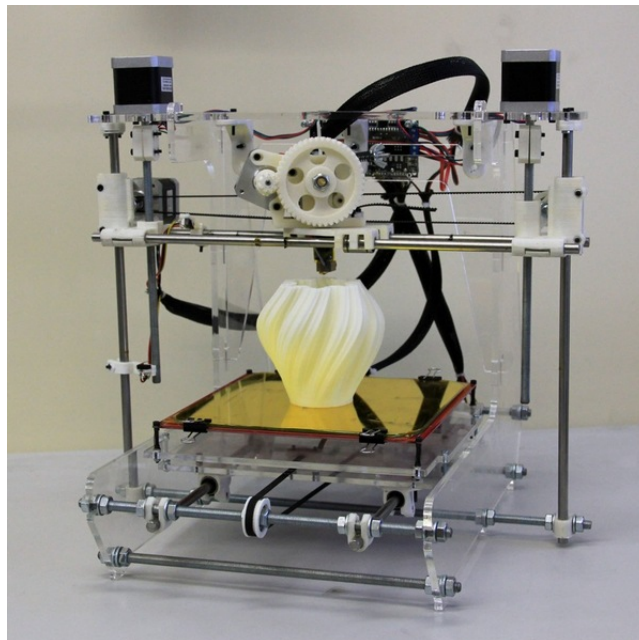

Figure 6: Prusa Air 2 3D printer

---

## 3.2 Software

This type of 3D printers work by turning 3D models into plastic parts. These models are first modelled in a CAD program and then processed with a *slicing* software to divide the model into layers of G-code, which is the standard language interpreted by CNCs. This is then introduced into the printer to build the part.

### 3.2.1 3D modelling

In this project SketchUp has been used to create the printed parts. Owned by the company Trimble Navigation it is a WYSIWYG (What You See Is What You Get) modelling editor with a large online warehouse of parts available for download. Figure 7 shows the program's user interface.

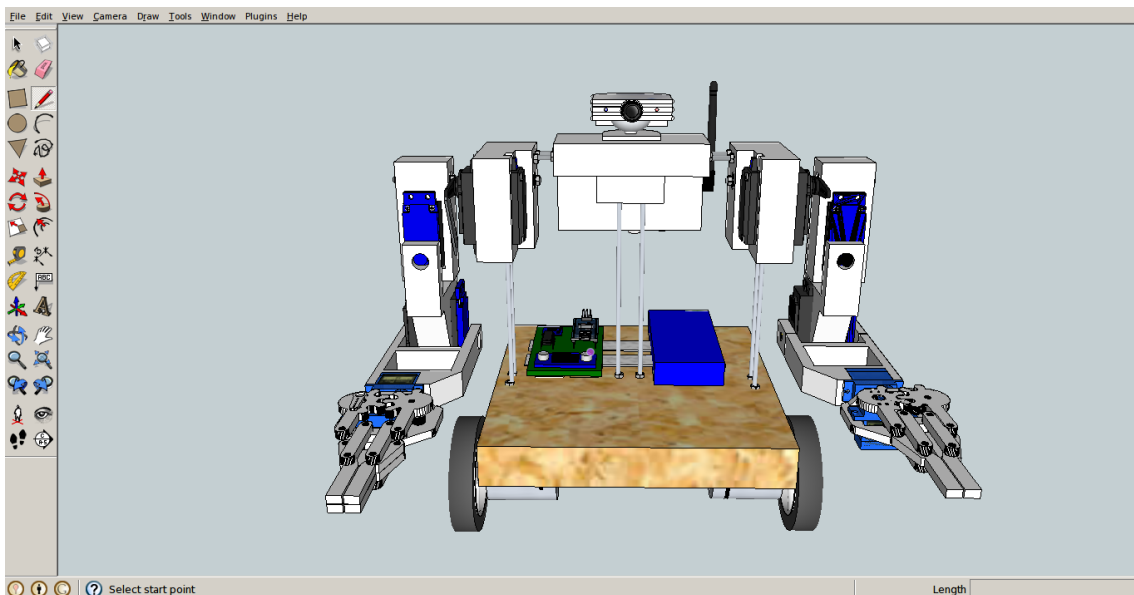

Figure 7: SketchUp software

In order to make it compatible with the slicing software, SketchUp's proprietary format, *SKP*, has to be converted to the standard *STL*. In order to accomplish this the *Su2stl.rb* plugin is installed. A new *Plugins* menu appears in Sketchup which contains the Import/Export options, where the desired output format and model units are specified.

### 3.2.2 G-code generator

Once the model is converted to *STL* it then has to be sliced. Since 3D printers work by building layer upon layer of plastic, the model has to be transformed into the same format. The G-code generator converts the CAD model into layers of CNC instructions. There are three main slicing programs, each with their own benefits:

- Skeinforge:  
The first slicing program used in homemade 3D printers. It is by far the most complete of the three. It allows the user to control each and every imaginable setting of the printer, from the axis' speeds to the retraction distance of the plastic into the extruder

---

while moving. However, because of this it has a very steep learning curve which makes it unsuitable for the average consumer.

- Slic3r:  
Slic3r was created as an user-friendly software, which only gives the final user a choice in the basic settings, such as printing speeds, filament widths or part infills. As a result it is an easier program to slice parts with a sufficient level of customization. It has nonetheless problems converting models with imperfections or broken shapes.
- Cura:  
Finally, Cura is also designed with user-friendliness in mind. This slicer is more robust than Slic3r, in that it will accept models with imperfections, and will try to correct them. It also features a box simulating the print area in which the model can be moved around, turned or scaled before printing. This last feature is specially useful if minor changes need to be made, without returning to the CAD software.

To print the needed parts Cura was chosen because of its simplicity and usefulness in rearranging the objects without having to modify the original CAD files.

### 3.2.3 CNC controller

Finally once the G-code is created it is passed on to a CNC controller which will feed all the code's commands to the printer. The chosen software, Pronterface (Figure 8), allows the user to control the movement of the printer's axes, including the extruder, as well as the temperature settings or the calibration procedure.

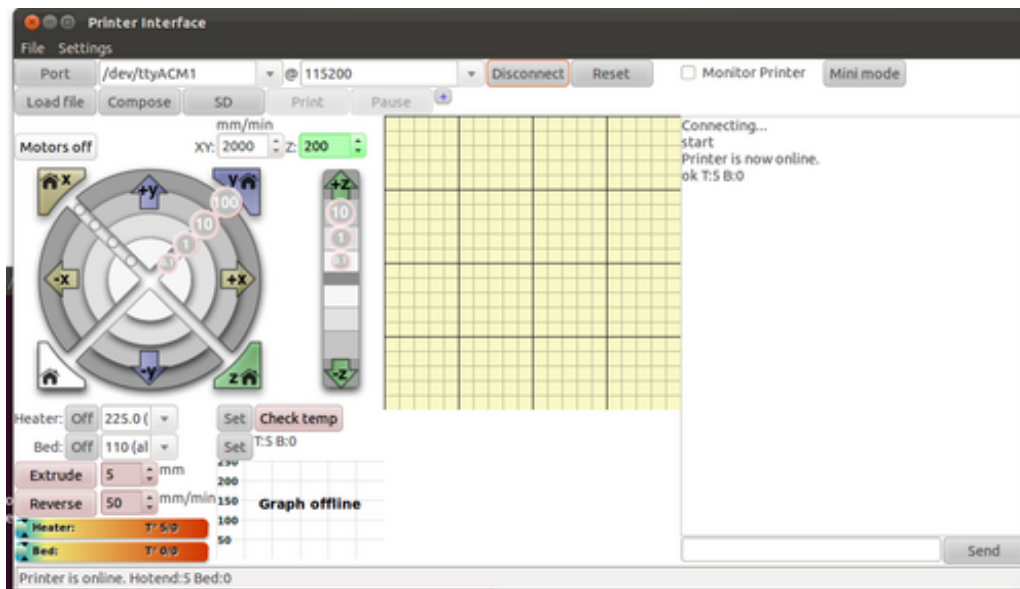

Figure 8: Pronterface CNC control software

---

### 3.3 Li-Ion battery

The whole system is powered by a lithium ion 12V 6800mAh battery as seen in Figure 9. This was chosen because of the high voltage and durability it delivers over regular AA batteries[23].



Figure 9: Li-ion 12V 6800mAh battery with charger

### 3.4 Voltage level converters

Different electronics demand different power levels, ranging from 3.3V up to 12V in this case. In order to provide suitable voltages to each part, different voltage level converters are used.

#### 3.4.1 DC-DC step-down converter

Voltage level converters are used to adapt a source's voltage to that required by the load. In this thesis a DC-DC converter is used to decrease the 12V given by the battery to the 5V required by the logic components as well as the servomotors.

The simplest method would be to use a linear regulator such as a 7805, which is a cheap, single-component solution[23]. However, this is greatly inefficient solution, since a great part of the power is dissipated as heat. For instance, if a 7805 were to be used in this project, about  $\frac{Power_{in}-Power_{out}}{Power_{in}} = \frac{12 \cdot I - 5 \cdot I}{12 \cdot I} = \frac{12-5}{12} = 58.33\%$  of the power is wasted.

A much more efficient solution is to use a switching regulator such as a Buck converter, which has an efficiency level of around 95% [24][25]. Buck converters work by switching rapidly between “On” and “Off” states, which sets the output voltage in function of the duty cycle  $d = \frac{time_{on}}{time_{on}+time_{off}}$ . The converter (Figure 10) used includes a potentiometer to set the output level by selecting the duty cycle.

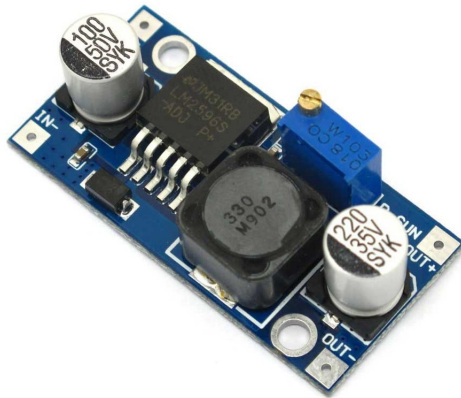

Figure 10: LM2596S step-down converter

The converter's electrical specifications are:

- Adjustable input voltage: 3.2 - 40V
- Adjustable output voltage: 1.25 - 35V ( $V_{in} > V_{out} + 1.5V$ )
- Max. output current: 3A

### 3.4.2 Bidirectional logic level converter

In order to enable serial communication between the Arduino and the Raspberry Pi another voltage level converter must be introduced, since the former operates at a 5V level while the latter does so at a 3.3V level.

In this case a switching regulator like the previous one will not work because the communications are much faster than the regulator's switching speed. Therefore a bidirectional, low power converter can be built out of transistors.

Figure 11 shows a simple converter model. Analyzing the circuit from the low side:

- If a logic one is emitted, the transistor source pin is grounded and it switches on, pulling down the high side to zero.
- If a logic zero is sent, the transistor is tied high and so is off, leaving the high pin connected to the pull-up resistor and thus seeing a one.

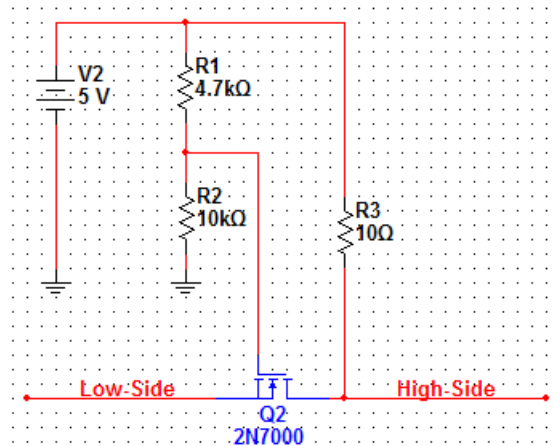

Figure 11: Bidirectional voltage converter

This setup works for one line, two identical circuits are needed in order to provide for serial communication. For this project a commercial board (Figure 12) is used to reduce the total size of the converter by using SMD components.



Figure 12: JY-MCU 5V-3V converter

This board is used with UART communication, but is equally adequate for I<sup>2</sup>C, SPI or one-wire communication.

### 3.5 Motors

Three different types of actuators are present in the robot, which are either continuous motors or servomotors.

#### 3.5.1 DC motor

DC motors are simple actuators that start spinning whenever there is a voltage applied between their wires. Their speed is directly dependent of the voltage level applied, and the turning sense on the polarity of the connection.

This robot uses two GA25Y370-362 dc motors (Figure 13), which turn at a 10rpm with a torque of 5Nm when connected to a 12V source.



Figure 13: GA25Y370-362 motor

Since the motor only has two wires, a controller is needed to interface it to the arduino. This type of controller is called an H-bridge because of its circuit topology (Figure 14). It consists of a series of transistors that can be opened or closed to reverse the polarity of the motor, as well as to apply a PWM modulation to control its speed.

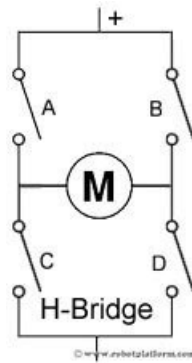

Figure 14: H-bridge circuit

In this case a L293D chip with two internal H-bridge circuits is used to control both motors.

### 3.5.2 Servomotors

On the other hand, servomotors are much more complex than continuous motors. These consist of a regular dc motor, a set of gears, an internal potentiometer and a control circuit. They also do not revolve continuously but rather oscillate in a range of approximately  $180^\circ$ .

In order to control the servo the user gives the desired position through the input cable and the circuit board matches it to a resistance value. The motor then starts turning which does the same to the potentiometer, and stops when the latter reads the desired resistance value.[26]

The robot uses three GOTECK GS-551MG (Figure 15) servos per arm, which are used for the more demanding movements, while it employs two additional TowerPro SG90 (Figure 16) servos for the less challenging actions of wrist rotation and gripper manipulation.



Figure 15: GOTECK GS-551MG servo

The GOTECK's technical specifications are:

- Operating voltage: 4.8 V
- Maximum torque: 1.3 Nm
- Speed: 0.20sec/60deg



Figure 16: TowerPro SG90 servo

The TowerPro's technical specifications are:

- Operating voltage: 4.8 V
- Maximum torque: 0.18 Nm
- Speed: 0.10sec/60deg



---

### 3.6 Arduino

Arduino is a family of low-cost electronic boards designed to be easily programmable. From the official Arduino website, “Arduino is an open-source electronics prototyping platform based on flexible, easy-to-use hardware and software. ”[27]

Arduino is programmed using its own language, which is merely a set of C/C++ functions compiled with *avr-g++*. They can nonetheless be programmed in pure C or C++ in an external IDE and have code uploaded to it as any other AVR board.

In this project an Arduino Nano v3 with an ATmega 328 microcontroller has been chosen mainly due to its processing power and reduced size.[28]

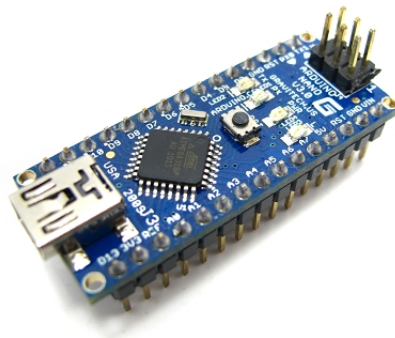

Figure 17: Arduino Nano v3

The official Arduino Nano V3 specifications are:

- **Microcontroller:** Atmel ATmega168 or ATmega 328
- **Operating Voltage (logic level):** 5V
- **Input Voltage (recommended):** 7-12V
- **Input Voltage (limits):** 6-20V
- **Digital I/O Pins:** 14 (of which 6 provide PWM output)
- **Analog Input Pins:** 8
- **DC Current per I/O Pin:** 40mA
- **Flash Memory:** 16 KB (ATmega168) or 32 KB (ATmega328), of which 2 KB used by bootloader
- **SRAM:** 1 KB (ATmega168) or 2 KB (ATmega328)
- **EEPROM:** 512 bytes (ATmega168) or 1 KB (ATmega328)
- **Clock Speed:** 16MHz
- **Dimensions:** 0.73” x 1.70”
- **Communications:** UART, SPI and I<sup>2</sup>C buses

---

### 3.7 Raspberry Pi

From the official website of the homonymous foundation, the Raspberry Pi is a “credit-card sized computer that plugs into your TV and a keyboard. It is a capable little computer which can be used in electronics projects.” [29]



Figure 18: Raspberry Pi model B

Available in two models, A and B, the Raspberry has a Broadcom BCM2835 System On a Chip, which includes an ARM1176JZF-S 700MHz processor and a VideoCore IV GPU. It includes as well a 256Mb RAM, upgraded to 512Mb in model B.[30]

The Pi features:

- HDMI, composite and raw DSI video outputs
- 3.5mm audio jack
- SD card socket
- Low-level peripheral connections including:
  - 8 General Purpose Input Output (GPIO) pins
  - Universal Asynchronous Receiver Transmitter (UART) bus
  - Inter-Integrated Circuit (I<sup>2</sup>C) bus
  - 2 Serial Peripheral Interface (SPI) buses
  - Power pins: 3.3V, 5V and GND
- Ethernet socket
- USB hub (1 socket in model A, 2 in model B)

---

The main storage unit is the SD card, and that is where the OS is flashed, normally a Linux distribution. The most popular is Raspbian, an adapted version of Debian Wheezy, although other Linux distros or even other OS like Android or XBMC can be used.



(a) WiFi USB dongle



(b) PlayStation 2 EyeToy



(c) LCD screen 16x2

Figure 19: Raspberry Pi peripherals

In this project a Raspberry Pi model B running Raspbian manages the software side of the robot. It has an Ralink Technologies RT5730 WiFi USB dongle , a PlayStation 2 EyeToy USB camera and a 16x2 character LCD screen connected in order to create a WIFI Access Point, stream video to the user and signal its status respectively.

### 3.8 Android phone

Android is one of the most popular operating systems for smartphones. Created in 2003 by the eponymous company and acquired by Google Inc. two years later, its open-source nature has incentivised manufacturers to include it in their products, expanding its reach until it has dominated the market share, as seen in Figure 20 [31].

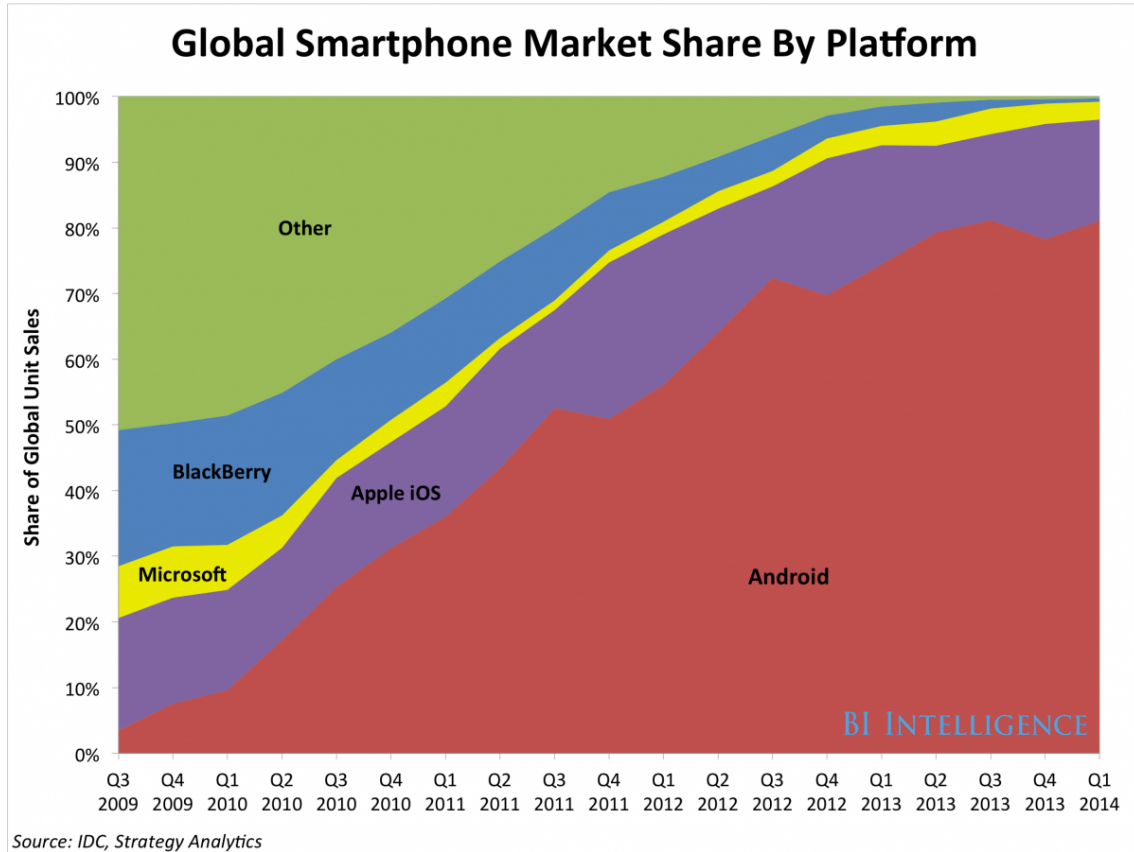

Figure 20: Smartphone market share

Android has been chosen for the following reasons:

- **Market share:** Being the operating system used by the highest number of people means that the robot will be useful to the largest amount of users possible.
- **Price ranges:** Because most mobile phone manufacturers nowadays include Android each user will be able to enjoy the product without having to pay for a high-end phone.
- **App development:** Finally, Android apps such as Bot Control can be programmed from any computer regardless of the OS, and can be uploaded to the user's phone directly. This means users are able to customize the app with no extra costs, such as having to use a certain OS and paying a developer's fee.

---

In this project a Haipai Noble H686 (Figure 21) is used. Some of its more relevant specifications are:

- **CPU:** Quad-Core Mediatek MTK6589 1.2GHz
- **RAM:** 1 GB
- **OS:** Android 4.2 Jelly Bean
- **Screen Size:** 6.0 inches



Figure 21: Haipai Noble H686

---

## 4 Design alternatives

Before arriving to its final form, several designs for the PD-SD were considered. Here are listed the various alternatives weighed:

**Humanoid** The most natural form an assistive robot can take to replace a person in home chores is that of another, since homes are designed to be controlled and navigated by humans.

Therefore a humanoid robot was the immediate answer: its degrees of freedom would enable it to carry out the same tasks as their human counterparts, it would have the right size to be able to handle objects placed in high furniture and it would have a form that would generate an emotional response from the user.

However, the humanoid has one major disadvantage, control. While two-legged robots do exist, as seen previously with Honda's ASIMO, they are very unstable and require active control algorithms to balance it.

To make the droid stable even when unpowered and to simplify the algorithms the legs were replaced by a wheeled base. This also had the side effect of reducing the cost, since each wheel would be driven by one motor to provide a differential drive, instead of a total of twelve motors for a pair of full human like legs, with three to simulate the hip joint, one for the knee and two more for the ankle, per leg.

**Four wheels** The first wheeled base design envisaged four wheels in order to keep it stable, each with its own motor. However, the design is redundant, as a two-wheeled base with a caster at the rear end is equally stable but reduces the number of active wheels. This decreases the price, the power consumption, frees up two pins on the micro controller and reduces the length of the code, while remaining suitable to support the robot.

**Exoskeleton** One of the first designs is shown in Figure 22. It featured a robot with an exoskeleton and a central beam. This version granted different levels into which the various components could be placed while hiding the cables inside.

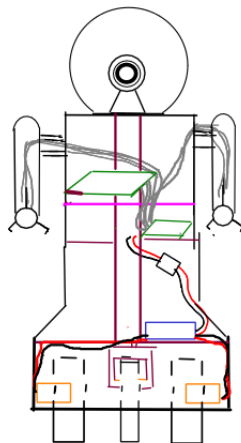

Figure 22: First sketch of the PD-SD

---

However, it provided very little stability and a design with a more human-like skeleton was chosen.

**Arm designs** The most natural configuration for the robot to grasp objects would be that of a human hand, especially taking into account that most objects are designed to be handled it.

However, in the final design a parallel gripper was chosen because it reduced the number of motors needed to one per gripper, while having two parallel-closing fingers capable of gripping objects of differing sizes.

The first CAD model of the arm is shown in Figure 23. It included five motors, four directional and one to control the gripping action. The orientation of the servomotors ensured rotation in all three axes, with two degrees of freedom in the pitch angle. This is done to give the possibility of linear movement useful for lifting and lowering objects in cluttered spaces.

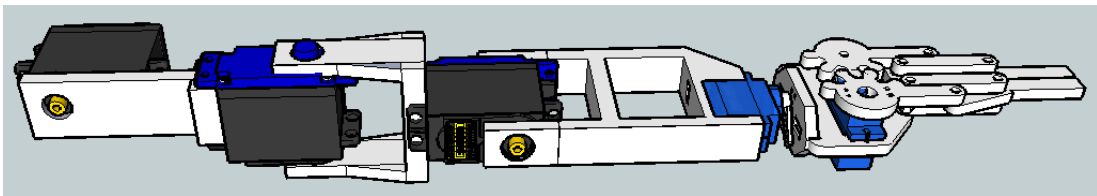

Figure 23: Initial arm design

In Figure 24 the final design is shown. While it keeps the original servo orientation, the placement is modified to reduce the distance between the two leftmost motors and so reduce the torque needed to lift objects.

The plastic parts have also been modified to enclose the motors, which now are firmly secured in place, and to support the weight of the arm instead of relying in the screws to do so.

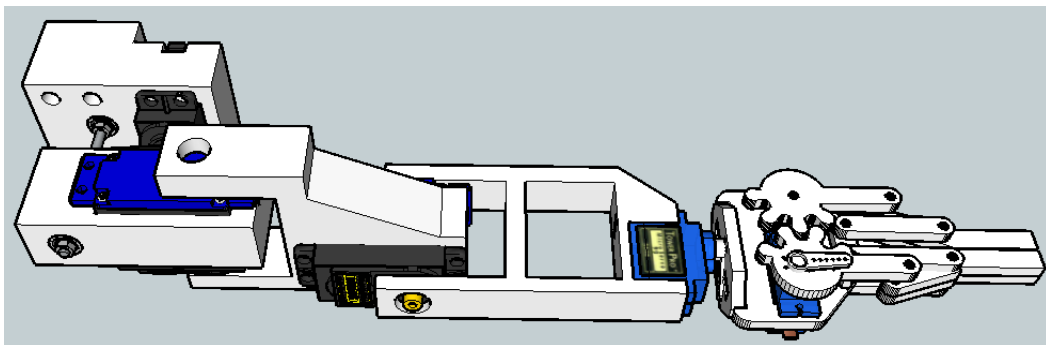

Figure 24: Final design of the arm

---

## 5 Hardware assembly

### 5.1 Assembly

This section will cover how to put together all the individual pieces that compose the robot in a step-by-step guide.

The first part to be assembled is the one with the greatest number of pieces, the gripper. This was designed by Thingiverse user “habo”<sup>1</sup>, and is used because of its parallel way of closing, which guarantees a good grip at any degree of aperture. In order to build it, the corresponding lettered holes simply have to be connected, as shown in Figure 25. These must be fastened together with M3x25mm screws, except for hole “A” and the wrist servo, which are fastened with the bolts included with the servos.

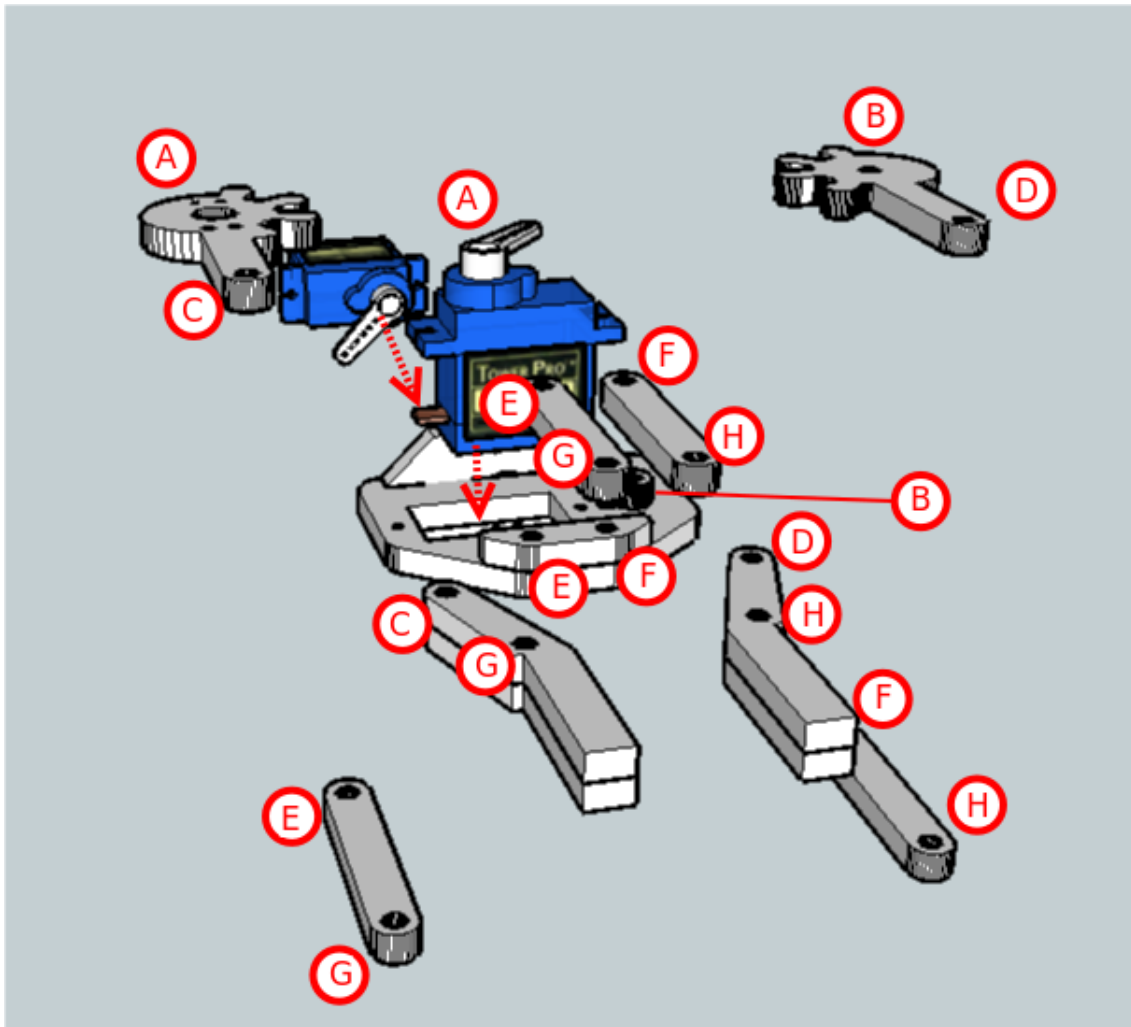

Figure 25: Assembly of the gripper

The end result can be seen in Figure 26, which can also be used for reference during assembly.

---

<sup>1</sup><http://www.thingiverse.com/thing:5735>



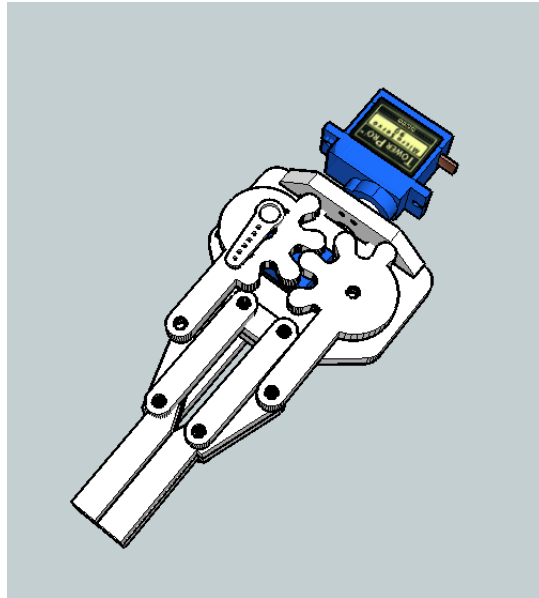

Figure 26: Detail of the gripper assembled

The next step is to attach the forearm to the gripper. This is done by snapping the wrist servo into its socket and securing it in place with screws.

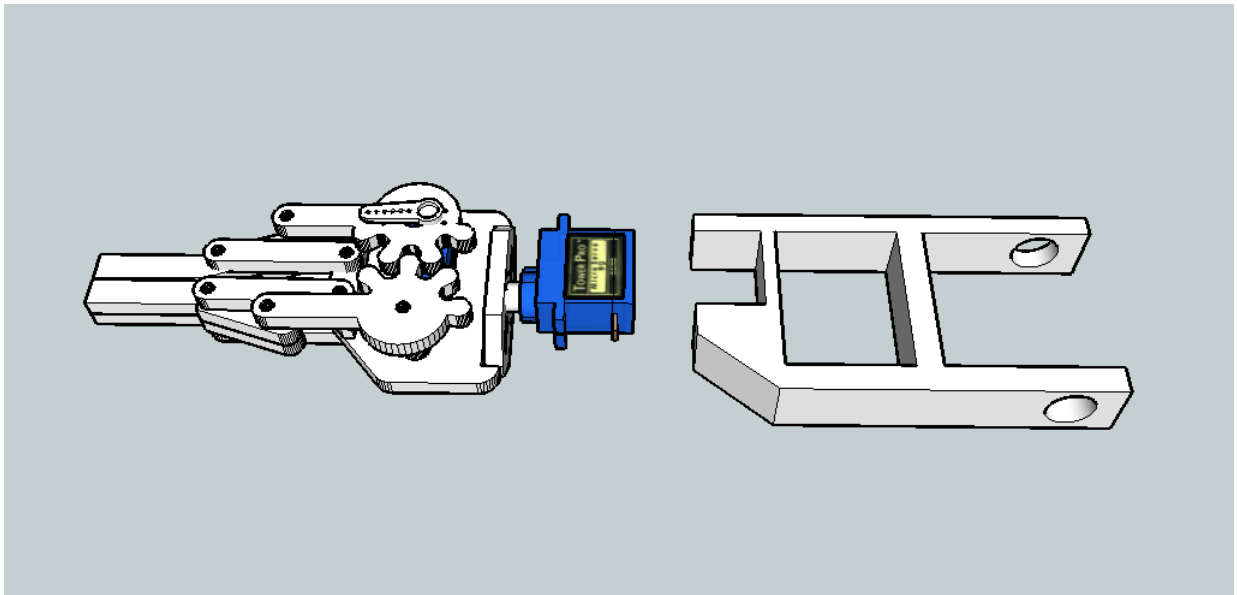

Figure 27: Connection of the gripper to the forearm

Once the gripper and forearm are attached, the elbow needs to be assembled (Figure 28). This is done by introducing one of the Goteck servos through the hole and screwing a shafted lid designed by “Obijuan”<sup>2</sup>.

---

<sup>2</sup><http://www.thingiverse.com/thing:89810>

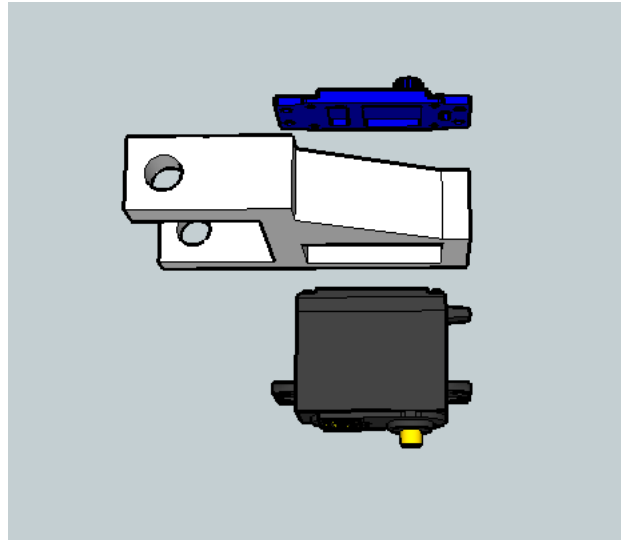

Figure 28: Detail of elbow assembly

Figure 29 shows how the elbow is snapped into the rear of the forearm, by bending slightly the latter's prongs.

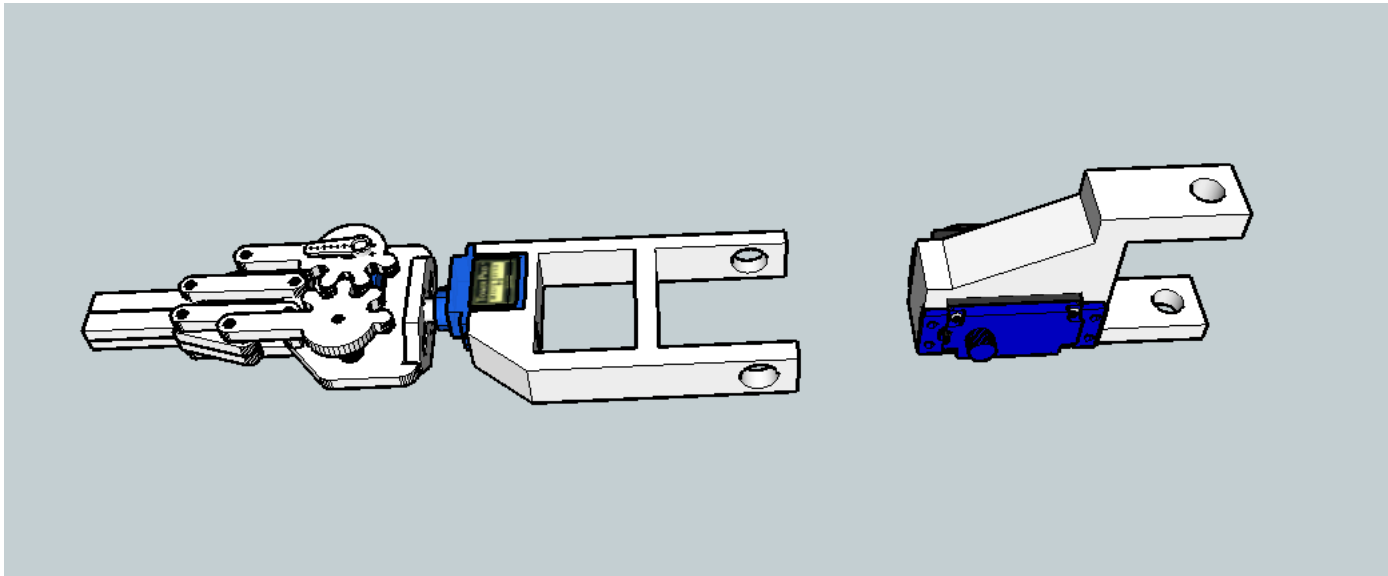

Figure 29: Linkage of the elbow to the forearm

The upper arm module is fitted with a Futaba servo in the same fashion as the elbow (Figure 30) and then fitted into the elbow piece in the same manner as the previous unit (Figure 31).

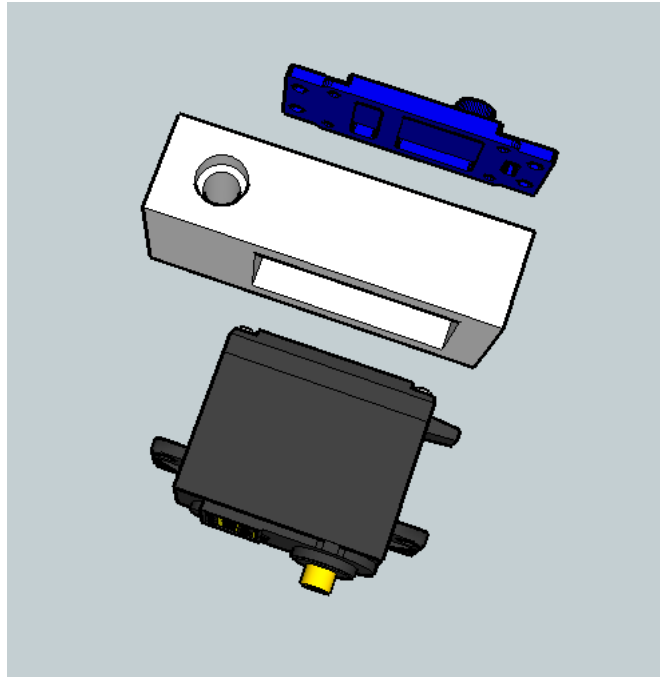

Figure 30: Detail of upper arm assembly

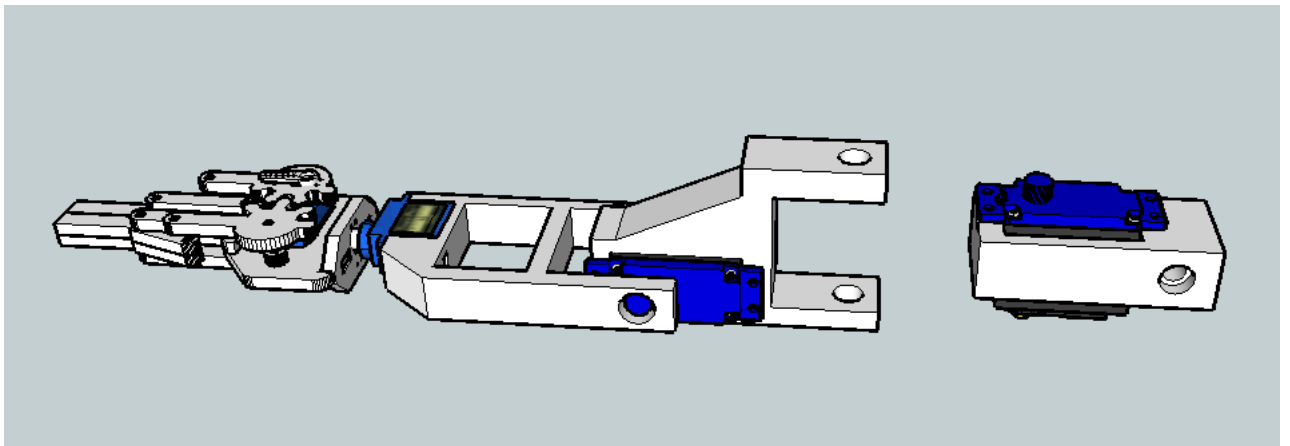

Figure 31: Coupling of the upper arm to the elbow

Next, two 623ZZ bearings are placed each into the upper arm (Figure 32) and shoulder (Figure 33) modules. The latter also has a Goteck servo inserted in place.

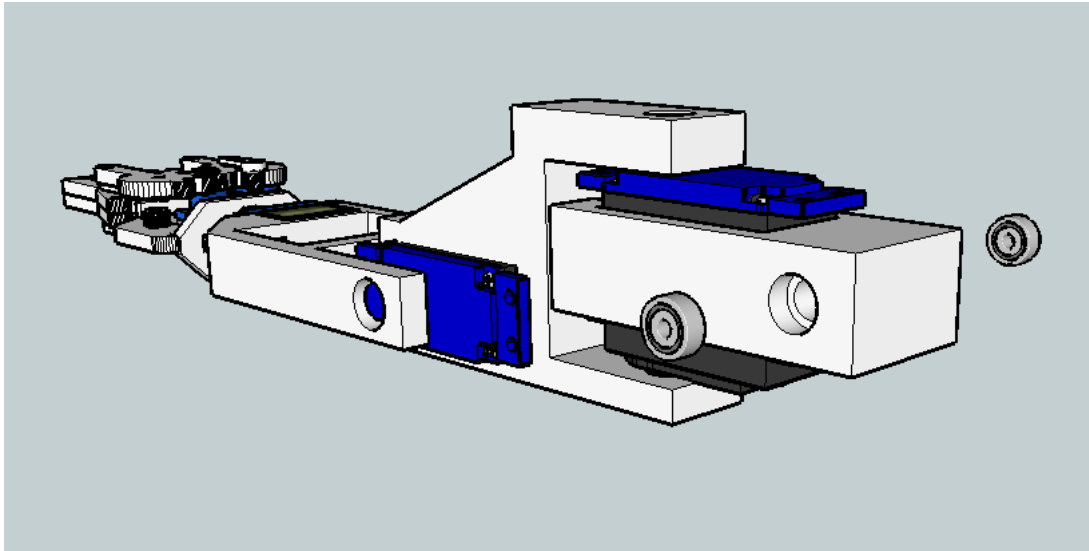

Figure 32: Detail of bearings insertion into the upper arm

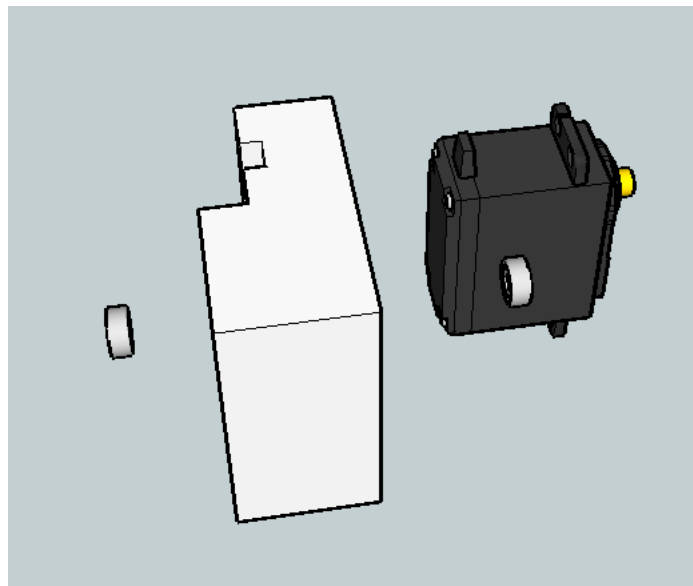

Figure 33: Detail of shoulder assembly

The completed arm is linked to the shoulder part through a M3x120mm threaded rod and secured in place with four M3 nuts, which will avoid lateral displacement (Figure 34). This is done to discharge the servomotor from the arm's weight, so it only needs to provide torque for turning, but not have to support the load.

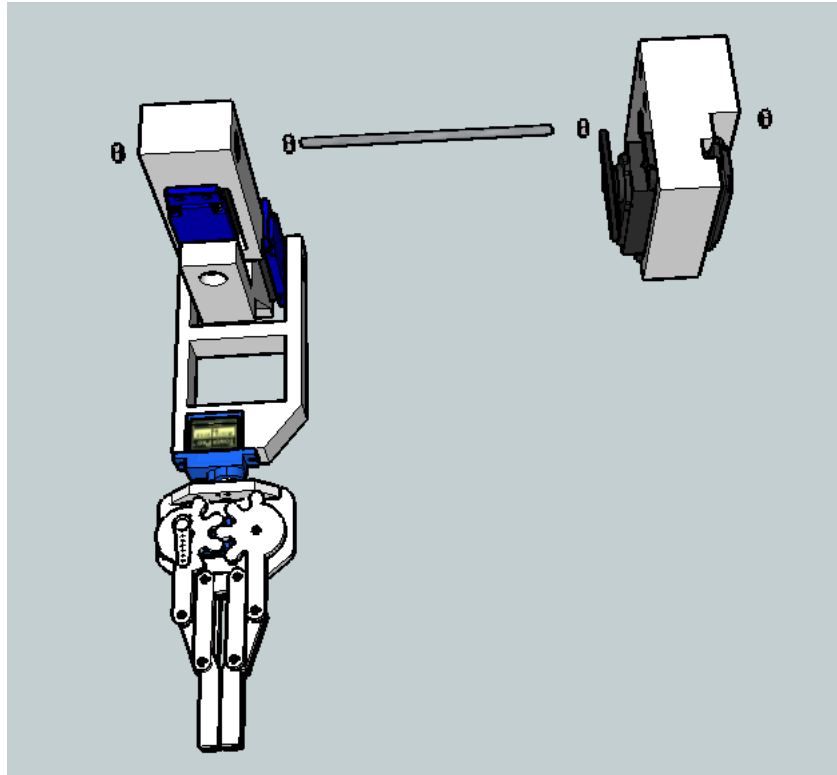

Figure 34: Coupling between arm and shoulder

Figure 35 shows the mechanical linkage between the servo and the upper arm module, which is able to rotate freely at both ends, providing traction to move the arm around the shoulder axis.

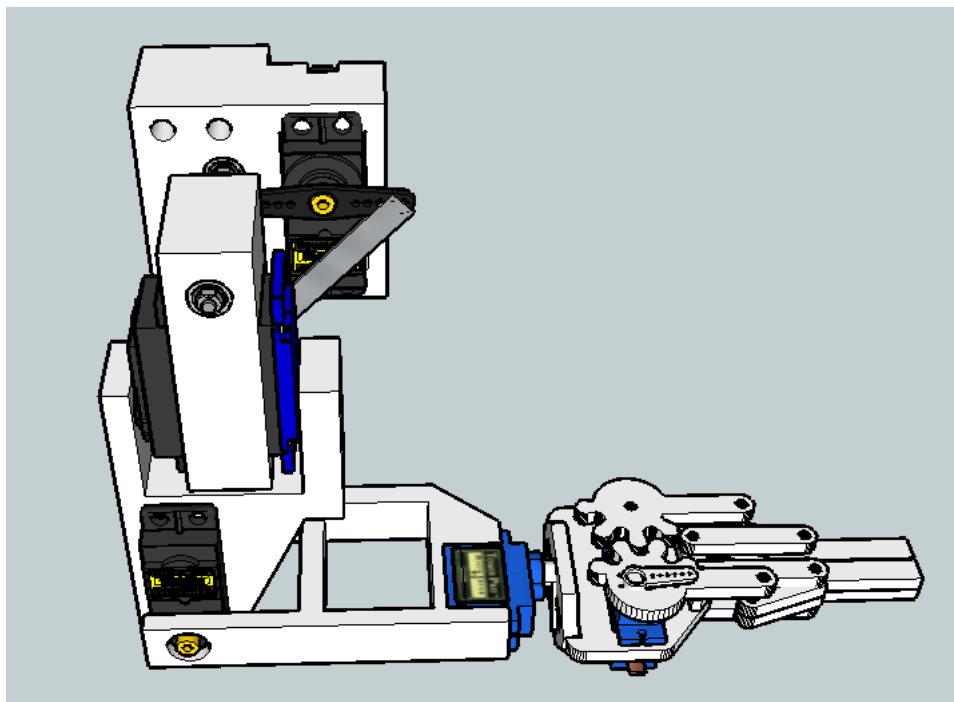

Figure 35: Detail of linkage between the shoulder servo and the upper arm

---

Figures 46 and 37 show how the Raspberry Pi and the webcam are secured to the robot's head with two stripes of 20x80mm velcro for the former and one stripe of 20x40mm velcro for the latter.

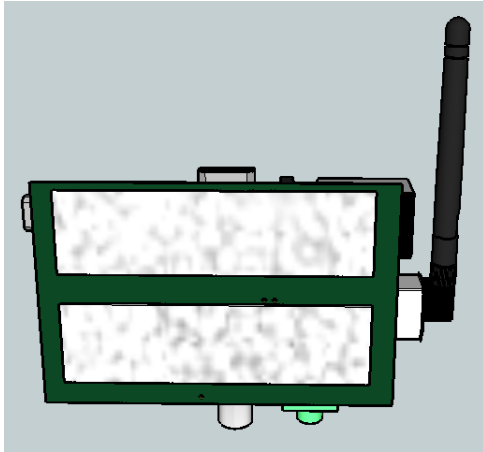

Figure 36: Detail of velcro stripes used to secure the Raspberry Pi

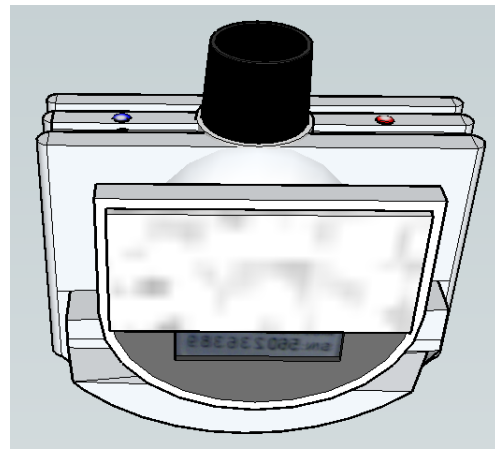

Figure 37: Detail of velcro stripe used to secure the camera

Similarly, both the Raspberry and the camera are attached to the head module through yet another set of two 20x80mm and one 20x40mm stripes of velcro, as seen in Figure 38.

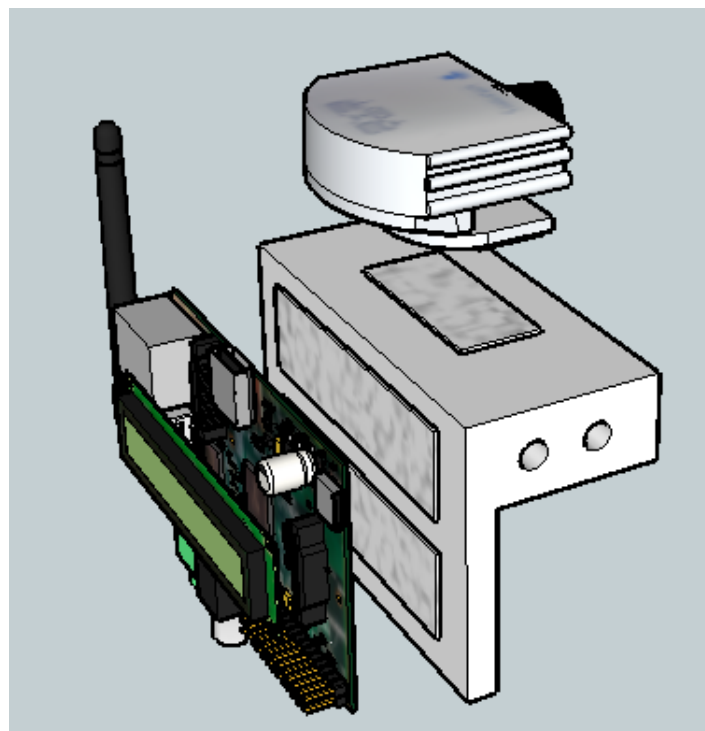

Figure 38: Coupling of the electronics to the robot's head

---

The procedure is repeated for the other arm, and both of these together with the head are fastened via two M5x250mm threaded rods and a set of six M5 nuts per rod to hold the different modules in position relative to each other (Figure 40).

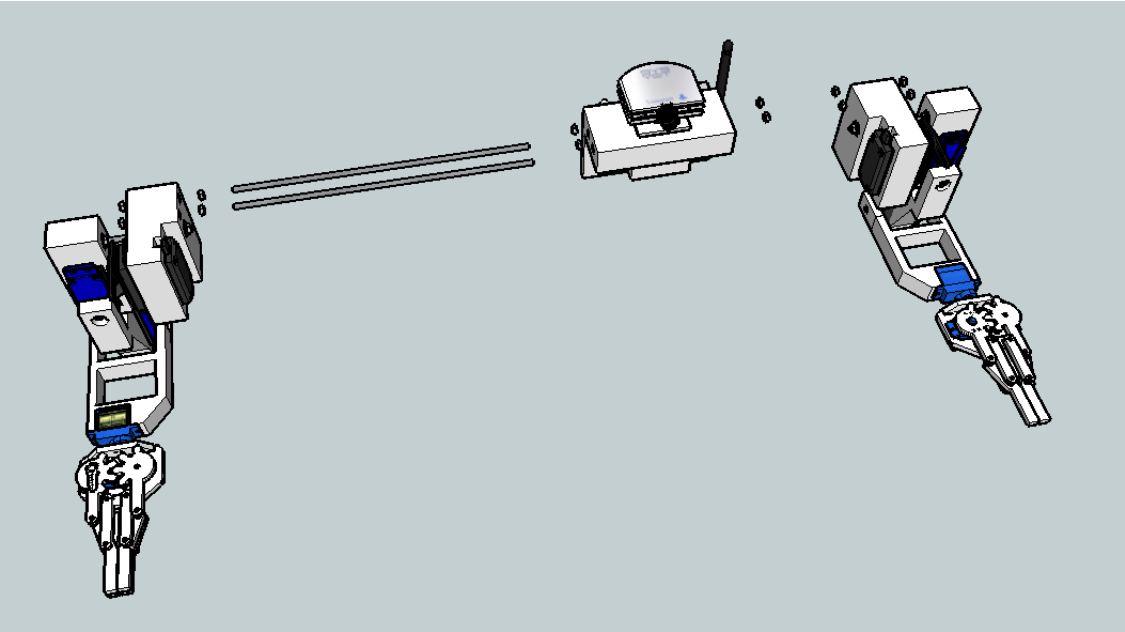

Figure 39: Assembly of the upper body

As shown in Figure 40, the upper body is kept in position by three pairs of rods, which prevent the body from tilting on either side nor falling forwards due to the arm's torque. The lateral rods are M5x220mm while the central ones measure 250mm while also being M5.

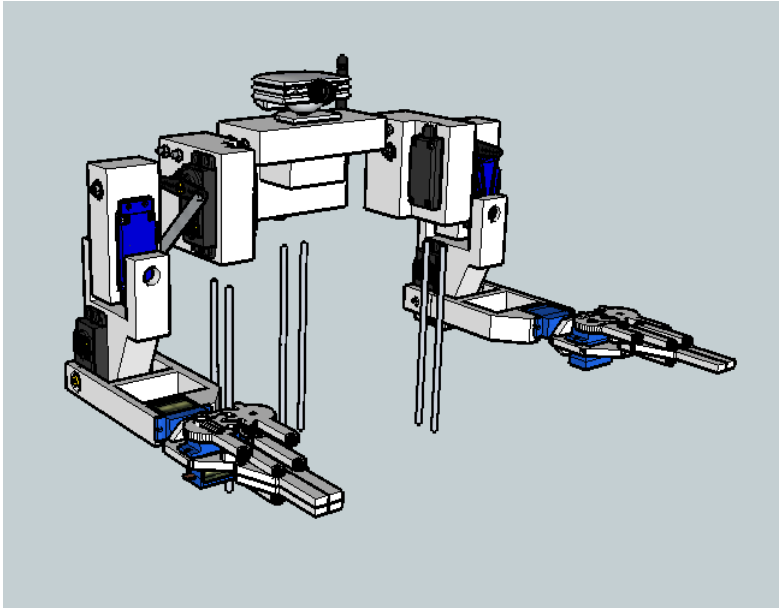

Figure 40: Detail of support rods insertion

---

The robot base consists of a 200x200x30mm wooden plank, chosen due to its resistance and as a faster and cheaper solution for a plane than a 3D printed part. The two motors are snapped into the wheels and fastened to the plank with zip ties while the caster wheel is screwed with four self-tapping screws (Figure 41).

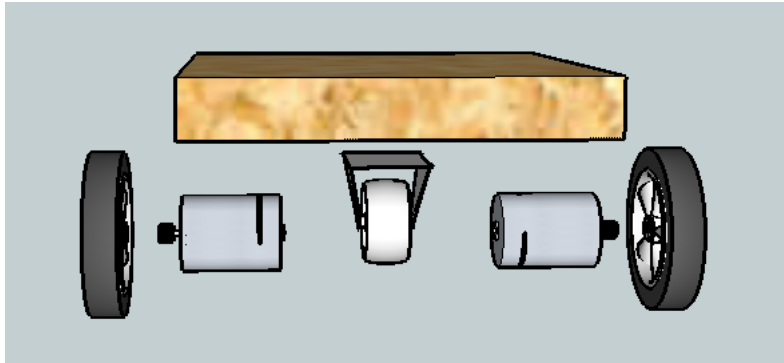

Figure 41: Detail of base assembly

The upper body and the base are then joined together as illustrated by Figure 42, by inserting M5 nuts at either side of each of the base throughout the rods.

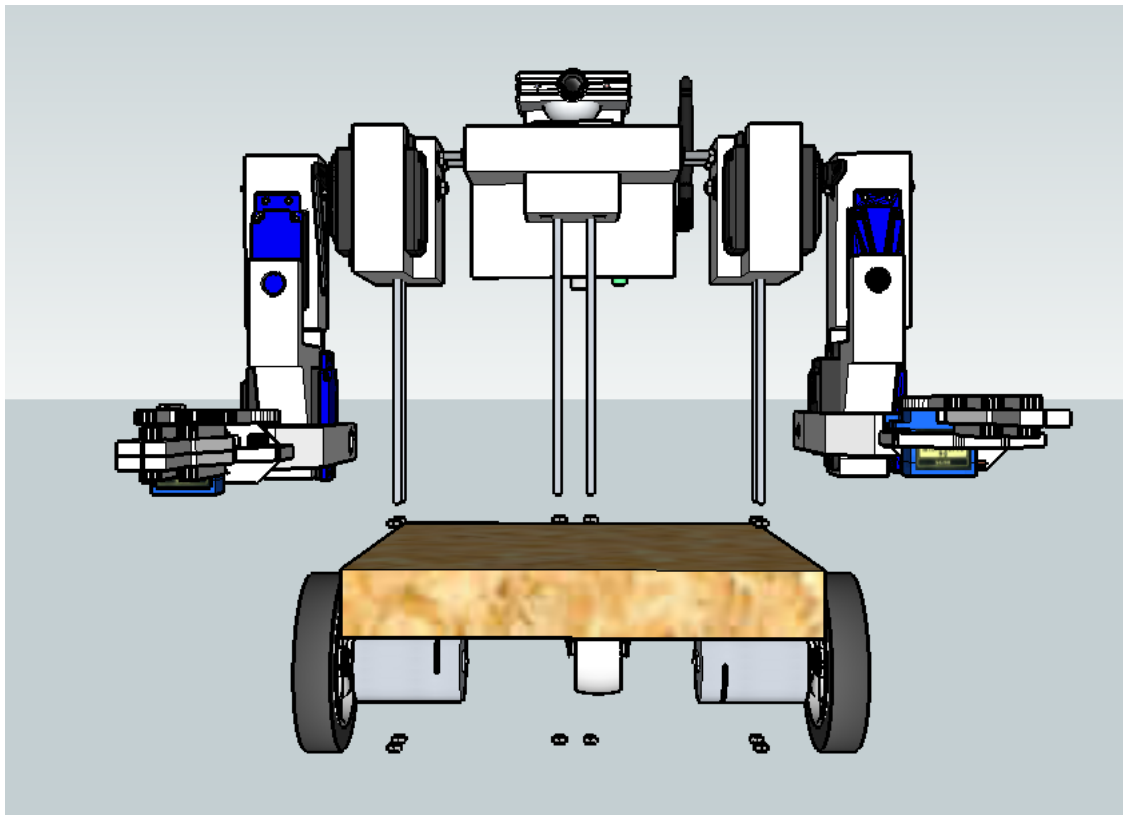

Figure 42: Connection of upper body to base



---

Figure 43 exhibits the disposition of two more 20x180mm velcro stripes intended to secure in place both the battery and the circuit board containing the Arduino, level converters and motor driver.

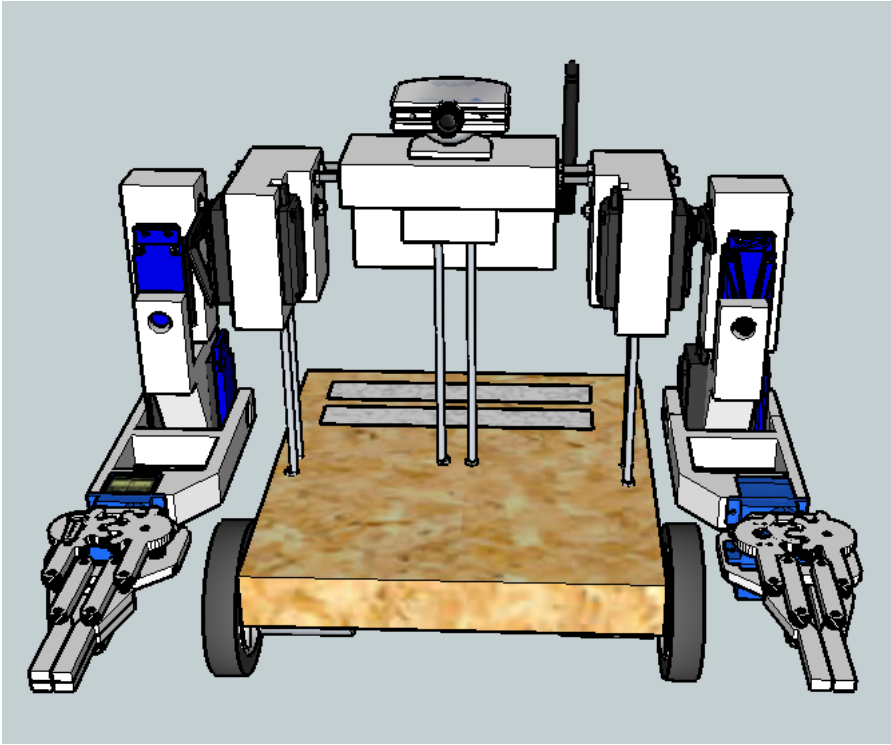

Figure 43: Detail of velcro stripes in the base

Figure 44 presents the velcro stripes at the bottom of the battery and circuit board. These are 20x100mm in dimension and are to be connected to the ones on the base of the bot.

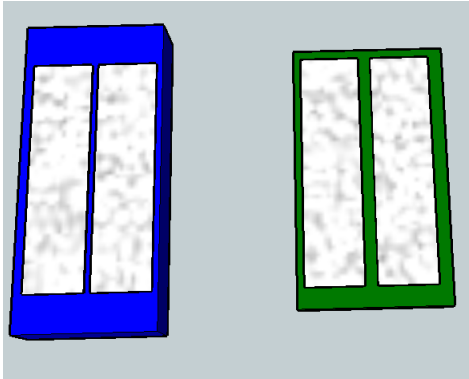

Figure 44: Detail of velcro stripes in the battery(L) and circuit board(R)

Finally, Figure 45 shows the robot fully assembled and in resting position.

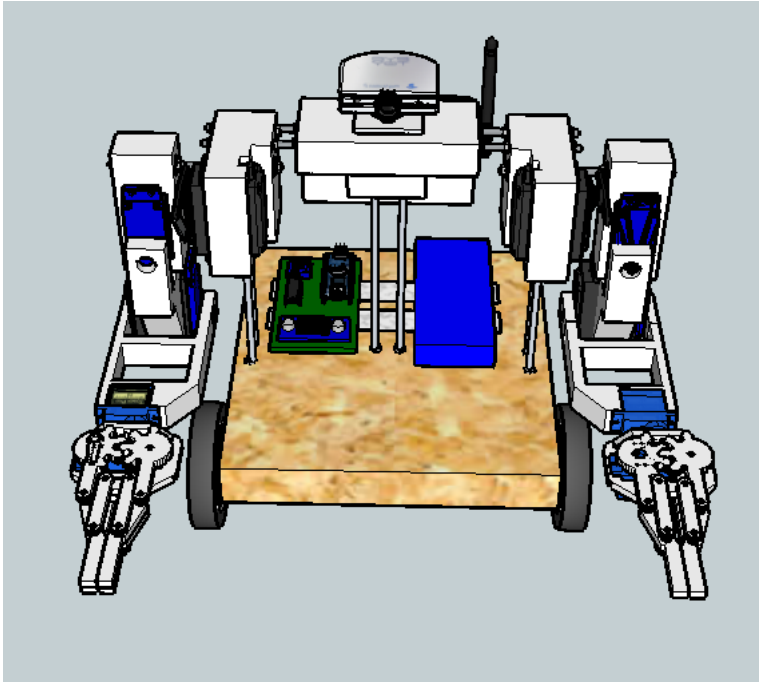

Figure 45: Assembled robot

Figure 46 lists all of the robot’s actuators for later identification, classifying them into servo-motors (S) or continuous motors (M) and left (L) or right (R) sides.

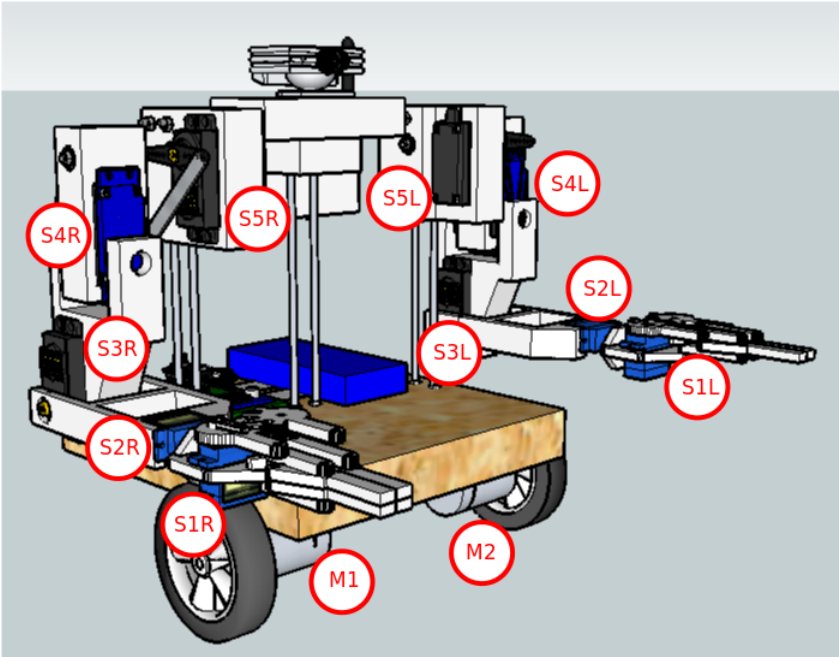

Figure 46: Detail of the robot’s actuators

---

## 5.2 Connections

This section will present how the different elements composing the robot are connected, first from the electrical point of view, then from a means of communication angle and finally from the different programs' interactions perspective.

### 5.2.1 Electrical connections

Figure 47 shows how the different electric and electronic components are interconnected. As it can be seen, different voltage levels co-exist within the robot, so regulators are placed to ensure the components function correctly.

The DC motors need the highest voltage to work, and so are connected to the battery, which provides them with the 12V they need. However they have to be controlled by the Arduino, hence the need for a driver that will turn on and off the 12V rails from 5V signals.

The rest of the components operate at 5V, which is why the step-down converter is used to convert the battery's 12V output into the desired level. The Raspberry Pi, Arduino and servomotors are connected to this rail.

Finally, the Raspberry communicates with the Arduino through the former's UART pins, which operate at a 3.3V level and can be damaged by the latter's 5V level pins. To avoid this a logic level shifter is introduced, which ensures data transmission without compromising the hardware's integrity.

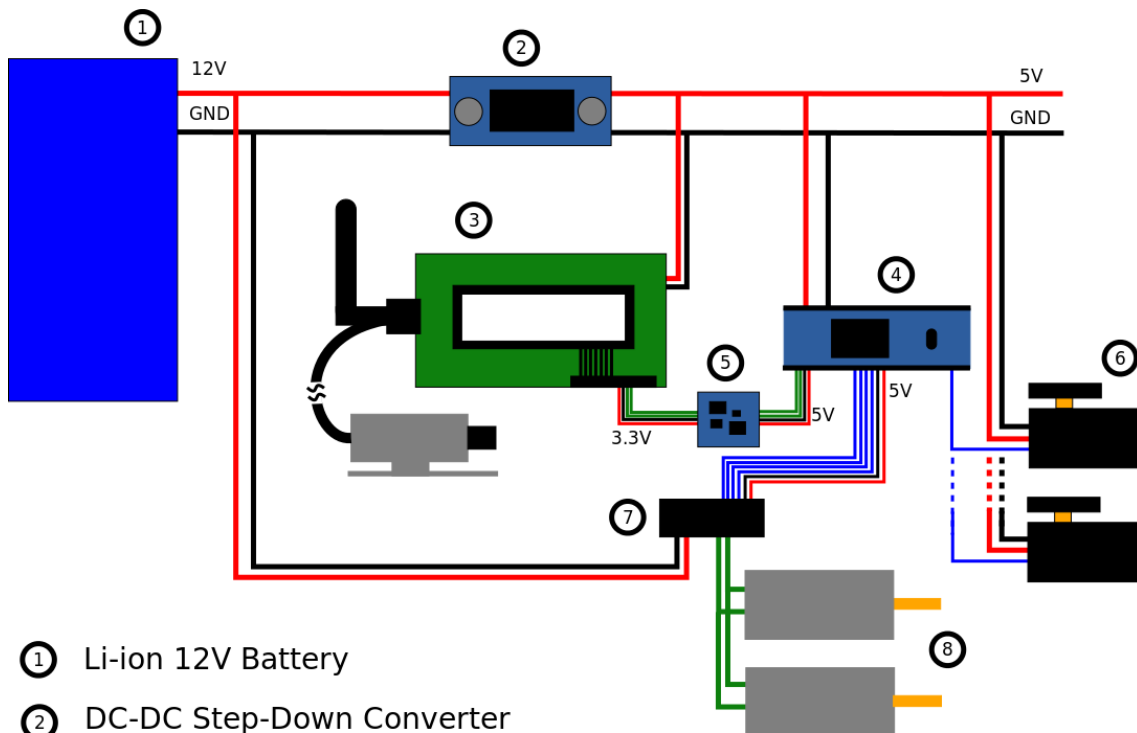

- ① Li-ion 12V Battery
- ② DC-DC Step-Down Converter
- ③ Raspberry Pi with accessories
- ④ Arduino Nano
- ⑤ Logic Level Shifter
- ⑥ Servomotors
- ⑦ L293D Motor Driver
- ⑧ DC Motors

Figure 47: Electrical connections diagram

The previous diagram shows how all components are interconnected, but to increase its clarity some connections have not been shown in detail. The following diagrams show how the remaining elements are wired pin by pin.

- Figure 48 shows the connections between the LCD and Raspberry Pi and the Raspberry, Arduino and the logic voltage shifter pins.

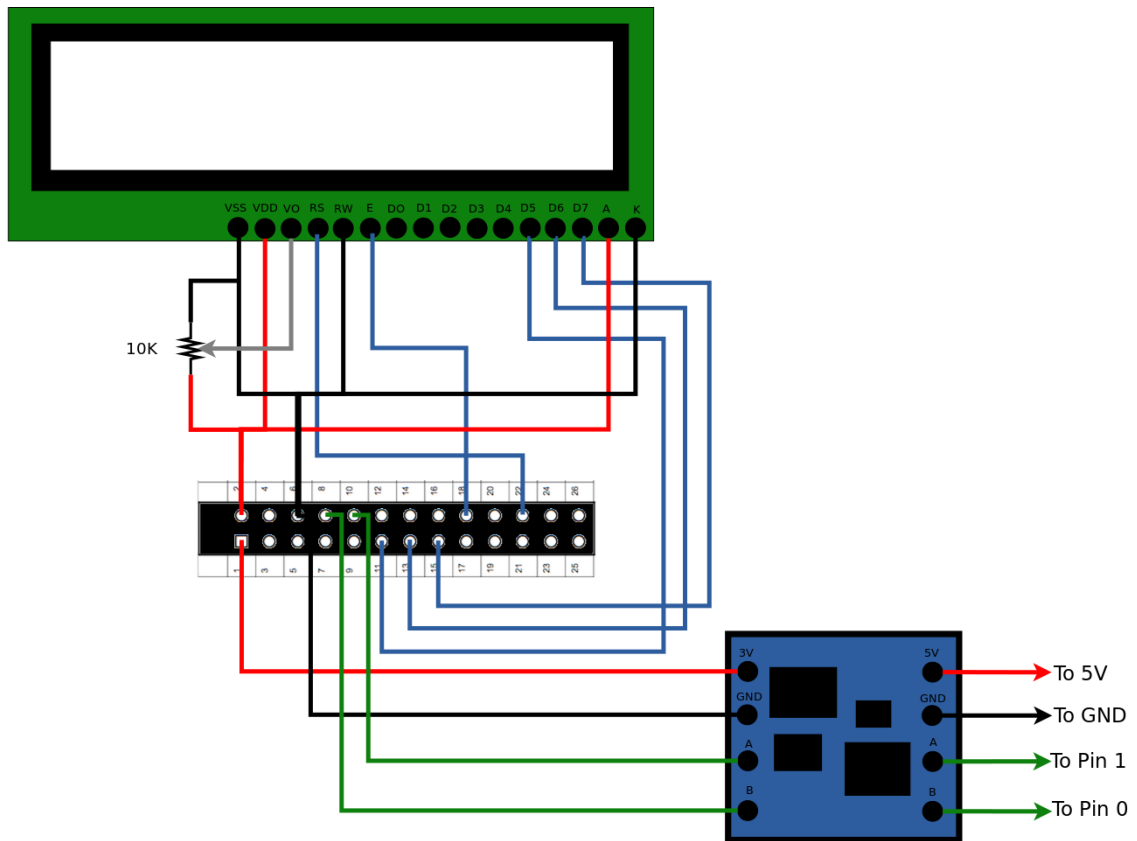

Figure 48: Detail of LCD and Serial connections

- Figure 49 shows the wiring between the motor driver, the motors and the Arduino.

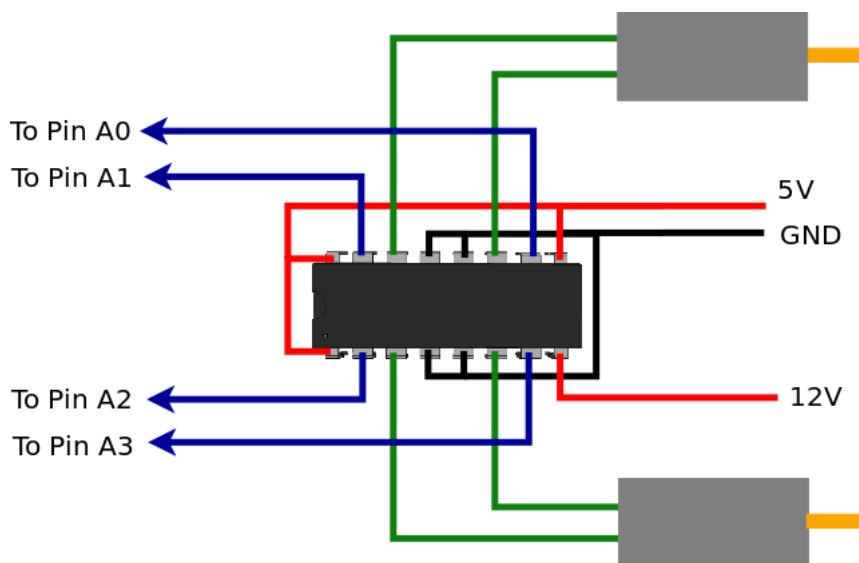

Figure 49: Detail of motor driver wiring

- 
- Figure 50 shows which element is connected to each of the Arduino pins.  
Note: The “TX” and “RX” elements refer to the Raspberry’s serial transmitter and receiver pins respectively.

Element	Arduino Pin
TX	D0
RX	D1
S1R	D2
S2R	D3
S3R	D4
S4R	D5
S5R	D6
S1L	D7
S2L	D8
S3L	D9
S4L	D10
S5L	D11
M1A	A0
M1B	A1
M2A	A2
M2B	A3

Figure 50: Table with the arduino pins assigned to each element

### 5.2.2 Logic connections

Figure 51 shows how the different components communicate between themselves. As it can be seen, the user controls the robot from the Android application. This implements a bidirectional communication over wifi with the Raspberry Pi, which is used to both send the Raspberry data concerning the movement of the different motors and to receive the video stream from the robot’s onboard camera. The Raspberry then communicates over Serial port with the Arduino, which takes care of the data received to obey the user’s commands.

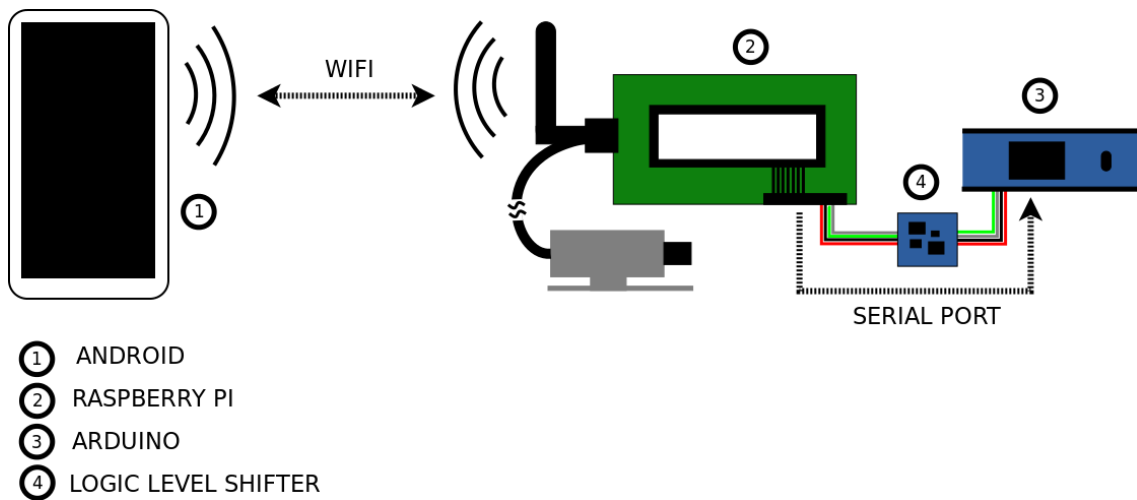

Figure 51: Logic connections diagram

### 5.2.3 Software connections

Figure 52 shows how the different programs interconnect the various components. It can thus be seen that the Raspberry Pi will first create a wifi network and then start to stream video through it. The android phone on the other hand will connect itself to the recently created network and will use it to emit the commands given by the user. The Raspberry will have already started the IP/UART Bridge, and will send the data received from the phone to the Arduino. Finally, the latter will execute its code to execute the orders received.

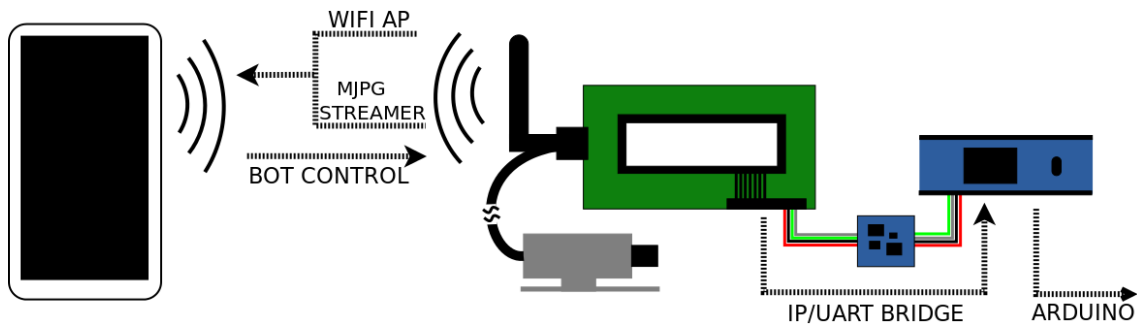

Figure 52: Software connections diagram

---

## 6 Arduino

### 6.1 Overview

Arduino refers both to the microcontroller board used to interface with sensors and actuators and to the software used to program it.

As a microcontroller, an Arduino is a relatively cheap development board useful for controlling many input and output pins, either digital or analog, in a single board solution that plugs directly into the computer over USB.

As a software environment, it provides a simple IDE with many code examples, a bootloader to program microcontroller chips directly with almost no external components and a growing user community that creates libraries for different sensors and communication protocols among others.

All Arduino programs follow the structure presented in Figure 53, namely one Setup function and one Loop function. The first is executed only once at the beginning of the program, while the latter is equivalent to a "while(1)" block, meaning that any code entered into it will be repeated until the microcontroller shuts down or is reset.

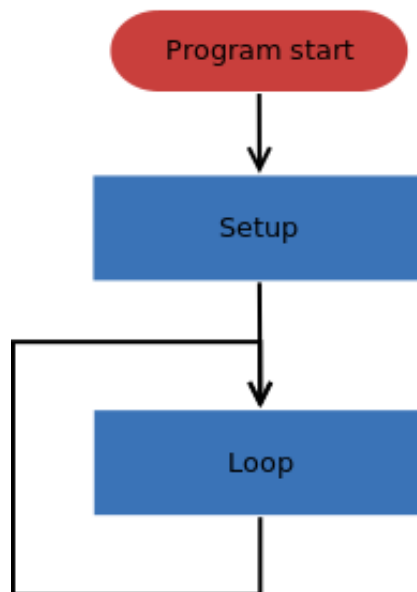

Figure 53: Arduino code skeleton



---

## 6.2 Code

In this section the code written for the robot's controller will be explained. A flowchart diagram of the program is illustrated by Figure 54.

- As it can be seen, the Arduino first defines all the robot's data, including the motor, servomotor and communication pins. This ensures the microcontroller knows where to send each datum once the user connects to the robot.
- The program then enters its Loop function. Here it will check if the serial port is available, eg the user has sent a stream of data. Once the port is available, the Read function is called, which stores every byte received into a string to be used later. Once the reading has ended the code checks if it has received a special end-of-line character that signals the end of the data stream. If all the data was retrieved the code moves on to the next function.
- The Parse function is called upon next. This function's purpose is to break and convert the previously stored string into the corresponding variables needed by each element, taking into account their sizes and types. Hence, it transforms one line of numbers into many parameters such as rotation angle, arm selection or movement direction which will be used by the next function.
- With the data correctly formatted, the program executes the Process function which is where the "thinking" is done. Here are defined all the rules the robot must follow, such as knowing which claw to close depending on the side chosen by the user but closing both if the symmetry box was checked. It takes the data provided by the previous function and processes them to end up with a structured list of variables ready to be assigned to each element.
- In the next step the Write function is called. This very simple function goes through the previous list assigning each variable to the corresponding element's assigned pins.
- Finally, the code clears the initial string to make space for new data, resets the flag informing of the correct retrieval from the serial port and proceeds to the next iteration within the Loop function, restarting the process.

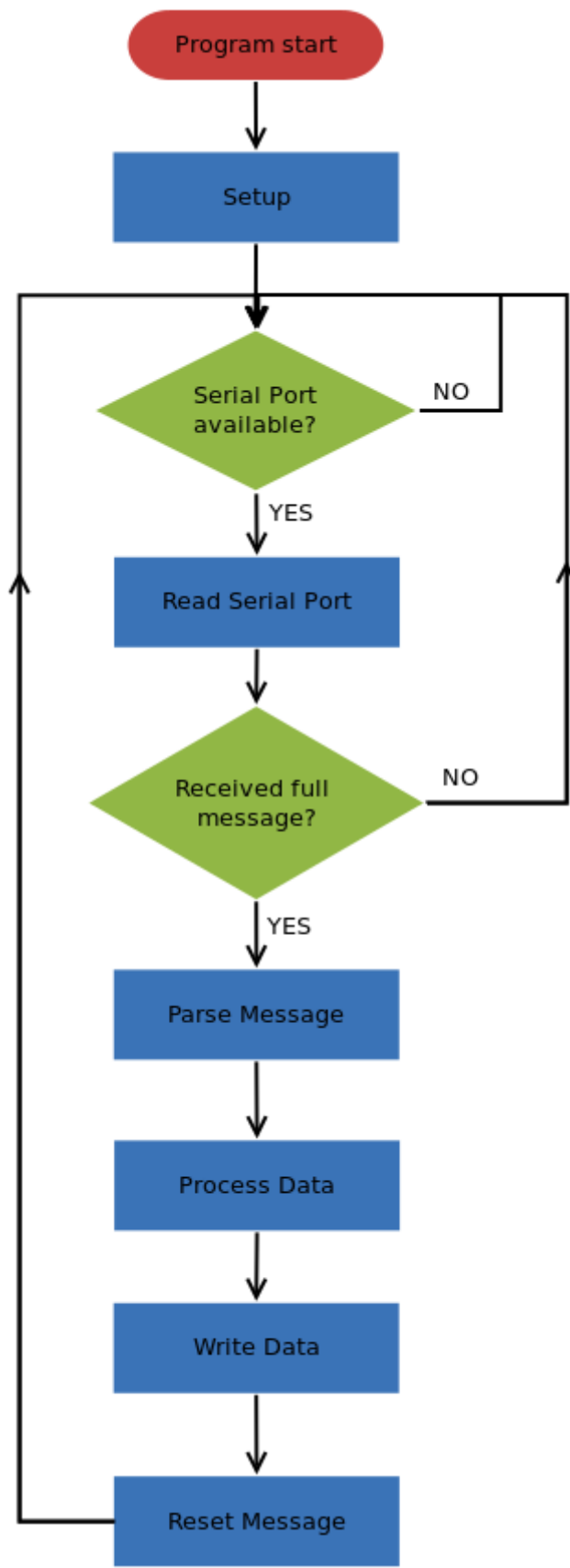

Figure 54: Arduino program flowchart

---

## 7 Raspberry Pi

The Raspberry Pi carries out three main duties to ensure everything works correctly. These include creating a wireless connection, streaming images from the camera to the phone and transmitting the data received from the phone to the microcontroller.

These are all placed into the */etc/rc.local* file so the system initializes them automatically each time the robot is turned on, with no need for human interaction.

### 7.1 Wireless communications

The chosen means of communication between human and humanoid was wifi. This is so because it is a widely established technology, with great compatibility and in a great number of cases is already installed in the homes of users. It also has a greater speed and range than other technologies, like bluetooth, which are an asset in the case of streaming images.

Three methods were considered: connection to an existing wifi network, creation of an Ad-Hoc connection and establishment of a wifi Access Point.

#### 7.1.1 Existing network

The most straightforward solution is to simply connect the robot to the user's existing wifi network. This enables the user to control it from anywhere in the world, expanding its uses. However, some configuration is required, namely selecting the desired network and introducing the password, which complicates the setup by having to add a keyboard and a display.

This method would thus be suitable for experienced users and developers, but not necessarily for the average seniors it is intended to help.

#### 7.1.2 Ad-Hoc connection

The next solution implemented was an Ad-Hoc connection between the Raspberry Pi and the Android phone.

This configuration aimed to solve the problem of usability, since the phone would automatically connect to the network, hence eradicating the problem of setting up the communication. This also had the advantage of creating an independent network, and thus being able to operate in remote areas.

In order to create implement this two files need to be set up. Firstly, the computer must be given the specific details of the new network to be created. Here, the contents of Listing 1 must be included into the file */etc/network/interfaces* .

---

Listing 1: Ad-Hoc Configuration [ /etc/network/interfaces ]

```
auto lo
iface lo inet loopback
iface eth0 inet dhcp

auto wlan0
iface wlan0 inet static
    address 192.168.1.1
    netmask 255.255.255.0
    wireless-channel 1
    wireless-ssid RPiAdHocNetwork
    wireless-mode ad-hoc
```

With this configuration the Raspberry will assign itself the IP address 192.168.1.1, but the client computer will be left without an IP assigned and so will be unable to connect to the former.

To provide an IP to the client the package *Isc-dhcp-server* must be installed by typing *sudo apt-get install isc-dhcp-server*

Listing 2 must then be included in file */etc/dhcp/dhcpd.conf*

Listing 2: DHCP Server Configuration [ /etc/dhcp/dhcpd.conf ]

```
ddns-update-style interim;
default-lease-time 600;
max-lease-time 7200;
authoritative;
log-facility local7;
subnet 192.168.1.0 netmask 255.255.255.0 {
    range 192.168.1.5 192.168.1.150;
}
```

After rebooting the Raspberry Pi, the Ad-Hoc network is created and ready to use. However, while it is compatible with a large range of devices like computers and iOS devices, non-rooted Android devices are not able to connect to the network, which invalidates this procedure as it is not suited for the general public.

### 7.1.3 Wifi Access Point

The last option for connecting the phone to the robot is to create a wifi Access Point (AP). This method involves a more complex setup than the previous, but while maintaining the same benefits, both allows Android devices to connect and supports speeds of up to 54 Mbps in 802.11g, while the former was limited to 11 Mbps in 802.11b.

The following section will explain how to establish this kind of connection. In order to do so both the Access Point host and the Dynamic Host Configuration Protocol (DHCP) server need to be configured, and will be so following the diagram in Figure 55.

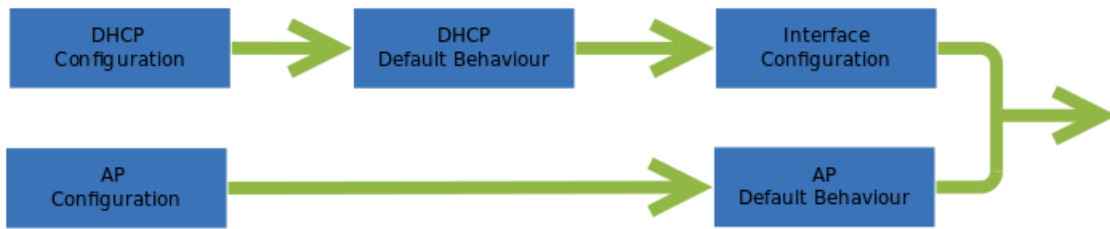

Figure 55: Wifi Access Point connection configuration

Firstly the *Hostapd* [32] and *Isc-dhcp-server* [33] packages have to be installed: `sudo apt-get install hostapd isc-dhcp-server`.

Once the needed packages have been installed the DHCP server must be configured in order to assign IP addresses to clients. The contents of `/etc/dhcp/dhcpd.conf` must be replaced with those in Listing 3.

Listing 3: DHCP Server Configuration [ `/etc/dhcp/dhcpd.conf` ]

```

# Sample configuration file for ISC dhcpd for Debian
# Attention: If /etc/ltsp/dhcpd.conf exists, that will be used as
# configuration file instead of this file.

# The ddns-updates-style parameter controls whether or not the server
# will attempt to do a DNS update when a lease is confirmed. We default
# to the behavior of the version 2 packages ('none', since DHCP v2
# didn't have support for DDNS.)
ddns-update-style none;

default-lease-time 600;
max-lease-time 7200;

# If this DHCP server is the official DHCP server for the local
# network, the authoritative directive should be uncommented.
authoritative;

# Use this to send dhcp log messages to a different log file
log-facility local7;

subnet 192.168.42.0 netmask 255.255.255.0 {
  range 192.168.42.10 192.168.42.50;
  option broadcast-address 192.168.42.255;
  option routers 192.168.42.1;
  default-lease-time 600;
  max-lease-time 7200;
  option domain-name "local";
  option domain-name-servers 8.8.8.8, 8.8.4.4;
}

```

The next step is to establish the interface on which DHCP Server should assign IP addresses.

---

This is done by copying the contents of Listing 4 to the file `/etc/default/isc-dhcp-server`.

Listing 4: DHCP Server Defaults [ `/etc/default/isc-dhcp-server` ]

```
# Defaults for dhcp initscript
# sourced by /etc/init.d/dhcp
# installed at /etc/default/isc-dhcp-server by the maintainer scripts

#
# This is a POSIX shell fragment
#

# On what interfaces should the DHCP server (dhcpd) serve requests?
# Separate multiple interfaces with spaces, e.g. "eth0 eth1".
INTERFACES="wlan0"
```

Afterwards, the "wlan0" interface must be set up. In this case any previous configuration will be deleted by replacing the contents of `/etc/network/interfaces` with those of Listing 5.

Listing 5: Interface Configuration [ `/etc/network/interfaces` ]

```
auto lo

iface lo inet loopback
iface eth0 inet dhcp

allow hotplug wlan0

iface wlan0 inet static
    address 192.168.42.1
    netmask 255.255.255.0
```

The DHCP configuration is now complete.

The Access Point setup has to be established next. A password-protected network will be created to ensure a secure connection. In this case its name will be "RaspiWifi" and its password "raspberrry". Again, the contents of `/etc/hostapd/hostapd.conf` should be replaced by those of Listing 6. This file is very sensitive, so no extra spaces are allowed.

---

Listing 6: AP Configuration [ /etc/hostapd/hostapd.conf ]

```
interface=wlan0
driver=rtl871xdrv
ssid=RaspiWifi
hw_mode=g
channel=6
macaddr_acl=0
auth_algs=1
ignore_broadcast_ssid=0
wpa=2
wpa_passphrase=raspberry
wpa_key_mgmt=WPA-PSK
wpa_pairwise=TKIP
rsn_pairwise=CCMP
```

Finally, the Raspberry has to be told where to find the configuration file previously created. The file `/etc/default/hostapd` must include the contents of Listing 7.

Listing 7: AP Defaults [ /etc/default/hostapd ]

```
# Defaults for hostapd initscript
#
# See /usr/share/doc/hostapd/README.Debian for information about
# alternative methods of managing hostapd.
#
# Uncomment and set DAEMON_CONF to the absolute path of a hostapd
# configuration file and hostapd will be started during system boot.
# An example configurationfile can be found at
#/usr/share/doc/hostapd/examples/hostapd.conf.gz
#
DAEMON_CONF="/etc/hostapd/hostapd.conf"
```

The only thing remaining is to start the AP service at boot, which is done with the command `sudo update-rc.d hostapd enable`.

This concludes the wireless communications setup, finally using the wifi Access Point method because of the advantages mentioned previously.

## 7.2 MJPG Streamer

One feature the robot implements is the ability to send a video feed to the user's telephone. This is useful in the case of a patient with limited mobility, as they can navigate it through the rooms of a house without having to follow it.

To achieve this the package `MJPG-streamer` is installed, which captures JPG shots from a camera connected to the computer and streams them as M-JPEG through HTTP to external viewers. It is downloaded from the official [repository](http://sourceforge.net/projects/mjpg-streamer/?source=navbar)<sup>3</sup> and built from source using the `GNU`

---

<sup>3</sup><http://sourceforge.net/projects/mjpg-streamer/?source=navbar>

---

*Make* utility.

Once built, the package includes three main files: `mjpg_streamer`, `input_uvc.so` and `output_http.so`, with each performing one part of the total procedure. More specifically,

- **mjpg\_streamer:** The core of the package, it copies JPG files from an input plugin to one or more output plugins.
- **input\_uvc.so:** The input plugin. It is charged of capturing JPG files from a connected webcam.
- **output\_http.so:** The output plugin. Its job is to stream the JPG files served by `mjpg_streamer` according to the M-JPG standard over a HTTP webserver.

The next step is to configure it by giving it the camera's location, the desired resolution and the number of frames per second. All of these parameters should be passed as arguments when calling the program from the command-line, but in order to simplify its initialization, the script in Listing 8 is created.

Listing 8: Streaming Initialization Script [ `startStreaming.sh` ]

```
#!/bin/sh
sleep 2
route="/home/pi/mjpg-streamer/mjpg-streamer-code-182/mjpg-streamer"
cd $route
sudo $route/mjpg_streamer -i "$route/input_uvc.so -d /dev/video0 -n
-f 7 -r QVGA" -o "$route/output_http.so -n -w $route/www"

exit 0
```

The robot now has the ability of streaming images from its webcam, which will be visible on the user's telephone and will give them the ability to control it remotely, even from out of their line of sight .

### 7.3 IP/UART Bridge

It uses the Adafruit-CharLCD library, which can be downloaded from their [repository](#) <sup>4</sup>, to enable writing to the LCD screen.

Figure 56 presents a flowchart of the socket to serial connection software.

The program creates a TCP socket server which continuously searches for clients until one of them connects. Once a connection is secured, the LCD changes from "Awaiting client" to "Client connected" and the program waits instead to receive data from the client. The data received is examined to check if it is a "quit" string, in which case the connection is closed and the program awaits another client. On the other hand, if the data is a valid string from the client, it is passed on through serial communication to the Arduino for it to use.

---

<sup>4</sup><https://github.com/adafruit/Adafruit-Raspberry-Pi-Python-Code>



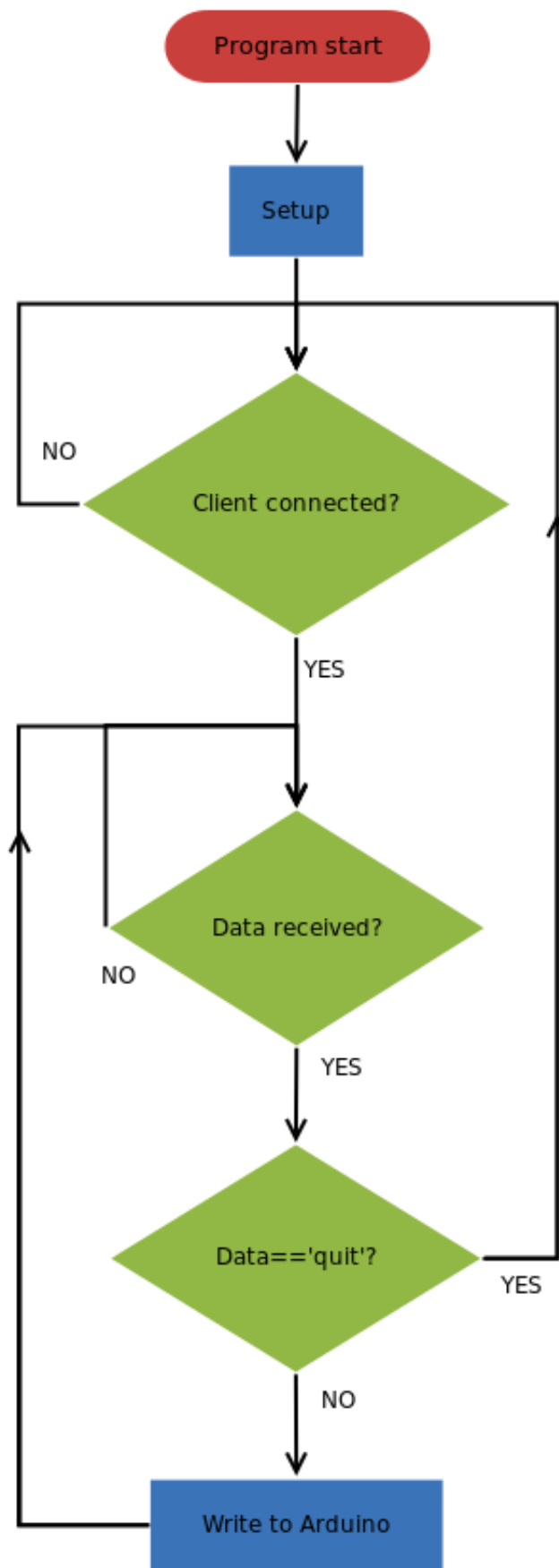

Figure 56: IP/UART program flowchart

---

## 7.4 Initializing script

One of the defining features of this project is that it must be usable by non-technological people, and so it must initialize every service it needs on its own.

To do so, the tasks previously defined are called automatically from a script when the system boots. The contents of */etc/rc.local* are executed right after the computer executes its own routines.[\[34\]](#)

Listing 9: Initialization Script [ */etc/rc.local* ]

```
#!/bin/bash

#Start ip Server
/etc/init.d/isc-dhcp-server start

#Start webcam streaming
#Runs on background so this script is able to launch the next item
#in list
/home/pi/mjpg-streamer/startStreaming.sh &
sleep 0.3

#Start Android to Arduino dumping
/home/pi/AndroidToArduino/startA2A.sh

exit 0
```

The file must be given executable permissions in order to be allowed to implement the commands specified. This is done by typing *sudo chmod +x /etc/rc.local* into a terminal window.

---

## 8 Android

### 8.1 Android overview

Android applications are typically programmed from Integrated Development Environments (IDE) such as Eclipse or Android Studio. The latter has been used in this because it is the official Android IDE supported by Google [35].

The typical app skeleton is shown in Figure 57 [36]. It consists of the following functions:

- **onCreate()**  
The first function Android calls when the application is launched. Here is where all the static elements are defined, such as setting the views.
- **onStart()**  
This function is called when the app is first visible to the user, after the previous function has ended.
- **onResume()**  
This method is called when the app is ready to interact with the user, ie. it is on top of the application stack and receives the user input.
- **onPause()**  
This is called when a previously started activity is going to be resumed. It is typically used to save data and stop resource consuming parts such as animations.
- **onStop()**  
Called when the activity is no longer visible to the user, either because another activity or the current one is being destroyed.
- **onRestart()**  
It is called when the activity is has been stopped, before it is restarted.
- **onDestroy()**  
If the activity is not restarted it is destroyed. It is the final function used in the activity and is called either explicitly with the *finish()* method or because the system closes it because it is low on resources.



---

## 8.2 Bot Control

The robot is controlled from the Android application Bot Control, seen in Figure 58. As it can be seen it is divided in two halves, with the upper half displaying the video received from the bot and the lower one encompassing the controls. The complete list of widgets include:

- A WebView connected to the url given by MJPG-Streamer which displays the video feed streamed from the webcam
- Four SeekBars, used to select the desired angle for each of the servomotors that position the arms
- A "Left/Right" Switch for selecting between the left and right arms
- A "Close" Button to close the claw of the current arm
- A "Reset" Button to reset the position of the arms, turning each servo at 90 degrees
- A "Symmetry" CheckBox to activate said option, under which both arms are controlled simultaneously and symmetrically
- Five direction Buttons to navigate the robot, which result in it moving forwards or backwards, turning left or right and stopping in place

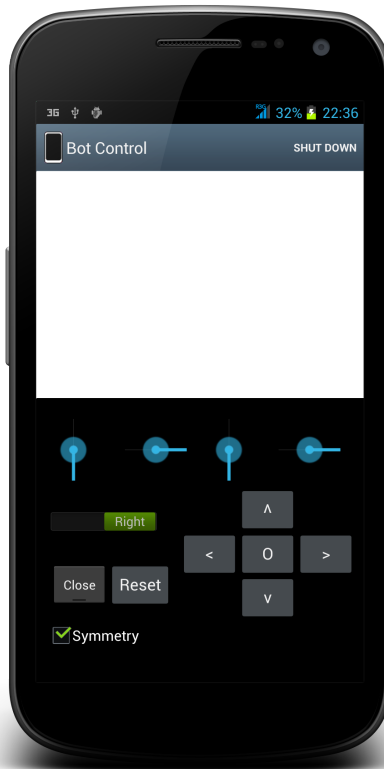

Figure 58: Bot Control application

---

The application follows the same general structure presented in the previous section. Here each function used will be analyzed if their default behaviour has been overridden. The following is a list of the modified functions specified in the program's code.

- **onCreate()**

This is the first function called upon start. The `clientThread` class is started here and the `WebView` connects to the robot's IP to reproduce the video stream.

The "Activity running" state is in this case composed by two separate functions, as illustrated by Figure 59.

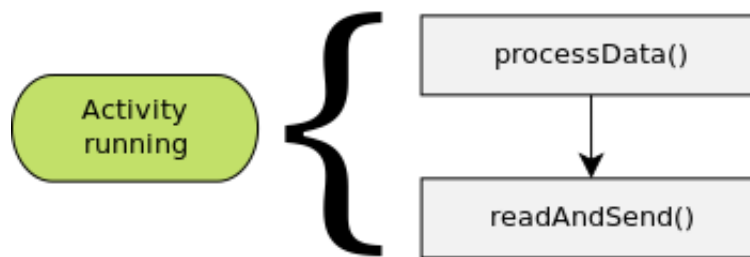

Figure 59: Detail of the "Activity running" state

- **processData()**

This function identifies and stores changes in movement parameters, such as those resulting in arm or body movement, and calls `readAndSend()` to send them to the robot.

- **readAndSend()**

This function is in charge of reading the values of non-movement parameters, such as symmetry or side selection, and sends these and the previous to the robot through the socket.

- **onStop()**

This is the last function to be called before the activity's destruction. It closes the socket after sending the "quit" keyword that tells the Raspberry Pi to start looking for clients again.

- **clientThread**

The runnable class `clientThread` is in charge of creating a socket client that will be used to send commands over wifi.

In conclusion, Bot Control sends information on the movements the robot needs to deliver while it displays what the latter sees, in order to be able to perform actions like grabbing a bottle from one room and navigating back to the user without having to follow it around the house.

---

## 9 Conclusion

### 9.1 Objectives completion

It can be said that the project *Design, construction and programming of a low cost, Open Source robot for assistive activities* has accomplished the objectives originally set:

- Different configurations have been studied in order to achieve a working prototype
- The final design, derived from the previous study has been modelled using the CAD program SketchUp
- The modelled parts have been created by means of a 3D printer
- The parts have been assembled and the electronics installed in order to create a functioning robot
- The Arduino board has been programmed to control both the arms as the base following the user's commands
- The Raspberry Pi has been programmed to:
  - set up a wifi network that enables bidirectional communication between the user and the PD-SD independently of pre-existing networks
  - stream the video feed captured by the on-board camera to the user's phone
  - receive the user's instructions and send them to the Arduino over serial communication while the socket connection maintained
  - initialize a script when booting to do all the previous automatically
- Program the Android application *Bot Control* to allow the user to take control of the Droid while being able to monitor what it sees

The robot is also low cost, as it can be seen in the “Budget” annex and Open Source, as all of the code can be downloaded from this [GitHub repository](#) <sup>5</sup>.

Finally, while it is a working prototype, it can be improved by implementing the suggestions found in the following section.

---

<sup>5</sup><https://github.com/alvaroferran/Proyecto>

---

## 9.2 Future work

The PD-SD is a very versatile robot, but it is far from complete and many new features can be added. A few of them could be:

**iOS application:** Although Android has the largest market share, iOS users are not negligible, and the most immediate improvement would be to develop a version of Bot Control for that system, in order to increase the number potential users.

**User routine programming:** Another interesting feature would be to include the ability for the non-technical user to program chores they want the robot to accomplish, such as bringing them a glass of water every morning or opening the blinds at a set hour.

This would give the users a higher quality service from their PD-SD, since they would be able to demand tasks as needed.

**Enhanced gripper:** The PD-SD currently features two parallel grippers, which enable it to grasp objects of different sizes due to the closing mechanism. However, complex figures may not be easy to hold to, and a vacuum gripper would be the ideal solution for this. By being pushed into the object while filled with air, the gripper adapts its shape to fit the object better, and when the air is removed the object remains firmly in place until it is released again. Figure 60 illustrates this procedure.

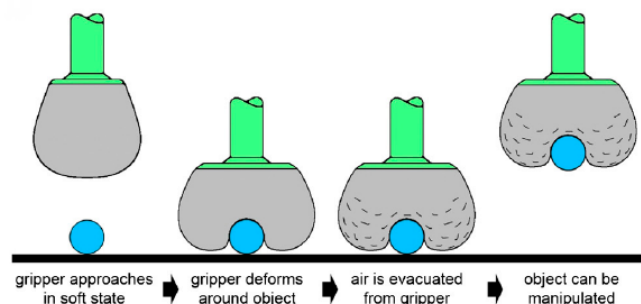

Figure 60: Vacuum gripper

**Full-size droid:** The final objective of this project is to eventually build a full-size robot capable of actually helping in the house by being able, for example, to reach into the higher cabinets of the kitchen or carry objects from one place to another.

In order to do this the robot must have a certain height and strength, so while the software would largely remain unchanged, the actuators and body parts would certainly need a revision.

**Computer vision:** Finally, adding computer vision capabilities to the robot would greatly enhance its capabilities. By integrating a library such as OpenCV, the robot could be able to recognize its charging dock by means of a symbol, or simply the phrase “Charging dock”, and could move towards it when the battery level descended.



---

Another feature would be to implement a pathfinding algorithm to take into account the walls, doors and floor of the house and make the robot navigate throughout it autonomously, for instance to fulfill one of the previously mentioned “programmed chores”.

---

## References

- [1] “The Monk Automaton of 1560” <http://thehairpin.com/2011/07/the-monk-automaton-of-1560-running-time-5-minutes-no-audio> Accessed: 2014-7-19
- [2] “Robotic construction crew needs no foreman” <http://www.seas.harvard.edu/news/2014/02/robotic-construction-crew-needs-no-foreman> Accessed: 2014-7-18
- [3] “Curiosity robot” <http://mars.jpl.nasa.gov/msl/> Accessed:2014-7-18
- [4] “Doctor explains da Vinci System, robot performing minimally invasive surgeries” <http://www.bakersfieldcalifornian.com/local/x167884620/First-Look-Doctor-explains-da-Vinci-System-robot-performing-minimally-invasive-surgeries> Accessed:2014-7-19
- [5] Salichs, M.A. “Maggie: A Robotic Platform for Human-Robot Social Interaction”, *Robotics, Automation and Mechatronics, 2006 IEEE Conference on*, 2009
- [6] Jardón, A. and Victores, J.G. and Martínez, S. and Giménez, A. and Balaguer, C., “Personal Autonomy Rehabilitation in Home Environments by a Portable Assistive Robot”, *Systems, Man, and Cybernetics, Part C: Applications and Reviews, IEEE Transactions on*,2011, [http://ieeexplore.ieee.org/xpl/freeabs\\_all.jsp?arnumber=5959995](http://ieeexplore.ieee.org/xpl/freeabs_all.jsp?arnumber=5959995)
- [7] “Spanish women behind only the Japanese in life-expectancy.” <http://www.fabproperty.com/spanish-women-behind-japanese-life-expectancy/>. Accessed: 2014-7-18.
- [8] “Trends in European life expectancy: a salutary view” <http://ije.oxfordjournals.org/content/early/2011/03/16/ije.dyr061.full> Accessed: 2014-7-18
- [9] “España lidera en Europa en uso de ‘smartphones’ con un 66% de tasa de penetración” <http://www.20minutos.es/noticia/1900266/0/espana-lidera/uso-smartphones/66-penetracion/> Accessed: 2014-7-18
- [10] “Report: Android reached record 85% smartphone market share in Q2 2014” <http://thenextweb.com/google/2014/07/31/android-reached-record-85-smartphone-market-share-q2-2014-report/> Accessed:2014-7-18
- [11] “Self-propelled Anthropomorphic Manipulator” <http://cyberneticzoo.com/teleoperators/1969-self-propelled-anthropomorphic-manipulator-sam-edwin-johnson-american/> Accessed: 2014-8-3
- [12] “Robonaut” <http://en.wikipedia.org/wiki/Robonaut> Accessed: 2014-8-3
- [13] “Robonaut: Home” <http://robonaut.jsc.nasa.gov> Accessed: 2014-8-3
- [14] “Asimo” [http://en.wikipedia.org/wiki/ASIMO#Development\\_history](http://en.wikipedia.org/wiki/ASIMO#Development_history) Accessed: 2014-8-3
- [15] “ASIMO, FAQs” <http://asimo.honda.com/downloads/pdf/asimo-technical-faq.pdf> Accessed: 2014-8-4
- [16] “Inside look: The technology behind ASIMO” <http://asimo.honda.com/Inside-ASIMO/> Accessed: 2014-8-4

- 
- [17] “RIBA II Healthcare Robot Gets Bigger Muscles, Cuter Ears”  
<http://spectrum.ieee.org/automaton/robotics/medical-robots/riba-ii-healthcare-robot-gets-bigger-muscles-cuter-ears> Accessed: 2014-8-6
- [18] “World’s first robot that can lift up a human in its arms”  
<http://rtc.nagoya.riken.jp/RIBA/index-e.html> Accessed: 2014-8-6
- [19] “Body weight: Global statistics” [http://en.wikipedia.org/wiki/Body\\_weight#Global\\_statistics](http://en.wikipedia.org/wiki/Body_weight#Global_statistics)  
Accessed: 2014-8-7
- [20] “About the RepRap Project” <http://reprap.org/wiki/About> Accessed: 2014-8-5
- [21] “Reprap Project” [http://en.wikipedia.org/wiki/RepRap\\_Project](http://en.wikipedia.org/wiki/RepRap_Project) Accessed: 2014-8-6
- [22] “Advantages and limitations of the Different Types of Batteries - Battery University”  
[http://batteryuniversity.com/learn/article/whats\\_the\\_best\\_battery](http://batteryuniversity.com/learn/article/whats_the_best_battery) Accessed: 2013-11-20
- [23] “7808 IC Regulator ” <http://www.electronics123.com/s.nl/it.A/id.937/.f> Accessed: 2014-1-7
- [24] “Buck Converters” <http://www.learnabout-electronics.org/PSU/psu31.php>  
Accessed:2014-1-7
- [25] “Buck Converters” [http://en.wikipedia.org/wiki/Buck\\_converter](http://en.wikipedia.org/wiki/Buck_converter) Accessed:2014-1-7
- [26] “How Servo Motors Work” <http://www.jameco.com/jameco/workshop/howitworks/how-servo-motors-work.html> Accessed: 2014-8-9
- [27] “WHAT IS ARDUINO?” <http://arduino.cc/> Accessed: 2014-8-9
- [28] “Arduino Nano” <http://arduino.cc/en/Main/arduinoBoardNano> Accessed: 2014-8-9
- [29] “WHAT IS A RASPBERRY PI?” <http://www.raspberrypi.org/help/faqs/#introWhatIs>  
Accessed: 2014-8-9
- [30] “Raspberry Pi” [http://en.wikipedia.org/wiki/Raspberry\\_Pi](http://en.wikipedia.org/wiki/Raspberry_Pi) Accessed: 2014-8-9
- [31] “The iPhone 6 Had Better Be Amazing And Cheap, Because Apple Is Losing The War To Android” <http://www.businessinsider.com/iphone-v-android-market-share-2014-5>  
Accessed:2014-9-10
- [32] “Hostapd : The Linux Way to create Virtual Wifi Access Point”  
<http://nims11.wordpress.com/2012/04/27/hostapd-the-linux-way-to-create-virtual-wifi-access-point/> Accessed: 2014-3-5
- [33] “ISC’s DHCP server software” <http://www.cyberciti.biz/faq/howto-ubuntu-debian-squeeze-dhcp-server-setup-tutorial/> Accessed:2014-3-5
- [34] “RC.LOCAL”<http://www.raspberrypi.org/documentation/linux/usage/rc-local.md> Accessed: 2014-3-25
- [35] “Android Studio” <https://developer.android.com/sdk/installing/studio.html> Accessed: 2014-3-8
- [36] “Public class Activity” <http://developer.android.com/reference/android/app/Activity.html>  
Accessed: 2014-3-8

---

# Appendices

## Appendix A Regulatory compliance

The present section presents the regulations the project complies with. These pertain both to the robot as a whole as to the different third-party components included.

### A.1 Domestic robots regulations

The project here presented is intended to be used as an assistive domestic robot. This class of robots follow the standard ISO 13482:2014, from 2014-02-19, and which can be found here. <sup>6</sup>

### A.2 MJPG-streamer

The video streaming program MJPG-streamer is released under the *GNU General Public License version 2.0 (GPLv2)*. The whole text can be found at <sup>7</sup>

### A.3 Hostapd

This software is licensed under the BSD agreement, which can be found in this website <sup>8</sup>

### A.4 Isc-dhcp-server

The Internet Systems Consortium's DHCP server software is released under the ISC license, similar to the BSD. The whole text can be found here <sup>9</sup>

### A.5 Gripper model

The gripper model used is released under the *Public Domain* license <sup>10</sup>, which grants the work to be *freely reproduced, distributed, transmitted, used, modified, built upon, or otherwise exploited by anyone for any purpose, commercial or non-commercial, and in any way, including by methods that have not yet been invented or conceived.*

### A.6 PD-SD

The Personal Domestic Service Droid is released under the Creative Commons Attribution 4.0 International License <sup>11</sup> (Figure 61). This license specifies that *You must give appropriate credit, provide a link to the license, and indicate if changes were made.*



Figure 61: Creative Commons Attribution logo

---

<sup>6</sup><https://www.iso.org/obp/ui/#iso:std:iso:13482:ed-1:v1:en>

<sup>7</sup><http://www.gnu.org/licenses/gpl-2.0.html>

<sup>8</sup><http://w1.fi/cgiit/hostap/plain/hostapd/README>

<sup>9</sup><http://www.isc.org/downloads/software-support-policy/isc-license/>

<sup>10</sup><http://creativecommons.org/licenses/publicdomain/>

<sup>11</sup><https://creativecommons.org/licenses/by/4.0/>

---

## Appendix B Project planning

This appendix breaks down the project into its different phases and their durations. The project started on 1st November 2013 and finished on the 7th October 2014, with blank periods during January, May and June, due to the examination sessions in the University.

Figure 62 summarizes the phases in a table detailing the duration of each one.

Phase	Begin date	End date	Number of days
Evaluation of different robot configurations	01/11/13	20/11/13	20
3D modelling	21/11/13	05/01/14	46
Assembly	28/01/14	15/02/14	19
Programming: Arduino	16/02/14	20/03/14	33
Programming: Raspberry Pi	03/03/14	25/04/14	54
Programming: Android	07/03/14	27/04/14	52
Report composition	15/07/14	20/09/14	68
Presentation preparation	21/09/14	30/09/14	10
<b>TOTAL DAYS</b>			<b>302</b>
<b>TOTAL HOURS ( 3 hours per day)</b>			<b>906</b>

Figure 62: Duration of each phase of the project

The Gantt diagram corresponding to this planning is shown in Figure 63

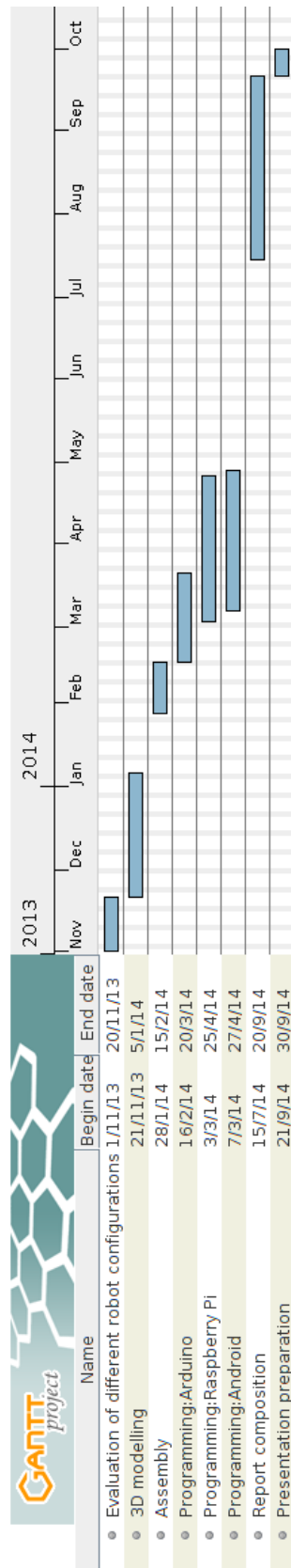

Figure 63: Gantt diagram specifying the duration of each of the project's objectives

## Appendix C Budget

Section	Description	Quantity	Price (unit)	Price (total)
<b>1</b>	<b>Software</b>			<b>0.00€</b>
1.1	SketchUp	1	0.00€	0.00€
1.2	Cura	1	0.00€	0.00€
1.3	Pronterface	1	0.00€	0.00€
1.4	Arduino 1.0.5	1	0.00€	0.00€
1.5	Android Studio	1	0.00€	0.00€
<b>2</b>	<b>Actuators</b>			<b>70.00€</b>
2.1	GA25Y370-362 DC motor	2	6.00€	12.00€
2.2	GOTECK GS-551MG servo	6	8.00€	48.00€
2.3	TowerPro SG90 servo	4	2.50€	10.00€
<b>3</b>	<b>Electronics</b>			<b>106.80€</b>
3.1	Raspberry Pi Model B	1	40.00€	40.00€
3.2	Arduino Nano v3	1	23.00€	23.00€
3.3	LCD screen 16x2	1	2.50€	2.50€
3.4	RT5730 WiFi USB	1	7.00€	7.00€
3.5	PlayStation 2 EyeToy	1	6.00€	6.00€
3.6	LM2596S step-down converter	1	2.30€	2.30€
3.7	JY-MCU logic level shifter	1	2.00€	2.00€
3.8	L293D motor driver	1	3.00€	3.00€
3.9	Li-ion 12V 6800mAh battery	1	21.00€	21.00€
<b>4</b>	<b>Other</b>			<b>5.00€</b>
4.1	3D Printing costs	1	5.00€	5.00€
<b>COMPONENTS TOTAL</b>				<b>181.80€</b>

The robot's components cost is of 181.80 €.

However, this only takes into account the cost of replicating the robot, not the actual cost of developing the project. In order to get the total cost for this project the engineer's man hours cost must be included, and these can be seen in the previous appendix.

The total number of hours being 906 at an hourly rate of 8€, the cost of man hours is  $906 \cdot 8 = 7248€$ .

Therefore, the project's total cost is  $181.80 + 7248 = 7429.80€$ .