

# CHALMERS



## An alternative Volt/VAR management scheme for Active Distribution Grids



Department of Energy and Environment  
Division of Electric Power Engineering  
CHALMERS UNIVERSITY OF TECHNOLOGY  
Gothenburg, Sweden 2014  
Master's Thesis 19/06/2014

Jesús García Benito  
Rocío Hoya Arija

## **Abstract**

Larger penetration of distributed generation and active loads is expected in the near future. These new loads have brought up new challenges to the electrical networks as well as new possible opportunities. The possibility of using these new elements to regulate and control the voltage is considered as the future scenario.

Therefore this thesis, develops a coordination between the most common elements in the networks (capacitor banks, STATCOMs, OLTCs/VRs and DGs), in order to study their interaction and how they together could manage the voltage level. In addition, EV charging station integration has been also evaluated. Considering this scenario, several simulations varying different parameters such as time delay or bandwidth are carried out. Also the concept line compensation is taken into consideration in the networks analysed.

Through all the simulations accomplished it is proved that a coordination is necessary between all the elements. Later on, a discussion about how each configuration affects the network complete this thesis. Besides, the simulated scenarios show that DGs and EVs can contribute to voltage regulation in an efficient way.

**Key words:** distributed generators, electrical vehicles, voltage stability, active distribution networks, distribution level.

## **Acknowledgements**

First and foremost, we would like to thank Chalmers University of Technology for giving us the chance to work and study this year within the Erasmus program, with all the facilities and resources.

Secondly, we would like to thank our supervisor at Chalmers, Dr. Héctor Zelaya, for his encouragement, support and discussion. We would also like to thank Dr. Ritwik Majumder for his technical contributions and continuous discussions. His answers and guidance have been a key factor in this thesis.

Johanna Barr's work was the basement of our thesis. Her incredible work motivated us to work harder during these months.

Also a big thank to all of our friends who supported us and helped us during these months.

And last and more important we would like to thank our families for supporting us. They encourage and motivate us in the hard moments.

The Authors, Gothenburg 19/06/2014

## Abbreviations

<b>AC</b>	Alternating current
<b>ADN</b>	Active distribution network
<b>ANM</b>	Active network management
<b>CIGRE</b>	International Council on Large Electric Systems
<b>DC</b>	Direct current
<b>DG</b>	Distributed generator
<b>DL</b>	Distribution level
<b>DMS</b>	Distribution management system
<b>DSO</b>	Distribution system operator
<b>DSTATCOM</b>	Distribution static synchronous compensator
<b>EV</b>	Electrical vehicle
<b>HV</b>	High voltage
<b>LV</b>	Low voltage
<b>MV</b>	Medium voltage
<b>OLTC</b>	On-load tap changer
<b>PCC</b>	Point of common coupling
<b>PI</b>	Proportional integral
<b>Pref</b>	Power reference control mode of DG model in this thesis
<b>pu</b>	Per unit
<b>PV</b>	Photovoltaics
<b>SCADA</b>	Supervisory control and data acquisition
<b>STATCOM</b>	Static synchronous compensator
<b>TSO</b>	Transmission system operator
<b>Vref</b>	Voltage reference control mode of DG model in this thesis
<b>VSC</b>	Voltage source converter
<b>VSM</b>	Voltage stability margin

## Symbols

<b>C</b>	Capacitance (F)
<b>L</b>	Inductance (H)
<b>P</b>	Active power (Watt)
<b>Q</b>	Reactive power (VAR)
<b>R</b>	Resistance (Ohm)
<b>S</b>	Apparent power (VA)
<b>V</b>	Voltage (Volt)
<b>X</b>	Reactance (Ohm)
$\omega$	Angular frequency (rad/s)

# List of Figures

2.1	General structure of an electrical network . . . . .	5
2.2	PV Curve . . . . .	6
2.3	Series and shunt voltage compensation . . . . .	7
2.4	Voltage regulator . . . . .	8
2.5	Capacitor bank . . . . .	8
2.6	Characteristic curve of STATCOM . . . . .	9
2.7	Parts of voltage regulator . . . . .	10
2.8	Signals for STATCOM/DSTATCOM control . . . . .	11
3.1	Hierarchy for the coordination of shunt and series regulation . . . . .	16
4.1	Simulation 1 - Load increases 33% at 0,6 seconds . . . . .	22
4.2	Simulation 1 - Power output of the different DGs . . . . .	23
4.3	Simulation 1 - Voltage along the feeder - Load increases 33% at 0,6 seconds	24
4.4	Simulation 2 - Load decreases 33% at 0,6 seconds . . . . .	25
4.5	Simulation 2 - Output power of the different DGs . . . . .	26
4.6	Simulation 2 - Voltage along the feeder - Load decreases 33% at 0,6 seconds	27
4.7	Hourly Projected EV Power Demand . . . . .	30
4.8	Simulation with EV integration at node 28 . . . . .	31
4.9	Voltage at node 33 with EV integration at node 28 . . . . .	31
5.1	Parallel coordination simulation - Without Line compensation considered	37
5.2	Parallel coordination simulation - Line compensation considered . . . . .	38
5.3	Voltage Node 14 – Base case . . . . .	40
5.4	Voltage node 14 - Different time delays . . . . .	41
5.5	Voltage along the feeder - Different time delays . . . . .	42
5.6	Voltage Node 14 – Base case . . . . .	43
5.7	Voltage node 14 - Different time delay . . . . .	44
5.8	Voltage along the feeder - Different time delays . . . . .	45
5.9	Voltage node 14 - Different bandwidth . . . . .	46

5.10	Voltage along the feeder - Different bandwidth . . . . .	47
5.11	Voltage Node 14 – Base case . . . . .	48
5.12	Voltage node 14 - Different time delays . . . . .	49
5.13	Voltage along the feeder - Different time delay . . . . .	50
A.1	Network for simulations 4.1 and 4.2 . . . . .	54
A.2	Network for simulation 4.3 and 4.4 . . . . .	55
A.3	Network for simulations in Chapter 5 . . . . .	56

# List of Tables

4.1	General impacts of high distributed generation penetration . . . . .	20
A.1	Network details for simulations 4.1 and 4.2 . . . . .	54
A.2	Network details for simulations 4.3 and 4.4 . . . . .	55
A.3	Network details for simulations in Chapter 5 . . . . .	55
B.1	Simulation 4.1 . . . . .	57
B.2	Simulation 4.2 . . . . .	57
B.3	Simulation 4.3 . . . . .	57
C.1	Simulation 5.1 . . . . .	58
C.2	Simulation 5.2 . . . . .	58
C.3	Simulation 5.3 . . . . .	58
C.4	Simulation 5.4 . . . . .	59
C.5	Simulation 5.5 . . . . .	59
C.6	Simulation 5.6 . . . . .	59
C.7	Simulation 5.7 . . . . .	59
C.8	Simulation 5.8 . . . . .	60
C.9	Simulation 5.9 . . . . .	60
C.10	Simulation 5.10 . . . . .	60
C.11	Simulation 5.11 . . . . .	60
C.12	Simulation 5.12 . . . . .	61
C.13	Simulation 5.13 . . . . .	61



# Contents

<b>1</b>	<b>Introduction</b>	<b>1</b>
1.1	Purpose of the thesis . . . . .	1
1.2	Method . . . . .	2
1.3	Limitations and assumptions . . . . .	2
1.4	Content of the thesis . . . . .	2
<b>2</b>	<b>System Operation in distribution level</b>	<b>4</b>
2.1	Voltage stability and regulation in DL . . . . .	5
2.1.1	Current Volt/VAR management regulation system . . . . .	6
2.2	Current devices operating in DL . . . . .	7
2.2.1	Series and shunt voltage compensation . . . . .	8
2.2.2	Control of devices . . . . .	9
2.3	Future DL landscape . . . . .	11
2.3.1	New relevant loads coming up in the grid . . . . .	12
2.3.2	Future DL . . . . .	12
<b>3</b>	<b>Integration of Distributed Generation in the Volt/VAR Management System for Active Distribution Networks</b>	<b>14</b>
3.1	Active Distribution Networks (ADNs) . . . . .	14
3.2	Hierarchical control approach . . . . .	15
3.3	IEEE-34 node network model . . . . .	16
3.3.1	Distribution network model . . . . .	16
3.3.2	Adaptive zoning . . . . .	17
3.3.3	Devices models . . . . .	17
<b>4</b>	<b>High penetration of DGs and EV integration in distribution networks</b>	<b>19</b>
4.1	High distributed generation penetration . . . . .	20
4.1.1	Planning Active Distribution Networks (ADNs) . . . . .	21
4.1.2	Simulations results . . . . .	21
4.1.3	Discussion and conclusion . . . . .	27

---

4.2	EV integration . . . . .	28
4.2.1	Impact of EV on electricity markets . . . . .	29
4.2.2	Profiles of EV charging station . . . . .	29
4.2.3	Simulations results . . . . .	30
4.2.4	Discussion and conclusion . . . . .	32
<b>5</b>	<b>Coordination of OLTCs/VRs in active distribution networks</b>	<b>33</b>
5.1	OLTC/VR features . . . . .	34
5.1.1	Key parameters of OLTCs/VRs . . . . .	34
5.2	Parallel coordination . . . . .	36
5.2.1	Model without considering line compensation . . . . .	36
5.2.2	Model considering line compensation . . . . .	37
5.2.3	Discussion and Conclusions . . . . .	39
5.3	Series coordination . . . . .	39
5.3.1	Model without considering line compensation . . . . .	39
5.3.2	Model considering line compensation . . . . .	48
5.3.3	Discussion and Conclusions . . . . .	51
<b>6</b>	<b>Conclusions, challenges and future work</b>	<b>52</b>
6.1	Conclusions . . . . .	52
6.2	Challenges and future work . . . . .	53
<b>A</b>	<b>Appendix A. Networks used for the simulations</b>	<b>54</b>
<b>B</b>	<b>Appendix B. Simulations details of Chapter 4</b>	<b>57</b>
<b>C</b>	<b>Appendix C. Simulations details of Chapter 5</b>	<b>58</b>
	<b>Bibliography</b>	<b>63</b>

# 1

## Introduction

The increasing penetration of active loads and distributed generators (DGs) in distribution systems has been investigated during the last decade. This brought up new challenges concerning the stability of electrical networks due to the absence of inertial sources and bidirectional reactive power flows present across the grid. These new loads can lead to voltage drops and rises at the nodes as well as disturbances in frequency stability.

DGs and active loads will be key loads for the network in the near future. Even though these loads might cause serious risks in the stability of the system, they will be useful if the reactive power can be kept under control and the voltage can be regulated at the point of common coupling (PCC).

An electrical network based on a high percentage of active loads is the future scenario predicted by experts. For that reason, it is important to improve both the technique and the processes controlling the system.

### 1.1 Purpose of the thesis

This thesis investigates the consequences of large volumes of active loads and DGs connected to the grid in electrical networks. The purpose of this thesis is threefold: to provide an accurate way to coordinate all DGs and active loads used in the system when they are dealing with other voltage controller devices; to analyze the possible instabilities caused by the interaction of aforementioned elements; and finally to provide a control scheme for future active distribution networks (ADNs). An improvement in the voltage profile for all network nodes is expected by controlling reactive power flow in the active loads and in the DGs.

## 1.2 Method

This thesis is based on a theoretical background study and it focuses on voltage regulation on the distribution level and on how the system operates. The main part of the work goes through several simulations, they represent cases of active loads in different grids. Furthermore, the coordination between different on load tap changer (OLTC) and voltage regulators (VRs) is tested in order to evaluate the best configuration scenario and to develop a new hierarchy for it.

The simulations are performed using the Matlab Simulink platform and they are based on the system IEEE 34 - node. Different parts of the aforementioned network are modified depending on each case.

## 1.3 Limitations and assumptions

In this thesis the following limitations are used:

- Among all devices and equipment available for voltage regulation in real distribution grids, only the most relevant are considered in this study: capacitor banks, DSTATCOMs, OLTCs/VRs and DGs.
- A radial distribution network is used for simulations. Structured mesh is not considered in this work.
- Only the voltage aspect of the distribution grid is considered - although there are other interesting aspects worth being studied such as frequency and economic and regulatory aspects.
- The variability of demand and generation profiles for the renewable-type DGs (e.g., wind and PV) is not taken into consideration.
- The model of the electric vehicle presented in this thesis is based on bidirectional injection of active and reactive power. It must be noted that its control has been developed in an elementary way.

## 1.4 Content of the thesis

Chapter 2 and 3 deal with the theoretical part of reactive power control and with the voltage profile in active distribution networks. Specifically, Chapter 2 focuses on the current operation of distribution level and on future components. This thesis continues Johanna Bar's work [1].

Therefore, Chapter 3 provides an overview and explanation of her project. Chapter 4 and 5 deal with the simulations in the system IEEE 34 - node. Finally, Chapter 6 presents the final discussions, conclusions and future challenges. Bibliography and appendixes come at the end of the work.

# 2

## System Operation in distribution level

The purpose of the distribution level (DL) in electrical networks is to deliver energy to the loads connected to it starting from the transmission substations or customers' small generating stations. [2]

The typical configuration for this level is a structured mesh with many supply points. However, meshed configurations are considered weak. For that reason they operate through a radial configurations by opening redundant branches. [3]

It is important to examine the R/X ratio which is naturally resistive due to the features of distribution networks. These networks usually have huge resistance values compared to reactance. This parameter also defines the time constant of a grid, which is really important regarding bandwidth of regulators.

In examining current electrical networks, three voltage steps are considered: high voltage step (HV > 38KV); medium voltage step (10 KV <MV< 36 KV); low voltage step (LV < 1 KV). The distribution part of a grid fits in the low voltage step, and sometimes in the medium voltage step. For residential customers and some industrial loads the most common voltage value is 400 V. [4]

The system operation of the distribution systems currently used is explained in this chapter. Subsequently, every device mentioned in this work is analyzed in detail. This chapter closes with a general forecast of future electrical networks. Figure 2.1 shows how current electrical networks look like.

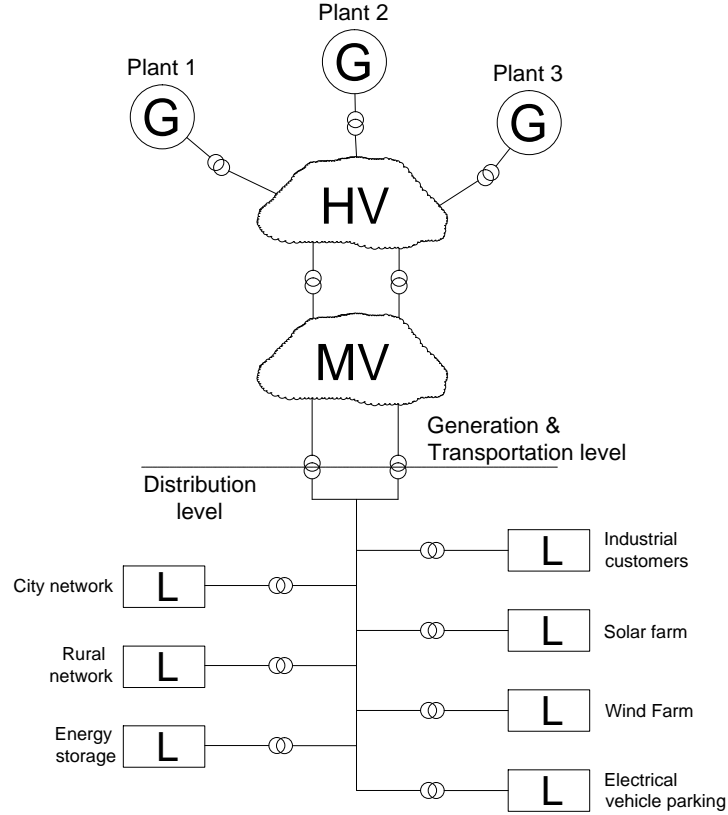
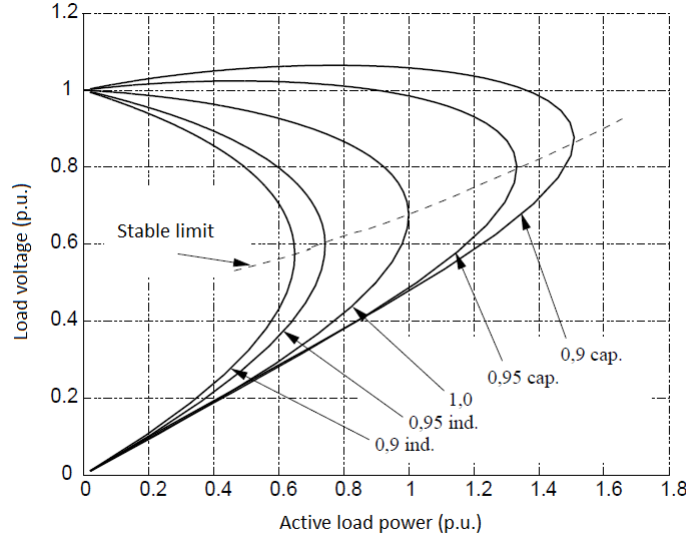

Figure 2.1: General structure of an electrical network

## 2.1 Voltage stability and regulation in DL

Voltage stability is one of the key parameters to be evaluated whether the electrical system is stable under normal operating conditions. In order to achieve stability, the system has to be kept at acceptable operating ranges even under disturbances. Disturbances occur when reactive power flows go through the lines and modify the voltage in the nodes. Sudden changes of load, switches in loads, or sudden supply losses are the main causes for instabilities in a grid.

The following PV Curve (Figure 2.2) illustrates the amount of active power that can be transferred while keeping the voltage within the limits. Each trajectory refers to different power factor levels, and represents the relationship between the load voltage and the active load power delivered. For every value of power transferred, there are two possible values of load voltage. However, when the system operates under the stable limit (knee of the curve), it becomes unstable. This situation can lead the network to voltage collapse. [5]



**Figure 2.2:** PV Curve

European standard EN 50160 regulation requires having the voltage range within  $\pm 10\%$  of rated voltage under normal operating conditions. Currently, Volt/VAR management is used to keep the system within these levels. [6]&[7]

### 2.1.1 Current Volt/VAR management regulation system

Volt/VAR management regulation system is the procedure which deals with voltage and reactive power control in DL. It aims to minimize the power losses and at the same time satisfy the voltage and loading requirements. [6]

The distribution system operation currently works through unidirectional power flows from HV to LV. Thus, changes in power demand are basically compensated on the transmission level.

Several devices such as capacitor banks, DSTATCOMs, voltage regulators or distributed generation units are used to regulate this process at the moment. When it comes to centralized control, the coordination of these elements is one of the main challenges. Therefore, it is necessary to monitor and control the system in its entirety in order to process the data in the network. “SCADA” is the software which handles the information of the system.

Thanks to this centralized procedure the system can achieve:

- Responding local controllers changing the system conditions.



- Different Volt/VAR Control objectives.
- Optimal Volt/VAR Control on a system level, not just on a local level.

Volt/VAR management has to face two principal challenges as the author of [8]&[9] pointed out:

- High penetration of DGs and active loads.
- Integration of power electronics interfaced DGs with the management system.

## 2.2 Current devices operating in DL

Voltage regulation can be performed in two different ways: shunt and series regulation. Shunt regulation includes all types of reactive compensation devices connected in shunt and series regulation includes voltage regulators and reactive compensators connected in series. The effects of these two types of regulation are: devices connected in series will increase the voltage downstream along the feeder, while shunt devices increase the voltage in its PCC. As it is shown in Figure 2.3 [1].

The location of these shunt regulation devices is essential for the proper operation of the network. Often, the shunt devices are located close to PCCs.

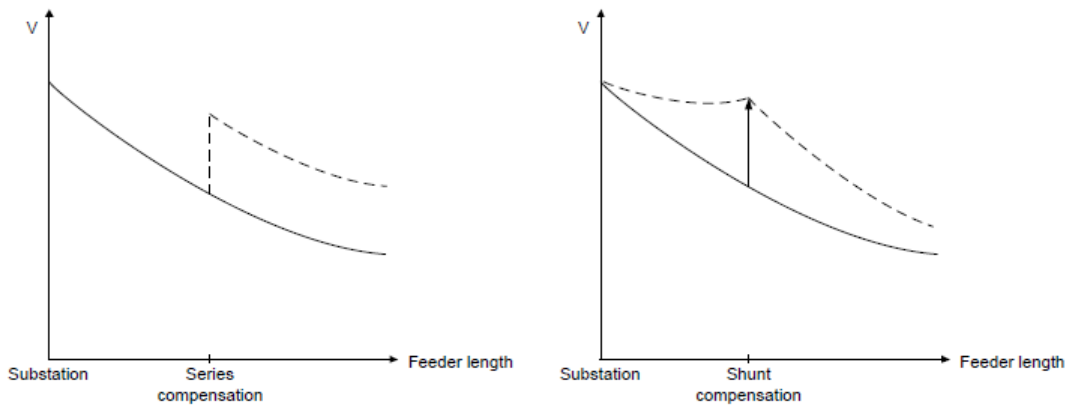

**Figure 2.3:** Series and shunt voltage compensation

### 2.2.1 Series and shunt voltage compensation

#### Voltage regulators

Voltage regulators are the most common devices currently used in grids, and also the earliest device implemented for voltage drop compensation [2]. It is mechanically activated, and it regulates the voltage by changing the number of windings. OLTCs are the most common used. [10]

As mentioned before these devices are connected to the feeder in series, and therefore, a change in the secondary side would increase the voltage downstream along the feeder. Figure 2.4 shows the appearance of a voltage regulator [11].



**Figure 2.4:** Voltage regulator

#### Capacitor banks

These devices are the cheapest, and simplest from a technical perspective. Capacitor banks are able to compensate loads with a poor power factor, however, its major problem is achieving optimum capacitance due to load variations over the melting cycle [2]. A common capacitor bank is depicted in Figure 2.5 [12].



**Figure 2.5:** Capacitor bank

### STATCOMs /DSTATCOMs

The primary purpose of static synchronous compensators (STATCOMs) is to supply a fast-acting, precise, and adjustable amounts of reactive power to the networks they are connected to. These devices regulate the amount and the direction of the reactive power flow. In fact, they adjust the magnitude and the phase of the reactive component of the current flowing through their AC side [13]. The next graph shows the behavior of STATCOMs [14].

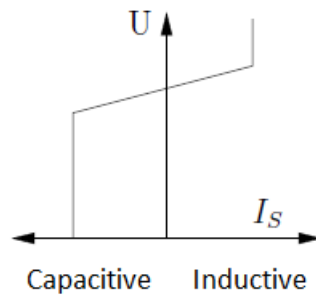

**Figure 2.6:** Characteristic curve of STATCOM

### Other components/tools

Besides those previously mentioned, other devices are used in the voltage control of the grids such as active filters, power factor controllers, or new energy storage loads. However, these components will not be considered in order to keep the network system and simulations within a reasonable scope.

### 2.2.2 Control of devices

When electrical devices are connected to the grid it is important to know their features in order to achieve the right connection. The most relevant parameters are: alternative current (AC), direct current (DC) and frequency of the system.

#### Voltage regulators

The parts of a voltage regulator are described and shown in Figure 2.7. [15]:

(A) Change-over selector: device designed to carry current used in conjunction with the selector switch to enable its contacts and the connection taps to be used more than once when moving from one extreme position to an other.

(B) Selector switch: switching device capable of making, carrying and breaking current, combining the duties of a tap selector and a diverter switch.

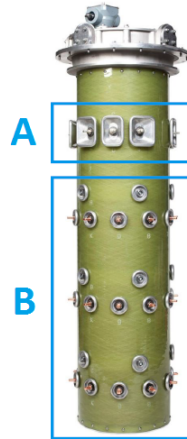

**Figure 2.7:** Parts of voltage regulator

The steps to operate a VR are [10]:

1. Select the tap connection
2. Divert the load current to the selected tap
3. Maintain the flow of power at all times
4. Prevent shorting the tap winding

### Capacitor banks

For reactive power control, capacitor bank configurations are accomplished through changing the connection according reactive load requirements. Mechanically switched capacitor banks are the most economical and valuable reactive power compensation resources nowadays. This is because they are simple devices, they do not effect on the short-circuit power and their low-cost for voltage control and network stabilization under heavy load conditions.[16]

Thyristors are used in order to achieve the connection to the network because it helps to avoid voltage fluctuations. [2]

The capacitor control measures the voltage, current and phase angle by converting the transformer's secondary voltage and current to data available.

### STATCOMs /DSTATCOMs

These devices also use power electronics converters to control the system and the reactive power delivered. They do not have a control loop for active power output, there is a DC voltage in the capacitor instead. This control maintain a constant capacitor voltage considering the error between the voltage reference and the measure voltage. [17]

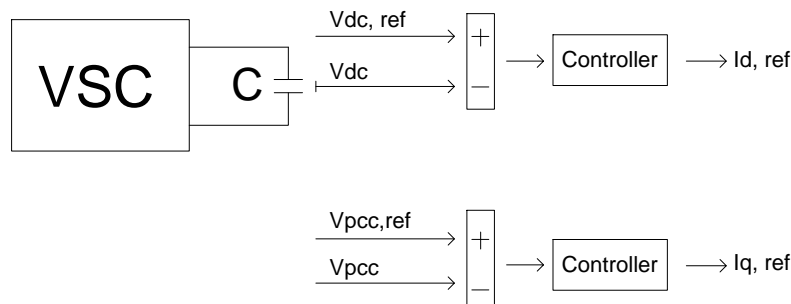

**Figure 2.8:** Signals for STATCOM/DSTATCOM control

As it is shown in Figure 2.8, STATCOMs/DSTATCOMs are connected to an energy storage device, controlled by a conventional standard d-q vector control technology.

Due to the advance of power electronic technology, voltage source converters based on IGBT technology have been increasingly used in modern STATCOM systems. They consist of a three-phase step-down transformer and a three-phase PWM rectifier/inverter (i.e., a three-phase bridge, a three-phase filter, line inductors, and a controller). [13]

## 2.3 Future DL landscape

Large amounts of papers have been written in the last decade about: future smart grids, how distributed generation impacts electrical networks, challenges of integrating distributed generation, ratios to define and evaluate the concept of 'high distributed generation penetration' or new Volt/VAR management systems for distributed generation.

In the article [18] a new variable to measure the ratio of active loads in grids is presented. It is expected to be a key parameter in the future. According to the definition of the penetration ratio, this formula can be obtained:

$$\gamma = (DG \text{ system capacity}) / (\text{Distribution network system capacity}) \quad (2.1)$$

As the article explains, a penetration ratio of 10% will already be considered as high penetration.

The authors of [18] set a strategy for goals to achieve by 2014-2016. The plan highlights three main strategies:

- Lead the transition to renewable energy
- Maintain reliability during industry transformation
- Lead regional collaboration

When considering both the future power markets and services related to reactive power, new policy regulation might be needed in order to face the new challenges.

### 2.3.1 New relevant loads coming up in the grid

Distributed generators (DGs): devices able to produce energy from co-generation (combining heat and power) and renewable energies (wind power, solar energy or geothermal energy). They are located in the DL. It is important to be aware of its small power capacity in order to evaluate its impact on networks.

Electrical vehicles (EVs): in the last decades, the environmental impact of petroleum, based on transportation infrastructure, has led to a renewed interest in electrical transportation infrastructure. Through this thesis a model of electrical stations for charging vehicles is analyzed in order to test its impact on the network and how it could contribute to managing the voltage.

### 2.3.2 Future DL

A network plenty of distributed generators and therefore less workload on a generation and transport level, is the future scenario. This new concept would reduce losses in the system, improving its efficiency.

The new loads previously described will play a key role in the grid in regard to voltage control and the reactive power flows (unnecessary reactive flows mean more losses). Although, a monitoring of all devices is necessary in order to avoid their interaction and therefore instability.

As it is explained in subchapter 2.1.2 a general scheme was developed to coordinate and control these new devices. The coordinated control used in this thesis is illustrated in Chapter 3.

# 3

## Integration of Distributed Generation in the Volt/VAR Management System for Active Distribution Networks

The thesis [1] investigates one of the significant problems of active distribution networks, i.e. distribution system voltage stability when the penetration of distributed generation increases. One way to secure this stability is to let DGs contribute to voltage regulation. However, it is necessary to coordinate the operation of DGs with conventional voltage regulation devices. In order to do this, the concept of hierarchies is introduced.

Active Distribution Networks (ADNs) are presented as the scenario of [1]. This work proposes a decentralized management configuration which addresses issues of distribution generation. At the same time, it avoids technical problems related to current Volt/VAR management. The need to divide the networks into zones must be taken into account. Through this division the volume of data to be handled decreases. The possibility of combining these zones in order to add flexibility to the grids is also illustrated .

This chapter contains a general view of what it is accomplished in the thesis [1]. Since this thesis continues Bar's work, it highlights its main concepts.

### 3.1 Active Distribution Networks (ADNs)

Wind, solar and co-generation technologies are presented as active loads or DGs as explained in 2.3. These new loads, because of their nature, are located within the DL.



The concept of ADN is introduced when a passive operation of distribution networks is transformed into active one.

To ensure the positive impact of these loads, a controlled system is needed in order to coordinate the multiple elements in the grid. Therefore this level must be controlled and monitored by a 'SCADA' system, which is capable of exchanging information in real time.

In addition, new market models and policy measures (regulatory frameworks) must be developed.

As the results of the paper [19] show, there is currently a large amount of work focused on ADN. The thesis [1], also contains an appendix presenting a landscape of current projects.

### 3.2 Hierarchical control approach

The hierarchies are based upon whether the devices are located at the same or different distance from the node where the disturbance occurs. There are different layers of control, so in the case where it is not enough with the first layer, the system continues with the next one.

The proposed solution considers different combinations of shunt devices (DGs , DSTAT-COMs , capacitor banks) and defines in what order they should contribute to the voltage regulation. Voltage regulators can be added to any of these combinations, thus there would be zones with shunt and series voltage regulation. This coordination control scheme has focused on the location and capacity of devices.

The principles used in the thesis [1] to create the control hierarchies are the following:

- Shunt regulation is used before series regulation, and finally, at the end of the process there is DG regulation. It must be noticed that series regulation devices should only be used when the increment of voltage downstream is all positive or negative.
- Concerning the distance from the devices to the critical node:
  - For shunt devices located at same distance, DGs regulate last.
  - For shunt devices located at different distances, the closest device regulates first.

The hierarchy shown in the graph below (Figure 3.1) is used in all the simulations in this thesis. The aim of these simulations is to evaluate the feasibility of this logical coordination in the future active distribution networks (with high penetration of DGs and EV integration).

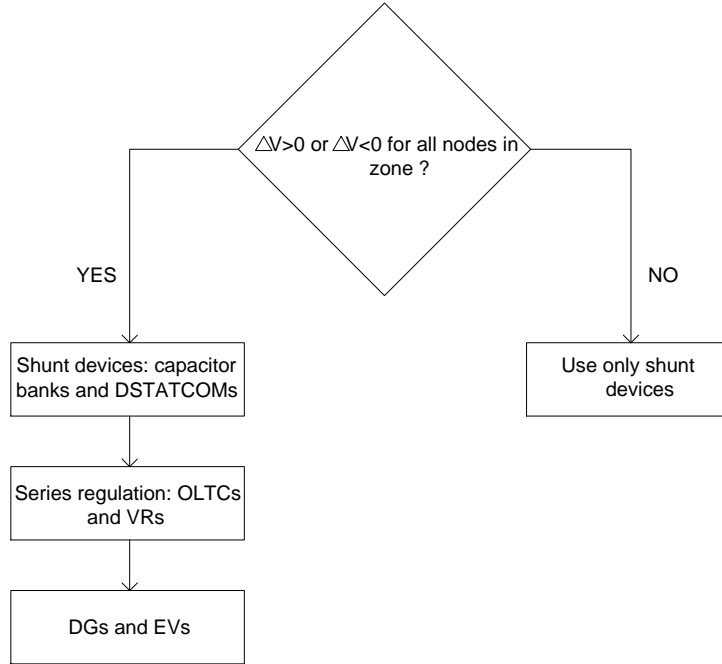

**Figure 3.1:** Hierarchy for the coordination of shunt and series regulation

### 3.3 IEEE-34 node network model

#### 3.3.1 Distribution network model

The simulations carried out in the next chapters are implemented in the Matlab Simulink platform. The modeled distribution network is based on the IEEE 34 - node test system with the required modification accomplished in [1] and some new changes.

IEEE 34 - node system represents a long and lightly loaded radial distribution network. The specific values for line impedance, loads and capacitor banks are listed in [20].

The most relevant changes from the original feeder are:

- New voltage level of 11kV instead of 24,9kV.

- All the parts of the feeder are three-phase and balanced. In the original system are single-phase zones with both three-phase and single-phase loads.
- For EV integration, the voltage in the branch of nodes 27 and 28 is changed into 400V.

The source is characterized by being a relatively weak voltage source ( $R/X$  ratio=0.2) with a short circuit capacity of 190 GVA and RMS phase-to-phase voltage of 69 kV.

Different configurations of the distribution network are considered to study the system behaviour after a disturbance. The disturbance is modeled as a 33% load increase/decrease at  $t=0.6$  seconds. The configurations used in each simulation are attached in Appendix A.

### 3.3.2 Adaptive zoning

The distribution network used in this thesis should be divided into different zones, as the thesis [1] explains.

The scheme in Appendix A (Figure A.3) shows the decentralized configuration for the system used in this work. In this way, Volt/ VAR management can be carried out locally within the zones or globally depending the requirements.

For this purpose, voltage has to be monitored in many nodes along the feeder. Nodes such as critical points where DGs, EVs and voltage regulation devices are located must be a priority, in order to save costs.

The IEEE - 34 nodes system is divided among: series zones which are separated by voltage regulators; and parallel zones which are referred to the different parallel branches. The cases tested refer to voltage drops in several zones along the feeder.

### 3.3.3 Devices models

In the following simulations the voltage regulation bandwidth is 0.95-1.05 pu as the standard European EN 50160 determines [7]. If voltage is outside these values, voltage regulation devices are activated. The different layers of the Figure 3.1 act to bring the voltage within the limits and reach the reference voltage ( set as 1 pu in this thesis). Nevertheless, the main goal of the simulations is to show the coordination of the devices.

The voltage regulation devices are set with a deadband of 150 milliseconds to avoid voltage fluctuation due to the activation at temporary disturbances. In the thesis [1] a Matlab scheme is developed to control each device in the system.

### **DGs**

In this thesis the model used for Bar's simulation [1] is considered, but with changes in the necessary parameters. Distributed generators are built with two possible modes of operation. The power reference mode is used under normal operation and the voltage reference mode is used when the DGs contribute to the voltage regulation.

### **DSTATCOMs**

These devices are able to either consume or transfer reactive power to the networks. The reactive power output is controlled using the reference voltage and measured voltage.

### **Capacitor Bank**

The capacitor bank used is the model included in the Simulink library.

### **OLTC/VRs**

The modeled voltage regulators can change their secondary side voltage up to  $\pm 5$ , 8 and 10 % depending on the bandwidth used.

In this thesis, VRs are assumed to be power electronic devices. This means that they work faster than the conventional ones. A mechanical delay of 20 milliseconds is used in the model based on the current devices on the market. The model used for OLTC is the same as the one used for VR, but it is placed directly after a voltage transformer.

### **EVs**

EVs charging stations are modeled as active and reactive power profiles injected into the grid. This represents the number of vehicles connected to the parking station which varies during the day. The control for EVs is developed in an elementary way.

# 4

## High penetration of DGs and EV integration in distribution networks

Over the past few years a lot of research has been conducted into how DGs impact electrical networks and the challenges of integrating and operating distributed generators.

In 2012, as the authors of [21] pointed out, the generation power of DGs on the total electricity production was more than 15% in some EU countries. The aim is that by 2020 renewable sources should make up 20-40% of the gross final consumption of energy in the EU. Most part of these renewable sources are expected to be categorized as distributed generation.

The power and energy sector across the world is nowadays concerned about the problems of conventional power generation (fossil fuels), this is one of the main reason of the spread of the increasing penetration of distributed generation. Besides, social awareness of the environmental impact of transportation has sparked an interest in cleaner and more efficient vehicles, such as the electrical ones. Therefore, it is necessary to have electrical EV stations, where people can charge their cars batteries.

Due to the high penetration of distributed generation, transmission levels are no longer the only responsible of the security matters in low voltage distribution networks. Distribution level should play a key role in security matters as well as power generation. Besides, the reliability of the penetration of DGs on the distribution systems has been carefully studied in order to maintain the level of reliability.

## 4.1 High distributed generation penetration

A large volume of new generation capacity, especially wind power, is expected to be connected to transmission and distribution networks in the next few years. These generators, located in the close proximity to customers, have become more and more important since they are able to considerably reduce the transmission and distribution losses.

Additionally, the penetration of the distributed generation has other pros, such as high energy efficiency, it is easily controlled and is small in size. Penetration of distributed generation implies an increase of extra generation to the passive networks, those are usually supplied by utility generators. [22]

However, the spread of DGs has been limited because of the presence of the long-established radial structured distribution networks. The main reasons are the fault current level increasing and the possible power flow inversion, impacting directly on the voltage regulation. In the following chart the general impacts of distributed generation on power system operation are shown:

**Table 4.1:** General impacts of high distributed generation penetration

Positive impacts	Negative impacts
Generation augmentation & better utilisation of assets	Changes in losses & voltage profile
Reduction of losses & transmission congestion	Voltage rise & fluctuations
Enhancement of reliability by ensuring continuity of supply	Frequency & voltage instability

There are a lot of recent studies about how distributed generation immersion affects the reliability of the system. For instance, the paper [22] developed several reliability indices in order to measure and evaluate the safety of a grid. For this purpose, they tested several grids and they noticed how DGs improve these parameters as far as the devices are located from the main supply point. Their results demonstrate that DGs clearly improve the reliability of a radial distribution network.

Thereby, regarding location of distributed generation it must be noted that DGs should be placed at the end of the feeders. This clearly improves the reliability of the systems.

#### 4.1.1 Planning Active Distribution Networks (ADNs)

The intermittency and the variety of renewable-type DGs (e.g. wind and PV) set challenges in planning distribution systems. Depending on the number of DGs operating, the required communication infrastructure should have a central control. This control should be technologically and economically viable. The coordination between voltage monitoring and communication systems by this central unit is a current topic of discussion as the authors of [23] have pointed out. Bi-directional communication among the customers and the central controller (Network Supervisor), allowing an adaptive area would be the scenario considered.

The authors of [24] illustrate that these networks with multi-DG configurations under Active Network Management (ANM) schemes could increase the potential of DGs capacity. The ANM schemes can enhance and maximize the utilization of network's assets under the current infrastructure and hence, decrease or avoid costly network upgrades. These schemes include the coordinated voltage control of OLTCs and voltage regulators, compensator reactive power control, DGs' power factor control and energy curtailment. [24] The ANM framework describes components and iterations necessary to support management within an active network.

The improvements of an active network compared to traditional networks are:

- Adaptive monitoring and predicting control.
- Custom code implemented by applications and devices that produce intelligent networks.
- Dramatically reduces protocol development time.
- Devices become network-aware and smart.

Nowadays, due to the increasing trend toward widespread usage of DGs, maximizing this phenomenon is a priority for DSO and TSO. ANM schemes have proved to be beneficial for DSO and TSO, compared to passive network management.

Therefore, DGs location and sizing are two critical factors. If DGs are properly located and sized, the total distributed generation capacity can be maximized while minimizing the use of ANM schemes. On the other hand, a wrong location may increase losses and costs of the operation system.

#### 4.1.2 Simulations results

The voltage variation problem is a critical issue for distribution networks. Typically, rural areas experience voltage rises and urban areas, with long feeder, voltage drops

[24]. For that reason, the disturbance considered in this part of the thesis consists on an increase and decrease of the industrial load. In this way, the response of DGs and the rest of devices in different areas is investigated.

For this section, the network described in Appendix A (Figure A.1) is used to test the behaviour of the system with high penetration of distributed generation. The simulation details are presented in Appendix B, Table B.1. and Table B.2. for simulation 1 and 2 respectively.

For simulation 1, a load increase is simulated. This causes a voltage drop below 0.95 pu in several nodes along the feeder. Following the hierarchy described in Chapter 3, the first activated devices for voltage regulation are DSTATCOM and shunt capacitor bank. Since voltages are still below 0.95 pu after this, due to their low power capacity in the model, the VR increases the tap setting until voltage is within the limits or until the maximum tap number has been reached.

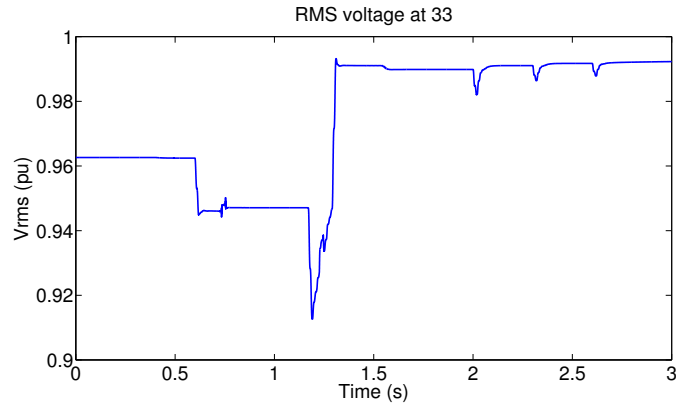

(a) Voltage at node 33

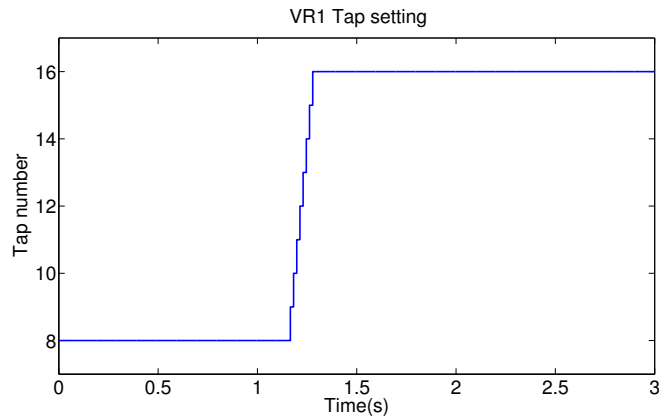

(b) Tap changes at Voltage regulator

**Figure 4.1:** Simulation 1 - Load increases 33% at 0,6 seconds



Figure 4.1.a shows the impact on voltage at the load side (Node 33). Figure 4.1.b shows the VR1 tap setting. It can be observed how the VR brings the voltage to the voltage reference value.

Although the voltage is already inside the range, DGs contribute to improve it until the rated voltage (1 pu). It is important to highlight the operation times of the different DGs: 2 seconds for the DGs in the node 18 and in the 33; 2.4 seconds for the DG in the node 32; 2.6 seconds for the DG in the node 31.

The next graph (Figure 4.2) show the power output of each DG located in the network.

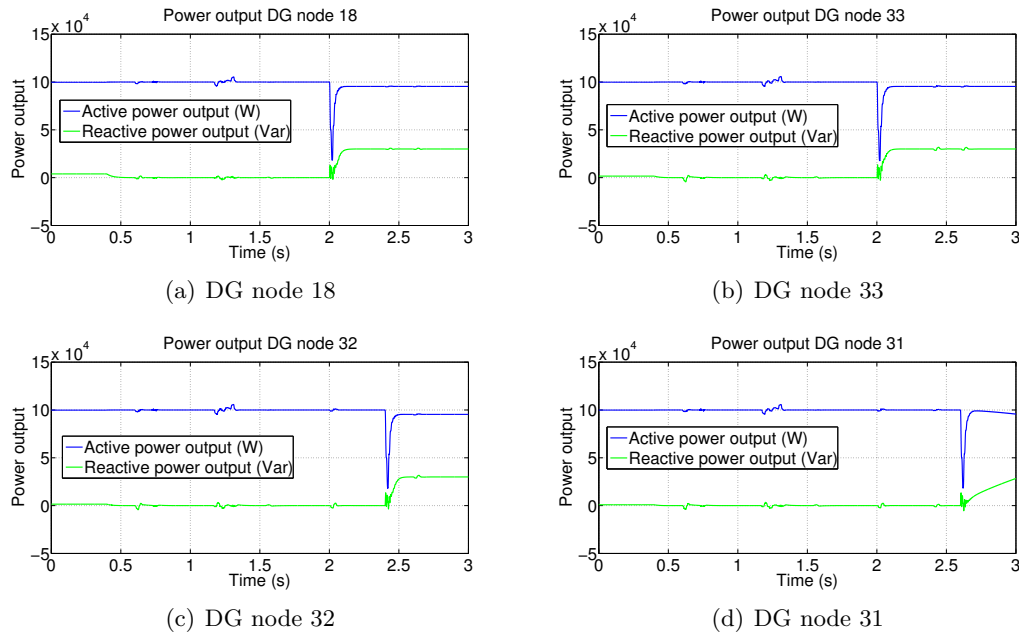
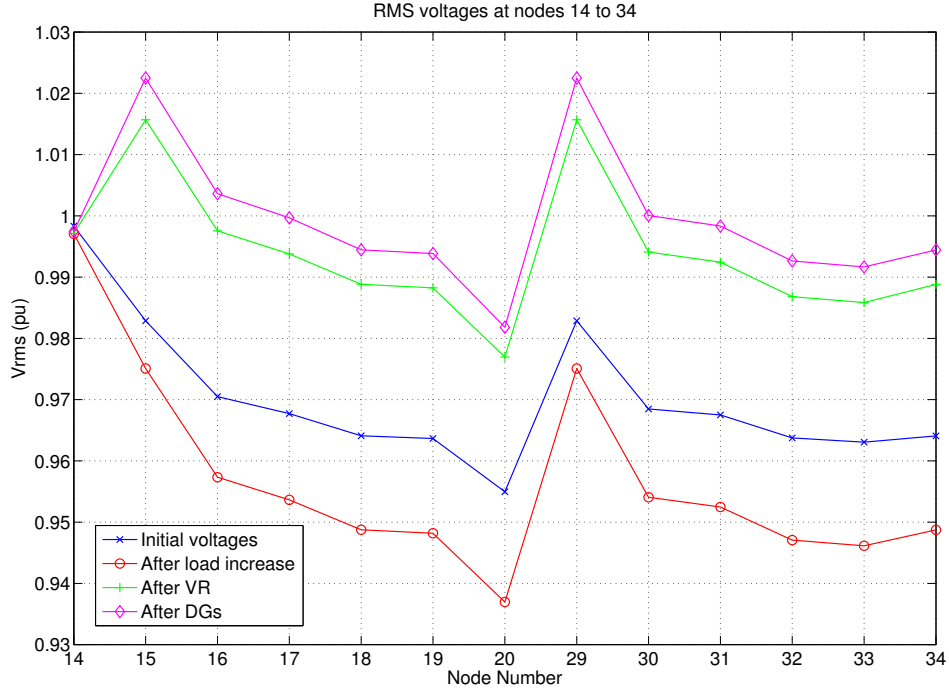

**Figure 4.2:** Simulation 1 - Power output of the different DGs

As it is presented in the four graphs above, each DG regulates in its time defined. They regulate using voltage reference mode. Therefore, they compensate the voltage in the network through the reactive power. The active power is adjusted to its correspond value.

The DGs used in the simulations have a power output of 100 KVA, as their graphs show.

For the third graph within this simulation (Figure 4.3), the voltage along the feeder is plotted in order to evaluate which amount of workload the DGs and VRs have accomplished respectively and how they impact the voltage.



**Figure 4.3:** Simulation 1 - Voltage along the feeder - Load increases 33% at 0,6 seconds

The improvement of voltage profile is caused by the existence of two different levels of control: devices and hierarchical control.

In this simulation DGs are modelled as constant power generators. In reality, the profiles of demand and generation production are variables of time. Nevertheless, a realistic scheme could be created using historical data.

DGs contribute to bring the voltage within the limits but the main workload is achieved by the voltage regulator.

For simulation 2, at  $t=0.6$  seconds both industrial loads decreased by 33%. This causes a voltage raise along the feeder. As in the first simulation: DSTATCOM and shunt capacitor bank regulate first, the VR brings the voltage within the limits later, and the DGs also contribute to voltage regulation at the end. The operation times of DGs are also the same as the simulation 1.

Figure 4.4.a shows the voltage profile for the node of disturbance (33) and Figure 4.4.b shows the voltage regulator behaviour with its tap changes.

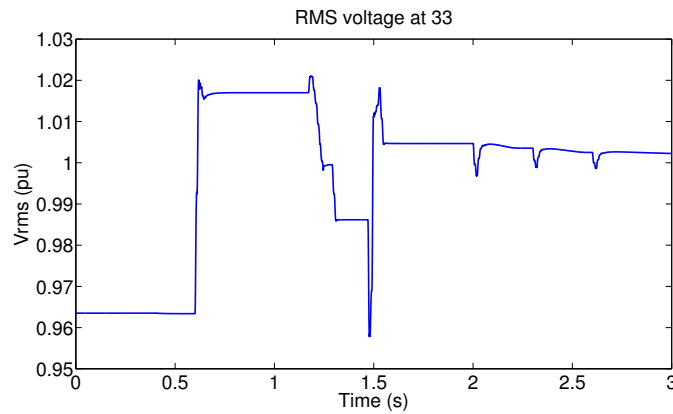

(a) Voltage at node 33

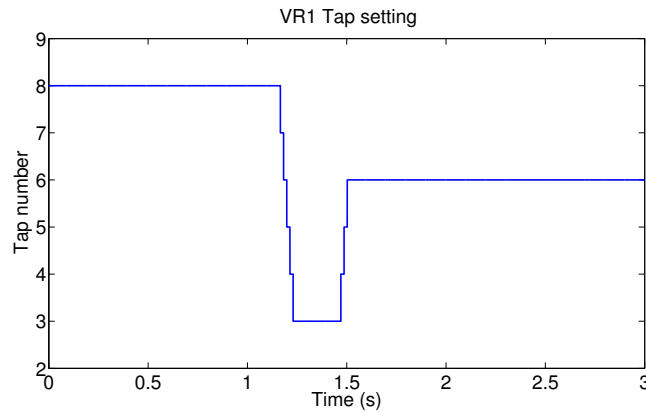

(b) Tap changes at Voltage regulator

**Figure 4.4:** Simulation 2 - Load decreases 33% at 0,6 seconds

The next graphs (Figure 4.5) show the power output of each DG located in the network.

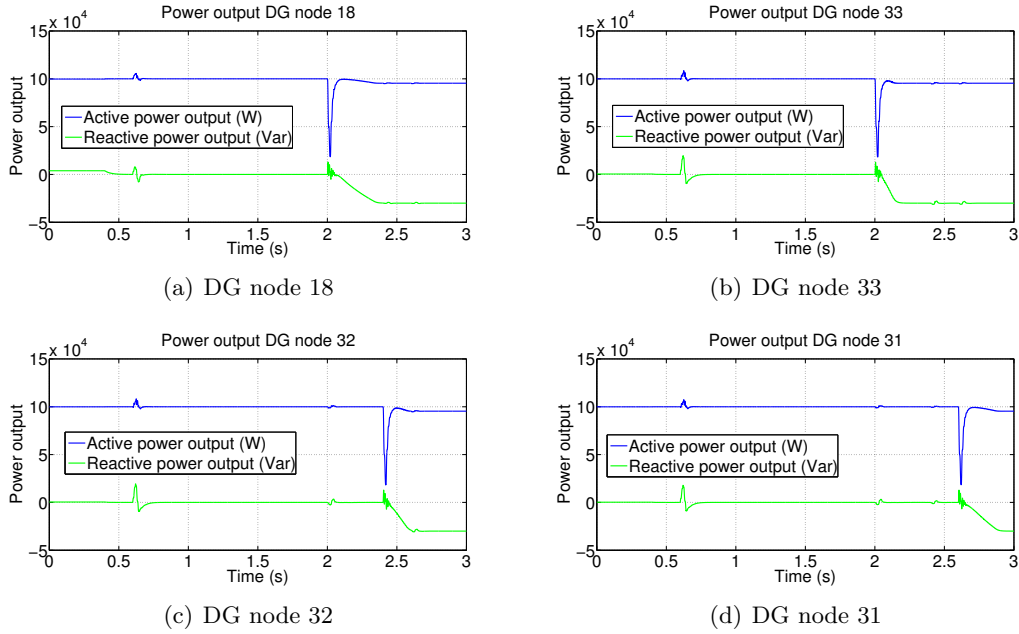

**Figure 4.5:** Simulation 2 - Output power of the different DGs

As it is shown, each DG regulates in its time defined. They regulate using voltage reference mode. Therefore, they compensate the voltage in the network through the reactive power. In this case they consume reactive power. Thus, the active power is adjusted to its correspond value.

As it is explained for the first simulation, the DGs considered in the simulations have a power output of 100 KVA, as their graphs show.

In Figure 4.6 the voltage along the feeder is plotted in order to evaluate which amount of workload the DGs and VRs have accomplished respectively and how they impact the voltage.

It is important to highlight that in this case, DGs contribute to bring the voltage within the limits but the main workload is achieved by the voltage regulator. As in the first simulation.

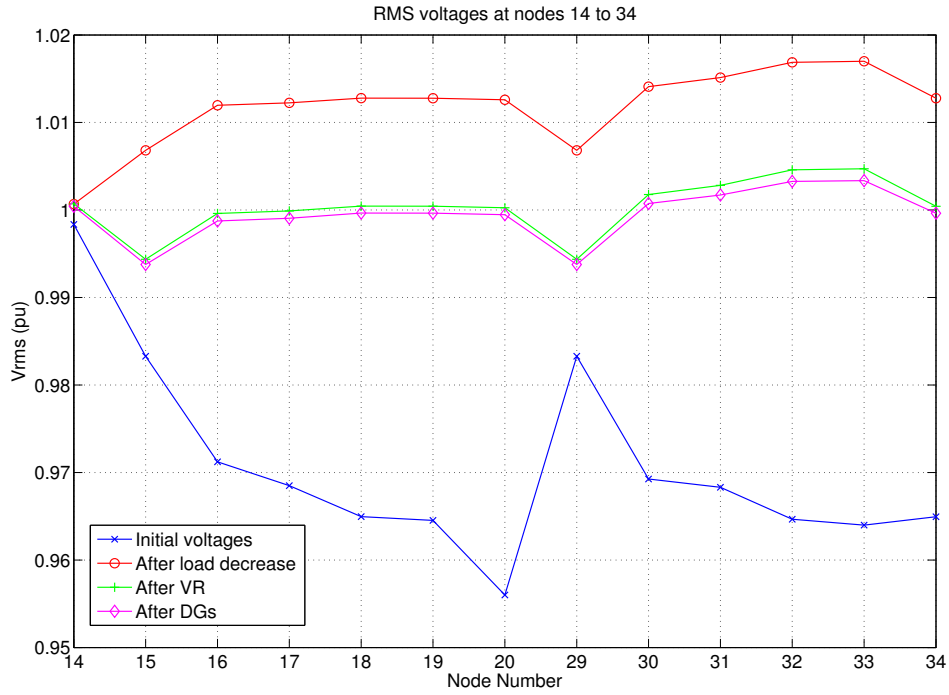

**Figure 4.6:** Simulation 2 - Voltage along the feeder - Load decreases 33% at 0,6 seconds

### 4.1.3 Discussion and conclusion

The simulations demonstrated that high penetration of distributed generation do not cause instability in a grid. A coordinated control must be achieved between DGs and the other voltage regulation devices, following the hierarchies developed in the thesis [1]. In addition, the DGs are able to collaborate in the duty of bringing the voltage within the limits when there is some kind of disturbance in the network.

Regarding location, it is proved through the simulations that the location of the DGs do not affect to the power deliver. This value is the same as long as the DGs measure the voltage at the same node.

Evaluating the workload of DGs, it must be noticed that their contribution is always less than the voltage regulators. Therefore DGs must always operate after the other devices in order to restore the remaining voltage deficit.

## 4.2 EV integration

Awareness and demand for sustainability has become a focus in 2014. As it has been said before, the importance of environmental issues have to be taken into account. For instance, EU concerning environmental impact, has defined the following targets by 2020 [25]:

- Greenhouse gas emissions 20% (or even 30%, if the conditions are right) lower than 1990.
- 20% of energy from renewables.
- 20% increase in energy efficiency

Due to these points, the electrical vehicle has had a great impact on the vehicles market lately. A lot of work is still needed to be done towards sustainability and efficiency in the field.

Although, it is also important to be aware of customers or drivers acceptance, since it is essential for the development of EVs. Therefore, their disposition and motivations to purchase these automobiles need a thorough understanding. [26]

Since a huge number of EVs are expected to be connected to the networks soon, the concept of EV charging station is a must. Stations where customers are able to charge their electrical batteries is a reality already. Nowadays, researchers in this field are working on how this stations will impact the networks.

These new EV charging stations have large amount of potential reactive power to deliver to the grid. This could be used to control and regulate the voltage. Nevertheless, they will also have a general impact on the networks. These effects could be mitigated in several ways, as the authors of [26] highlighted:

- Re-enforcing the grid infrastructure to deal with the increased loading.
- Controlling the grid loading through shared memory.
- Integrating advanced EV controlling management system through Microgrids concepts.

### 4.2.1 Impact of EV on electricity markets

The conventional design of electricity markets and the regulation of distribution networks may need to be adapted in order to facilitate an efficient integration of EVs. Nowadays, EV integration is not seen as a major problem in the short-term.

A large-scale usage of EVs will affect the current distribution network planning. The impact of EVs can lead to a significant increase in demand which will depend on the charging behaviour. Additional investments are expected to maintain system adequacy levels. [26]

EVs could present new opportunities for DSOs to solve operational problems due to congestion or voltage problems by modifying charging rates and displacing the charging times. EVs could contribute to voltage regulation by reactive power support and setting contracts between DSOs and EV aggregators could be permitted [26]. The decision to participate in the electrical market is made by the owners. The customers will decide which hours their EVs will be operating in the market. Charging and discharging batteries will reduce the life-time of the product. On the other hand, it represents an economical benefit for selling energy in the wholesale electrical market.

### 4.2.2 Profiles of EV charging station

The charge location is defined such as the area in which the EVs are charged. Three regions have been identified [26]:

- Urban: Regions with more than 250000 people.
- Sur-urban: Regions with 3000 to 250000 people.
- Rural: Regions with less than 3000 people.

For the follow simulation accomplished, a sub-urban charge station is considered with the active and reactive power profiles below (Figure 4.7). These profiles represent a regular working day (24h). EVs are mostly recharged during working hours (8h), with the peak of consumption located at 12 P.M. The profile of active demand is strongly influenced by after work hours from customers. Around 10 vehicles are assumed to be connected for this EV charging

Regarding the reactive power profile, the result of positive or negative should be clarified: negative reactive power means that the EV station has a capacitive behaviour, while a positive reactive power means an inductive behaviour.

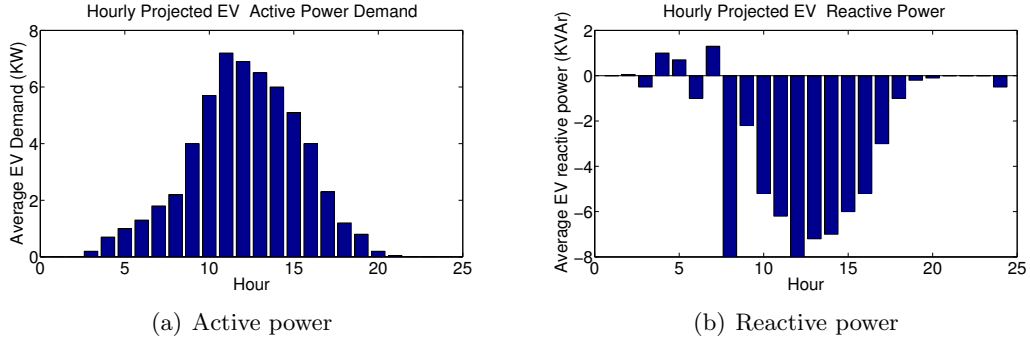

**Figure 4.7:** Hourly Projected EV Power Demand

### 4.2.3 Simulations results

Test the voltage stability of the network and evaluate how the changes in the EV's profile impact the whole network are the goals of this simulation.

For this section the network described in Appendix A (Figure A.2) is used to test EV integration. Its simulation details are presented in Appendix B, Table B.3.

In the following two graphs, the first sub-graph (Figure 4.8.a) shows the voltage profile for the EV's node (28). The second one (Figure 4.8.b) shows the behaviour of the voltage regulator (how its tap changes respond to maintain the voltage of node 28 within the limits).

It is clear that during the peak hours there is a voltage drop due to the high power consumption.

For the third graph (Figure 4.9) in this simulation, the voltage over the node 33 is plotted in order to evaluate the impact of the EV in the other branch of the network. As this flat voltage trend shows, all the changes within EV stations are responded by voltage regulator 2. Therefore the other branch of the network and specifically nodes with loads are not impacted for this EV station. Thus, the system can guaranty absolutely voltage stability even with a close EV station.



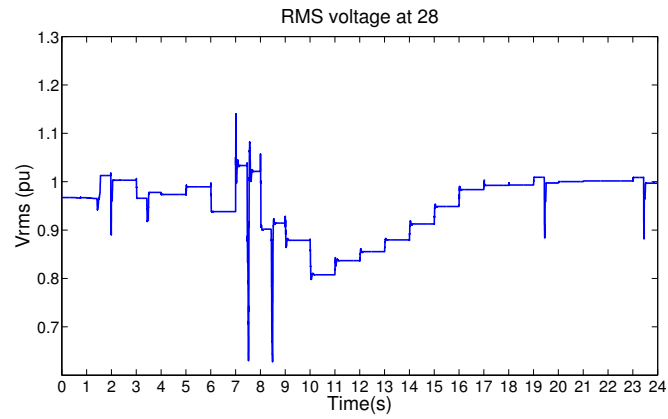

(a) Voltage at node 28

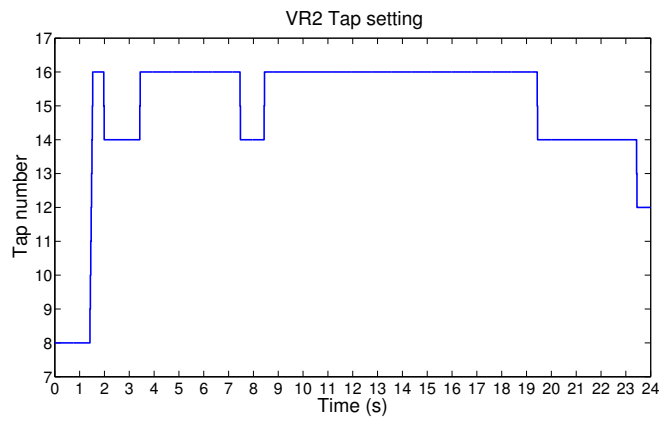

(b) Tap changes at Voltage regulator two

**Figure 4.8:** Simulation with EV integration at node 28

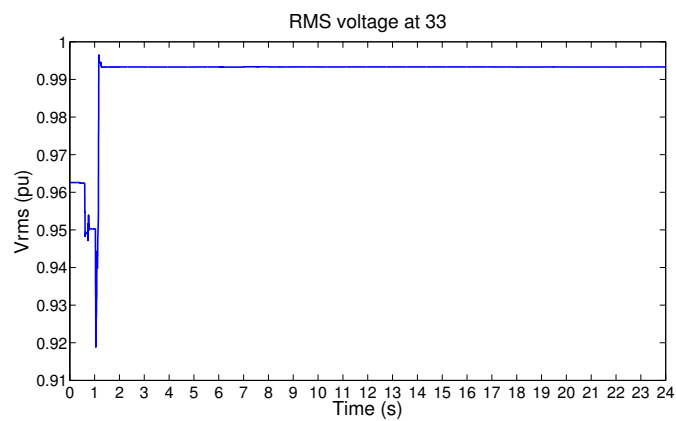

**Figure 4.9:** Voltage at node 33 with EV integration at node 28

#### 4.2.4 Discussion and conclusion

This simulation carried out and explained in this chapter has proved that integration of EV stations is successfully possible regarding stability of the network.

It is clear that profiles affect the voltage along EV's branch, reactive and active power flows impact directly the network. Nevertheless, the other branch of this network is not affected at all. This occurs since there is a voltage regulator for each part of the circuit. This means that customers from one part of a network would not be affected by an EV station located in another branch of the system.

Interaction between components (different controllers of devices) should have had a deeper evaluation in this simulation. Since there is an easy control for the EV in this model, it is a duty for a future work. Besides, developing an accurate control could produce flatter voltage profiles.

The energy storage of the EV charging stations is a topic of discussion. If the charging stations could provide this energy storage, the flexibility of the penetration of EV in the wholesale electricity market would increase. The possible negative impacts, due to last minute changing behaviour of EVs owners about their participation in voltage regulation, could be minimize with energy storage. An extra battery located in the station may use as support energy for the trades with the DSOs and will give more independence to the system.

# 5

## Coordination of OLTCs/VRs in active distribution networks

The previous chapters described and analyzed the operation of active distribution networks with a high usage of distributed generators and active loads. This chapter continues this scenario adding the OLTCs/VRs coordination.

Since reverse flows may come from: switching operations to correct the voltage along the feeder; or DGs supplying power back to the substation. The OLTCs/VRs must modify their algorithms to perform properly in this scenario. [27]

A first step in regulation and managing the voltage level, may be a decentralized local control strategy performed by the DGs units, as it is explained before in this thesis. Even though better results would be obtained with a coordinated OLTC/VR intervention. For that reason this chapter aims to develop coordination between OLTCs and VRs located in the same network. Using different procedures and configurations (testing different bandwidths and time delays for series and parallel regulation), the voltage along the feeder should be kept within the range. Besides, how their response affects the networks' stability and the order in which they operate is evaluated.

Coordination between series (OLTCs/VRs) and parallel (Capacitors Banks, DSTATCOMs and DGs) regulation devices as a whole is achieved. This chapter and analysis is based on the coordination protocol described in [1].

It is important to highlight that for this chapter, DGs operate in constant power factor mode and they do not actively regulate the voltage at PCC, as IEEE standard [28] specifies. However, even when DGs are operating in this mode, they may complicate the protection coordination and control of the voltage.

If they are not properly handled, lower reliability or even a reduction in power quality can be the result. [27]

The achievement of this coordination is carried out through simulations on a realistic MV distribution network. The Appendix A shows the networks and details used for this chapter. Also, the Appendix C presents the simulation details. The different cases tested represent: a parallel coordination between VR1 and VR2; and a series coordination between OLTC, VR3, VR1&VR2.

## 5.1 OLTC/VR features

Traditionally, distribution networks with radial configuration are regulated by an OLTC. The latter is usually located at the primary substation as, for instance model IEEE - 34 nodes, shows. Thereby, it becomes rather difficult to compensate lines radiating out from the same bus-bar since some of them are exposed to, either over-voltages or voltage drops due to the power injection by DGs. [23]

OLTCs/VRs have been widely used since the introduction of the current network structures. The main reason is that they are able to maintain the voltage range at desired levels despite input voltage changes.

Their typical response time is from 100 milliseconds to several seconds. This time concerns its current mechanical nature. Nevertheless, for this thesis, OLTCs/VRs are assumed to be power electronic devices meaning that they work faster than the conventional ones - a mechanical delay of 20 milliseconds is used in the model based on latest developments. This advance towards faster regulators makes it possible to fix problems in AC mains, regarding the necessary time to bring voltage within the limits.

Since voltage of costumers must be ensured within a standard of quality, as it is mentioned in 2.1, the design range followed is:  $\pm 5$ , 8 or 10%, with 16 taps.

### 5.1.1 Key parameters of OLTCs/VRs

There are several parameters which directly impact to these devices and they are analysed through this thesis:

#### **Bandwidth**

Range around set voltage which can be controlled with a regulator. The bandwidth setting in a multizone system decides which regulator respond first for a voltage deviation.

The modelled voltage regulators can vary the secondary side voltage to  $\pm 10\%$ , 8% or 5%. Since each device consists of 16 taps, the voltage range for each tap is 0.00625, 0.01 and 0.0125 pu respectively.

### **Time delay**

Time in seconds that a voltage regulator waits after the disturbance to avoid transient voltage fluctuation. For the completed simulations the time delays used are 0.01, 0.1 and 0.4 seconds.

### **Line compensation**

This concept is used whether a regulator is intended to control voltage at some particular point down the feeder, since the place where the failure takes place is unpredictable. Each voltage regulator will regulate within their correspondent zone, bringing the last node of each zone to the preselected value in the VR parameters.

It is a fact that some consumer points can be far from the location of its corresponding regulation device. This may create a situation where load voltage is outside the specific limits while voltage at regulators is within range. Regarding line compensation, OLTCs/VRs estimate this line voltage drop and regulate their load side voltage accordingly. Line compensation performs line corrections based on line current. The values of line reactance and resistance must be also carefully considered. [27]

Thus, line compensation concept is introduced in some of the simulations accomplished as a new improvement. This happens in order to attain more reality to the network. Thereby a new part in the Matlab model is added, and it is developed based on the equation below:

$$V_a = V_b + \Delta V \quad (5.1)$$

Where  $V_a$  represents the voltage at the VR point,  $V_b$  the voltage at the regulated node and  $\Delta V$  the voltage drop caused by the impedance and current between these two points.

## 5.2 Parallel coordination

A coordination between parallel elements is necessary in order to keep the system under control without interference between the different branches.

The modelled distribution feeder for this particular simulation includes two parallel branches led by VR1 and VR2 respectively. Figure A.2 in Appendix A shows the network used, and Table A.2. presents its details.

From now on the simulations in parallel coordination subchapter will consist on both industrial load increase by 33% at  $t=0.6$  seconds. Besides, EV's profile is considered in the networks. This causes a voltage drop below 0.95 pu in several nodes along the feeder. Following the hierarchy described in Chapter 3, the voltage is brought within the limits again.

### 5.2.1 Model without considering line compensation

A system without considering the line compensation concept is used to carry out these two simulations.

Figures 5.1.a and 5.1.b show the voltage along the feeder regarding which branch regulates first. The Appendix C (Table C.1 and C.2) presents the simulation details respectively.

The evolution of voltage profile along the feeder includes the different events that occur in the network over the simulation time. The legend in these graphs follow the order in which the events occurs.

It can be observed in Figure 5.1.a how the voltage in the Zone 3.a is brought within the limits before the rest of the nodes along the feeder, due to VR2 regulation. After this, VR1 acts to bring the voltage at the other nodes to the reference value. In Figure 5.1.b the opposite situation occurs. VR1 regulates first improving the voltage profile in zone 3.b, and VR2 regulates later bringing the voltage at node 27 and 28 within the range.

The matter is how to prioritize the regulation of the zones or if both zones can be regulated in parallel without any stability problem. Aspects such as critical loads and transient response will be key factors to draw the necessary conclusions.

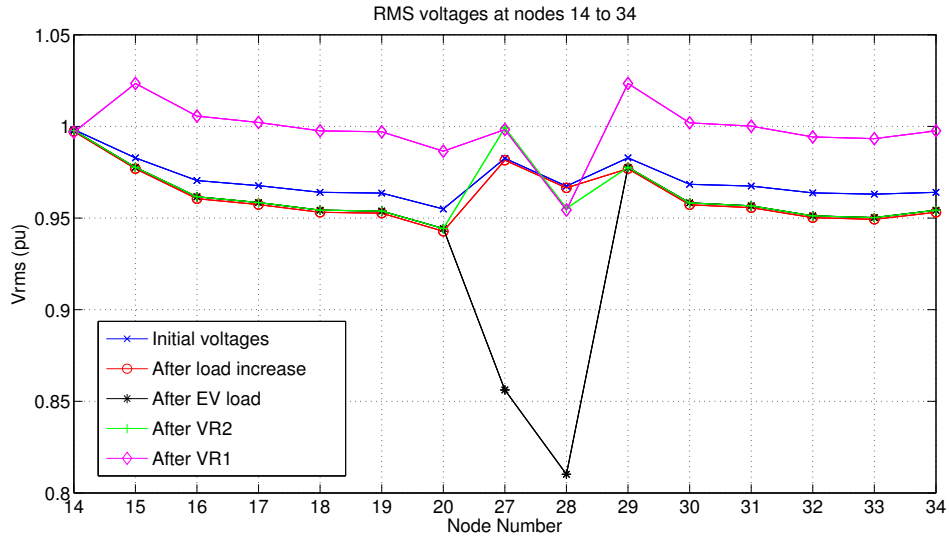

(a) Electrical vehicle branch regulates first

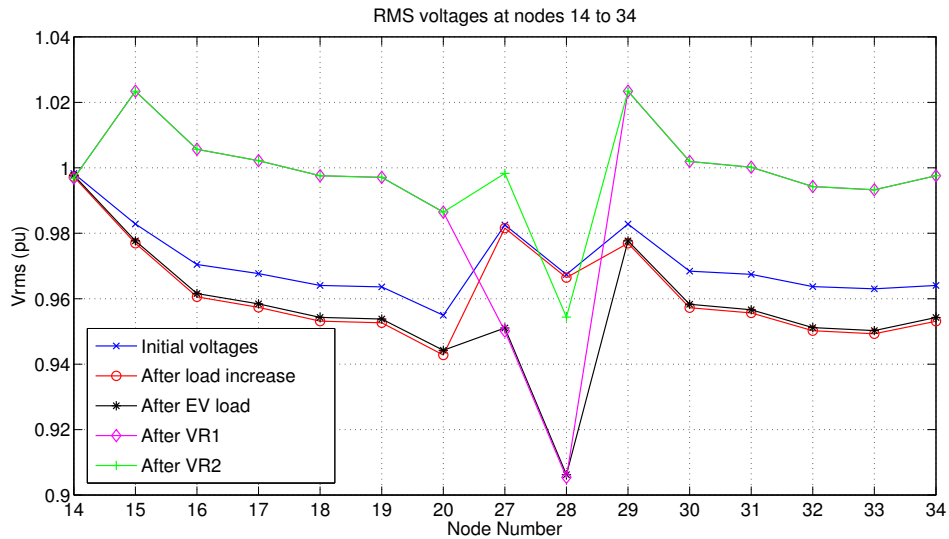

(b) Load disturbance branch regulates second

Figure 5.1: Parallel coordination simulation - Without Line compensation considered

### 5.2.2 Model considering line compensation

The following Figure 5.2 show the voltage profile along the feeder for a model involving line compensation concept. The simulations details are included in Appendix C (Table C.1 and C.2) respectively.

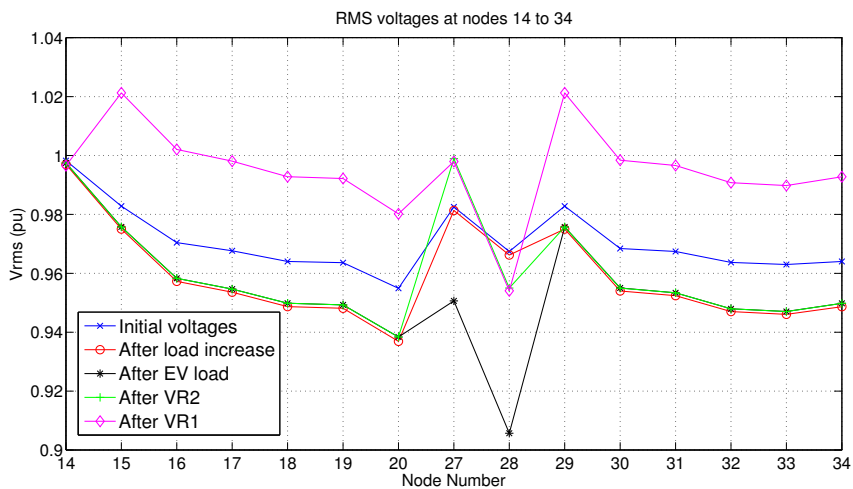

(a) Electrical vehicle branch regulates first

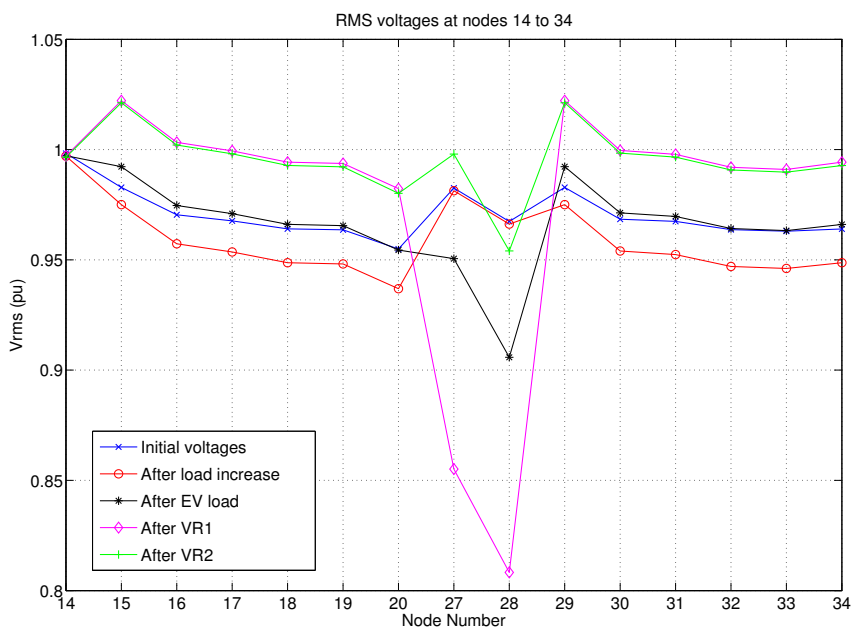

(b) Load disturbance branch regulates first

Figure 5.2: Parallel coordination simulation - Line compensation considered



The profiles are compared depending on which VR contributes first to voltage regulation, as it is explained in the previous simulation. The Figure 5.2.a regulates first the nodes 27 and 28 while Figure 5.2.b improves first the voltage profile of the zone 3.b.

### 5.2.3 Discussion and Conclusions

It can be observed that the demand of the EV station impacts significantly on the voltage profile. Much lower voltages values are obtained for nodes 27 and 28 compared to the rest of nodes. For that reason, it is concluded that VR2 (Zone 3.a) must regulate first, since the most critical points are priority.

Considering both models (line compensation and without line compensation), there is no significant difference in the voltage profile between them. It can be concluded that for local voltage control of the regulator, no line compensation is needed.

## 5.3 Series coordination

In case of series operation of OLTC/VRs, the parameters of the system (time delay and bandwidth) can be set in two ways: increasing downstream from the substation to the load side or vice versa (decreasing downstream).

The modelled distribution feeder includes an OLTC at the primary substation and three VRs between nodes 6-7, 14-15 and 14-27. Figure A.3 in Appendix A shows the network used and Table A.3 presents its details. Therefore, the tested cases represent: series coordination between OLTC, VR3 and VR1&VR2.

For the following simulations, the model settings are the same as previous ones. At  $t=0.6$  seconds both industrial loads increase by 33%. The voltage drops below 0.95 pu and the devices for voltage regulation act following the hierarchy described in Chapter 3.

It is important to highlight that from now on the voltage at node 14 is shown in order to evaluate the voltage stability in the network. Since this node is located in the middle of the grid, it is the best one to get an overview of the voltage in the network.

### 5.3.1 Model without considering line compensation

In this subchapter, two scenarios are proposed regarding whether the VRs regulate the same node (Scenario A) or different node (Scenario B) in order to investigate a new possible series control scheme regarding the different zones in the network.

For a better evaluation of the parameters and scenarios explained before, a first base case is simulated from now. This case represents a network where there is no coordination at all between devices and they all have the same operation settings.

The base case (Figure 5.3) is referred to Table C.3 in Appendix C. Here, Scenario A is considered.

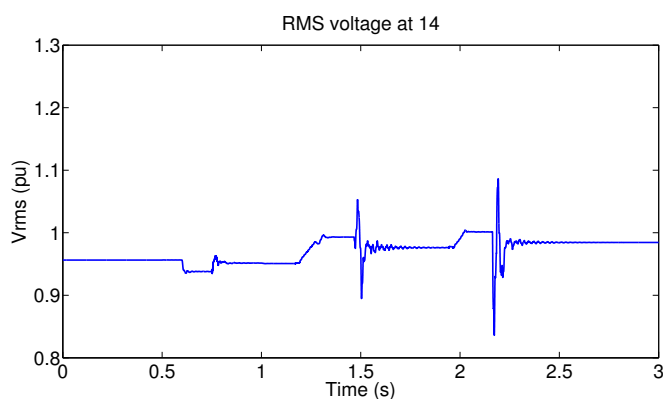
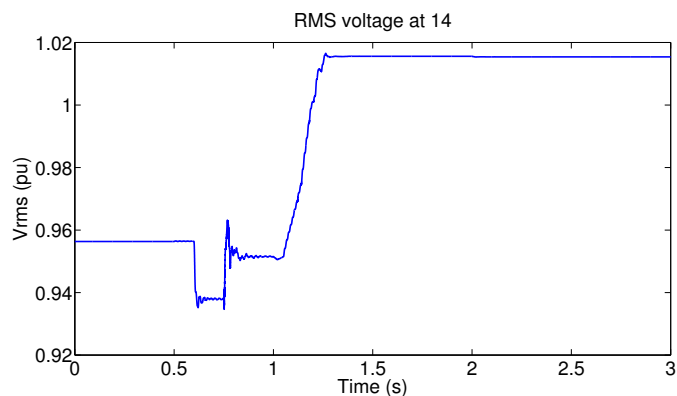

**Figure 5.3:** Voltage Node 14 – Base case

As the figure above shows, there are disturbances in the grid because of lack of coordination between the elements in the network. Thereby, their interference induces voltage peaks in the system. Also, this case is considered to be the least efficient configuration since all regulators are working at the same time without any coordination control.

The next two simulations present a regulation scheme modifying time delays downstream: OLTC -> VR3 -> VR1&VR2 and after, upstream: VR1&VR2 -> VR3 -> OLTC. The simulations details can be found in Appendix C (Table C.4 and C.5 respectively).

Figure 5.4.a and Figure 5.4.b show the voltage at node 14 for different time delay configurations:



(a) Time delay increases downstream

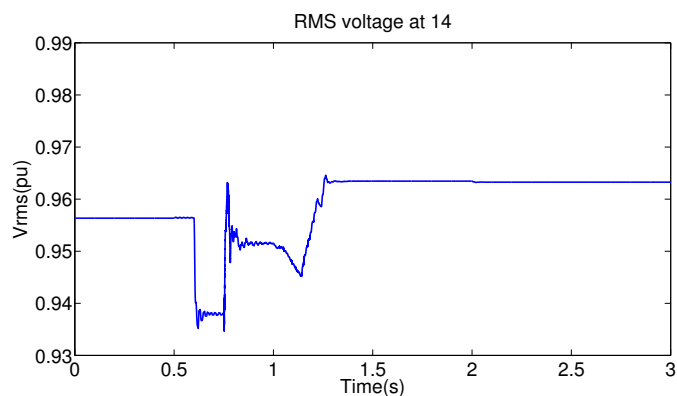

(b) Time delay decreases downstream

**Figure 5.4:** Voltage node 14 - Different time delays

After comparing the base case with the cases where a coordination between OLTC and VRs is carried out, it can be easily noticed that coordination is needed. Aside from that, comparing time delay configuration: when time delay increases downstream, the final voltage obtained is closer to rated voltage.

The two following graphs (Figure 5.5.a and Figure 5.5.b) show the voltage profile along the feeder:

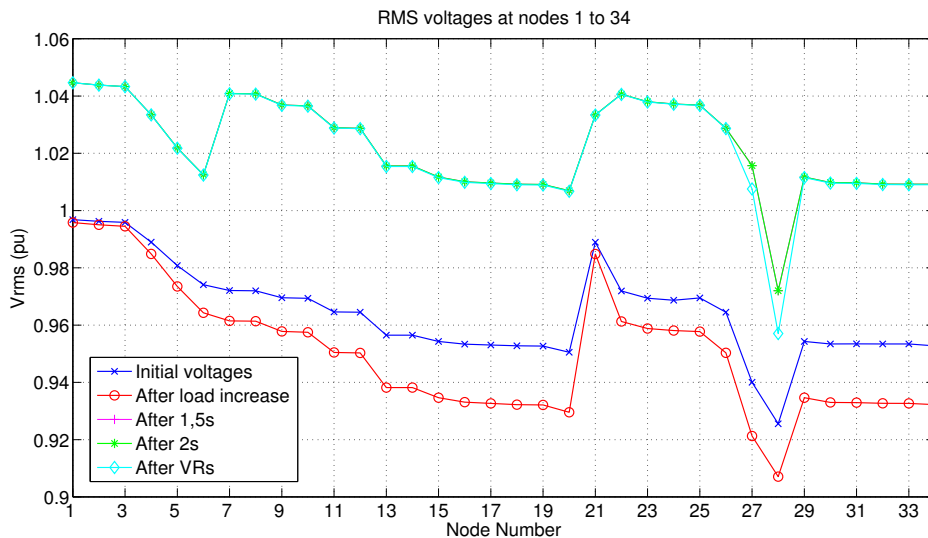

(a) Time delay increases downstream

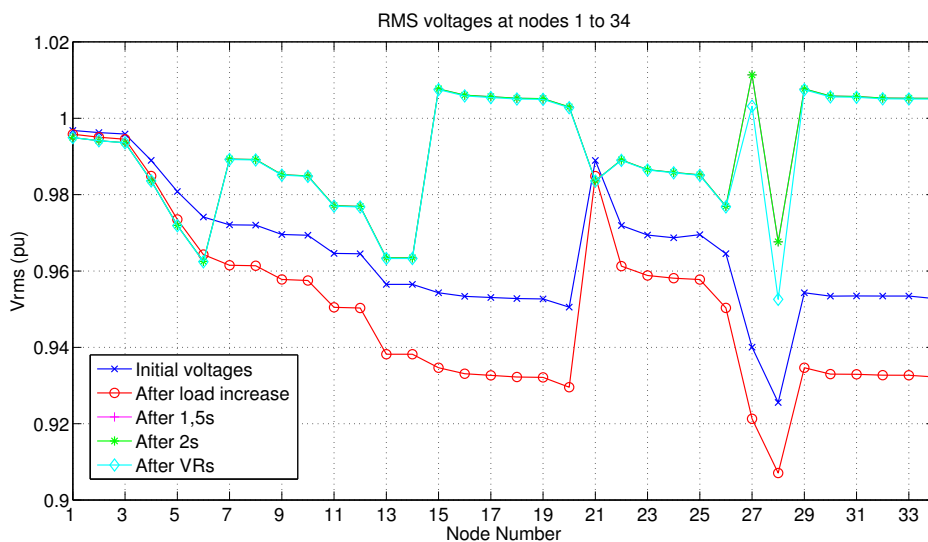

(b) Time delay decreases downstream

**Figure 5.5:** Voltage along the feeder - Different time delays

Results show that a time delay configuration increasing downstream leads to a better voltage profile along the feeder. Although the voltage stability is similar in almost all the nodes along the feeder for both cases, the upstream configuration has some drawbacks:

- Since the VR which regulates first is the one close to the load side, nodes at Zone 1 may have problems. The reference for OLTC is node 33, and since it is already within the limits, it does not act.
- The actuation of OLTC in last position can also vary the voltage of the entire network and take the voltage out of the voltage regulation bandwidth (0.95-1.05 pu).

The base case (Figure 5.6) is referred to Table C.6 in Appendix C. Here the Scenario B is considered, and the reference nodes for the voltage are depending on the zone of each VR is located. The reference nodes for OLTC, VR3, VR1 and VR2 are 6, 14, 33 and 28, respectively.

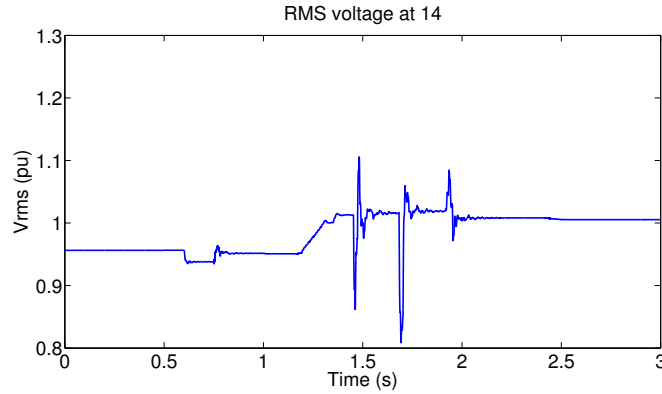

**Figure 5.6:** Voltage Node 14 – Base case

The next simulations present regulations modifying time delay values downstream: OLTC -> VR3 -> VR1 & VR2 and later upstream: VR1&VR2 -> VR3 -> OLTC. The simulations details can be found in Appendix C (Table C.7 and Table C.8 respectively).

Figure 5.7.a and Figure 5.7.b show the voltage at node 14 for the time delay configurations explained before:

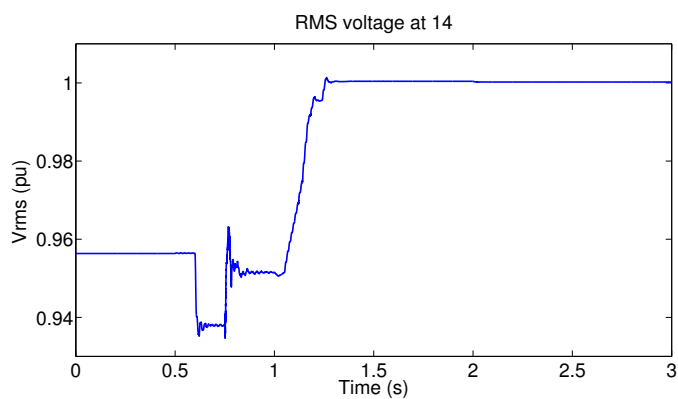

(a) Time delay increases downstream

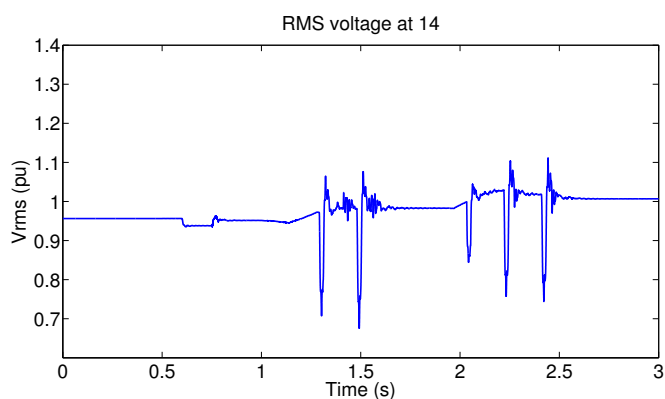

(b) Time delay decreases downstream

**Figure 5.7:** Voltage node 14 - Different time delay

As the previous simulations, a coordination control scheme is needed. Regarding time delay configuration: when time delay increases downstream, the network get the rated voltage fast while the other configuration leads to voltage peaks in the system.

The two following graphs (Figure 5.8.a and Figure 5.8.b) show the voltage profile along the feeder:

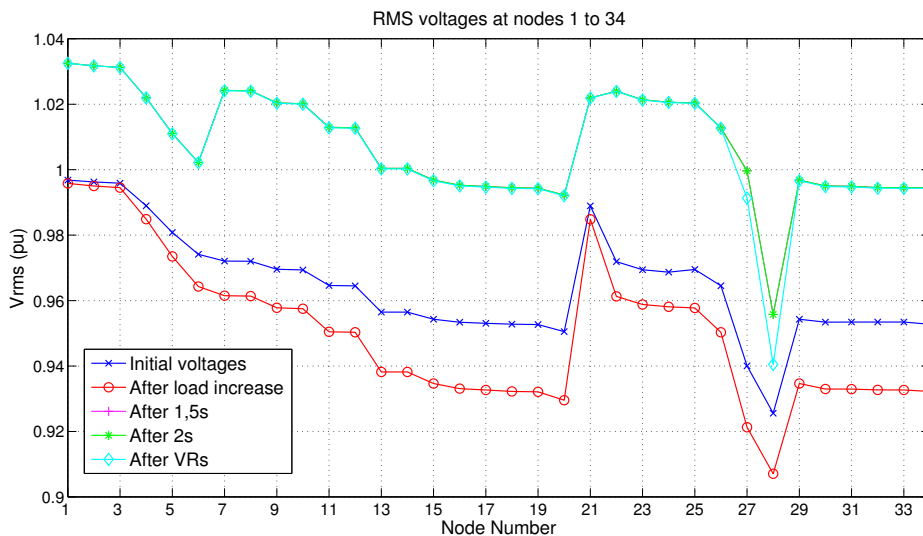

(a) Time delay increases downstream

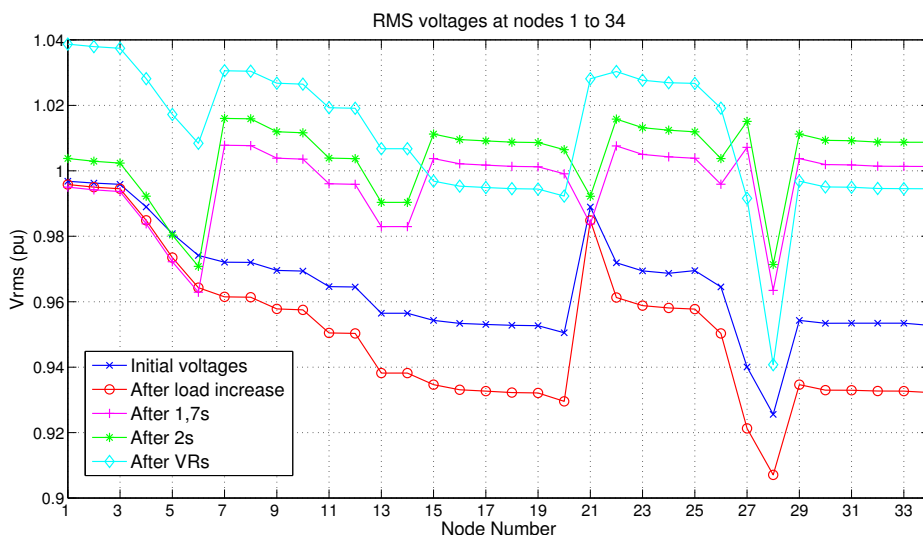

(b) Time delay decreases downstream

**Figure 5.8:** Voltage along the feeder - Different time delays

After comparing the graphs along the feeder for both configurations, it can be concluded that: when time delay increases downstream, the network got the final voltage faster; while the other configuration leads to interactions between the different zones and regulators.

The next simulations present cases modifying bandwidth values downstream: OLTC -> VR3 -> VR1 & VR2 and later upstream: VR1&VR2 -> VR3 -> OLTC. Table C.9 and Table C.10 in Appendix C content the simulations details respectively.

Figure 5.9.a and Figure 5.9.b show the voltage at node 14 for the bandwidth configurations explained before:

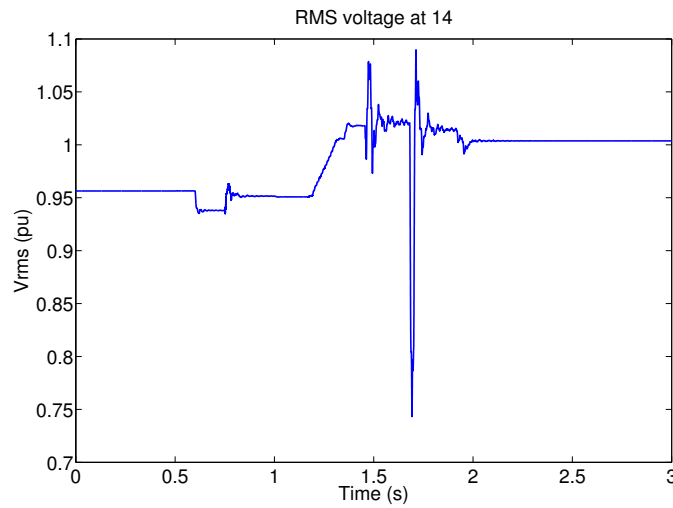

(a) Bandwidth increases downstream

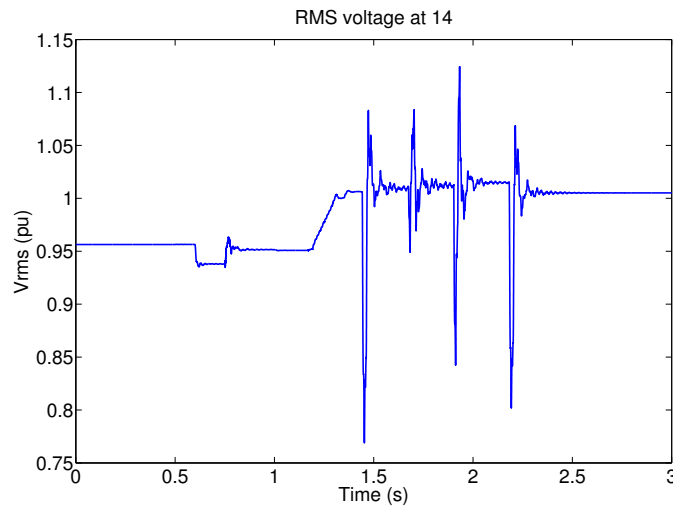

(b) Time delay decreases downstream

**Figure 5.9:** Voltage node 14 - Different bandwidth



The two following graphs (Figure 5.10.a and Figure 5.10.b) show the voltage profile along the feeder:

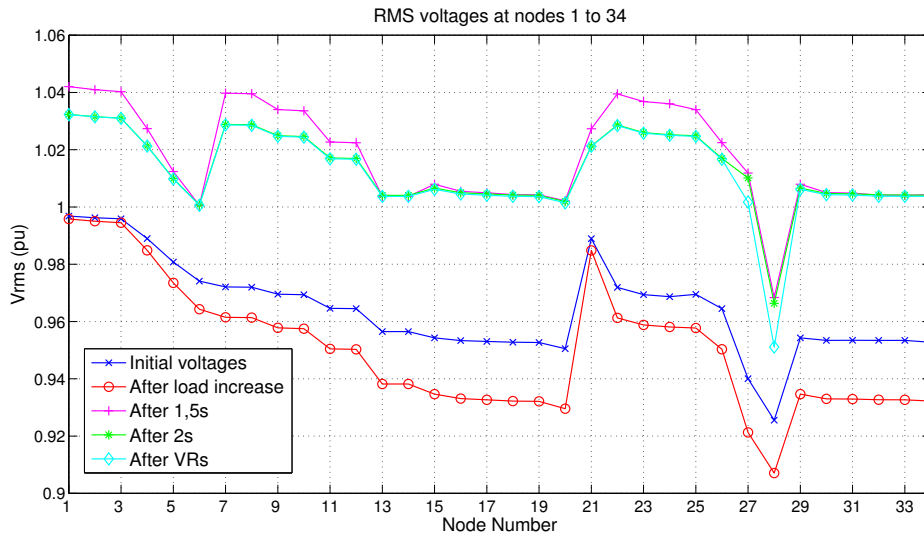

(a) Bandwidth increases downstream

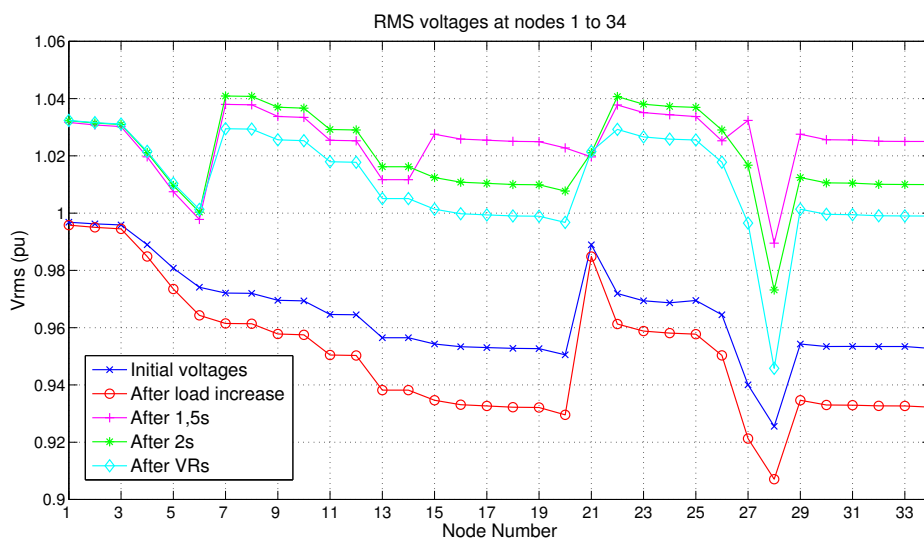

(b) Bandwidth decreases downstream

**Figure 5.10:** Voltage along the feeder - Different bandwidth

It must be noted that when bandwidth is modified, a better voltage profile is obtained for the increasing downstream configuration.

### 5.3.2 Model considering line compensation

For this chapter the concept of line compensation is introduced as new improvement, in order to attain more reality in our network. With the introduction of line compensation, scenario B will be the only one for this subchapter.

For the base case (Table C.11 in Appendix C), all the regulators in the network control their own zone bringing to a preselected voltage value each region.

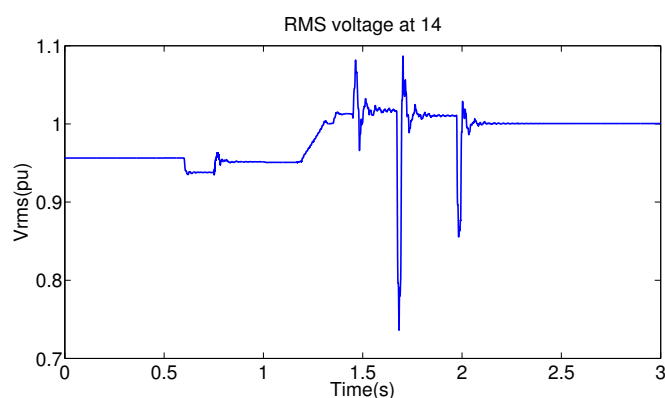
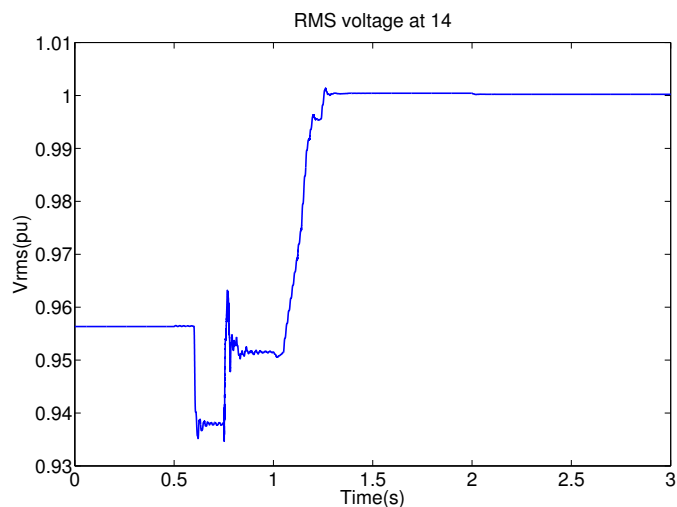

**Figure 5.11:** Voltage Node 14 – Base case

Therefore, there is interference between them since a VR tap change produces a voltage change downstream along the feeder, as it is shown in (Figure 5.11).

The next simulations present regulations modifying time delay values downstream: OLTC  $\rightarrow$  VR3  $\rightarrow$  VR1 & VR2 and later upstream: VR1&VR2  $\rightarrow$  VR3  $\rightarrow$  OLTC. The simulations details can be found in Appendix C (Table C.12 and Table C.13 respectively).

Figure 5.12.a and Figure 5.12.b show the voltage at node 14 for the time delay configurations explained before:



(a) Time delay increases downstream

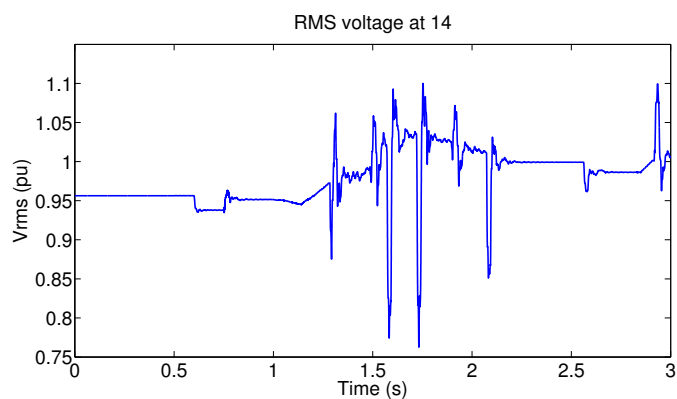

(b) Time delay decreases downstream

**Figure 5.12:** Voltage node 14 - Different time delays

Comparing time delay configuration it can be noted that: when time delay increases downstream, the network gets the rated voltage successfully; while the other configuration leads to voltage peaks in the system not even reaching the rated voltage.

The two following graphs (Figure 5.13.a and Figure 5.13.b) show the voltage profile along the feeder:

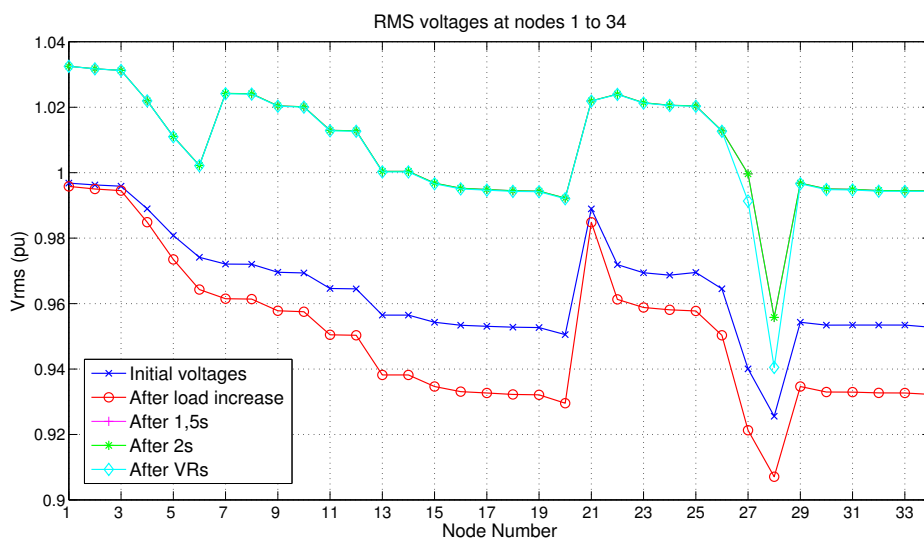

(a) Time delay increases downstream

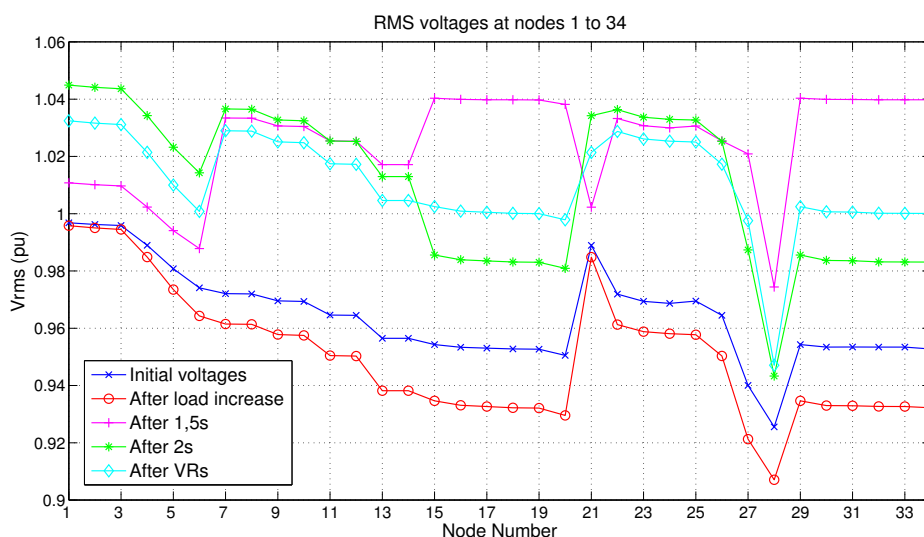

(b) Time delay decreases downstream

**Figure 5.13:** Voltage along the feeder - Different time delay

The overall voltage along the feeder gets to its final value much faster and more balance using the configuration explained in the paragraph above. Therefore the best option is that OLTC regulates first, then VR3 and VR1&VR2 the last ones (Appendix C; Table C.12).

### 5.3.3 Discussion and Conclusions

Two in-line regulators are required to maintain a good voltage profile. Series regulation should only be used when  $\Delta V$  to all downstream nodes are all positive or all negative, since it affects the voltage at all downstream nodes.

A coordination/hierarchy in the OLTC/VRs operation is needed in order to avoid interaction between them. A network without this coordination would be inefficiently operated as it is proved in the base cases of this chapter.

Regarding time delay, the completed simulations have brought up a clear coordination control in this scenario. Coordination increasing time delay downstream must be achieved. This implies that the elements placed at nodes closest to substations (PCC) must regulate first. It is also noted in the graphs along the feeder, that the configuration chosen before achieves the final voltage much faster than the other one.

Regarding bandwidth, the simulations of this chapter show that decreasing this parameter downstream along the feeder, a more stable voltage in the network is achieved.

The proposed coordination represents the first level in the voltage control. It could be applied in active networks with the integration of technologies that allow a smart management communication between the elements of the system and the system operator in the electric market as well.

More sophisticated control communication schemes are required in order to avoid problems (i.e. voltage violations) rising from the unpredictable flows or disturbances that can occur in the system.

# 6

## Conclusions, challenges and future work

### 6.1 Conclusions

The need of control and coordination between the elements in the grids has been explained and tested through this thesis, developing a new Volt/VAR scheme of hierarchies. The background defines several ways to coordinate them in order to keep the stability of the system.

A package of different conclusions are obtained:

- Integration of large amounts of DGs and active loads is feasible in ADNs as long as coordination is developed. These elements respond in a proper way to either voltage drop/rise. However, their contributions to voltage regulation compared to other regulations devices are not really relevant. In addition, the location of these elements will influence their optimal performance.
- A large-scale integration of EVs into the present distribution system could seriously affect the system reliability. The behaviour of the EV owners will define the charging patterns as well as the load flexibility.
- Coordination between OLTCs/VRs must be carried out in distribution networks. Networks not coordinated leads to a non desirable voltage profile with peaks.
- Based on the simulations results and always considering their scenario, the most suitable configurations to operate ADNs are: time delay increasing downstream; and bandwidth decreasing downstream.

- Better and flatter voltage profiles are reached when voltage regulators located at the substation regulate first and the ones at the load side last.

## 6.2 Challenges and future work

Based on the work of this thesis, some recommendations for future improvements and research are found:

- A more complex Active Distribution Network considering other devices in the grids should be accomplished in order to test a more real scenario.
- Since new elements such as EVs and DGs have come up recently in the field of voltage control, more research should be developed focusing on unnecessary components in future networks to control voltage. Providing in this way, more efficient networks in terms of costs and complexity fields.
- A more sophisticated power and voltage control of EV is necessary in order to investigate the interaction between controllers of different elements.
- The energy storage of the EV charging stations must be investigated. An extra battery located in the station could minimize the impacts of last minute changing behaviour of EVs owners about their participation in voltage regulation.
- As it is proved in this thesis, EV integration in networks is feasible regarding reactive power flows. They might have a monitoring infrastructure in order to manage their storage capacity and power flows.

# A

## Appendix A. Networks used for the simulations

Figure A.1: Network for simulations 4.1 and 4.2

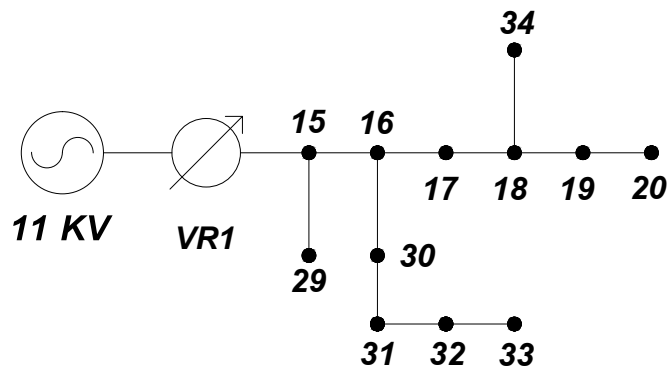

Table A.1: Network details for simulations 4.1 and 4.2

Device	Node
DG	33, 32, 31 and 18
Capacitor bank	20
DSTATCOM	16



Figure A.2: Network for simulation 4.3 and 4.4

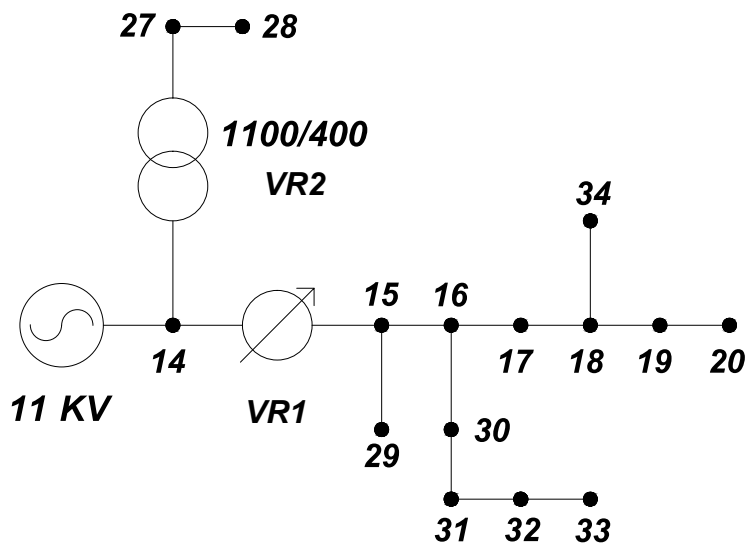

Table A.2: Network details for simulations 4.3 and 4.4

Device	Node
DG	33, 32, 31 and 18
Capacitor bank	20
DSTATCOM	16
EV station	28

Table A.3: Network details for simulations in Chapter 5

Device	Node
DG	33, 32, 31 and 18
Capacitor bank	20
DSTATCOM	16
EV station	28

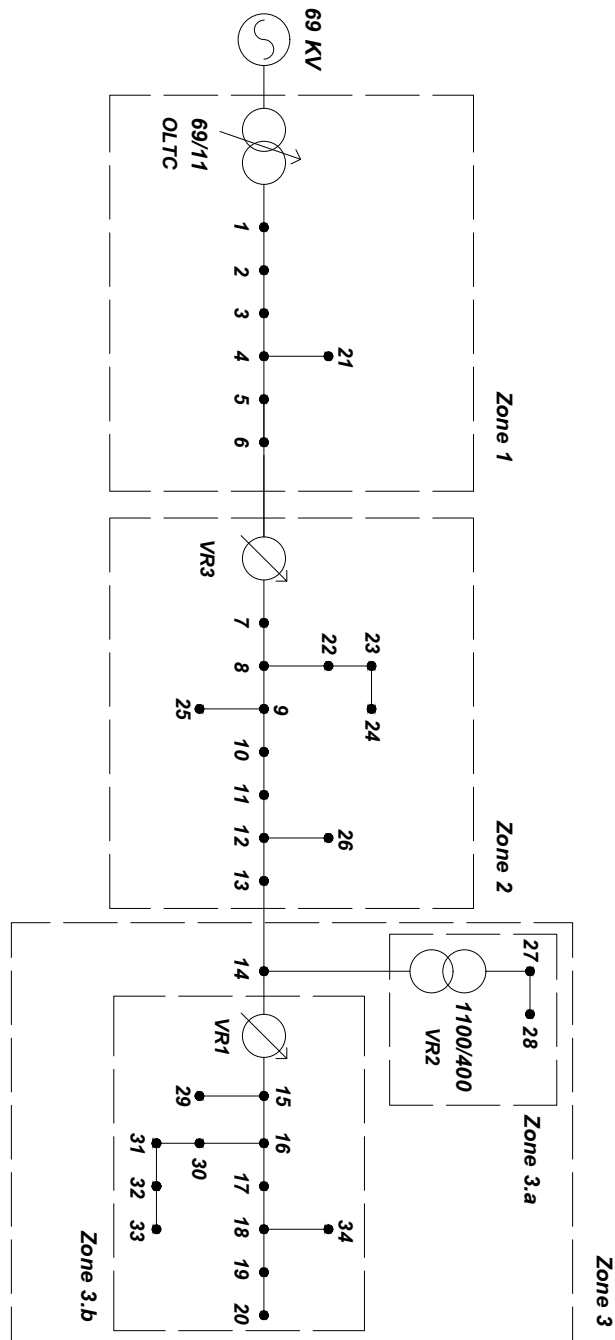

Figure A.3: Network for simulations in Chapter 5

# B

## Appendix B. Simulations details of Chapter 4

**Table B.1:** Simulation 4.1

Node of disturbance	Time of disturbance (s)	Volume of disturbance (%)
20	0,6	+33
33	0,6	+33

**Table B.2:** Simulation 4.2

Node of disturbance	Time of disturbance (s)	Volume of disturbance (%)
20	0,6	-33
33	0,6	-33

**Table B.3:** Simulation 4.3

Node of disturbance	Time of disturbance (s)	Volume of disturbance (%)
20	0,6	+33
33	0,6	+33
28	1,2,3..n..24	EV's profile

# C

## Appendix C. Simulations details of Chapter 5

**Table C.1:** Simulation 5.1

Device	Time delay (s)	Bandwidth (pu)
VR2	0,01	+0.01
VR1	0,15	+0.01

**Table C.2:** Simulation 5.2

Device	Time delay (s)	Bandwidth (pu)
VR2	0,15	+0.01
VR1	0,01	+0.01

**Table C.3:** Simulation 5.3

Device	Reference node	Time delay (s)	Bandwidth (pu)
OLTC	33	0,15	+0.01
VR3	33	0,15	+0.01
VR2	28	0,15	+0.01
VR1	33	0,15	+0.01

**Table C.4:** Simulation 5.4

Device	Reference node	Time delay (s)	Bandwidth (pu)
OLTC	33	0,01	+0.01
VR3	33	0,1	+0.01
VR2	28	0,4	+0.01
VR1	33	0,4	+0.01

**Table C.5:** Simulation 5.5

Device	Reference node	Time delay (s)	Bandwidth (pu)
OLTC	33	0,4	+0.01
VR3	33	0,1	+0.01
VR2	28	0,01	+0.01
VR1	33	0,01	+0.01

**Table C.6:** Simulation 5.6

Device	Reference node	Time delay (s)	Bandwidth (pu)
OLTC	6	0,15	+0.01
VR3	14	0,15	+0.01
VR2	28	0,15	+0.01
VR1	33	0,15	+0.01

**Table C.7:** Simulation 5.7

Device	Reference node	Time delay (s)	Bandwidth (pu)
OLTC	6	0,01	+0.01
VR3	14	0,1	+0.01
VR2	28	0,4	+0.01
VR1	33	0,4	+0.01

**Table C.8:** Simulation 5.8

Device	Reference node	Time delay (s)	Bandwidth (pu)
OLTC	6	0,4	+0.01
VR3	14	0,1	+0.01
VR2	28	0,01	+0.01
VR1	33	0,01	+0.01

**Table C.9:** Simulation 5.9

Device	Reference node	Time delay (s)	Bandwidth (pu)
OLTC	6	0,15	+0.00625
VR3	14	0,15	+0.01
VR2	28	0,15	+0.0125
VR1	33	0,15	+0.0125

**Table C.10:** Simulation 5.10

Device	Reference node	Time delay (s)	Bandwidth (pu)
OLTC	6	0,15	+0.0125
VR3	14	0,15	+0.01
VR2	28	0,15	+0.0625
VR1	33	0,15	+0.0625

**Table C.11:** Simulation 5.11

Device	Reference node	Time delay (s)	Bandwidth (pu)
OLTC	LN (6)	0,15	+0.01
VR3	LN (14)	0,15	+0.01
VR2	LN (28)	0,15	+0.01
VR1	LN (33)	0,15	+0.01

**Table C.12:** Simulation 5.12

Device	Reference node	Time delay (s)	Bandwidth (pu)
OLTC	LN (6)	0,01	+ -0.01
VR3	LN (14)	0,1	+ -0.01
VR2	LN (28)	0,4	+ -0.01
VR1	LN (33)	0,4	+ -0.01

**Table C.13:** Simulation 5.13

Device	Reference node	Time delay (s)	Bandwidth (pu)
OLTC	LN (6)	0,4	+ -0.01
VR3	LN (14)	0,1	+ -0.01
VR2	LN (28)	0,01	+ -0.01
VR1	LN (33)	0,01	+ -0.01

# Bibliography

- [1] J. Barr, “Integration of Distributed Generation in the Volt/VAR Management System for Active Distribution Networks” (2013).
- [2] E. Lakervi, E. J. Holmes, “Electricity Distribution Network Design” (1995).
- [3] H. Andrei, G. Chicco, “Identification of the Radial Configurations Extracted From the Weakly Meshed Structures of Electrical Distribution Systems” Vol. 55 (2008) (No 4).
- [4] Eurelectric, “Active distribution system management – a key tool for the smooth integration of distributed generation, Technical report” (2013).
- [5] J. Machowski, J. W. Bialek, J. R. Bumby, “Power System Dynamics Stability and Control” (2008).
- [6] I. Roytelman, B. K. Wee, R.L.Lugtu, “Volt/VAR control algorithm for modern distribution management system” Vol.10 (1995) (No 3).
- [7] I. Roytelman, B. K. Wee, R.L.Lugtu, “Application guide to the European Standard EN 50160 on: Voltage characteristics of electricity supplied by public distribution systems” (1995).
- [8] D. T. Rizy, “IEEE PES Volt/VAR Control Task Force (VVCTF)” (2011).
- [9] E. Jauch, “Smart Grid Volt/Var Management: Challenges of Integration Distribution DG” (2012).
- [10] D. M. Geibel, “Load Tap Changers, Theory and application” (2013).
- [11] [www.tanandsons.com](http://www.tanandsons.com), “Image OLTC/Voltage regulator”.  
URL <http://www.tanandsons.com/services/images/V-Tap2.jpg>
- [12] [www.directindustry.com](http://www.directindustry.com), “Characteristic curve of STATCOM”.  
URL [http://img.directindustry.com/images\\_di/photo-g/pole-mounted-capacitor-banks-70728-2773879.jpg](http://img.directindustry.com/images_di/photo-g/pole-mounted-capacitor-banks-70728-2773879.jpg)



- 
- [13] S. of Lab-Volt Ltd., “Static Synchronous Compensator (STATCOM)” (2012).
- [14] ocw.uc3m.es, “Image of capacitor bank”.  
URL [http://ocw.uc3m.es/ingenieria-electrica/operacion-y-control-de-sistemas-electricos/OCW\\_II\\_OCSE\\_RT/img34.png](http://ocw.uc3m.es/ingenieria-electrica/operacion-y-control-de-sistemas-electricos/OCW_II_OCSE_RT/img34.png)
- [15] www.reinhausen.com, “Parts of Voltage regulator”.  
URL [http://www.reinhausen.com/Portaldata/1/Resources/tc/products/oltc/vacutap\\_vv/Vacutap\\_\\_\\_VV.jpg](http://www.reinhausen.com/Portaldata/1/Resources/tc/products/oltc/vacutap_vv/Vacutap___VV.jpg)
- [16] S. Bisanovic, M. Hajro, M. Samardzic, “One approach for reactive power control of capacitor banks in distribution and industrial networks” Vol. 60 (2014).
- [17] A. T. Haskew, S. Li, L. Xu, “Control of VSC-based STATCOM using conventional and direct-current vector control strategies ” (2013).
- [18] X. Feng, T. Wei, “Study on voltage quality of distribution network with high penetration of DG” (2010).
- [19] D. Christian, C. Abbey, S. Jupe, B. Buchholz, M. Khattabi, F. Pilo, “Development and operation of active distribution networks: results of CIGRE C6.11 working group” (2011).
- [20] W. H. Kersting, “Radial distribution test feeders. IEEE” (2000).
- [21] M. Ettehadi, S. VaezZadeh, H. Ghasemi, “DG placement in distribution networks considering voltage stability” (2012).
- [22] M. Hlatshwayo, S. Chowdhury, S. Chowdhury, “Impacts of DG Penetration in the Reliability of Distribution Systems” (2010).
- [23] R. Caldon, M. Coppo, R. Sgarbossa, R. Turri, “A Simplified Algorithm for OLTC Control in Active Distribution MV Networks” (2013).
- [24] S. Al Kaabi, H. H. Zeineldi, V. Khadkikar, “Planning Active Distribution Networks Considering Multi-DG Configuration” Vol. 29, No. 2 (2014).
- [25] E. Union, “European Union targets” (2014).  
URL <http://ec.europa.eu/europe2020/europe-2020-in-a-nutshell/targets>
- [26] J. Pecas Lopes, “Integration of electric vehicles in electric power systems” (2013).
- [27] I. Ljubomir A. Kojovic, Senior Member, “Coordination of Distributed Generation and Step Voltage Regulator Operations for Improved Distribution System Voltage Regulation” (2006).
- [28] IEEE, “IEEE Application Guide for IEEE Std 1547, IEEE Standard for Interconnecting Distributed Resources With Electric Power Systems” (2008).