

VIII. Current Trends

著者	Pangalangan Raul C.
権利	Copyrights 日本貿易振興機構（ジェトロ）アジア 経済研究所 / Institute of Developing Economies, Japan External Trade Organization (IDE-JETRO) http://www.ide.go.jp
journal or publication title	The Philippine Judicial System
volume	5
page range	97-107
year	2001
URL	http://hdl.handle.net/2344/00015202

VIII. CURRENT TRENDS

A. Judicial Education

No less than the Philippine Constitution requires members of the Judiciary to be persons of “*proven competence, integrity, probity and independence.*” (CONSTITUTION, Art. VIII, Sec. 6 [3]) The Constitutional requirement as to the competence of members of the Judiciary is further supported by the Canons of Judicial Ethics that requires judges to be faithful to the law and maintain professional competence in it.

Verily, the competence of judges is a requirement that is founded on both statutory law and necessity or expediency. Unlike ordinary public officers, the members of the judiciary assume a higher position in the political hierarchy. Necessarily, therefore, higher requirements are imposed upon such officers of the court.

In order to ensure that the members of the judiciary meet the standards of competence, the Judicial Branch of government, through the initiation of the Supreme Court, promotes education and awareness among its ranks via a system of continuing judicial education. At the helm of the Supreme Court’s efforts in the promotion of continuing legal and judicial education is the Philippine Judicial Academy (PHILJA).

Originally, the PHILJA was created by virtue of an Administrative Order issued by the Supreme Court in 1996. PHILJA became legally institutionalized with the enactment of Republic Act No. 8557 (1998). The rationale for the creation of the PHILJA is to formulate and implement an institutionalized, integrated, professionalized and continuing system of judicial education for justices, judges, court personnel and lawyers.

In view of its mandate, the PHILJA was tasked to devise and implement a course curriculum for both the formal and non-formal judicial education of lawyers and judges. It provides trainings, seminars, teach-ins and other similar methods of instruction covering various areas of the law and jurisprudence for the benefit of lawyers and judges. (R.A. 8557, Secs. 1 & 2)

The following are the specific projects undertaken by the Supreme Court in line with the continuing judicial education program:

1. Training the Trainers Program for Family Courts.

This training was conducted in line with the mandate of R.A. 8369 (Family Courts Act of 1997), and was intended to provide training to individuals who would in turn, train and orient the judges and court personnel assigned in the designated Family Courts.

2. Gender Sensitivity Seminar for the Philippine Judiciary.

This seminar was conducted to enlighten judges on the issues of gender equality and sensitivity, thereby making the courts more conscious in the application of laws that promote the welfare of children and women, both of whom are recognized in this jurisdiction are deserving of more protection under the law.

3. Workshop of Judges on the Anti-Domestic Violence Bill

In line with the protectionist policy of Philippine law with respect to women, certain members of Congress proposed a bill which will criminalize the commission of violence against female spouses committed in the family home. The workshop provided judges with the opportunity to study the bill in anticipation of its eventual enactment into law.

4. Workshop on Video-Conferencing in Trial Courts Involving the Testimony of Children

This workshop focused on a new method currently being explored in regard to the taking of testimony of children in legal proceedings. Considering the trauma caused to children who serve as witnesses in legal proceedings, it is proposed that their testimonies be taken through video; thus, obviating with their physical presence in the court room. This innovation is in line with the policy of promoting the rights of the child.

5. Securities & Exchange (SEC) Program

This is a program conducted for the hearing officers of the SEC to improve their competence in performing their quasi-judicial functions.

Recently, the PHILJA has embarked on the computerization of its files, circulating the so-called “PHILJA Updates” in electronic format, in collaboration with CD Asia. The Updates contain current statutes, administrative proceedings against officers of the court, and an update on the administrative circulars / memoranda issued by the Supreme Court. Likewise, computerization of the records of the courts is on-going.

These computerization projects support the efforts of the Supreme Court towards full computerization of records in the various courts. In 1989, the Supreme Court installed the “Case Administration System”, which is the computerized system for information storage and retrieval, for use in the management of the court’s docket. There is also, at present, a web site devoted exclusively to the Supreme Court. With the joint efforts of the Supreme Court and the PHILJA, a fully-computerized court system would soon be forthcoming.

B. TQM and TPCMS

Apart from the foregoing, PHILJA has introduced seminars on the so-called “*Total Quality Management (TQM) for Trial Court Judges and Court Personnel.*” TQMs were designed to strengthen the managerial capabilities of judges such that there would be an improvement in the quality of judicial service received by the general public. In order to facilitate the learning of the judges and court personnel, TQM Seminars adopt a participatory rather than a hierarchical approach. Considering the practicality of the methodology used in TQM Seminars, it would be easier to achieve the goal of improving the quality of service delivered by the judiciary.

Coupled with the TQMs, the Supreme Court devised the Trial Court Performance Standards and Measurement System (TPCMS) that set five (5) key areas by which judges would gauge the standards of their performance. These five (5) standards include:

- Access to justice
- Expedition and Timeliness
- Equality, Fairness and Integrity
- Independence and Accountability
- Public Trust and Confidence

C. Private Initiatives in Support of Judicial Education

Aside from the initiatives of the Supreme Court, the promotion of judicial education in the Philippine bench and bar is actively supported by private agencies that include the *United Nations Development Program (UNDP)*; *United States Agency for International Development (USAID)* through *The Asia Foundation (TAF)* and the *Trade and Investment Policy Analysis and Advocacy Support (TAPS)*. In addition to the foregoing, the *World Bank (WB)* also grants appropriate funding for various projects designed to enhance the administration of justice in the Philippine court system.

Among the above-mentioned entities, it is the UNDP that is most active in providing support to the judicial education efforts of the Supreme Court. In June 1999, the UNDP in collaboration with PHIL-EXPORT TAPS, funded the “Pilot Project on Mediation / Conciliation” within selected RTCs and MTCs. This project was attended by judges, clerks of court and prospective mediators. As a result thereof, twenty (20) out of the twenty-eight trainees passed the examinations, and have now qualified as mediators.

It was also last year that the UNDP sponsored the “Management Study of the Judiciary,” a component of the principal project called the SC-UNDP Technical Assistance to the Philippine Judiciary on Justice and Development, which was completed through the initiative of the PHILJA. This project consisted of a report on the organizational structure and management procedures, identification of the problems, capability gaps and overlapping functions within the entire spectrum of the Philippine court system. The project rationale of the Management Study of the Judiciary can be summarized, to wit:

- a. Manage the administrative processes with maximum efficiency and effectiveness without interfering with the adjudication of cases;
- b. Create a new environment in the administration of courts where good management practices can thrive to enhance judicial decision-making;
- c. Strengthen the judicial system so that it can quickly and easily adapt to changing circumstances and confront future changes, e.g., increase in population, increase in cases filed, complexity of the rules of procedure and the cases filed; and

- d. Develop at least a 1-year, a 3-year, and a 5-year development plan, to keep them in tune with the times.

D. Continuing Re-Organization of Courts and Speedy Disposition of Cases

Recent trends in the Philippine court system also witnessed the “specialization” of courts into specific fields of law wherein they can exercise their powers of adjudication. This “specialization” is intended to enhance general court efficiency in the administration of justice in the Philippines.

Among the concrete measures taken toward such “specialization” is the creation of Family Courts under R.A. No. 8369 (“Family Courts Act of 1997”). Pursuant to this law, certain second-level courts (RTCs) were assigned to exclusively hear cases pertaining to Family Law. These cases include domestic violence against women, child abuse and annulment of marriages.

On October 2, 1995, Administrative Order No. 113-95 of the Supreme Court designated special courts to hear and decide cases involving violations of the Intellectual Property Rights, as contained in the pertinent laws, i.e., Revised Penal Code (Arts. 188 & 189); R.A. 165 & 166; PD 49; and RA 8293, An Act Prescribing the Intellectual Property Code.

There are also first-level and second-level courts (RTCs and MTCs) that are assigned to hear and try criminal actions for violations of RA 6425 or the “Dangerous Drugs Act of 1972.” Considering that the court dockets are usually clogged, it was deemed expedient to assign specific courts to hear drug-related cases.

On April 21, 1993, by virtue of Administrative Circular No. 64-93, certain MetTcs, MTCCs, MTCs, and MCTCs were constituted to hear and decide cadastral or land registration cases covering lots over which there is no controversy or opposition, or contested lots the value of which does not exceed PhP 20,000.00. Like in the case of the courts handling purely drug cases, these courts were constituted to decongest the courts dockets that are clogged with such cases.

On 21 November 2000, by virtue of Administrative Matter No. 00-11-03, certain Regional Trial Courts were designated to try and decide Securities and Exchange Commission cases enumerated in Section 5 of Presidential Decree No. 902-A (Reorganization of the Securities and Exchange Commission).

To further reinforce the “specialization” of the courts in the attempt to decongest the clogged dockets and enhance efficiency in the administration of justice, the Congress enacted R.A. 8493, the “Speedy Trial Act of 1998.” This law was enacted not only upon considerations of practical expediency, but more importantly, by virtue of the express provision of the Constitution that states:

“All persons shall have the right to a speedy disposition of their cases before all judicial, quasi-judicial, or administrative bodies.” (CONSTITUTION, Art. III, Sec. 16)

Under the Speedy Trial Act, the in criminal cases cognizable by the MTC, MCTC, MeTC, RTC and the Sandiganbayan, pre-trial shall be mandatory. In crimes where the penalty prescribed by law does not exceed six (6) months imprisonment or a fine of PhP 1,000.00 or both, the judge, upon consultation with the prosecutor and counsel for the accused, shall set the case for continuous trial on a weekly or the short time possible, and in no case shall the trial period exceed 180 days from the first day of trial. There shall be a 30-day limit from the filing of the information to the appearance of the accused before the court. Where an accused pleads not guilty to the crime, he shall have 15 days within which to prepare for the trial that shall commence within 30 days from arraignment. After judgment has been rendered and the accused moves for a new trial, the same will commence within 30 days from the order granting the prayer for new trial that shall not exceed 180 days therefrom. Failure to observe the time limits set by the law warrants the dismissal of the case. The provisions of the “Speedy Trial Act” have been incorporated in the Revised Rules of Criminal Procedure as interpreted by Circular No. 38-98.

E. Mandatory Continuing Legal Education (MCLE)

In Bar Matter No. 850, the Supreme Court passed a *Resolution Adopting the Rules on Mandatory Continuing Legal Education for Members of the Integrated Bar of the Philippines*.

The continuing legal education is required of all members of the Integrated Bar of the Philippines (IBP) to ensure that they keep themselves updated of recent law and jurisprudence, maintain the ethics of the profession, and augment the standards of law practice. Under the MCLE, the members of the IBP are required to complete every three (3) years at least thirty six (36) hours of continuing legal education activities approved by the MCLE Committee. A member who does not attend the MCLE, and

after given the opportunity to explain the reason for failing to attend the same, still fails to do so, may be considered a delinquent member. These are efforts to further improve the level of competence among the ranks of judges.

F. Conclusion

The pursuit of continuous development is the thrust of the Philippine Judiciary which is being pursued with greater determination in recent times. Toward this goal, the Supreme Court is being actively supported by private international organizations such as the UNDP.

The long-term objective of this pursuit is to enhance the administration of justice in the Philippines. Apart from education, the Supreme Court and the Legislative Department, have taken measures towards “specialization” – that is, assigning courts to specialize in particular areas of adjudication. Subsequently, it is hoped that the dockets of the courts would eventually be decongested so that justice for the greater number would truly be served. In addition, stringent rules now require that cases be disposed within specific time frame/s in consonance with the precept that “justice delayed is justice denied.”

As regards the trend in cases brought before the courts, aside from the usual civil and criminal cases, there are now cases that are filed for the purpose of preserving the rights of women and children as enunciated in express laws. The child/women-protectionist policy of the State has allowed the introduction of new cases over which the courts exercise adjudicatory powers in order to guarantee a just and humane society whereby parties seemingly unequal in power are placed on an equal footing.

With the growing complexity of legislation – i.e., laws on electronic commerce (E-commerce), revision of criminal laws, etc.- it is expected that there would be also be a growing complexity in the quality of cases handled by Philippine courts. There is, thus, the need to innovate and adopt more advanced technology to enable the local courts to cope with the challenges that lie ahead.

TOTAL COURT SYSTEM IN THE PHILIPPINES

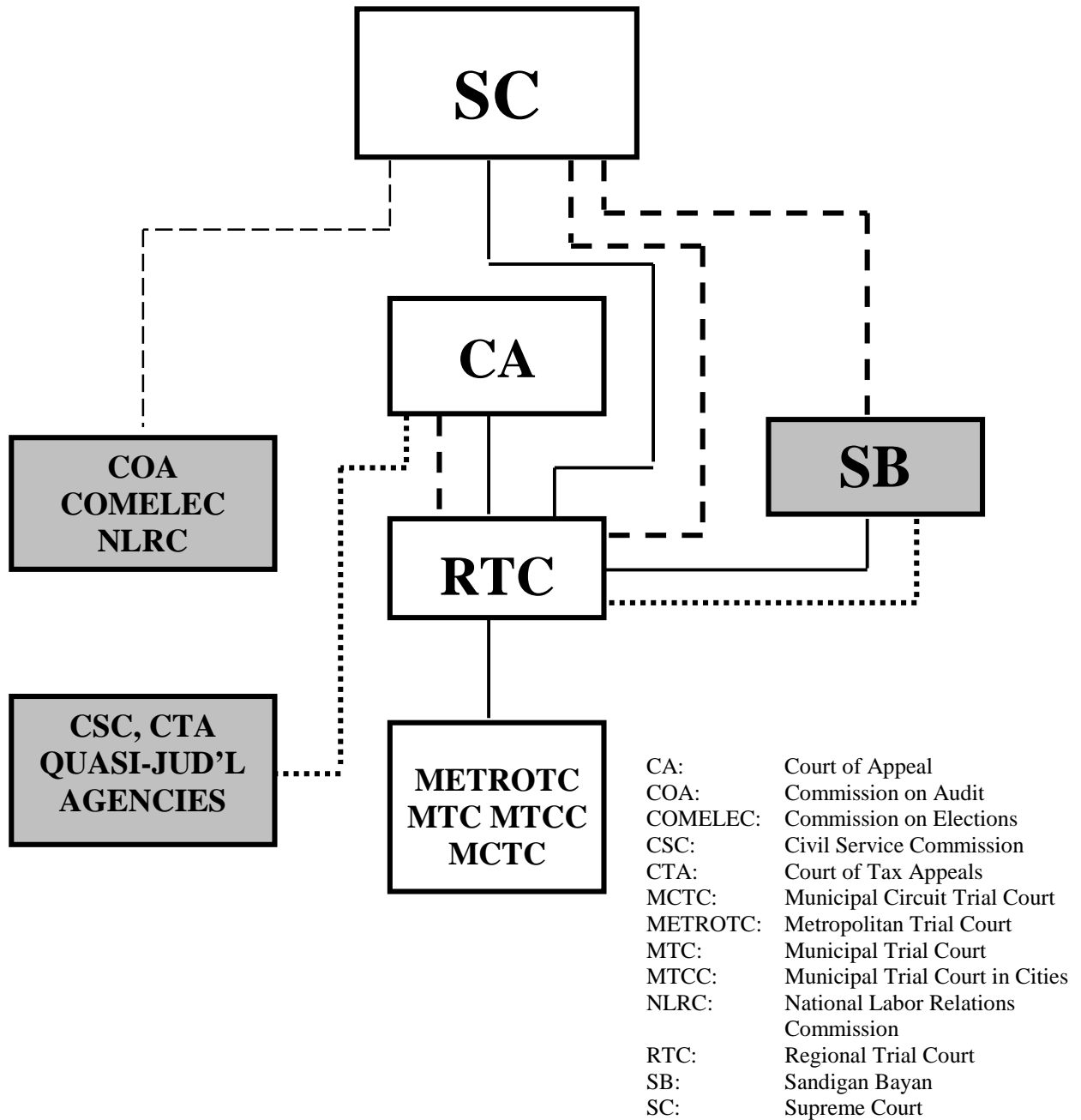

Legend:

- Petition for *certiorari* (Rule 65)
- Petition for Review
- - - Petition for review on *certiorari* (Rules 45, 122)
- Ordinary appeal (Rules 40, 41, 122); N.B. From the RTC to SC, when *reclusion perpetua* or life imprisonment is imposed or for automatic review of death penalty.

List of Researchers

Concepcion L. Jardeleza

- Admitted to the Philippine Bar in May 1976
- University of the Philippines, College of Law, Bachelor of Laws, 1975
- University of the Philippines, College of Arts and Sciences, Bachelor of Arts Major in Political Science, 1971

Work Experience

- Law Education Specialist , University of the Philippines Law Center, Institute of Judicial Administration, 1995-present
- Senior Lecturer, Legal Profession, University of the Philippines College of Law, SY 2000-present
- Lecturer, Problem Areas in Legal Ethics, Far Eastern University Institute of Law, SY 1999-present
- Researcher, Committee on Judicial Reform Research Group, Supreme Court of the Philippines, 1997-present
- Lecturer, Legal Ethics and Practical Exercises, San Sebastian College Institute of Law, SY 1999-2000
- Resource Person, Committee on Responsibility, Discipline and Disbarment of the Integrated Bar of the Philippines that Drafted the Code of Professional Responsibility (Justice Irene R. Cortes, Chairman)
- Private Practice, Jardeleza Law Office

Federico Cabansag Roxas II

- Admitted to the Philippine Bar in May 1998
- University of the Philippines, College of Law, Bachelor of Laws, April 1997
- University of the Philippines, College of Arts and Letters, Cum Laude, Bachelor of Arts in Philippine Studies, April 1993
- Cavite Institute, 5th Honorable Mention, Silang, Cavite, March 1988
- Philippine Christian University, Cavite, March 1984

Work Experience

- Partner, Roxas & Roxas Law Offices, since January 2001
- Junior Associate, Escudero Marasigan Sta. Ana Vallente & E.H. Villareal Law Offices (EMSAVVIL LAW), May 1999-December 2000
- Junior Associate, Angara Abello Concepcion Regala & Cruz Law Offices (ACCRA LAW), October 1997-May 1999
- Graduate Assistant, Institute of International Legal Studies, U.P. Law Center, University of the Philippines, Diliman, Quezon City (January to June 1996)
- Instructor, University of Sto. Tomas, College of Nursing, 1st Semester (1993-1994)
- Research Associate, Department of Filipino and Philippine Literature, College of Arts and Letters, University of the Philippines, Diliman, Quezon City (1991-1992)

Clarisa V. Kuong

- Admitted to the Philippine Bar in May 1997 with an average of 81.75%
- Bachelor of Laws, University of the Philippines, Diliman, College of Law, 1991-1995
- Bachelor of Arts in Philosophy, University of the Philippines, Diliman, College of Social Sciences and Philosophy, 1987-1990

Work Experience

- Prosecution Attorney, Department of Justice, Padre Faura, Manila, September 1999-present
- Member, Task Force on Passport Irregularities, Department of Justice

- Designated, Special Team of Prosecutors as Acting Board of Canvassers for the 15 April 2000 Recall Election in Pasay City
- Facilitator, Training on Republic Act 7610 and related laws for the National Capital Region, Multi-Purpose Building, Department of Justice, Padre Faura, Manila, 29 May to 1 June 2000
- Facilitator, Training on Republic Act 7610 and related laws for Region III, Oasis Hotel, Clarkville Compound, Clark Perimeter Road, Balibago, Angeles City, July 11 to 14, 2000
- Lecturer, "Media Guideline on the Reporting and Coverage of Cases Involving Children," Training on Republic Act 7610 and Related Laws, For Region III, Oasis Hotel, Clarkville Compound, Clark Perimeter Road, Balibago, Angeles City, July 13, 2000
- Associate Lawyer, Sobrevinas Diaz Hayudini & Bodegon Law Offices, April 1998-August 1999
- Associate Lawyer, Ongkiko Kalaw Manhit Acorda Law Offices, February 1997-March 1998
- Marketing Assistant, Blimson Hardware, March-December 1995
- Paralegal, Office of Legal Aid, University of the Philippines College of Law, June 1994-March 1995
- Graduate Assistant, Office of the Registrar, University of the Philippines, October 1994-February 1995

Venus B. Magay

- Admitted to the Philippine Bar on 6 May 1998
- Bachelor of Laws, University of the Philippines, Diliman, College of Law, 1997
- Bachelor of Arts in Philosophy, University of the Philippines, Diliman, College of Social Sciences and Philosophy, 1985

Work Experience

- Court Attorney, Office of Justice Martin S. Villarama, Jr., Court of Appeals, 16 June 1998 to present
- Legislative Researcher, Chief Political Affairs Officer, Office of Rep. Alfredo E. Abueg, Jr. (2nd District, Palawan, Philippines), House of Representatives, IBP Road, Quezon City, July 1992 to June 16, 1998
- Executive Secretary to the Executive Director, Information Assistant/Writer, Palawan Integrated Area Development Project Office (PIADPO), Barangay Irawan, Puerto Princesa, Palawan, Philippines, July 1989 to May 1991
- Executive Assistant and Secretary to the Board of Directors, Puerto Princesa City Water District, June 1987 to December 1988
- Part-time Instructor, College Department, Holy Trinity College, Puerto Princesa, Palawan, July 1987 to March 1991

Gerrone Yu Apolona

- Admitted to the Philippine Bar in May 1998
- Bachelor of Laws, University of the Philippines College of Law, April 1997
- Bachelor of Arts in Political Science, University of the Philippines College of Social Sciences and Philosophy (*cum laude*), April 1992

Work Experience

- Human Resources and Administration Manager/Lawyer, Brand-Rex, Inc., Subic Bay, Philippines, since June 1999
- Associate, Angara Abello Concepcion Regala and Cruz Law Offices, October 1997 to April 1999
- Research Assistant, U.P. Law Center, Institute of Judicial Administration, June 1996 to May 1997
- Graduate Assistant, Office of Prof. Myrna S. Feliciano, January to May 1996
- Researcher, Joint Project of the Department of Agrarian Reform (DAR) and the U.P. Institute of Judicial Administration (UP-IJA), entitled, "Study of the Capability of the Administrative and Quasi-Judicial Machinery in the Speedy Disposition of Agrarian Cases," October 1994 to April 1995
- Apprentice and Administrative Assistant, Office of Atty. Pedro N. Tanchuling, September 1993 to July 1994
- Research and Publications Officer, Labor Education and Research Network (LEARN), Inc., 1992

Dick B. Perez

- Passed the Bar Examination given in September 1997
- Admitted to the Philippine Bar on June 1, 1987
- Bachelor of Laws, University of the Philippines College of Law, Diliman, Quezon City, 1986
- Bachelor of Arts in Social Science (Economics), University of the Philippines, Diliman, Quezon City, 1981

Work Experience

- Partner, Penaflor and Perez Law Offices (now Perez Benavides & Tapanan), Quezon City, Metro Manila, Philippines, 1993-present
- Associate Lawyer/Junior Partner, Gozon Fernandez Defensor & Parel Law Offices, 1988-1990
- Confidential Attorney, Court of Appeals, Office of Justice Jose R. Melo, 1987-1988
- Senior Executive Assistant, Ministry of Transportation and Communications, 1985
- Consultant, Institute of Labor and Manpower Services (ILMAS), Ministry of Labor, 1983.

Conrado A. Flores, Jr.

- Admitted to the Philippine Bar in 1999
- Bachelor of Laws, University of the Philippines College of Law, Diliman, Quezon City, 1999
- Bachelor of Arts, Major in Philosophy, University of the Philippines, Diliman, Quezon City, 1992

Work Experience

- Junior Associate, Abello Concepcion Regala & Cruz Law Offices, 1999 to present
- Legal Assistant, Racela Law Office, April 1997-April 1998
- Research Assistant/Graduate Assistant, U.P. Law Center Institute of Judicial Administration, October 1998-October 1999
- Legal Assistant, Law Firm of R.V. Domingo, May 1996-1997