

This item is held in Loughborough University's Institutional Repository (<https://dspace.lboro.ac.uk/>) and was harvested from the British Library's EThOS service (<http://www.ethos.bl.uk/>). It is made available under the following Creative Commons Licence conditions.



creative
commons
C O M M O N S D E E D

Attribution-NonCommercial-NoDerivs 2.5

You are free:

- to copy, distribute, display, and perform the work

Under the following conditions:

 **BY:** **Attribution.** You must attribute the work in the manner specified by the author or licensor.

 **Noncommercial.** You may not use this work for commercial purposes.

 **No Derivative Works.** You may not alter, transform, or build upon this work.

- For any reuse or distribution, you must make clear to others the license terms of this work.
- Any of these conditions can be waived if you get permission from the copyright holder.

Your fair use and other rights are in no way affected by the above.

This is a human-readable summary of the [Legal Code \(the full license\)](#).

[Disclaimer](#) 

For the full text of this licence, please go to:
<http://creativecommons.org/licenses/by-nc-nd/2.5/>

DEVELOPMENT AND APPLICATIONS OF
ION-SELECTIVE ELECTRODES

by

AGHA SANAULLAH PATHAN, B.Sc.(Hons), M.Sc.(SIND),
M.Sc.(Loughborough), A.R.I.C.

A thesis submitted in fulfilment of the requirements
for the award of Doctor of Philosophy of the
Loughborough University of Technology

Supervisors: DR. A.G. FOGG
DR. D. THORBURN BURNS

Department of Chemistry; Loughborough University
of Technology

September

1974

©

AGHA SANAULLAH PATHAN,

1974

ACKNOWLEDGMENT

I wish to thank my supervisors Dr. A.G. Fogg and Dr. D.Thorburn Burns for their stimulating guidance, invaluable suggestions and encouragement throughout my studies. Also thanks are due to Professor R.F. Phillips for his interest.

I wish to thank Professor G.M. Shah, ex-Vice Chancellor of the University of Sind (Pakistan), for granting me leave of absence and financial assistance. I am highly indebted to Al-Haj M.Y. Agha, C.S.P. (Retired), whose invaluable help and untold kindness have always remained of great importance to me.

Thanks are due to the members of technical staff who have always been very co-operative and helpful; to Mr. M. Duzinkewycz for carrying out some of the experiment work on the zinc electrode under my guidance; also to the Harborough Rubber Company for their gift of natural rubber sheetings.

I acknowledge with great thanks the useful discussion of Mr. A.E. Bottom and Dr. A.M.G. Macdonald.

I feel it essential to mention the moral support and encouragement which I have received from my family at the times when I really needed it; especially from my brother Mr. A.A. Pathan who at some difficulty to himself has given me financial support on different occasions without which my stay in this country would have been very difficult.

Finally, I thank all my colleagues for the very pleasant and unforgettable time that I have had with them at Loughborough.

D E D I C A T I O N

This thesis is dedicated most respectfully to my parents and with love and sincerity to my wife.

It was a bitter irony of fate that my father, whose faith in me, moral and financial support, and patience has been unwavering over the years while I struggled on, should leave us when I was just to accomplish one of his most cherished desires.

C O N T E N T S

	<u>Page No.</u>
<u>SYNOPSIS</u>	1
<u>INTRODUCTION</u>	3
<u>ION-SELECTIVE ELECTRODES:</u>	
Glass electrodes	9
Homogeneous solid-state electrodes	29
Heterogeneous solid-state electrodes	37
Selectrodes	44
Liquid ion-exchanger electrodes	47
Gas-sensing electrodes	59
<u>BASIS OF THE PRESENT WORK.</u>	70
<u>GENERAL DESCRIPTION OF ELECTRODE PREPARATION AND APPARATUS USED.</u>	72
<u>SURFACTANT ION-SELECTIVE ELECTRODE.</u>	
Introduction.	78
Experimental:	
Preparation of hexadecyltrimethylammonium- dodecylsulphate.	80
Evaluation of the electrode response	81
Applications of electrodes in potentiometric titrations.	85
Discussion.	96
<u>POTASSIUM ION-SELECTIVE ELECTRODE.</u>	
Introduction.	101
Experimental:	
Preparation of the membranes.	102
Evaluation of the electrodes.	102
Effect of pH on the electrodes potential.	108
Effect of temperature changes.	108
Calculations of selectivity constants.	110
Discussion.	112
<u>THE POTENTIALITIES OF BASIC DYE SALTS FOR USE IN ION-SELECTIVE ELECTRODES.</u>	115

ZINC ION-SELECTIVE ELECTRODE

Introduction 119

Experimental:

Preparation of Brilliant Green tetrathiocyanatozincate(II). 119

Preparation of the electrodes. 120

Evaluation of performance of electrodes. 120

Study of pH effects on electrode potential. 125

Discussion 127

PERCHLORATE ION-SELECTIVE ELECTRODE

Introduction 128

Experimental:

Preparation of Brilliant Green perchlorate. 128

Choice of the Rubber in electrode preparation. 129

Evaluation of the Electrode. 130

Effect of pH on electrode response. 134

Study of the effect of temperature on potential. 135

Application of Perchlorate ion-selective electrode in potentiometric titrations. 137

Discussion. 139

TETRAFLUOROBORATE ION-SELECTIVE ELECTRODE

Introduction 143

Experimental:

Preparation of Brilliant Green tetrafluoroborate. 143

Preparation of the Electrode. 143

Evaluation of the performance of the electrode. 144

Study of the effect of pH. 147

Effect of temperature on electrode response. 148

Discussion 149

APPLICATION OF A SULPHIDE ION SELECTIVE ELECTRODE IN STUDY OF THE REACTION BETWEEN SULPHIDE AND NITRO-PRUSSIDE.

Introduction. 154

Experimental:

Preparation of solutions.	156
Apparatus assembly.	157
Standardisation of Sodium sulphide solution.	157
Potentiometric titration of sodium sulphide with sodium nitroprusside.	158
Colorimetric study of the nitroprusside- sulphide reaction.	159
A recommended colorimetric procedure for sulphide determination.	165

Discussion.	166
-------------	-----

<u>GENERAL DISCUSSION AND SUGGESTIONS FOR FURTHER WORK</u>	170
--	-----

<u>APPENDIX I</u>	176
-------------------	-----

<u>BIBLIOGRAPHY</u>	179
---------------------	-----

SYNOPSIS

The present work is mainly concerned with the development of new electrodes. Heterogeneous solid state electrodes based on silicone rubber and P.V.C. membranes which are responsive to surfactant and potassium ions, have been developed. A surfactant electrode, which gives good Nernstian response to cationic detergents over a range of 10^{-3} to 10^{-5} M concentrations, and which is stable for more than two weeks, has also been employed in potentiometric titrations of cationic detergents with anionic detergent as well as with some other salts such as sodium tetraphenylboron, ammonium reinekate, potassium hexacyanoferrate(III) and potassium dichromate. The response of a potassium ion-selective electrode based on potassium zinc ferrocyanide as the active material, is almost theoretical (i.e 59.0 mV per decade). Caesium, rubidium and ammonium interfere but the selectivity constant for potassium over sodium is better than for glass electrodes. The potential-activity slope is constant for over two months.

A new type of liquid state electrode assembly based on a natural rubber membrane and using a graphite rod as internal reference electrode, has been developed for use with organic salts which are soluble in organic solvent. Electrodes have been developed for determination of zinc(II), perchlorate and tetrafluoroborate ions, using basic dye salts containing those anions. In general, natural rubber sheeting is treated with a water immiscible organic solvent containing the salt; swollen sheeting is used as the membrane. These electrodes respond in a Nernstian manner, giving a potential-concentration slopes of 29.5, 57.5 and 58.5 mV for zinc(II), perchlorate and tetrafluoroborate electrodes respectively. The slope is stable for a reasonable length of time, e.g. potential-concentration slope is decreased by

0.5 mV after about three to five weeks, depending on the type of electrode. In the preparation of these electrodes, the choice of solvent and the kind of natural rubber has been carefully selected, as these factors influence the operation of the membrane. Effects of solution pH and the temperature variations on response of the electrodes, have also been studied.

Further work also has been done on studying the Gmelin reaction (reaction of nitroprusside and sulphide ions) with a sulphide ion-selective electrode. This reaction involves a study of the reaction between nitroprusside and sulphide ions, where nitrosyl group is modified to pentacyanothionitroferrate(II) imparting a purple colour to the solution. For determination of sulphide and nitroprusside by potentiometric titration optimum conditions have been developed. Also a colorimetric procedure for sulphide determination is recommended.

INTRODUCTION

For the last four decades it has been known that a glass membrane electrode having a particular composition may be made part of a potential measuring cell which will respond to changes in the activity of hydrogen ions. As a result of a detailed study of the cation sensitivity of the aluminosilicate glasses, Eisenman et al⁽¹⁾ showed that the relative sensitivities to different ions vary systematically with the glass composition. Thus an incentive was provided to think of new materials and the preparation of new electrodes. This led to the development of glass electrodes sensitive to cations other than hydrogen ions; though Lengyel and Bulman⁽²⁾ had predicted long ago that the preparation of glass electrodes sensitive to metal ions should be possible; a Nernstian response to Na^+ could be obtained upon the introduction of Al_2O_3 or B_2O_3 (or both) into a glass.

With the development of electrode technology efforts were made by different workers to introduce new types of electrodes which were easy to prepare and use and which also were more selective and durable from the chemical and mechanical points of view respectively. This led to the invention of new types of electrodes based on different membranes. These membranes take the form of ^{either} ion-conductive crystals or inert hydrophobic membranes, the latter being either impregnated with solid ion-sensor or saturated with a solution of a particular active material dissolved in a non-aqueous phase. Such membranes by virtue of the ion-conductivity of the sensor present in them distinguish a particular ion in solution and respond to its activity. Electrodes with such properties are known as Ion-selective Electrodes.

Over the past 15 years a considerable number of such electrodes responsive to a wide range of different cations and anions have been developed. The construction of these electrodes is not restricted

to a particular material, shape, size or design. Various types of electrodes developed differ mainly in the particular membrane that is used, as each of the membrane has its own special properties.

The development of this new analytical tool has given an increasing importance to analytical potentiometry as the range of the technique has been extended greatly and has created a great deal of interest both theoretical and practical. The ion-selective electrode forms an electrochemical half cell responding to a particular ion in the external solution under test. Ideally electrodes give a Nernstian potential-activity slope within their working range. The potentials of the electrodes change with change in ionic activities of the species to which they are selective. None of the electrodes developed are entirely specific to a particular ion but will respond to certain other ions which will act as interferants.

Ion-selective electrodes give direct information about the composition of solutions and this has led to an interest in measuring techniques as well as in associated equipment to convert the output potential signals directly into activities or concentrations. The increasing use of these ion-selective electrodes is due to certain advantages which they have over other analytical techniques. For example, the presence of insoluble impurities or colour of the solutions do not have any effect on electrode response; also except under special circumstances the solutions do not need any pre-treatment and can be used directly for potentiometric measurements.

Ion-selective electrodes respond directly to concentrations or activities over a wide range and usually respond very rapidly. The response times reported in the literature vary but often are under one minute. According to Ray⁽³⁾, steady potential is generally achieved in 15 sec. to 1 minute, whereas Moody and Thomas⁽⁴⁾ have

reported the response time of various electrodes within a few seconds. A patent⁽⁵⁾ on potassium liquid state electrode indicates such time less than one second; also in the recent paper of Fleet, Ryan and Brand⁽⁶⁾ response time reported varies from 10 m.sec to several minutes depending on the type of ion-selective membrane. This real time response allows the continuous monitoring of composition changes of flowing and changing solutions. The electrodes have quite long lifetimes and are relatively not very expensive; also they can be used with reproducibility and great accuracy. The electrodes are convenient to use and for this reason find extensive applications; also being portable they are conveniently used in field studies.

The generally accepted classification of membrane electrodes is according to the physical state of the membranes used. The electrodes are classified into four main types as follows:-

1. Glass Electrodes
2. Solid-state Electrodes
 - i. Homogenous solid-state (or crystal) membrane electrode
 - ii. Heterogeneous solid-state membrane electrodes.
3. Liquid ion exchange membrane Electrodes
4. Gaseous membrane Electrodes

The construction of these electrodes will be dealt with in detail in later sections. In general, ion-selective electrodes with glass membranes are prepared by varying the ratio of lithium or sodium and aluminium oxide in the silica matrix.

The crystal membrane and heterogenous membrane electrodes are placed under the same class of solid-state because although they differ from each other physically, nevertheless they respond in a similar manner. In general, solid-state electrodes are based on water insoluble salts and complexes, which form ionically conducting membranes. These

membranes take the form of either a single crystal such as lanthanum fluoride, a polycrystalline material such as silver sulphide, or mixtures of silver sulphide and silver halides or silver sulphide and metal sulphides. The polycrystalline material may be compressed to form a disc (homogeneous) or may be dispersed in a polymeric material (heterogeneous). This latter type was made by Pungor⁽⁷⁾ using silicone rubber and more recently by Moody, Oke and Thomas⁽⁸⁾ using polyvinylchloride. Apart from these forms various materials such as paraffin wax, collodion and various plastics have been used⁽⁹⁾.

In liquid ion-exchange membrane electrodes, the ion-exchanger is dissolved in a water immiscible solvent held in a reservoir within the electrode body. The ion-exchanger is absorbed into a thin porous hydrophobic membrane which acts as the electrode. As a result of recent developments, direct measurements of acidic or basic gases can also be made easily by using a hydrogen ion-sensitive electrode, which is separated from the test solution by an electrolyte solution and a gas permeable membrane. The gas permeates the membrane changes the pH of the electrolyte solution and gives a response.

The species to which electrodes have been made to respond range from inorganic ions to organic ions and molecules (particularly those of biochemical significance). Miniaturized electrodes are meeting specific demands in biochemical fields. These are designed according to requirements by varying the construction of the electrode. Such electrodes are required for in vivo and in vitro measurements, where the volume of the solutions used is limited. Electrodes have been modified to be responsive, for example to enzymes, in which generally the responsive membranes is covered with a reactive layer.

Ion-selective electrodes behave electro-chemically in the same manner as hydrogen ion-selective (pH) electrodes, which exhibit poten-

tials according to Nernstian equations,.

$$E = E^{\circ} + 2.303 \frac{RT}{ZF} \log a_{H^+} \quad (1)$$

where E = potential developed by electrode system.

E° = a constant potential, value of which depends on the choice of reference electrode.

R = Gas Constant ($8.3143 \text{ JK}^{-1} \text{ mol}^{-1}$).

T = absolute temperature.

F = Faraday constant (96487 C mol^{-1}).

and Z = charge on the ion being measured.

If the same reference electrode is used throughout, the value of E° remains fixed. The term $2.303 RT/F$ has a fixed value at a given temperature (59.16 mV at 25°C); therefore the value of potential E depends only on $\log a_{H^+}$. To generalise the equation for any cation or anion, the Nernstian potential-activity response can be given respectively as,

$$E = E^{\circ} + 2.303 \frac{RT}{ZF} \log a_{x^+}$$

$$\text{or } E = E^{\circ} - 2.303 \frac{RT}{ZF} \log a_{x^-}$$

As in practice, no electrode is specific for a particular ion, therefore within certain limits other ions in the solution contribute to the membrane potential. In such cases the Nernstian equation will be modified as

$$E_{\text{cell}} = E^{\circ} + 2.303 \frac{RT}{ZF} \log \left[a_x z^{\pm} + K_{XY} (a_Y y^{\pm})^{z/y} \right] \quad (2)$$

where K_{xy} is the selectivity constant of the interfering ion Y relative to primary ion X for the given electrode. It is observed that the selectivity of the membrane changes with the activity of the primary ion in the solution. If the electrode is giving a perfect Nernstian response for a primary ion the value of K_{xy} is very small. Knowledge of the value K is of great importance when ion-selective electrodes

are being used in mixed solutions because it provides an indication of the concentration of an interfering ion that can be tolerated relative to the concentration of the primary ion.

Due to the rapid development in the field of ion-selective electrodes, a vast number of papers and reviews have appeared in the literature in a relatively short time. Several reviews both long and short on the general subject have been published ⁽¹⁰⁻²⁷⁾, of which the most comprehensive are those of Buck ^(23, 24), Moody and Thomas ⁽²⁵⁾, Koryta ⁽²⁶⁾ and Tenygl ⁽²⁷⁾. A recent critical review of Covington ⁽²⁸⁾ traces out the history of the development of ion-selective electrodes. Apart from this, some reviews on individual types, covering different aspects of glass membrane ⁽²⁹⁻³¹⁾, solid-state ^(32,33) (crystal membrane) and heterogeneous membrane ⁽³⁴⁻³⁷⁾ have been published by various workers. The comparison of liquid and solid-state ion-selective electrodes is briefly discussed by Eisenman ⁽³⁸⁾. Also two textbooks, "Ion-selective electrodes", an N.B.S. publication 314 edited by R.A. Durst ⁽³⁹⁾, and "Selective Ion-sensitive electrodes" by Moody and Thomas ⁽⁴⁾, are the main texts on the subject.

Some papers are concerned principally with specific applications of ion-selective electrodes in various fields. Apart from routine potentiometric measurements, the ion-selective electrodes have a wide range of applications in various fields, for example water and pollution monitoring ⁽⁴⁰⁻⁴⁵⁾, industrial processes ^(46, 47), electroplating ⁽⁴⁸⁾, clinical analysis ^(49, 50), fertilizer analysis ⁽⁵¹⁾, and in biological and pharmaceutical applications ^(52, 53).

GLASS ELECTRODES

Glass electrodes are the oldest of the ion-selective electrodes. Cremer⁽⁵⁴⁾ was the first who observed that a potential difference developed at 0.02 mm thick glass membrane placed between two aqueous solutions, was sensitive to changes in acidity. This was further investigated by Haber and Klemensiewicz⁽⁵⁵⁾, who concluded that the potential difference between the solutions changes with change in hydrogen ion concentration; similar to the change in electrode potential of a hydrogen electrode in solution of varying pH. Glass electrodes were commercially prepared from a suitable type of soda lime glass discovered by MacInnes and Dole⁽⁵⁶⁾. Later, lithia-lime-silicate glass membranes were introduced⁽³¹⁾, which had wider error-free pH response and increased durability. But these glasses possessed high electrical resistance. It was not until the early 1950's that lithia-based glasses became generally available. Present day pH glass compositions are all lithia-based; the durability and pH response have been improved by addition of, for example, rare earth and heavy alkaline metal oxides. Resistance has also been reduced by replacing part of silica with, for example, Uranium Oxide.

With the development of glass technology improved glasses were introduced, which resulted in the production of glass membranes selective to alkalimetal cations. This was the major contribution of Eisenman⁽¹⁾ and his co-workers, who made a systematic study of simple glasses containing Na_2O , Al_2O_3 and SiO_2 and reported that the sensitivity for the alkali-metal cations relative to one another and to hydrogen ion was a function of glass composition.

Glass electrodes can be considered to be a special kind of heterogeneous membrane electrode, as the active groups are embedded and dispersed in the silicate structure. Glass electrodes are usually similar in their construction except for the marked difference in the compositions of the glass which is responsible for sensitivity and selectivity. The electrodes

consist of a high resistance non-ion sensitive glass tube to which thin membranes of selective ion-sensitive glass is sealed either directly or through graded glass connections. The selectivity towards different cations varies according to the type of the glass used. Glasses are chosen to give as selective a response as possible to one particular ion. It is possible that the degree of selectivity may vary between different electrodes of the same composition owing to differences occurring during manufacture. Also asymmetry potential is due to chemical differences between the two surfaces. This could arise, for example, from the greater vaporization of Na_2O from the outer surface during exposure to the flame⁽⁵⁷⁾. For proper functioning of an electrode the membrane thickness is critical because above a certain thickness potential variations occurs and even the best shielding available may not allow accurate measurements to be made.

The electrode is filled with an electrolyte solution which acts as a reference medium. A metallic, electrolytically-conducting wire-electrode connected to the main lead is immersed in the solution to provide the required electrical connection, a section of the electrode is shown in figure 1. At very high temperatures the internal electrolyte will boil thus disrupting the operability of the electrode. Moreover, in the case of micro-electrodes used in biological and medical fields difficulty may be experienced in placing an aqueous reference electrolyte into the minute interior of a capillary tube or in the use of hydrated gels which would decompose and vapourise at the temperature at which the electrode is being used. To overcome such difficulties a solid electrolyte salt connecting one surface of the membrane with the usual metallic, electrolytically conducting electrode, is used⁽⁵⁸⁾. The solid electrolyte contains a mobile cation having a diffusion coefficient of the same order as that of the mobile ion in the glass. Otherwise a cation with an unequal mobility will generally create an undesirable polaris

able region between the solid material and the glass. Also as the electrolyte mass is anhydrous, no surface hydration takes place upon the interior of the membrane as is the case when the glass is in contact with an aqueous reference electrolyte. This also avoids the problem of short circuiting when the two hydrated layers which form continuously on either side of the membrane come in contact with each other after the electrode has been used extensively.

The conventional glass membrane is in the form of a thin walled glass bulb, but now thin and needle like electrodes are also available which are used for some biological and clinical studies⁽⁵⁹⁾. Moreover, a solid state glass electrode⁽⁶⁰⁾ can also be prepared by first coating an electro-chemically active metal preferably copper, by a glass mixed with a salt being a halide of the same metal. This is followed by a second coating of an ion-selective glass which forms the ion-sensitive membrane of the electrode. The development of glass electrodes selective to cations other than hydrogen ions have led to the direct measurements of monovalent and divalent cations. Apart from this glass electrodes can also be modified by placing a layer of trapped enzymes over the membrane surface (Figure 2). The idea was first introduced by Guilbault and Montalvo⁽⁶¹⁾. Later the design was further modified⁽⁶²⁾ by holding the enzyme gel on electrode surface by means of a cellophane film. Electrodes have been developed for example, for the determination of Urea⁽⁶³⁻⁶⁶⁾, amino acids⁽⁶⁷⁻⁷⁰⁾ and for assay of serum cholinesterase⁽⁷¹⁾.

Glasses used for membranes contain at least three constituents SiO_2 , R_2O and MO (or M_2O_3), where R is an alkaline metal and M is a bivalent or trivalent metal preferably one of the rare earth group.

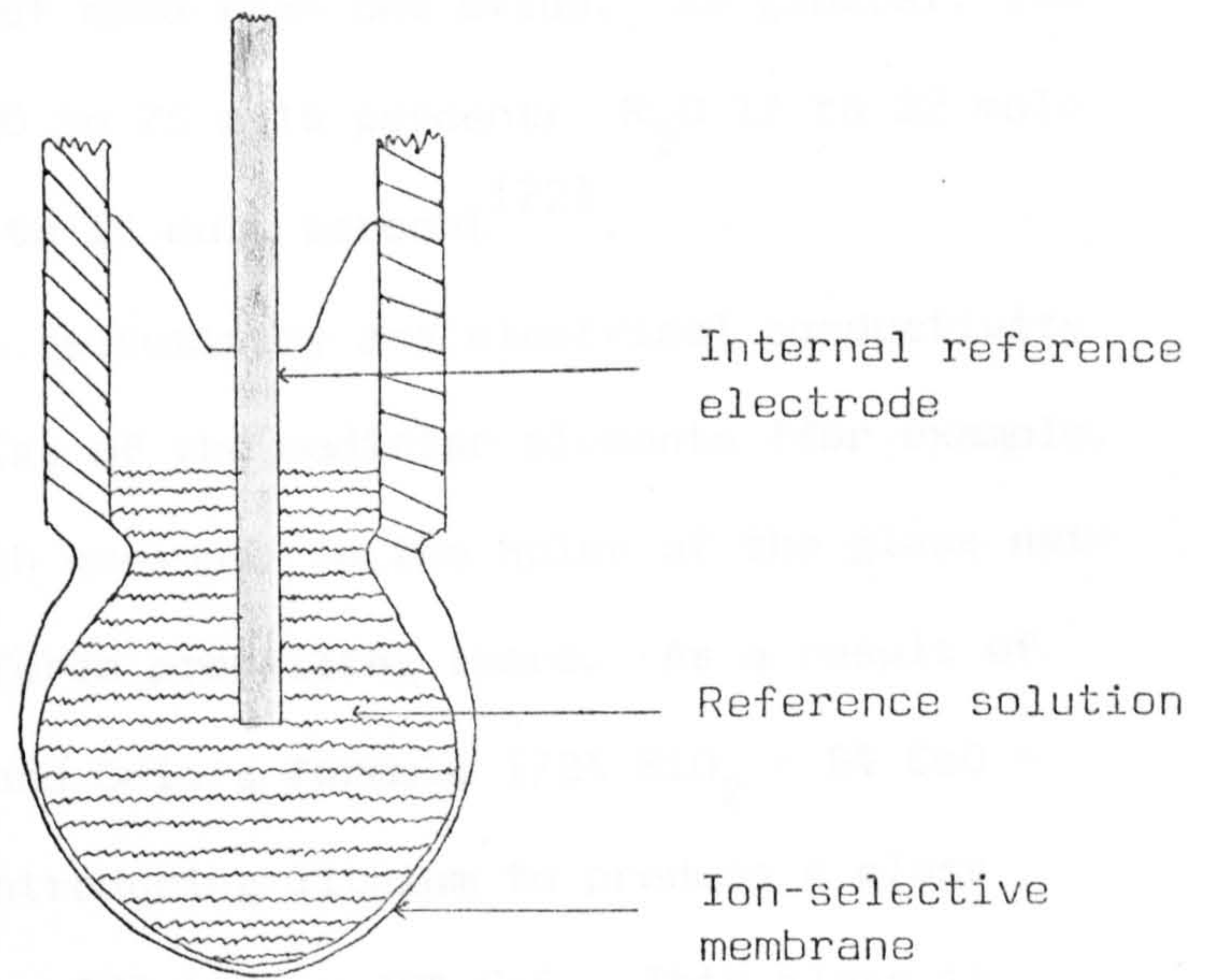

Glass electrode

Figure (1)

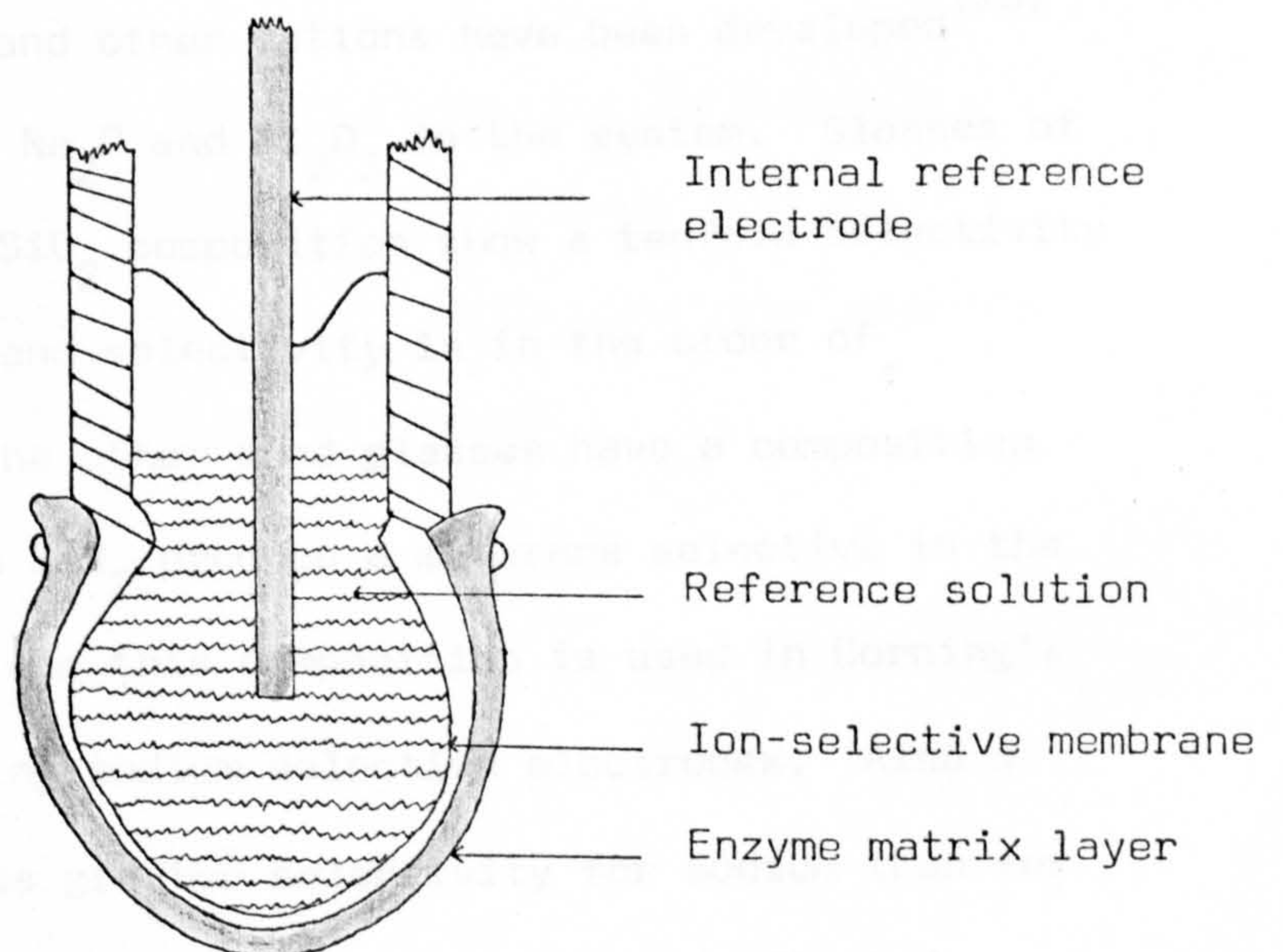

Enzyme substrate electrode

Figure (2)

R_2O and MO may be a mixture of more than one oxide. In general, the composition range is SiO_2 60 to 75 mole percent; R_2O 17 to 32 mole percent; and MO (or M_2O_3) 3 to 16 mole percent⁽⁷²⁾.

In general, stability, selectivity and electrical conductivity depend on the ionic properties of the modifier elements (for example, the alkali and alkaline earth cations) in the holes of the glass network and the electrostatic force prevailing there. As a result of these conclusions MacInnes and Dole's formula (72% SiO_2 - 6% CaO - 22% Na_2O) was modified by introducing lithium to produce a glass having composition 72% SiO_2 - 18% Li_2O - 10% CaO . This glass is supposed to have a working pH range 1 to 13 and to have a reduced alkaline error. This latter is due to the fact that Li^+ has a co-ordination number of four. The strongly bonded lithium ions within the lattice show little tendency to exchange with other larger cations in the solution. By modifying the composition of the glass, the selectivity order as well as the degree of selectivity can be changed. As a result of this, glass electrodes possessing a usable response to sodium, potassium, silver and other cations have been developed⁽⁷³⁾ by changing the amounts of Na_2O and Al_2O_3 in the system. Glasses of 27% Na_2O - 5% Al_2O_3 - 68% SiO_2 composition show a tenfold selectivity for potassium over sodium and selectivity is in the order of, $H^+ > K^+ > Na^+ > Li^+$. On the other hand glasses have a composition 11% Na_2O - 18% Al_2O_3 - 71% SiO_2 produce a membrane selective in the order $H^+ > Na^+ > Li^+ > K^+$ and this composition is used in Corning's NAS 11 - 18 glass for making sodium selective electrodes. Also a glass with nearly 10^4 times greater selectivity for sodium than for potassium having composition of 69% SiO_2 - 11% Li_2O - 12% Al_2O_3 -

6% B_2O_3 and 2% Ga_2O_3 has been reported⁽⁷⁴⁾. Rechnitz⁽¹¹⁾ has made a survey of cation sensitive glass and has recommended the preferred compositions of lithium, sodium, potassium and silver ion-selective electrodes based on the data of Eisenman⁽⁷³⁾. (Table 1)

As regards the structure of glass membrane⁽⁴⁾, a pure silica glass, before the introduction of any basic oxide, has no electrode properties as there are no charge sites available for ion-exchange. In the model each silicon atom lies at the centre of tetra-hedron formed from four oxygen atoms, when an alkali metal oxide, e.g. Na_2O , is introduced

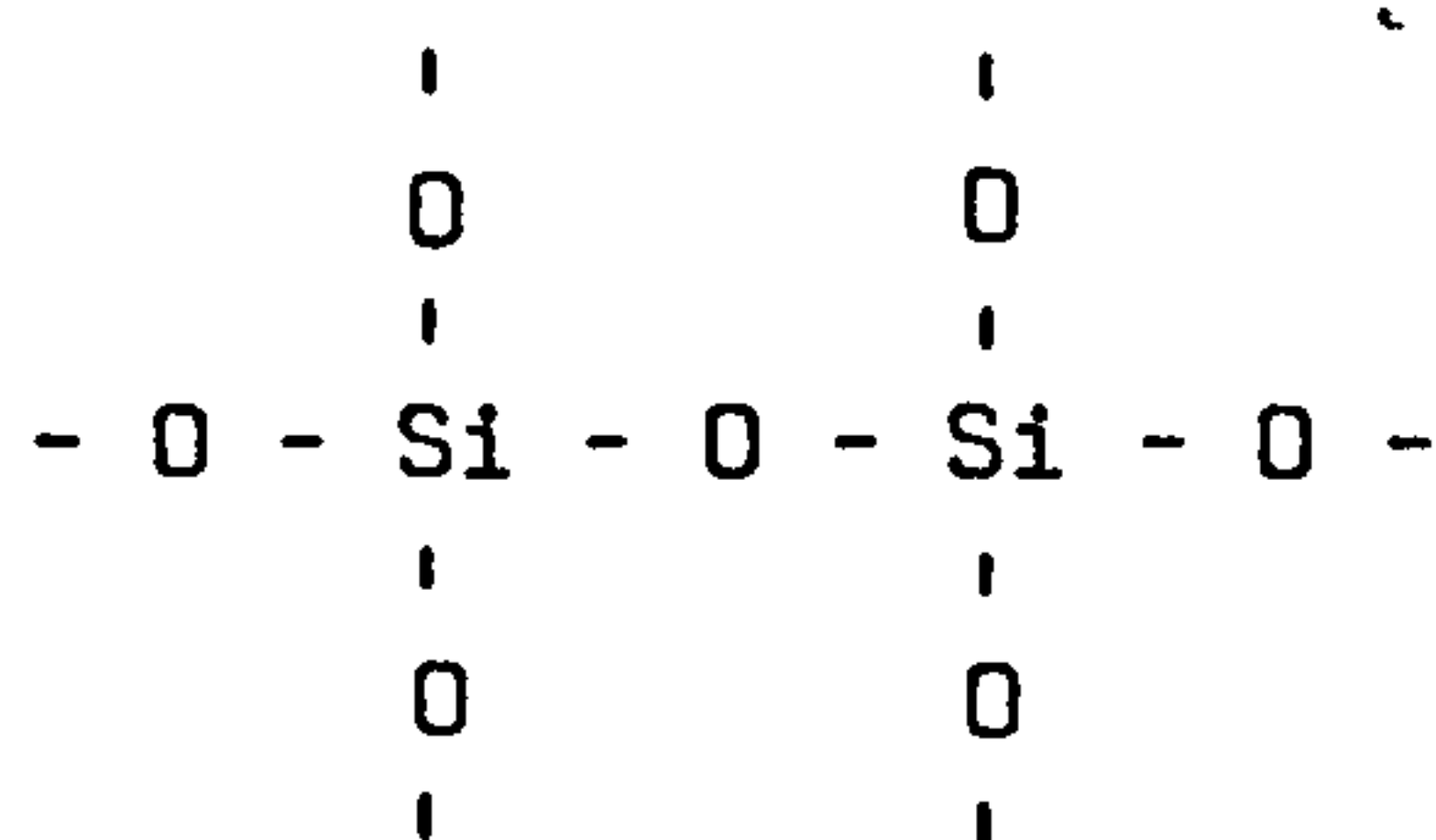

it disrupts the Si - O - Si linkages and gives rise to a singly charged oxygen co-ordinated to only one silicon atom, this gives a conducting glass with replaceable cations. Such structure show high specificity for hydrogen ions over other cations

TABLE I Recommended compositions of various glass electrodes (11)

Cation	Glass Composition (in % mol)	Approximate selectivity	Remarks
Li ⁺	15% Li ₂ O - 25% Al ₂ O ₃ - 60% SiO ₂	K _{Li⁺Na} + 0.35 K _{Li⁺K} > 10 ⁻³	Best for Li ⁺ in presence of H ⁺ and Na
Na ⁺	11% Na ₂ O - 18% Al ₂ O ₃ - 71% SiO ₂	K _{Na⁺K} 3.6 x 10 ⁻⁴ at pH 11.0 K _{Na⁺Na} 3.35 x 10 ⁻³ at pH 7.0	Nernstian response down to pNa ≈ 5
K ⁺	10.4% Li ₂ O - 22.6% Al ₂ O ₃ - 67% SiO ₂	K _{Na⁺K} 10 ⁻⁵	Highly Na ⁺ selective but very time dependent
Ag ⁺	27.0% Na ₂ O - 5.0% Al ₂ O ₃ - 68.0% SiO ₂	K _{K⁺Na} 0.05 - 0.1	Nernstian response to less than 10 ⁻⁴ M K
	28.8% Na ₂ O - 19.1% Al ₂ O ₃ - 52.1% SiO ₂	K _{Ag⁺H} 10 ⁻⁵	Highly sensitive and selective to Ag ⁺ but poor stability
	11% Na ₂ O - 18% Al ₂ O ₃ - 71% SiO ₂	K _{Ag⁺Na} 10 ⁻³	Less selective for Ag ⁺ but more reliable

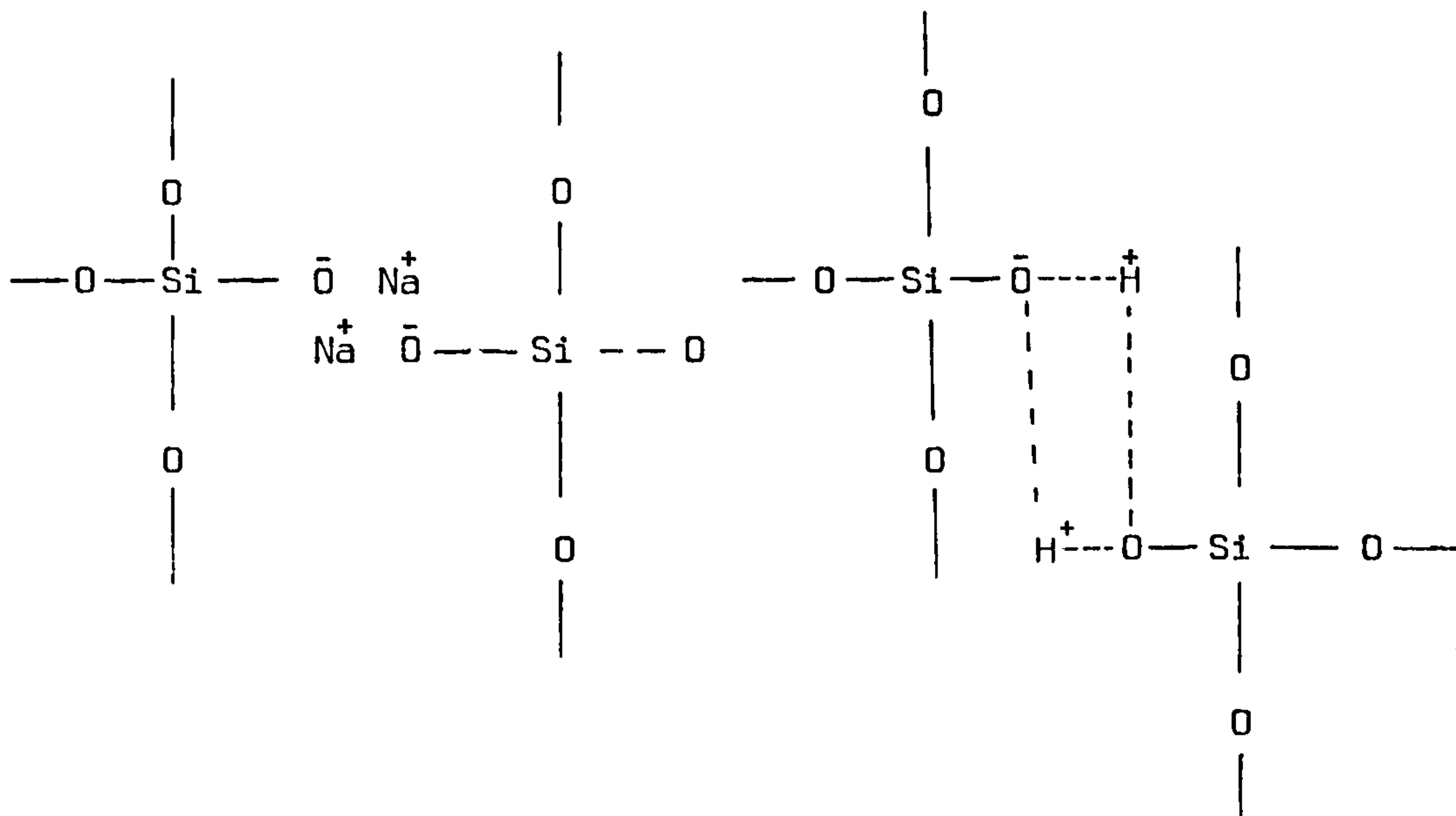

For the selectivity of cations over hydrogen ions, an element is introduced in the glass lattice in a co-ordination state higher than its oxidation state. For example, when Al^{3+} (as Al_2O_3) in oxidation state 3 is introduced into glass in a four fold co-ordination in place of silicon (IV), negatively charged tetrahedral groups are formed of the kind

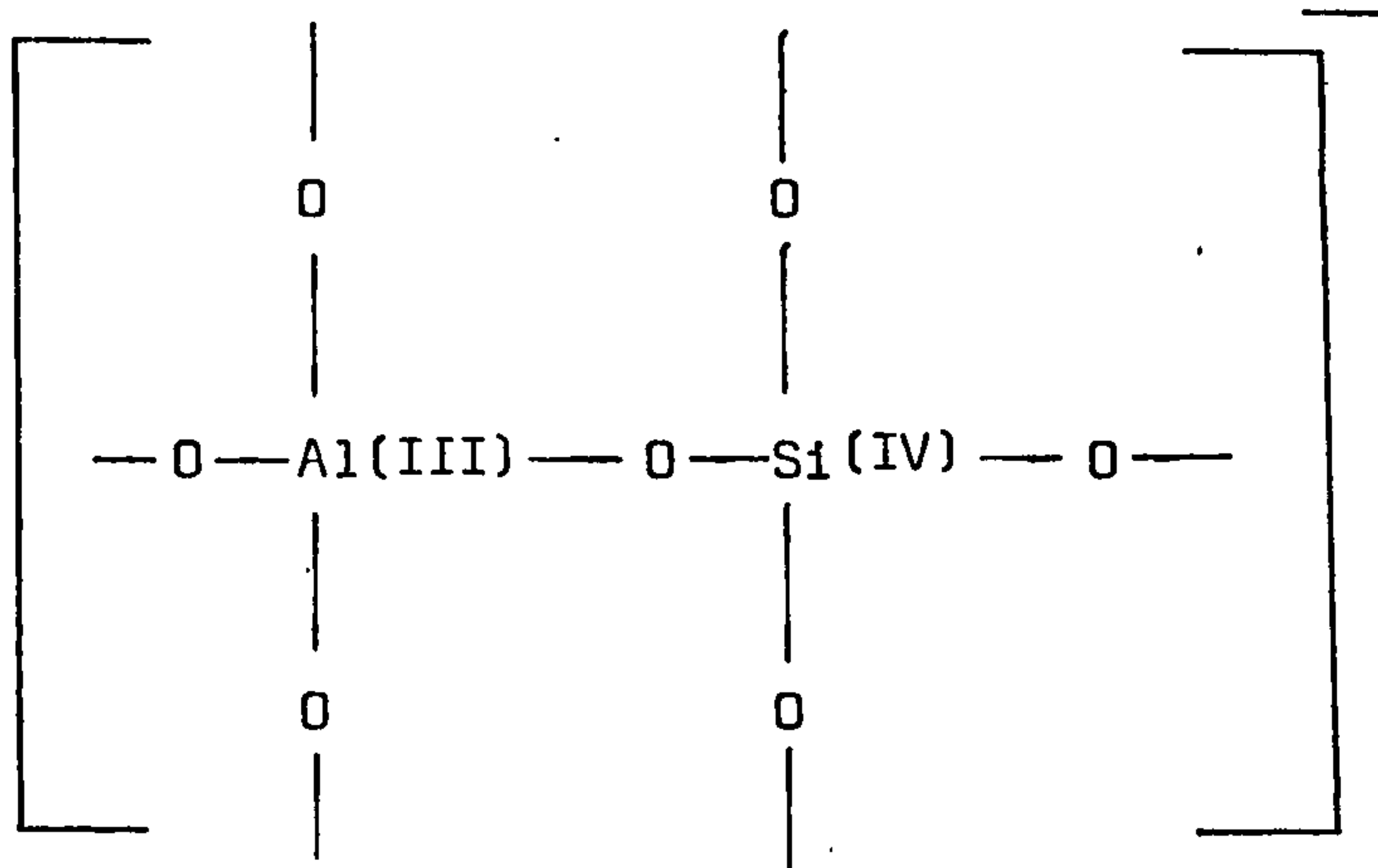

These in conjunction with Na_2O provide a site capable of cation exchange thus producing cation-responsive glasses. A low content of Al_2O_3 present in glass structure favours ions of larger radius and higher Al_2O_3 contents favours ions of smaller radius. Apart from the thickness and composition of the glass membrane, its hygroscopicity and durability are also related to the electrode response. It is well known that glass electrodes should be soaked before use, as this

operation produces a hydrated layer on the membrane surface. This layer consists of anionic sites which attracts cations of appropriate charge to size ratio. The useful life-time of the electrode mainly depends upon the rate of dissolution of the hydrated layer which varies from a few weeks to several years. The formation of the hydrated layer depends upon the hygroscopicity of the glass. The glass keeps on dissolving with further hydration of additional dry glass so as to maintain the thickness of the hydrated layer at a certain value. The dissolution of the hydrated layer, however, depends upon the composition of the glass and the nature of the sample solution. The glass used for the preparation of the electrode membrane should be of medium hygroscopicity. For correct functioning of the electrode the optimum water uptake is usually in the range 50 - 100 mg/cm³. The effect of hygroscopicity on electrode function is given in Table 2. Non-hygroscopic glasses such as quartz are found to produce little or no electrode function.

TABLE (2) Relation between composition, water uptake and response of electrode (11)

Glass Membrane	water uptake mg/cm ³	Electrode function (mV)
100% SiO ₂	<10	≈0
2% Na ₂ O + 98% SiO ₂	22	15
4% Na ₂ O + 96% SiO ₂	30	35
10% Na ₂ O + 90% SiO ₂	40	47
14% Na ₂ O + 86% SiO ₂	63	59
20% Na ₂ O + 10% CaO + 70% SiO ₂	≈60	59+ (Nernstian)
20% Na ₂ O + 5% CaO + 75% SiO ₂	75	59+ (Nernstian)
20% Na ₂ O + 80% SiO ₂	110	54
25% Na ₂ O + 75% SiO ₂	135	40
30% Na ₂ O + 70% SiO ₂	160	23
40% Na ₂ O + 60% SiO ₂	320	12

The soaking of the glass membrane is necessary from the point of view that the movement of ions in the glass is aided by its hydration. The diffusion coefficients of cations in hydrated glass are about 1000 times greater than in dry glass. This may be due to the presence of water facilitating ionic movement in the membrane and lowering the electrical resistance by lowering the energy barrier for the transfer of protons from the solution to the gel layer. Therefore, these hydrated layers are considered to be essential for proper electrode functioning.

But it is also seen that glass electrodes work very well in molten salts. A borosilicate glass when used in fused ammonium nitrate produced a response equal to the electrode of similar composition when used in aqueous solution in the order of $\text{Na}^+ > \text{Ag}^+ > \text{Li}^+ > \text{K}^+ > \text{NH}_4^+$. This is due to the fact that at higher temperatures the mobility of ions is increased due to the decrease in electrical resistance of the glasses. In this case the entire membrane may simply be performing the ion exchange and diffusion characteristics of the hydrated gel layers at room temperatures.

When glass electrodes are soaked in an aqueous solution, the glass membrane swells and produces hydrated layer on both surfaces. According to Moody and Thomas⁽⁴⁾ these layers vary in thickness from 0.05 μm to 1 μm , whereas Rechnitz⁽¹¹⁾ has described such variations between .005 μm to 0.1 μm (i.e. 50 - 1000 \AA). The bulk of the membrane thickness (about 50 μm) remains dry.

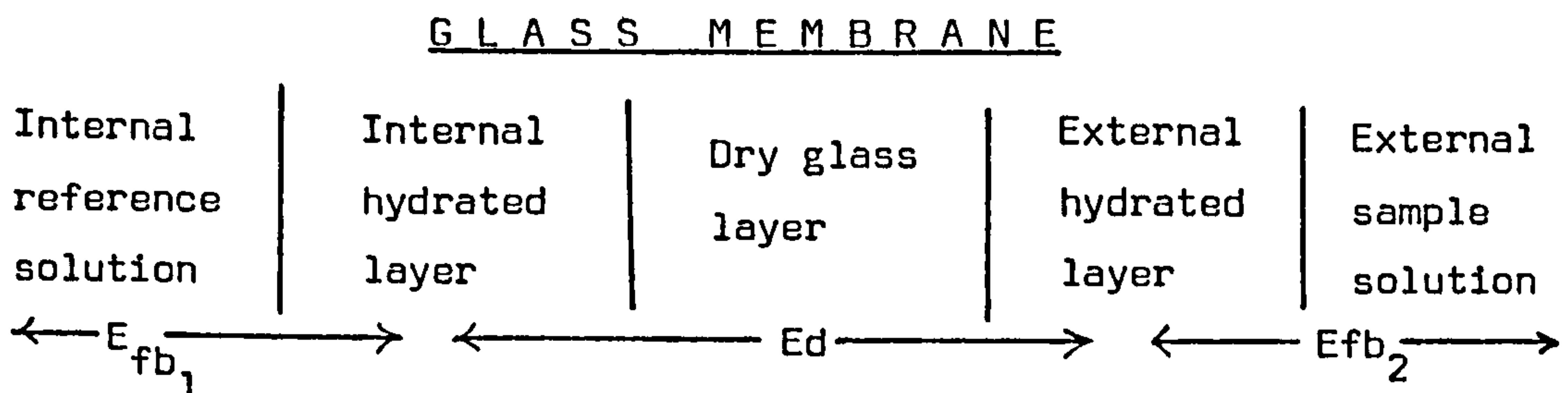

In determining the potential of glass electrode the liquid junction potential at reference electrode/test solution interface is minimised by use of an appropriate solution in the reference electrode. The potential determined is due to glass membrane of the electrode. The net potential of such membrane is the result of boundary potentials at internal solution and sample solution interfaces and a diffusion potential. The boundary potentials result from ion-exchange reactions at the membrane interfaces, e.g.



where H^+ from solution exchange with Na^+ in the gel layer. The diffusion potential is related to the mobilities of the hydrogen and sodium ions in the hydrated gel. The resulting potential E is given by:

$$E = E_{fb_1} + E_d + E_{fb_2} \quad (3)$$

where E_{fb_1} is the phase boundary potential at reference solution/membrane layer interface, which remains constant due to constant concentration of the solution inside the electrode. E_d is the diffusion potential in the glass membrane and also remains constant. Whereas, E_{fb_2} is the phase boundary potential at sample solution/membrane interface which depends on the ionic activity of the sample solution; and any change in the activity of the ions will result in a change of the phase boundary potential alone. Therefore, the resulting Nernstian potential of the glass electrode depends upon E_{fb_2} only, as the potential of internal reference electrode also remains constant. Hydrogen ions selectively penetrate the glass membrane to yield the electrode potential. Although it is true that hydrogen ions undergo exchange across the solution hydrated layer interface, and do not penetrate the glass membrane, for the electrode to function the current must pass through dry glass as well as the hydrated phase and it is believed that the charge is carried out through dry glass portion by an ionic mechanism

involving ions as a charge carrier. In the case of sodium silicate glass, the current is carried by the sodium ions moving through the immobile anionic network. Not a single cation moves through the entire thickness of the dry glass membrane, however, for the charge is transported by an interstitial mechanism by which each charge carrier only needs to move a few atomic diameters before passing on its energy to another carrier. In mixed potassium-sodium silicate glass both cations carry current, though not necessarily in equal proportions.

The selectivity of the glass electrode is influenced by the glass composition and relatively small changes in composition can result in large changes in selectivity. As the sodium and other alkali metal ion selective electrodes have a higher sensitivity towards hydrogen ions, therefore for useful results the measurements must be carried out at fairly high pH. Moreover, as the response and selectivity of the glass electrode depends on the equilibrium constant of the ion exchange reaction and mobilities of the relative ion in the hydrated glass layer therefore the electrode must be properly soaked in a solution of the strong electrolyte containing the primary cation. The generation of the hydrated layer can require from a few hours to several days, depending upon the composition of the glass. The sensitivity of the glass electrode potential may also be affected by improper choice of reference electrode, especially in the case of cation glass electrodes. For example, in the case of the potassium electrode, the use of a calomel electrode cannot be proved satisfactory because of leakage of potassium ions from reference solution into sample solution, thus affecting the activity of the potassium ions. In such a case lithium trichloroacetate is found to be quite satisfactory as the reference electrolyte. This also takes into account the fact that both ions of the reference solution should have equivalent conductivity, which avoids the creation of a high

junction potential.

Glass cation responsive electrodes have many applications in different fields of analysis. The most common application is in direct potentiometry where measured potential is directly related to the concentration or activity of the solution species. Cation sensitive glass electrodes are used for reaction rate measurement⁽⁷⁵⁾ and in precipitation titration of potassium, rubidium, ammonium and silver with calcium tetrphenylborate solution⁽⁷⁶⁾. The use of the electrodes has also been reported in applications to complex formation studies⁽⁷⁷⁾. Sodium ion-selective electrodes are reported⁽³⁰⁾ to be at least as good as flame photometers for the analysis of foods, beers confectionery, suspensions and similar systems where the flame photometric method often requires solution pre-treatment or is subject to interference. The sodium electrode has a wide application in monitoring low concentrations (0.0001 ppm level) of sodium in boiler waters⁽⁷⁸⁾ and has also been used to check the salt content of the water for industrial purposes⁽³⁰⁾.

Glass ion-selective electrodes are used for process monitoring control in industries to characterise the composition of the solutions and to provide the rapid information which may be used to operate a controller or as a process computer input. In a variety of processes and waste monitoring systems, the control of pH is necessary and for this the use of pH electrode is well established. For example, in pollution studies, during continuous monitoring of total cyanide contents in a stream, knowledge of pH is necessary; as these measurements can only be carried out in alkaline medium.

Glass electrodes are also used by biochemists and clinicians for continuous monitoring in vivo as well as rapid in vitro measurements of sodium and potassium ion level in blood, serum, urine and spinal

fluids, without serious disturbances to living organism. This is because of the insensitiveness of the glass membrane towards oxidation reduction reactions, because they are not greatly affected by proteins and because they are indifferent to anions in general. Khuri⁽⁷⁹⁾ has mentioned a detailed description about the use of hydrogen, sodium and potassium ion-selective electrodes. Hydrogen ion selective electrodes are used for measurement of pH in situ which avoids the loss of CO₂ to the ambient air. Also Khuri has used sodium glass electrode for measuring sodium ion-activity in blood in vivo and in vitro, and potassium electrodes for monitoring potassium ions in proximal tubular fluid and plasma. Annino⁽⁸⁰⁾ has determined sodium in urine and has shown that results are in compromise with flame photometric results. In quality control of clinical electrolyte solutions, Pearson and Elstob⁽⁸¹⁾ have shown the use of sodium ion-selective electrode as reliable as other methods such as flame photometry and titrimetry. The miniature versions of the electrodes have quite a number of applications in biomedical including continuous determination of intercellular sodium and potassium ion activities in muscle cells of crabs and lobsters⁽⁸²⁾; also in flowing blood streams and other static body fluids⁽⁸³⁾.

SOLID-STATE MEMBRANE ELECTRODES

Certain chemical compounds such as metal salts are capable of carrying an electric current through their structure by the movement of one of the constituent ions, especially when the compound is crystalline. To take advantage of this transfer mechanism, investigations were carried out to develop such sparingly soluble salts and their mixtures for use in ion-selective electrode membranes. Such membranes produce a selective reaction at the interface of a crystal with solutions containing an ion that reacts with the ion that moves through the crystal. This produces a potential across the interface due to the energy change associated with the reaction, which in turn is a function of the activity of the ion involved in this reaction. The potential produced in such cases should follow the potential-concentration relationship defined by the Nernst equation.

The solid-state sensors used for this type of ion-selective electrode should basically be imporous, have a very low solubility, be mechanically stable, chemically inert and should have the ability to equilibrate very quickly with the ions to be measured in the sample solution and also show good selectivity. It should be available as large crystals and exhibit minimum photo-electric response⁽⁴⁾. It may not be possible to make an electrode of the second kind if the metal is unstable in the presence of air and water, for example, La/LaF₃ or Ba/BaSO₄⁽²⁸⁾. The membrane is fixed at the end of a non-conductive and chemically inert tube. In single crystal membrane electrodes the electrical contact is made through a suitable electrolyte containing chloride and anion common to the membrane and using a suitable internal reference electrode (Figure 3). Coleman⁽¹⁵⁾ has modified this system by using a doped solid connection to the inside of the membrane system. Durst and Taylor⁽⁸⁴⁾ have replaced the solution by filling the

electrode with a gel, saturated with the appropriate solute. Such modification allow the electrodes to be used in the horizontal or vertical position.

This work led to the use of lanthanum fluoride⁽⁸⁵⁾ as an active portion of the electrode which by its virtue of conductivity to fluoride ions alone is highly selective. There are many compounds which could be used for this purpose but these do not possess the property of conductivity. Such materials can, therefore, be used for membrane purpose on the basis of electrodes of third kind by doping with a semi conductor material provided they contain an anion or cation in common with it. Silver sulphide is proved to be the best matrix for such type of electrodes because of its low solubility and higher ionic semi conductivity. Solid state halide electrodes⁽⁸⁶⁾ as well as a few other electrodes are based on this system. Electrodes of fourth kind can also be prepared by adding an additional dopant to the membrane containing an anion or cation in common with the initial dopant. Farren⁽⁸⁷⁾ has reported a sulphate electrode containing such a sensor, that is $\text{Ag}_2\text{S}/\text{PbS}/\text{PbSO}_4$. Also Rechnitz, Fricke and Mohan⁽⁸⁸⁾ have produced a similar electrode having membrane composition of 32 mole % Ag_2S , 31 mole % PbS , 32 mole % PbSO_4 and 5 mole % Cu S .

In the membrane crystal of the solid state electrode, at least one lattice ion is involved in the conduction process. This ion has the smallest ionic radius and the lowest charge. The ion moves between the vacancy sites in the crystal lattice and the vacancy at the crystal lattice is so tailored and is so powerfully selective that it only accepts the ion of that particular size, shape and charge; with the result that no other ion can enter that vacancy and take part in the conduction process and potential response of the electrode. All crystal lattices have such vacancies but they must show a good deal of ionic conductivity so as to be potentially useful as electrodes; that is,

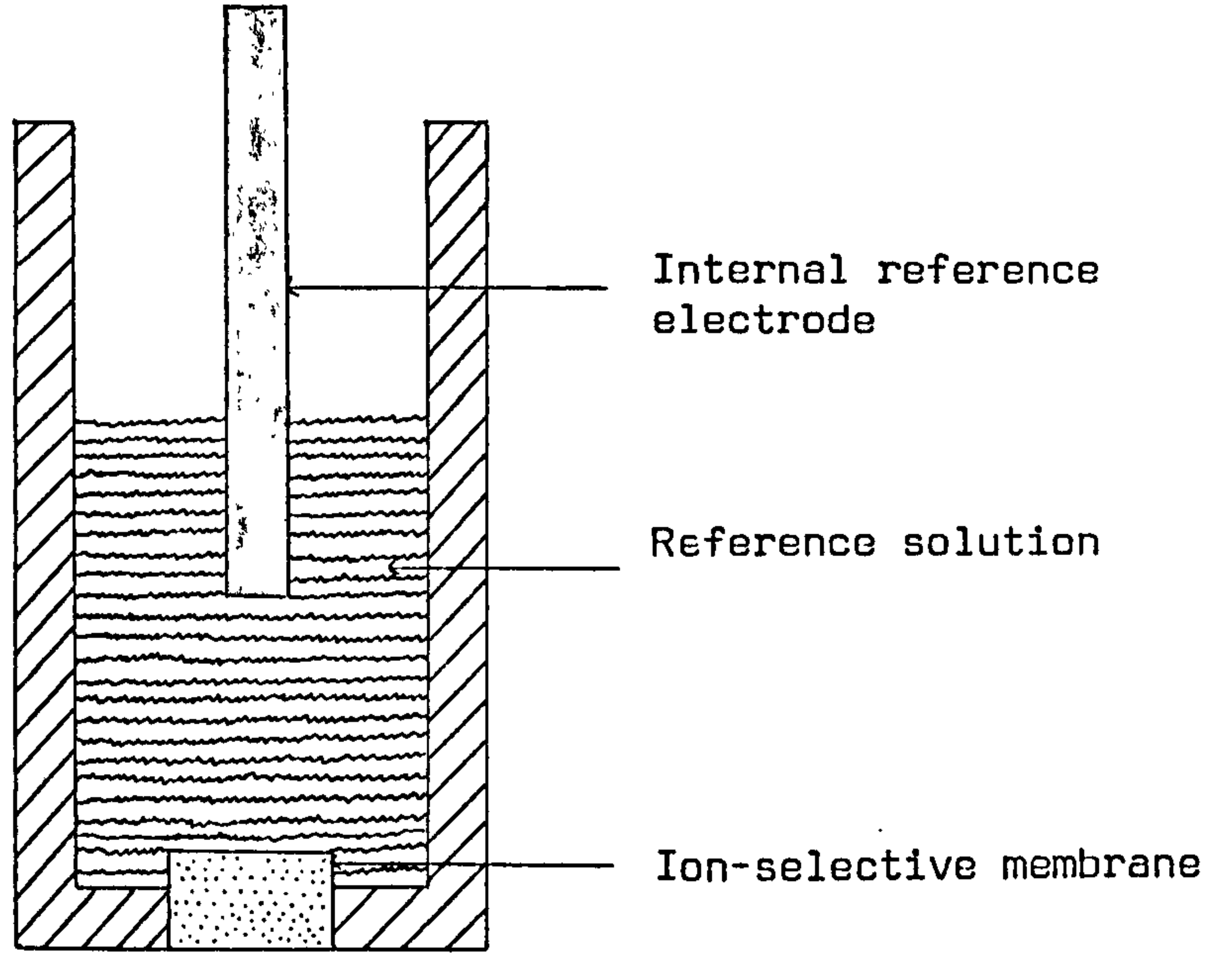

Solid-state (single crystal: Polycrystalline; mixed crystal) membrane electrode.

Figure (3)

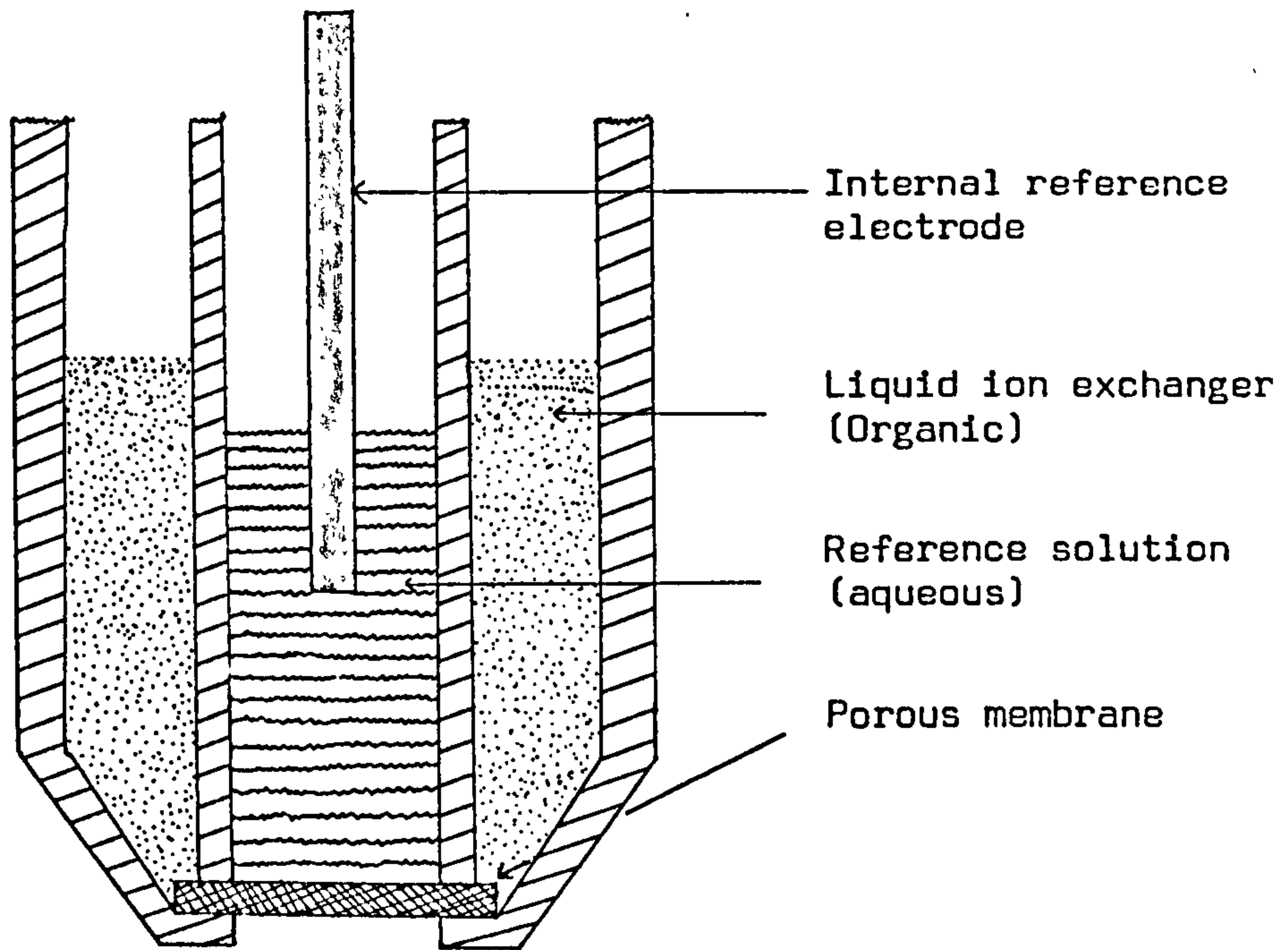

Liquid ion-exchange membrane electrode

Figure (4)

ions must have freedom to leave their normal lattice and fall into other vacancies. This provides a conduction path through the crystal by defect migration.

The first commercial solid-state electrode was developed by Frant and Ross of Orion Research Inc.⁽⁸⁹⁾; for the selective determinations of fluoride ions. The membrane of the electrode was made from a single crystal of lanthanum fluoride having low resistivity which was further reduced by doping with europium to improve the room temperature conductivity. Reagent grade chemicals frequently contain sufficient impurities to produce "structure sensitive" enhanced conductivity at room temperature which is well above the intrinsic conductivity of the pure material⁽⁹⁰⁾. The membrane of 1 cm in diameter and 1 to 2 mm thick is sealed to the end of a rigid polyvinylchloride tube with epoxy cement, using 0.1 M NaCl and 0.1 M NaF solution in contact with Ag/AgCl reference electrode, whose potential is fixed by the chloride ion activity and fluoride ion activity controls the potential of the inner surface of the lanthanum fluoride membrane. Thus the potential varies with the change in fluoride ion activity on the outer surface of the membrane. Moody and Thomas⁽⁴⁾ have described the measuring cell as:

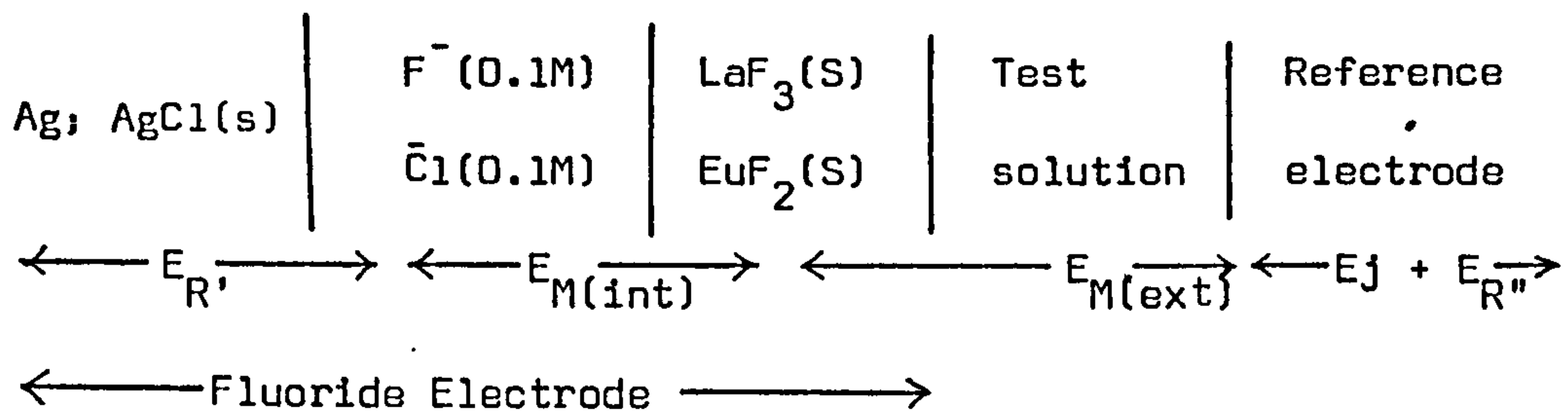

and e. m. f., E is given by:

$$E = E_{R'} + E_{M(int)} + E_{M(ext)} + E_J + E_{R''} \quad (4)$$

As potentials $E_{R'}$ and $E_{M(int)}$ are constant due to fixed concentration of fluoride-chloride solution, the equation can be given as:

$$E = E^0 - 2.303 \frac{RT}{F} \log a_{F^-} \quad (5)$$

where E is the total measured potential; and E^0 is the algebraic sum of the potentials of the silver-silver chloride electrode, the saturated calomel reference electrode, the liquid junction potential between test solution and the reference electrode and the potential across the membrane when fluoride activity in the test solution is Unity. The actual value of E^0 for any ion-selective electrode, will depend on the choice of internal and external reference electrodes, as well as the internal reference solution, and the magnitude of the liquid junction potential. The above equation holds good over a range of 1 M to 10^{-6} M for fluoride ion activity, but this range is restricted by pH. With further decrease in activity the potential tends to become constant, presumably because the lanthanum fluoride from the membrane then contributes more fluoride ions to the solution than are originally present⁽⁹¹⁾.

In lanthanum fluoride electrodes, the charge is transported by moving fluoride ions. There does not seem to be any significant interference from common anions, such as, halides, nitrate, sulphate, and bicarbonate. Neither phosphate nor acetate has any significant effect. The only major interference is from hydroxide ion at higher pH where $(OH^-) \geq (F^-)$. This is attributed to their similar size and charge which presumably causes hydroxide ion to penetrate the crystal and contribute to the diffusion potential⁽⁸⁹⁾. But it has also been suggested⁽⁴⁾ that when an equilibrium of the type:

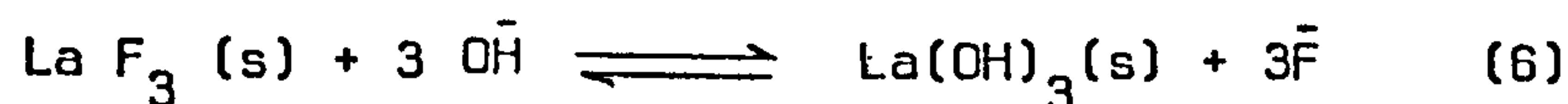

takes place, fluoride ions are released which raises the sample fluoride level to give a more negative potential. The useful pH range of the electrode is limited because it varies with the fluoride ion activity or concentration; lower the fluoride level more restricted is the pH range. Also at pH 4 - 5 the formation of HF and HF_2^- lowers the fluoride activity and give more positive readings. But it is

reported⁽⁴⁾ that, even below pH 5, the electrode is still responding correctly to the fluoride that remains uncomplexed, with a near Nernstian slope of about 60 mV per decade. Thus it is quite realistic to quote a proper pH range of 0 to 11 for 10^{-1} M fluoride rather than 5 to 11; similarly pH range for 10^{-5} M fluoride is 0 to 8.6.

Buffle, Parthasarathy and Haerdi⁽⁹²⁾ have studied the phenomenon limiting the sensitivity of the fluoride ion-selective electrode. According to them although the interference of electrolyte ions or fluoride impurities play a part in this lower detection limit, it seems that the adsorption of fluoride ions at the membrane-solution interface and the solubility of the electrode crystal are two principal parameters.

Lingane⁽⁹¹⁾ found that in titration of fluoride ions with thorium, lanthanum and calcium using the lanthanum fluoride electrode, the largest potential jump is obtained with lanthanum and this is enhanced in presence of 60 to 70% volume percent of ethanol⁽⁹³⁾. Fluoride complexes with iron(III) aluminium (III), calcium (II) and magnesium (II) affect the response of the electrode. Errors can be avoided by using 'total ionic strength adjustment buffer' (TISAB) which consists of 10^{-3} M sodium citrate, 1.0 M sodium chloride, 0.25M acetic acid and 0.75M sodium acetate⁽⁹⁴⁾. This releases the fluoride ions by preferentially complexing metal ions as citrate complexes and maintains the pH of the solution at about 5.5. This latter prevents the formation of HF and HF_2^- as the dissociation constant of HF is 4.7. Furthermore, in cases where samples contain aluminium or iron more than 10% of the fluoride present, disodium CDTA (cyclo-hexylene dinitrilo tetra acetic acid or 1,2-diaminocyclohexane N,N,N',N' tetra acetic acid) is used instead of citrate⁽⁹⁵⁾.

A single crystal fluoride membrane is preferable to a mixed crystal membrane in that the mixed fluoride membrane exhibits a higher

electric bulk resistivity and tends to give a somewhat noisier electrode, as is the example of $\text{LaF}_3 - \text{NdF}_3$ ⁽⁹⁶⁾.

Farren ⁽⁹⁷⁾ has reported a non-porous $\text{LaF}_3 - \text{CaF}_2$ (10 - 50% CaF_2) electrode, but Moody and Thomas ⁽⁴⁾ have suggested that calcium fluoride is too insensitive, since the solubility product $K_{sp} = 3.9 \times 10^{-11}$ would in principle generate about 4×10^{-4} M or 8 p.p.m. of fluoride. The other possible materials suggested are scandium, yttrium, lead and bismuth fluorides. Bismuth trifluoride membranes can be produced by compression but chloride and sulphate interfere seriously.

A considerable number of papers have been published on the use of fluoride solid-state electrodes. A brief survey is also given by Light ⁽⁴⁷⁾, Weber ⁽⁴⁴⁾, and Moody and Thomas ⁽⁴⁾; only a few applications are mentioned here. Apart from direct potentiometric analysis of fluoride, the electrode is employed for study of dissociation constant of hydrogen fluoride ⁽⁹⁸⁾, metal-fluoride association constants ⁽⁹⁹⁾, and stability constants ^(100,101) of the metal fluorides, and in potentiometric titrations ⁽⁹¹⁻⁹³⁾. Also it has been used in studies of fluoride determinations in water ^(102,103), rocks ^(104,105), cane sugar ⁽¹⁰⁶⁾, Urine ^(107,108), beverages ⁽¹⁰⁹⁾, tooth enamel ^(110,111), organic compounds ⁽¹¹²⁾, bone ⁽¹¹³⁾, vegetation ^(114,115), tooth-paste ⁽¹¹⁶⁾ petroleum processing ⁽¹¹⁷⁾ and aerosols ⁽¹¹⁸⁾.

Another well developed solid state electrode is that based on a polycrystalline silver sulphide membrane and is highly selective towards silver and sulphide ions, down to 10^{-7} M under proper conditions, because of its low solubility and rapid equilibration with both ions. Though on the basis of its solubility product $K_{sp} (\text{Ag}_2\text{S}) = 6.2 \times 10^{-52}$, the electrode should respond to 10^{-17} M silver and 10^{-18} M sulphide ions which is not possible due to difficulties in using dilute solutions of sulphide. The solutions must be oxygen free to avoid the formation of thiosulphates and sulphates. Also, the electrode does not respond to HS^- which forms in

aqueous solution, as:

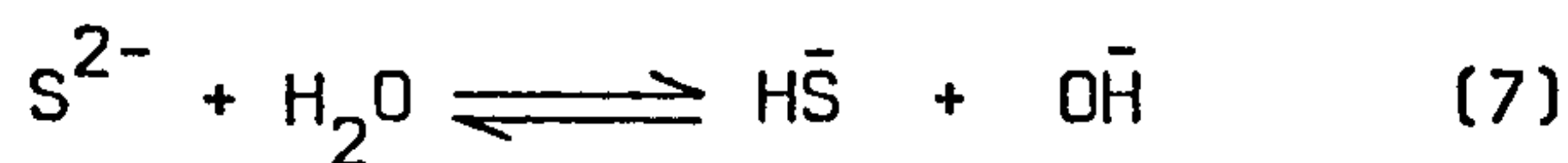

In order to prevent the equilibrium proceeding to right hand side, the solution should be prepared in highly alkaline medium, maintaining the pH above 13.0, the second dissociation constant of hydrogen sulphide. Orion⁽¹¹⁹⁾ have produced a sulphide antioxidant buffer (S.A.O.B.) containing sodium hydroxide, sodium salicylate and ascorbic acid, which greatly retards air oxidation of sulphide ion solution and maintains solution pH at a highly alkaline level, ensuring that the sulphide present occurs chiefly as sulphide (II). In present studies it has been observed that the use of 1M sodium hydroxide solution is adequate well in preventing the formation of HS⁻. The electrode membrane is compact and non-porous, and is superior to metal or Ag/Ag₂S electrode, and is not attacked by oxidizing and reducing agents. The electrode functions through movement of silver ions which carries the current, i.e. silver is the mobile ion in the silver sulphide crystal. The potential response of the electrode, therefore, depends upon the concentration of the silver ion at the membrane surface. Thus the electrode response towards anions depends on the solubility product of the silver salt of the anion in the test solution as this governs the concentration of the free silver at the membrane surface. The e.m.f. of the cell is:

$$E = E^0 + 2.303 \frac{RT}{F} \log a_{Ag^+} \quad (8)$$

A very small amount of silver is generated by the membrane even when test samples contain no silver⁽⁴⁾. The resulting silver ion activity which is dependent on the sulphide ion activity of any test sample is calculated from:

$$a_{\text{Ag}^+} = \sqrt{K_{\text{S}}(\text{Ag}_2\text{S})/a_{\text{S}^{2-}}} \quad (9)$$

thus the equation becomes:

$$E = E^{\circ'} - 2.303 \frac{RT}{2F} \log a_{\text{S}^{2-}} \quad (10)$$

where $E^{\circ'}$ incorporate an additional factor involving the solubility product K_{S} of silver sulphide.

The Orion instruction manual for the electrode 94 - 16 reports that the electrode malfunctions only in the presence of mercury which forms mercury (II) sulphide. The response time of the electrode observed personally, as well as reported by Light⁽¹⁰⁾, using various solutions is rapid, i.e. within a few seconds. Moody and Thomas⁽⁴⁾ have discussed this point with reference to electrodes produced by different manufacturers, in detail.

The silver sulphide electrode can be used for direct potentiometric analysis and titrations of sulphide and silver ions^(120,121). The electrode has wide applications⁽³⁹⁾ in pollution monitoring in industrial wastes in liquid as well as in air. Also sulphide levels in drilling mud are of great interest to petroleum chemists and in the paper industry, the sulphide concentrations in pulping liquor can be measured. In some of the applications the electrode can also be used for automatic argentometric determinations⁽¹²²⁾, and measurements of sulphide^(119,123), and cyanide contents^(124,125) in water; as well as in determinations of thiols^(126,127), disulphide groups in proteins⁽¹²⁸⁾, hydrogen sulphide and methylmercaptan from sulphur containing amino acids⁽¹²⁹⁾, sulphide in cigarette smoke⁽¹³⁰⁾, and hydrogen sulphide in beer⁽¹³¹⁾.

The silver sulphide electrode is further modified for use as a selective electrode for other divalent cations and monovalent anions. Some metal sulphides which have the ability to be used as a membrane

in electrodes cannot be employed directly due to the lack of sufficient conductivity. Also silver halide salts are mixed with silver sulphide due to their physical properties.

When sulphides of copper, zinc, cadmium or lead are incorporated with silver sulphide into the membrane, electrodes produced can be responsive to zinc, copper, cadmium or lead (II) ions as a result of the equilibrium with the sulphide ions:

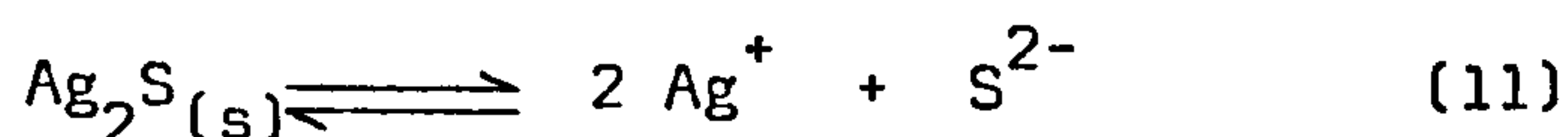

where MS is the metal sulphide.

The activity of the divalent metal ion in the sample solution fixes the concentration of the free sulphide ion on the membrane surface, which in turn fixes the concentration of free silver ion. Hence the electrode responds in a Nernstian manner to the divalent metal ion activity and the electrode still transports the charge through movement of silver ions. But an important condition is that the solubility of divalent metal sulphide be greater than that of silver sulphide to ensure that silver sulphide is always present at the surface⁽¹³⁾. At the same time the value of $K_{S(\text{MS})}$ must be sufficiently small so that the level of M^{2+} in the sample solution, produced from the solubility of MS is small in comparison to the level of the ions which are expected in the sample. According to Ross⁽¹³²⁾, the silver ion activity at the sample membrane interface assuming that the solution contains no silver ion, is determined by the following two equilibria:

$$a_{\text{Ag}^+}^2 a_{\text{S}^{2-}} = K_{S(\text{Ag}_2\text{S})} \quad (13)$$

$$a_{\text{M}^{2+}} a_{\text{S}^{2-}} = K_{S(\text{MS})} \quad (14)$$

Solving these equations for silver:

$$a_{\text{Ag}^+} = \left[\frac{K_{S(\text{Ag}_2\text{S})}}{K_{S(\text{MS})}} \cdot a_{\text{M}^{2+}} \right]^{\frac{1}{2}} \quad (15)$$

which when substituted into the Nernstian equation (6) for a silver ion conducting system, yields:

$$E = E^0 + 2.303 \frac{RT}{2F} \log a_M^{2+} \quad (16)$$

The electrode therefore behaves in solutions containing M^{2+} but not silver ions, as selective towards M^{2+} .

Hirati et al⁽¹³³⁾ found a hot pressed mixture of PbS, CuS and Ag₂S gave a rapidly responding lead ion-sensitive electrode. They⁽¹³⁴⁾ have also used a Cu₂S ceramic electrode for copper(II) activities and found a useful analytical range of 10⁻⁸ to 10⁻¹M copper(II) ions.

Introduction of these electrodes have limited interferences to just silver and mercury cations. In case of copper, the presence of iron(III) ion can be removed by adjusting the pH between 4 to 6; above pH 6 copper will precipitate as hydroxide⁽⁴⁾. Moreover, in the acidic region, the selectivity toward divalent ions at lower limits decreases because of hydrogensulphide formation⁽²⁶⁾. Hirata and Higashiyama have reported that the electrodes based on selenides suffers smaller interference from hydrogen ion.⁽¹³⁵⁾

Electrodes of this type are the cadmium, lead, copper, cyanide, and thiocyanate electrodes. According to Moody and Thomas⁽⁴⁾, Orion 94 - 58 thiocyanate electrode has been withdrawn. Manufacturers have given a good deal of information regarding the possible uses of these mixed sulphide electrodes, and Light⁽⁴⁷⁾ and Weber⁽⁴⁴⁾ have given comprehensive lists of uses. The CuS-Ag₂S electrode has also been used for potentiometric titrations in non-aqueous media⁽¹³⁶⁾; as these mixed crystal electrodes work well in both aqueous and non-aqueous media, they have considerable importance. The lead electrode (PbS + Ag₂S) has been used by various workers for determination of sulphate⁽¹³⁷⁻¹³⁹⁾.

SILVER HALIDE ELECTRODES

Electrodes prepared from pure silver chloride^(140, 141) give reproducible results, but have poor mechanical properties, the membrane being quite soft and easily damaged. Electrodes prepared from an intimate mixture of silver chloride and silver sulphide obtained by addition of two fold stoichiometric excess of silver nitrate to the solution of sodium sulphide and sodium chloride, are more robust and suitable for routine working⁽¹⁴²⁾. Moreover, silver chloride has a pronounced photoelectric effect and a high resistance at room temperature. Similar effects are observed for bromide and iodide electrodes. Pellets made from $\text{Ag}_2\text{S} - \text{AgBr}$ and $\text{Ag}_2\text{S} - \text{AgI}$ are believed to contain substantial amounts of the compounds Ag_3SBr and Ag_3SI , whereas $\text{Ag}_2\text{S} - \text{AgCl}$ is a true mixture. These mixtures produce, in all cases, substantially imporous, mechanically very strong and highly water insoluble electrode membranes. In these cases the use of silver sulphide is as a matrix which is chemically inert and with high ionic conductivity through which silver ions are free to move. Also silver sulphide being more insoluble than silver halide will not react with halides in the solution.

The main advantage of the silver halide solid state electrode over silver - silver halide electrode is that the former is less sensitive to redox effects, although difficulties are to be expected if strongly reducing component lead to the deposition of silver on the membrane surface. Homogeneous solid state membrane electrodes appear to have a longer life than do the heterogeneous ones described later, presumably because of the permeation in the heterogenous solid-state membrane⁽¹⁶⁾.

The mechanism of the silver halide electrode has been discussed by Frant et al⁽³²⁾. When used in a solution of halide (X^-) ions, the

solubility equilibrium

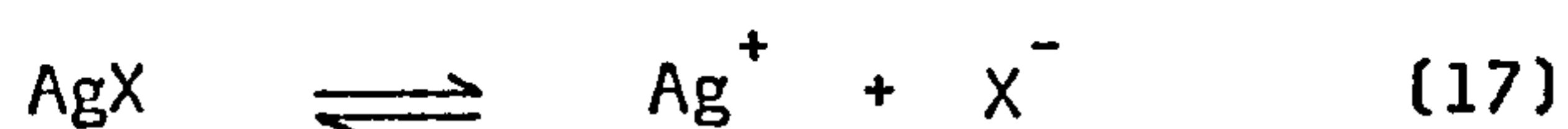

requires that the silver ion activity be given by:

$$a_{\text{Ag}^+} = K_{\text{S}(\text{Ag X})} / a_{\text{X}^-} \quad (18)$$

where $K_{\text{S}(\text{Ag X})}$ is the solubility product of silver halide. For any halide activity in the sample, a definite amount of silver ions exists at the membrane surface. Since the Ag X membrane is a silver ion sieve, a potential is developed which reflects the sample silver activity expressed in terms of halide. The Nernstian equation for such electrode is:

$$E = E^0 - 2.303 \frac{RT}{F} \log a_{\text{X}^-} \quad (19)$$

The electrode behaves in halide solutions as if X^- ions were actually moving through the membrane.

Unlike glass electrodes, the interferences in the case of these electrodes may happen only due to the reaction with interfering ions on the membrane surface, because the condition of size and shape of the interfering ions prevent diffusion into the membrane crystal. In such a case interfering ions form a more insoluble silver salt⁽¹³²⁾, e.g.



If the $\text{SCN}^- / \text{Br}^-$ activity ratio is greater than $K_{\text{S}(\text{Ag SCN})} / K_{\text{S}(\text{AgBr})}$, then a layer of silver thiocyanate will be found on the membrane surface and the electrode becomes a thiocyanate electrode.

In the presence of cyanide, the $\text{Ag}_2\text{S} + \text{AgI}$ membrane will tend to dissolve according to the equation:

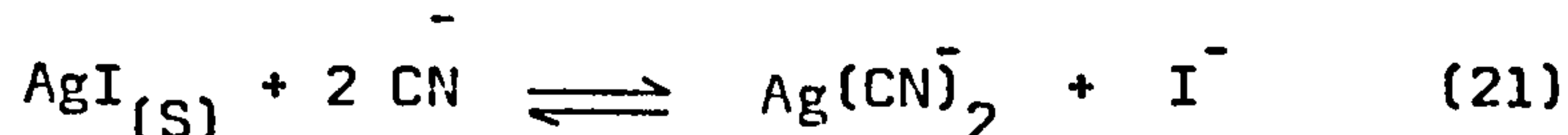

In this case, however, the reaction proceeds virtually to completion at equilibrium with the consumption of silver iodide from the membrane and the production of iodide ions. The iodide and cyanide ions inter-diffuse

between the eroding electrode surface and the sample solution. If an appropriate diffusion barrier is placed on the membrane surface, then a steady state is quickly established in which the cyanide level at the solid membrane surface is virtually zero, while the iodide level is very nearly one half the sample cyanide ion concentration. Thus, under steady state conditions the concentration of iodide ions sensed by the electrode is half the cyanide ion concentration and the system responds in Nernstian manner as a cyanide electrode.

Some of the solid state electrodes based on silver sulphide matrix are modified to be used for other purposes. For example, Rechnitz and Llenado^(143,144), as well as Mascini and Liberti⁽¹⁴⁵⁾ have used cyanide solid state electrodes for enzyme analysis; whereas Alexander and Rechnitz⁽¹⁴⁶⁾ have used silver sulphide solid state electrode for automated protein determination.

Apart from this, some workers have used other materials to prepare solid state electrodes. For example, Sharp and co-workers⁽¹⁴⁷⁻¹⁴⁹⁾ have used insoluble organic radical-ion salts to prepare cationic and anionic solid state electrodes for lead, copper, tetraphenylarsonium and perchlorate ions.

HETEROGENEOUS MEMBRANE ELECTRODES

During the development of analytical methods applied to aqueous and non-aqueous solutions attention has been given to the construction and use of the membranes in ion-selective electrodes. As a result a wide range of possible membranes have been produced, which vary in their physical state and the material used. It was considered by early workers that, if slightly soluble salts having a good electric conductivity were incorporated in a membrane, an electrochemical equilibrium might exist in the boundary layers which might produce ion-selectivity.

As membranes prepared from precipitates by compression showed poor mechanical properties, therefore an idea led to the development of a heterogeneous membrane. These membranes are based on ion exchange resins or on precipitates as the active component incorporated in an inert binder material; the latter giving it the required mechanical properties. The active materials that have been used in this type of electrode include insoluble metal salts, metal chelates and graphite.

Pungor and Toth⁽³⁴⁻³⁶⁾ have reviewed these electrodes in some detail and Moody and Thomas⁽⁴⁾ have briefly described the specifications of Pungor-Radelkis heterogeneous ion selective electrodes. A brief survey of the development and use of Paraffin wax, collodion, Polyvinylchloride, Polystyrene, Polyethylene and silicone rubber based precipitate type membrane electrodes has been given by Covington⁽⁹⁾.

In general, heterogeneous and homogeneous membrane electrodes differ from each other only in their physical composition. In both cases only the active material is responsible for the electrode potential; the active centres for the ion-exchange within the membrane are fixed and exhibit no mobility⁽²⁶⁾. Therefore, both classes can be regarded similar to each other, although it may not be possible to make a homogeneous form as in case of ion exchange resins. Pungor and Toth⁽³⁶⁾ have

stressed that the mechanism of the functioning of homogeneous and heterogeneous electrodes is essentially the same.

The structure of this type of electrode consists of a membrane of inert material into which a precipitate or ion exchange resin is incorporated. Depending upon the substance used the electrode will be sensitive to a particular ion. These membranes separate the internal filling solution from the sample solution and the circuit is completed with a silver-silver chloride internal reference electrode and an appropriate external reference electrode.

The value of a particular selectivity constant of a heterogeneous membrane electrodes is a function of the method of their preparation, as the properties of the materials used are of critical importance to the functioning of the membrane. The essential feature of successful electrodes include a suitable grain size and conductivity of the active material, and an adequate ratio of active material to binder to ensure contact between particles to facilitate conduction. According to experience obtained in this work, the use of coarse material caused reduced potential-activity slopes to be obtained generally and a Nernstian slope to be obtained over a very short range of concentration. Pungor, Havas and Toth, have studied the effect of grain size qualitatively by means of a granulometric curve obtained during the preparation of sulphate and chloride ion selective electrodes, and have found the most favourable range of grain size of the precipitates varied from 5 to 10 microns⁽¹⁵⁰⁾. According to Macdonald and Toth⁽¹⁵¹⁾, precipitates which are satisfactory for use in gravimetric analysis will be a good active material for incorporating in a membrane electrode. The ratio of active material to the binding matrix also greatly affects the efficient working of electrodes. Thus for good conductivity the precipitate particles in the membrane should touch

each other. The optimum ratio can be found by using various ratios of the embedded material and the supporting matrix. According to Pungor and co-workers⁽¹⁵⁰⁾, for a sulphate sensitive membrane containing barium sulphate, 30 to 50 percent proved to be the best from the electrochemical and the mechanical points of view. Rechnitz⁽¹¹⁾ has reported that in cases where less than 20 percent of precipitate has been used, electrodes do not develop the Nernstian response and he has recommended a weight ratio of 50 percent. According to Rechnitz at this ratio, the particles of the precipitate are in contact with each other. According to experience obtained in present work, the ratio of the precipitate to supporting material is not the same in all cases but depends on the physical properties of the active material and the kind of the supporting material used. The degree of the cross-linking also determines how well the particles remain embedded in the surface of the final membrane. The final form of the supporting matrix should be mechanically tough, elastic, resistant to cracking and to swelling in solutions and it must be free from pores. Also it should be water repellent and chemically highly inert so as not to react with the solution in which it is used.

The main advantage which these membrane electrodes have over similar electrodes of second kind, e.g. silver-silver chloride electrode, is that the former are insensitive to redox interferences and much less sensitive to surface poisoning. In silver-silver chloride electrodes the potential is established through the couple Ag/Ag^+ which is sensitive to oxidants, whereas the potential determining processes for the heterogeneous membrane electrodes are not noticeably influenced by the presence of common oxidizing or reducing agents.

In 1950, Wyllie and Patnode⁽¹⁵²⁾ have used commercial cation exchange resins supported on methylmethacrylate polystyrene matrix, to prepare heterogeneous membrane sensitive to sodium ions. Later on, in

1957 Tendeloo and Krips⁽¹⁵³⁾ studied a paraffin membrane, incorporating calcium oxalate and a non-ionic detergent, supported on a wire gauze. This electrode responded to changes in the electrolyte concerned but the response was not selective. The introduction of an iodide ion-selective electrode⁽¹⁵⁴⁾ based on silver iodide in a paraffin matrix directed attention to the use of those precipitates that ensure a rapid precipitate exchange reaction on their surfaces. Later a significant development in the field of silicone rubber membrane based electrodes was reported.

The silicone rubber was shown to be an excellent supporting matrix bearing in mind the conditions already mentioned. The silicone rubber membrane based electrodes for other halide electrodes^(7,34,155) and for sulphide⁽¹⁵⁶⁾ were prepared by Pungor and co-workers, by dispersing the appropriate precipitates in a polysiloxane matrix using a certain amount of curing agent. Electrodes based on these investigations of Pungor, have been manufactured by Radelkis Electrochemical Instruments (Budapest). Rechnitz and co-workers^(157,158) have evaluated the commercial form of these electrodes and have reported linear responses within the ranges pI 1 - 6, pBr 1 - 3.5 and pCl 1 - 3. In addition Rechnitz⁽¹¹⁾ has studied the lack of sensitivity of silver halide electrodes towards cations by using difference electrolytes as a source of anions. Macdonald and Toth⁽¹⁵¹⁾ and Materova et al⁽¹⁵⁹⁾ have studied the possibility of making fluoride electrodes based on this cold polymerization process in the presence of a suitable catalyst. Buchanan and Seago⁽¹⁶⁰⁾ have reported silicone rubber based copper electrodes. The work of Rechnitz, Fricke and Mohan, on Pungor type sulphate electrodes shows that this electrode has no great selectivity for sulphate⁽⁸⁸⁾. In the literature a considerable number of publications are available on heterogeneous membrane electrodes. Some examples of silicone rubber membrane electrodes include those selective for copper⁽¹⁶¹⁾, lead⁽¹⁶²⁾,

chromate⁽¹⁶³⁾, cadmium⁽¹⁶⁴⁾, potassium⁽¹⁶⁵⁾, and urea^(166,167). The latter electrode is prepared by covering the active surface of the silicone rubber based ammonium ion-selective electrode with a thin layer of finely ground chemically immobilized urease gel.

Poly(vinylchloride) based electrodes selective to calcium were prepared by Shatkay and co-workers^(168,169), by dispersing tributylphosphate in a mixture of tributylphosphate and 2-thenoyltrifluoroacetone (T.T.A) and have claimed to get comparable results with those obtained with a calcium liquid state membrane electrode. Little interference was observed from sodium, barium and magnesium. Later, this type of heterogeneous electrode was developed by Moody, Oke and Thomas⁽⁸⁾ by dispersing the liquid ion-exchanger in p.v.c. dissolved in tetrahydrofuran, followed by slow evaporation of the solvent at room temperature. The use of such a membrane eliminates the need of a reservoir for the liquid ion-exchanger. Electrodes for calcium^(8,170), nitrate⁽¹⁷¹⁾, potassium⁽¹⁷²⁾ and uranium⁽¹⁷³⁾ have been reported, incorporating this type of membrane. The optimum composition of p.v.c. membranes has been investigated by Griffiths and co-workers⁽¹⁷⁴⁾. Other examples include the potassium ion-selective electrode prepared by dissolving dimethyl-dibenzo-30-crown 10 in 1 ml. of dipentylphthalate and mixing with 10.0 ml of 5% p.v.c. in cyclohexane,⁽¹⁷⁵⁾ as well as by using 5% potassium tetra(p-chloro-phenyl) borate in a given plasticizer, mixed with p.v.c. powder and fusing at 200°C for 20 minutes⁽¹⁷⁶⁾. A choline-ester selective electrode⁽¹⁷⁷⁾ based on a similar membrane is also reported. Smith et al⁽¹⁷⁸⁾ have prepared a miniature solid state potassium electrode for serum analysis by coating silver-silver chloride wire with poly-vinylalcohol-diphenylphthalate valinomycin, to form an ion-selective membrane.

Heterogeneous membrane electrodes based on a thermoplastic polymer

membrane like polythene or meta-cycrylic ester as a matrix, have been reported by Mascini and Liberti and also by Vanloo. Examples of such type of electrodes include those selective for halides⁽¹⁷⁹⁻¹⁸¹⁾, copper⁽¹⁸²⁾, lead⁽¹⁸³⁾, thiocyanate⁽¹⁸⁴⁾, and cadmium⁽¹⁸⁵⁾. Electrodes of Mascini and Liberti type are manufactured by Italian firm of Amel (Milano).

Paraffin bound heterogeneous membrane electrodes were prepared by Shatkay⁽¹⁶⁸⁾. Later Buchanan and Seago⁽¹⁶⁰⁾ reported that when a paraffin membrane impregnated with nickel diglyoximate was used, the electrode did not respond to nickel(II); other example is a paraffin wax bound lead dioxide electrode⁽¹⁸⁶⁾.

Carbon paste electrodes can also be considered as heterogeneous electrodes as they can be used as a matrix for holding the active material. Some electrodes of the carbon paste type have also been reported by Masaric and Dahmen⁽¹⁸⁷⁾, which include electrodes for halide and silver ions.

Another form of heterogeneous type electrode is based on coating platinum wire by simply dipping it in a polymeric material containing poorly soluble active material. The material may be incorporated in p.v.c., epoxy resin, methyl methacrylate or any other suitable polymer, but again it is necessary that the salt particles form a continuous contact from the outer surface of the polymer film to the metal surface underneath. This type of electrode has been reported by Hirata and Date⁽¹⁸⁸⁾, and by Freiser and co-workers^(189,190). According to Covington⁽²⁸⁾ the inner membrane solid contact potential is not particularly well defined and frequent standardisation might be necessary. Alternatively, the electrodes may only be suitable for titrimetric purposes. If the claims made are to be believed, this does not appear to be the case.

Heterogeneous ion-selective electrodes can be used for determina-

tion of individual ionic species by direct and indirect methods. Pungor and Toth⁽³⁵⁾ have described the use of a chloride membrane electrode in the determination of chloride ions in human and horse serum, in the sweat of a new born baby (to demonstrate its use on a very small amount of solution) and in the food industry to determine chloride contents in cheese and cow's milk. They also illustrated its use in the pharmaceutical industry to study organic compounds containing ionic chlorine (e.g. Promethazine HCl) and also after suitable chemical treatment in the covalent form (e.g. chlorpromazine). Havas, Papp and, Pungor⁽¹⁹¹⁾ have determined chloride in analytical grade potassium hydroxide (following the removal of potassium ions on a cation exchange resin), and have used bromide ion-selective electrode for bromide ions in serum and pharmaceutical products. Pungor⁽³⁴⁾ has used electrodes for determination of iodide in mineral waters, cyanide in sewage and industrial waste waters. The results obtained by direct and titrimetric methods were reported to be in very good agreement. Electrodes can also be used in automatic process control for elimination of cyanide with hypochlorite. The other useful determinations include that of cyanide in bromides and hydrolysed amygdalin samples⁽¹⁹²⁾. Pungor and co-workers have reported the use of the sulphide membrane electrode in potentiometric titrations of sulphide and halides in aqueous solutions as the sulphide present does not interfere in the determination of the halides. This is especially important in the photographic industry, where halide ion specific electrodes cannot be used because of poisoning by the sulphide released from gelatin. Also, some electrode has been used for potentiometric studies on organic compounds containing sulphur⁽¹⁹³⁾.

SELECTRODES

Růžička and co-workers have introduced a new solid state electrode under the name of Selectrodes. In all cases, the body of the electrode is made from a pressed graphite rod, the graphite being previously hydrophobized with Teflon to prevent aqueous solution from soaking into it and is mounted in a Teflon tube serving as a electrode body. Electrical contact is made through a stainless steel wire screwed into the rod. Instead of using a crystal or pellet of the sensing material as a membrane, the ion sensitive surface of the electrode is activated by rubbing or hot dipping 2-4 mgs of finely powdered (or colloidal) material to produce a thin layer of the membrane. This is followed by removing the loose particles and hand polishing of the surface to distribute the electro-active material more evenly over the electrode surface and to close the micropores in the electrode material.

In this type of electrode, the electroactive materials which are not available in crystalline form and which cannot be pressed into a pellet, may still be used. The sensitive part of the electrode can be renewed by reactivating with the same material or replaced by trimming 0.1 to 0.2 mm layer from the surface so as to be made selective towards different ions^(194,195). The life-time of the electrodes varies with the electro-active material used, e.g. the copper Selectrode, which is activated by a $\text{CuS}/\text{Ag}_2\text{S}$ precipitate, lasted for more than seven months in continuous use without renewal, whereas the iodide ion Selectrode has to be renewed after only four weeks⁽¹⁹⁵⁾. The active materials so far used in these electrodes are the same as those used in commercially available solid state electrodes. For example, silver halides mixed with silver sulphide, may be used by the procedure already mentioned⁽¹⁹⁶⁾. The halide electrodes⁽¹⁹⁷⁾ are claimed to produce potentials which are in great agreement within a few millivolts of that of the solid state

membrane electrode.

In the case of the copper Selectrode⁽¹⁹⁸⁾ the active material used is $\text{CuS}/\text{Ag}_2\text{S}$, which has proved more sensitive both in pCu measurements and compleximetric titrations than other commercial electrodes tested. For the preparation of cadmium Selectrode⁽¹⁹⁹⁾ different ratio of $\text{CdS}/\text{Ag}_2\text{S}$ were used, which showed that pure cadmium sulphide does not respond to changes in cadmium activity. $\text{CdS}/\text{Ag}_2\text{S}(1:1)$ gave poor sensitivity and a slope of 20 mV/pCd, $\text{CdS}/\text{Ag}_2\text{S}(1:5 - 1:20)$ proved to be optimal for getting Nernstian response; whereas a ratio of 1:40 gave an unstable electrode. Therefore, in consequence^a 1:10 ratio of $\text{CdS}/\text{Ag}_2\text{S}$ was chosen for the preparation of the Selectrode. The response obtained was linear down to 10^{-9} M at pH 6.7 and 10^{-11} M at pH 9.0. The electrode is successfully used in E.D.T.A. titration of cadmium(II) and calcium(II).

In case of calcium⁽²⁰⁰⁾ and potassium⁽²⁰¹⁾ Selectrodes, the membranes are prepared by incorporating dioctyl phenyl phosphate^{on} and calcium salt, and valinomycin respectively, in polyvinylchloride reinforced by a nylon net. In these electrodes a reference paste of calomel (containing solid calcium sulphate in case of calcium ion exchange electrode) is rubbed into the Teflon-graphite surface as internal reference electrode. Covington⁽²⁸⁾ has commented that from experience with mercury filled glass electrodes, these sometimes are quite reliable, but at other times inexplicable jumps of potential take place. The glass-mercury contact at the inner surface could depend on the presence of a small amount of moisture, when the inner electrode may be effectively $\text{Na}(\text{Hg})$ or $\text{Li}(\text{Hg})/\text{OH}^-$ or simply $\text{Hg}/\text{HgO}/\text{OH}^-$. Something similar could be responsible in certain solid-state contact electrodes. Graphite, for example, is known to have $-\text{COOH}$ and $-\text{OH}$ groups on its surface and it is doubtful that all water can be excluded in electrode

construction, or indeed that it is desirable that this should be done. One thing is certain, however, and this is that somewhere in the vicinity of a solid-state internal connection a change in conductance mechanism - electronic to ionic - must take place. Some useful information on selectrodes is given in Table 3.

TABLE 3 Useful range of different Selectrodes

Electro-active Material	Measured ions	Useful range p_M or p_X
Metallic copper	Cu(II)	3 - 1
CuS/Ag ₂ S	Cu(II)	18 - 1
CdS/Ag ₂ S	Cd(II)	11 - 1
PbS/Ag ₂ S	Pb(II)	≈ 5 - 1
AgCl/Ag ₂ S	Cl ⁻	5 - 1
AgBr/Ag ₂ S	Br ⁻	6 - 1
Ag I/Ag ₂ S	I ⁻	7 - 1

LIQUID ION EXCHANGER ELECTRODES

In commercially available liquid ion exchange membrane electrodes (Figure 4) the ion-sensitive part consists of a thin Millipore membrane saturated with an organic ion-exchanger solution. The ion-exchanger used may be in the form of a pure liquid at room temperature which can be used directly as the organic phase of the electrode. Examples of such ion exchangers include liquid organophosphoric acids, such as bis-(2-ethylhexyl) phosphoric acid used as a cation-exchanger; and primary, secondary and tertiary amines, such as trialkylmethylamine, N-lauryl-N-tri alkylmethyl amine, N,N-didodecenyamine, and tri-iso-octylamine, used as liquid anion-exchanger. Alternatively, solid ion-exchanger may be used by dissolving in a suitable water immiscible organic solvent. Typical examples of such solid exchangers are dioctadecylamine, tetraheptyl ammonium iodide, cetyl pyridinium chloride and nonadecylphosphoric acid⁽²⁰²⁾. Apart from this, an electroneutral macrocyclic compounds, which form complexes, especially with alkali metal ions and with ammonium ion and show great stability in non-polar solvents, compared to that in water⁽²⁶⁾, are used as ion-exchangers.

The inert membrane used should be strong, hydrophobic and wettable by Organic solvents. The membranes that have been used include those made from siliconized cellulose acetate, porous flexible plastics, sintered glass, porous Teflon, Dacron, porous Polyvinylchloride, Porvic S, and glass fibres⁽²⁶⁾. Dacron and Porvic however, have been found to be unsuitable and glass fibres have low mechanical strength. A p.v.c. matrix containing the liquid ion-exchangers have also been proposed^(8,171). The membrane disc in the commercial electrode is held in the outer tube of the electrode body by an inner tube holding the internal reference solution. The space between the two tubes is used as a reservoir for the ion

exchanger. The central chamber of the electrode is filled with aqueous electrolyte and a reference electrode. The Millipore material is saturated with the water immiscible organic solvent through a wick into the pores of the membrane from the reservoir.

The solvent used must be highly hydrophobic and in general has a low dielectric constant and a high molecular weight. It should have a low vapour pressure to prevent significant evaporation and a sufficiently high viscosity, so that it does not pass through the membrane pores quickly. Also it must be substantially inert to reaction with the electrode body. Apart from this, other considerations such as availability of the solvent in pure form, hydrophobizing properties and degree of dissolution of the particular active component used, have also to be realised. The commonly available solvents which can be used for this purpose include Chlorobenzene, nitrobenzene, benzene, toluene, xylene, diphenylether, paraffin oil, carbon tetrachloride and chloroform. Some solvents, such as decanol and tri-butylphosphate are polar but being hydrophobic can be used. Mixtures of various solvents may also be used.

The ion-exchanger should be very soluble in the organic phase and insoluble in the solution under test. This condition can be fulfilled by using substances with long hydrocarbon chains in their structure. These organic ion-exchangers bind small ions selectively either at charged sites of opposite sign or in some cases at co-ordination sites. The sites must be capable of entering into a rapid mobile ion exchange equilibrium with the ions of interest. (132)

Various workers are trying to develop different ion exchangers for use in electrodes selective to a particular ion, keeping in view the cost as well as the ease of preparation. One ion exchanger used may have very high selectivity and another may have very low selectivity for the same

particular ion. The ion exchangers which are in common use are described briefly in various publications (4,26,28,132,202,203).

The choice of organic solvent is important in keeping the ion-exchanger in the liquid phase at room temperature. By careful choice of solvent for the liquid ion-exchanger, the mobility of the sites can be adjusted according to the viscosity of the solvent. In any case the solvent must saturate and pass through the membrane. The site density can be adjusted by a suitable choice of solvent exchanger ratio.

Eisenman⁽³⁸⁾ has studied the similarities and differences between liquid and solid ion exchangers and also their usefulness as ion selective electrodes. Solid and liquid ion exchangers are similar in that they both can be made into membrane electrodes selective for cations or anions. Both solids and liquids share the property that the equilibrium boundary e.g. ion exchange - processes as well as non-equilibrium (diffusion - migration) processes contribute to the potential and to the electrode selectivity. The main difference between the two types is that the ion-exchange sites are spatially fixed in the solid membranes, but free to move, in the liquid membrane system. This means that undissociated ion pairs between sites and counter ions, which are immobilized in solids, contribute to the movement of the species in the liquid ion exchangers. This property leads to an important relaxation of the restraint normally found in solids that an ion which is strongly preferred from the equilibrium ion exchange point of view often moves rather poorly so that its full ion-exchange selectivity is not realised in its contribution to the electrode potential. In the liquid ion exchanger, in contrast, an ion can be strongly bound yet still contribute to its full share of ion exchange selectivity to the electrode potential in certain limiting cases, most noticeably when the most dissociated counter ion species are considerably less mobile than the dissociated site species. Because, for the large

organic liquid ion exchange molecules, the mobility of the undissociated species is likely to be independent of the particular (smaller) counter ion bound, the mobility ratio of undissociated species should be of the order of unity, which means that the potential selectivity of liquid ion exchangers will be dominated largely by their equilibrium ion-exchange selectivity properties. Therefore, the selectivity found by equilibrium ion exchange with liquid ion exchange is more likely to be better than that with solid ion exchangers. On the other hand solids offer an opportunity to obtain high selectivity by mobility differences.

Liquid ion exchangers clearly offers a flexibility in designing electrodes for those cations which move poorly in the usual solid exchangers such as glass electrodes. Therefore, liquid ion exchange materials that possesses high selectivity for a particular ion, may be tailor made by appropriate chemical adjustment of the exchanger on the molecular level.

The selectivity of the ion exchange material depends on the nature of the sites in the exchanger which have a high affinity for that particular ion. Also it depends upon the ability of the organic groups to form a very stable complex with the ion sought, but not with the other ion present in the sample solution. The limit of sensitivity of liquid membrane electrode is governed by the solubility of the ion exchanger compounds in water. This solubility should be very low⁽¹⁵⁾. A disadvantage of this type of electrode is due to its very slow leakage of the ion exchanger solution into the test solution which creates the danger of contamination of the test solution. The liquid-liquid interface is subject to stirring and pressure effects⁽¹³⁾.

In the liquid membrane electrode, when it is dipped in a test solution containing the ions to which it is sensitive, ion exchange

takes place at the membrane - sample interface between the organic complex in the membrane and test solution. Through this process, the ions in the sample solution replace the ions in the organic phase, the process transports such particular ions back and forth across the membrane until equilibrium is established. If the test solution is in contact with a reference electrode, the potential developed between the two half-cells can readily be determined by the usual potentiometric device.

Simon and co-workers⁽¹⁶⁾, Koryta⁽²⁶⁾, and Ross⁽¹³²⁾ have described the expressions for the EMF of a cell assembly, consisting of a liquid ion exchange membrane electrodes and an external reference electrode. According to Ross⁽¹³²⁾ the theoretical treatment of such systems in which two or more ions are simultaneously transported is difficult. Eisenman has solved the problem for a few special cases, but it should be pointed out that the analytically useful systems are much more complicated. Further, he has commented that the analytical chemist is only interested in electrodes which behave in a simple Nernstian manner in response to the ion activity level present in his sample. But it is better to be able to predict in advance if a given electrode will be subject to interference in a given sample. Simon and co-workers⁽¹⁶⁾ have given the following equation:

$$E = E^0 + \frac{RT}{ZF} \ln \sum_{i=1}^N U_i K_i a_i \quad (19)$$

in the case where the ligands are situated exclusively in the membrane having no co-ion, and equilibrium exists between the ion 'i' and the ligand at all points in the membrane. The above equation should hold for systems with completely dissociated ligands. Furthermore, if the ligand is mainly in the undissociated mobile form the equation can be given as:

$$E = E^0 + \frac{RT}{ZF} \ln \left(a_A + \frac{U_{BS}}{U_{AS}} K_{AB} a_B \right) \quad (22)$$

where U_{AS} and U_{BS} are the mobilities of the complexes of the ligand with ion A and B respectively. In limiting cases $U_{AS} = U_{BS}$, then the equation takes the form as suggested by Ross⁽¹³²⁾.

$$E = E^0 + \frac{RT}{ZF} \ln \left(a_A + K_{AB} a_B \right) \quad (23)$$

where K_{AB} is the selectivity constant. Further they⁽¹⁶⁾ have described the EMF of the electrode of the electrically neutral ligand type, as:

$$E = E^0 + \frac{RT}{F} \ln \left(a_A + \frac{U_{BS} k_{BS} K_{BS}}{U_{AS} k_{AS} K_{AS}} a_B \right) - \frac{RT}{F} \ln \left(1 + K_{AS} a_A + K_{BS} a_B \right) \quad (24)$$

where U_{AS} , U_{BS} are mobilities of electrically charged complexes within the membrane;

k_{AS} k_{BS} are distribution coefficients of the complexes between sample solution and the membrane.

K_{AS} K_{BS} are equilibrium constant of the interaction of the cations with ligand in the sample solution.

In this equation the second logarithmic term may be neglected relative to the first if the concentrations in the sample solutions are so small that the complex formation in it may be neglected. Furthermore the constants of the first logarithmic term can be expressed as a ratio of the equilibrium constants of the following salt extraction:



and:

$$\frac{U_{BS} k_{BS} K_{BS}}{U_{AS} k_{AS} K_{AS}} = \frac{U_{BS} K_{BS}}{U_{AS} K_{AS}} \quad (26)$$

therefore the equation becomes:

$$E = E^0 + \frac{RT}{F} \ln \left(a_A + \frac{U_{BS} K_{BS}}{U_{AS} K_{AS}} a_B \right) \quad (27)$$

As in most cases U_{AS} is approximately equal to U_{BS} , the selectivity constant of the electrode with electrically neutral ligands are mainly given by the ratios of the equilibrium constants K_A and K_B which again depend on ligand.

Moody and Thomas⁽²⁰⁴⁾ have pointed out that the pore density and the diameter of the membrane pore can influence the stability, response time and selectivity of an electrode. On the basis of the data collected, they have concluded that:

- i. electrodes having membranes with a multiplicity of narrow, well inter-connected pores having superior stabilities.
- ii. time responses are related to the pore system of a particular electrode.
- iii. Sensitivity may be dependent on the size of the interferant species.

Electrodes for different cations and anions are commercially available from Corning^(202,205), Beckman⁽²⁰⁶⁾, Orion⁽²⁰⁷⁾, Radiometer⁽²⁰³⁾ etc. Corning⁽²⁰⁸⁾ have also reported a modified internal reference electrode for direct use in organic ion exchange liquid, thereby avoiding the requirement for an aqueous internal solution. Apart from these, several² non-commercial liquid ion exchange membrane have been reported in the literature.

The first electrode of this type was reported by Ross⁽²⁰⁹⁾ for the determination of calcium ions. This electrode is very important in blood and water analysis. The electrode is based on the calcium salt of didecylphosphoric acid $[(C_{10}H_{21}O)_2 PO.OH]$ dissolved in di-n-octylphenylphosphate^{on} $[(C_8H_{17}O)_2 PO C_6H_5]$. Calcium electrodes are now produced by Orion⁽²¹⁰⁾, Beckman⁽²¹¹⁾, Corning⁽²¹²⁾ and Philips⁽²⁶⁾. The Orion electrode gives a Nernstian response of 29.5 mv perdecade, between 10^{-1} and 5×10^{-5} M. The lower detection limit can be improved by increasing the length of alkyl chain but if this is too large precipitation or gelling may occur. Alternatively, the liquid exchanger concen-

tration can be reduced, but this will increase the resistance and lengthen the response time⁽¹³²⁾. The electrode shows good selectivity to calcium over magnesium and other alkaline earth ions, but zinc(II), iron(II), and lead(II) interfere. Iodide and perchlorate also interfere at about 10^{-3} M due to their solubility in ion exchanger⁽⁴⁾. Hydrogen ions interfere below pH 5.0 and formation of CaOH^+ and Ca(OH)_2 occurs above pH 11.0; the electrode is believed to give correct calcium activity readings below pH 11.0. Orion and Corning electrodes differ in their membrane composition, as the Corning electrode contains a membrane consisting of siliconized porous glass frit whereas the Orion one is based on a flexible membrane of unspecified material. In the Corning electrode the organic phase is unspecified. In Beckman electrode didecyl or dioctylphosphate salts are dispersed in collodion to give a solid form of electrode⁽²¹³⁾. Some other electrodes which are reported by Moody et al⁽⁸⁾, Shatkay et al^(168,169) and Cattrall et al⁽¹⁸⁹⁾, are also in this class of electrode on the basis that liquid ionexchanger is embedded in a p.v.c. matrix. If the definition of liquid exchange membrane electrode is strictly followed so that the ionexchanger must essentially be in liquid form then such electrodes will be the heterogeneous electrode class. A vast amount of literature is available on the application of the calcium electrode especially in biological analysis either for the direct determination of ionized calcium or for studying biological important very fast reactions of calcium ion using flow-through electrodes^(214,215). Other major uses include the determination of ion activity coefficients, dissociation constants, stability constants of complexes, and the determination of calcium in seawater, detergents, soils etc^(4,26).

When the ionexchanger is dissolved in 1-decanol, the electrode shows virtually identical response to calcium and magnesium, which is

the basis for divalent electrode or water hardness electrode. This type of electrode is quite useful in water hardness control, for example, in the study of corrosion and scale formation, in water softening plants and oceanographic research⁽⁴⁾. When the electrode is used in a solution of calcium and magnesium along with an interfering ion the potential E is given by:

$$E = E^0 + 2.303 \frac{RT}{2F} \log (a_{Ca^{2+}} + a_{Mg^{2+}} + K_{CaMgX} (a_{X^{2+}})^2) \quad (28)$$

The other important electrode in the series of liquid ion exchanger electrodes is that for Potassium. The properties of macrocyclic antibiotic compounds, which have been used as ionexchangers in liquid membrane electrodes, have been discussed by Koryta⁽²⁶⁾. Stefanac and Simon⁽²¹⁶⁾ have used the actin homologs (nonactin, monactin and valinomycin) dissolved in carbon tetrachloride or benzene to make electrodes for K^+ having selectivity of 750:1 over Na^+ . Pioda and Simon⁽²¹⁷⁾ originally reported an electrode based on a suspension of nonactin in Nujol-octanol. Later on Pioda, Stankova and Simon⁽²¹⁸⁾ reported a potassium electrode using dilute solution of valinomycin in diphenylether, and obtained a slope of 58.3 mV per decade for K^+ with a selectivity constant of 2.5×10^{-4} for interference by Na^+ . Then Frant and Ross⁽²¹⁹⁾ improved this electrode by dissolving valinomycin in a variety of aromatic solvents, such as nitrobenzene, diphenylether, chlorobenzene or bromobenzene, using 5 to 10% of weight of valinomycin. This electrode gave a desired slope over 10^{-1} to 10^{-6} M with a selectivity constant of 13,000:1 for K^+ to Na^+ . This type of electrode is manufactured by Orion⁽²¹⁹⁾ and Philips⁽²²⁰⁾. Corning⁽²⁰⁵⁾ have reported a potassium electrode using potassium tetrphenylborate $(C_6H_4X)_4BK$. The preferred solvent for the ionexchanger is nitrobenzene. The most satisfactory electrode reported is based on a 1% w/v solution of potassium tetrakis (p-chlorophenyl)borate salt dissolved in a 1:1 mixture

of p-hexylnitrobenzene and 4-nitro-1,2 dimethylbenzene. The selectivity constant of potassium over sodium is about 10^{-2} .

Beckman⁽²⁰⁶⁾ have reported an electrode for potassium having liquid ionexchanger characteristics. This electrode is based on ion sensitive barrier containing macrocyclic compound, a compound lipid and a mineral oil. The macrocyclic compound being selected from the group consisting of valinomycin, enniatin B, dicyclohexyl-18-crown-6, cyclohexyl-15-crown 5, gramicidin and monactin series, and examples of suitable compound lipids are phosphatides or phospholipids. The lipid is present in sufficient amount to render the barrier substantially solid.

Walker⁽²²¹⁾ has used the Corning ion exchanging solution in microelectrodes for measuring the intercellular potassium ion activity. In addition to the above, electrodes based on p.v.c. impregnated with liquid ionexchanger have been reported. Davies and co-workers⁽¹⁷²⁾ have incorporated potassium-tetra-(p-chlorophenyl) borate in the membrane, whereas Ryba and Patranek⁽¹⁷⁵⁾ have used dimethyldibenzo-30-crown-10.

The liquid membrane electrodes have been used for potassium measurements and monitoring in biochemical and biomedical applications⁽²²²⁾. The liquid exchange micro electrode has been used for measurement of intracellular potassium⁽²²³⁾. Also valinomycin electrodes have been employed in studies of response characteristics⁽²²⁴⁾ as well as potentiometric titrations of potassium in sea water⁽²²⁵⁾.

Scholer and Simon⁽²²⁶⁾ have reported an ammonium ion selective electrode employing a mixture of nonactin and monactin in tris(2-ethylhexyl) phosphate.

In addition to cation liquid membrane electrodes, some anion selective electrode have also been reported. In such cases^(132,207) the ionexchanger is the salt formed of two ions an anion X^- and a cation ML_X^{+n} , where M is an ion such as Ni^{2+} , Fe^{2+} , Co^{2+} , Cu^{2+} , or Cd^{2+} ,

which is complexed with a large neutral ligand L, n is the charge on metal ion and X being the number of ligands bound to each metal ion, that have been used. Ligands are bathophenanthroline or orthophenanthroline. The metal ion in the complex must have a low rate constant for exchange relative to that of anion. Also the metal ligand complex must be stable in contact with water, i.e. will not hydrolyze or dissociate. Finally the salt of the complex must have high solubility in organic solvent and very low solubility in the aqueous phase.

Orion⁽¹³²⁾ have employed iron(II)-phenanthroline complex $[(C_{12}H_8N_2)_3Fe]^{2+}$, for perchlorate. The electrodes of Ishibashi and Kohara⁽²²⁷⁾ are based on perchlorate salts formed from o-phenanthroline and from other two related chelating agents, and concluded that the quaternary ammonium salts are slightly superior. Sharp has reported liquid ion exchanger electrodes⁽²²⁸⁾ for perchlorate based on N-ethylbenzothiazole-2,2'-azaviolene perchlorate in 1,2-dichlorobenzene or bis(2-chloroethyl)ether, which shows improvement over corresponding solid state form⁽²²⁹⁾.

Moody and Thomas⁽⁴⁾ have pointed out that three commercial electrodes for nitrate have similar specifications. The Corning⁽²⁸⁾ electrode uses tridodecylhexadecylammonium nitrate in n-octyl-2-nitrophenyl ether. The principal interferences are ClO_4^- , I^- , ClO_3^- , and Br^- . Carlson and Paul⁽²³⁰⁾ have described the use of the Orion-nitrate electrode to determine fluoroborate ions in the absence of nitrate if the liquid membrane after first converting the nitrate form to fluoroborate. Other nitrate electrodes are reported by Russian workers⁽²³¹⁾ and Qureshi and Lindquist⁽²³²⁾; the latter electrode is based on carbon paste. Also an electrode⁽²³³⁾ based on tris(4,7-diphenyl-1,10-phenanthroline)-nickel(II) in p-nitrocymene, has been reported and used for determination of nitrate in tap-water at the level of 8 - 10 p.p.m.

Another class of liquid membrane electrodes has been developed from studies by Ruzicka and Tjell⁽²³⁴⁾. The electrodes are based on a porous conductor such as graphite, which is first hydrophobized with the pure organic solvent (CCl_4 , CHCl_3 , Xylene, benzene etc.) and then mounted into the Teflon tube used as the electrode body. The electrode is then impregnated through vacuum suction, with a solution of metal dithizonate (or dithizone) in the organic solvent with which the carbon rod was originally hydrophobized. The electrodes formed respond to the selected metal ions.

Many other non-commercial liquid ionexchange membrane electrodes have been reported by various workers. Levins⁽²³⁵⁾ has reported an electrode for barium based on a neutral carrier complex. Electrodes for copper(II) are reported by Gordeev and Syrchenkov⁽²³⁶⁾ and Burdin et al⁽²³⁷⁾. The former have employed 2-hydroxy-3-ethyl-5-methyl hexanophenoneoxime(I) with copper in decanol; potassium, zinc, nickel, iron(II) and cadmium do not interfere. Liquid membrane electrodes responsive to amino acids⁽²³⁸⁾ and large onium ions⁽²³⁹⁾ are also described. Lal and Christian⁽²⁴⁰⁾ have made a potentiometric study of liquid membrane electrode for lead. Guilbault and Brignac⁽²⁴¹⁾ have reported an electrode based on heteropoly compounds as the ionexchanger for the phosphate ions. Backstig⁽²⁴²⁾ has made an analytical study of a picrate ion-sensitive liquid membrane electrode. Ishibashi and co-workers⁽²⁴³⁾ have used a basic dye (Crystal Violet) as ionexchanger site for producing aromatic sulphonate-ion selective electrode. Surfactant electrodes based on liquid ionexchangers, responsive to anionic and cationic surfactants have also been reported by Gavach and co-workers^(244,245) as well as by Birch and Clarke⁽²⁴⁶⁻²⁴⁸⁾.

GAS-SENSING ELECTRODES

The need for rapid, accurate and selective measurements of dissolved gases promoted an interest in developing gas electrodes (Figure 5). The commercially available electrodes produced by Orion and E.I.L. are based on the same principle. The two electrodes, i.e. sensing and reference electrodes, and the internal electrolyte are placed in an epoxy inner body and are separated from the sample medium by means of hydrophobic membrane which is permeable to gases but impermeable to the aqueous solutions. The gases liberated by adjustment of sample pH diffuse through the membrane and dissolve in the internal electrolyte. Thus they participate in an equilibrium involving an ion which can be directly measured by an ion-selective electrode placed within the gas electrode body. For example, if the sensing ion indicated is H^+ , then it is a pH electrode which is used as a sensor in the gas electrode. For other species like hydrogen cyanide, hydrogen fluoride and chlorine, the respective gas electrodes prepared, use a silver sulphide, lanthanum fluoride and silver chloride electrodes as sensors. The response of the electrodes to respective species is essentially Nernstian and is a direct measure of those species. In case of acidic or alkaline gases the potential of the electrode sensing element varies in a Nernstian manner with changes in hydrogen ion level. Whereas in case of other electrodes, like hydrogen cyanide electrode, a silver sulphide electrode used senses the activity of silver ions in equilibrium with cyanide complex in the internal electrolyte⁽²⁴⁹⁾.

Various materials have been suggested as gas permeable membranes, which comprises of two groups. First group⁽²⁴⁹⁾ includes homogenous plastic films in which the diffusing molecule crosses the membrane by first dissolving in the membrane phase; the examples are Teflon,

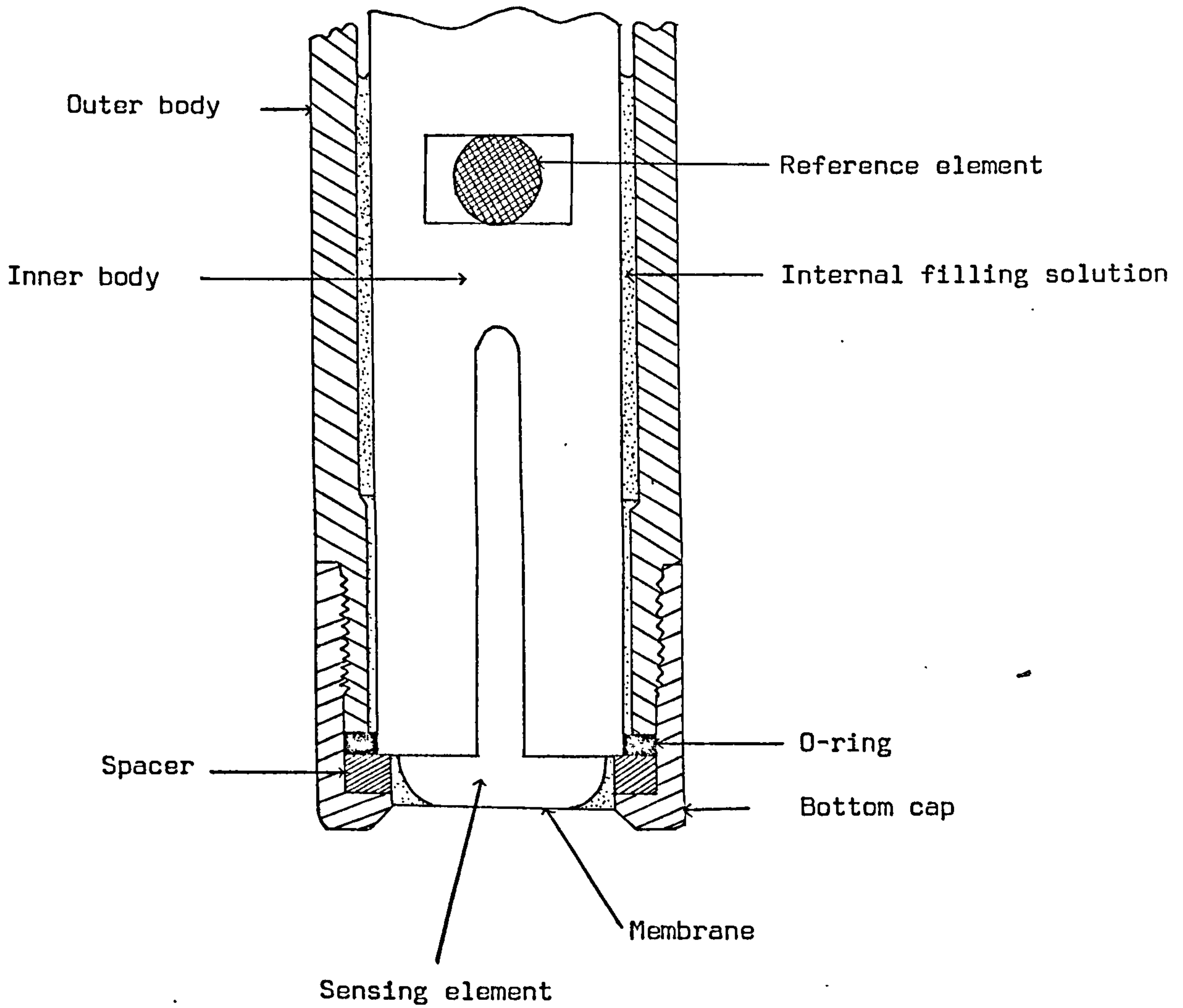

Construction of Gas-sensing electrode

Figure (5)

silicone rubber and Mylar. The second group^(249,250) comprises of heterogeneous microporous membranes, which include a variety of materials like cellulose acetate, Teflon, polyvinylchloride, polyvinylfluoride, polypropylene, polyethylene and most recently polyvinylidene fluoride (which have been used for both E.I.L. and the Orion ammonium electrode). These membranes are not wetted by contact with an aqueous phase and are referred to as air gap membranes, because the species diffuse across an air layer defined by the membrane porous structure. In general, the membrane used should be mechanically strong and should allow a fast passage of gas. Also the recommended pore diameter is less than $1.5 \mu\text{m}$ ⁽²⁵⁰⁾. These conditions, therefore, makes the air gap membrane more suitable for gas sensing electrodes than the homogeneous type of membranes^(249,251). For most diffusing species the permeabilities of air gap membranes are about a thousand times greater than for dense plastic film.

According to Ross and co-workers, with time, the air gap membrane will wet through allowing the sample solution to come in contact with the internal electrolyte. The membrane life in solutions containing wetting agents is considerably shortened. Thus, measurements on blood, serum, milk, beer or effluent water has to be carefully considered, while samples containing organic solvents have to be avoided⁽²⁵⁰⁾. This type of membranes can also be permeable to water vapours, if there is differences between the internal electrolyte and sample solution osmolality, or even differences in sample solution and electrode temperature, as the partial pressure of water vapour depends on temperature.

These electrodes are particularly advantageous in that many species that interfere when conventional ion-selective electrodes are used do not interfere in this case. Moreover difficulties with

reference electrodes and liquid junctions can also be eliminated. Electrodes are unaffected by colour, turbidity and suspended solids. The electrodes can be used for direct, fast and on the spot measurements of gases in chemical processes in the field or plant.

Ionic species such as ammonium, sulphite and bisulphite ions can readily be converted to gaseous species by pH adjustment and can be measured directly as ammonia and sulphur dioxide, using respective electrodes. In such cases adjustment of pH of sample solution, in which the gas measured is present as a dissolved gas, is of great importance. As in case of sulphite and bisulphite to convert completely to sulphur dioxide requires lowering the pH to zero, which is due to low value of pK for sulphurous acid (about 1.9).

The response time of gas electrodes depends on the rate of absorption and desorption of the gas at the solution membrane surfaces. Also it depends on the resistance to diffusion, of the layer formed by the semi-permeable membrane (both the bulk polymer itself and the air gaps) and by the film of the electrolyte on the surface of the sensor. Therefore, the response time depends on the membrane characteristics as well as on the composition of internal electrolyte. In general, response times are faster with increase in level of the gas sensed, and are faster for increasing concentration than for decreasing concentration. Ross et al⁽²⁴⁹⁾ have discussed this in more detail.

The gas electrodes find their use in pollution, industrial and clinical analysis. Also all the standard analytical methods like calibration curves, known addition and subtraction, titrations and Gran's plot, which are associated with ion-selective electrode can be used in case of present electrodes.

The electrode works according to the Nernstian equation. In a

solution⁽²⁵¹⁾ dissolved gas G is in equilibrium with ions A^+ and B^- :

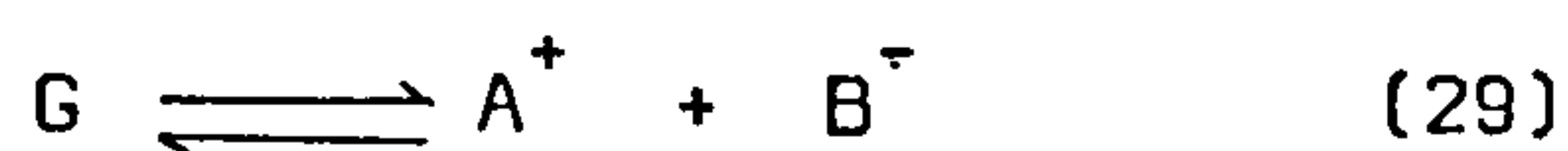

When the electrode is placed in the solution, due to finite vapour pressure of the gas, it permeates the membrane and equilibrium is established when the concentration of G is the same on both sides of the membrane. If there is a specific-ion electrode which senses either A^+ or B^- , one can measure directly the concentration of G in the sample solution by holding constant the concentration of ion not sensed. For example, if the electrode senses the ion A^+ then the internal electrolyte should have a high concentration of the salt M^+B^- . In this case the equilibrium between G, A^+ and B^- requires that:

$$\frac{(A^+)}{(B^-)} = \frac{K (G)}{(B^-)} \quad (30)$$

where K is the dissociation constant and (A^+) , (B^-) and (G) are the concentrations of the respective species. Since (G) is the same in the internal electrolyte and the sample, and (B^-) and K are constants, the electrode potential for the electrode sensing (A^+) as given by the Nernst equation.

$$E = E^0 + 2.303 \frac{RT}{F} \log (A^+)$$

or

$$E = E^0 + 2.303 \frac{RT}{F} \log (G)_{\text{sample}} \quad (31)$$

i.e the gas sensing probe will show a Nernstian response to G. Some possible gas-sensing electrode systems as described by Orion⁽²⁵¹⁾ are given in the following Table.

TABLE (4) Some possible gas-sensing electrode systems

Measured species	Diffusing species (G)	Equilibria in electrolyte	Sensing electrode
NH_3 or NH_4^+	NH_3	$\text{NH}_3 + \text{H}_2\text{O} \rightleftharpoons \text{NH}_4^+ + \text{OH}^-$ $x \text{NH}_3 + \text{M}^{n+} \rightleftharpoons \text{M}(\text{NH}_3)_x^{n+}$	H^+ $\text{M} = \text{Ag}^+, \text{Cd}^{2+}, \text{Cu}^{2+}$
$\text{SO}_2, \text{H}_2\text{SO}_3$ or SO_3^{2-}	SO_2	$\text{SO}_2 + \text{H}_2\text{O} \rightleftharpoons \text{H}^+ + \text{HSO}_3^-$	H^+
NO_2^- or NO_2	$\text{NO}_2 + \text{NO}$	$2\text{NO}_2 + \text{H}_2\text{O} \rightleftharpoons \text{NO}_3^- + \text{NO}_2^- + 2\text{H}^+$	$\text{H}^+, \text{NO}_3^-$
$\text{S}^{2-}, \text{HS}^-, \text{H}_2\text{S}$	H_2S	$\text{H}_2\text{S} + \text{H}_2\text{O} \rightleftharpoons \text{HS}^- + \text{H}^+$	S^{2-}
CN^-, HCN	HCN	$\text{Ag}(\text{CN})_2^- \rightleftharpoons \text{Ag}^+ + 2\text{CN}^-$	Ag
F^-, HF	HF	$\text{HF} \rightleftharpoons \text{H}^+ + \text{F}^-$ $\text{FeF}_x^{2-x} \rightleftharpoons \text{FeF}_y^{3-y} + (x-y)\text{F}^-$	F^- Pt (redox)
HOAC, OAC ⁻	HOAC	$\text{HOAC} \rightleftharpoons \text{H}^+ + \text{OAC}^-$	H^+
$\text{Cl}_2, \text{OCl}^-, \text{Cl}^-$	Cl_2	$\text{Cl}_2 + \text{H}_2\text{O} \rightleftharpoons 2\text{H}^+ + \text{ClO}^- + \text{Cl}^-$	H^+, Cl^-
$\text{CO}_2, \text{CO}_3^{2-}, \text{HCO}_3^-, \text{H}_2\text{CO}_3$	CO_2	$\text{CO}_2 + \text{H}_2\text{O} \rightleftharpoons \text{H}^+ + \text{HCO}_3^-$	H^+
$\text{X}_2, \text{OX}^-, \text{X}^-$	X_2	$\text{X}_2 + \text{H}_2\text{O} \rightleftharpoons 2\text{H}^+ + \text{XO}^- + \text{X}^-$	$\text{X} = \text{I}^-, \text{Br}^-$

Some of the electrodes are briefly described here.

AMMONIA ELECTRODE.

The commercial ammonia electrodes developed by Orion^(252,253) (model 95-10) and EIL⁽²⁵⁴⁾ (model 8002-2) consist of a flat pH electrode covered by a gas permeable hydrophobic membrane. Dissolved ammonia in aqueous solution diffuses through the membrane into the electrolyte layer until the partial pressure on both sides of the membrane is the same. At this stage following equilibrium takes place,

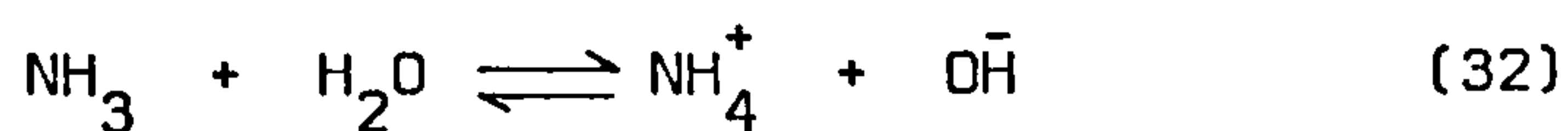

This brings a change in pH of the electrolyte which is measured by the sensing electrode and which is directly proportional to the level of ammonia in the sample, since in any given sample the partial pressure of ammonia will be proportional to its concentration. Thus the electrode potential obeys the Nernst equation, and

$$E = E^0 - 2.303 \frac{RT}{F} \log (\text{NH}_3)$$

The range of true Nernstian slope of the electrode is between $10^0\text{M} - 10^{-6}\text{M}$ ammonia concentration but meaningful measurements can be obtained down to 10^{-7}M concentration. Traditional routine methods for determination of ammonia nitrogen include nesslerization, which is time consuming and involve several steps. Colorimetric methods are also subject to interferences. The electrode method is faster and simpler because time consuming distillation is eliminated. When measuring total ammonia concentration, gases like SO_2 , CO_2 , H_2S and HCN do not interfere at high pH, but interference can be expected from volatile amines. The reproducibility of the electrode as claimed by EIL⁽²⁵⁴⁾ is to $\pm 2\%$.

The Orion instruction manual⁽²⁵²⁾ mentions a variety of applications of ammonia electrodes by different workers for measuring total or free ammonia or ammonium ion concentration. These workers have found comparable results with the automated colorimetric method. The latter

is converted to ammonia by maintaining the pH of the solution at or above 11. The electrode has been employed for total organic nitrogen (after Kjeldahl digestion), the elimination of distillation and titration steps resulted in time savings of 20 to 45 minutes⁽²⁵⁵⁾ and the results showed good agreement with the earlier methods⁽²⁵⁶⁾. Le Blanc and Sliwinski^(45,257) have used the electrode for determination of ammonium nitrogen in waste water from different sources. They have reported a good agreement in results obtained by the direct electrode method, nesslerization and acid titration. River waters, sewage samples, saline waters and different effluents⁽²⁵⁸⁾ have been analysed using ammonia selective electrode and the results are reported to be more precise than those obtained with manual methods and to be comparable to those obtained with automated colorimetric methods. Ammonia electrodes have also been used for the determination of ammonium in soils and clays^(259,260). Woodis and Cummings⁽²⁶¹⁾ have used the electrode for determination of ammonical nitrogen; the results were obtained in about five minutes with no interference from relatively large amounts of urea. Ammoniacal nitrogen recoveries ranged from 99.5 - 101%. The ammonia electrode with 'flow-thru' cap has also been used for direct measurement of ammonia in blood. The electrode has been reported more economical in comparison to Kjeldahl method as it takes lesser time in analysis⁽²⁵³⁾.

SULPHUR DIOXIDE ELECTRODE.

The electrodes manufactured by Orion⁽²⁶²⁾ (Model 95-64) and EIL⁽²⁵⁴⁾ (Model 8010-2) can be used for direct measurements of dissolved sulphur dioxide, sulphite and hydrogen sulphite, by acidifying the sample to convert species to sulphur dioxide:

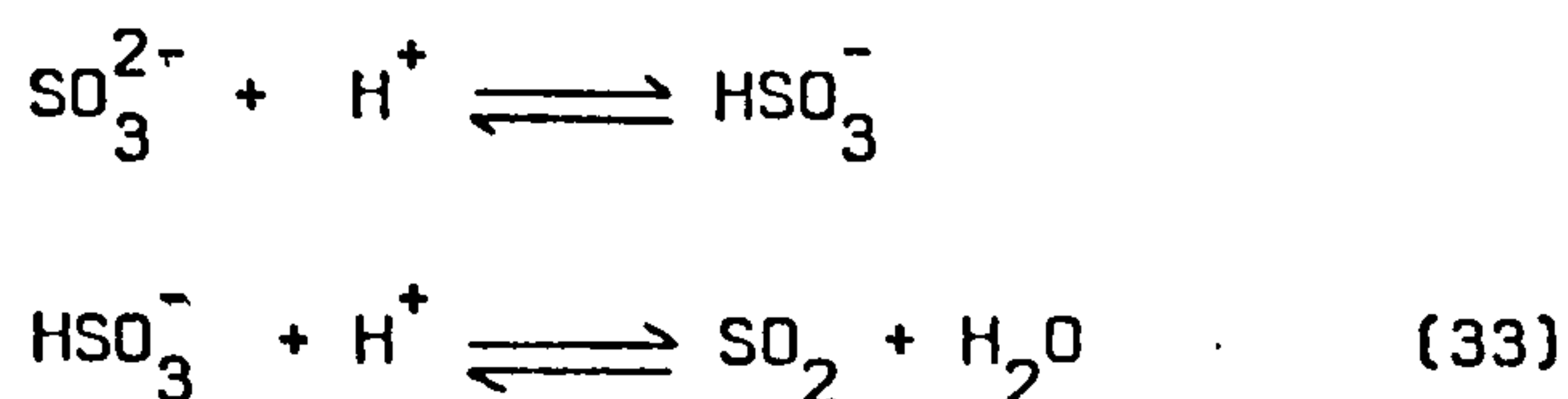

The sulphur dioxide produced diffuses through a hydrophobic membrane. At equilibrium, hydrogen ions are produced by reaction of sulphur dioxide with water, which are measured by the internal sensing electrode. The response produced is Nernstian and is directly proportional

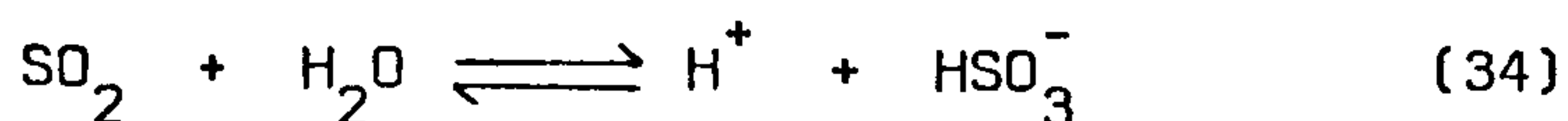

to sulphur dioxide level.

The effective working concentration range of the Orion electrode is reported to be 10^{-6} M to 10^{-2} M, whereas comparable range of EIL electrode is 5×10^{-2} M to 5×10^{-6} M but the response is Nernstian down to 3×10^{-5} M. Electrodes have a fast response time of less than ten seconds down to 10^{-4} M concentration solution but the response time goes up to 3 - 4 minutes at 10^{-6} M.

The use of the electrode simplifies sulphur analysis and eliminates the need of titrations. Moreover colour of the solution, turbidity and suspended solids have no effect on the electrode measurements. This eliminates the requirements of sample distillation and filtration. The main interference is from volatile weak acids like acetic acid and hydrogen fluoride when present in a thirty fold excess over the level of sulphur dioxide. Anions, cations as well as chlorine, carbondioxide and NO_2 do not interfere. The electrode can be used for estimating sulphur dioxide in flue gases and industrial atmosphere. This eliminates routine colorimetric procedures or the barium thordin titration. In food products like processed meat, beer, yogurt, dehydrated potato and fruit squash, sulphur dioxide can be determined by a steam distillation - titration method, but using the electrode it can be measured directly by blending the dry sample with water and adding acid to it. The electrode can be used to measure the ratio of sulphite and sulphur dioxide levels in sulphite pulping cooking liquor by comparing the total

sulphur dioxide in acidified sample to the sulphur dioxide in the original untreated sample. The electrode can be used in boiler feed water, industrial water and photographic developer.

CARBON DIOXIDE ELECTRODES.

An electrode used for direct measurement of carbon dioxide level in the sample was developed by Stow⁽²⁶³⁾ and was modified by Severinghaus⁽²⁶⁴⁾. The electrode incorporates a glass pH sensing electrode and a mildly buffered aqueous solution of potassium chloride and sodium bicarbonate as internal electrolyte. The sensitive tip of pH glass electrode membrane is covered directly with a woven material to form a localised reaction site. The end section of the carbon dioxide electrode is then covered with a thin semi-permeable membrane. The gas from the sample diffuses through this membrane and comes in contact with the electrolyte impregnated spacer. The carbon dioxide present forms carbonic acid and eventually dissociates into hydrogen ion and bicarbonate ion:

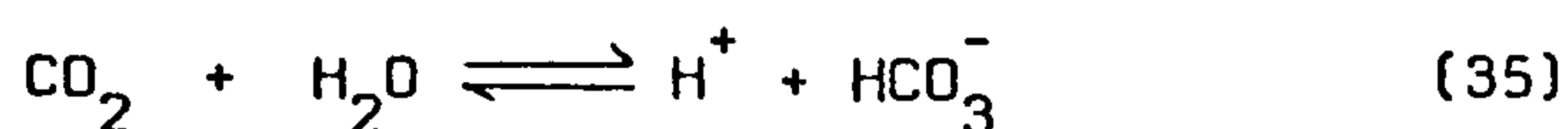

The process is reversible and after the partial pressure is equilibrated on both sides of the membrane, the change in pH caused by the hydrogen ions released, is proportional to the pressure of CO_2 , to which the electrode is being exposed. This in turn corresponds to the CO_2 level present in the sample. Thus the electrode potential varies with the change in carbon dioxide concentration⁽²⁴⁹⁾. The response of the electrode to carbon dioxide is essentially Nernstian and is a source of direct measure of carbon dioxide level from a calibrated graph. Unlike the oxygen electrode, there is no consumption of carbon dioxide from the sample, except for a brief period of equilibrium established; and the

electrode calibration is independent of rates of stirring and membrane thickness. The electrode has mainly been used for biological measurements^(264,265). The electrode is inexpensive, quick, easy and accurate to use.

Recently Ruzicka and Hansen⁽²⁵⁰⁾ have reported a gas sensor by replacing a gas permeable membrane by an air gap which separates the electrolyte layer from the sample solution. By applying only a thin layer of electrolyte on the surface of an indicator electrode, a very high speed of response is obtained. The life time of the electrode is claimed to increase, as the electrode does not come in direct physical contact with the sample solutions; thus there is no interference from surfactants, particulate matter or organic solvents. The electrolyte layer can be easily renewed or even changed according to the requirements of a particular analysis, so that the same electrode can be used for a variety of gases. The air-gap electrode has been used to determine CO_2 and NH_3 contents of the sample volumes 50 to 150 μl to several mls. The electrode was also used to determine the ammonium ion content in serum and plasma samples, yielding highly satisfactory results. The response time was of the order of 1 to 3 minutes. The possibility of the surface contamination of the electrode can be avoided by means of a surface renewal technique which automatically restores the electrode function. The electrode can be used in studies of certain enzymatic reactions in which ammonia is volatilized. Also it is reported that the reproducibility of the electrode might be sufficient for clinical purposes.

BASIS OF THE PRESENT WORK

Current interest in research in the field of ion-selective electrodes lies mainly in the development of new electrodes for a variety of ions and in their applications, particularly as potentiometric analysis is comparatively simple, inexpensive, and readily automated.

The present work on ion-selective electrodes was the first work carried out in this department in this field. It was originally intended to study applications of commercially available ion-selective electrodes. The first study was of the reaction between nitroprusside and sulphide ions (the Gmelin reaction) using a sulphide ion-selective electrode. It was considered that this reaction would prove useful for the quantitative determination of nitroprusside and of sulphide if optimum conditions could be developed for stabilising the coloured complex formed in the reaction.

The main work has been on the development of new electrodes. Studies have been made on the development^{of} heterogeneous membrane electrodes, including the use of potassium zinc ferrocyanide and surfactants as sensing materials in membrane preparations, which can be used for determinations of alkali metals and surfactants respectively.

Most of the effort was directed to the development of new water-insoluble compounds for use in liquid state ion-selective electrodes. For this purpose a novel type of electrode body was developed incorporating a new inert membrane material. These studies were mainly based on water-insoluble basic dye salts, as expertise in the field of extractive photometric method had already been acquired.

Electrodes developed include those for the determination of

surfactant, potassium, zinc, perchlorate and tetrafluoroborate.

GENERAL DESCRIPTION OF ELECTRODE PREPARATION
AND APPARATUS USED

(A) SILICONE - RUBBER MEMBRANE ELECTRODE

Preparation of the membrane

The membrane was prepared from Silastometer 70 and catalyst Bc (Hopkins and Williams Limited). Appropriate amounts of each were mixed on a watch glass and the required amount of ion sensing material (i.e. precipitates or ion-exchangers) was stirred in thoroughly. The resulting mixture was then pressed between two clean and unscratched Perspex plates, separated by means of a thin card, 0.035 cm apart; a heavy weight (4-5 kg.) was placed on the top of the plates and the system left to cure. After about 24 hours, the silicone rubber membrane had cured. It was then peeled off the Perspex plate and used for electrode preparation.

Assembling the electrode

A high-resistance lead glass tube of 1.3 cm diameter was used for the electrode body. Before use, the glass tube was carefully washed, dried at 100°C and then treated whilst still hot with a silanizing agent (Repelcote, Hopkins and Williams Limited). This treatment improved the stability of the signal obtained from the electrodes when in use. A circular disc of 1.3 cm diameter was cut from the prepared membrane and was attached to the base of the glass tube, using self-curing silicone sealant (RTV - 108, Translucent adhesive Sealant, General Electric Corp. New York) as adhesive. The bond was left to cure for 24 hours at room temperature. A silver-silver chloride electrode in contact with an inner reference solution was used as the internal reference electrode. The silver wire was soldered to the inner wire of a coaxial cable connected to the pH meter;

it was not found necessary to screen the electrode further. A suba-seal cap was used to cover the top of the glass tube and to position the internal reference electrode. A complete membrane electrode is shown in figure 6.

Preparation of silver-silver chloride electrode

The electrode was prepared from silver wire of 36 s.w.g. After cleaning the wire with a very fine emery paper, it was dipped in 1:1 nitric acid until effervescence occurred and finally washed with water. The cleaned wire was then dipped in a solution of 0.1 M analytical reagent grade hydrochloric acid solution prepared in tridistilled water. The wire was connected to the anode of the power pack (Twin stabilised D.C. supply Type P.P.3) while a platinum electrode was used as a cathode. A current of 2.5 mA/sq.cm of the surface area was passed for about 30 minutes.⁽²⁶⁶⁾ This produced an even purple-tinted layer of silver chloride on silver wire.

(B) P.V.C. - MEMBRANE ELECTRODE

Casting of the membrane

P.V.C. (Polyvinyl-chloride) membranes were prepared according to the method described by Moody, Oke and Thomas⁽⁸⁾. 0.4 g of potassium zinc ferrocyanide mixed with a solution containing an appropriate amount of P.V.C. powder dissolved in analytical reagent grade tetrahydrofuran, was poured into a 33 mm i.d glass ring resting on a sheet of glass plate. The glass ring was covered by a pad of filter paper; a heavy weight was placed over it and the assembly left for 48 hours to allow a slow solvent evaporation. The resulting membranes were tough and flexible in nature.

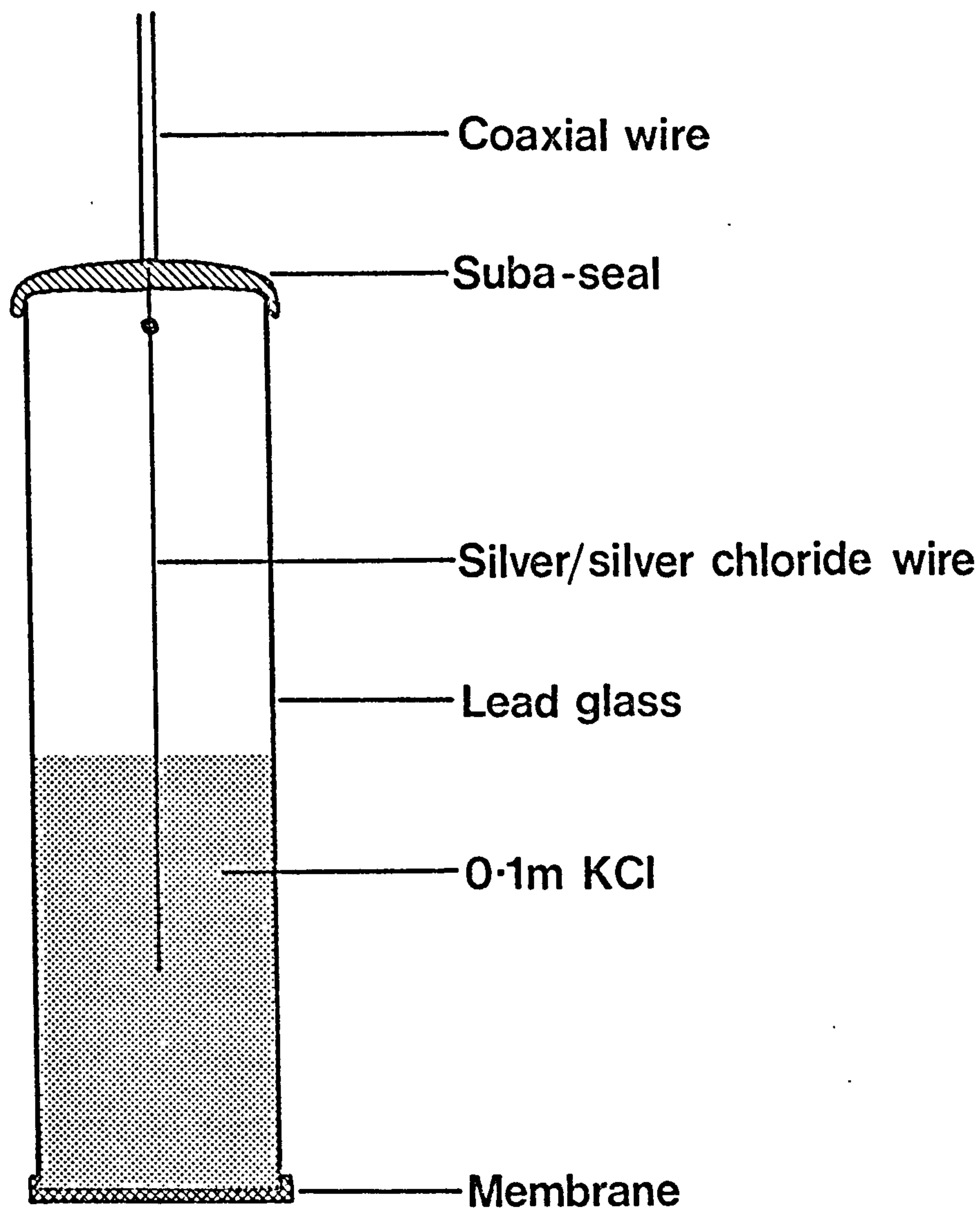

Silicone-rubber membrane electrode

Figure (6)

Preparation of the electrode

The electrode was prepared as follows: A circular disc of 1.3 cm diameter was cut from the prepared membrane and was attached to the end of p.v.c. tube using a solution of p.v.c powder in tetrahydrofuran as adhesive. P.V.C. tube was fitted tightly to one end of the high resistance lead glass tube which has been washed, dried and treated with silanizing agent as before. A silver-silver chloride electrode prepared according to the method already described, was used as internal reference electrode dipped in an appropriate inner reference solution, as it varies for different electrodes. The rest of the construction was completed as described for the silicone-rubber membrane electrode.

As a routine procedure, both silicone rubber and p.v.c. membranes were conditioned before use, by soaking the electrodes for at least 24 hours in solutions of 10^{-3} - 10^{-4} M of the ion to be measured.

(C) LIQUID-STATE ELECTRODE

The electrode was fabricated from P.T.F.E. tube ($\frac{1}{2}$ " internal and $1\frac{1}{4}$ " external diameter). A $\frac{3}{4}$ " section was cut from the end of the tube and threads were cut into two parts so that they can be screwed together and hold a rubber membrane of $\frac{3}{4}$ " diameter. Electrical contact with the back of the membrane was made with an $\frac{1}{2}$ " diameter carbon rod which just fitted the tube and which was held firmly in place by narrow nylon screw passing through the main body of the electrode. Contact with pH-meter was made through a coaxial cable connected to the carbon rod by means of a conducting thermo-setting silver resin preparation (Johnson Matthey Metals Limited).

A commercial natural rubber (Harborough Rubber Company) 2.70 mm in thickness was used for membrane purpose. The rubber membrane was soaked in an organic solution of a basic dye salt till it became

saturated and dye salt was evenly distributed in the rubber matrix. A disc of $\frac{3}{4}$ " diameter was cut and fixed in the electrode. The electrodes were prepared in this way throughout the present study of developments of liquid state electrodes. The complete electrode is shown in figure 7.

(D) SET UP OF ELECTRO-CHEMICAL CELLS

Ion-selective electrodes prepared, were employed for potentiometric studies using an expanded scale PYE 290 pH meter, an Orion double junction (model 90-02) electrode was used as reference. The outer chamber of this electrode was filled with an appropriate aqueous salt solution, the nature of which depending upon the sample solution. The temperature of the cell was maintained at 25°C during the entire work, using a flow-through jacketed beaker, a small water pump and thermostatically controlled water bath. This system controlled the temperature of the solution in the beaker to within $\pm 0.2^{\circ}\text{C}$. An electro magnetic stirrer was used for stirring purpose.

Electrochemical cell may be shown diagrammatically as:

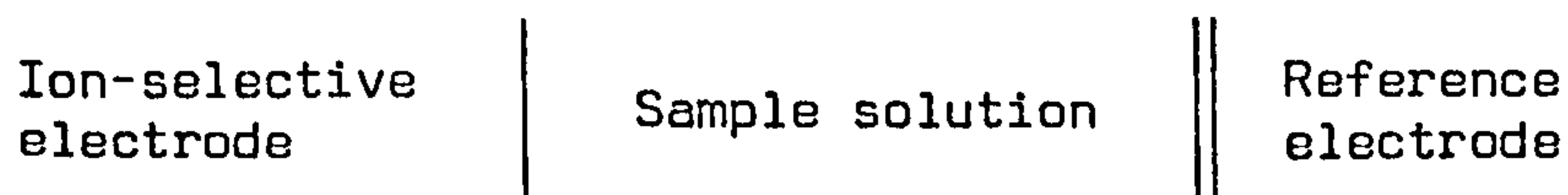

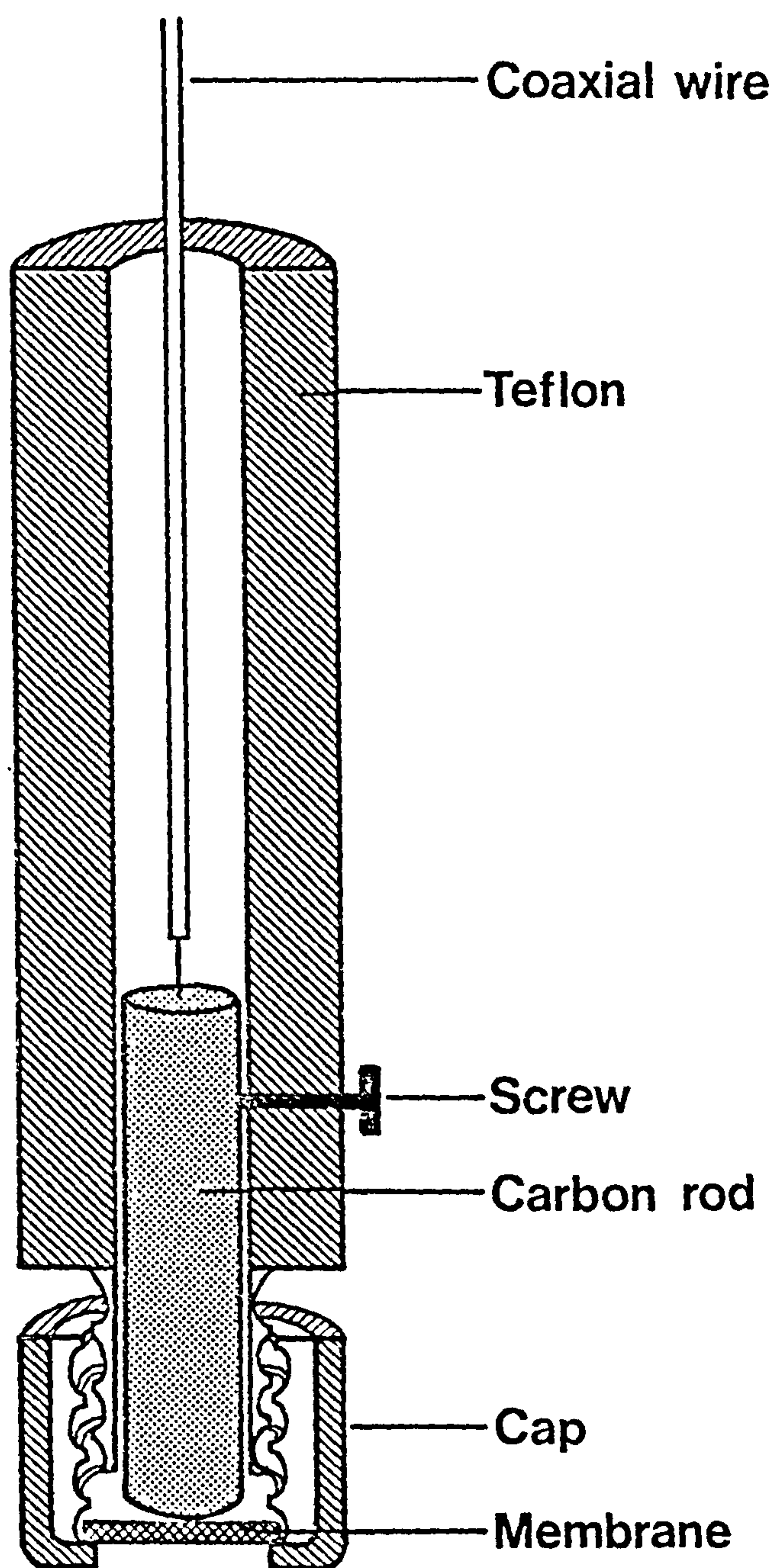

Natural-rubber membrane liquid-state electrode

Figure (7)

SURFACTANT ION-SELECTIVE ELECTRODE

INTRODUCTION

(A) Classification and definition of surfactants

Surface active agents (surfactants) which are essential constituents of detergents have molecular structures which are essentially linear; one end is composed of a group of atoms which are hydrophilic in nature and other end is hydrophobic in nature. The hydrophilic group is usually, although not always, added synthetically to the hydrophobic material in order to produce a compound which is soluble in water. In some cases, in order to increase the solubility or to modify the surface activity of the surfactant, a third component such as ethers, esters or amides, may be introduced as a linking group; a linking is not present in all surfactants. As an illustration, (267) consider the material dodecane, $C_{12}H_{26}$. This is completely insoluble in water. If an OH-group is substituted for one of the terminal hydrogen atoms, the new material, $C_{11}H_{23}CH_2OH$ (lauryl alcohol) is still practically insoluble, but a tendency to solubility has arisen. Now if lauryl alcohol is sulphated to form $C_{12}H_{25} \cdot O \cdot SO_3H$, the sulphuric ester obtained is miscible in water in all proportions. This material on further neutralization with a caustic alkali certain alkaline earths, or organic amines, becomes completely soluble in water and in this instance forms a very good detergent. When sulphonated dodecane gives dodecane sulphonic acid;

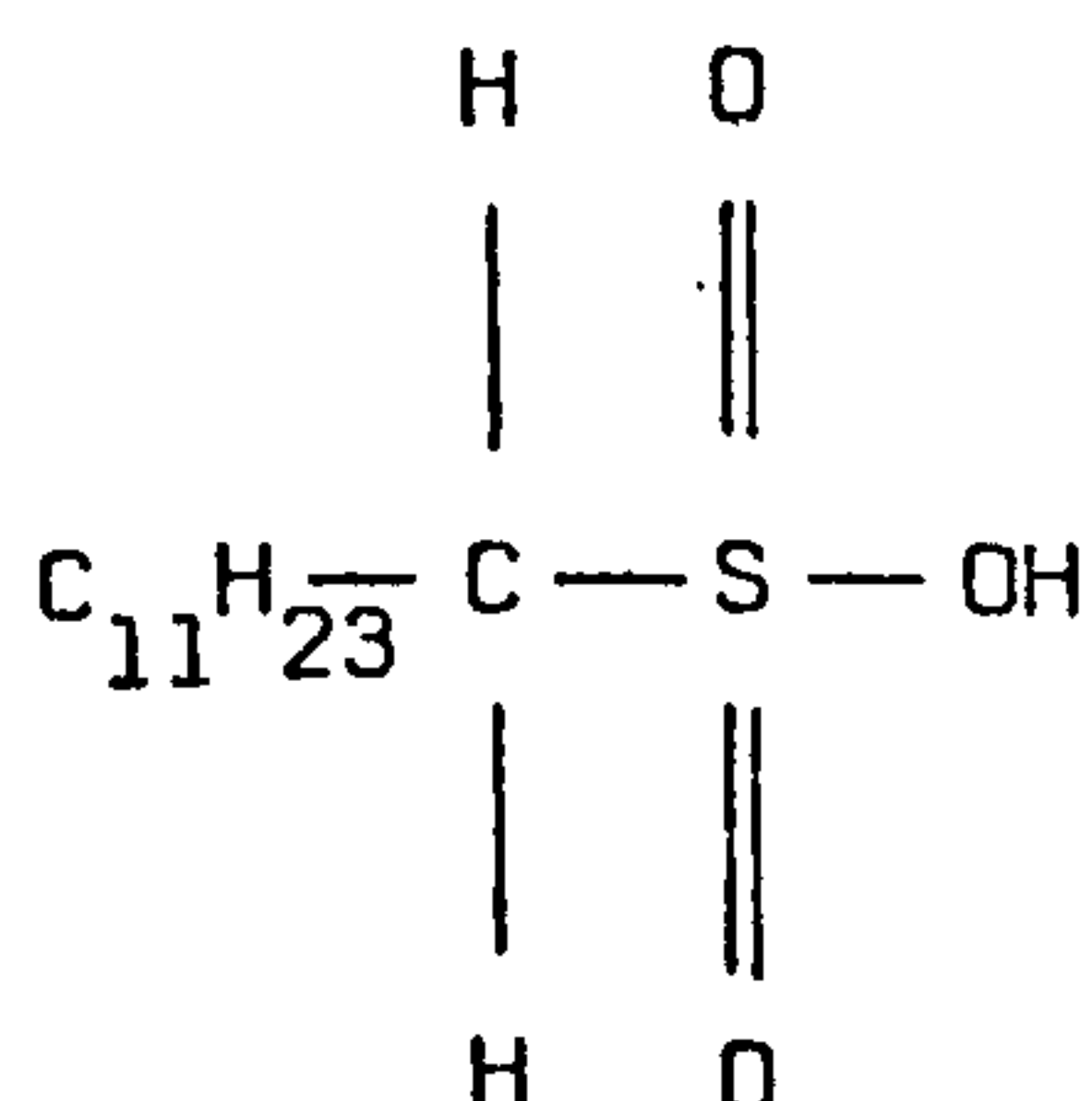

which is miscible with water, and aqueous solutions of salts of this acid are detergents.

Furthermore, if dodecane is chlorinated and then reacted with trimethylamine, lauryl trimethyl ammonium chloride $C_{12}H_{25}(CH_3)_3NCl$ is obtained which again is soluble in water and has some detergent properties.

Classification of surfactants can be based on structural considerations^(267,268) as follows:

Anionic Surfactants: This is the largest group of surfactants containing over sixty sub-classes of anionic surfactants; all except a few are either sulphated or sulphonated products. In these compounds detergency lies in the anions which have to be neutralized with an alkaline or basic materials before full detergent properties are developed.

Cationic Surfactants: In this type the detergency lies in the cation and the compounds are invariably amino-compounds. Quaternary ammonium and quaternary pyridine salts are the most effective members of the group. Some non-nitrogenous surfactants are also included in this group.

Non-ionic Surfactants: These surfactants contain no ionic constituents and are almost always condensation products of ethylene oxide

$\begin{array}{c} H_2C \text{ --- } CH_2 \\ \diagdown \quad \diagup \\ \quad O \end{array}$ with an added hydrophobic group. This hydrophobe is a

high molecular weight material with an active hydrogen atom, e.g. a long chain (fatty) alcohol.

Amphoteric Surfactants: These compounds possess both quaternary ammonium and anionic radicals, the anionic being either a carbonyl, sulphonate or sulphate. Thus they have the characteristics of both anionic detergents and cationic fabric softeners.

(B) Methods of Analysis

Considerable efforts have been made to develop methods for effective determination of these compounds. Simple and quick methods are required which, if necessary, should be capable of operating at or near the production plant, for example, in the case of textile processing where it is desirable to control low concentrations of anion-active material such as sodium alkylsulphates and cation-active compounds such as alkyl pyridinium bromides⁽²⁶⁹⁾. The results of much work on qualitative as well as quantitative determination of surfactants is available in the literature. Quantitative methods⁽²⁶⁸⁻²⁷³⁾ include those based on colorimetric titrations, gravimetric analysis and potentiometric procedures.

Recently liquid ion-exchange electrodes responsive to ionic surfactants have been developed by Gavach et al^(244,245) and by Birch and Clarke⁽²⁴⁶⁻²⁴⁸⁾. These electrodes give Nernstian response over moderate ranges, and should prove successful for direct measurement of surfactant concentrations and in potentiometric titrations⁽²⁴⁵⁾. Cottrell⁽²⁷⁴⁾ has used a coated wire polyvinylchloride electrode for determining very small concentrations of surfactants. In the present attempt to develop similar electrodes, a silicone rubber electrode responsive to cation detergents (hexadecyltrimethylammonium and hexadecylpyridinium ions) has been prepared.

EXPERIMENTAL

Preparation of hexadecyltrimethylammonium dodecylsulphate

The material which is relatively insoluble in water was prepared from hexadecyltrimethylammonium bromide (C T A B) and sodium dodecylsulphate (sodium laurylsulphate). Both materials were obtained from B.D.H. Limited and were used without further purification.

Stoichiometric amounts of both were dissolved in water to obtain 0.5 M solutions. The C T A B: solution was slowly added to sodium laurylsulphate solution with stirring.

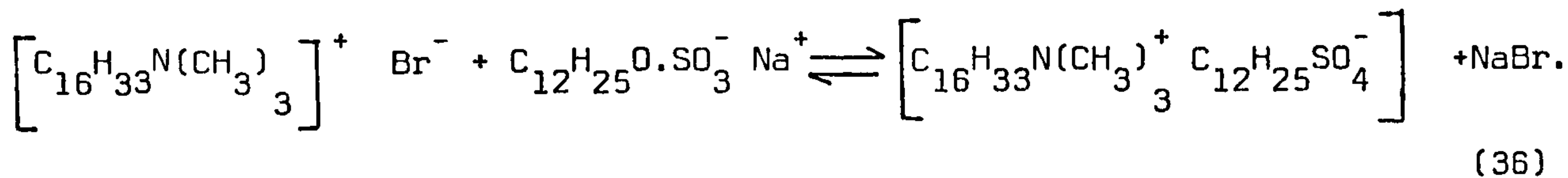

A white gelatinous precipitate was produced which could not be separated from dissolved sodium bromide by simple washing. The material was therefore dialysed in a suitable membrane (Visking tubing, Gallenkamp Limited) for about 48 hours till free from sodium bromide. The material was air dried at 100°C and was ground to pass a B.S. 120 mesh sieve. Further grinding gave particles of maximum 20 μm as indicated by electron microscopy. This material was used to prepare membranes.

Evaluation of the electrode response

The method for preparation of the membrane and the electrode, as well as the electro-chemical cell used was as described earlier (p 72 - 75). The electrode response was constant when 0.1 M potassium chloride solution saturated with silver chloride was used as the inner reference solution. The addition of hexadecyltrimethylammoniumbromide to this solution, to produce a symmetrical environment for the membrane caused the silver chloride to be stripped by detergent action from the silver wire causing an erratic response.

The potential of the cell is given by:

$$E = E^0 + 2.303 \frac{RT}{F} \log a_{A^+}$$

where a^+ represents cetyltrimethylammonium, or cetylpyridinium ions to which the electrode also responds; the linear change in electrode potential was found to be only due to change in log of cationic

surfactant concentrations. Activities were considered to be equal to concentrations, because values of activity coefficients in case of solutions used in the present work was nearly unity.

Electrodes from undialysed and dialysed hexadecyltrimethylammonium dodecylsulphate were prepared and soaked. Electrodes containing between 40 to 60% (w/w) of dialysed material were prepared and examined and electrodes containing 40% (w/w) were found to be the most suitable for subsequent work. A similar electrode prepared from undialysed material was also examined. Solutions of C T.A.B and cetylpyridinium bromide (C.P.B) were prepared in tri-distilled water and used for the study of the electrodes performance. It was not feasible to prepare solutions of concentrations higher than 5×10^{-3} M due to problem produced from micelle formation. The response of the electrodes is shown in Tables 5 and 6 (figure 8).

TABLE (5) Response of the electrode (containing 40% w/w dialysed material) towards cationic detergents.

Concentration (M)	Potential (mV)	
	C T A B	C P B
5×10^{-3}	+8.0	+43.0
10^{-3}	+23.5	+36.0
5×10^{-4}	-5.0	+8.0
10^{-4}	-33.0	-20.0
5×10^{-5}	-60.5	-48.5
10^{-5}	-89.0	-76.5
5×10^{-6}	-80.0	-87.0

TABLE (6) Response of electrodes prepared from dialysed and undialysed precipitates towards C T A B solution

Concentration (M)	Potential (mV)		
	Electrodes containing dialysed material		Electrodes containing undialysed material
	50%	60%	40%
10^{-3}	+50	+62	+95.0
10^{-4}	- 7.0	+79	+63.0
10^{-5}	-64.0	+95	+31.0
5×10^{-6}	-57.0	+104	+16.0
10^{-6}	-	-	+ 4.0

The slight responses obtained with solutions of sodium dodecylsulphate and with sodium tetraphenylboron, ammonium reineckate, potassium hexacyanoferrate(III)(A.R.) and potassium dichromate (A.R.), were in opposite direction to that expected for anions. These changes given in Table 7 were later shown to be due to the cations.

TABLE (7)

Concentration (M)	Potential (mV)				
	Sodium lauryl sulphate	Sodium Chloride	Sodium tetra-phenyl boron	Ammonium reineckate	Potassium chloride
10^{-3}	-46.0	-49.0	-50.0	-33.0	-50.0
10^{-4}	-74.5	-68.0	-66.0	-45.0	-72.0
10^{-5}	-77.0	-87.0	-71.0	-50.0	-77.0

Stability of the electrode response

In order to see the effect of age on electrode response, a check was made at various time intervals, the results are recorded in Table 8.

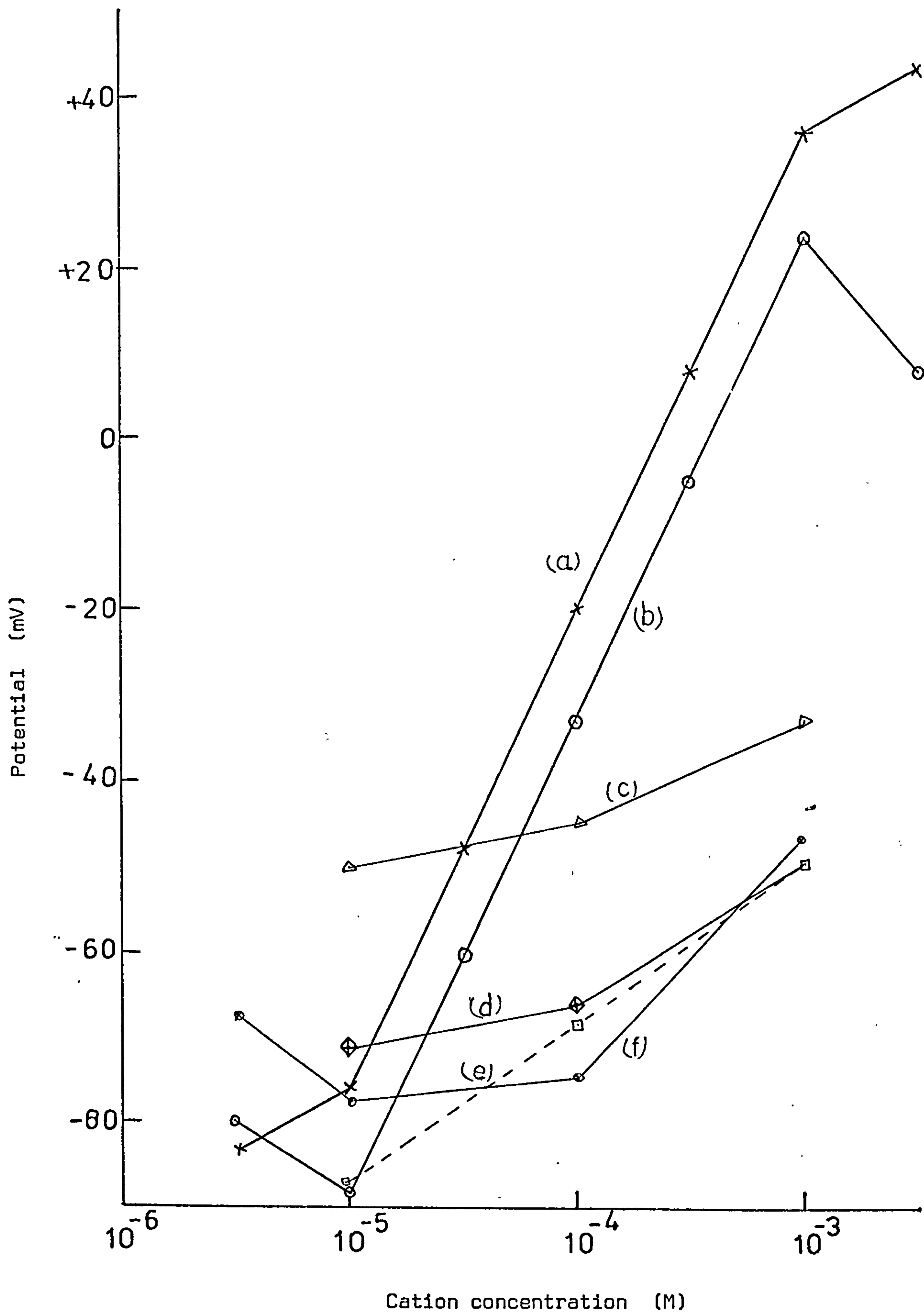

Figure (8)

- (a) Hexadecylpyridinium bromide (b) hexadecyltrimethylammonium bromide
 (c) Ammonium reinekate (d) Sodium tetraphenylboron
 (e) Sodium chloride (f) Sodium dodecylsulphate

TABLE (8) Stability of electrode response.

Time after preparation and soaking (Days)	Potential in 10^{-4} M hexadecyltrimethylammonium chloride (mV)	Potential concentration slope (mV per decade)
0	-33.0	56.0
21	+ 3.0	52.0
54	-16.0	46.0
68	-20.0	44.0

Applications of electrodes in potentiometric titrations.

Solutions (10^{-3} M) of sodium dodecylsulphate, sodium tetraphenylboron, ammonium reineckate, potassium hexacyanoferrate(III)(A.R.) and Potassium dichromate (A.R.) were titrated with 10^{-3} M solutions of hexadecyltrimethylammonium bromide using surfactant selective electrode, to detect the end point. A limited number of titrations were also made with hexadecylpyridinium bromide. The end points in each case were determined by means of first derivative curves and were satisfactorily reproducible.

(A) Potentiometric titration of C T A B and C P B with sodium dodecylsulphate.

The substances were carefully weighed, transferred into 250 ml volumetric flasks and dissolved in tri-distilled water. 25 mls. of cationic surfactant solutions were used against sodium dodecylsulphate as titrant. In the case of reverse titrations 10.0 mls. of sodium dodecylsulphate was taken each time. Potential-volume data for the different titrations are given in Tables 9 and 10 (figures 9 and 10).

TABLE 9

- I Potentiometric titration of hexadecyltrimethylammonium bromide with sodium dodecylsulphate.
- II Potentiometric titration of Hexadecylpyridinium bromide with sodium dodecylsulphate.

I			II		
Amount of titrant added in mls.	Potential E (mV)	$\Delta E/\Delta V$	Amount of titrant added in mls.	Potential E (mV)	$\Delta E/\Delta V$
0	+39.0		0	+47.0	
3	+37.0	0.7	3	+44.0	1.0
6	+34.0	1.0	6	+40.0	1.3
9	+31.0	1.0	9	+34.0	2.0
12	+26.0	1.7	12	+28.0	2.0
15	+19.0	2.3	15	+21.0	2.3
18	+ 9.0	3.3	18	+14.0	2.3
21	- 5.5	4.8	21	+ 3.0	3.7
24	-23.0	5.8	24	-15.0	6.0
24.2	-26.5	17.5	24.2	-20.0	25.0
24.3	-28.5	20.0	24.3	-23.5	35.0
24.4	-31.0	25.0	24.4	-32.5	90.0
24.5	-36.0	50.0	24.5	-35.0	25.0
24.6	-48.0	120.0	24.6	-36.0	10.0
24.7	-50.0	20.0	25.0	-38.5	6.2
24.8	-51.0	10.0	25.5	-40.5	4.0
25.0	-53.0	10.0	26.0	-41.0	1.0
25.5	-54.0	2.0			
26.0	-54.7	1.4			

The observed end point of titration;

I is at 24.6 ml of sodium dodecylsulphate,

II is at 24.4 ml of sodium dodecylsulphate.

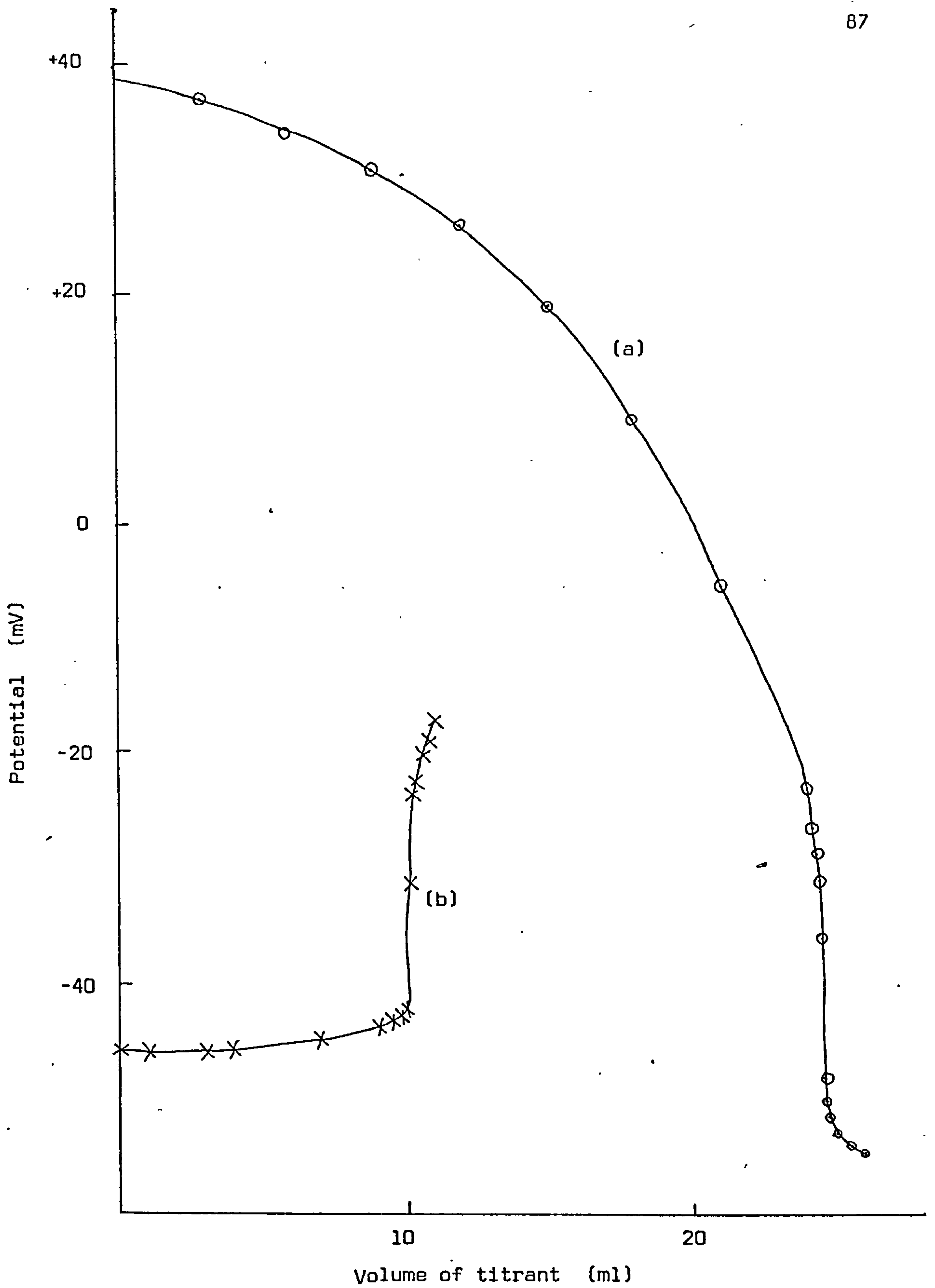

Figure (9)

- (a) Titration of hexadecyltrimethylammonium bromide solution with sodium dodecylsulphate solution.
- (b) Titration of sodium dodecylsulphate solution with hexadecyltrimethylammonium bromide solution.

TABLE (10)

- (I) Potentiometric titration of sodium dodecylsulphate with Hexadecyltrimethylammonium bromide.
- (II) Potentiometric titration of sodium dodecylsulphate with Hexadecylpyridinium bromide.

I		II	
Amount of titrant added in mls.	Potential E (mV)	Amount of titrant added in mls.	Potential E (mV)
0	-45.5	0	-60.0
1.0	-45.5	2	-60.0
3.0	-45.5	4	-60.0
4.0	-45.3	6	-59.5
7.0	-44.5	8	-58.7
9.0	-43.5	9	-58.7
9.2	-43.2	9.2	-58.5
9.5	-42.9	9.4	-58.2
9.8	-42.5	9.6	-58.0
10.0	-42.0	9.8	-58.0
10.1	-31.0	10.0	-57.5
10.2	-23.5	10.1	-50.0
10.4	-22.5	10.2	-46.0
10.6	-20.0	10.4	-45.5
10.8	-19.0	10.6	-44.0
11.0	-17.2	10.8	-43.0
		11.5	-40.0

(I) calculated end point at 10.16 ml of hexadecyltrimethylammonium bromide.

Observed end point at 10.10 ml of hexadecyltrimethylammonium bromide.

(II) calculated end point at 10.2 ml of hexadecylpyridinium bromide.

observed end point at 10.1 ml of hexadecylpyridinium bromide.

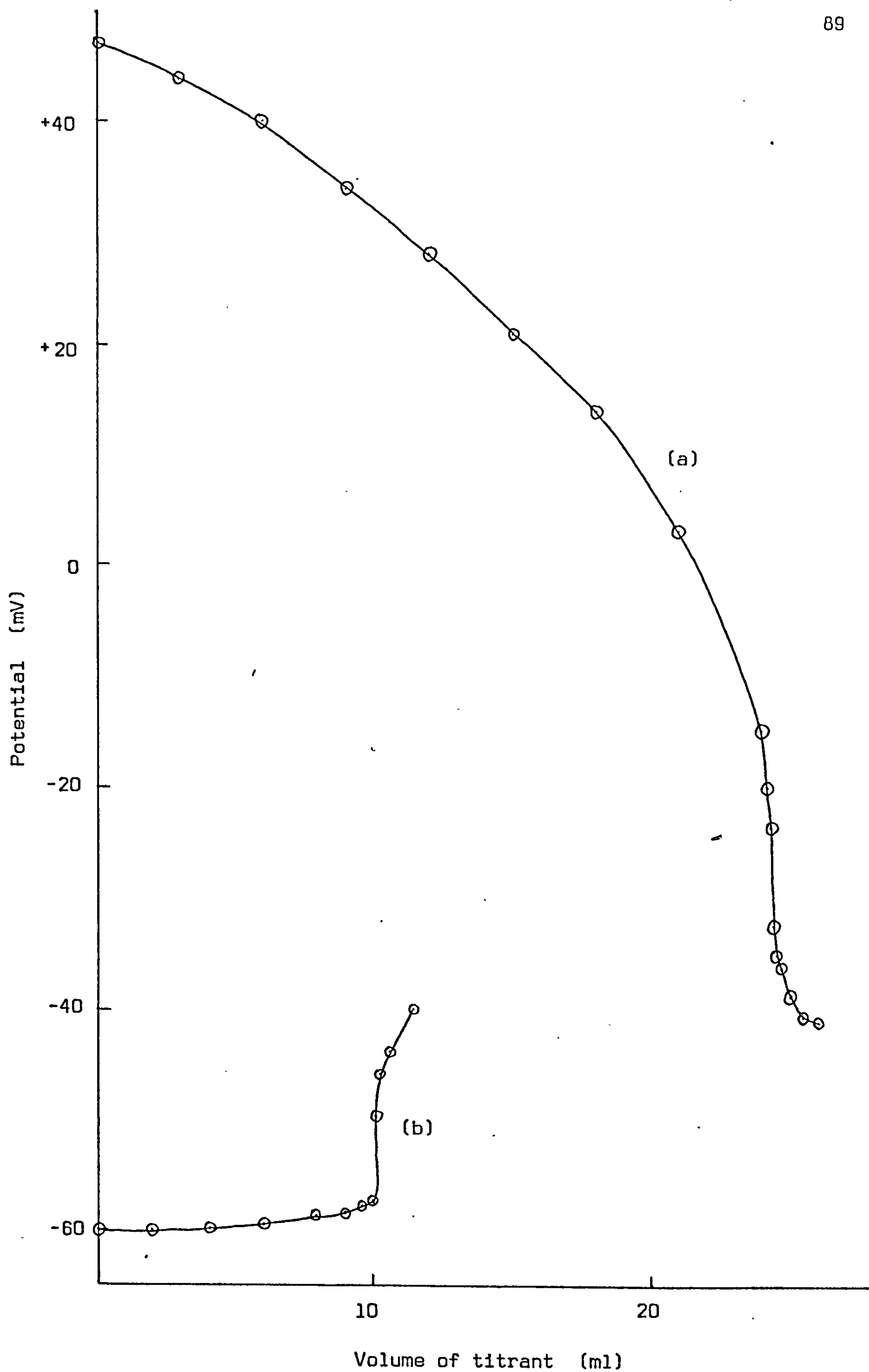

Figure (10)

- Titration of hexadecylpyridinium bromide solution with sodium dodecylsulphate solution.
- Titration of sodium dodecylsulphate solution with hexadecylpyridinium bromide solution.

theoretical values calculated on the basis of molarities already described are 10.1 and 10.7 mls respectively.

This shows that the potentiometric method is more reliable than the colorimetric method, which entirely depends on personal observations and can cause incorrect results.

(B) Use of potassium ferricyanide and potassium dichromate in Potentiometric titration of C T A B

According to the methods reported by Hefferren and Dietz⁽²⁷⁷⁾, Thoma, Ullmann and Loss⁽²⁷⁸⁾, an excess of potassium ferricyanide and potassium dichromate respectively are added to a solution of the quaternary ammonium compounds in a zinc sulphate and acetate buffer. The excess of ferricyanide and dichromate in filtered aliquots are then determined by the standard iodometric method. Successful direct potentiometric titrations of C T A B using potassium ferricyanide $K_3Fe(CN)_6$ and potassium dichromate $K_2Cr_2O_7$ as titrants are possible as shown by the results given in tables 11 and 12 (Figure 11).

TABLE (11) Potentiometric titration of 25 ml of C T A B with potassium ferricyanide

Amount of titrant added ml.	Potential (mV)	Amount of titrant added ml.	Potential (mV)
0.0	+32.0	8.2	-22.0
1.0	+31.0	8.3	-26.0
3.0	+28.8	8.4	-28.0
5.0	+24.5		
6.0	+22.0	9.0	-31.0
7.0	+18.0	9.5	-31.2
7.5	+ 9.0	10.0	-31.0
8.0	- 2.0	11.0	-30.5
8.1	-17.0	12.0	-30.5

Observed end-point is at 8.1 ml of potassium ferricyanide

TABLE (12) Potentiometric titration of 25.0 ml of C T A B with potassium dichromate

Amount of titrant added mls.	Potential (mV)	Amount of titrant added mls.	Potential (mV)
0.0	+33.0	12.2	+ 2.0
1.0	+32.5	12.3	- 1.0
3.0	+31.0	12.35	-14.0
4.0	+30.0	12.4	-15.0
6.0	+27.5	12.8	-15.5
8.0	+21.5	13.0	-15.8
10.0	+14.0	13.5	-16.5
11.0	+11.2	14.0	-17.3
12.0	+ 6.7		

observed end point is at 12.35 ml of potassium dichromate.

(C) Use of ammonium reineckate as a titrant

Wilson⁽²⁷⁹⁾ has described the use of ammonium reineckate

$\text{NH}_4 \left[\text{Cr}(\text{NH}_3)_2 (\text{CNS})_4 \right] \text{H}_2\text{O}$ in the assay of dilute solutions of quaternary ammonium compound, which precipitate as reineckate salts. Though the procedure was successfully used in gravimetric analysis but it is a bit lengthy. C T A B has been determined using the C T A B electrode employing ammonium reineckate as a titrant. Results are shown in Table 13 (figure 11).

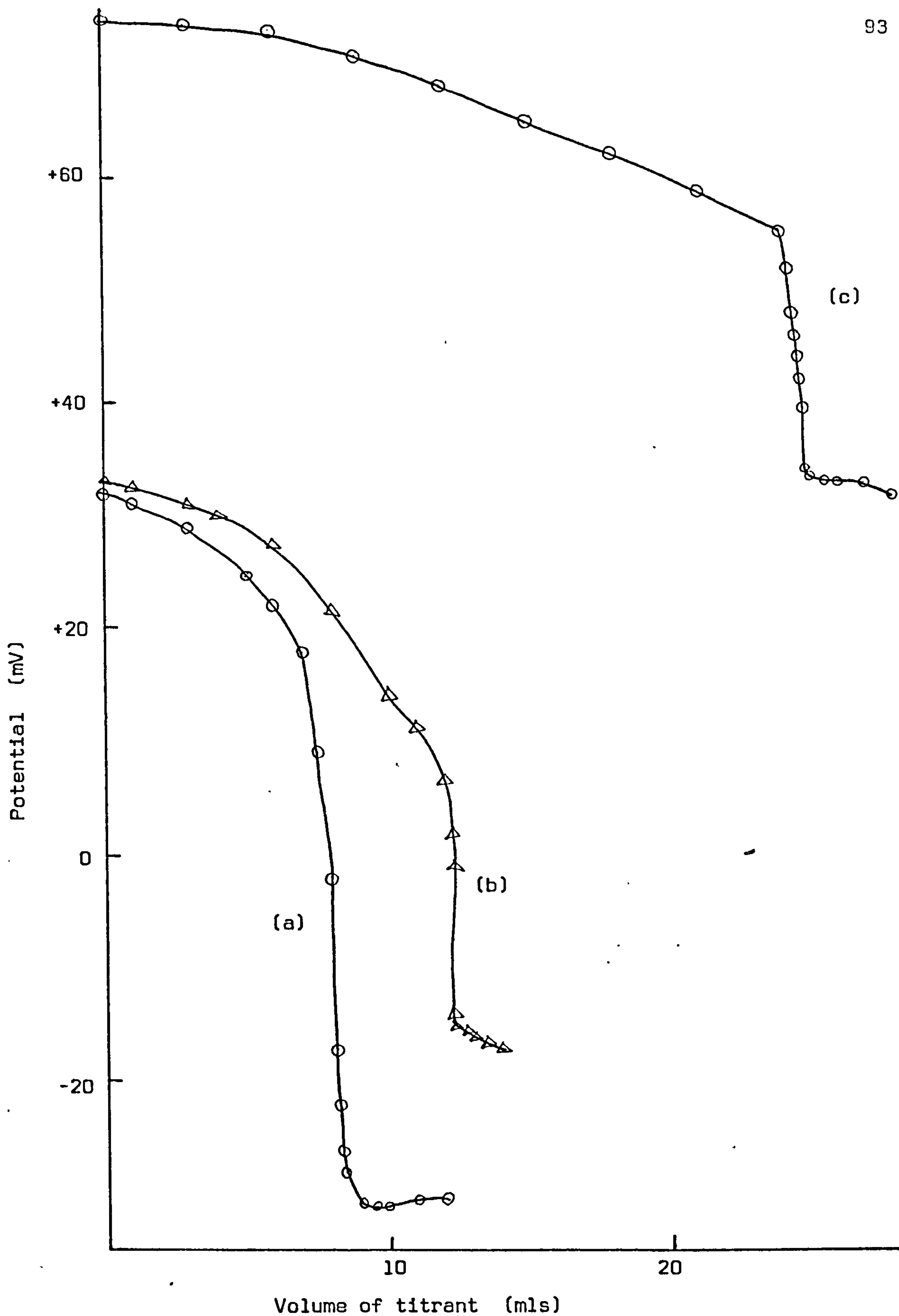

Figure (11)

Titration of hexadecyltrimethylammonium bromide solution with:
 (a) Potassium hexacyanoferrate(III) solution.
 (b) Potassium dichromate solution.
 (c) Ammonium reinekate.

TABLE (13) Potentiometric titration of C T A B with ammonium reineckate.

Amount of titrant added (mls)	Potential (mV)	Amount of titrant added (mls)	Potential (mV)
0.0	+74.0	24.4	+48.0
3.0	+73.6	24.5	+46.0
6.0	+73.0	24.6	+44.0
9.0	+70.6	24.7	+42.0
12.0	+68.3	24.8	+39.5
15.0	+64.8	24.9	+34.0
18.0	+62.0	25.0	+33.8
21.0	+58.8	25.5	+33.2
24.0	+55.0	26.0	+32.8
24.2	+52.0	27.0	+32.8
		28.0	+31.5

The observed end-point is at 24.9 ml of ammonium reineckate.

(D) Potentiometric titration of C T A B with sodium tetraphenylboron.

Uno, Miyajima and Tsukatain⁽²⁸⁰⁾ have reported the use of sodium tetraphenylboron for volumetric determinations of quaternary ammonium compounds. The method was also applied for various salts with long chain alkyl groups which includes C T A B. In their procedure 10 to 20 mls of 0.05 M - 0.001 M sample solution is used, methyl orange indicator is added, the solution is adjusted to pH 3 with HCl and is titrated with 0.05 to 0.02 M standard solution of sodium tetrapheylboron until the acid colour of the indicator appears. In order to avoid this lengthy procedure, an attempt was made to establish a direct titration method using surfactant selective electrode. The results obtained are shown in table 14 (figure 12).

TABLE (14)

(I) Potentiometric titration of C T A B with sodium tetraphenylboron.(II) Potentiometric titration of sodium tetraphenylboron with C T A B

I		II	
Amount of titrant added in mls.	Potential (mV)	Amount of titrant added in mls.	Potential (mV)
0.0	+34.0	0.0	-28.0
3.0	+32.0	3.0	-27.5
6.0	+29.0	6.0	-26.7
9.0	+26.0	9.0	-26.2
12.0	+22.5	12.0	-25.2
15.0	+16.5	15.0	-24.5
18.0	+10.0	18.0	-24.2
21.0	+ 5.0	21.0	-21.0
24.0	- 4.0	23.0	-16.0
24.2	-11.0	24.0	- 6.0
24.4	-16.0	24.2	- 1.5
24.6	-22.0	24.4	+ 3.0
24.7	-26.0	24.6	+ 8.0
24.8	-36.5	24.7	+13.5
24.9	-37.5	24.8	+24.0
25.0	-38.5	24.9	+26.0
25.5	-38.5	25.0	+27.0
26.0	-39.0	25.5	+30.0
		26.0	+32.0
		27.0	+33.0

I The observed end point is at 24.8 ml of sodium tetraphenylborn solution.

II The observed end point is at 24.8 ml of C T A B solution.

II The calculated end point is at 25.05 ml. of C T A B solution.

In potentiometric titration the end point was observed at 24.8 ml of sodium tetraphenylboron against 25 ml. of C T A B As

sodium tetraphenylboron used was of unspecified purity, its molarity was calculated using the molarity of C T A B and was found to be 0.000988 M (titration I, table 14). Using these molarities in potentiometric titration (II), the end-point was calculated to be at 25.05 ml of C T A B whereas experimentally it was observed at 24.8 ml. of C T A B (titration II). Thus the results obtained are fairly in agreement with the theoretical values.

(E) Effect of temperature on the electrode response.

The effect of temperature on electrode performance was studied by measuring the potential in the presence of C T A B at 25, 35 and 45°C, results are shown in table 15 (figure 13).

TABLE (15) Response of the electrode as a function of temperature and concentration.

Concentration (M)	Potential (mV)		
	25°C	35°C	45°C
10 ⁻³	+30.0	+30.0	+31.0
10 ⁻⁴	-26.0	-27.0	-29.0
10 ⁻⁵	-82.0	-84.0	-88.5

DISCUSSION

The heterogeneous solid state electrodes described herein respond only to detergent cations and not to detergent anions. The electrodes based on the membrane containing 40% w/w of dialysed precipitate responded fast, giving a potential concentration slope of 56 mV per/decade change in concentration in the range of 10⁻⁵ to 10⁻³ M of hexadecyltrimethylammonium and hexadecylpyridinium ions (figure 8). Electrodes containing

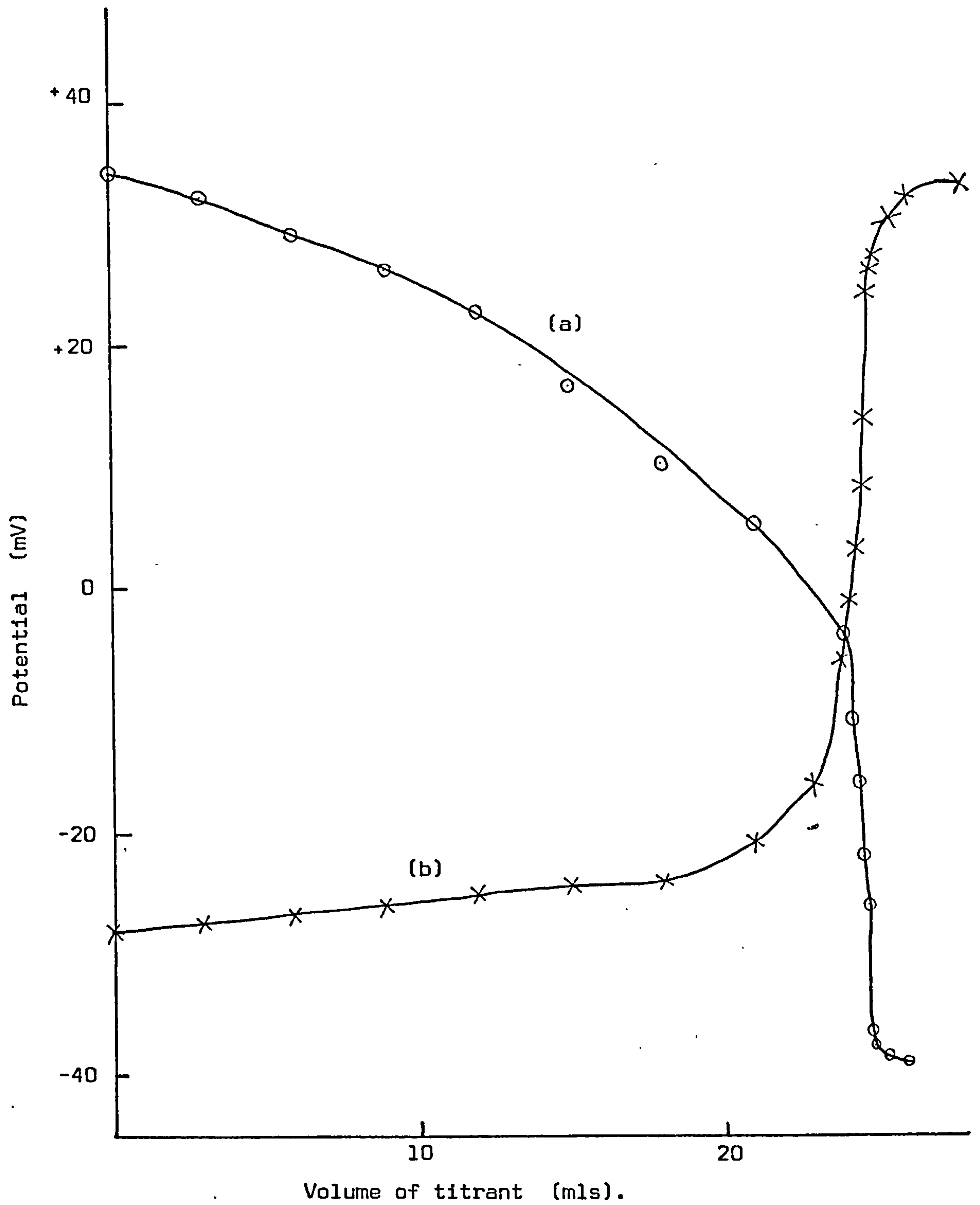

Figure (12)

- (a) Titration of hexadecyltrimethylammonium bromide solution with Sodium tetraphenylboron solution.
- (b) Titration of Sodium tetraphenylboron solution with hexadecyltrimethylammonium bromide solution.

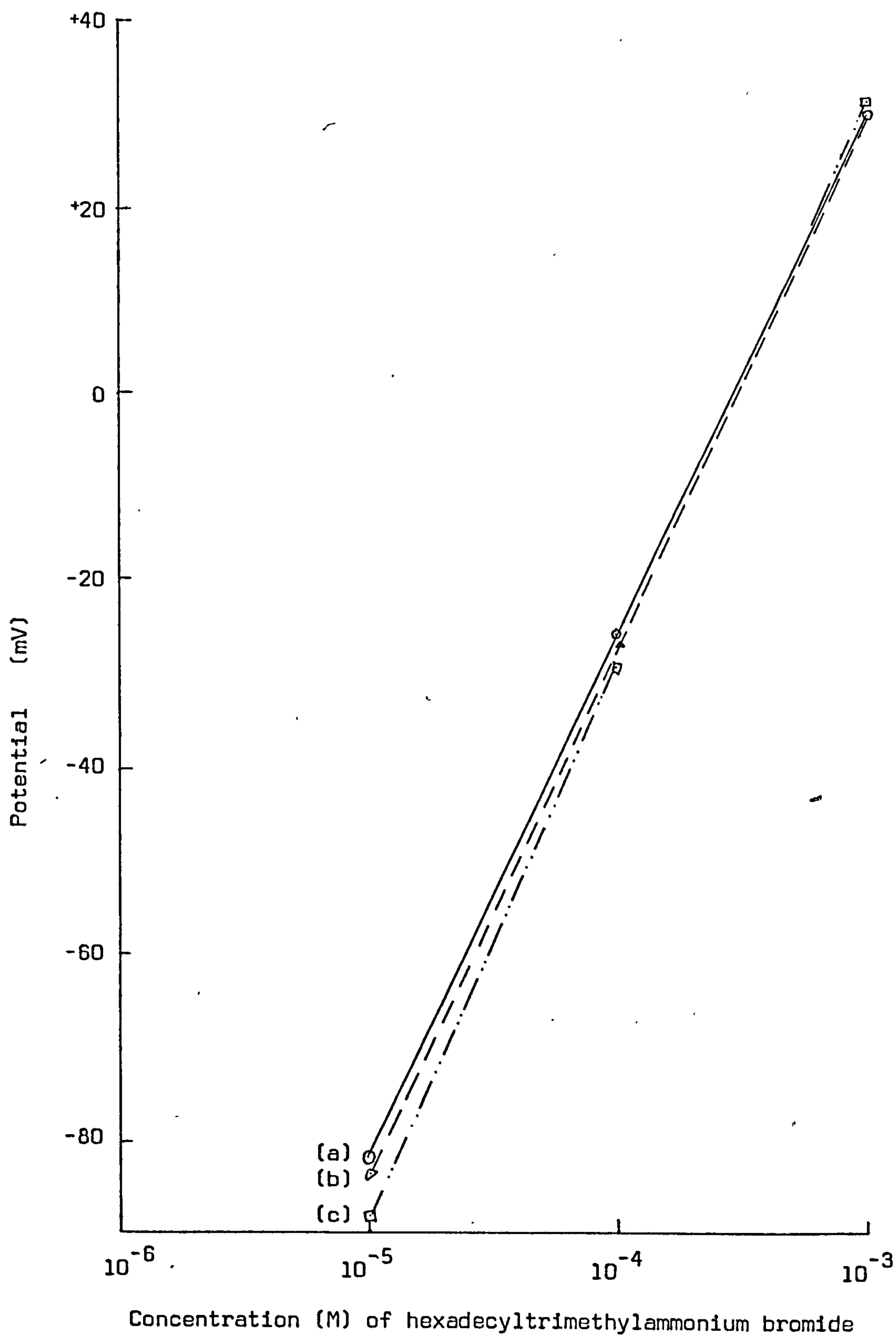

Figure (13)

Effect of temperature on electrode response:

(a) 25°C

(b) 35°C

(c) 45°C

50% (w/w) of the same material gave a response of 57 mV per decade but the time required to obtain a steady potential reading was 10 - 15 minutes at 10^{-4} to 10^{-3} M concentrations and 20 minutes at 10^{-5} M concentration. Electrodes containing 60% w/w surfactant responded even more slowly. Therefore the 40% w/w surfactant electrode was selected for subsequent work. The electrode prepared from undialysed material (40% w/w) also gave a fast response but of only about 32 mV per decade. On immersion in sample solutions, the electrodes responded immediately giving steady potential responses within one minute, the time varied from higher concentration to lower concentration in the range of 10 - 50 seconds respectively.

The electrodes showed a strong memory effect on going from high to low concentrations of cationic surfactants, which was avoided by immersing the electrodes after their use, in solutions of either sodium tetraphenylboron or sodium dodecylsulphate followed by washing with water. The electrodes were then stored in tri-distilled water until required, when they could be used without further treatment.

Although, the potential of electrodes in a particular solution was fairly constant over one or two days. The effect of age on the electrode response recorded between time intervals, during which it was used extensively to detect the end-point in various potentiometric titrations, showed a drift in potential (table 8).

The difference in potential response per decade change in concentration also decreased, falling to 44 mV per decade after two months. These effects might be due to leaching of the active material from the membrane, as the electrodes were stored in water after each use. During the study of electrode response on cationic surfactant solutions at different temperatures, potential concentration slopes of 56, 57 and 60 mV per decade change in concentration were obtained at 25, 35 and 45°C.

The surfactant electrodes have been successfully used for potentiometric titrations of C.T.A.B and hexadecylpyridinium bromide with various titrants. The values of end points obtained are quite near to the theoretical values and are far better than those obtained from colorimetric two phase titrations. The present method is direct and quick as solutions do not need any pre-treatment as already described in other classical methods.

The heterogeneous solid state electrodes in general take longer to prepare than liquid state electrodes. If the present system were to be put into routine use, then a large sheet of the impregnated silicone rubber should be prepared so that the membrane can be replaced readily when this becomes necessary. In the present work excellent results were obtained with a membrane which was soaked and used five weeks after preparation, and there seems to be no reason why longer storage times should be detrimental to these membranes.

POTASSIUM ION SELECTIVE ELECTRODES

Introduction

Many synthetic organic substances have been reported which exhibit ion-exchange properties. Water-insoluble ferrocyanides have become of great importance in studying ion-exchange properties of various metals. These materials behave as cationic and anionic exchangers but the cation exchange capacity is usually high ⁽²⁸¹⁾ and they are very stable to acids and alkalies. The compounds have high ion-exchange affinity for heavy metal ions and have been used to collect traces of caesium ions ⁽²⁸²⁾, as well as several organic compounds ⁽²⁸³⁾.

In mixed ferrocyanides such as those of transition metals, ions of alkali metals occupy the vacancy within the channel in the centre of the cubic structure ⁽²⁸⁴⁾. Zinc ferrocyanide has been used for rapid thin layer chromatographic separation of sodium, potassium, rubidium and caesium ions ⁽²⁸⁵⁾. Copper(II) ferrocyanide exhibits anion exchanger behaviour. The ion-exchange properties of potassium zinc ferrocyanide have been discussed by Pekárek and Vasely ⁽²⁸¹⁾ who report that the ion-exchange mechanism in ferrocyanides seems to be rather complicated and not yet clear, though it can be assumed that the metal ions which are placed in the free space of structural lattice are exchangeable. The present work was undertaken to make an assessment of potassium zinc ferrocyanide $K_2Zn_3 [Fe(CN)_6]_2$ as an alkali metal ion-exchanger in potassium ion-selective electrodes.

The main object of this work was to assess whether potassium zinc ferrocyanide electrode has any advantage compared to glass and other existing electrodes when used for alkali metal ions determinations.

EXPERIMENTAL.

Preparation of the membranes.

Solid potassium zinc ferrocyanide was obtained from British Drug Houses Limited. Before use the material was ground to give a uniformly fine powder. Examination by electron microscopy indicated that the particle size was between 5 to 10 μm ; larger particles were also present owing to flocculation of the fine solid. This material was used for preparation of silicone rubber and p.v.c. membranes. The methods by which electroactive silicone rubber and p.v.c. membranes were prepared is described in detail earlier (P. 72 - 75). In order to get satisfactory electrodes, several membranes of both kinds having different compositions were prepared. In preparation of silicone rubber membranes 50 to 70% (w/w) of potassium zinc ferrocyanide was used. Whereas in case of p.v.c. membranes, several membranes containing 55 to 70% w/w of ion-exchanger were cast.

Evaluation of the electrodes.

A 0.1 M potassium chloride solution saturated with silver chloride was used as the inner reference solution in all the electrodes. Electrodes were conditioned by soaking in 0.1 M potassium chloride solution. The electro-chemical cell used was as described earlier (P. 76). Silicone rubber electrodes containing 50% (w/w) of potassium zinc ferrocyanide produced the desired response of 59 mV per decade. The optimum p.v.c. membranes contained 63.5% (w/w) of potassium zinc ferrocyanide. At least three electrodes of each type (having the same composition) were prepared and tested. The electrode responses in various solutions of alkali-metal ions were measured. In solutions containing potassium ions, both the electrodes responded according to Nernstian equation.

$$E = E^0 + 2.303 \frac{RT}{F} \log a_{K^+}$$

and the potential variations were due to changes in log of potassium ion activities, as potentials at all other interfaces were kept constant. The activity coefficient of the solutions were calculated using an extended form of Deby- Hückel equation⁽²⁸⁶⁾.

$$-\log f = \frac{A z^2 \sqrt{I}}{1 + \sqrt{I}} \quad (39)$$

where f = mean ionic activity coefficient

z = ionic charge of the ion

A = $0.5115 \text{ mole}^{-\frac{1}{2}} \text{ litre}^{\frac{1}{2}}$ at 25°C

I = ionic strength of the solution

During the work, electrodes were used in solutions in ascending order of activities i.e. from low to high ionic activities. The activity values were determined by assuming that the activity coefficient of potassium ion was the same as the mean ionic activity coefficient of potassium chloride.

Electrodes were wiped carefully with paper tissues when changing from one solution to another of the same ionic species. Before using in solutions of different species, electrodes were washed a few times with tri-distilled water. When not in use electrodes were stored in 10^{-4} M potassium chloride solution. All electrodes responded immediately when immersed in sample solutions and response times were within one minute.

Response of Electrodes in potassium ion solutions.

Silicone rubber and p.v.c. membrane electrodes were tested in solutions of 1M to 10^{-5} M activity of potassium ion and the results were given in table 16, figures 14 and 15 respectively.

TABLE (16) Response of different electrodes in potassium ion solutions

Ion activity (M)	Potential (mV)	
	Silicon rubber membrane electrode	P.V.C. membrane electrode
10^0	+99.0	-
10^{-1}	+49.0	+44.0
10^{-2}	-10.0	-15.0
10^{-3}	-69.0	-74.0
5×10^{-4}	-	- 102.0
10^{-4}	-128.0	- 112.0
5×10^{-5}	-156.0	-
10^{-5}	-168.0	-

Response of Interfering ions

The presence of ions other than those to which an electrode is selective, produce an effect on electrode response to varying degrees. In the present work, such effects were evaluated by using chloride salt solutions of lithium, sodium, rubidium, caesium and ammonium, over an activity range of 10^{-1} M to 5×10^{-5} M. The performance of electrodes evaluated is shown in table 17 (figures 14 and 15).

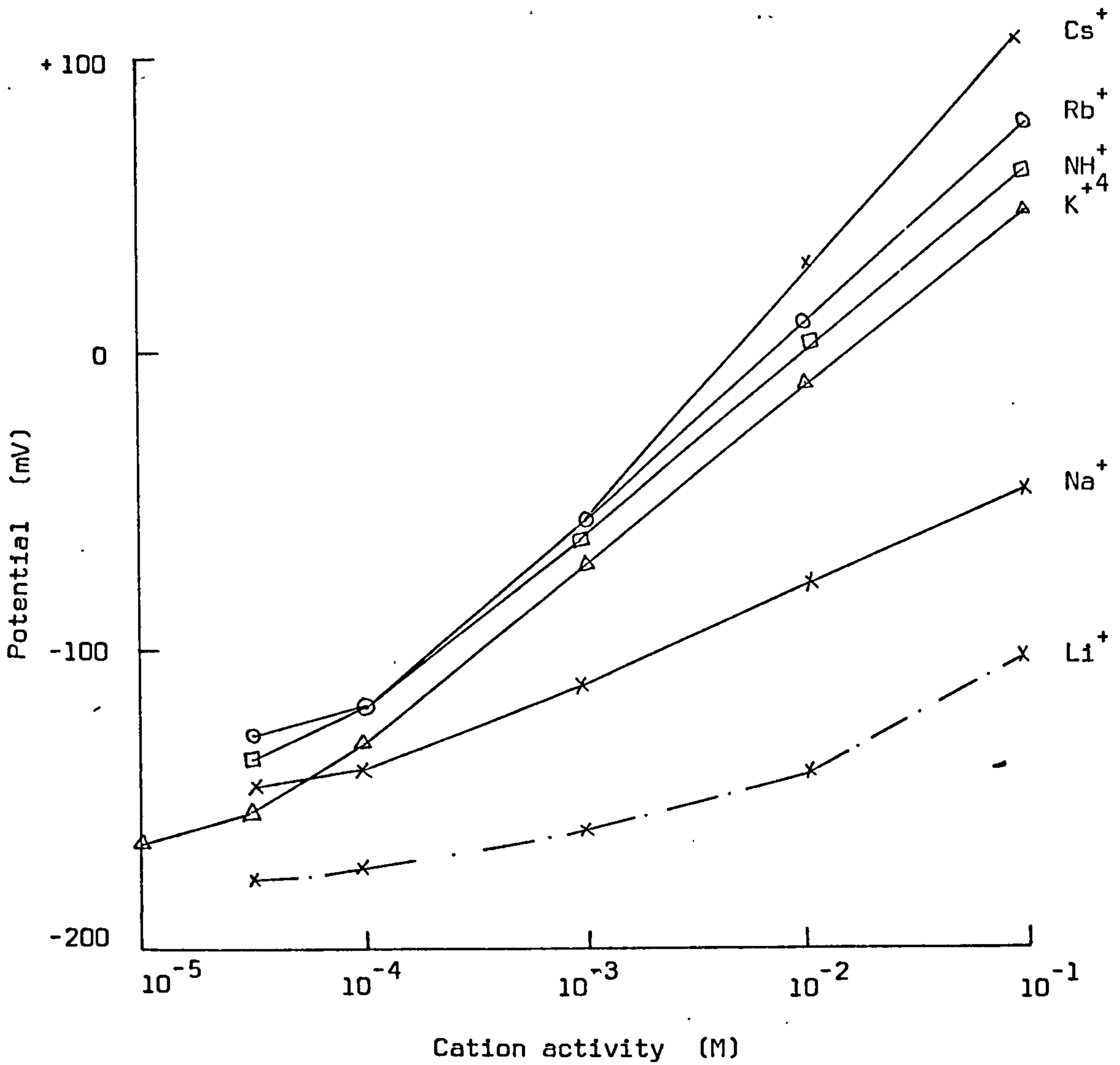

Figure (14)

Response of silicone rubber membrane electrode towards different cations.

TABLE 17 Response of electrodes towards different cations

Ion	Activity	Potential (mV) of electrodes	
		Silicone rubber membranes	P.V.C. Membranes
Li ⁺	10 ⁻¹	-101	-59
	10 ⁻²	-139	-86
	10 ⁻³	-161	-104
	10 ⁻⁴	-172	-130
	5 x 10 ⁻⁵	-176	-138
Na ⁺	10 ⁻¹	-45	-54
	10 ⁻²	-78	-88
	10 ⁻³	-112	-123
	10 ⁻⁴	-142	-153
	5 x 10 ⁻⁵	-146	-158
Rb ⁺	10 ⁻¹	+80	+83
	10 ⁻²	+16	+13
	10 ⁻³	-57	-60
	10 ⁻⁴	-117	-103
	5 x 10 ⁻⁵	-129	-117
Cs ⁺	10 ⁻¹	+107	+108
	10 ⁻²	+ 30	+16
	10 ⁻³	-63	-59
	10 ⁻⁴	-120	-90
	5 x 10 ⁻⁵	-131	-
NH ₄ ⁺	10 ⁻¹	+65	+66
	10 ⁻²	+6	+3
	10 ⁻³	-62	-64
	10 ⁻⁴	-120	-111
	5 x 10 ⁻⁵	-139	-129

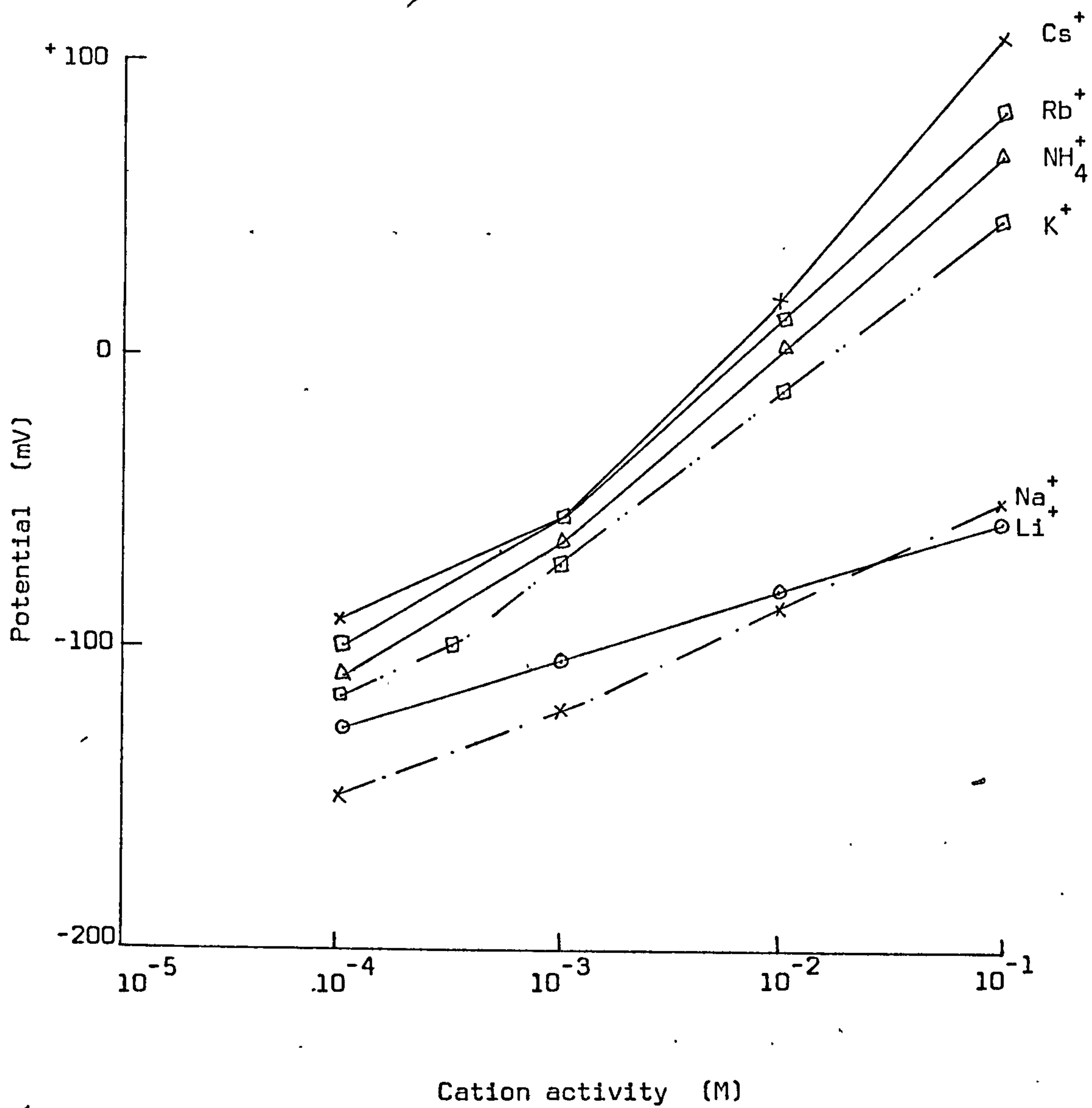

Figure (15)

Response of p.v.c. membrane electrode towards different cations.

Effect of pH on the Electrodes Potential

pH is often one of the most important general factors controlling the efficient and effective working of ion-selective electrodes. Silicone rubber and P.V.C. membrane electrodes were examined in 10^{-1} M and 10^{-2} M solutions respectively. The pH was controlled using dilute hydrochloric acid and sodium hydroxide solutions the potential response shown by the two electrodes is given in Table 18 and shown graphically in figure 16.

TABLE (18) Response of electrodes as a function of pH

pH	Potential (mV)	
	Silicone rubber membrane electrode	P.V.C. membrane electrode
3.0	+49.0	-17.0
4.0	+52.0	-10.0
5.0	+52.0	-10.0
5.5	+52.0	-10.0
6.0	+52.0	-10.0
7.0	+52.0	-10.0
8.0	+52.0	-10.0
9.0	+52.0	-10.0
9.5	+52.0	-10.0
10.0	+54.0	-5.0

Effect of temperature changes

The effect of change in temperatures of potassium chloride solutions on electrode response is given in Table 19 (figure 17).

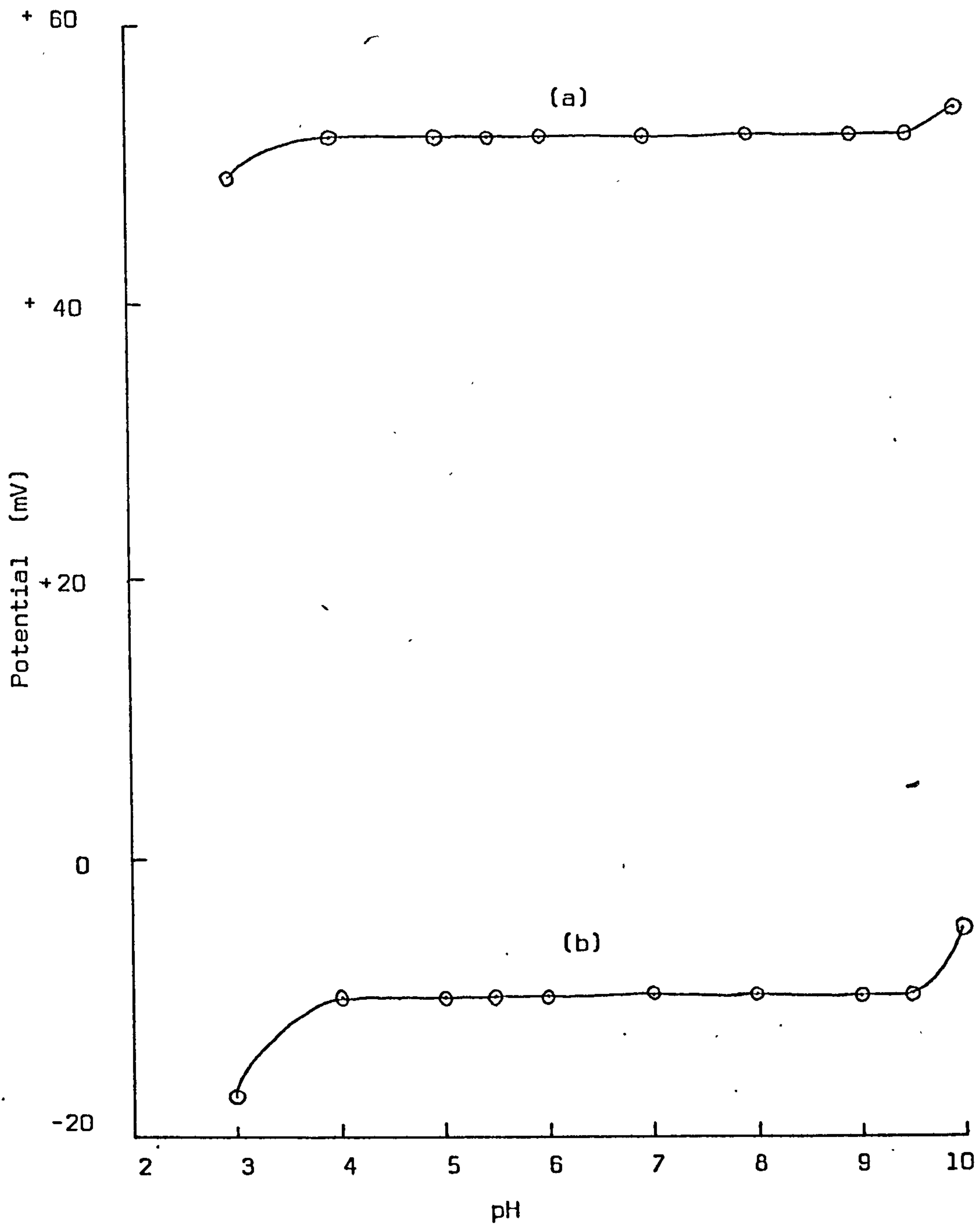

Figure (16)

Response of electrodes as function of potassium chloride solution pH.

(a) Silicone rubber membrane electrode.

(b) P.V.C. membrane electrode.

TABLE (19) Response of silicone rubber membrane electrode in potassium chloride solution at various temperatures.

Ion Activity (M)	Potential (mV)		
	25°C	35°C	45°C
10 ⁻¹	+50.0	+50.0	+52.0
10 ⁻²	-9.0	-11.0	-11.0
10 ⁻³	-68.0	-72.0	-74.0
10 ⁻⁴	-127.0	-133.0	-137.0
5 × 10 ⁻⁵	-156.0	-163.0	-168.0

Calculations of selectivity constants in separate solutions of potassium and other univalent cations.

Selectivity constants are calculated as follows: According to the Nernstian equation, the potential of the potassium selective electrode in solutions containing only potassium ion is given as

$$E_1 = E^0 + 2.303 \frac{RT}{F} \log a_{K^+} \quad (40)$$

where a_{K^+} is the activity of potassium ions.

If any other univalent cation M^+ is also present in the solution of potassium ions, then potential can be given as:

$$E_2 = E^0 + 2.303 \frac{RT}{F} \log (a_{K^+} + K_{K^+M^+} a_{M^+}) \quad (41)$$

when $K =$ selectivity constant.

But in case, the electrode is used in solution containing only ion M^+ , then $a_{K^+} = 0$, and the equation (41) becomes,

$$E_2 = E^0 + 2.303 \frac{RT}{F} \log K_{K^+M^+} + 2.303 \frac{RT}{F} \log a_{M^+} \quad (42)$$

In such cases, at the same activities of potassium and an interfering ion M^+ , the difference in potentials can be determined by subtracting equation (42) from (40), therefore:

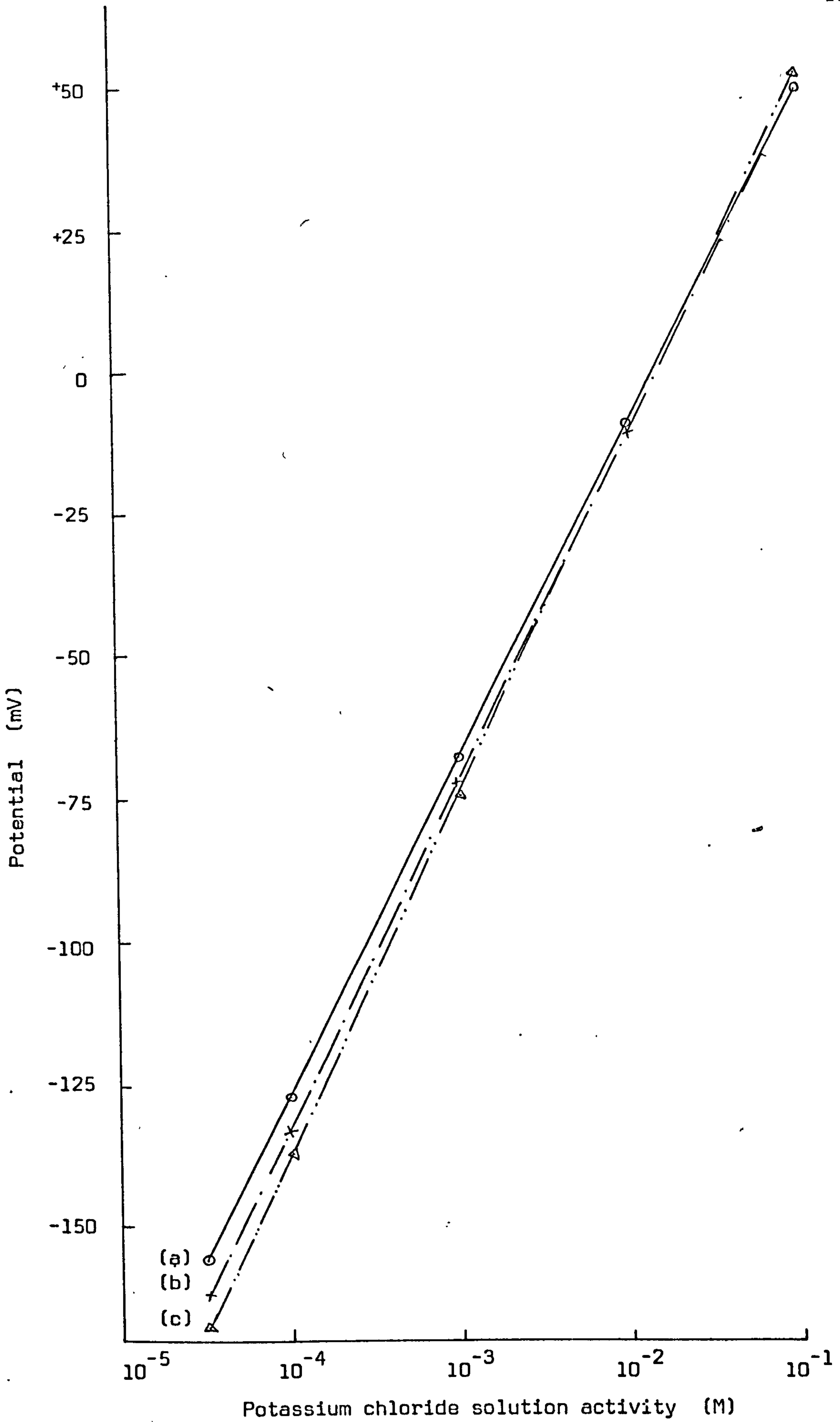

Figure (17)

Response of silicone rubber membrane electrode at various temperatures:

(a) 25°C (b) 35°C (c) 45°C

$$E_1 - E_2 = E^0 + 2.303 \frac{RT}{F} \log a_{K^+} - E^0 - 2.303 \frac{RT}{F} \log K_{K^+/M^+} - 2.303 \frac{RT}{F} \log a_{M^+} \quad (43)$$

At the same activities $a_{K^+} = a_{M^+}$

therefore $E_1 - E_2 = -2.303 \frac{RT}{F} \log K_{K^+/M^+}$

$$\text{or } \log K_{K^+/M^+} = \frac{E_2 - E_1}{2.303 RT/F} \quad (44)$$

The selectivity constants were calculated using the above equation on the basis of potentials measured for single cations in separate solutions of 10^{-1} M activity; the results are given in Table 20.

TABLE 20 Selectivity constants (K_{K^+/M^+}) calculated by comparing potentials in 10^{-1} M solutions.

Ion	Silicone rubber membrane electrode	P.V.C. membrane electrode
Caesium	9.5	11.6
Rubidium	3.3	4.3
Ammonium	1.8	2.2
Sodium	0.025	0.021
Lithium	0.003	0.017

DISCUSSION

The ion-exchange properties of water-insoluble heavy metal ferrocyanide have been studied extensively⁽²⁸¹⁾, but, to our knowledge, no previous attempt has been made to incorporate them into membranes for use in ion-selective electrodes. The present work has shown that potassium zinc ferrocyanide can be used as the ion-exchanger in an alkali metal ion-selective electrode.

The responses of silicone rubber and of p.v.c. membrane electrodes towards different cationic solutions have indicated that a desired

Nernstian slope was obtained due only to change in potassium ion activity over the ranges of 5×10^{-5} M to 10^{-1} M and 5×10^{-4} M to 10^{-1} M solutions respectively. The response time for steady potentials to be achieved varied from 5 to 35 seconds, in the order of decreasing activities of solutions. Silicone rubber electrodes prepared from unground potassium zinc ferrocyanide gave lower response of 50 mV per decade change in ion activity of potassium. Stirring of the solutions did not have any significant effect on electrode responses or on the rate of attainment of steady potentials. The electrodes did not show any significant drift in potential over a period of weeks. In the first month silicone rubber and p.v.c. electrode readings tend to drift by approximately +2 mV from the original potential. After one more month their readings drifted towards the positive direction by 8.0 and 6.0 mV respectively.

The selectivity constants show an interference from other species in the order of caesium > rubidium > ammonium > sodium > lithium. In potassium determinations the main practical interference is from sodium ions. As the selectivity constant of present electrodes indicate a reasonable selectivity of potassium over sodium ions, the electrodes can be used in presence of sodium ions within specified ranges. The selectivity is better than that obtained with potassium ion-selective glass electrodes. Much greater selectivity of course, can be obtained with the valinomycin electrodes.

Selectivity constant $K_{K^+Na^+}$ for,

Valinomycin electrode	7.5×10^{-5}
Glass electrode	0.05 - 0.1
Present electrodes	0.021 - 0.025

During studies of the effect of solution pH on electrode response

a constant potential was obtained in the pH range 4.0 to 9.5. At pH 3.0 lower potentials and at pH 10.0 higher potentials were obtained.

The results of this study of the effect of temperature variations on electrode response, are in agreement with the theoretical values, a slopes of 59, 61 and 63 mV per decade change in activity of potassium ions were obtained at 25, 35 and 45⁰C respectively.

Previous work⁽²⁸³⁾ had shown that certain aromatic amines, including procaine and sulphonamides, are coprecipitated from acidic solutions of potassium zinc ferrocyanide. It was hoped that useful responses would be obtained with the potassium zinc ferrocyanide for protonated forms of these compounds. The selectivity to solutions of procainehydrochloride, however, was similar to that for solutions of sodium and lithium, but the response slope was only in the range of 15 - 20 mV per decade change in activity and further study was discontinued.

THE POTENTIALITIES OF BASIC DYE SALTS FOR USE IN ION-
SELECTIVE ELECTRODES

The potentialities of basic dyes are already well known in the field of colorimetry. These dyes have been widely used for analytical determinations of numerous elements and the subject has been reviewed⁽²⁸⁷⁻²⁸⁹⁾ in some detail. Basic dyes are sensitive reagents for the extractive photometric determination of those anions which form suitable ion-association complexes. Under suitable conditions larger cationic basic dyes form ion pairs with anions containing metals or other elements and can be selectively extracted into an appropriate organic solvent. In the formation of anionic complex of an element which is reactive with respect to particular dye cation, the presence of an appropriate anionic ligand is necessary; selectivity is possible in that one element may react only in the form of chloride complex anion while another as a fluoride complex anion.

These dyes are based on two main groups:

- a. Triphenylmethane dyes
- b. Xanthene dyes

The main difference between these two groups is that the oxygen bridge of the xanthene cations cause them to be more rigid than the triphenylmethane cations and useful in certain cases in fluorimetry. The high molar absorptivities ($0.6 \times 10^4 - 1.2 \times 10^4 \text{ l mol}^{-1} \text{ mm}^{-1}$) obtained make basic dyes very useful in this field and the anions to be determined need not be coloured. The triphenylmethane dyes which are studied here are strongly coloured and have great affinity for anions forming cationic-anionic ion-association complexes capable of being extracted by organic solvents. The anion extracted may be a simple oxy-anion such as ReO_4^- or ClO_4^- , or it may be a halo or thiocyanate

complex such as TlBr_4^- or $\text{Zn}(\text{SCN})_4^{2-}$.

All the basic dyes can be considered to be acid-base indicators as they change in colour with increasing hydrogen ion concentration in the solution, which is due to successive additions of protons to the amino groups of the dye molecule⁽²⁹⁰⁾. Only the singly charged form of the dye is capable of reacting to give an ion-association complex with an anion. The spectra of the organic extracts are very similar to those of aqueous solutions containing the dye in its singly charged form. The concentration of the singly charged cation decreases with increasing concentration of hydrogen ion. Thus the pH of the solution affects the extractabilities of the salts of cationic dyes; the limits of extraction depend on the nature of the cation and of the complex anion⁽²⁸⁸⁾. On formation of the basic dye-anion ion pair the reactions of the participating anions and cations with the solvent (water) dipoles become much weaker and this leads to the formation of a solid phase or by means that it can easily be extracted by a solvent of low polarity, i.e. extraction is on the basis of a loss in affinity for water⁽²⁹¹⁾.

The dye complexes are extracted into relatively polar solvents such as chloroform. Different solvents have been used as extractants for different complexes but the most satisfactory solvent in many cases seems to depend mainly on the dye used^(287,292). The selectivity of each extractant varies with the type of the dye as well as with the nature of the complex formed. In general, an increase in molecular weight of the dye cation increases the solubility of the ion pair in the organic solvent⁽²⁸⁹⁾. The solubility of complexes in various media depends upon the nature of the anion also, e.g. halide salts of dyes are readily soluble in water and almost insoluble in benzene or toluene.

The selective formation of basic dye association complexes with particular anions and their rapid complete extraction in hydrophobic solvent give an indication of great potential for use in selective-ion electrode studies. Entwistle and Hayes⁽²⁹³⁾ were among the first to make successful use of basic dye salts in electrode technology.

Brilliant Green which is used throughout the present work, for preparing water insoluble Brilliant Green ion association complexes, is pH dependent⁽²⁹⁴⁾. It remains in its useful R^+ form between pH 4.5 - 7.0. Below pH 4.5, the R^+ form of Brilliant Green is further protonated to the RH^{2+} form; above pH 7.0, the carbinol base is formed (fig. 18), which does not form an extractable species.

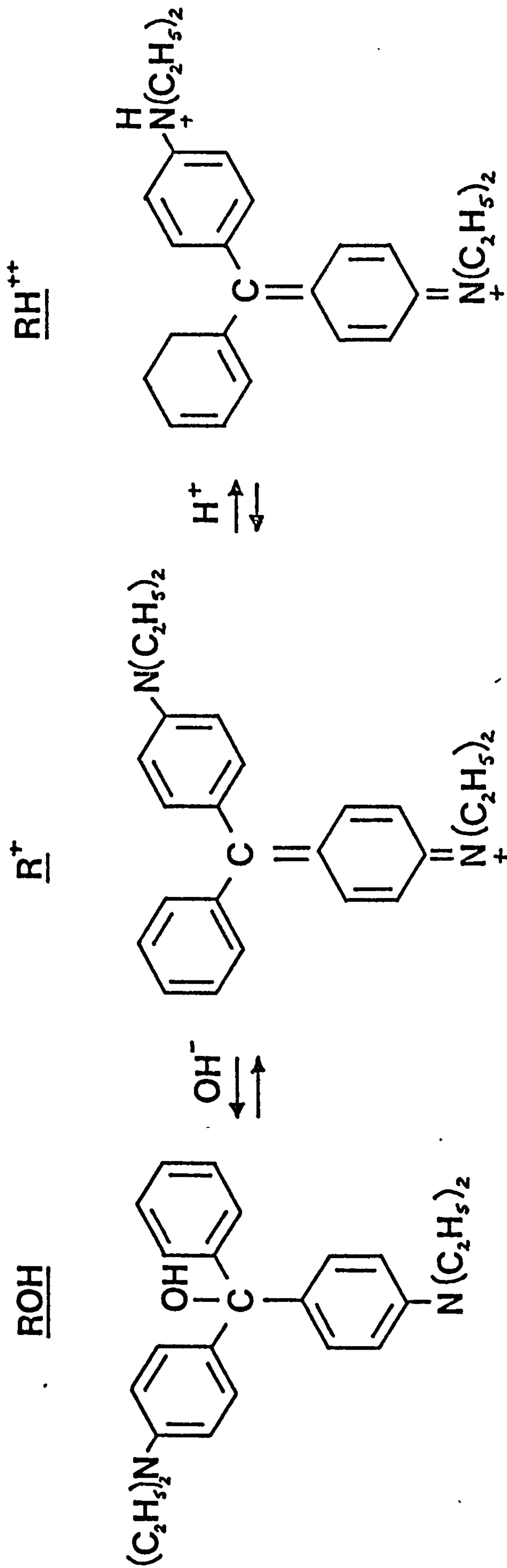

ACID-BASE EQUILIBRIA OF BRILLIANT GREEN

Figure (18)

ZINC ION-SELECTIVE ELECTRODE BASED ON BRILLIANT
GREEN TETRATHIOCYANATOZINCATE(II).

INTRODUCTION

A liquid state ion-selective electrode based on a basic dye salt was developed by Entwistle and Hayes⁽²⁹³⁾ for the determination of uranium. The ion exchanger was a 5×10^{-4} M solution of a Methylene blue tribenzoatodioxouranate(VI) in o-dichlorobenzene held on an inert membrane support. In the determination, excess benzoate was added to complex Uranium(VI) in the sample solution. The electrode responds to the concentration of tribenzoatodioxouranate(VI) anion $\left[(-57.6 \pm 0.5 \text{ mV}) \text{ per decade change in concentration at } 20^{\circ}\text{C} \right]$.

Slovák and Příbyl⁽²⁹⁵⁾ extracted the Rhodamine B tetrathiocyanatozincate ion-association complex into diethyl ether in pH range 5.5 - 6.5. In the present work Brilliant Green tetrathiocyanatozincate(II) has been prepared and applied in an ion-selective electrode for zinc. Liquid state, heterogeneous silicone rubber and carbon paste electrodes have been prepared and studied. The liquid state electrode consisting of ion-exchanger supported on lightly cross-linked natural rubber, was the most satisfactory. The electrode is strictly ion-selective for the tetrathiocyanatozincate(II) anion.

EXPERIMENTAL

Preparation of Brilliant Green tetrathiocyanatozincate(II)

The basic dye salt was prepared by using analytical reagent grade chemicals. Stoichiometric amounts of zinc acetate and potassium thiocyanate were dissolved in tri-distilled water. To this solution, a slight excess of Brilliant Green (British pharmacopoeia grade) was added at room temperature. The precipitate was filtered, washed with distilled water and dried at 45°C .

Preparation of the Electrodes.

a. Liquid-state electrode was prepared as described earlier (P.75).

The solubility of Brilliant Green tetrathiocyanatozincate(II) was examined in various solvents. o-Dichlorobenzene was found to be the most suitable of the solvents which swell the membrane, as it dissolved the maximum amount of dye salt giving a solution of 10^{-3} M concentration. A piece of natural rubber of 0.18 cm. thickness when soaked in the solution, was found to swell adequately and the basic dye salt was found to be distributed uniformly throughout the sheet without any sign of adsorption onto the surface of the rubber.

b. Heterogeneous silicone rubber membrane was prepared from the basic dye salt, silastomer 72 and catalyst BC in the ratio 4:4:1. Detailed methods of membrane preparation and electrode assembly were as before (P. 72).

c. Carbon paste electrode⁽²⁹⁶⁾ was prepared using spectral grade powdered graphite (Johnson Matthey Metals Limited). Brilliant Green tetrathiocyanatozincate(II) was dissolved in bromonaphthalene to give a 2% w/v saturated solution. 4g. of graphite powder was thoroughly mixed with 3 mls. of dye salt solution to get a useable paste. The resulting paste was filled in a cavity of a Teflon rod to form the electrode.

Evaluation of Performance of Electrodes

For the preparation of tetrathiocyanatozincate(II) solutions, zinc acetate and potassium thiocyanate of analytical reagent grade were used. Sample solutions were prepared by adding solid potassium thiocyanate to zinc acetate solution prepared in tri-distilled water.

The solutions contained excess of thiocyanate ion in order to keep the equilibrium on the right hand side, zinc ions being converted quantitatively to tetrathiocyanatozincate(II) ions. As with other silicone rubber membrane electrodes, the Brilliant green tetrathiocyanatozincate(II) membranes require presoaking. Membranes were kept in 10^{-3} M tetrathiocyanatozincate(II) solutions for about 24 hours prior to use. The liquid-state and carbon paste electrodes did not need any presoaking and could be used directly after their preparation. The electrodes when used for potentiometric determinations formed part of electrochemical cell which can be written as:



According to Nernstian equation, the potential would be given as

$$E = E^0 + 2.303 \frac{RT}{2F} \log C_x^{2+}$$

where C_x^{2+} is concentration of tetrathiocyanatozincate(II) ion. All the three types of electrodes were examined for zinc, thiocyanate and tetrathiocyanatozincate(II) ions response. The electrodes did not give any meaningful response when used in separate solutions of zinc and thiocyanate ions, but only responded to tetrathiocyanatozincate(II) ions. The liquid-state electrode responded immediately when placed in tetrathiocyanatozincate(II) ions solutions, giving a desired potential-concentration slope of 29.5 mV per decade change in concentration. The silicone rubber membrane and the carbon-paste electrodes responded within 10 to 15 minutes, producing smaller slopes. The results obtained are summarized in tables 21 and 22.

TABLE (21) Response of electrode to zinc and thiocyanate ions.

Concentration (M)	Potential (mV)	
	Zinc ion	Thiocyanate ion
10^{-1}	+11	-56
10^{-2}	+ 5	-21
10^{-3}	-10	-22
10^{-4}	-17	-23
10^{-5}	-24	-20

TABLE (22) Response of electrode to tetrathiocyanatozincate(II) concentrations.

Concentration (M)	Potential (mV)		
	Silicone rubber membrane electrode	liquid state membrane electrode	carbon-paste electrode
10^{-1}	-245.0	+51.5	-129.5
5×10^{-2}		+67.0	
10^{-2}	-224.0	+81.5	-108.5
5×10^{-3}		+95.0	
10^{-3}	-202.0	+111.0	-79.5
5×10^{-4}		+121.0	
10^{-4}	-182.0	+128.0	-53.0

Determination of Interferences

In order to determine the interference effect on the liquid state electrode, its response towards such ions as nickel(II), cobalt(II), lead(II) and iron(III) was studied. The results are given in table 23 and shown graphically in figure 19.

TABLE (23) Response of liquid state electrode to interfering ions.

Concentration (M)	Potential (mV)			
	Nickel	lead	Cobalt	Iron
10 ⁻¹	+154.0	precipitate	+92.0	+33.0
10 ⁻²	+156.0	+160.0	+121.0	+92.0
10 ⁻³	+156.0	+162.0	+142.0	+132.0
10 ⁻⁴	+155.0	+166.0	+153.0	+142.0
10 ⁻⁵	+153.0	-	+162.0	-

Calculation of selectivity constants

In the present case, selectivities of tetrathiocyanatozincate(II) and interfering ions were determined by using the potentials of two separate solutions (primary and interfering ion solutions) at the same concentration. The selectivities are calculated for 10⁻³ and 10⁻¹ M solutions.

The equation 54 (Appendix 1) was used for calculating selectivity constants of various ions:

$$\log K_{\text{zn(SCN)}_4^{2-} / \text{interf}} = \frac{E_1 - E_2}{2.303 RT/ZF}$$

where E₁ and E₂ are the individual potentials measured in solutions of pure tetrathiocyanatozincate(II) ion solution and interfering ion solutions. The results for liquid state electrode are shown in Table 24.

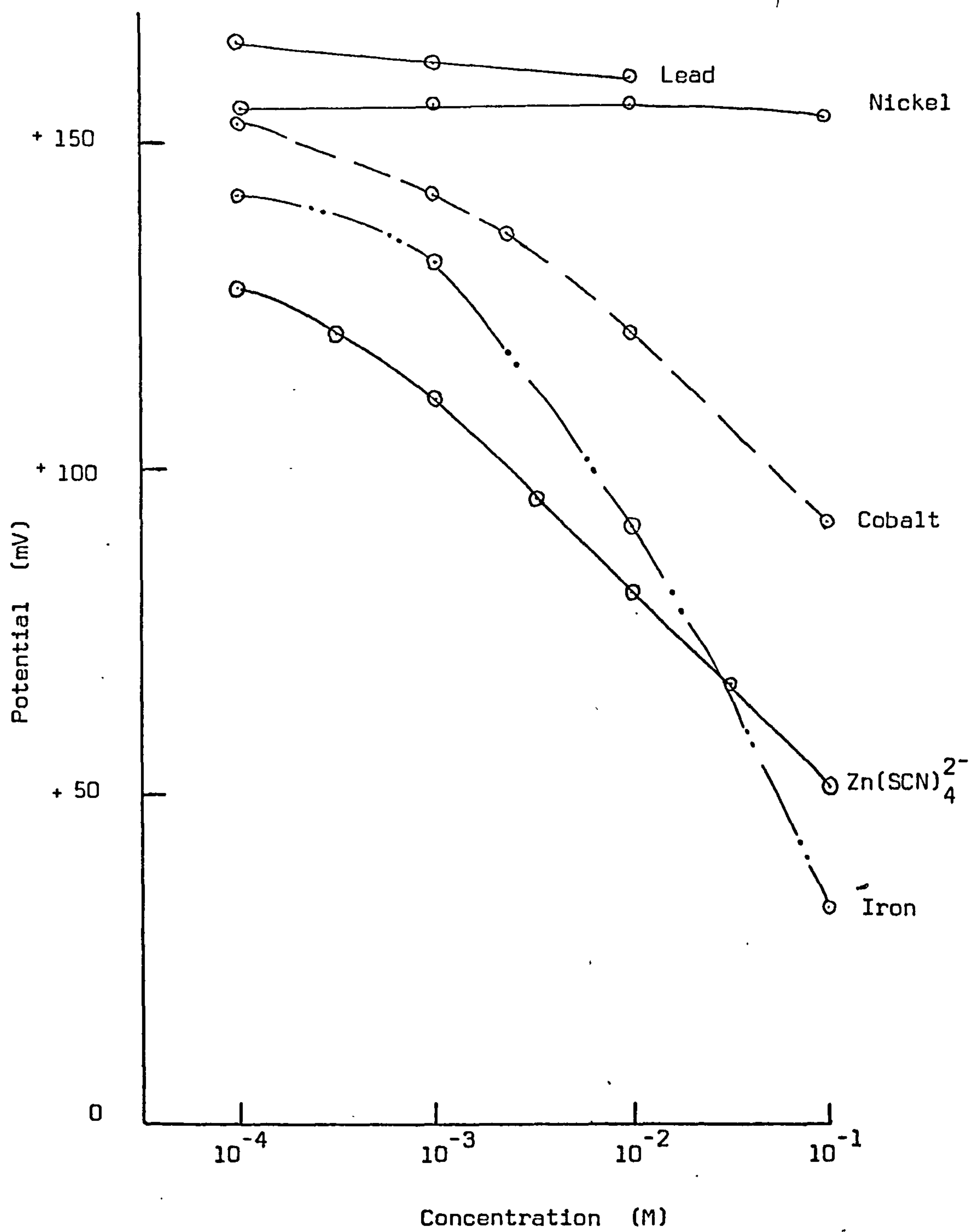

Figure (19)

Response of liquid-state electrode

TABLE (24) Selectivity constant $K_{\text{Zn}(\text{SCN})_4^{2-}/\text{Interf. ions.}$

Interfering ions	Selectivity constant	
	10^{-1} M	10^{-3} M
Nickel	3.39×10^{-4}	3.02×10^{-2}
lead	precipitate	1.9×10^{-2}
cobalt	4.3×10^{-2}	8.9×10^{-2}
Iron	5.5	0.19

Study of pH effects on electrode potential

The liquid-state electrode was used to observe the effect of pH variations of tetrathiocyanatozincate(II) ion solution, on its performance. The results are shown in table 25, figure 20.

TABLE (25) Electrode response as a function of pH.

pH	Potential (mV)	pH	Potential (mV)
2.5	+91.0	5.0	+79.0
3.0	+83.0	6.0	+79.0
3.5	+79.0	7.1	+79.0
4.0	+79.0	8.0	+79.0
		>8.0	precipitate

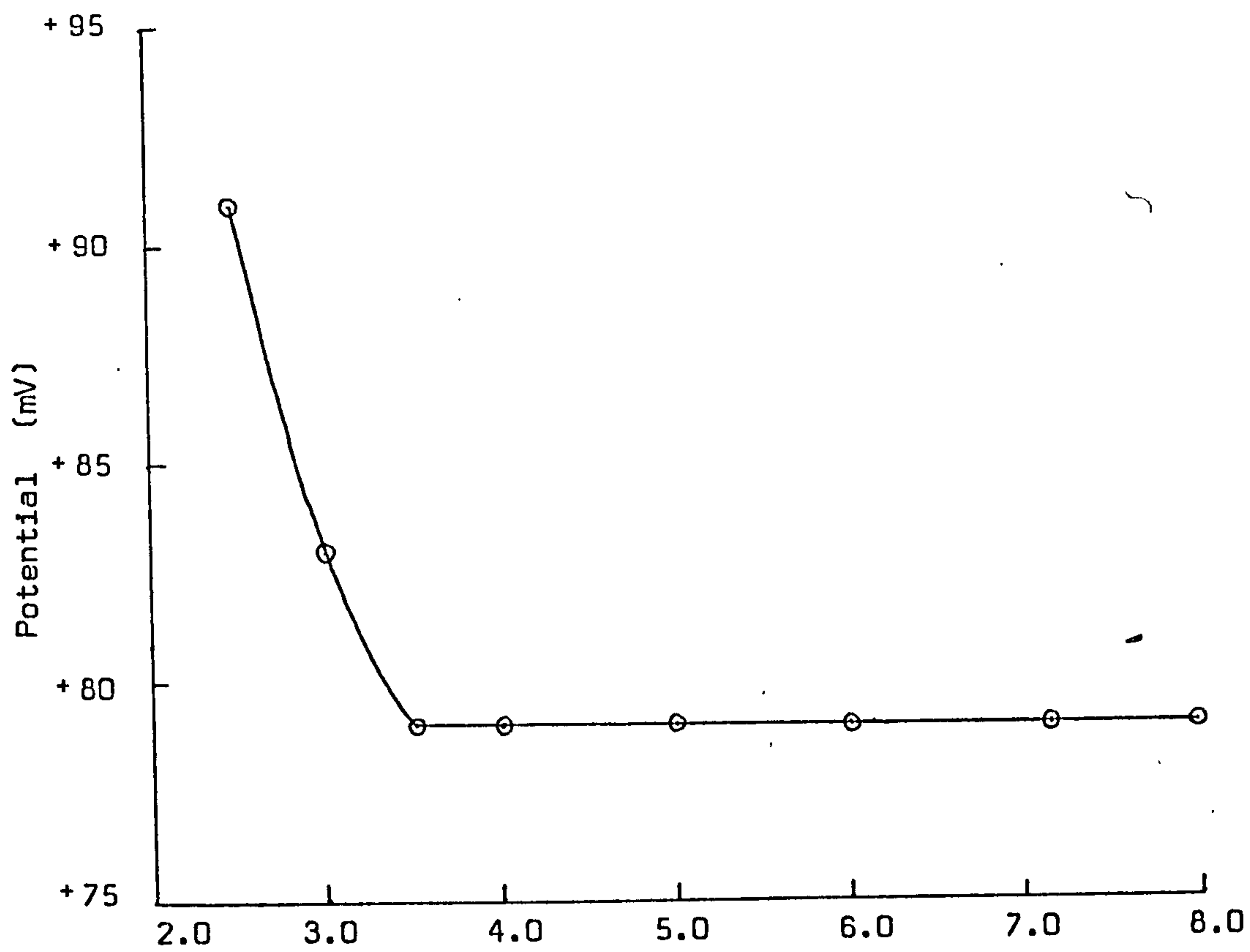

pH of tetrathiocyanatozincate(II) solution

Figure (20)

Electrode response as a function of pH

DISCUSSION

The three types of electrodes based on Brilliant Green complex, when employed in solutions of zinc and thiocyanate ions present in separate solutions, responded only slightly to concentration changes of those ions. However, the electrodes responded in a Nernstian or near Nernstian manner when both ions were present together forming tetrathiocyanatozincate(II) ions. Only the liquid-state electrode was found to respond desirably. The potential-concentration slope of 29.5 mV per decade change in concentration obtained by liquid-state electrode was the expected theoretical response. The silicone rubber and carbon paste electrodes also gave near Nernstian response but the slope was lower and the time of response was much slower. The response time of the liquid-state electrode was under one minute, whereas the other types of electrodes only gave a steady response after 10 to 15 minutes. Interference effects on electrode response was studied for a limited number of metal-complex solutions. The liquid-state electrode when tested was shown not to respond, in the presence of thiocyanate, to changes in concentration of lead or nickel. Copper(II) did not interfere as copper(I) thiocyanate is precipitated. The electrode responded to changes in concentrations of cobalt and iron(III) especially at high concentrations. The electrode was found to respond independently of pH between pH 3.5 to 8.0; above pH 8.0 precipitation takes place.

Thus, the liquid-state electrode could be useful in direct determinations of zinc after converting it to tetrathiocyanatozincate (II) ion in absence or presence of interfering ions, within specified limits.

PERCHLORATE ION-SELECTIVE ELECTRODE

INTRODUCTION

The Orion liquid state ion selective electrode for perchlorate has been used by Baczuk and Dubois⁽²⁹⁷⁾, and by Smith and Manaham⁽²⁹⁸⁾, for potentiometric titration of perchlorate with tetraphenylarsonium chloride. Hseu and Rechnitz⁽²⁹⁹⁾ have evaluated the electrode in detail and have used it to determine solubility products of several perchlorate salts. Other workers have developed perchlorate electrodes based on different ion-exchangers. The electrodes of Ishibashi and Kohara⁽²²⁷⁾ are based on perchlorate salts formed from o-phenanthroline and from two other related chelating agents, whereas Sharp^(149,228,229), has reported solid-state and liquid membrane electrodes based on organic radical ion salts.

In the present investigation on water-insoluble basic dye salts as sensing materials for use in ion-selective electrodes, a reliable liquid-state electrode selective for perchlorate has been developed. In this electrode a natural rubber matrix saturated with a solution of Brilliant Green perchlorate in chlorobenzene has been used as a membrane.

EXPERIMENTAL

Preparation of Brilliant Green perchlorate

Kerr and Gregory⁽³⁰⁰⁾ have described the preparation of Brilliant Green perchlorate as a means of purifying Brilliant Green for colorimetric use. A similar procedure was used herein, although a relatively pure initial sample of Brilliant Green (British pharmacopocia grade) was used. One gram of Brilliant Green was dissolved in 200 mls. of tri-distilled water (0.5% w/v) and heated up to 75°C on water bath.

26 grams of sodium perchlorate (A.R.) dissolved in 40 mls. of tri-distilled water was added to the dye solution whilst constantly stirring it. A coarse precipitate appeared immediately; the completeness of precipitation was ensured by addition of a slight excess of sodium perchlorate solution. After adjusting the mixture to pH 1 - 1.5 with perchloric acid (A.R.), the mixture was kept at 75°C for 5 minutes. The precipitated Brilliant Green perchlorate was then filtered and washed with water several times until free from acid and soluble salts. The precipitates was then recrystallised from ethanol-water (4:1), dried at 45°C under vacuum and stored in a desiccator.

Kerr and Gregory⁽³⁰⁰⁾ have recommended the use of dye perchlorate samples in colorimetric work within 3 to 4 weeks of preparation, due to deterioration after this period. In the present work quite satisfactory results were obtained using material even 8 weeks after its preparation.

Owing to the potentially explosive nature of organic perchlorates, it may be considered preferable not to prepare samples of dry solid Brilliant Green perchlorate. For this reason an alternative method of preparing a solution of Brilliant Green perchlorate in chlorobenzene was devised. In this method the precipitated Brilliant Green perchlorate was extracted directly into a minimum amount of chlorobenzene without filtration. The chlorobenzene solution was freed from water droplets subsequently by passing it through filter paper. Providing a sufficiently concentrated solution of Brilliant Green perchlorate was used (about 3% w/v), electrodes prepared in this manner behaved as satisfactory as those prepared using solid Brilliant Green perchlorate.

Choice of the Rubber in electrode preparation

Commercial natural rubber sheetings (Trade No. 7190 grey, 9808 black and 6720 (B)) were obtained from Harborough Rubber Company.

Sample 7190 grey rubber was satisfactorily used as inert membrane matrix because of its rapid absorption of the dye perchlorate solution and giving slightly higher potential-concentration slope than the other samples. Brilliant Green perchlorate was found to dissolve in toluene, benzene and chlorobenzene, the maximum solubility being in chlorobenzene. In order to choose the best solvent which could be absorbed by the membrane quickly and completely, pieces from the same sheet of rubber (7190 grey) were put into solutions of the dye perchlorate in toluene (A.R.), benzene (A.R.) and chlorobenzene (pure). The rubber piece soaked in 3% w/v chlorobenzene solution of Brilliant Green perchlorate was saturated with the dye salt within six hours. The basic dye salt was found to be evenly distributed through it and the membrane swelled to twice its original size. On the other hand the toluene solution was not absorbed by the rubber even after soaking for over four weeks, but the rubber sheet immersed in benzene solution was saturated with the dye salt solution within about four days. Therefore, chlorobenzene was chosen and used as the solvent in the membrane preparation. The membrane used in the electrode body was already described earlier (P.75)

Evaluation of the electrode

The prepared electrode was used to study its response to Brilliant Green, perchlorate ion and potentially interfering anions. A 10% (w/v) ammonium nitrate solution was used in the outer chamber of the reference electrode in order to avoid the formation of sparingly soluble potassium perchlorate which otherwise could block up the reference electrode.

According to the Nernst equation, the potential of the electrochemical cell would be given as:

$$E = E^{\circ} + 2.303 \frac{RT}{F} \log a_x$$

where x could be perchlorate or Brilliant Green ions; therefore, the potential of the cell was a function of ion-activities of those ions.

During the first 24 hours after the preparation of the electrode the potential drifted by as much as 12 mV in the negative direction, whereas after two weeks the potential was 23 mV more negative for the same solution. When the electrode was used on the same day for two different solutions of the same concentration the reproducibility found was within 0.5 to 1.0 mV. Furthermore at 10^{-2} to 10^{-1} M the potential was stable for at least half an hour, but a slight drift was noticed in negative direction after 10 minutes at lower activity. The electrode functioned almost immediately on initial immersion in the test solutions. The response times were usually under one minute in reference ion solutions but were in the range of about 5 minutes in interfering ion solutions; the electrode did not require any pre-soaking. Concentrations of perchlorate and interfering ions were corrected to their activities by using an extended form of Debye-Hückel equation 39⁽²⁸⁶⁾.

$$-\log f = \frac{A z^2 \sqrt{I}}{1 + \sqrt{I}}$$

Determination of Brilliant Green and perchlorate ions

For preparation of perchlorate solutions, analytical reagent grade sodium perchlorate was dissolved in tri-distilled water to give a molar stock solution. Subsequent solutions were prepared by serial dilutions. Brilliant Green (B.P. grade) was used to prepare a stock solution of 10^{-3} M concentration, which was used for further desired dilutions. The potential shown by the electrode for varying concentrations of Brilliant Green and perchlorate ions is given in table 26 (figure 21).

TABLE (26) Response of electrode to (a) Brilliant green
(b) Perchlorate ions

(a) Ion activity (M)	Potential (mV)	(b) Ion activity (M)	Potential (mV)
5×10^{-4}	+294.0	10^{-1}	+103.0
10^{-4}	+265.5	10^{-2}	+160.5
5×10^{-5}	+237.5	10^{-3}	+218.0
10^{-5}	+209.0	5×10^{-4}	+246.0
5×10^{-6}	+204.5	10^{-4}	+265.0

Study of Interfering ions

The interfering effect of various univalent anions on the perchlorate ion-selective electrode was studied. The electrode was used in separate solutions of Cl^- , Br^- , I^- , NO_3^- , CH_3COO^- , F^- and HCO_3^- ; the response towards various anions is given in table 27, figure 21, where it is seen that the degree of interference varies with different anions. Selectivity constants for interfering ions are given in table 28.

TABLE (27) Response of the electrode towards different anions

Ion activity M	Potential (mV)						
	Cl^-	Br^-	I^-	NO_3^-	CH_3COO^-	F^-	HCO_3^-
10^{-1}	+246.0	+232.0	+168.0	+213.0	+235.0	+259.0	+200.5
10^{-2}	+252.0	+249.0	+195.0	+235.0	+243.0	+266.0	+225.0
10^{-3}	+264.0	+264.0	+222.0	+258.0	+258.0	+272.0	+249.0
10^{-4}	+274.0	+279.0	+239.0	+277.0	+270.0	+278.0	+269.0

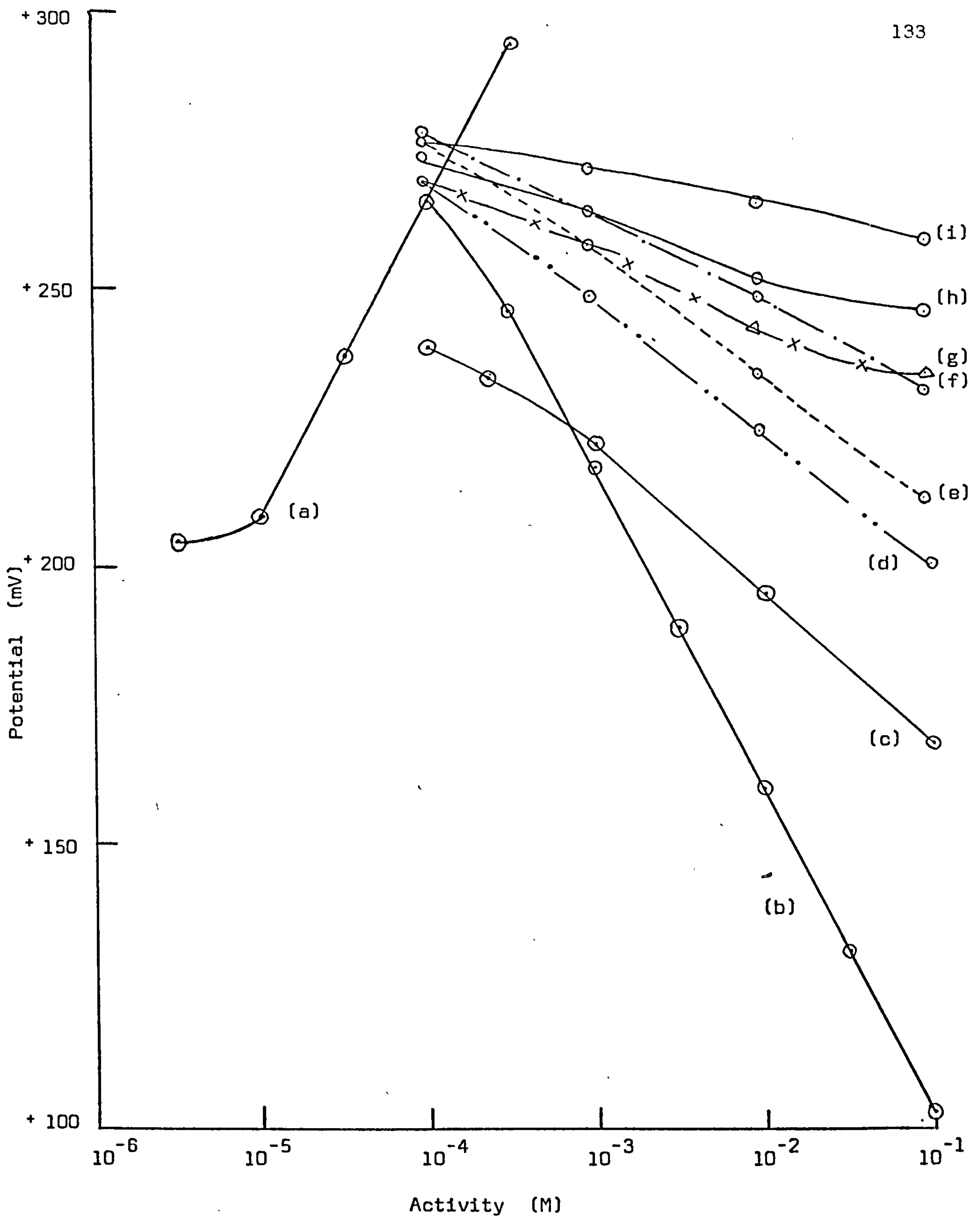

Figure (21)

Response of perchlorate ion-selective electrode towards different ions:
 (a) Brilliant Green (b) Perchlorate (c) Iodide (d) Bicarbonate
 (e) Nitrate (f) Bromide (g) Acetate (h) Chloride
 (i) Fluoride

TABLE (28) Selectivity constants $[K_{\text{ClO}_4^-/\text{Interf.}}]$

Interfering ions	Selectivity constants	
	Potential difference method	Constant Potential method
I ⁻	0.08 - 0.85	0.09
HCO ₃ ⁻	0.02 - 0.29	0.5
NO ₃ ⁻	0.013 - 0.21	0.15
Br ⁻	0.0066 - 0.16	0.008
CH ₃ COO ⁻	0.006 - 0.21	0.007
Cl ⁻	0.0037 - 0.17	0.005
F ⁻	0.0023 - 0.12	0.003

These were calculated in two ways, first using equation 54 (Appendix I):

$$\log K_{\text{ClO}_4^-/\text{interf}} = \frac{E_{\text{ClO}_4^-} - E_{\text{interf}}}{2.303 RT/F}$$

The constants were calculated for minimum and maximum values of $E_{\text{ClO}_4^-} - E_{\text{interf}}$ within the activity range 10^{-3} M to 10^{-1} M. Constants were also calculated by comparing the activities of perchlorate and interfering ions that were required to give the same potential (Equation 56, Appendix I).

$$\text{ie. } K_{\text{ClO}_4^-/\text{interf.}} = \frac{a_{\text{ClO}_4^-}}{a_{\text{interf.}}}$$

Effect of pH on electrode response

pH has a great influence on observed response of the present electrode. The effect of pH of the test solution on the electrode potential was studied by using 10^{-1} M and 10^{-3} M solutions of sodium perchlorate. Dilute hydrochloric acid and sodium hydroxide solutions

were used to vary the pH of the test solution

between 2.5 and 9.0. The electrode responses are shown in table 29,

(figure 22).

TABLE (29) Electrode response as a function of pH and perchlorate activities.

pH	Potential (mV)	
	10^{-1} M	10^{-3} M
2.5	+79.5	-
3.0	+72.5	+215.0
4.0	+70.2	+199.5
4.5	+69.5	+195.5
5.0	+69.5	+195.5
*6.2/6.36	+69.5	+195.5
7.0	+69.5	+195.5
8.0	+69.5	+195.5
8.5	+64.8	+189.0
9.0	+64.0	+188.0

* Initial pH of 10^{-1} M solution was 6.2 and that of 10^{-3} M solution was 6.36.

Study of the effect of temperature on potential

A brief study was made of the effect of temperature on the response of the electrode, the data obtained is given in table 30 (figure 23).

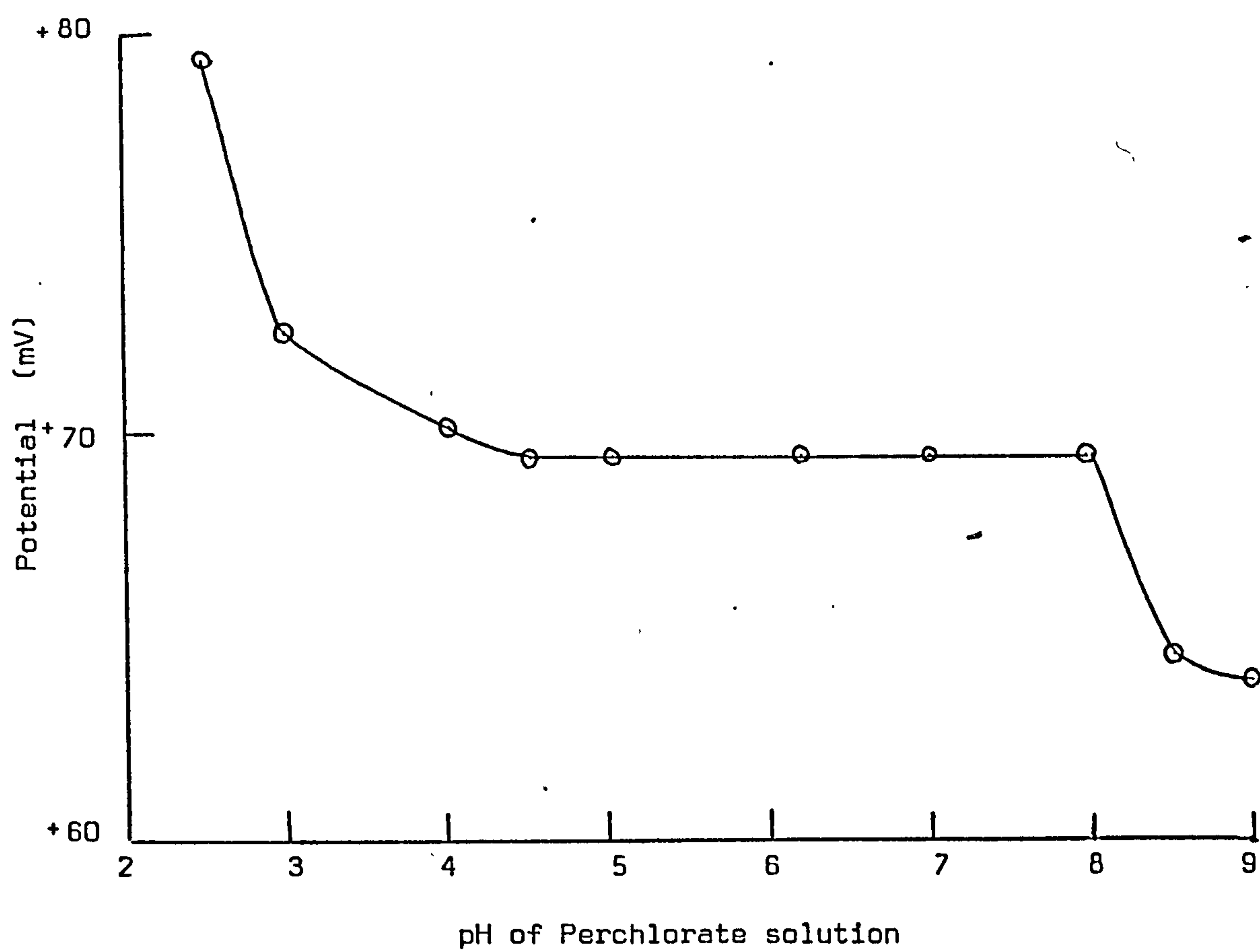

Figure (22)

Electrode response as a function of pH.

TABLE (30) Potential of the electrode as a function of temperature.

Ion activity (M)	Potential (mV)		
	25 ^o C	35 ^o C	45 ^o C
10 ⁻¹	+80.0	+81.0	+77.0
10 ⁻²	+137.0	+138.0	+137.5
10 ⁻³	+194.0	+195.0	+198.5
5 x 10 ⁻⁴	+221.0	+226.0	+232.0
10 ⁻⁴	+239.0	+250.0	+255.0

Application of Perchlorate ion-selective electrode in potentiometric titrations.

The perchlorate electrode was used in potentiometric precipitation titration of perchlorate with tetraphenylarsonium chloride. This procedure provides the possibility of rapid, accurate and selective determination of perchlorate. General purpose reagent grade tetraphenylarsonium chloride (B.D.H.) was used to prepare a 0.05 M solution which was used without standardisation but aliquots were adjusted to pH 5.0 before titration. 50 mls. of 0.05 M sodium perchlorate (A.R.) solution was used for the titration. The data obtained are given in table 31. A distinct end-point was obtained at 52.8 ml of tetraphenylarsonium chloride as shown in figure 24. Due to non-availability of any commercial perchlorate ion-selective electrode in this laboratory, it was not possible to compare the observed end-point obtained in the present titration. However the same titration was repeated several times and each time the end-point was obtained within ± 0.1 ml of the stated value.

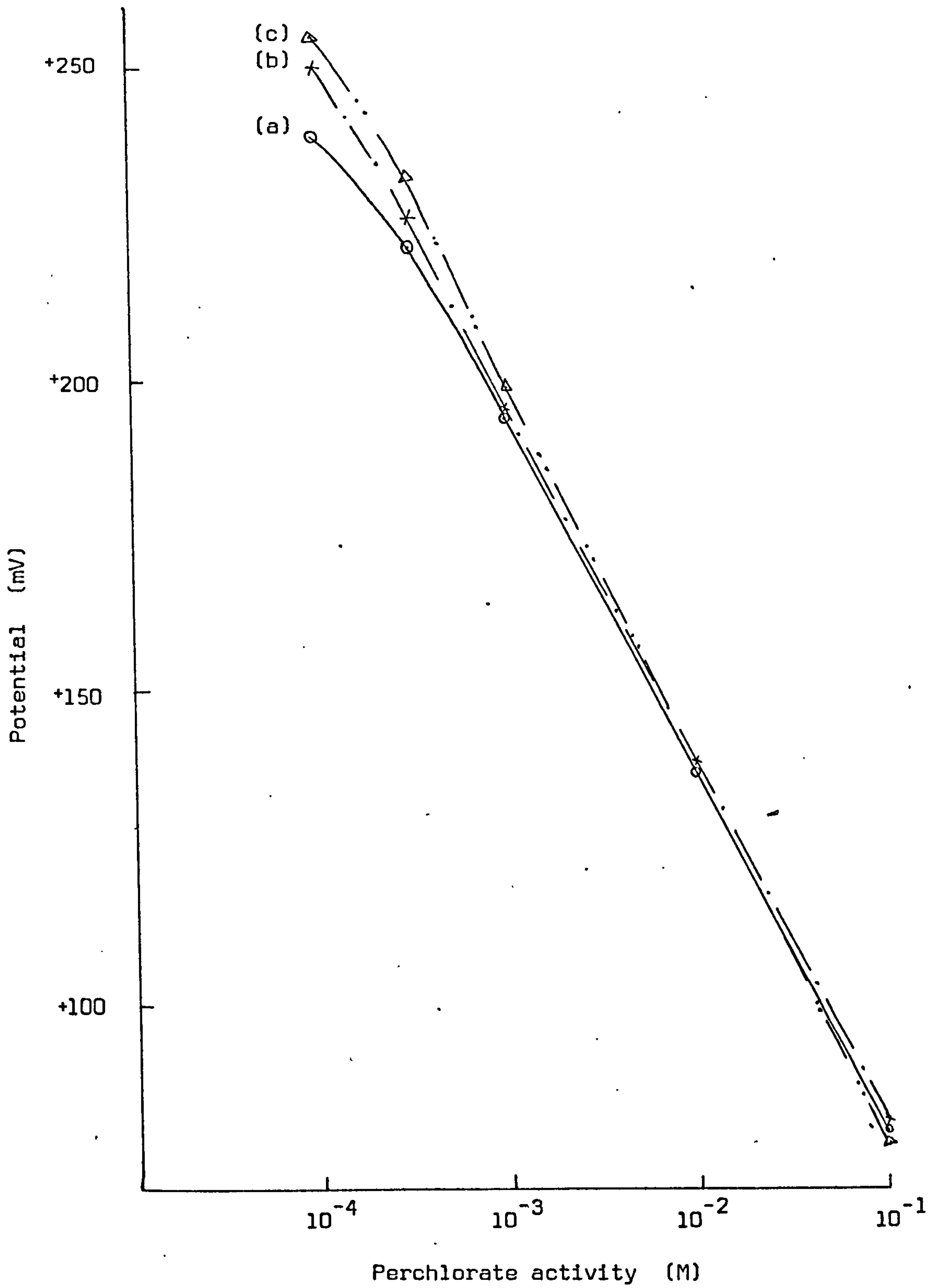

Figure (23)

Potential of the electrode as a function of temperature:
(a) 25°C (b) 35°C (c) 45°C

TABLE (31) Potentiometric titration of perchlorate with tetraphenylarsonium chloride.

Amount of titrant added (mls)	Potential (mV)	Amount of titrant added (mls)	Potential (mV)
0.0	+88.5	51.0	+179.0
1.0	+89.5	52.0	+198.0
4.0	+91.7	52.5	+204.0
9.0	+96.0	52.6	+208.0
16.0	+102.5	52.7	+216.0
25.0	+112.0	52.8	+240.0
35.0	+125.0	53.0	+248.0
42.0	+139.0	54.0	+263.0
46.0	+152.0	55.0	+277.0
48.0	+159.0	56.0	+284.0
49.0	+164.0	57.0	+288.0
50.0	+171.0		

The observed end-point is at 52.8 ml of tetraphenylarsonium chloride.

DISCUSSION

The perchlorate ion-selective electrode described here is another example of a successful electrode based on water-insoluble basic dye salts as ion-sensor. The response of the electrode to perchlorate, Brilliant Green and several interfering anions is shown in figure 21. The electrode responded linearly for 5×10^{-4} M to 10^{-1} M solutions of perchlorate and 5×10^{-4} M to 10^{-5} M solutions of Brilliant Green. Over the linear portions of the graphs for perchlorate and Brilliant Green the slopes are Nernstian (57.5 and 57.0 mV per decade change in ion-activity, respectively). Although the measured potentials of the electrode in the particular solution drifted, the slopes nevertheless remained Nernstian for at least two weeks.

The electrode did not need pre-soaking and responded immediately on immersion in the solution. A steady potential response was obtained for 10^{-3} to 10^{-1} M solutions for perchlorate or Brilliant Green within one minute and after slightly longer periods of time at lower concentrations; also the potentials obtained were stable for a reasonable time ranging from 30 to 10 minutes in higher to lower concentrations.

The result obtained from the study of the effect of solution pH on electrode performance has shown a constant potential response obtained within pH range 4.5 to 8.0. This is in agreement with the work reported by Fogg, Burgess and Burns⁽²⁹⁴⁾, who have extracted perchlorate by Brilliant Green into benzene from aqueous solution of pH 4.5 to 7.0. Effects of temperature variations on electrode response indicate the slopes of 57, 57 and 61 mV at 25, 35 and 45°C respectively compared with the theoretical slopes of these temperatures of 59, 61 and 63 mV.

A typical potentiometric titration curve (figure 24) for the titration of perchlorate with tetraphenylarsonium chloride shows an expected end-point. A higher end-point was expected because tetraphenylarsonium chloride which was used as a titrant was of unspecified purity.

Due to effect of pH on R^+ form of Brilliant Green which results in formation of protonated RH^{2+} form at lower pH and conversion to carbinol base at higher pH, the electrode has a slightly shorter working pH range than the commercial liquid state electrode.

Although the potentials are almost reproducible on the same day of working, even then for a precise measurement it is advisable to calibrate the electrode every day, because electrodes have shown drifts in potential at the rate of approximately 1.5 mV per day.

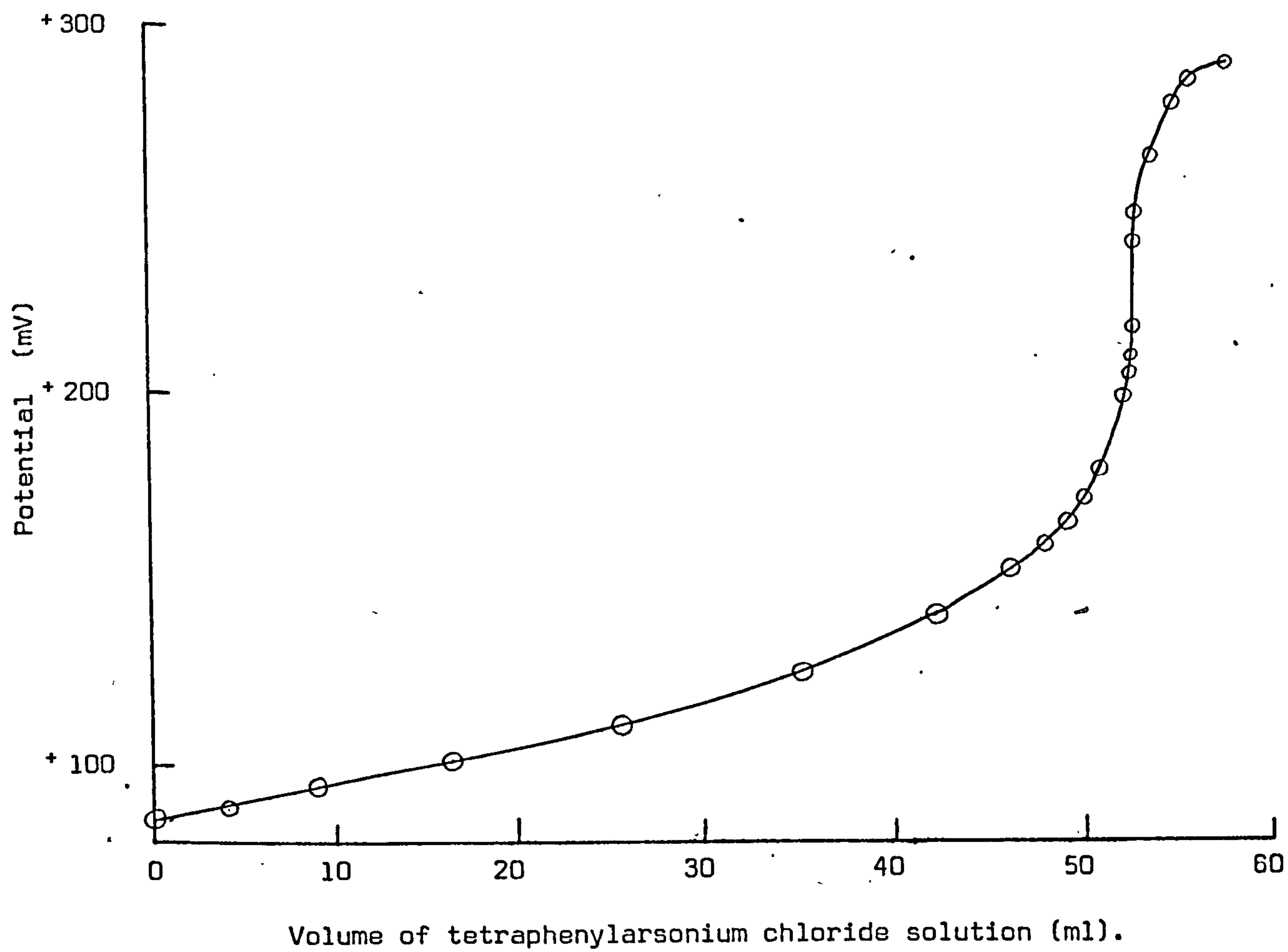

Figure (24)

Potentiometric titration of perchlorate with tetraphenylarsonium chloride

Apart from direct use of electrodes in potentiometric determinations of perchlorate, the electrode can be used successfully in potentiometric titrations which are intrinsically more precise. It is most probable that the electrode may also give acceptable results when employed for perchlorate determinations in explosives (titration with mercuric nitrate) and photographic productions provided that proper conditions of electrode working are maintained. Both these applications were described earlier by Orion.

TETRAFLUOROBORATE ION-SELECTIVE ELECTRODE

INTRODUCTION

Babko and Marchenko⁽³⁰¹⁾ have determined boron colorimetrically with Brilliant Green as the tetrafluoroborate-dye ion-association complex. Brilliant Green tetrafluoroborate has been used to develop a liquid-state ion-selective electrode sensitive to tetrafluoroborate ion. A chlorobenzene solution of the basic dye salt is absorbed into natural rubber sheeting which acts as the membrane in the electrode. The electrode has been used for potentiometric estimation of tetrafluoroborate and of potentially interfering ions.

EXPERIMENTAL

Preparation of Brilliant Green tetrafluoroborate

Brilliant Green tetrafluoroborate was prepared in polyethylene apparatus as follows. A saturated solution of sodium tetrafluoroborate (about 200 gs. dissolved in 250 mls. of tri-distilled water) was filtered to remove suspended impurities. To this solution was added whilst stirring about 100 mls. of a 4% w/v aqueous solution of Brilliant Green (British pharmacopoeia grade). The precipitate of Brilliant Green tetrafluoroborate formed immediately. This precipitate was filtered and washed thoroughly with tri-distilled water and dried under vacuum at 40°C.

Preparation of the electrode

The solubility of Brilliant Green tetrafluoroborate was examined in a variety of solvents; the maximum solubility, 2.5% w/v, was found to occur in chlorobenzene. The natural rubber membrane (grey 7190) was saturated with a chlorobenzene solution of dye salt by standing it in the solution overnight (about 10 hours). After this

time, the basic dye salt was found to be evenly distributed through it and the membrane swelled to twice its original volume and thickness. After drying the membrane with paper tissue, it was fixed in the electrode body as described earlier (P.75).

Evaluation of performance of the electrode

The electrode prepared was used, as a part of electrochemical cell similar to that already described, for potentiometric measurements of tetrafluoroborate and examination of interfering ions. Polyethylene vessels were used for all the solutions containing fluoride to avoid corrosion of glass containers. Four electrodes were prepared and each behaved satisfactorily.

The potentials of the cell containing tetrafluoroborate solutions are given according to Nernstian equation by:

$$E = E^0 - 2.303 \frac{RT}{F} \log a_{\text{BF}_4^-}$$

and potentials varied linearly due to change in ion activities of the solutions. Concentrations of various anions were corrected to respective activities by calculating their activity coefficients using the following form of Debye-Hückel equation 39⁽²⁸⁶⁾.

$$-\log f = \frac{Az^2 \sqrt{I}}{1 + \sqrt{I}}$$

standard laboratory reagent grade sodium tetrafluoroborate (Fisons Chemicals Limited) was recrystallised twice from aqueous solution and was used to prepare a molar stock solution of tetrafluoroborate ions which was used for the desired subsequent dilutions. For the study of the interfering effects of various anions on the electrode function, solutions of sodium salts of perchlorate, iodide, bicarbonate, nitrate, bromide, acetate, chloride, dihydrogenphosphate, fluoride and borate ions were used.

The electrode response for varying activities of difference anions is shown in Table 32 (Figure 35).

TABLE (32)

Response of tetrafluoroborate ion-selective electrode towards various anions.

Ion Activity (M)	Potential (mV)										
	BF_4^-	ClO_4^-	I^-	HCO_3^-	NO_3^-	Br^-	CH_3COO^-	Cl^-	H_2PO_4^-	F^-	Borate
10^{-1}	+107	+94	+220	+250	+258	+262	+274	+277	+293	+347	+367
10^{-2}	+165.5	+149	+250	+267	+275	+278	+287	+284	+308	+351	+368
10^{-3}	+224	+220	+275	+283	+291	+286	+297	+292	+326	+353	+370.5
5×10^{-4}	+253	-	-	-	-	-	-	-	-	-	-
10^{-4}	+276	+293	+298	+295	+299	+289	+308	+299	+348	+355	+372

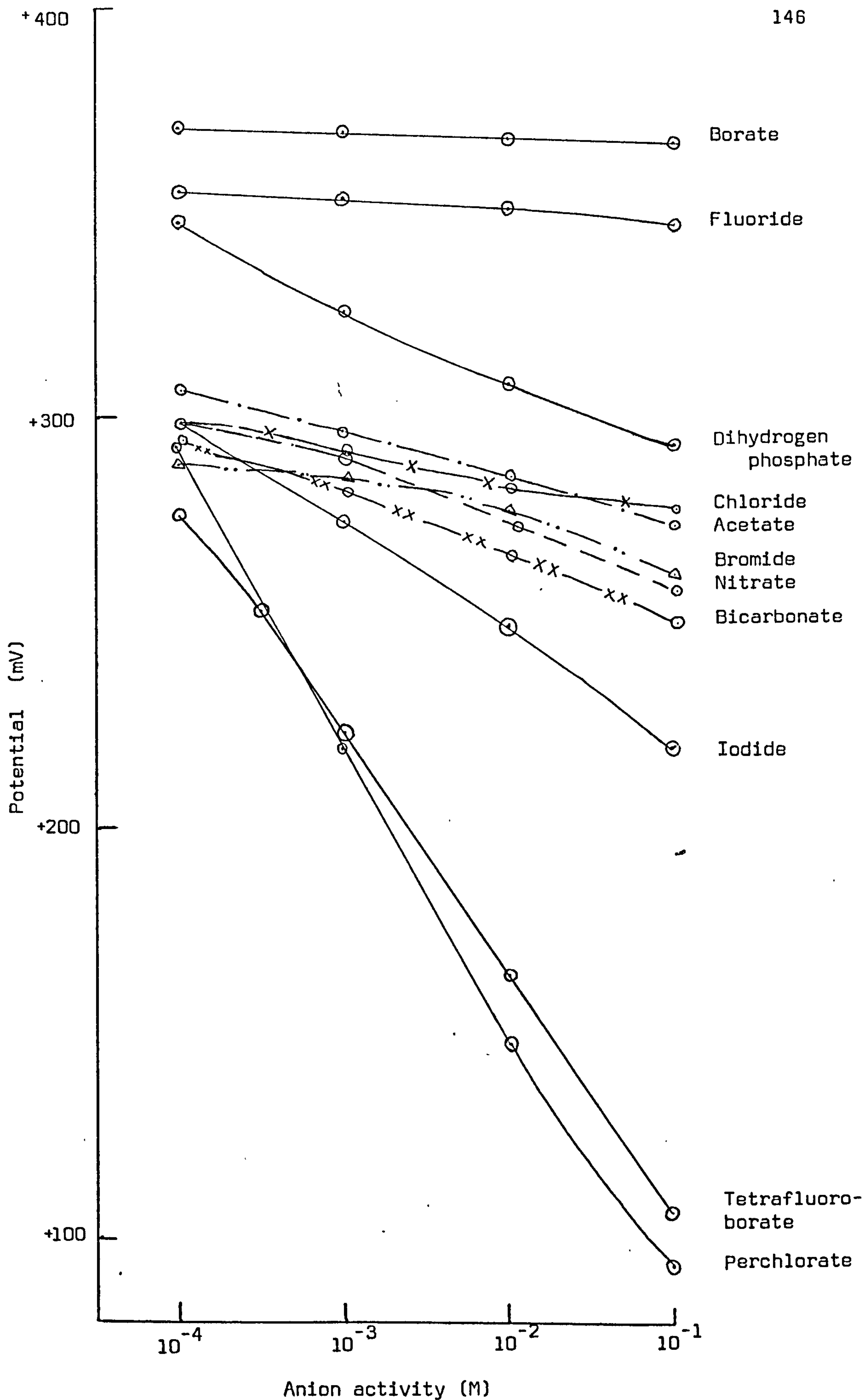

Figure (25)

Response of tetrafluoroborate ion-selective electrode towards different anions

Determination of selectivity constants

The selectivity constants calculated from the potentials shown in table 32 are given in table 33. These constants were calculated using the equation 54 (Appendix 1) for potential difference.

$$\log K_{\text{BF}_4^-/\text{interf.}} = \frac{E_{\text{BF}_4^-} - E_{\text{interf.}}}{2.303 \text{ RT/F}} \quad (\text{at constant activity})$$

These values were estimated for minimum and maximum values of $E_{\text{BF}_4^-} - E_{\text{interf.}}$ within the activity range 5×10^{-4} to 10^{-1} M.

TABLE (33) Selectivity constant ($K_{\text{BF}_4^-/\text{interf.}}$)

Interfering ions	Selectivity constants at		
	10^{-1} M	to	5×10^{-4} M
perchlorate	1.6	-	1.0
iodide	0.012	-	0.24
bicarbonate	0.004	-	0.26
bromide	0.002	-	0.26
nitrate	0.002	-	0.19
acetate	0.0015	-	0.15
chloride	0.001	-	0.19
dihydrogenphosphate	10^{-4}	-	0.04
fluoride	10^{-4}	-	0.02
borate	4×10^{-5}	-	10^{-2}

Study of the effect of pH

A knowledge of the pH range in which the electrode works correctly is of great importance, as beyond certain limits the change in solution pH effects the response of the electrode. In order to study the effect of pH and determine the operative range of the fluoroborate electrode;

the pH of a 10^{-2} M test solution was varied between 2.5 and 9.0, using dilute hydrochloric and sodium hydroxide solutions. The variations in the electrode response are given in table 34, (figure 26).

TABLE (34) Electrode response as a function of pH and concentration.

pH	Potential (mV)
2.5	+171.0
3.0	+168.0
3.4	+165.0
4.0	+165.0
5.0	+165.0
6.0	+165.0
7.0	+165.0
8.0	+165.5
9.6	+158.0

Effect of temperature on electrode response

To study the effect of temperature changes, the electrode was used in test solutions at three different temperatures, 25, 35 and 45°C. The electrode response as a function of temperature is shown in table 35, (figure 27).

TABLE (35) Electrode response as a function of temperature and concentration.

Ion activity (M)	Potential (mV)		
	25°C	35°C	45°C
10^{-1}	+108.5	+109.0	+110.0
10^{-2}	+167.0	+169.0	+172.0
10^{-3}	+225.0	+229.0	+234.0
5×10^{-4}	+254.5	+259.0	+265.0
10^{-4}	+277.0	+284.0	+292.0

DISCUSSION

Basic dyes have been used for colorimetric extractive determination of boron as tetrafluoroborate^(289,302-304). These methods are unsatisfactory because no solvent is available that extracts the basic dye tetrafluoroborate without extracting the excess of the basic dye reagent. Therefore either extraction is incomplete or there is a high reagent blank. This difficulty does not apply when basic dye fluoroborates are used as ion-exchangers in membrane electrodes. In this case there is no free dye in the sample solution and a solvent of high dielectric constant and high extractive power can be used with advantage. The electrode prepared herein responded rapidly giving a near theoretical potential-activity slope of 58.5 mV, over tetrafluoroborate activity range of 5×10^{-4} M to 10^{-1} M. From 10^{-4} to 10^{-3} activity the slope is 52 mV which is 11% less than that expected, but even then the electrode can be useful in applications for solutions down to 10^{-4} M. The steady-response time of the electrode in general, was under one minute but varied from 5 to 35 seconds going to more dilute solutions between 10^{-1} to 10^{-4} M.

Immediately after preparation, the potential of the electrode drifted quite considerably. Over a period of five weeks a further drift of 18 mV was observed, though the slopes remained constant throughout. The electrode response was found to be reproducible if used on the same day in solutions of same characteristics. The electrode gave a potential independent of pH between pH 3.5 and 8.0.

A brief study of the effect of temperature on the response of the electrode, indicated slopes of 58.5, 60.0 and 62.0 mV per decade activity of tetrafluoroborate ions at 25, 35 and 45°C respectively, compared to theoretical values of 59, 61 and 63 mV.

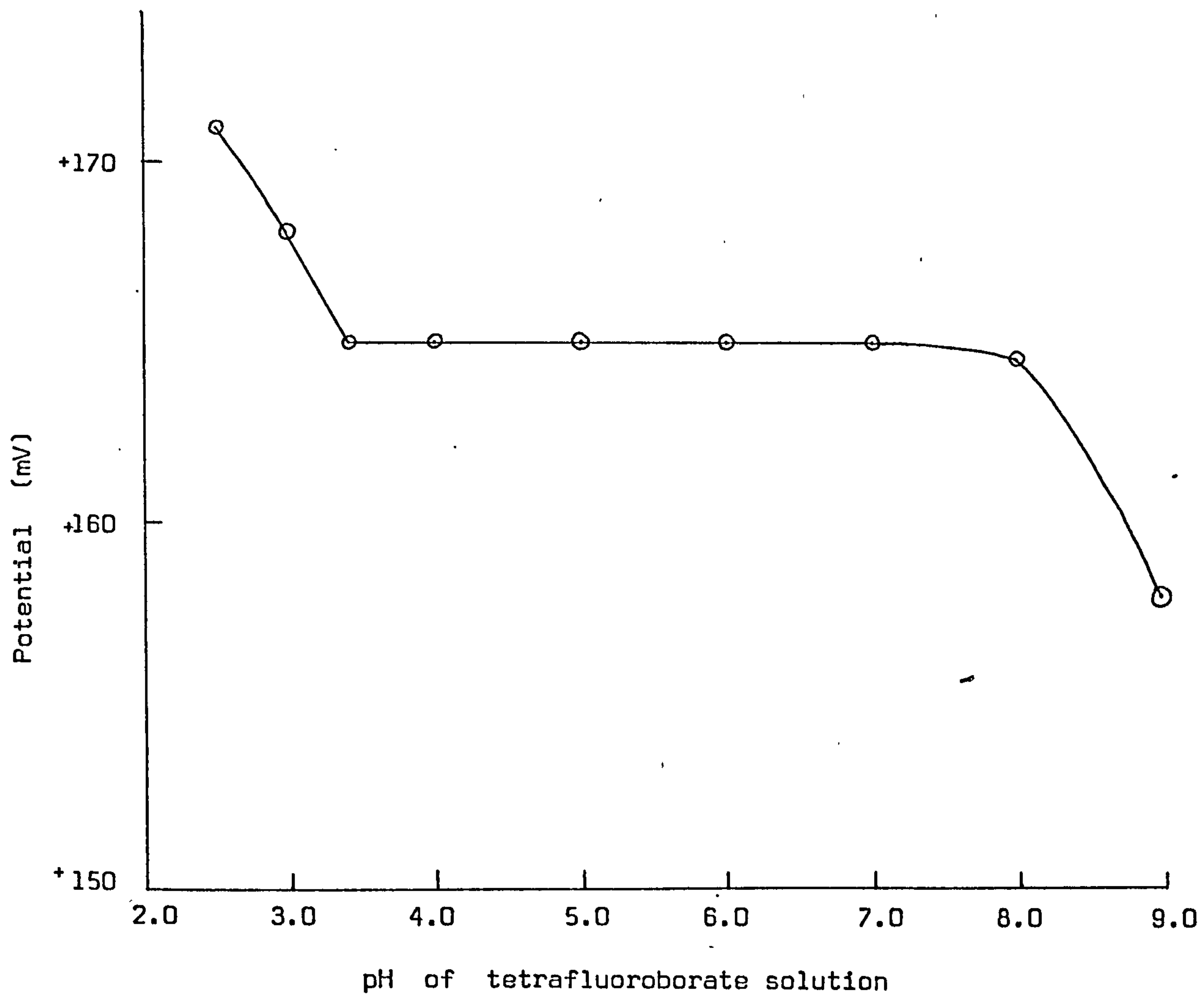

Figure (26)

Due to lack of time, it was not possible to apply this electrode to practical systems; it is at this stage put forward simply as an alternative to other tetrafluoroborate electrodes. Carlson and Paul⁽²³⁰⁾ converted an Orion nitrate-selective electrode into tetrafluoroborate selective electrode by shaking the nitrate ion-exchanger with tetrafluoroborate solution. They used this electrode for the determination of boron in agricultural samples⁽³⁰⁵⁾. Frant⁽⁴⁸⁾ has used a tetrafluoroborate electrode in a variety of fluoroborate baths used in plating. More recently, Wilde⁽³⁰⁶⁾ has determined boron in aluminium oxide-boron carbide using an Orion tetrafluoroborate electrode. It is thought, that the present electrode can be employed in similar applications, provided that the correct working conditions of the electrode are maintained.

Selectivity constants obtained for the present electrode compared favourably with those reported in literature⁽²¹⁰⁾ for the Orion tetrafluoroborate electrode and are given in table 36.

TABLE 36 Selectivity constants of present and Orion liquid state tetrafluoroborate electrode.

Ion	Selectivity constants	
	Present electrode	Orion electrode
Perchlorate	1.6	>1
Iodide	0.012	-
Bicarbonate	0.004	0.004
bromide	0.002	0.04
nitrate	0.002	0.1
acetate	0.0015	0.004
chloride	0.001	0.001
dihydrogenphosphate	10^{-4}	-
fluoride	10^{-4}	9×10^{-5} ⁽²³⁰⁾
borate	4×10^{-5}	-

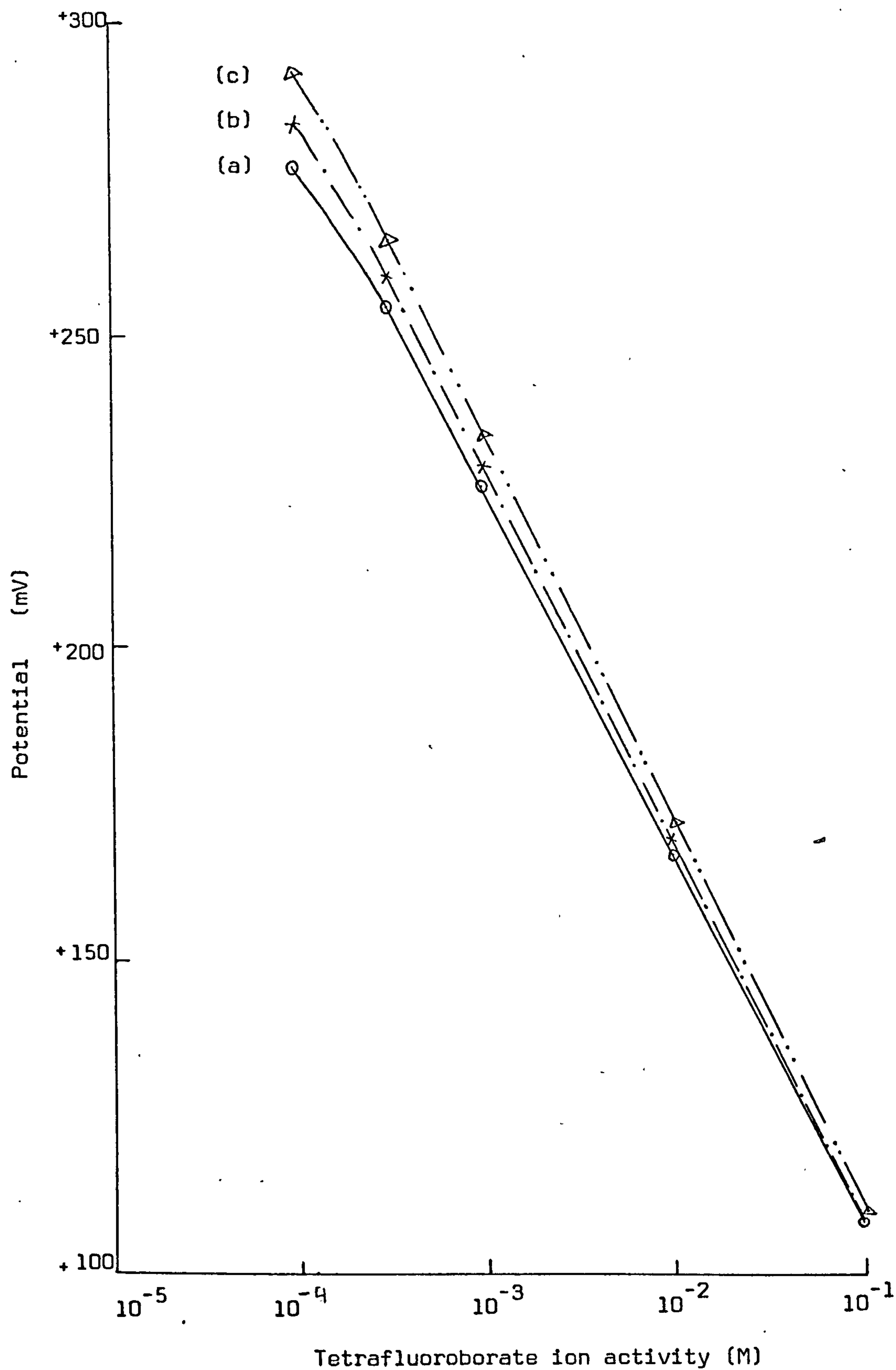

Figure (27)

Electrode response as a function of temperature and ion activity:

(a) 25°C (b) 35°C (c) 45°C

The electrode did not respond to fluoride or borate ions when present separately, and the main interference at high activity was that due to perchlorate.

In the present work Brilliant Green bis(salicylato)borate was also prepared and examined as an ion-exchanger, but the electrode prepared from the salt did not respond to bis(salicylato)borate ions in the sample solutions. This result was disappointing as Vasilevskaya and Lenskaya⁽³⁰⁷⁾ had extracted boron as bis(salicylato)borate with Crystal Violet in an extractive photometric procedure.

APPLICATION OF A SULPHIDE ION SELECTIVE ELECTRODE

A study of the reaction between sulphide and nitroprusside

INTRODUCTION

The reaction of nitroprusside (pentacyanonitrosylferrate(II)) with sulphide ion to give a purple product - The Gmelin reaction⁽³⁰⁸⁾ - is the basis of the classical test for sulphur in organic compounds after their conversion to sulphide by sodium fusion⁽³⁰⁹⁾. The reaction taking place is mainly due to the nitrosyl group which is involved in many reactions with a variety of compounds and ions with the formation of coloured complexes. Reactions of this type involve the modification of the nitrosyl group which remains attached to the central iron atom. The Gmelin reaction is believed⁽³¹⁰⁻³¹²⁾ to be represented by the following equation:

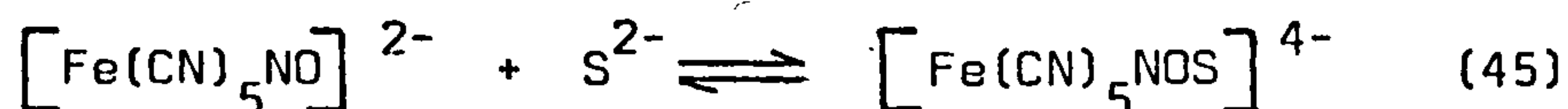

The co-ordinated ion NOS^- appear to occur uniquely in this complex. A recent study had indicated that in the solid the species is dimeric⁽³¹³⁾. The Gmelin reaction is analogous to the reaction of hydroxyl ion with nitroprusside to give the pentacyanonitroferrate(II) ion namely:

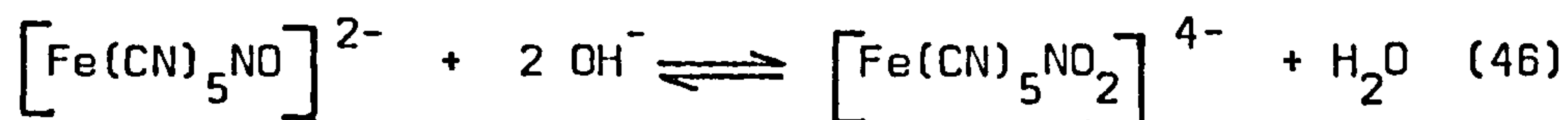

and Boedeker reaction⁽³¹⁵⁾



and also the reaction of nitroprusside with certain thiol compounds:

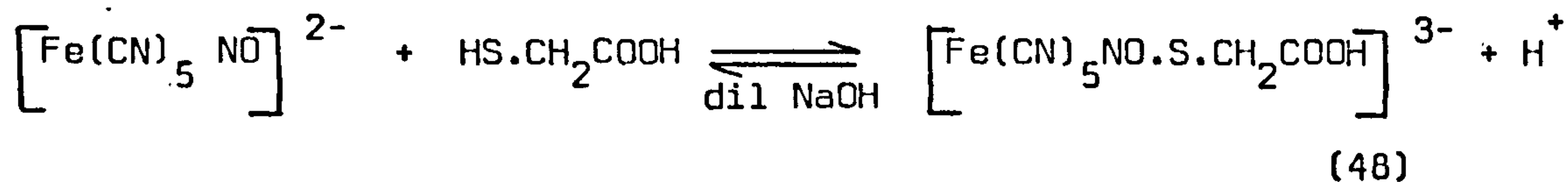

These types of reactions proceed essentially by a nucleophilic attack on the nitroprusside ion.

The Gmelin reaction noted as early as 1848, is widely known because of its use in the detection of sulphide and its resulting extension to the detection of sulphur in organic compounds. That the colour is due to the ion, $[\text{Fe}(\text{CN})_5\text{NOS}]^{4-}$ in which the sulphur atom is directly attached to the nitrogen atom of the nitrosyl group, seems to have been conclusively proved^(310,311) and is given a structure as follows:

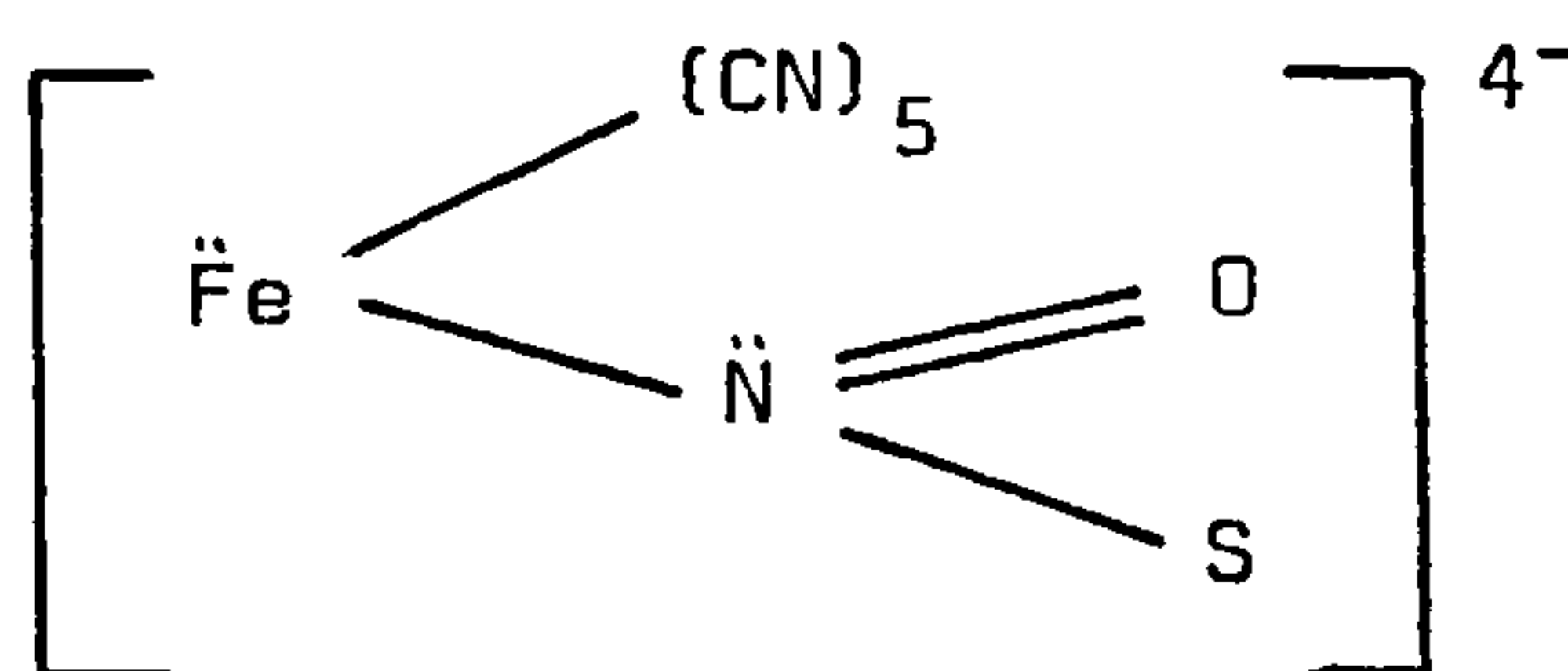

The Gmelin reaction has been used for determination of sulphide in gases by absorbing the gas in solutions of sodium hydroxide⁽³¹⁶⁾ and sodium carbonate⁽³¹⁷⁾. Due to the effect of air the purple colour has not been considered generally to be sufficiently stable for its use in manual colorimetry, although Sewell⁽³¹⁸⁾ has indicated that the purple product is stabilised in formdimethylamide-isopropanol and in dimethylsulphoxide - isopropanol mixtures. Sewell developed a colorimetric procedure for the determination of nitroprusside in cellulose strips. Casapieri, Scott and Simpson⁽³¹⁹⁾ have recommended the use of the reaction in an automated colorimetric procedure for the determination of sulphide in water samples. They indicated that the transient nature of the purple colour would be disadvantageous in a manual procedure. A manual procedure described by Mokhov and Matveeva⁽³²⁰⁾ for the determination of sulphide in air gave non-rectilinear calibration graphs.

Dworzak, Becht, Reitter, and Ruf⁽³²¹⁾ in 1956 used the method of continuous variations to study the reactions of nitroprusside with sulphide and with sulphite. In both cases they indicated that both 1 to 1 and 1 to 2 (nitroprusside: sulphide or sulphite) species were

formed, but in the case of the sulphite reaction the formation of the 1:2 complex was disproved by Moser, Chalmers and Fogg⁽³²²⁾.

The present work was undertaken in order to study the nitroprusside-sulphide reaction by means of a sulphide ion-selective electrode, and to decide whether it is possible to determine sulphide with nitroprusside using this electrode to detect end-points. Scagliarini and Monforte⁽³¹²⁾ in 1934 successfully used a silver-silver sulphide wire electrode to study the reaction potentiometrically. With the recent availability of sulphide membrane electrodes the use of the reaction in potentiometry may become viable and convenient.

Siska and Pungor⁽³²³⁾ have used the sulphide ion-selective electrode to study the precipitation of nitroprusside with silver(I) and mercury(II) ions; these reactions provide means of determining nitroprusside potentiometrically. In the present study, the solution conditions given by Sewell⁽³¹⁸⁾ were found not to give as stable a purple colour as when using solutions 1 M in sodium hydroxide. It was found necessary to use carbonate free sodium hydroxide and de-oxygenated water.

EXPERIMENTAL

Preparation of solutions

All the solutions were prepared in de-oxygenated water. For that purpose tri-distilled water was boiled for about 45 minutes and cooled under oxygen-free nitrogen stream. Solid sodium chloride, silver nitrate, sodium sulphide and sodium nitroprusside used for preparing solutions were of analytical reagent grade. Sodium chloride and silver nitrate were finely powdered and dried by heating in an electric oven for about two hours, maintaining the temperature at 300^oc and 120^oc respectively, the salts were cooled in a desiccator.

The salts were weighed and transferred carefully to prepare 0.10 M solutions. The molarity of silver nitrate solution was confirmed by routine standardisation procedure using standard sodium chloride solution, and potassium chromate as an indicator. As the sulphide ion is stable only in highly alkaline media, 0.1 M sodium sulphide solutions were prepared in 1 M sodium hydroxide (Carbonate free) solutions. A solution of sodium nitroprusside (Fisons Chemical Limited) was prepared to give an exact 0.1 M concentrations, the solution was stored in the dark. Nitroprusside solutions were freshly prepared every second day.

Apparatus assembly

Throughout the potentiometric work, an Orion sulphide-selective electrode (model 94-16) was used in combination with an Orion double junction electrode as reference; the outer compartment of the reference electrode was filled with 1 M sodium hydroxide solution. The sulphide solution was covered tightly with a Perspex lid, and the electrodes were immersed in the solution through holes of their exact diameter in the lid. This operation avoids the direct contact of the solution with air.

Standardisation of sodium sulphide solution

Due to hygroscopic nature of sodium sulphide, it is not possible to prepare solutions of exact molarity, and it was necessary to standardise these solutions. An approximately 0.1 M solution of sodium sulphide (10.0 mls.) prepared in 1 M sodium hydroxide solution was, therefore, standardised by titration with 0.1 M standard silver nitrate solution using Orion solid-state sulphide electrode. The results obtained are given in table 37.

TABLE (37) Potentiometric titration of sulphide with standard silver nitrate.

Amount of AgNO ₃ added (mls)	Potential (mV)	Amount of AgNO ₃ added (mls)	Potential (mV)
0.0	-872.0	19.1	-77.0
1.0	-870.5	19.2	+26.0
4.0	-867.0	19.3	+40.0
9.0	-863.0	20.0	+88.0
16.0	-846.0	21.0	+100.0
18.0	-832.0	23.0	+107.0
19.0	-796.0	25.0	+113.0

The end point was obtained at 19.1 ml 0.1 M silver nitrate standard solution; the molarity of sodium sulphide solution was found to be 0.0955 M.

Potentiometric titration of sodium sulphide with sodium nitroprusside.

As already mentioned, sulphide has been previously determined by sodium nitroprusside, colorimetrically^(316,317) and potentiometrically⁽³¹²⁾. As an alternative method, aliquots of the standard sodium sulphide solution (15 mls) were titrated with 0.1 M sodium nitroprusside solution prepared from analytical reagent grade material using a sulphide selective electrode to detect the end point. The results are given in table 38, figure 28.

TABLE (38) Potentiometric titration of Na_2S (0.0955 M) with 0.1 M sodium nitroprusside.

Amount of $\text{Na}_2[\text{Fe}(\text{CN})_5\text{No}]$ added (mls)	Potential (mV)
0.0	-874.0
1.0	-873.0
3.0	-870.0
5.0	-863.0
7.0	-858.0
9.0	-852.5
11.0	-846.0
13.0	-837.0
14.0	-830.0
14.2	-826.0
14.3	-824.0
14.4	-820.0
14.5	-721.0
14.6	-720.0
14.7	-719.0
15.0	-717.0
16.0	-714.0
17.0	-711.0
18.0	-709.0

Observed end-point is at 14.5 mls of sodium nitroprusside.

Calculated end-point is at 14.55 mls of sodium nitroprusside.

Colorimetric study of the Nitroprusside-sulphide reaction

The method of continuous variations (Job's method)⁽³²⁴⁾ has been widely used in determining the stoichiometry of systems. In this method, the concentration of one species is being increased while that of the other is being decreased, the total added molarities remained fixed. For these solutions it was shown that the 1:1 complex formed

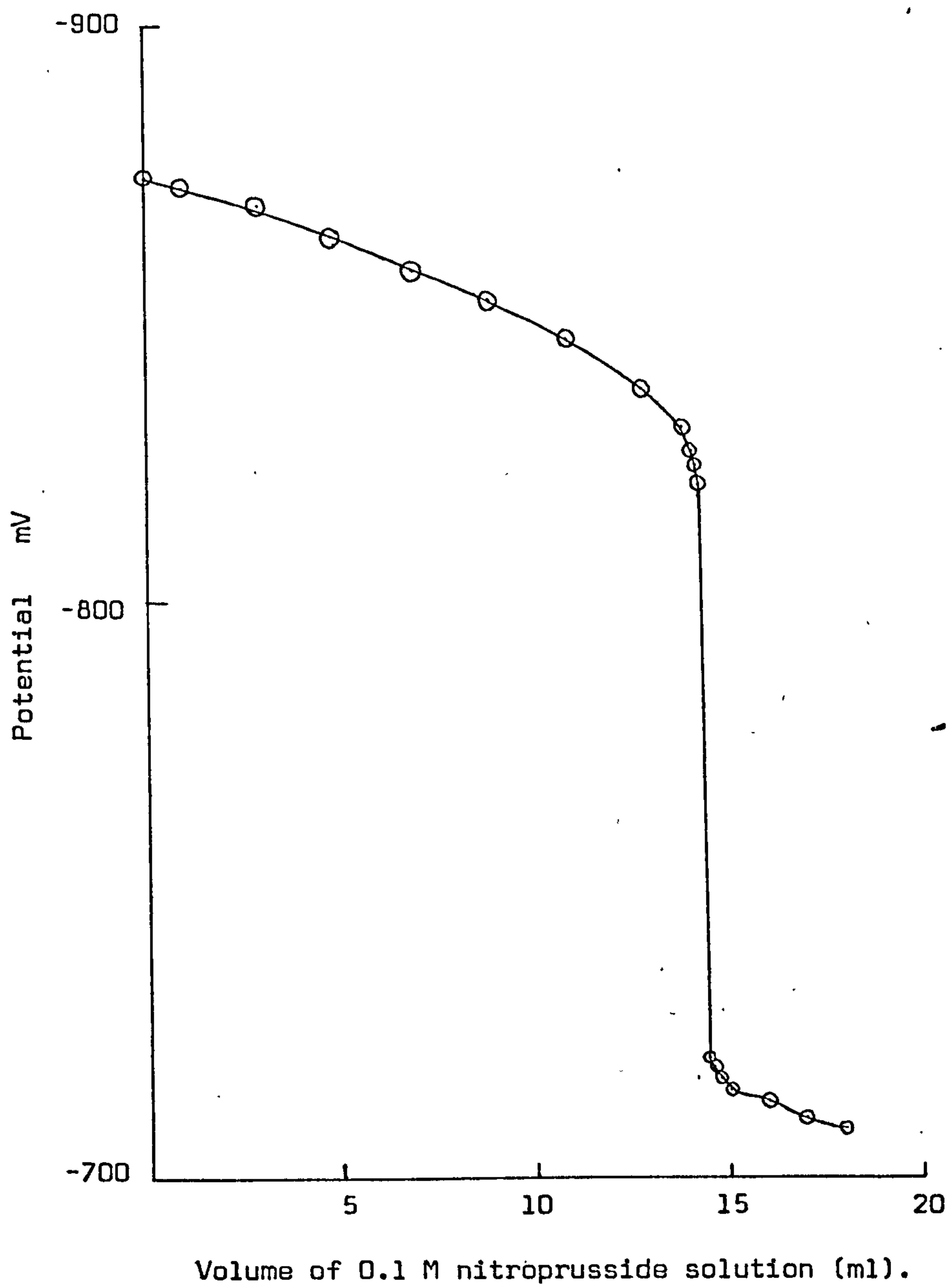

Figure (28)

Potentiometric titration of sodium sulphide with sodium nitroprusside

between pentacyanonitrosylferrate(II) and sulphide ions, was stable. For a compound which contains one molecule of each constituent, and which is formed completely (i.e. very stable), the curve obtained is similar to that in figure 29(a)⁽³¹⁵⁾. If the compound is nearly, but not completely formed from its constituents, then the curve is like that in figure 29(b).

The method of continuous variations was applied colorimetrically using standard solutions of sodium nitroprusside (0.01 M) and sodium sulphide (0.0095 M) in 1 M sodium hydroxide solution. Appropriate aliquots of these solutions were diluted to 100 ml with 1 M sodium hydroxide solution such that the total concentration of sulphide and nitroprusside in the final solutions was 3.8×10^{-4} M in all cases. The maximum absorbance of the purple colour produced was obtained at 542 nm using Unicam Sp 600 and 1 cm. cell. The absorbance of these solutions was measured at this wavelength as soon as possible after preparation and at intervals during the next twenty minutes. In all cases there was a decrease in absorbance after preparation until a lower stable absorbance value was reached after 5 minutes. This value remained constant for further 15 minutes before it decreased again. The optical densities measured are given in table 39 (figure 30).

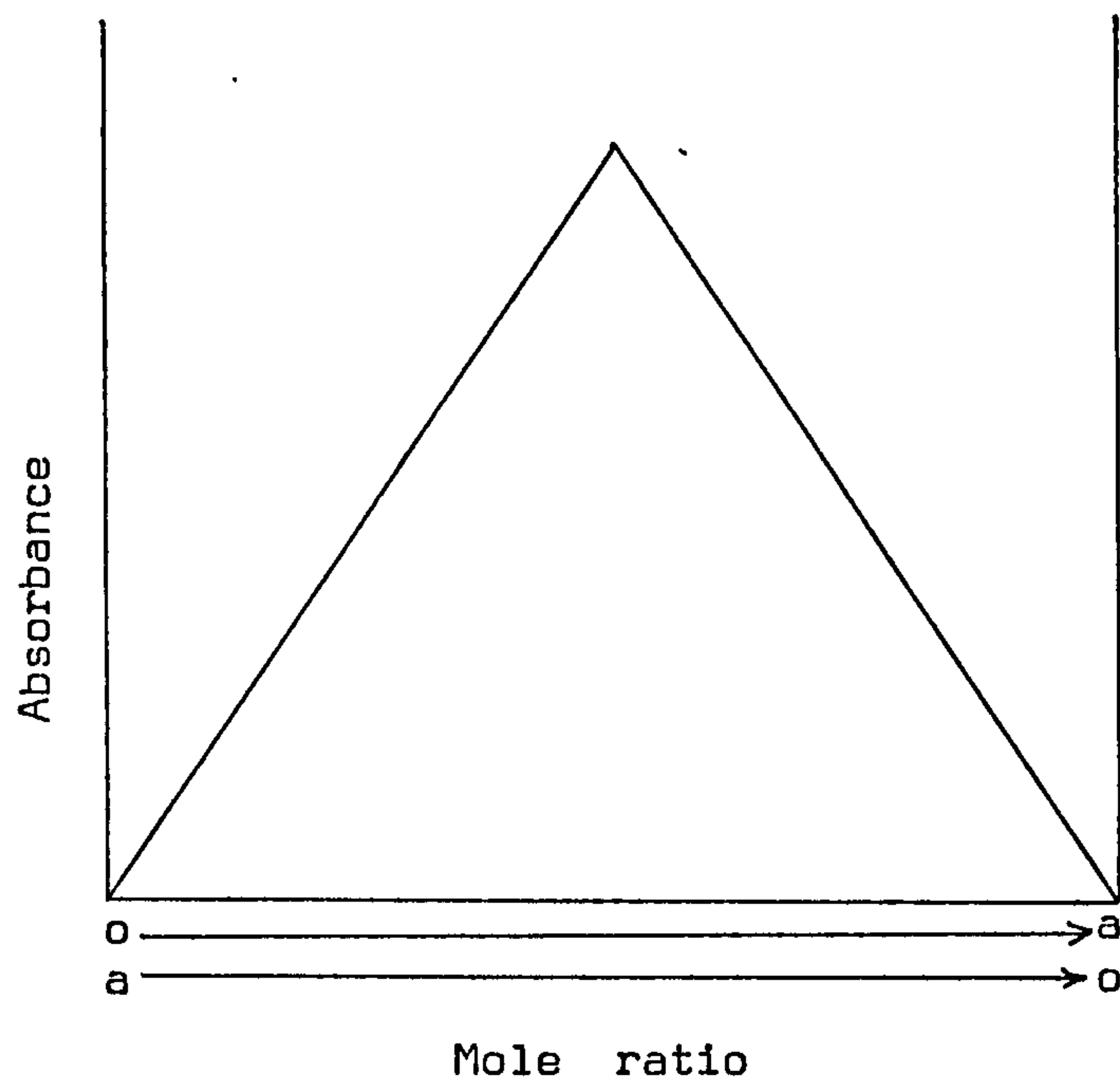

Figure (29 a)

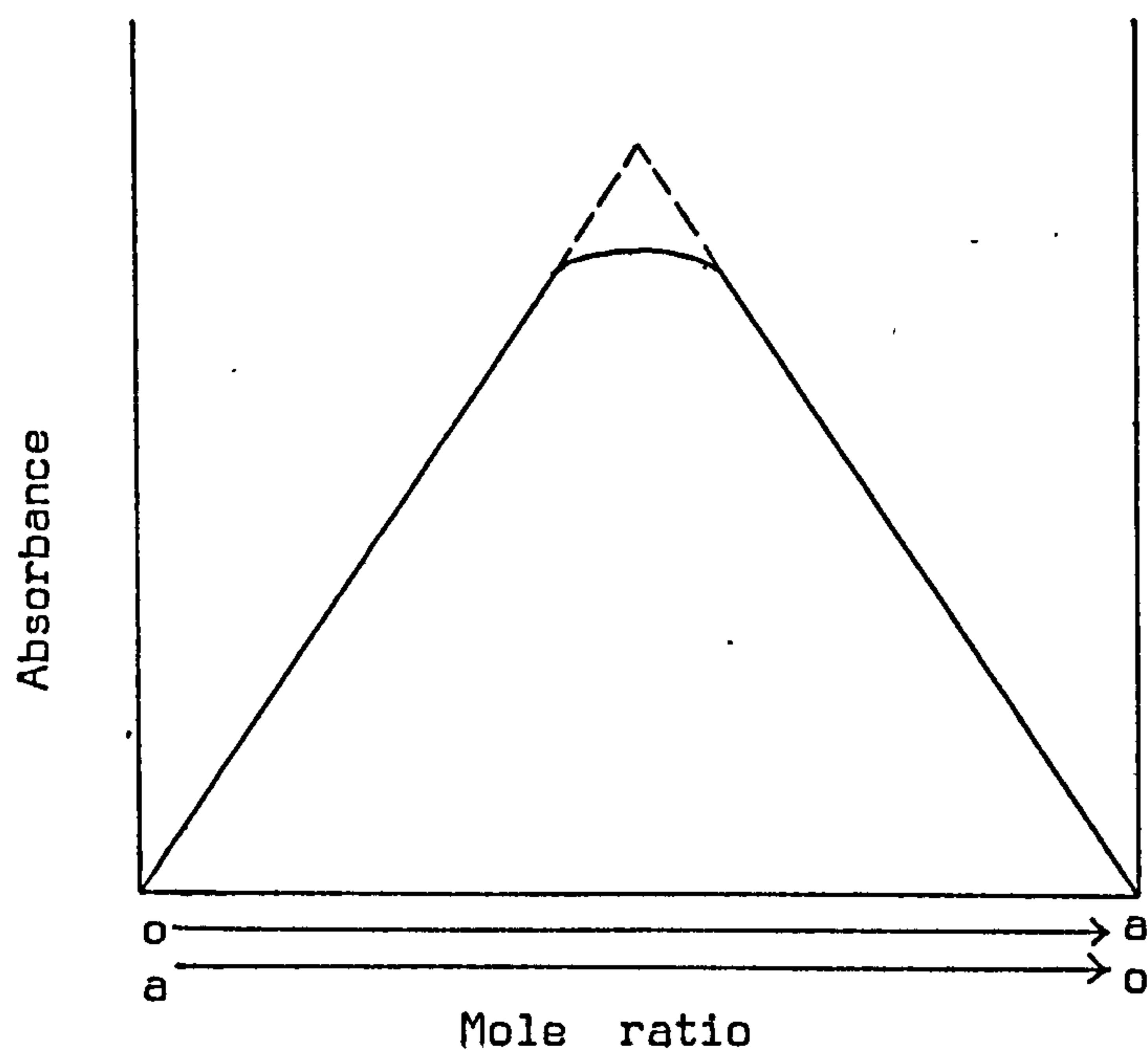

Figure (29 b)

TABLE(39) Continuous variation of sodium sulphide with sodium nitroprusside.

Concentration $M(x 10^{-4})$		Absorbance	
Na_2S	$Na_2 [Fe(CN)_5NO]$	Initial	after 5 minutes
2.8	1.0	0.202	0.172
2.6	1.2	0.234	0.216
2.4	1.4	0.256	0.232
2.2	1.6	0.282	0.260
2.1	1.7	0.291	0.275
2.0	1.8	0.304	0.289
1.9	1.9	0.310	0.298
1.8	2.0	0.295	0.284
1.7	2.1	0.285	0.276
1.6	2.2	0.271	0.262
1.4	2.4	0.244	0.236
1.2	2.6	0.218	0.210
1.0	2.8	0.191	0.185

The results show that maximum absorbance is obtained at 1 to 1 mole ratio of nitroprusside to sulphide which indicates that a 1:1 complex is formed.

The change in absorbance of the complex with time, at 1 to 1 mole ratio of sulphide-nitroprusside is shown in table 40. (figure 31.)

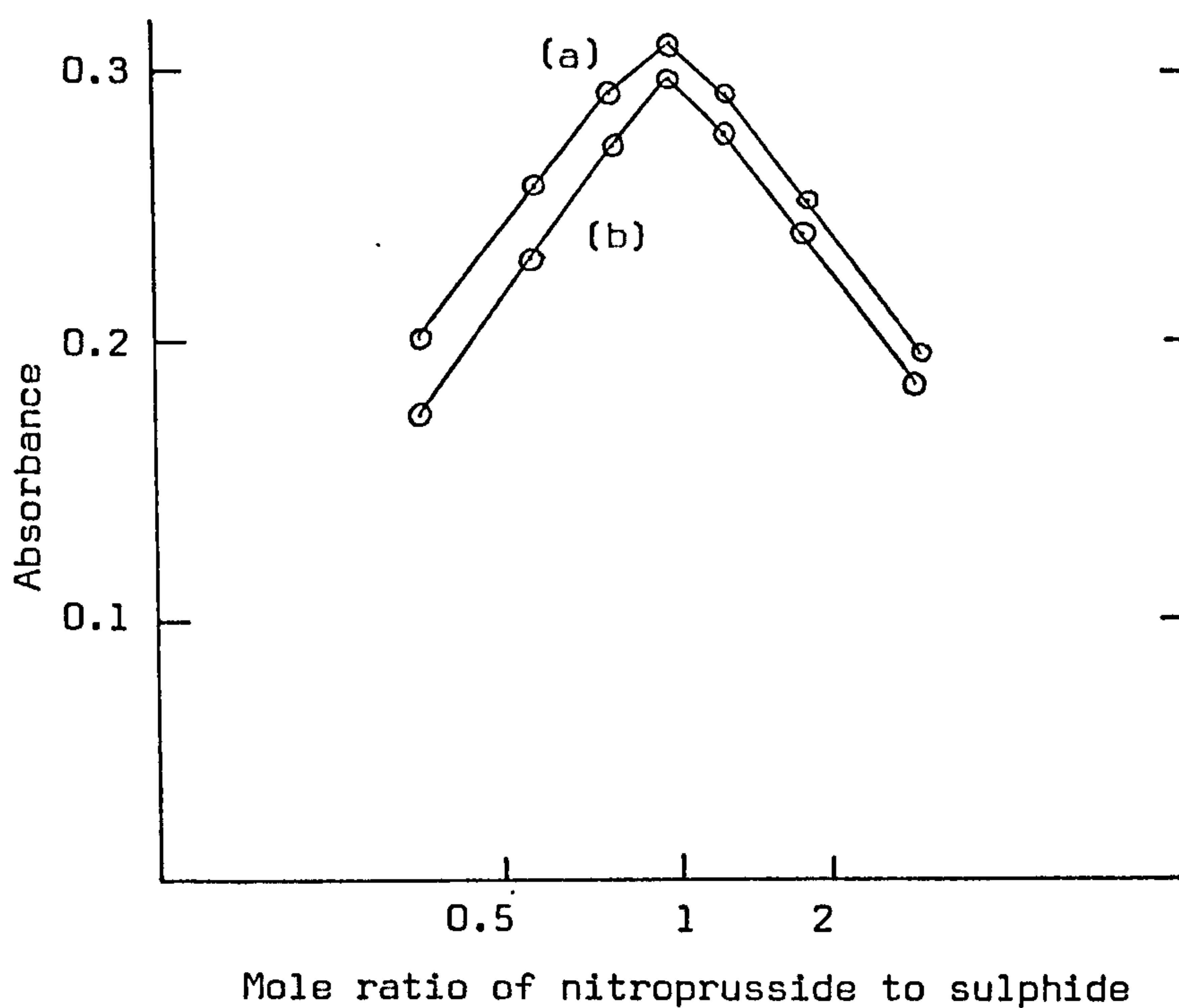

Figure (30)

Continuous variation graph:

(a) Initial (b) after 5 minutes

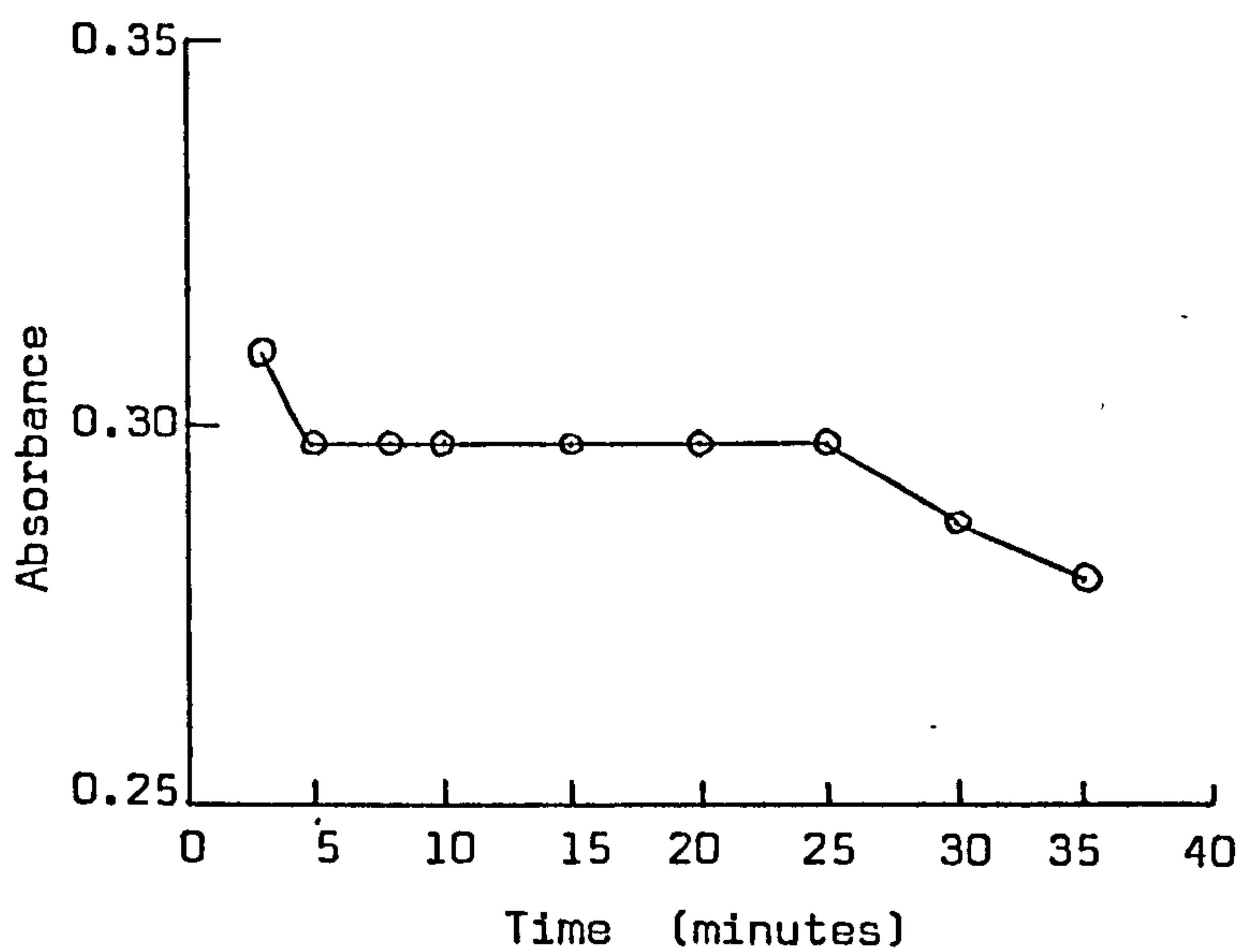

Figure (31)

Change in absorbance with time, at 1:1 mole ratio of sulphide - nitroprusside complex.

TABLE 40 Change in absorbance with time, at 1 to 1 mole ratio of sulphide nitroprusside complex.

Time after preparation (minutes)	Absorbance
3.0	0.310
5.0	0.298
8.0	0.298
10.0	0.298
15.0	0.298
20.0	0.298
25.0	0.298
30.0	0.287
35.0	0.28

A recommended colorimetric procedure for sulphide determinations

From the continuous variations graph it is evident that the method should be suitable for the colorimetric determination of sulphide. There are problems, however, in determining sulphide colorimetrically with nitroprusside as an excess of nitroprusside is converted to the intensely yellow coloured pentacyanonitroferrate(II) ion in concentrated alkaline solutions. Thus even a two fold excess of nitroprusside gives a high blank. Therefore, it is recommended that an amount of nitroprusside equivalent to the maximum amount of sulphide likely to be present be used in obtaining the calibration graph. The absorbance at 542 nm should be read between 5 to 10 minutes after mixing. A typical calibration data using 2 cm. cell is given in table 41 and shown graphically in figure 32.

TABLE (41) Absorbance of nitroprusside (3.8×10^{-4} M) at different concentrations of sulphide.

Concentration of sulphide ($\times 10^{-4}$ M)	Absorbance
0.0	0.110
0.76	0.223
1.52	0.310
2.28	0.416
3.04	0.494
3.80	0.58

DISCUSSION

The reaction of nitroprusside with sulphide is fairly selective under the conditions given here, as the results obtained from potentiometric as well as colorimetric determinations of nitroprusside-sulphide reactions are reproducible. The colour of the nitroprusside-sulphide complex formed by using sulphide solution prepared in 1 M sodium hydroxide was found stable for not less than 15 minutes. The product of the reaction of nitroprusside-sulphite is highly dissociated under these conditions⁽³²²⁾ and sulphite does not interfere. Nitroprusside is reported to react with thiols and with organic compounds having an active methylene group, and these compounds are a possible source of interference.

Because of the initial decrease in colour which occurs immediately after mixing nitroprusside and sulphide solutions it is felt that the potentiometric titration of sulphide with nitroprusside is inherently more accurate and precise than the colorimetric method. The mechanism of deterioration of the colour is unknown, but it is possible that the sulphide ion displaces the nitrosyl group in the nitroprusside ion. An

analogous reaction to this occurs in the case of sulphite where the pentacyanosulphitoferrate(II) ion is formed in solutions of very high sulphite concentration⁽³²²⁾.

Potentiometric titrations were carried out under different conditions, using sodium sulphide and sodium nitroprusside prepared in water and dimethylsulphoxide⁽³¹⁸⁾ as well as in sodium hydroxide and water respectively. Different sets of solutions were used for the titration and it was found that sodium sulphide prepared in 1 M sodium hydroxide when titrated against aqueous nitroprusside solution gave a relatively stable colour and a sharp end point. While this was not so in case of other sets of solutions. A typical titration curve (Figure 28) shows a reasonable potential jump at the end point, and the formation of 1 to 1 sulphide-nitroprusside species, which was confirmed from colorimetric work.

In colorimetric determinations the continuous variations graphs (figure 30) indicate that the initial decrease in absorbance was greater for those solutions containing excess sulphide. Though it is clear that a 1 to 1 species of sulphide-nitroprusside was formed, due to initial instability of the colour the reaction is not particularly suitable for the determination of nitroprusside using excess sulphide. Another recommended procedure was tried also,⁽³¹⁸⁾ but the colour produced in the present work was more stable and reproducible than that obtained on the basis of the other procedure.

The potentiometric titration of sulphide with nitroprusside has a slight advantage over its titration with silver ion in that the appearance of the purple colour confirms that sulphide is being titrated. The potentiometric method is preferable to the colorimetric method as it is suitable for determination of both sulphide and nitroprusside, whereas the colorimetric method is only suitable for sulphide

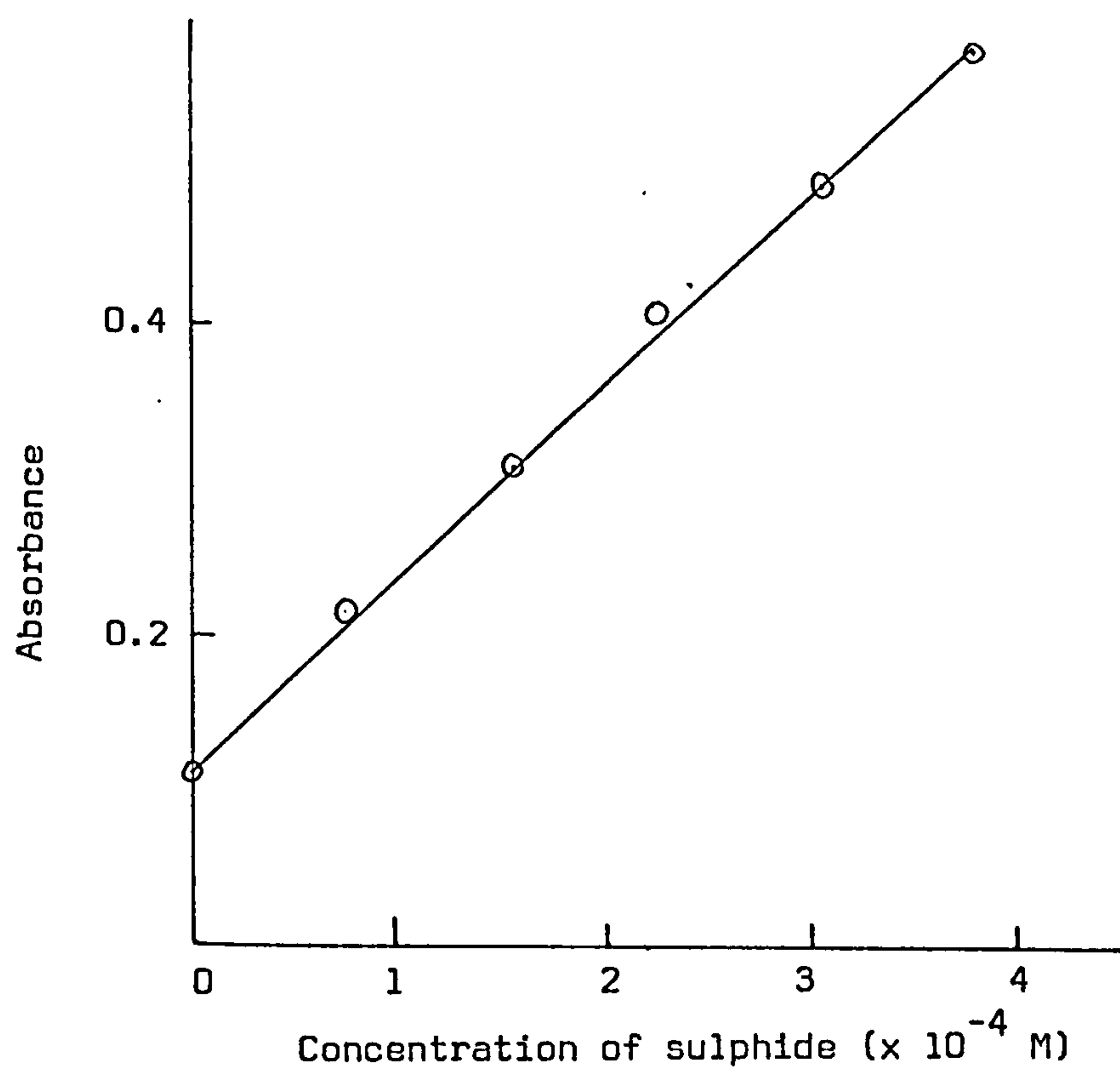

Figure (32)

Calibration graph for the colorimetric determination of sulphide (Nitroprusside concentration = 3.8×10^{-4} M)

determinations and also requires carefully prepared calibration graphs, due to blanks from excess reagent.

Standard solutions of sodium nitroprusside should be prepared frequently and should be protected from light. The addition of E.D.T.A. prevents the formation of Prussian blue⁽³²²⁾ but does not prevent the deterioration of the nitroprusside, and it was found necessary to prepare fresh solutions regularly.

GENERAL DISCUSSION AND SUGGESTIONS FOR FURTHER WORK

The work described in this thesis has been concerned with the development and selection of salts for inclusion in ion-selective electrodes, and with the construction of a new liquid-state electrode assembly.

The silicone-rubber membrane surfactant ion-selective electrode described has been found to respond to detergent cations. The electrode showed a Nernstian response at concentrations below micelle formation and gave good results when used in potentiometric titrations of hexadecyltrimethylammonium and hexadecylpyridinium ions in aqueous solutions with sodium dodecylsulphate, sodium tetraphenylboron, ammonium reineckate, potassium hexacyanoferrate(III) and potassium dichromate. The decrease in potential-concentration slope of the electrodes could possibly be stopped by storing them in dilute solutions of a cationic detergent (e.g. CTAB) instead of water, when not in use. This procedure if successful would increase the working life of electrodes and eliminate the necessity of changing the membranes after a few weeks. In addition it would reduce the amount of calibration necessary when using for the direct potentiometric analysis of samples. For the determination of detergents, the use of electrodes as a sensor in potentiometric titrations is considered preferable to extractive titrations using a colorimetric end point. In the later determinations the end points depend on personal observations of the colour intensities in two layers which can be difficult to separate as well as to judge the colour equality in turbid solutions.

The development of the potassium-selective electrode was an attempt to exploit the use of potassium zinc ferrocyanide as an ion-exchanger. The material when incorporated in silicone rubber and p.v.c. membranes

gave excellent results of 59 mV per decade change in potassium ion activity, over a considerable range of 5×10^{-5} M to 10^{-1} M activity. Though caesium, rubidium and ammonium interfere, as do sodium ions, which are the main practical interference in potassium determinations, the present electrodes are more selective than commercial glass electrodes. It is suggested that other heavy metal ferrocyanides may produce an electrode with higher selectivity for potassium over sodium. Cobalt ferrocyanide may be of some interest, as it is reported⁽²⁸¹⁾ that maximum uptake of alkali metal cations increase in series Fe(III) < Cu < Zn < Ni < Co ferrocyanides. It is also interesting to note that the affinity series for cobalt ferrocyanide is alkali metal cations is in the order of $\text{NH}_4^+ = \text{K}^+ > \text{Rb}^+ > \text{Cs}^+ > \text{Na}^+$; whereas affinity series $\text{Cs}^+ > \text{Rb}^+ > \text{NH}_4^+ > \text{K}^+ > \text{Na}^+$ is reported for zinc ferrocyanide.

In general, information on the possibility of contamination of test solutions from the electrodes is useful. It is of great importance, for example, in on-line use and for biochemical applications in direct contact with blood streams. Contamination is unlikely when glass electrodes are used, but in the case of heterogeneous solid-state electrodes there are very slight chances of contamination through leaching but less so than when liquid-state electrodes are used.

The silicone-rubber membrane electrodes in general take longer to prepare than the liquid-state electrodes. It is advisable to prepare a large sheet of the impregnated membrane so that membrane is readily available for use when necessary. In the work on surfactant electrode, excellent results were obtained with a membrane which was soaked and used five weeks after preparation, and there seems to be no reason why longer storage times should be detrimental.

In the present type of electrodes the use of p.v.c. membranes are considered preferable as they are easy to prepare and to handle. These membranes are flexible and tough in nature. Silicone-rubber membranes are fragile in nature and it needs relatively more care to prepare and to handle. Unless carefully prepared there is some danger that air bubbles remain within the membrane or that pin holes form in the membrane.

The liquid-state ion selective electrodes developed herein are additions to the range of available liquid-state electrodes and are further examples of the use of insoluble basic dye salts in ion-selective electrodes. These electrodes are based on natural rubber membrane saturated with solutions of the basic dye salts in appropriate solvent.

Basic dyes have been widely used for extractive photometric determinations of anions through formation of ion-association complexes. In basic dye colorimetry, the choice of dye and solvent are of great importance; also the correct adjustment of the solution pH is necessary. The dye determines the selectivity of a particular anion and the correct choice of solvent is necessary for complete extraction of the ion-association complex formed. pH adjustment aids in stabilisation of the reactive form of the dye and facilitates complete extraction. These factors must also be considered when basic dye salts are used in ion-selective electrodes. In general, extractability increases with increasing dielectric constant of the solvent. In colorimetry, however, the use of high dielectric constant solvents is limited as the extractability of basic dye reagent can be increased, resulting in high blank absorbances. In the absence of interferences, however, the use of organic solvents of high dielectric constant should not suffer from this disadvantage in ion-selective potentiometry using basic dyes; otherwise such solvents would dissolve ionic compounds which could affect the membrane performance. (325)

On the other hand, the correct choice of the natural rubber for the membrane purpose is of great importance in producing an efficiently working electrode. The membranes have to be saturated with ion-sensor solutions through absorption, thus the rubber must be lightly cross-linked in order to take up the organic solvent solution. It has been observed that some rubbers seem to adsorb the dye only onto the surface and did not make good electroactive membranes. It appears that the dye must be uniformly absorbed into the rubber; electrodes based on such membranes were found to respond very well towards their respective ions. It is convenient if the rubber matrix has the property of quick absorption of the dye salt solution.

Brilliant Green, which is used throughout this work as a cation is preparing complexes with different anions, is pH dependent. It remains in original R^+ form of Brilliant Green between pH 4.5 and 7.0⁽²⁹⁴⁾. The lower pH is that at which the R^+ form is further protonated to RH^{2+} form; the upper pH limit corresponds to the conversion of R^+ form to carbinol base (figure 18). This pH limitation was also the case with present electrodes when membranes were saturated with Brilliant Green salts.

The basic dye liquid state electrodes prepared herein does not need any pre-soaking in aqueous solutions of the corresponding anions, and respond immediately on initial immersion in the test solutions. The response time of these electrodes is usually under one minute; the exact time, however, varies with the activities of the solution used. Steady potentials were obtained more rapidly in more concentrated solutions.

The liquid-state ion selective electrodes under discussion are inexpensive and can be readily prepared, so that they can be used as substitutes for expensive commercial electrodes.

For the determination of zinc down to 10^{-4} M, Orion⁽²¹⁰⁾ have suggested a potentiometric titration using tetraethylenepentamine (T.E.P.A.) as titrant and a cupric solid-state electrode (model 94-29) as a sensing device. The present electrode should be useful for direct determination of zinc as tetrathiocyanatozincate(II), from a calibration graph. As the electrode does not respond to thiocyanate ion, therefore an excess of thiocyanate can be added for complete formation of tetrathiocyanatozincate(II) ion.

A successful use of perchlorate ion-selective electrode in potentiometric titration of perchlorate with tetraphenylarsonium chloride indicates the prospective use of this electrode in perchlorate determinations either by titration or through calibration graphs.

The present tetrafluoroborate electrode can be easily used for applications in which the Orion fluoroborate electrode (model 92-05) has been used; provided conditions of pH are maintained; due to selectivity constant being comparable with Orion electrode⁽²¹⁰⁾ and having a considerable working range.

Russian workers^(287,288) have published a considerable amount of work indicating the possibilities of extraction of various elements in the form of simple anions or complex anions with basic dyes. It is, therefore, suggested that further work should be carried out to investigate the large variety of basic dye ion-association complexes for use in membrane electrodes. Basic dyes which are not pH dependent ought to be particularly useful in the further development of these electrodes. Moreover, the use of such basic dye salts may not be restricted to liquid-state electrodes only. As these compounds are water insoluble, they can easily be used in silicone-rubber and p.v.c. membranes, if optimum conditions of membrane preparation can be established.

The successful development of electrodes described herein clearly indicate a prospective use of natural rubber as an inert matrix for electrode membrane purpose. In the present work we were fortunate in obtaining a commercial grade of natural rubber which was suitable for electrode preparation, but previous experience shows that all grades of rubbers do not behave desirably, due in part at least to the fact that the absorption of dye was not satisfactory.

The application of a sulphide ion-selective electrode in potentiometric titration of sulphide with nitroprusside indicates that such electrodes can successfully be used for determination of both sulphide and nitroprusside under stated conditions. The method described is more specific than any reported⁽³¹⁸⁾ colorimetric method for the same reaction, and is preferable in that it is suitable for both sulphide and nitroprusside; although a colorimetric method for determination of sulphide was also developed.

A P P E N D I X I

SELECTIVITY

The word selectivity for any ion-selective electrode can be defined as the extent to which the presence of any interfering ion affects the response of an electrode towards primary ions. Electrode interferences arise when the electrode responds to ions in the sample solution other than the ions being measured. There is little common agreement in the literature regarding optimal methods for measuring selectivities or determining selectivity ratios of a particular electrode^(4,326,327).

In the case of single crystal membrane electrodes, the electrode response is affected when interfering ions react with a component of the membrane to form new insoluble compounds on the electrode surface. Whereas in case of liquid ion exchange and glass membrane electrodes, interfering ions enter the electrode membrane as the ion being measured.

Selectivities are always presented as their ratio in terms of 'Selectivity Constants', K . This shows the limit to which the presence of interfering ions can be tolerated or the limit where interfering ions will affect the response of the electrode to its ions of interest. According to Moody and Thomas⁽³²⁸⁾, the term selectivity constant can be misleading due to the reasons that, firstly, the selectivity constant value of any two cations (or anions) is dependent on the solution conditions, i.e. it is activity dependent. Secondly, any particular value calculated depends on whether potentials are taken in mixed or separate solutions, as well as on the actual equation employed in subsequent calculations. In any case, for the electrode selective to primary ion, the given value of selectivity constant for interfering ion should be less than one i.e. the smaller the value, the more the

electrode is selective to primary ion. Nevertheless, selectivity constants are extremely useful in deciding whether a given electrode can be used in a particular application.

In a solution containing only primary univalent anion, the potential of a liquid state anion selective electrode is given by,

$$E_1 = E^0 - 2.303 \frac{RT}{F} \log a_{A^-} \quad (49)$$

where a_{A^-} represents the activity of a univalent anion A.

In a solution, if both primary and interfering ions are present then the potential response can be given as,

$$E_2 = E^0 - 2.303 \frac{RT}{F} \log (a_{A^-} + K_{AB} a_{B^-}) \quad (50)$$

where a_{B^-} represents the activity of a univalent anion B, and K_{AB} is the selectivity constant.

Now, in case if the solution contains only interfering anion i.e. $a_{A^-} = 0$, then

$$E_2 = E^0 - 2.303 \frac{RT}{F} \log (K_{AB} a_{B^-})$$

$$\text{or } E_2 = E^0 - 2.303 \frac{RT}{F} \log K_{AB} - 2.303 \frac{RT}{F} \log a_{B^-} \quad (51)$$

In order to find out the potential differences between primary and interfering anions, when both being at the same activity

i.e. $a_{A^-} = a_{B^-}$; subtract equation 51 from equation 49.

$$E_1 - E_2 = -2.303 \frac{RT}{F} \log a_{A^-} + 2.303 \frac{RT}{F} \log K_{AB} + 2.303 \frac{RT}{F} \log a_{B^-} \quad (52)$$

$$\text{or } E_1 - E_2 = 2.303 \frac{RT}{F} \log K_{AB} \quad (53)$$

$$\text{or } \log K_{AB} = \frac{E_1 - E_2}{2.303 \frac{RT}{F}} \quad (54)$$

Thus, the resulting equation gives the formula for calculating selectivity constants from measured potentials of the electrode in primary (E_1) and interfering (E_2) ions.

Now, in another method for separate solutions, when constant potentials are being considered, the selectivity constants are calculated on the basis of activity ratios. In such cases if $E_1 = E_2$, then combining equations 49 and 51.

$$a_{A^-} = K_{AB} a_{B^-} \quad (55)$$

or
$$K_{AB} = \frac{a_{A^-}}{a_{B^-}} \quad (56)$$

BIBLIOGRAPHY

1. G. Eisenman, D.O. Rudin and J.U. Casby, *Science*, 126, 831(1957).
2. B. Lengyel and E. Bulman, *Trans Faraday Soc.*, 30, 461 (1934).
3. C.D. Ray, *Methods in Clinical Chem.*, 1, 108(1970).
4. G.J. Moody and J.D.R. Thomas, *Selective Ion-Sensitive Electrodes*, Merrow Publi. Co., England, 1971.
5. U.K. Patent 1289916, 20th September, (1972).
6. B. Fleet, T.H. Ryan and M.J.D. Brand, *Anal. Chem.*, 46 (1), 12(1974)
7. E. Pungor, K. Toth and J. Havas, *J. Hung. Sci. Instr.*, 3, 2(1965),
8. G.J. Moody, R.B. Oke and J.D.R. Thomas, *Analyst*, 95, 910(1970).
9. A.K. Covington, *Ion-selective electrodes*, NBS Special Publ. 314, Ed. R.A. Durst, (1969), chapter 3.
10. T.S. Light, *Analysis Instruments*, 5, 73(1967).
11. G.A. Rechnitz, *Chem. Eng. News*, 45 (25), 146(1967).
12. A.K. Covington, *Chem. in Brit.*, 5 (9), 388(1969).
13. G.A. Rechnitz, *Anal. Chem.*, 41 (12), 109A(1969).
14. J.M. Riseman, *Industrial Wastes*, 12, Sept/Oct (1970).
15. T.M. Florence, *Proc. Roy. Aust. Chem. Inst.*, 37 (10), 261(1970).
16. W. Simon, H. Wuhrmann, M. Vasak, L.A.R. Pioda, R. Dohner and Z. Stefanac, *Z. Angew. Chem. Int. Ed.*, 9, 455(1970).
17. F.W. Karasek, *Research/Development*, 71, June (1970).
18. R.A. Durst, *Amer. Scientist*, 59 (3), 353(1971).
19. W. Simon, *Pure and Applied Chemistry*, 25, 811(1971).
20. R.J. Simpson, *Effluent and Water treatment J.*, 11 (2), 96(1971).
21. J.T. Pearson, *Chem. Drugg.*, 195, 218(1971).
22. D.E. Collis, *Kent Technical reviews*, 10, 17(Oct. 1973).
23. R.P. Buck, *Anal. Chem.*, 44 (5), 270R(1972).
24. R.P. Buck, *Anal. Chem.*, 46 (5), 28R(1974).
25. G.J. Moody and J.D.R. Thomas, *Talanta*, 19, 623(1972).

26. J. Koryta, *Anal. Chim., Acta*, 61, 329(1972).
27. J. Tenygl, MTP. *Int. Review of Science, Anal.Chem., Part I*, Ed. T.S. West, chapter 4, Butterworth Uni. press. (1973).
28. A.K. Covington, *Critical review in analytical chem.*, 3, 355, (Jan 1974).
29. G.J. Moody, R.B. Oke, and J.D.R. Thomas, *Lab.Pract.*, 18, 941(1969).
30. G. Mattock, *Chimia*, 21 (6), 209(1967).
31. W. Thompson, *Kent Technical Review*, 9, 16(May 1972).
32. M.S. Frant, J.W. Ross and J.M. Riseman, *Amer. Lab.*, 1, 14(1969).
33. J. Bagg, *Proc. Roy. Aust. Chem. Inst.*, 38 (4), 521(1972).
34. E. Pungor, *Anal. Chem.*, 39 (13), 28A(1967).
35. E. Pungor, and K. Toth, *Analyst (London)*, 95, 625(1970).
36. E. Pungor, and K. Toth, *Pure and Appl. Chem.*, 31 (4), 521(1972).
37. A.B. Davies, U.K. Atomic Energy Authority, AWRE Report No. 046/71.
38. G. Eisenman, *Anal. Chem.*, 40 (2), 310(1968).
39. R.A. Durst, "Ion-Selective Electrodes" NBS publication 314(1969).
40. J.B. Andelman, *J. Water pollution Control Federation*, 40 (11), 1844(1968).
41. J.B. Andelman, *Ind. Water Engg.*, 6 (12), 57(1969).
42. J.M. Riseman, *Amer. Lab.*, 1, 32(July 1969).
43. T.B. Warner, *Marine Tech. Soc.*, 2, 270(1970).
44. S.J. Weber, *Int. Lab.*, 28, Sept/Oct(1971).
45. P.J. LeBlanc and J.F. Sliwinski, *Int. Lab.*, 25, Sept./Oct.(1973).
46. L.R. Beals, *Anal. Instr.*, 7, 74(1969).
47. T.S. Light, *Ind. Water Engg.*, 6 (9), 33(1969).
48. M.S. Frant, *Plating*, 58, 686(1971).
49. W.C. Purdy, *Methods in Clinical Chem.*, 1, 82(1969).
50. B. Fleet, A.W.Y. Ho and G.P. Bound, *Proc. Soc. Anal. Chem.*, 10, 257(1973).
51. K.S.A. Gnanasckaran and K.C. Narasimham, *Transactions of SAEST*, 4, 33(1969).

52. J. Havas and J. Kiszal, Proc. conf. of appl. phys. chem., 1, 553(1971).
53. I. Kraszani and F. Fa'bry, Proc. conf. of appl. phys. chem., 1, 645(1971).
54. M. Cremer, Z. Biol, 47, 562(1906).
55. F. Haber and Z.Klemensiewicz, Z. Physik. Chem., 67, 385(1909).
56. D.A. MacInnes and M. Dole, J. Am. Chem. Soc., 52, 29(1930).
57. J.O. Isard, "Glass electrodes for hydrogen and other cations" Principles and practice, Ed. G. Eisenman, Publ. Marcel Dekker Inc., New York (1967) P.88.
58. British Patent, 1025542, April(1966).
59. British Patent 1018055, Jan.(1966).
60. British Patent, 1260065, Jan.(1972).
61. G.G. Guilbault and J.G. Montalvo, J. Am. Chem. Soc., 91, 2164(1969).
62. G.G. Guilbault and J.G. Montalvo, J. Am. Chem. Soc., 92 (8), 2533(1970).
63. G.G. Guilbault and J.G. Montalvo, Anal. letters, 2, 283(1969).
64. G.G. Guilbault, R.K. Smith and J.G. Montalvo, Anal. Chem., 41, 600(1969).
65. G.G. Guilbault and E. Hrabánková, Anal. Chim. Acta., 52, 287(1970).
66. G.G. Guilbault, Pure and Appl. Chem., 25, 727(1971).
67. G.G. Guilbault and E. Hrabánková, Anal. letters, 3, 53(1970).
68. E. Hrabánková and G.G. Guilbault, Anal. Chem., 42 (14), 1779(1970).
69. G.G. Guilbault and E. Hrabánková, Anal. Chim. Acta., 56, 285(1971).
70. G.G. Guilbault and F.R. Shu, Anal. Chim. Acta., 56, 333(1971).
71. K.L. Grochet and J.G. Montalvo, Anal. Chim. Acta., 66, 259(1973).
72. R.G. Bates, "Determination of pH", Theory and practice, publ. John Wiley and Sons, New York, (1963) P.309.
73. G. Eisenman, "Glass Electrodes for hydrogen and other cations". Publ. Marcel Dekker Inc., New York (1967) chapter 9.
74. Z. Stefanac and W. Simon, Anal. letters, 1 (2), 1(1967).
75. G.A. Rechnitz and Zui-Feng Lin, Anal. Chem., 39 (12), 1406(1967).
76. G.A. Rechnitz, S.A. Katzand, and S.B. Zamochnick, Anal. Chem., 35, 1322(1963).

77. G.A. Rechnitz and S.B. Zamochnick, *Talanta*, 11, 1061(1964).
78. W.P. Gurney, Beckman Reprint R - 6212.
79. R.N. Khuri, "Ion Selective electrodes" NBS publication 314, Ed. R.A. Durst (1969) Chapter 8.
80. J.S. Annino, *J. Soc. Clin. Chem.*, 13, 227(1967).
81. J.T. Pearson and C.M. Elstob, *J. Pharm. and Pharmacology*, 22, 73(1970).
82. J.A.M. Hinkle, *Nature*, 184, 1257(1959).
83. M.S. Friedman, "Glass electrodes for hydrogen and other cations". Ed. G. Eisenman, Publ. Marcel Dekker, New York (1967). Chapter 16.
84. R.A. Durst and J.K. Taylor, *Anal. Chem.*, 39 (12), 1483(1967).
85. British Patent, 131574, Oct.(1968).
86. British Patent, 1150698, April(1969).
87. G.M. Farren, paper presented at A.C.A.S. conference, March(1974), Coleman Instruments pre-print T-235-370 .
88. G.A. Rechnitz, G.A. Fricke and M.S. Mohan, *Anal. Chem.*, 44 (6), 1098(1972).
89. M.S. Frant and J.W. Ross, *Science*, 154, 1553(1966).
90. G.J. Moody, R.B. Oke and J.D.R. Thomas, *Lab. Practice*, 18 (10), 1056(1969).
91. J.J. Lingane, *Anal. Chem.*, 39, 881(1967).
92. J. Buffle, N. Parthasarathy and W. Haerdi, *Anal. Chim. Acta.*, 68 , 253(1974).
93. J.J. Lingane, *Anal. Chem.*, 40, 1935(1968).
94. M.S. Frant and J.W. Ross, *Anal. Chem.*, 40, 1169(1968).
95. Orion application bulletin No. 4 (Form 4 AB 94-09/074), (1970).
96. British Patent 1131574, Oct.(1968).
97. G.M. Farren, *Ger. offen.*, 2101339 (Cl.G 01n) Sept.(1971).
98. N.E. Vanderborgh, *Talanta*, 15, 1009(1968).
99. A.Aziz and S.J. Lyle, *Anal. Chim. Acta.*, 47, 49(1969).
100. B. Elgquist, *J. Inorg. Nucl. Chem.*, 32, 937(1970).
101. S.L. Grassino and D.N. Hume, *J. Inorg. Nucl. Chem.*, 33, 421(1971).

102. D.E. Collis and A.A. Diggins, *Water treat. and Examin.*, 18, 192(1969).
103. T. Anfält and D. Jagner, *Anal. Chim Acta.*, 53, 13(1971).
104. B.L. Ingram, *Anal. Chem.*, 42 (14), 1825(1970).
105. B.L. Ingram and May Irving, *U.S. Geol. survey prof. paper*, 750-B, B 110(1971).
106. C.W. Louw and J.E. Richards, *Analyst*, 97, 334 (1972).
107. J. Tusl, *Clin. Chim. Acta.*, 27, 216(1970).
108. J. Tusl, *Anal. Chem.*, 44 (9), 1693(1972).
109. W.P. Farren and N.A. Shane, *J. Food. Sci.*, 34, 317(1969).
110. P. Hotz, H.R. Mühlemann and A. Schait, *Hel. Odont. Acta* 14 (4), 26(1970).
111. R. Aasenden, E.C. Moreno and F. Bruderold, *Archs. Oral, Biol.*, 17 (5), 315(1972).
112. B.C. Jones, J.E. Heveran and B.Z. Senkowski, *J. Pharm. Sci.*, 60 (7), 1036(1971).
113. A.M. Pochomis and F.D. Griffith, *Amer. Ind. Hyg. Assoc. J.*, 32 (8), 557(1971).
114. T. Gyoerkoes, D.A. White and R.L. Luthy, *J. of Metals*, 22 (12), 29A(1970).
115. R.L. Baker, *Anal. Chem.*, 44 (7), 1326(1972).
116. E.J. Bushee, D.K. Grissom and D.R. Smith, *J. Dent, Child*, 38 (4), 279(1971).
117. J.N. Wilson and C.Z. Marczewski, *Anal. Chem.*, 45 (14), 2409(1973).
118. T.B. Warner and D.J. Bressan, *Anal. Chim. Acta.*, 63, 165(1973).
119. Orion application bulletin No. 12, Form 12AB94 - 16/071(1969).
120. T.M. Hseu and G.A. Rechnitz, *Anal. Chem.*, 40, 1054(1968).
121. R. Naumann and C. Weber, *Z. Anal. Chem.*, 251, 111(1971).
122. W. Krijgsman, J.F. Mansveld and B. Griepink, *Z. Anal. Chem.*, 249, 368(1970).
123. N.J. Bethea and R.M. Bethea, *Anal. Chim. Acta.*, 61 (2), 311(1972).
124. M.S. Frant, J.W. Ross and J.H. Riseman, *Anal. Chem.*, 44 (10), 2227(1972).
125. J.H. Riseman, *Am. Lab.*, 4 (12), 63(1972).

126. L.C. Gruen and B.S. Harrap, *Anal. Bio. chem.*, 42, 377(1971).
127. F. Peter and R. Rosset, *Anal. Chim. Acta.*; 64(3), 397(1973)
128. B.S. Harrap and L.C. Gruen, *Anal. Bio. chem.*, 42, 398(1971).
129. D.W. Gruenwedel and R.K. Patnaik, *J. Agr. Food. chem.* 19
(4), 775(1971).
130. G.P. Morie, *Tabacco Sci.*, 107, 34(1971).
131. G. Spaeth, H.J. Niefuid and M. Martina, *M Schr. Brau*, 25 (4),
91(1972).
132. J.W. Ross, "Ion-Selective Electrodes". NBS Publication 314. Ed.
R.A. Durst, (1969) chapter 2.
133. H. Hirata, K. Higashiyama and K. Data, *Anal. Chim. Acta*, 51,
209(1970).
134. H. Hirata and K. Higashiyama, *Anal. Chim. Acta*, 54, 415(1971).
135. H. Hirata and K. Higashiyama, *Anal. Chim. Acta*, 57, 476(1971).
136. G.A. Rechnitz and N.C. Kenny, *Anal. letters*, 2, 395(1969).
137. J.W. Ross and M.S. Frant, *Anal. Chem.*, 41, 967(1969).
138. C. Harzdorf, *Z. Anal. Chem.*, 262 (3), 167(1972).
139. M. Mascini, *Analyst*, 98 (1166), 325(1973).
140. British Patent, 872486, July(1961).
141. I.M. Kolthoff and E.B. Sanders, *J. Am. Chem. Soc.*, 59, 416(1937).
142. British patent, 1150698, April(1969).
143. G.A. Rechnitz and R.A. Llenado, *Anal. Chem.*, 43 (11), 1457(1971).
144. R.A. Llenado and G.A. Rechnitz, *Anal. Chem.*, 44 (3), 468(1972).
145. M. Mascini and A. Liberti, *Anal. Chim. Acta*, 68 (1), 77(1974).
146. P.W. Alexander and G.A. Rechnitz, *Analyst*, 46, 860(1974).
147. M. Sharp and G. Johansson, *Anal. Chim. Acta*, 54, 13(1971).
148. M. Sharp, *Anal. Chim. Acta*, 59, 137(1972).
149. M. Sharp, *Anal. Chim. Acta*, 61, 99(1972).
150. E. Pungor, J. Havas and K. Toth, *Instr. and control system*,
38, 105(1965).
151. A.G.M. Macdonald and K. Toth, *Anal. Chim. Acta*, 41, 99(1968).
152. M.R. Wyllie and H.W. Patnode, *J. Phys. Chem.*, 54, 204(1950).
153. H.J.C. Tendeloo and A. Krips, *Rec. Trav. Chim.*, 76, 703 and 946(1957).

154. E. Pungor and E. Hollös - Roksinyi, Acta. Chim. Hung., 27, 63(1961).
155. E. Pungor, J. Havas and K. Toth, Acta. Chim. Hung., 41, 329(1964).
156. E. Pungor, E. Schmidt and K. Toth, Proc. IMEKO Symposium on Electro-chemical sensors, Vescprem, Hungary (1968), P. 121-134.
157. G.A. Rechnitz, M.R. Kresz and S.B. Zamochnick, Anal. Chem., 38, 973(1966).
158. G.A. Rechnitz and M.R. Kresz, Anal. Chem., 38, 1787(1966).
159. E.A. Materova, G.P. Grinberg and M.M. Evstifeeva, Z. Anal. Khim., 24 (6), 821(1969).
160. E.B. Buchanan and J.L. Seago, Anal. Chem., 40 (3), 517(1968).
161. E. Pungor, K. Toth and J. Pick, Anal. Chim. Acta, 61 (2), 169(1972).
162. H. Hirata and K. Date, Anal. chem., 43 (2), 279(1971).
163. U. Olavi Lukkari, E.J. Hakoila and H.K. Lukkari, Anal. chem. fenn. 45 (5 - 6), 182(1972).
164. H. Hirata and K. Date, Bull. Chem. Soc. Japan, 46 (5), 1468(1973).
165. J.Pick, K. Toth, E. Pungor, M. Vasak and W. Simon, Anal. Chim. Acta., 64 (3), 477(1973).
166. G.G. Guilbault and G. Nagy, Anal. Chem., 45 (2), 417(1973).
167. G.G. Guilbault, G. Nagy and S.S. Kuan, Anal. Chim. Acta, 67 (1), 195(1973).
168. A. Shatkay, Anal. Chem., 39 1056(1967).
169. R. Bloch, A. Shatkay and H.A. Saroff, Biophys. J., 7, 865(1967).
170. A. Ansaldi and S.I. Epstein, Anal. Chem., 45 (3), 595(1973).
171. J.E.W. Davies, G.J. Moody and J.D.R. Thomas, Analyst, 97, 87(1972).
172. J.E.W. Davies, G.J. Moody, W.M. Price and J.D.R. Thomas, Lab. Pract., 22 (1), 20(1973).
173. D.L. Manning, J.R. Stokely and D.W. Magouyrk, Anal. Chem., 46, 1116(1974).
174. G.H. Griffiths, G.J. Moody and J.D.R. Thomas, Analyst, 97, 420(1972).
175. O. Ryba and J. Petranek, J. Electroanal. Chem. and Interf. electrochem., 44, 425(1973).
176. G. Baum and M. Lynn, Anal. Chim. Acta, 65 (2), 393(1973).
177. G. Baum, M. Lynn and F.B. Ward, Anal. Chim. Acta, 65 (2), 385(1973).

178. M.D. Smith, M.A. Grenshaw and J. Greyson, *Anal. Chem.*, 45 (9), 1782(1973).
179. M. Mascini and A. Liberti, *Anal. Chim. Acta*, 47, 339(1969).
180. M. Mascini and A. Liberti, *Anal. Chim. Acta*, 51, 231(1970).
181. J.C. Vanloo, *Anal. Chim. Acta*, 54 (1), 23(1971).
182. M. Mascini and A. Liberti, *Anal. Chim. Acta*, 53, 202(1971).
183. M. Mascini and A. Liberti, *Anal. Chim. Acta*, 60 (2), 405(1972).
184. M. Mascini and A. Liberti, *Anal. Chim. Acta*, 62 (1), 29(1972).
185. M. Mascini and A. Liberti, *Anal. Chim. Acta*, 64 (1), 63(1973).
186. C.N. Wang, P.J. Kinlen, D.A. Schoeller and C.O. Huber, *Anal. Chem.*, 44 (7), 1152(1972).
187. S. Masaric and E.A.M.F. Dahmen, *Anal. Chim. Acta*, 64 (3), 431(1973).
188. H. Hirata and K. Date, *Talanta*, 17, 883(1970).
189. R.W. Cattrall and H. Freiser, *Anal. Chem.*, 43 (13), 883(1971).
190. H. James, G. Carmack and H. Freiser, *Anal. Chem.*, 44 (4), 856(1972).
191. J. Havas, E. Papp and E. Pungor, *Anal. Chim. Hung.*, 58, 9(1968).
192. G. György, L. Andre, E. Stechli and E. Pungor, *Anal. Chim. Acta*, 46, 318(1969).
193. M.K. Papay, V.P. Izvekov, K. Toth, and E. Pungor, *Anal. Chim. Acta*, 69, 173(1974).
194. Radiometer Information bulletin on Růžička Selectrodes, Kit type 3000 - 3004.
195. J. Růžička, C.G. Lamm and J.C. Tjell, *Anal. Chim. Acta*, 62 (1), 15(1972).
196. British Patent, 1150698, April(1969).
197. J. Růžička and C.G. Lamm, *Anal. Chim. Acta*, 54 (1), 1(1971).
198. E.H. Hansen, C.G. Lamm and J. Růžička, *Anal. Chim. Acta.*, 59 (3), 403(1972).
199. J. Růžička and E.H. Hansen, *Anal. Chim. Acta*, 63 (1), 115(1973).
200. J. Růžička, E.H. Hansen and J.C. Tjell, *Anal. Chim. Acta*, 67, 155(1973).
201. U. Fiedler and J. Růžička, *Anal. Chim. Acta*, 67, 179(1973).
202. British Patent, 1100186, Jan.(1968).

203. British Patent, 1262019, Feb.(1972).
204. G.J. Moody and J.D.R. Thomas, quoted U.S. Patent No. 3438886, April, (1969).
205. British Patent, 1284476, Aug.(1972).
206. British Patent, 1289916, Sept.(1972).
207. British Patent, 1197264, July(1970).
208. British Patent, 1208533, Oct.(1970).
209. J.W. Ross, Science, 156, 1378(1967).
210. Orion Research Analytical method guide, 6th Ed., (1973).
211. Beckman Selective Ion Electrode Bulletin, 7145-A.
212. Corning - EEL Scientific Instruments, pH and Ion-Selective Electrodes.
213. F.A. Schultz, A.J. Pedersen, C.A. Mask and R.P. Buck, Science, 162, 267(1968).
214. B. Fleet and G.A. Rechnitz, Anal. Chem., 42, 690(1970).
215. B. Seamond, J. Towfighi and D.A. Aravan, Clin. Chem., 18 (2), 155(1972).
216. Z. Stefanac and W. Simon, Chimia, 20, 436(1966); Mikrochem. J., 12, 125(1967).
217. L.A.R. Pioda and W. Simon, Chimia, 23, 72(1969).
218. L.A.R. Pioda, V. Stankova and W. Simon, Anal. letters, 2, 665(1969).
219. M.S. Frant and J.W. Ross(Jr), Science, 167, 987(1970).
220. Philips analytical equipment bulletin, Oct.(1970).
221. J.L. Walker, Anal. Chem., 43, 89A(1971).
222. O. Kadem, M. Furmanski, E. Leobal, S. Gordon and R. Bloch, Israel J. Chem., 7 (Proceedings), 191(1969).
223. R.N. Khuri and H.J. Jacque, J. Appl. physiol., 32 (2), 419(1972).
224. S. Lal and G.D. Christian, Anal. letters, 3 (1), 11(1970).
225. T. Anfält and D. Jagner, Anal. Chim. Acta, 66 (1), 152(1973).
226. R.P. Scholer and W. Simon, Chimia, 24, 372(1970).
227. N. Ishibashi and H. Kohara, Anal. letters, 4, 785(1971).
228. M. Sharp, Anal. Chim. Acta, 65 (2), 405(1973).

229. M. Sharp, Anal. Chim. Acta, 62 (2), 385(1972).
230. R.M. Carlson and I.L. Paul, Anal. Chem., 40, 1292(1968).
231. A.L. Grekovick, E.A. Materova and V.E. Yurinskaya, Zh. analit. Khim., 27 (6), 1218(1972).
232. G.A. Qureshi and J. Lindquist, Anal. Chim. Acta, 67 (1), 243(1973).
233. A. Hulanicki, R. Lewan-dowski and M. Maj, Anal. Chim. Acta, 69, 409(1974).
234. J. Růžicka and J.C. Tjell, Anal. Chim. Acta, 51, 1(1970).
235. R.J. Levins, Anal. Chem., 44 (8), 1544(1972).
236. A.V. Gordeov and A.Y. Syrchenkov, Trudy, mosk, Khim. tekhnol. Inst., 69, 140 (1972).
237. A. Burdin, J. Mesplede and M. Porthault, C.r. hebd. Seanc. Acad. Sci. Paris. C., 276 (1), 65(1973).
238. M. Matsui and H. Freiser, Anal. letters, 3 (4), 161(1970).
239. R. Scholer and W. Simon, Helv. Chim. Acta, 55(5), 1801(1972).
240. S. Lal and G.D. Christian, Anal. Chim. Acta, 52 41(1970).
241. G.G. Guilbault and P.J. Brignac, Anal. Chim. Acta, 56, 139(1971).
242. G. Backstig, Anal. letters, 4 (11), 793(1971).
243. N. Ishibashi, H. Kohara and K. Horinouchi, Talanta, 20 (9), 867(1973).
244. C. Gavach and P. Seta, Anal. Chim. Acta, 50, 407(1970).
245. C. Gavach and C. Bertrand, Anal. Chim. Acta, 55, 385(1971).
246. B.J. Birch and D.E. Clarke, Anal. Chim. Acta, 61, 159 (1972).
247. B.J. Birch and D.E. Clarke, Anal. Chim. Acta, 67, 387(1973).
248. B.J. Birch and D.E. Clarke, Anal. Chim. Acta, 69, 473(1974).
249. J.W. Ross, J.H. Riseman and J.A. Krueger, Pure and Appl. Chem. 36, 473(1974).
250. J. Růžicka and E.H. Hansen, Anal. Chim. Acta, 69, 129(1974).
251. Orion Newsletter, Specific ion electrode, Vol. 5 (2), 7(1973).
252. Orion Research Specification Instruction manual for Ammonia electrode, model 95-10 form 1M95 - 10/275 and DS-95-10/1711.
253. Orion Newsletter, Specific ion electrode, 4 (5 and 6), 17(1972)
254. EIL - Information guide on Laboratory electrodes, 1st July(1973).

255. K.W. Maring and R.W. Steinmann, Chem. Rundschau, 27 (43), 699(1973).
256. J.M. Bremner and M.A. Tabatabai, Comm. Soil. Sci. Plant. Analysis, 3 (2), 159(1972).
257. P.J. Le Blanc and J.F. Sliwinski, Am. Lab., 5 (7), 51(1973).
258. L. Vandervenne and J. Dudewater, Report No. 352, centre Belge d' Etude et de Documentation des Eaux, (1973).
259. W.L. Benwart, M.A. Tabalabai and J.M. Bremer, Comm. Soil sci. plant analysis, 3 (6), 449(1972).
260. E. Busenberg and C.V. Clemency, Clays and clay minerals, 21, 213(1973).
261. T.C. Woodis (Jr.) and J.M. Cummings (Jr), J. Assoc. Offic. Agr. Chemists, 56 (2), 373(1973).
262. Orion research information form DS95 - 64/73.
263. J. Tengyl, quoted R.W. Stow, R.F. Baer and B.F. Randall, Arch. phys. Med. Rehabil, 38, 646(1957).
264. A. Brian and M. Andrew, Lab. News, No. 68, 10(1974).
265. P.F. Gibson, Lab. Equipment digest, 12(1), 76(1974).
266. A.M. James, Practical Physical Chemistry. Publ. J.A. Churchill Ltd., London (1961) P.61.
267. A. Davidsohn and B.M. Milwidsky, "Synthetic detergents", Publ. Leonard Hill, London, (1972).
268. W.B. Smith, Analyst, 84, 77(1959).
269. T. Barr, J. Oliver and W.V. Stubbings, J. Soc. Chem. Ind., 67, 45(1948).
270. W.I. Stephen, Mfg. chemists, 27, 102(1956).
271. J.T. Cross, Cationic surfactants, Ed. Jungerman Erric Marcel Dekker Inc. N.Y., 419, (1970).
272. H.Y. Lew, J. Am. Oil, Chem. Soc., 49 (11), 65(1972).
273. J. Kiba, S. Kambara, J. Electroanalyt. chem., 44 (1), 129(1973).
274. J.R. Cottrell, Paper presented to IUPAC , International Symposium on selective-ion Electrodes, Cardiff, April(1973).
275. J.H. Jones, J. Assoc. Offic. Agr. Chem., 28, 398(1945).
276. K. Szterjopulsoz, Proc. Anal. chem. confr. 3rd., 2, 185(1970).
277. J.J. Hefferren and C. Dietz, J. Pharm. sci., 50, (61), 535(1961).

278. K. Thoma, E. Ullmann and P. Loss, *Pharmazie*, 18, 414(1963).
279. J.B. Wilson, *J. Assoc. Offic. Agr. Chem.*, 35, 455(1952).
280. T. Uno, K. Miyajima and H. Tsukatani, *Yakugaku, Zasshi.*, 80, 153(1960).
281. V. Pekárek and V. Vasely', *Talanta*, 19, 1245(1972).
282. V.V. Pusharev, L.D. Skrylev and V.F. Bagretsov, *Z. Prikl. Khim.*, 33, 81(1960).
283. A.G. Fogg, G.R. Reynolds, *Anal. Chim. Acta*, 32, 582(1965).
284. G.B. Seifer, *Zh. Neorgan. Khim.*, 7, 1208(1962); *C.A.*, 57, 6849e(1962).
285. S. Kawamura, K. Kurotaki, H. Kuraku and M. Izawa, *J. Chromatog.*, 26, 557(1967).
286. R.A. Robinson and R.H. Stokes, "Electrolyte Solutions". second Ed. Butterworths, London (1959) P.230.
287. I.A. Blyum and N.N. Pavlova, *Zav. Lab.*, 29 (12), 1407(1963).
288. I.A. Blyum and L.I. Oparina, *Zav. Lab.*, 36 (8), 897(1970).
289. A.G. Fogg, C. Burgess and D. Thorburn Burns, *Talanta*, 18, 1175(1971).
290. L. Ducret and H. Maurel, *Anal. Chim. Acta*, 21, 74(1959).
291. V.I. Kuznetsov, *Uspekhi, Khimii.*, 23 (6), 654(1954).
292. I.A. Blyum and N.N. Pavlova, *Zhur. Analit. Khimii*, 20 (9), 898(1965).
293. J.R. Entwistle and T.J. Hayes, Abstract of Papers, IUPAC, International symposium on selective Ion-selective electrodes, Cardiff, U.K. April(1973), paper 17.
294. A.G. Fogg, C. Burgess and D. Thorburn Burns, *Analyst*, 95, 1012(1970).
295. Z.Slovák and M. Příbyl, *Collection Czech. chem. comm.* 31, 1742(1966); *chem. Abs.*, 14, 4571(1967).
296. R.N. Adams, *Anal. Chem.*, 30, 1576(1958).
297. R.J. Baczuk and R.J. Dubois, *Anal. Chem.*, 40, 685(1968).
298. M.J. Smith and S.E. Manahan, *Anal. Chim. Acta*, 48, 315(1969).
299. T.M. Hsue and G.A. Rechnitz, *Anal. letters*, 1, 629(1968).
300. G.O. Kerr and G.R.E.C. Gregory, *Analyst*, 94, 1036(1969).
301. A.K. Babko and P.V. Marchenko, *Zav. Lab.*, 26, 1202(1960).
302. L. Ducret, *Anal. Chim. Acta*, 17, 213(1957).

303. L. Pasztor, J.D. Bode and Q. Fernando, *Anal. Chem.*, 32, 277(1960).
304. F. Vernon and J.M. Williams, *Anal. Chim. Acta*, 51, 533(1970).
305. R.M. Carlson and J.L. Paul, *Soil science*, 108, 266(1969).
306. H.E. Wilde, *Anal. Chem.*, 45, 1526(1973).
307. A.E. Vasilevskaya and L.K. Lenskaya, *Zh. Anal. Khim.*, 20, 747(1965).
308. "Gmelins Handbuck der Anorganischen chemie", Vol. 59B, P.737, Verlag chemie GMBH, Berlin,(1932).
309. H. Kral, *Z. Anal. Chem.*, 36, 696(1897).
310. G. Scagliarini and P. Pratesi, *Atti. Accad. Naz. Lincei, Rend.*, 13, 199(1931).
311. G. Scagliarini and F. Gentile, *ibid*, 17, 398(1933).
312. G. Scagliarini and F. Monforte, *ibid*, 20, 41(1934).
313. E.J. Baran and A. Müller, *Angew. Chem. Intern. Ed. Engl.*, 8, 890(1969).
314. H.E. Williams, "Cyanogen Compounds", Edward Arnold London, (1948).
315. A.G. Fogg, Ph.D. Thesis, University of Aberdeen, (1961).
316. W.A. Currie, Jr. *The Gas World*, 2, 553(1933).
317. J. Bell and W.K. Hall, *J. Soc. Chem. Ind.*, Jan 31, 89(1936).
318. B.A. Sewell, *Analyst*, 90, 507(1965).
319. P. Casapieri, R. Scott and E.A. Simpson, *Anal. Chim. Acta*, 45, 547(1969).
320. L.A. Mokhov and S.A. Matveeva, *Lab. Delo*, 8, 44(1962).
321. R. Dworzak, K.H. Becht, L. Reitter and E. Ruff, *Z. Anorg. Allgem. chem.*, 285, 143(1956).
322. W. Moser, R.A. Chalmers and A.G. Fogg, *J. Inorg. Nucl. Chem.*, 27, 831(1965).
323. E. Siska and E. Pungor, *Talanta*, 19, 715(1972).
324. P. Job, *Ann. Chim.*, 9, 113(1928).
325. T. Moeller, *Inorganic chemistry*, Publ. John Wiley and Sons Inc. New York, (1961), P. 343.
326. Orion Research Incorporated, *Newsletter*, 1 (5), 29(1969).
327. K. Srinivasan and G.A. Rechnitz, *Anal. Chem.*, 41 (10), 1203(1969).
328. G.J. Moody and J.D.R. Thomas, *Talanta*, 18, 1251(1971).