

This item was submitted to Loughborough's Institutional Repository (<https://dspace.lboro.ac.uk/>) by the author and is made available under the following Creative Commons Licence conditions.



CC creative commons  
COMMONS DEED

**Attribution-NonCommercial-NoDerivs 2.5**

**You are free:**

- to copy, distribute, display, and perform the work

**Under the following conditions:**

 **Attribution.** You must attribute the work in the manner specified by the author or licensor.

 **Noncommercial.** You may not use this work for commercial purposes.

 **No Derivative Works.** You may not alter, transform, or build upon this work.

- For any reuse or distribution, you must make clear to others the license terms of this work.
- Any of these conditions can be waived if you get permission from the copyright holder.

**Your fair use and other rights are in no way affected by the above.**

This is a human-readable summary of the [Legal Code \(the full license\)](#).

[Disclaimer](#) 

For the full text of this licence, please go to:  
<http://creativecommons.org/licenses/by-nc-nd/2.5/>

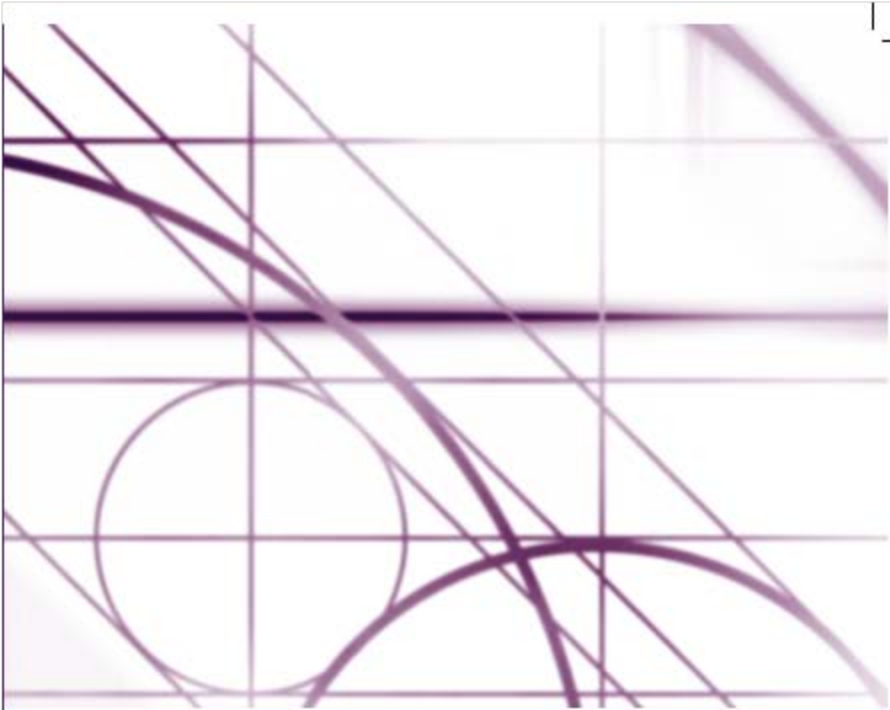

# **Value Enhanced Collaborative Working (VECW)**

*Udityasinh Gohil*



# **Value Enhanced Collaborative Working (VECW)**

---

**Udityasinh Gohil**

---

---

**ServQ Ltd.  
Berry Smith Corporate  
Haywood House  
Dumfries Place  
Cardiff  
CF10 3GA**

**Centre for Innovative Construction Engineering  
(CICE)  
Department of Civil & Building Engineering  
Loughborough University  
Loughborough  
Leics, LE11 3TU**



# **VALUE ENHANCED COLLABORATIVE WORKING (VECW)**

By  
Udityasinh Gohil

A Dissertation Thesis submitted in partial fulfilment of the requirements for the award  
of Engineering Doctorate (EngD) of Loughborough University

[June 2011]

**© by Udityasinh Gohil [2011]**

ServQ Ltd.  
Berry Smith Corporate  
Haywood House  
Dumfries Place  
Cardiff  
CF10 3GA

Centre for Innovative Construction Engineering  
(CICE)  
Department of Civil & Building Engineering  
Loughborough University  
Loughborough  
Leics, LE11 3TU

*“Knowing is not good enough; we must apply.  
Willing is not enough; we must do.”*

- Johann Wolfgang von Goethe

*Dedicated to my parents, Subhadra and Dharmavirsinh Gohil, for all their love and  
sacrifices*

## **ACKNOWLEDGEMENTS**

A doctorate research is not an independent taking. It requires the support of a diverse range of people to eventually achieve the doctorate. I would like to acknowledge ServQ for giving me a chance to carry out this research project. In particular I would like to express my sincere gratitude for ServQ directors Ian Watson and Andy Crossley, for providing me with all the help and support they could provide and encourage me to complete this research project. I am also indebted to all the Associates, Clients and Strategic Partners of ServQ to give me their time for my research project.

My academic supervisors, Prof. Patricia Carrillo, Dr. Kirti Ruikar and Prof. Chimay Anumba, were a fountain of knowledge always ready to share with me. They showed deep understanding and gave me the required motivation at each and every stage of my research. They gave me the virtue of patience and challenged my ideas at each stage to help give my research a rigorous depth. I am also greatly thankful for the assistance provided by CICE support staff, throughout the research.

There are no words to describe the patience showed by my wife, dad, mom and my brother, Brij. They have always been behind me on this journey. Especially my wife, Ulrike, for being the biggest motivation of my life. I would also like to thank all my friends and family for putting up with my mood swings in the last years of my research. Special mention needs to go to Zainab, Harshal, Keyur, Nag and the LUSCC cricketers. Lastly, I am thankful to God for giving me a chance to attain a higher level of knowledge and learning.





## ABSTRACT

In recent years, the service industry has been made aware of the advantages of risk sharing and inter-firm collaborations. In the current turbulent business environment, a large proportion of Small and Medium sized Enterprises (SME) firms rely on collaboration and partnering with other businesses. The value of such collaboration is highly enhanced by pooling resources to help exploit complementarities between the collaborating businesses and significantly increasing performance and management. Many studies have been conducted on the determinants of collaboration success or failures. However, authors have suggested further research to provide a framework to cover the factors responsible for enhanced value within collaborative working. In particular, the susceptibility of SMEs to successfully collaborate is significantly less than that of large organisations. Hence this was the focus of the current study.

The research was focused on establishing the value enhancement of collaborative working within ServQ's, the sponsoring organisation's, collaborative environment. The main aim of this research project is 'To investigate the potential of Value-Enhanced Collaborative Working (VECW) in an SME management advisory firm'. The aim was achieved with the help of the development of a VECW framework based on the issues faced by ServQ's collaborative environment. To achieve this aim, an inductive research approach was adopted; this was facilitated by literature reviews and research methods such as semi-structured interviews, focus groups and scenario planning. This was to ensure that the project was an applied research based on the sound foundations of available theories on collaborative working.

The research was initiated with a preliminary case study of the sponsoring organisation to better understand it. This period of initial investigation entailed learning more about the organisation's management and working culture. Parallel to the initial case study, a literature review helped establish a definition of Value Enhanced Collaborative Working (VECW) as well as a conceptual VECW framework.

Three key factors were identified in the conceptual VECW framework; these were considered as three separate but equally important branches that together will create a sustainable long-term collaborative working environment. The first factor identified was the People factor; the main output from this was the development of a Collaboration Charter. The Process factor developed a business process model for ServQ while the Tools factor was established through scenario planning. The output of this research was a development of a VECW framework. The research work progressed chronologically by first developing a conceptual VECW framework followed by the development of each of the People, Process and Tool factors in further detail with the help of mechanisms such as Collaboration Charter and business process models. Eventually the framework recommended how all these three factors together enhance the value of collaboration in ServQ. These outputs established the mechanisms to balance all the three factors within ServQ resulting in development of a sustainable collaboration environment.

The research has contributed to knowledge by providing a VECW framework in an industrial setting that can be replicated in similar organisations with required changes. In addition, it

complements the wide array of literature pertaining to Collaborative Working, SMEs, services organisations and Value.

**KEY WORDS**

Collaborative Working, Value, SME, Service organisation

## **PREFACE**

The research work was conducted in order to fulfil the minimum requirements of an Engineering Doctorate (EngD) degree carried out at the Centre for Innovative and Collaborative Engineering (CICE) at Loughborough University, Leicestershire, UK. The research programme was based in an industrial setting, sponsored by ServQ, a small management advisory firm and supported by CICE. The programme is funded by Engineering and Physical Sciences Research Council (EPSRC).

The EngD is an alternative programme to traditional PhD to provide the Research Engineer (RE) with additional managerial and business skills in addition to the deep technical understanding of their research subject. The programme is designed to make it more vocationally oriented to help graduates to progress rapidly to positions at senior management level.

The research programme requires the researcher to conduct research and publish the outcomes of the research as reviewed academic journals and conference papers. In addition, the programme includes the writing of technical reports for the organisation as well as the final thesis writing. This thesis discourse is supported by three journal papers located in Appendices A-C. The main discourse provides an overall synopsis of the research work undertaken, while the papers provide an exhaustive perspective of the research components. It is requested that the discourse is read in conjunction with the published papers.



## **USED ACRONYMS / ABBREVIATIONS**

ABC –	Activity Based Costing
BPR –	Business Process Re-engineering
CICE –	Centre for Innovative Construction Engineering
CSFs –	Critical Success Factors
CW –	Collaborative Working
EngD –	Engineering Doctorate
IDEF0 –	Integration DEFinition Language 0
ISO –	International Standards Organisation
IP –	Intellectual Property
IT –	Information Technology
IW –	Implications Wheel
PBSO –	Project Based Service Organisations
PC –	Partnership Continuum
RE –	Research Engineer
SME –	Small and Medium size Enterprises
SP –	Strategic Partners
TC –	Target Costing
VECW –	Value Enhanced Collaborative Working
VM –	Value Management



---

## TABLE OF CONTENT

<b>Acknowledgements .....</b>	<b>i</b>
<b>Abstract.....</b>	<b>iii</b>
<b>Key Words .....</b>	<b>iv</b>
<b>Preface.....</b>	<b>v</b>
<b>Used Acronyms / Abbreviations .....</b>	<b>vii</b>
<b>Table of Content.....</b>	<b>ix</b>
<b>Table of Figures.....</b>	<b>xiii</b>
<b>Table of Tables .....</b>	<b>xv</b>
<b>List of Papers.....</b>	<b>xvi</b>
<b>1 Introduction .....</b>	<b>1</b>
1.1 Introduction .....	1
1.2 The Research Domain .....	1
1.3 The Research Context.....	1
1.4 The Industrial Sponsor.....	2
1.5 Aim of Research .....	3
1.6 Research Objective .....	3
1.7 Justification of the Research.....	4
1.8 Summary.....	4
<b>2 Literature review .....</b>	<b>7</b>
2.1 Introduction .....	7
2.2 Collaboration .....	7
2.2.1 Collaboration for Strategic Advantage .....	9
2.3 Collaboration Working within SMEs .....	9
2.3.1 Benefits of Collaborative Working.....	10
2.3.2 Issues in Collaborative Working.....	11
2.4 Value within Collaborative Working .....	13
2.5 Factors Affecting Collaborative Working in SMEs .....	16
2.5.1 People Factor .....	16
2.5.2 Process Factor .....	18
2.5.3 Tools Factor .....	18
2.6 Management of Collaborative Working.....	20
2.7 Summary.....	20
<b>3 Research Methodology .....</b>	<b>21</b>
3.1 Overview .....	21
3.2 Research Methodologies.....	21
3.2.1 Deductive Approach .....	23
3.2.2 Inductive Approach.....	23
3.2.3 Deductive - Inductive Continuum.....	23
3.3 Data Collection Methods/Tools.....	24
3.4 Methodological Background .....	26
3.5 Adopted Research Methodology .....	27

3.5.1	Understand the Foundations of CW and Value with Respect to SME Service Industry .....	27
3.5.2	Investigate Patterns of CW within ServQ to Identify Areas of Process Improvement.....	28
3.5.3	Further Investigate the Identified Concern Areas for Process Improvement in Isolation.....	28
3.5.4	To Develop and Evaluate a Comprehensive Framework to Enhance CW29	
3.5.5	To Identify the Managerial Implications of the Research .....	30
3.6	Summary.....	31
<b>4</b>	<b>Research Undertaken And Findings.....</b>	<b>33</b>
4.1	Introduction .....	33
4.2	Establish a VECW Definition.....	36
4.2.1	Determine the Requirements of VECW .....	36
4.2.2	Identify VECW Factors to Develop a Conceptual Framework .....	37
4.2.3	Summary of VECW Conceptual Framework .....	38
4.3	People Factor .....	39
4.3.1	Approach for Aligning the People Factor in VECW .....	39
4.3.2	Examination of Existing Partnership Agreements.....	39
4.3.3	Adoption of a New Collaboration Charter.....	40
4.3.4	Findings of People Factor .....	41
4.4	Process Factor.....	42
4.4.1	Rationale Behind IDEF0 for Process Modelling .....	43
4.4.2	A Business Process Model.....	44
4.4.3	Example Node – Node A2 .....	44
4.4.4	Effects of Changes Modelled in IDEF0.....	47
4.4.5	Findings of Process Factor.....	47
4.5	Tools Factor.....	48
4.5.1	Investigation of Synergy Needs Between Tools.....	48
4.5.2	Selections of Projects and Scenarios.....	50
4.5.3	Findings of Tools Factor .....	51
<b>5</b>	<b>Evaluation .....</b>	<b>53</b>
5.1	Overview .....	53
5.2	Evaluation Process.....	54
5.2.1	Evaluation Purpose .....	54
5.2.2	Evaluation Questionnaire.....	55
5.3	Evaluation Process Design .....	55
5.3.1	Preliminary Evaluations.....	55
5.3.2	User Evaluations .....	56
5.4	Findings of the Evaluation.....	56
5.4.1	Evaluator Purpose .....	56
5.4.2	Evaluator’s Feedback.....	63
5.5	Guidelines for VECW Framework .....	66
5.6	Summary.....	69
<b>6</b>	<b>Conclusions .....</b>	<b>71</b>
6.1	Introduction .....	71
6.2	Realisation of Aims and Objectives .....	71
6.3	Contribution to Existing Theory and Practice .....	72
6.4	Implications / Impact on Sponsor.....	73
6.4.1	Identifying ServQ Issues.....	73



---

6.4.2	Improving Communications and Relationships.....	73
6.4.3	Improving Processes .....	74
6.4.4	Critique of existing tools.....	74
6.4.5	How to Use the VECW Framework .....	74
6.5	Implications / Impact on Wider Industry.....	74
6.6	Critical Evaluation of Research.....	75
6.7	Recommendations for Further Research .....	76
6.8	Conclusions .....	78
<b>7</b>	<b>References.....</b>	<b>79</b>
<b>Appendix A</b>	<b>– Paper 1 (Journal) .....</b>	<b>87</b>
<b>Appendix B</b>	<b>– Paper 2 .....</b>	<b>105</b>
<b>Appendix C</b>	<b>– Paper 3 .....</b>	<b>121</b>
<b>Appendix D</b>	<b>– Executive Summary of ServQ Tools and Techniques .....</b>	<b>145</b>
<b>Appendix E</b>	<b>– Preliminary Case Study Questionnaire .....</b>	<b>165</b>
<b>Appendix F</b>	<b>– Collaboration Charter for ServQ.....</b>	<b>167</b>
<b>Appendix G</b>	<b>– IDEF0 Diagram.....</b>	<b>173</b>
<b>Appendix H</b>	<b>– Tools Scenario for ServQ Project.....</b>	<b>183</b>
<b>Appendix I</b>	<b>– Evaluation Questionnaire.....</b>	<b>189</b>



---

## TABLE OF FIGURES

**CHAPTER 1**

Figure 1.1 – Dissertation Schematics.....5

**CHAPTER 2**

Figure 2.1 – Different types of collaboration (from Attaran *et al.*, 2002).....8

Figure 2.2 – Possible value conflicts in collaborative working (from Kerzner *et al.*, 2009)...14

**CHAPTER 3**

Figure 3.1 – Comparison of deductive and inductive research approaches (adopted from Gill, 2002).....24

Figure 3.2 – Classification of participant observation roles (adopted from Brymann *et al.*, 2003).....26

**CHAPTER 4**

Figure 4.1 (a) – The research development process (Objective 1 and 2).....34

Figure 4.1 (b) – The research development process (Objective 3, 4 and 5).....35

Figure 4.2 – Conceptual VECW framework.....38

Figure 4.3: Node A2 of ServQ’s process model.....46

**CHAPTER 5**

Figure 5.1 – Evaluation process.....53

Figure 5.2 – People factor mechanism evaluation process (Preliminary).....59

Figure 5.3 – People factor mechanism evaluation process (User).....60

Figure 5.4 – Process factor mechanism evaluation process (Preliminary).....61

Figure 5.5 – People factor mechanism evaluation process (User).....61

Figure 5.6 – Tools factor mechanism evaluation process (Preliminary).....62

Figure 5.7 – Tools factor mechanism evaluation process (User).....62

Figure 5.8 – Overall impact on collaboration evaluation responses (Preliminary).....63

Figure 5.9 – Overall impact on collaboration evaluation responses (User).....63

Figure 5.10 – VECW Framework Guidelines for ServQ.....68

Figure 5.11 – VECW Framework General Template.....69

**CHAPTER 6**

Figure 6.1 – The Swiss cheese model of collaboration Issues (adopted from Reason, 1990).....77

Figure 6.2 – Collaboration issues passing through each level (adopted from Reason, 1990).....77



---

## TABLE OF TABLES

**CHAPTER 2**

Table 2.1 – The evolution of strategic focus in collaboration (Thompson, 2008).....	9
Table 2.2 – Changing value attributes for sustaining collaboration (Adopted from Hultman <i>et al.</i> , 2002).....	15
Table 2.3 – Desk study of proprietary collaboration tools available with ServQ.....	19

**CHAPTER 3**

Table 3.1 – Research approaches explanation.....	22
Table 3.2 – Research methods used.....	27
Table 3.3 – Identification of themes for evaluation.....	30

**CHAPTER 4**

Table 4.1 – Comparison of old partnership agreement & proposed collaboration charter.....	41
Table 4.2 – Internal factors and external forces of scenario building for construction industry clients (based on Hirschhom, 1980).....	50

**CHAPTER 5**

Table 5.1 – Types of Evaluation (based on Preskill <i>et al.</i> , 1999).....	54
Table 5.2 – Evaluation of Mean, Median and Standard Deviation for responses of Generic as well as User Evaluation.....	57
Table 5.3 – Benefits of the VECW framework.....	64
Table 5.4 – Barriers to VECW framework.....	65
Table 5.5 – Suggested enhancements to VECW framework.....	66

## LIST OF PAPERS

The following papers, included in the appendices, have been produced in partial fulfilment of the award requirements of the Engineering Doctorate during the course of the research.

### JOURNAL PAPERS

1. Gohil, U., Carrillo, P.M., Ruikar, K.D., Anumba, C.J., 2011, "Value-enhanced collaborative working: case study of a small management advisory firm", *Construction Innovation: Information, Process, Management*, Vol. 11, Issue 1, pp 43 – 60.
2. Gohil, U., Carrillo, P.M., Ruikar, K.D., Anumba, C.J., 2009, "Fostering Collaboration within an SME Services Organisation", *International Journal of Knowledge, Culture and Change in Organisations*, Volume 9, Issue 4, pp 107-122.
3. Gohil, U., Carrillo, P.M., Ruikar, K.D., Anumba, C.J., 2010, "Development of a Business Process Model for a Project-Based Organisation", *International Journal of Knowledge Based Organisations* (Accepted).

# 1 INTRODUCTION

## 1.1 INTRODUCTION

The objective of this chapter is to provide an introduction to the subject of Collaborative Working (CW) within the SMEs in service industry. For the current research SME is defined as any organisation with a total workforce of less than 250 people and a turnover total of less than 50 million Euros a year (EU, 2005). It further explores the context of the research within the service industry as well as ServQ (the industrial sponsors) for the current project. In addition, it presents a justification for the study and outlines the aims and objectives of the doctorate research.

## 1.2 THE RESEARCH DOMAIN

In the last decade there has been an exponential growth in the service industry transforming the way businesses work. The increased technological innovations have had a high impact on the wide range of services transforming many service industries and firms (Segal-Horn, 2006). This exponential growth within the service industry is the direct result of the current organisational trends of concentrating on core activities by outsourcing and downsizing.

The service sector in general has distinctive qualities as compared to the more traditional manufacturing sector. An important distinction is that the output of service industries or service firms is not a product but an intangible commodity (IMF, 1993; Zeithaml and Bitner, 1996). Such differences are documented since the service industry first started playing an enhanced role as an industry in 1990s (Riddle, 1986; Zeithaml and Bitner, 1996). Segal-Horn (2006) defines the most important characteristics that define the differences between products and services as: intangibility, heterogeneity, simultaneous production and consumption, and perishability.

In recent years, the complex and turbulent business environment has led to organisations taking an approach of sharing risks and getting access to improved resources with the help of inter-firm collaborations (Gomes-Casseres, 1996; Kogut, 1998). The benefits of entering into such collaborations have been documented in several notable publications (Das *et al.*, 2000; Anand and Khanna, 2000; Hoffmann *et al.*, 2001; Belderbos *et al.*, 2004). However, the value of such collaborations in the Small and Medium sized Enterprises (SMEs) involved in service industries is not well documented. In addition, the current economic climate makes it harder for SMEs to survive without value enhancements to its organisation through collaborative arrangements. Hence, this research is based on the assertion that there is a need to investigate the enhancement of value in an organisation by collaborative arrangements in SME service firms.

The next section will give the research context in terms of collaborative working in SME firms.

## 1.3 THE RESEARCH CONTEXT

Since SMEs are characterised by scant resources, they are expected to enter into collaborative relationships. The value of such collaboration is in the pooling of resources to help exploit complementarities between the collaborating parties. In essence, it is a way to provide access to external resources within short period of time resulting in economies of scale and scope

(Katrishen *et al.*, 1998). Hence, a large part of SME firms rely on collaborations and partnering with other businesses. The nature of industries like aerospace components' manufacturing meant that SMEs had to collaborate to survive. However, traditional industries such as Construction, which has traditionally struggled with the concept of collaboration and partnering also identified it as a major enabler to solving many of its inherent problems such as fragmented nature, lack of integrated processes and transparency and slow in adoption of new technologies (Latham, 1994; Egan, 1998; Egan, 2002, Wolsteholme, 2009).

The perceived value of the collaboration between any two entities is based on the usefulness of the product or service generated through the arrangement (Zeitaml, 1988). This value is perceived differently by the various collaborating entities within the arrangement. There are many studies relating to the determinants of a collaboration success or failure (eg., Park *et al.*, 1997; Kogut, 1998) but few studies help to provide a framework to cover the factors responsible for an enhanced value within collaborative working. In particular, the propensity to successfully collaborate in SME is significantly less than that of large organisations (Hoffmann *et al.*, 2001). A real problem of collaboration in such SME services industry is to ensure that all stakeholders understand the roles and responsibilities of getting involved in such an arrangement. In addition, at all times, it has to be ensured that the people collaborating are in a win-win arrangement. Thus, the collaboration requires a bottoms-up approach promoted through a continuous improvement process with the help of a framework. This research builds on an investigation within a SME services organisation involved in CW (Collaborative Working) to find ways of improving performance within the organisation. The organisation recognised a need to build a holistic and comprehensive framework covering all aspects of CW. The expected end result should be a guidance to recognise and prioritise actions to enhance value within a collaborative arrangement. For any services organisation, such an initiative would help in providing a systematic way of entering and then sustaining collaboration.

### **1.4 THE INDUSTRIAL SPONSOR**

This research project was initiated by an industrial sponsor, ServQ Limited, in collaboration with Centre for Innovative and Collaborative Engineering (CICE) at Loughborough University. ServQ Limited was founded in 2002 as a small management advisory firm based in UK. The relatively new organisation was founded by highly experienced practitioners from the fields of service businesses, consultancies, infrastructure, utilities, manufacturing and public sector organisations. The core business of the firm is to provide consulting advice in the fields of Strategy, Partnering and Organisational Alignment for various industries ranging from construction to aerospace manufacturing and from medium-sized manufacturing firms to academic institutions. On an average, ServQ normally had one big client and couple of small clients to cater on an ongoing basis. The value of the big project ranged between five hundred thousand and one million pounds while the smaller projects were less than hundred thousand pounds.

ServQ wanted to provide a portfolio of services while keeping the operating costs down by reducing overheads wherever possible. Hence, the organisation adopted a collaboration model where Associates, Strategic Partners and Directors share resources, expertise and knowledge to achieve business objectives. ServQ works collaboratively with Associates on different projects, while Strategic Partners develop proprietary management tools and licence it to ServQ.



ServQ sets itself apart from other advisory firms through its heavy reliance on external collaboration to support strategic as well as organisational activities. It has expressed a desire to develop mechanisms for building trust and support team building by making consensus with other people as an essential part of their process. Hence, the organisation has recognised the intangible resource strength of the firm is derived from the collaborative arrangement with other firms. Since these external collaborators are geographically dispersed, ServQ considers it important to consider itself as a virtual organisation.

At the start of the project, ServQ Limited wanted to develop a framework for implementing major performance improvement within the firm by creating a common platform, combining all the collaborative tools in their portfolio of products. The initial observations of the working arrangement within the firm assisted in recognising a need to take a holistic view and try to enhance the value generated by collaborative working arrangements. Hence, it should be noted that the original concern formulated by the industry sponsor required a rethink and the revised research aim was more reflective of the holistic issue faced by collaboration within ServQ and its collaborators.

## **1.5 AIM OF RESEARCH**

The main aim of this research project is ‘To investigate the potential of Value-Enhanced Collaborative Working in an SME management advisory firm’. In order to satisfy this aim, the research project had five objectives and their respective deliverables. The deliverables were in the form of reports and publications. The five identified objectives are stated in the next section.

## **1.6 RESEARCH OBJECTIVE**

The following are the research objectives for the project:

*Objective 1: To understand the foundations of Collaborative Working and Value with respect to SME service industry.*

This was the exploratory phase of the research that dealt with researching the concept of CW and Value in general, as well as in the context of SMEs and Services firms. The deliverable of this objective was an academic paper (Paper 1, Appendix A).

*Objective 2: To investigate patterns of Collaborative Working within ServQ, and to identify areas of process improvements.*

This objective helped identify the areas that required the attention within this research to acquire the required process improvement outcomes. A product of this objective was the conceptual framework of Value Enhanced Collaborative Working (VECW) based on the constraint areas based around the themes of collaborative working processes, information transparency and communication. The deliverable of this objective was a set of factors that were responsible for process improvements and collaboration within the sponsor organisation.

*Objective 3: To further explore the identified concern areas for process improvements.*

This objective individually examined the CW within the identified constraint areas in further detail resulting in three different but interdependent set of factors that enhance the value of CW. The deliverables of this objective were two academic papers as well as an internal organisational document that discussed in detail each of the identified factors with respect to the sponsoring organisation in Chapter 4.

Objective 4: *To develop and evaluate a comprehensive framework to enhance Collaborative Working.*

This objective was to prepare a comprehensive framework by understanding how the different factors are inter-related or dependent on each other and together enhance the CW. It was followed by evaluation phase of the framework. The deliverable of this factor was a comprehensive VECW framework as described in chapter 5 section 5.5.

Objective 5: *To identify the managerial implications of the research.*

The last objective was to summarise the work in the wider industrial context with respect to the objectives and provide the managerial implications of the research. The deliverables of the last objectives were the implications and roadmap of the VECW framework with respect to ServQ and the potential impact on the wider industry as described in Section 5.5, 6.4 and 6.5.

## **1.7 JUSTIFICATION OF THE RESEARCH**

In the current dynamic business environment, uncertainty is a fact of life in all industries making them strategically susceptible of being caught out due to lack of resources or high risk ventures not working out. Collaboration provides a flexibility that helps reduce this susceptibility against the varying market conditions. Porter and Fuller (1986) identified the most common motivations for collaboration as:

- 1) Achieving economies of scale and scope;
- 2) Access to more resources (in the form of technology, market access, manpower, etc.);
- 3) Reduce risks; and
- 4) Improved process rationalisations and system improvements.

However, the creation as well as sustenance of a collaborative environment needs to consider many factors. The success of any collaboration depends on the choice of partners, the management of alliances as well as the evolution of the collaboration (Faulkner, 2006). Specially, with reference to SME service organisations, there is a need to investigate, in detail, how all these CW features will result in a collaboration success or failure.

Within academia, this research should provide needed literature on the specifics of collaboration within service industry, especially in the SMEs. In addition, it would help in developing a practical approach of collaboration development and sustenance through the generation of a framework. The real problem is to get the SMEs to act together in a consistent manner to sustain long term collaboration since the advantages of collaboration are easy to ascertain over a period of time. This framework should provide a continuous improvement process to ensure that the collaboration is always dynamic and reflective of the requirements of its stakeholders. This should in turn lead to an internal flexibility in the collaborative arrangement of the SME service organisation to face unexpected market changes that are so common in the current climate.

## **1.8 SUMMARY**

The overall aim of the research is *‘To investigate the potential of Value-Enhanced Collaborative Working in an SME management advisory firm’*. The result of this work should be a framework to help ServQ Limited, and similar organisations, generate more value out of its collaborative arrangements with other firms.

Sections 1.2 and 1.6 pointed out the need for academic work on CW within the service sector. The objectives of this research addressed the needs of the industrial sponsors. Since the industrial sponsors depended heavily on collaboration, the expectations of all collaborating stakeholders within the research project were identified.

The structure of this thesis can be explained with the help of the following ‘dissertation schematics’ (see Figure 1.1). It outlines the structure of the thesis and the corresponding papers written to fulfil the research objectives.

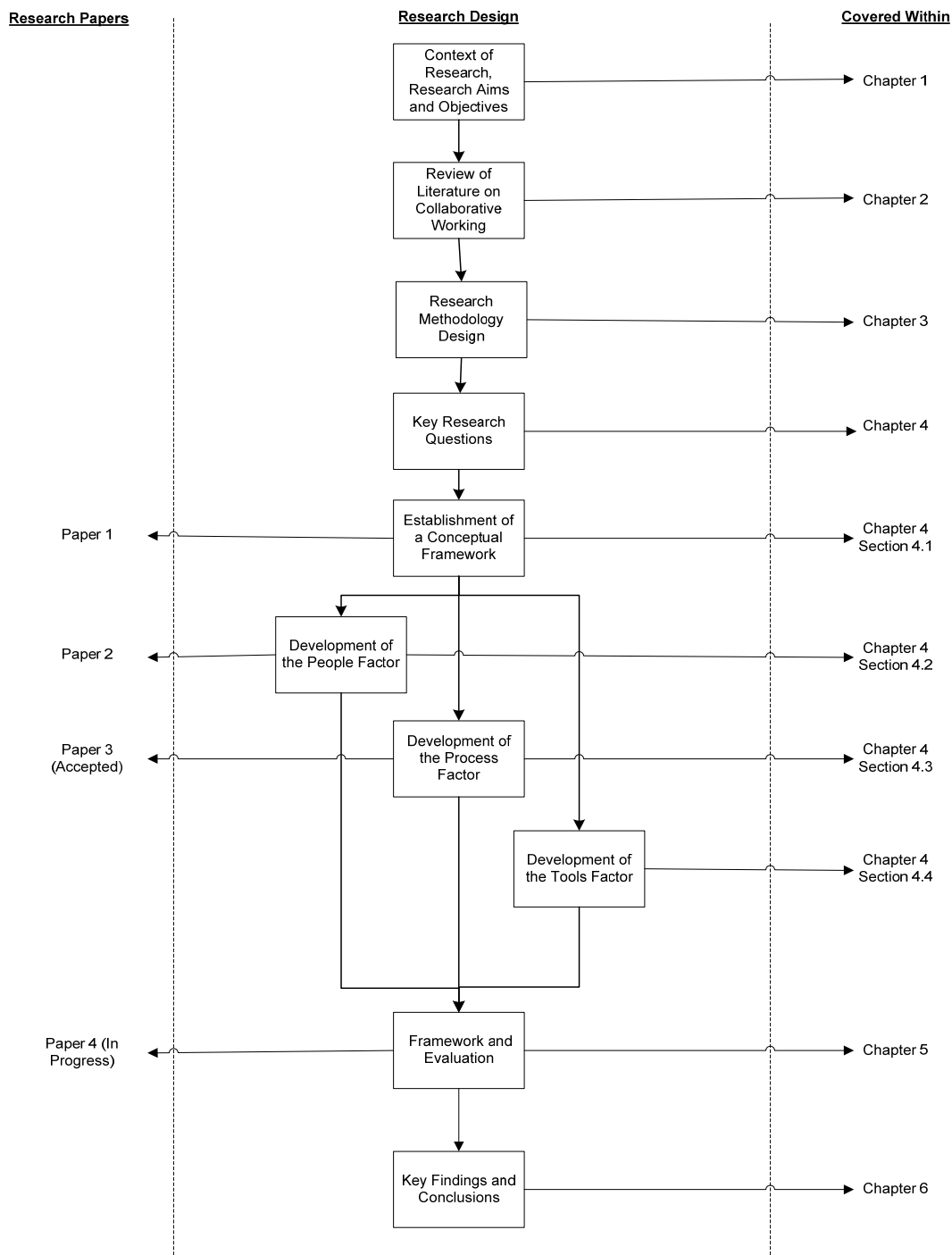

**Figure 1.1 - Dissertation Schematics**



## 2 LITERATURE REVIEW

### 2.1 INTRODUCTION

This chapter consists of a synthesis of the literature available in the fields of collaboration and collaborative working. This initial task was considered essential for the research to identify the already published research work in the area. Collaboration is an all-encompassing activity and hence, the resulting literature on this subject can be found in a wide range of disciplines such as organisation, decision sciences, management, IT and engineering.

The purpose of this review was to gain an overview of related research and the level of understanding concerning the different facets of collaboration. Further to this, it was important to understand collaboration in relation to small service firms to establish specific issues of collaboration within such organisations. Following the initial review of generic collaboration and concurrent engineering literature, further reviews were undertaken to investigate the value attributes important to the collaborative working and the different factors responsible for collaboration, as the research progressed.

The review helped to establish that although collaboration increasingly plays an important role in most organisational environments today, there are numerous difficulties to carry out collaboration that yields consistent and intended outcomes in terms of performance improvements within inter or intra-organisational collaboration. The issues range from the definition of collaboration within an organisation to adopting a successful collaborative working programme. The focus of most of the collaboration literature remains large organisations and hence, in comparison, there is a lack of research on collaboration in SMEs, especially small service firms. Although the focus of recent collaboration literature has gradually shifted towards SME organisations, it still remains an area in need of further research. The review underpinned the first two research objectives, in particular by identifying a number of factors responsible for contributing to the effectiveness of collaborative working.

### 2.2 COLLABORATION

Collaboration as a term has been defined by many different researchers over a period of time. Barthelmeß (2003) defined collaboration as an awareness of each other's actions through user communication and user awareness thus outlining the importance of constant communication of the actions. Attaran and Attaran (2002) however took an organisational point of view to define collaboration and described it as two or more companies working together by sharing common information and successfully executing project by planning based on the shared information. Kvan (2000) ascertained the significance of collaboration as a personal lifestyle and a philosophy that is based on shared goals to find satisfying solutions for all concerned. Hence, depending on the point of view of the researcher, many different facets of collaboration are evident from the different definitions.

Shelbourn *et al.* (2005) provided a definition based on an extensive literature review of collaboration as an activity where a large task is achieved by a group of people by assembling their collective resources. Their research specifically identifies the contribution of frequent communication and knowledge sharing for collaborative purposes and identifies the need for effectiveness in the following areas for a collaboration to be successful:

- developing shared meaning;
- developing shared memories;
- negotiation;
- communication of data, knowledge, information;
- planning of activities, tasks, methodologies; and
- management of tasks.

Originally Attaran and Attaran (2002) proposed four modes of collaborative computing technology based on time and space dimensions. Based on their nature of spatial separation and pattern of communication, Attaran and Attaran (2002) identified four modes of collaboration, as shown in Fig. 2.1.

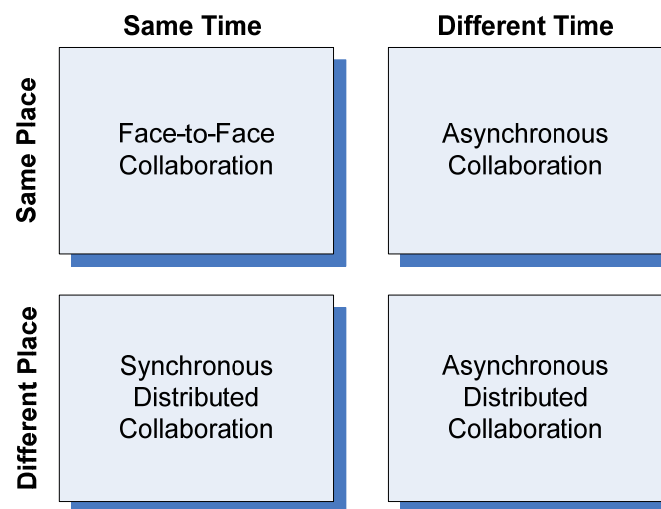

**Figure 2.1 - Different types of Collaboration (From Attaran and Attaran, 2002)**

- Face-to-Face Collaboration – This would occur when participants are engaged in face-to-face discussions in a venue such as a meeting room.
- Asynchronous Collaboration – This mode of communication occurs when a medium like a notice-board or bulletin boards are used.
- Synchronous Distributed Collaboration – Any technology that helps in real time communication of two or more parties that are not in the same place falls under this. It can occur with the help of telephones, video conferencing or editing facilities.
- Asynchronous Distributed Collaboration – This is a result of distributed communication in a non-real time for e.g. newsletters, fax machines, telephone messages, pages, electronic mails, etc. (Anumba *et al.*, 2002)

Some researchers further stated the possibility of one-to-one, many-to-many, many-to-one (May and Carter, 2001) and many-to-many (Wilkinson, 2005) dimensions of the collaboration. Researchers like Daugherty *et al.* (2006) are still not convinced about the lessons learned from the industry and research regarding the advantages of collaboration and how best to manage it. They feel that significant importance in research is provided on how to set up collaboration. However, less importance has been given to the strategic aspects.

Hence, the section below gives an overview on the use of collaboration for strategic advantage.

### 2.2.1 COLLABORATION FOR STRATEGIC ADVANTAGE

Different types of collaborative arrangements such as strategic alliances, joint ventures, dynamic networks, cooperative agreements and strategic networks have been adopted and proved a significant strategic choice in different types of organisations in a wide variety of industries (e.g. construction, manufacturing, services, etc.). Specifically in the Small and Medium sized Enterprises (SMEs) sector, the traditional business has made way to what Handy (1992) describes as ‘The Federated Enterprise’; this is done by establishing strategic networks and through the development of so-called virtual networks. Such a collaboration strategy is founded on the examination of a firm’s existing resources and core competencies and fills whatever resources or competency gap is revealed in relation to the perceived potential profit opportunities (Grant, 1991).

Another good example of a motivation for collaboration in construction industry is the use of ‘prime contracting’ for a project to ensure pain/gain-sharing mechanisms (OGC, 2003). The Andover North redevelopment project was one of the earliest prime contracting projects that included a partnering charter, joint project bank accounts and collaborative IT. This uses extensive collaborative charters to ensure that the project promotes aspects of collaborative working, including:

- Focusing the whole team on delivery;
- Equal sharing of risk;
- Managing risk rather than transferring it;
- Continually assessing cost, time and quality.

Increasingly, authors like Thompson (2008), Zuboff *et al.* (2005) and Gustafsson *et al.* (2003) have realised the strategic advantage of a value driven collaboration. Thompson (2008) further characterises the current strategic focus of organisations to become ‘value driven enterprise networks’. He argues how different decades have led to different strategic foci in terms of value as explained by the Table 2.1. In the ‘experience value’ the focus is on intellectual property including human and relational capital, as well as, holistic (end to end) processes to solve client issues with the help of relevant technology.

**Table 2.1 - The evolution of strategic focus in collaboration (Thompson, 2008)**

<b>Era</b>	<b>Decade</b>	<b>Relation to the Market</b>	<b>Strategic Focus</b>
<b>A</b>	1970s	Transactions	Product Value
<b>B</b>	1980s	‘Moments of Truth’ – Customer Contact Points	Service Value
<b>C</b>	1990s	Relationships: Lifetime Value of Customers	Solution Value
<b>D</b>	2000s	Alliances and Networks	Experience Value

### 2.3 COLLABORATION WORKING WITHIN SMES

Collaboration within SMEs has grown in significance since the last couple of decades. A government article (DTI, 2005) concluded that government buyers should seriously consider bids by SMEs. However, the SMEs do not have the resources, qualifications or experiences to develop, submit and win major public sector bids and hence, collaborations are the only

viable option by which SME can win government bids. SME personnel are often overloaded with multiple-tasks, which impact on organisational performance and efficiency (Major and Cordey-Hayes, 2000). In addition, their governance and reward structures are different (Hausman, 2005). Also, personnel usually have fewer external contacts to increase their adaptation capabilities in response to changes in the economic, technological and competitive markets (Drozdow and Carroll, 1997). Hence, no small firm would have all the necessary resources to stay viable in the current competitive market and as a result, a large part of their business relies on collaboration and partnering with other businesses. Such arrangements are useful for the SMEs to pool resources, exploit complementarities and provide quick and flexible access to external resources (Das and Teng, 2000; Anand and Khanna, 2000; Hoffmann and Schaper-Rinkel, 2001; Belderbos *et al.*, 2004). Consequently, collaborative working has the potential to enable SMEs and people working within these organisations to work more effectively with stakeholders and perform combined actions across various cultural, disciplinary, geographic and temporal boundaries (Hammond *et al.*, 2001; Attaran and Attaran, 2002).

An important issue in collaboration arises due to different working practices among the collaborating organisations. The nature of organisational issues, such as conflict resolution and adoption of common processes, etc., within stakeholders and clients are barely structured and not always recognised in service organisations (Creplet *et al.*, 2001; Kakabadse *et al.*, 2006). Such situations demands specialised knowledge and capabilities. The result of this requirement is dependency on superior access to human resources through collaborative arrangements. To derive maximum value from such arrangements, researchers identified a number of features that can be added to the collaborative arrangement such as:

- Collaborative decision making (Mudambi and Helper, 1998; Cardell, 2002);
- Recognition of the need to actively manage multiple actors' interests (Boddy *et al.*, 1998); and
- Equitable benefit sharing (Cox, 2001).

The following two sub-sections discuss the benefits as well as issues of collaborative working based on various industries.

### **2.3.1 BENEFITS OF COLLABORATIVE WORKING**

Studies have provided evidence that the benefits of collaboration are observed in a wide variety of industries (Ellis *et al.*, 1993; Mills, 1998). The Network for Construction Collaboration Technology (NCCTP) promotes the effective use of online CW technology (NCCTP, 2003). According to NCCTP (2003) the benefits of CW can be both tangible (e.g. reductions in travelling and meeting costs, telephone costs, storage of drawings cost, etc.) as well as intangible (e.g. time, quality). Similarly, Thompson (2008) identified the following major benefits of collaboration especially in a virtual organisation setting:

- Improved responsiveness;
- Simplified and consistent interfaces;
- Reduced overheads;
- Better communications and tracking;
- Wider range of core competencies (services);
- New and innovative ideas, services and products; and
- Access to non-commercial partners (universities).



Daugherty *et al.* (2006) argued that formalisation of strategic collaboration sets expectations of what should be done to help establish standard practice. The benefit of such an arrangement can be elimination of ambiguity and clarification of priorities to provide focus and save time. However, the authors recognise the potential reductions of collaborative flexibility and agility. Accordingly, the researchers encourage formalisation only within reason leading to greater emphasis on operations-level communication formalisation as compared to strategic-level flexibility. Grieves (2000) in his seminal work on Organisational Development (OD) discussed the need to derive benefits from collaborative working. This research suggested that collaborative working helps to keep focus on customers, helps constant innovation and employees as well as collaborators are regarded as a resource rather than a cost. Hence, the various characteristics of collaboration according to Grieves (2000) are as follows:

- Symbiosis/synergy suggesting the different organisations collaborating to provide a united front for mutual benefit. Symbiosis is a reciprocal exchange between collaborators to provide various stakeholders with added value;
- Development of knowledge intensive firms through networks. They depend on the pursuit and sharing of knowledge in order to constantly innovate through multi-disciplinary expertise and collaborative learning;
- The strategic management of a group of independent collaborators who gradually and collectively become interdependent; and
- An organisation culture that is shaped by knowledge sharing and trust between the various stakeholders.

Lastly, Lu *et al.* (2007) divided the typical benefits of a collaborative undertaking into two categories: teamwork (i.e. process) paybacks and task-work (i.e. result) paybacks. Benefits in teamwork could consist of better communication, possibility of remote teamwork (virtual organisation), shared understanding, collective and faster decision making and clear ownership of processes. Whilst, task work related benefits could consist of improved innovation, better technology integration, enhanced total value as well as lower resource costs. However, the benefits of collaborative working must be balanced against the possible issue in collaborative working that could result in failure of the collaboration effort. The varied issues that can fall under this category are discussed in the next section.

### **2.3.2 ISSUES IN COLLABORATIVE WORKING**

There are some distinct challenges to collaborative working in the industry. These challenges are studied by researchers such as Shelbourn *et al.* (2005) in construction industry, Lu *et al.* (2007) for engineering industries, Grieves (2000) from an organisational development point of view and Thompson (2008) from a SME point of view.

According to Shelbourn *et al.* (2005), in construction firms people and relationships are at the heart of collaboration, but it is not always possible to have a continuity of relationships. At organisation, team and individual levels, a lack continuity in relationships results in lack of development of trust and commitment between the collaborators. Hence, long term relationships are not sustained mainly due to people related issues. Shelbourn *et al.* (2005) also raised concern regarding technology issue of collaboration when there are a wide variety of tools used among stakeholders or there is limited awareness and lack of management support for collaboration tools.

Lu *et al.* (2007) identified three distinct issues that prevent effective collaborative working within industry. The first issue is the effect of trying to solve a problem without the clear definition of the problem resulting from a process that is not designed for collaborative working. A properly defined and shared problem enables collaborators to come up with varied solutions for effective decision making. The second challenge is that the collaborators can have diverse interests, expertise and access to information about the problems resulting in them perceiving problems differently due to the people related issues. Such varied perspectives can lead to incompatible opinions among the collaborators. In addition, sometimes, the collaboration is led by one powerful organisation, leading to disparity of power and resources to solve the problems. Nicholas (1994) brought to light issues such as the failure to resolve differences in orientation among collaborators, weak or inappropriate goals for collaborators, and, paradoxically, too much team spirit that could result in a team that builds a wall between itself and important outsiders.

Thompson (2008) explained how a wide variety of ad-hoc collaborations involving SMEs fail in sustaining collaboration. According to Thompson (2008) the following are the main reasons for the failure:

- Unrealistic expectations of collaboration without major investment on the part of the SMEs. A lack of trust between collaborators can lead to opportunistic behaviour and under investment that kills the collaboration.
- Commitment in terms of giving resources for the effort involved in preparing a major bid. There is a lack of immediate return on such personal investment of resources but it is required before the collaborative SMEs start winning big bids.
- Collaborative SME networks or organisations would lack scale and credibility without some large organisations. However, a large organisation might effectively takeover the collaboration.
- Some of the collaborations are formed as a response to market opportunities or to tackle specific projects. The fluid organisational boundaries in such projects can be a source of complex legal issues, for e.g., discussion on the intellectual property rights of the final service or product (Grimshaw and Kwok, 1998)

Grieves (2000) emphasised the failure of collaborative working in terms of human factors associated with organisational development. The situation is reflected through the following mentioned causes:

- The failure of top level management to estimate the complexity related to the change in terms of collaborating stakeholders with diverse working practices and organisational culture;
- A drain on resources due to impaired performance (of one or more collaborating stakeholders); and
- Underestimation of the human issues (related to value and values of individuals) (Marks, 1997).

There has been increased dependence on technology to support collaboration since the last few years. However, Wilkinson's (2005) work clearly observed the different issues arising due to the resistance to collaboration technologies and due to the inability to manage the human/technology issues. According to Wilkinson (2005) the single biggest impediment to successful collaborative working has been the failure to understand and adapt human behaviour and not the technology itself. The work also reflects on the barriers to collaborative

technology investment since the organisations perceive it to be expensive with a high rate of changes and associated costs. The demographics of the organisation can also influence the take-up or buy-in of the technology since generally older generation is more reluctant to adopt IT.

Hence, there are a wide variety of issues in collaborative working with some parallels between the identified literature sources. For the current work, the author considers Wilkinson's (2005) definition of collaboration as a 'creative process undertaken by two or more interested individuals, sharing their collective skills, expertise, understanding and knowledge in an atmosphere of openness, honesty, trust and mutual respect, to jointly deliver the best solution meeting their common goals' as appropriate. It is clear to see that to sustain collaboration, people issues would need to be addressed in detail. However, these issues are directly related to the value attributes that the individuals and organisations put to rectify these issues and hence, the next section will discuss the role of Value in collaborations.

## **2.4 VALUE WITHIN COLLABORATIVE WORKING**

Value is very subjective, as it is a matter of opinion, compared to cost which is a measure of the amount of money, time and resources to obtain a requirement. Any attempt to provide a definitive description of value must be valid in many different contexts (Woodhead and Downs, 2001). Although the concept of value can have many definitions, generally they are not divergent (Anderson *et al.*, 1993, Monroe, 1990; Gale, 1994; Woodhead and Downs, 2001). These definitions mainly address 'hard' attributes of values whereas the 'soft' attributes such as those of Emmitt and Chirstofferson (2008) also need to be discussed. The importance of values is that once it is internalised it becomes, consciously or subconsciously, a criteria for guiding one's beliefs (Bruno and Lay, 2008). Values exist in relation to the values held by others and are thus not absolute and are in constant transformation. Hence, agreement of an objective best 'value' for a group can differ from the individuals' perception of value.

Generally, different types of value drivers are indicators for measuring different aspects of sustainable collaboration. In collaborative working, stakeholder value drivers are important since they are affected by or can be influenced by the collaborative arrangement of the organisation. Kerzner and Saladis (2009) emphasises that each stakeholder can have a different perception of value and this perception is not always a business-based (i.e. economic) perception of value. Value enhancement within collaborative working can occur, only when each stakeholder decides – what they perceive as value gained personally or what the collaboration will gain in terms of value. This can be best explained by the value conflicts that stakeholders might face within the collaboration as explained by Figure 2.2.

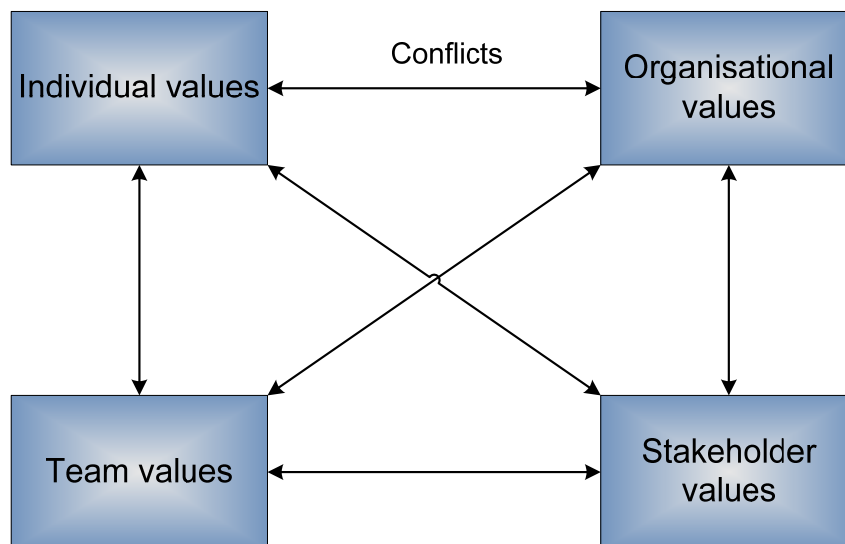

**Figure 2.2 - Possible value conflicts in collaborative working (from Kerzner and Saladis, 2009)**

The collaboration would require acknowledging all these values and balance, if possible, each perception of value. Some of the values are highly individual to the person involved in the project imbibed through his or her personal experiences, while, other values are a result of the team dynamics based on their combined previous experiences. The different types of stakeholders have their unique take on values based on their designation within the team (for e.g. clients expect things in a particular way as compared to the sub-contractors). Lastly, each individual works in a particular organisation that has its own set of values and all these values are not always similar. Sometimes they seem to be in conflict with each other.

Emmitt and Chirstofferson's (2008) soft values should ideally be achieved in the short term for the daily operation of the collaboration, since it affects the way people work together. These can be enhanced by work on issues pertaining to teamwork, communications, trust and commitment (Kerzner and Saladis, 2009). In comparison, an organisation's 'use' values are those values that must be achieved for long-term sustainability of the collaboration (McPherson, 1998). These are hard values like percentage of market share, brand recognition and development of intellectual property.

Whilst, soft values seem to be intangible as compared to the hard value attributes of the 'use' value. In a social construct like collaboration, the success of achieving strategic value over a sustained period of time depends on the success of the soft values in day to day life (McPherson, 1998). Hence, both hard and soft values are complementary to each other, especially in collaborative working.

Hultman and Gellerman (2002) listed the value attributes that the collaboration should move towards to ensure the sustainability of collaboration through value enhancement. This move from ineffective values towards effective value is an inclusive process, since all collaborators need to share similar values to truly achieve collaboration. Table 2.2 below provides the list of ineffective values that should be converted to effective values to sustain collaboration for a long-period of time.

**Table 2.2 - Changing value attributes for sustaining collaboration (Adopted from Hultman and Gellerman, 2002)**

<b>Moving away from: (Ineffective values)</b>	<b>Moving towards: (effective values)</b>
Mistrust	Trust
Internal focus	Stakeholder focus
Conformity	Innovation
Predictability	Flexibility
Reactive management	Proactive management
Formality	Informality
Bureaucracy	Fluid boundaries
Tactical thinking (short-term)	Strategic thinking (long-term)
Compliance	Commitment

The attributes in Table 2.2 mainly appear in the foundation values, since they are short-term and form the basis for the long-term strategic values. McPherson (1998) identified the surprising realisation that such foundation values are essentially only creating potential as embodied in the quality of its outputs and impacts. Hence, a business cannot by itself determine how valuable it is, the actual value added is through the strategic value over a period of time, identified through the information of responses of stakeholders as well as clients. Such information mainly consists of revenues, status and reputation as accessed by these stakeholders and clients.

The phenomenon above indicated that, a collaborative working arrangement can be considered to be sustainable when the collaboration can come up with mechanisms that help to move from ineffective values towards the effective values as described above. Carrying out the transformation of value attributes would be dependent upon the identification of important factors for collaborative working in SMEs, since these factors can help to measure these ineffective values been converted into effective values.

The understanding of value and how it affects collaborative working should also consider the aspects of lean thinking. The popularity of lean thinking can be traced back to Womack *et al.* (1990) that described the results of the International Motor Vehicle Programme (IMVP) research project at MIT. Although lean thinking in literature is facing an issue of lack of common definitions (Jorgenson and Emmitt, 2008), in essence it stresses on the importance of individuals becoming fully engaged and taking ownership of organisational processes for its successful implementation. Koskela (1992) was among the first researchers to use lean thinking in construction industry. The subsequent lean construction literature primarily deals with tactical subjects with some research at strategic and operational level. Alarcon (2007) identified heavy reliance on tools, techniques and implementation strategies in the preliminary years of lean undertakings in organisations. Whilst small number of articles dealt with culture (Brochner 1995; Melles, 1994) and people (Melles 1994; Fisher 1995). The core elements of lean thinking that are common with value and collaborative working literatures are the process focus, continuous improvement, cooperative relationships and system perspective.

David Maister (1993) wrote extensively on managing professional services firm including what is value for such firms. The work is upfront in stating the need for organisations to

collaborate however warns of the tensions between the individual collaborators and the needs of the firm. To describe the Value that such firms generate, Maister (1993) gives the metaphor of farmers and hunters when describing the professional services firm. The community mentality of farmers and similar professional firms make them heavily reliant on 'niche' markets while the hunters and similar professional firms are more entrepreneurial and like to follow their own instincts. Hence, here there is a direct correlation between value and risk. Since the farmers and the professional firms try for better leverage through 'niche' markets, they do not diversify their risks. However, hunter firms attempt to maximize the entrepreneurialism of the members, by creating the maximum possible degree of individual independence.

Paper 1 (Appendix A) provided a conceptual framework to promote Value Enhanced Collaborative Working (VECW). It involved a comprehensive review of literature that led to a better understanding of collaborative working in a small firm context. The exploratory observations of a case study helped identify the issues of collaborative working in ServQ. The research was helpful in understanding the reasons for the apparent failure of the case study firm to derive value from its collaborative working model. The research also developed a conceptual VECW framework to give a structured approach to agree common goals, share risks and rewards, provide faster and clearer communications and information transparency between collaborating stakeholders. The next section discusses the factors usually identified by different researchers as being most relevant to collaborative working.

## **2.5 FACTORS AFFECTING COLLABORATIVE WORKING IN SMES**

A wide range of factors can affect Collaborative Working. Researchers like Koutsikouri (2009) identified Critical Success Factors (CSFs) for construction design teams. The CSFs emerging from that research such as focus on communication and relationship management; people management; training and development; and interdisciplinary leadership were directly pertaining to the issues faced by distinctive nature of the construction industry teamwork. Similarly, a look at literature discussing CW with respect to the issues faced by SMEs was important for the research.

Issues of collaborative working discussed in section 2.2.2 can be mainly divided into People, Process and Tools related issues. Researchers such as Prasad (1996), Austin *et al.* (2001) and Khalfan (2001) suggested similar factors to control the character of an organisation in their studies. Prasad's work was based on manufacturing organisations, while Austin *et al.* referred to design chains and Khalfan (2001) adopted a construction organisations' perspective. In addition, researchers like Shelbourn *et al.* (2005) had also identified business, people and technology as key strategic areas for effective collaboration. These areas can again be translated to People, Process (business) and Tools (technology) related factors. According to the respondents of Shelbourn *et al.*'s (2005) survey, people are the most important aspect of collaboration followed by process and technology.

### **2.5.1 PEOPLE FACTOR**

Collaborative working is a highly social phenomenon and stakeholder collaboration is often insufficiently informed by social science concepts (relating to motivation, team building, organisational culture, etc.) that are central to the understanding of collaboration between organisations as well as individuals (Shelbourn *et al.*, 2005). Normally, the basis of

collaboration is a partnership agreement prepared in view of protecting oneself from opportunism (Yli-Renko *et al.*, 2001), although another more sustainable and positive use can be creating and maintaining a long-term relationship between the parties (Frankel *et al.*, 1996). Given human bounded rationality specifically in long-term agreements, the uncertainties arising in longer period of time lead to incomplete agreements (Hart and Moore, 1999; Maskin and Tirole, 1999). Hence, a partnership agreement should ideally cover soft aspects of management referring to the development and management of relationship capital (Cullen *et al.*, 2000).

The Latham (1994) and Egan (1998) reports identified partnering as an important component for improving performance in the industry. In the construction context, Bennett and Jayes (1998) followed this report with 'The Seven Pillars of Partnering' that are important for most partnering and collaborative undertakings. It identified the following aspects to consider before setting up a partnering agreement:

- Commitment;
- Self-assessment;
- Selection;
- Mutual objectives;
- Problem resolution;
- Continuous improvement; and
- Risk and reward structures.

A direct result of these reports is the development of more collaborative forms of contracts in the UK AEC industry that has incorporated collaborative arrangements between multi-parties, for e.g. The Andover North redevelopment project (OGC, 2003). Here it is important to note the difference between collaboration and partnering. A partnership is a contractual relationship involving parties with joint rights and responsibilities. On the other hand, collaboration involves cooperation not always bound by contractuality. Collaboration exists when parties pool their common interests to promote broader interests.

Burt (1997), Hosmer (1995) and Rousseau *et al.* (1998) considered trust and commitment as the major aspects of relationship capital that should help in facilitating long term sustainable relationships. Trust is defined as having sufficient confidence in the organisation and its stakeholders' capability and goodwill to commit valuable resources, such as finance and IP, to collaborate with a stakeholder, despite the risk and vulnerability that both parties may take advantage of (Child, 2001, Blomqvist *et al.*, 2005). Hence, any agreement signed between the collaborating parties should have characteristics that help cultivate trust within the relationship.

Commitment is in terms of resources and a willingness to go beyond mere contractual obligations (Wu *et al.*, 2006). In this case, commitment can either be defined as transactional (calculative) commitment or relational (attitudinal) commitment (Cullen *et al.*, 2000; Wu *et al.*, 2006). Transactional commitment consists of high levels of information sharing while relational commitment has the ability to solve conflict-like situations through a mutual win-win outlook. In addition, the People factor deals with the communication and continuous training and development issues of collaborative working (Cullen *et al.*, 2000; Wu *et al.*, 2006).

Paper 2 (Appendix B) investigated the People factor within VECW. The paper explored the prospect of fostering collaboration within SME service organisations with the help of a collaboration agreement. The paper discussed the People issues faced by ServQ by putting it in context of the literature related to trust and commitment with the actual issues in ServQ. The paper findings consisted of development of a Collaboration Charter as a collaboration agreement to try and negate some of the People issues currently faced by ServQ. The Collaboration Charter is a system for regulating collaboration while retaining flexibility to effectively harness the differences among the different collaborators.

### **2.5.2 PROCESS FACTOR**

Researchers divided processes within an organisation into operational (core), organisational (core/management) and strategic (management) processes (Maleyeff, 2006; Huq, 2005; Das *et al.*, 2000). Due to the inherent complexity of the collaborating organisations, the organisational boundaries of the collaborating stakeholders are sometimes fluid (Rittner and Gemeunden, 2003). The failure to formally describe it can lead to ambiguity and inconsistency between the collaborators.

Projects like Planning and Implementation of Effective Collaboration within Construction (PIECC) (Shelbourn *et al.*, 2005) tried to breakdown such ambiguities by developing associated processes for construction firms. However, such efforts are more related to the project-processes of a collaborative project that don't consider strategic processes at the collaboration's stakeholder level. Hobday (2000) identified organisations where the project was the primary business mechanism for coordinating and integrating all the main business functions of the firm. Therefore, there was no formal coordination across project lines. Sydow *et al.* (2004) further stated that in such organisations projects were embedded in permanent contexts, sometimes resulting in no communication of the strategic intent of the organisation. Against this background, development of a business process model can be a holistic approach to managing such organisations (Rosemann *et al.*, 2006). Particularly for service organisations like ServQ, Johnston (2008) discussed the barriers to service improvements through involvement of stakeholders, as well as, Sandhu *et al.* (2004) explained a model of process development for project-based industry.

Paper 3 (Appendix C) discussed the process issues faced by SME service organisations. The paper objective was to establish a business process model for SME service organisation. The focus of the paper being the case study organisation (ServQ), it was studied in great detail to develop a new business process model. The finding of the paper was a comprehensive business process model that took advantage of involving collaborators in all or most of the processes of ServQ.

### **2.5.3 TOOLS FACTOR**

ServQ is a management and advisory business that requires a portfolio of tools to help provide a portfolio of services such as strategy formulation, organisational alignment, partnering and alliancing. These tools help to facilitate their business and assist in providing the business services to their clients.

Establishment of collaborative working between different enterprises leads to availability of a large variety of tools within the arrangement. These tools are important resources shared in the collaborative space since SMEs are most times lacking such wide range of resources to win big projects (Das and Teng, 2000; Anand and Khanna, 2000; Hoffmann and Schaper-Rinkel, 2001; Belderbos *et al.*, 2004). Hence, tools are an important factor in collaborative



working. However, technological incompatibility along with a lack of expertise and knowledge of such tools by other stakeholders is an important potential issue of collaboration (Shelbourn *et al.*, 2005).

The concept of synergy essentially considers that value can be created by generating interrelationships across two different set of tools even on a technologically incompatible platform (Osegowitsch, 2001). The value of establishing synergies between the different tools available with the collaboration can be immense since it provides a one-stop solution to a wide variety of issues over diverse industries.

The different tools available with collaborating SMEs many times are generated for different industries. They lack a common platform and hence, the perceived synergy is hard to be converted into a one-stop solution. For e.g. Table 2.3 below describes the proprietary collaboration tools available with ServQ. These tools are not inclusive of all collaborating technologies since they consider only the techniques that ServQ used or had under their disposal.

**Table 2.3 - Desk study of proprietary collaboration tools available with ServQ**

<b>Proprietary Collaboration Tools</b>	
<b>Tool Name</b>	<b>Description</b>
BEACON	Feasibility tool - The tool essentially is used to carry out the readiness assessment of concurrent engineering with respect to the four key elements of Process, People, Project and Technology.
Implications Wheel	Strategy Exploration tool – helps to construct implications of actions and inactions by gathering information about what might occur, including the positive and negative outcomes.
Target Costing	Cost Management philosophy - The aim of Target Costing is to reduce the inherent risk of a new product development through price led costing.
Activity Based Costing (ABC)	Management Accounting philosophy - ABC is a costing system used to allocate indirect and support costs (overheads) directly to products, customers and services.
Partnership Continuum	Partnering & Alliancing tool – It provides insights into the human attributes and dynamics that make individuals successful partners through the Partnership Continuum model, which helps groups of people to create successful partnerships.
Value Management Framework	Value Management tool - The Value Management Framework (VMF) presents a framework for undertaking the VM process on projects.

Appendix D (page 181) provides an executive summary of each of these tools to give a better idea. From the description it is evident that these tools have completely different development and industry backgrounds, whilst sharing some parallel activities. Hence, resource (tool) complementarily and synergy development forms an important factor of collaborative working. For sustaining the collaborative arrangement for a long period and assist ServQ to provide best business services, all the collaborators are required to have varying level of expertise of each of these tools. The management of such training as well as associated costs and IP (Intellectual Property) issues are important to be considered in the CW context.

## 2.6 MANAGEMENT OF COLLABORATIVE WORKING

The challenges of managing collaborative working within service-oriented companies such as ServQ are unique as compared to traditional manufacturing based organisations. The inherent human condition of competing against each other combined with issues pertaining to organisational arrangements, organisational forces, conflictual situations, etc. makes it really difficult to sustain collaborative working over long periods of time. Shelbourn *et al.* (2005) correctly stated that no two collaborations are same within the same industry. As a result, each collaboration must find a way to proceed according to the circumstances it faces.

Another challenge identified by Shelbourn *et al.* (2005) is the seemingly over dependence of technology to provide answers to collaborative issues. A holistic approach of considering different factors such as processes involved and social interaction to achieve sustainable collaboration needs to be balanced with IT solutions. Among service-based organisations, another challenge is seemingly parallel services that different collaborating parties might provide individually as their core competencies, leading to increased competition rather than collaboration. Lastly, successful collaboration does have a long cycle time to show actual advantages to all collaborators and managing the collaboration until the realisation of the advantages is a real challenge.

Lu *et al.* (2007) rightly pointed out that, intellectually speaking, the basic approach to all the identified factors of collaboration may not be 'scientifically' new. Yet, their implications for an SME service firm or similar organisations with respect to individual collaborations are important for sustaining long term collaboration. In essence, all the three factors combined together to form a complex process-based socio-technical system of collaboration.

## 2.7 SUMMARY

This chapter intended to provide a brief view of the different literature available under the umbrella term of collaboration. Further literature was explored specifically regarding the collaborative working within SMEs. This led to a discussion on the potential benefits of collaborative working as well as the issues currently faced when getting involved in collaborative working. These benefits and issues needed consideration in relation to the value attributes of each stakeholders. Section 2.4 discussed these value attributes that the stakeholders were guided by when working within the collaborative arrangement.

Numerous researchers have identified factors for collaborative working within an organisation (Prasad, 1996; Austin *et al.*, 2001; Khalfan, 2001; Shelbourn *et al.*, 2005). These researchers make a distinction of three important factors responsible for collaborative working in People, Processes and Tools. These factors when studied in isolation provide an insight into the different aspects of collaborative working that needs to be considered to solve some of the issues identified previously. Management of collaborative working would require a balanced approach of all these three factors to focus on all aspects of collaboration. The next chapter will provide an insight into the research methodology adopted for the doctorate research.

### 3 RESEARCH METHODOLOGY

#### 3.1 OVERVIEW

A research methodology provides a strategy to conduct research by following a methodical route that is outlined taking into consideration the suitability for the current research work. Hence, this chapter is a discussion on the chosen research methodology with respect to the specific aims and objectives of this research. A research methodology defines what the activity of research consist of, how to proceed, how to measure progress, and what constitutes success through the researchers' ontological or epistemological views (Creswell, 2003).

#### 3.2 RESEARCH METHODOLOGIES

The research methodology adopted for the current research had to consider the fact that research was conducted in a commercial environment of ServQ. The research's overarching aim and its objectives (see chapter 1) set out by the combination of the academic and industrial sponsor's expectation of the research, meant that the research was clearly categorised as applied research as opposed to theoretical research. A range of different methodologies are available to investigate a research problem, all of which can be categorised in different ways. However, classification of a research in particular category is hard, due to the use of different definitions and, more importantly, since the research work occurs in a continuum (Fellows *et al.*, 2006). The methodology selected should make clear the reasons for choosing a particular research strategy.

One of the most common ways of differentiating between research approaches is in terms of 'qualitative', 'quantitative' and 'triangulation'. Burns *et al.* (as cited by Cormack, 1991) define quantitative approach as "a formal, objective systematic process in which numerical data are utilised to obtain information about the world." The quantitative method seeks to gather factual data in order to study relationships between facts, and how these relationships accord with finding and theories of previous studies and research. Therefore, for this purpose, scientific techniques are used to obtain quantified data which are evaluated in the light of existing knowledge (Bryman *et al.*, 1990).

According to Creswell (2003), a qualitative methodology is a procedure for a qualitative study that includes advancing the assumptions of qualitative designs, indicating the specific type of design, reflecting on the researcher's role, discussing data collection, developing data recording procedures, identifying data analysis procedures, specifying verification steps, and presenting the narrative outcomes of the study.

Research approaches can be based on either qualitative methods or quantitative methods or the combination of both called the triangulation method (Fellows *et al.*, 2006). A combination of qualitative and quantitative methods is called triangulation, where theories can be developed qualitatively and tested quantitatively. It allows the researchers to gain insights and results to assist in making inferences and in drawing conclusions (Denzin as cited by Cormack, 1991).

In addition to the above style of research approach differentiation, there are a number of other research approach classifications. Fellows *et al.* (2006) stated the principal research approaches as 'Experimental', 'Survey', 'Action' and 'Ethnographic'. According to Dainty (2005), another way of research approach differentiation is 'Positivist' (scientific),

‘Interpretative’ (phenomenological) and ‘critical’. Whilst, Brymann *et al.* (2003) and Gill *et al.* (2002) like to differentiate research approaches as ‘deductive’ (nomothetic) and ‘inductive’ (ideographic) approaches. Table 3.1 provides brief explanations of some of these research approaches to understand them.

**Table 3.1 - Research approaches explanation**

Research Approach	Explanation
Experimental research	Experimental research is an attempt by the researcher to maintain control over all factors that may affect the results of an experiment (Fellows <i>et al.</i> , 2005)
Survey research	A survey can consist of a short form or it can be an intensive one-on-one interview (Trochim and Donnelly, 2007). The main weaknesses of survey research are reliance on respondents to be honest and accurate in their responses, and the inability of survey research to deal with complex social phenomenon (Baker, 2003).
Action research	Action research is a process where the researcher actively participates in the process under study, in order to identify, promote and evaluate problems and potential solutions.
Ethnographic research	Ethnography is a research approach based on the study of a culture by a researcher. It is founded on the personal interaction and experience of the researcher through fieldwork and typically employs three types of data collection: interviews, observations and documents, which results in a narrative description (Brymann <i>et al.</i> , 2003).
Positivist research	Positivist research looks to discover laws and generalisations that explain reality and allow for prediction; explaining events or phenomenon through knowable facts and measurements (Woods and Trexler, 2001)
Interpretative research	Here the focus of research is based upon understanding and interpreting occurrences and social structures to provide a meaning to the phenomenon (Woods and Trexler, 2001)
Critical research	Critical research tries to question the truths about subjectivity, experience and the way the world is combined with recognition of the cultural, political and historical factors which shape experience.

As the research in question deals with the domain of management, it is dependent upon the theories in social science since it helps increase the understanding of how organisations work, and their impact on individuals related to these organisations (Lupton, 1971; Brymann *et al.*, 2003). Since Brymann *et al.* (2003) and Gill *et al.*’s (2002) classification of research approaches is based on the social science research perspective, deductive and inductive approaches were examined in further detail to facilitate a decision on the most appropriate research approach for the completion of the current research work.

### **3.2.1 DEDUCTIVE APPROACH**

A deductive (also known as nomothetic) research approach entails the development of a conceptual and theoretical structure prior to its testing through empirical observation (Gill *et al.*, 2002). According to Popper (1967) and Brymann *et al.* (2003), the source of the theory here is of little significance, but the logic of deduction and the testing of the theory is important. Deductive research approaches are characterised with preoccupations of measurement, causality, generalisation and replication based on the natural science model (Brymann *et al.*, 2003). This condition exhibited that deductive approaches are mostly entrenched in the quantitative research type (Barratt *et al.*, 2010).

The nature of the research problem for the current project can be classed as ‘open’ and complex, requiring a dynamic approach to understand the research problem in more detail in the initial stages of the project. The research problem here was to get an objective appraisal of VECW in ServQ, which is a dynamic SME service organisation, by the virtue of factors responsible for CW in ServQ. Hence, there is no hypothesis based on theory suggested at the onset. In addition, the current project is based in an organisation and hence the variables are not standardised in a controlled environment. Both situations above demonstrated that the research does not follow a deductive approach.

### **3.2.2 INDUCTIVE APPROACH**

An inductive (also known as ideographic) research approach draws on the generalisable inferences out of observation (Brymann *et al.*, 2003). Hence, in simple terms, theory is an outcome of research. An inductive approach to research begins when specific observations from a variety of studies are used to identify a general, overarching pattern. That pattern is then used to approach a general theoretical perspective, or to modify an existing perspective, that accounts for the observations. This research approach is pertaining to contextual understanding of a phenomenon, as in why and how a particular phenomenon occurs (Brymann *et al.*, 2003). For the current research work, a highly inductive approach would involve recording all behaviours through active day to day participation.

### **3.2.3 DEDUCTIVE - INDUCTIVE CONTINUUM**

There is a possibility to construct a continuum of research methods that allows the differentiation between different methods (for e.g. Fellows *et al.*’s laboratory experiments, surveys, action research and ethnography) in terms of the various logics they bring to bear in conducting research (Gill *et al.*; 2002). The extremes of this continuum are deductive and inductive methodologies.

Figure 3.1 shows the comparison between nomothetic and ideographic methods. Here, deductive methodologies have an emphasis upon quantifiable observations that lend themselves to statistical analysis (Remenyi *et al.*, 1998). Whereas inductive methodologies (Brymann *et al.*, 2003) emphasise the analysis of subjective accounts that one generates by ‘getting inside’ situations and involving oneself in the everyday flow of life.

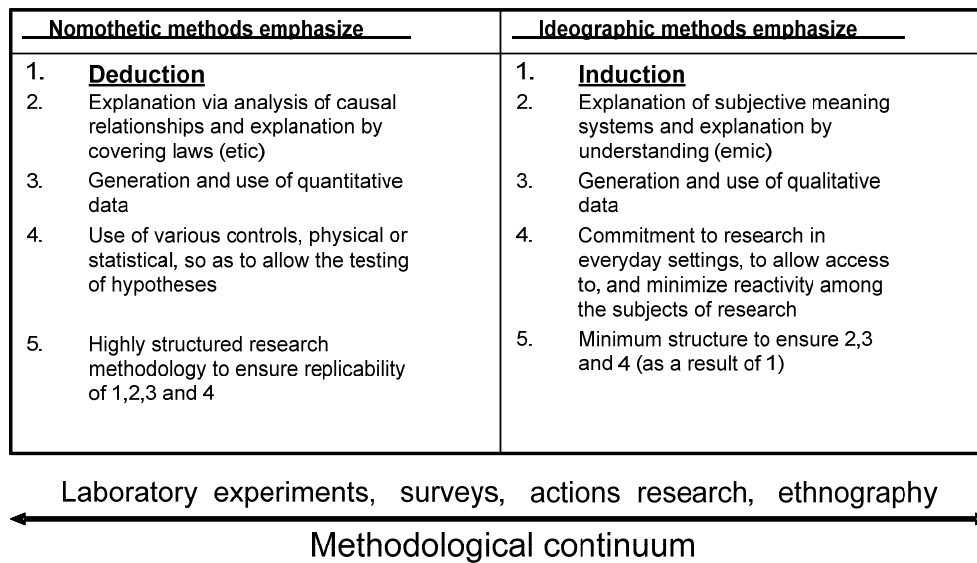

**Figure 3.1 - A comparison of deductive and inductive research approaches (from Gill and Shodhan, 2002)**

Considering these methodological ideologies as two ends of a continuum, the research method was divided into four types (see Figure 3.1). These different research methods are reflective of highly experimental thinking on one side to highly ethnographical thinking on the other.

In the current project, the emphasis needs to be on a research method which is committed to the smooth working of ServQ, in this case a management advisory firm. A major portion of the research was based on the understanding of the issues faced by the organisation through the eyes of ServQ and how to interpret that data into factors that help sustain long term collaboration. Hence, on the methodological continuum a method which is inclined towards ideographic ideas was considered more ideal for the project.

### 3.3 DATA COLLECTION METHODS/TOOLS

The research approaches discussed in the previous section will require different data collection methods. A data collection method can be defined as the techniques which will be used to collect evidence and which would influence the way in which that evidence will be analysed (Remenyi *et al.*, 1998). Numerous research (Remenyi *et al.*, 1998; Brymann *et al.*, 2003; Dainty, 2006; Fellows *et al.*, 2006) provide a list of basic methods for evidence collection and analysis. Some of these methods were used in the current research such as :

- Case studies

Yin (1989) defines case study as an inquiry of a phenomenon in real life context, where multiple sources of evidence are used. It is a research method that focuses on individual cases. The focus of the case study is to understand the particulars of a case through the actual interaction of variables or events (Remenyi *et al.*, 1998). However, case study is an umbrella term consisting of wide range of evidence capture and analysis procedures with many orientations falling under its domain.

- Questionnaires

Questionnaires can be open or closed. Open questions are prepared to help the respondent to answer in full (Fellows *et al.*, 2006). These questions can be difficult to answer and analyse. In contrast, close questions have a preset number of responses. A good practice in questionnaire preparation is to conduct pilot studies, to ensure that the questions are intelligible and unambiguous. Questionnaires were used in the current research to provide fast responses to certain questions as well as help evaluate the research.

- Interviews

Interviews can vary in nature from structured to semi-structured to unstructured depending on the constraints of the researcher as well as the respondent (Fellows *et al.*, 2006). Structured interviews are conducted to ensure that all interviewees are given exactly the same context of questioning (Brymann *et al.*, 2003). Questions are usually very specific in such interviews. In unstructured interviews, the interviewer has only a list of topics or issues (an interview guide) and the style of interviewing is informal (Brymann *et al.*, 2003). In contrast, semi-structured interviews are anything between these two extremes. Semi-structured interviews were used during different research stages of the current work. For e.g. in the preliminary stages of the research, conversational interviews were held with the senior management of ServQ to find out how ServQ works. The questions were open and adapted based on the responses of the interviewee. In contrast, for each of the factors, specific open-ended semi-structured interviews were conducted.

- Thematic analysis

The thematic analysis consists of scrutiny of different types of documents, transcribed texts of interviews, etc, so that the content can be analysed to establish the meanings, intentions, interpretations, etc. of the people concerned (Fellows *et al.*, 2006). The simplistic use of thematic analysis is to determine the main aspects of a set of data, by counting the frequency of a topic within a document. Thematic analysis is a process of reducing data into meaningful groups after the inspection of the raw data.

- Participant observation

The participant observation method requires the researcher to join a team of people that constitute part of the phenomenon being studied (Remenyi *et al.*, 1998; Brymann *et al.*, 2003). According to Brymann *et al.* (2003) participant observation can be conducted in four ways depending on the day-to-day involvement of the researcher in the organisation as explained in Figure 3.2. The current research setting ensured that the researcher was in an Observer-as-Participant role as, he was employed by ServQ to undertake this research project. However, for certain client specific work, the role was changed to a more Participant-as-Observers role.

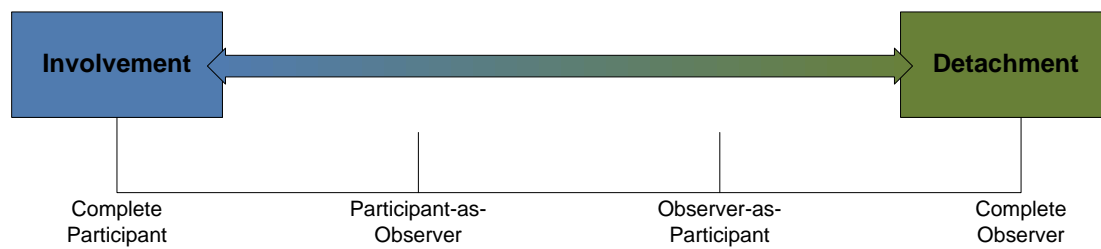

**Figure 3.2 - Classification of Participant Observation roles (from Brymann *et al.*, 2003)**

- Focus Groups

Focus groups are a form of group interview with several participants (usually more than four) with the focus on the interaction within this group (Brymann *et al.*, 2003). Remenyi *et al.* (1998) indicates the extensive use of focus groups for evidence collection within a single project in management research as well as its use as a method for end-user evaluation. In the current project, this method was mainly utilised for evaluation purposes.

- Scenario planning

Scenario planning is a research method used for decision making in complex and uncertain environments (Bradfield *et al.*, 2005). The use of this technique can help elicit the implications of a particular hypothetical situation (Van der Heijden, 1997; Remenyi *et al.*, 1998). Scenarios are well written stories that are internally consistent, carry storylines expressed in simple diagrams and are plausible (Van der Heijden, 1997).

The research objectives were based on the requirements of ServQ. This was because the EngD program requires the research to make a significant contribution to the performance of the organisation. Hence, a method leaning towards an inductive approach was adopted where the nature of the project ensured that observation and involvement of the researcher in the everyday working of the organisation was possible. The methodological background for specific research methodology is discussed in the next section.

### 3.4 METHODOLOGICAL BACKGROUND

The involvement of ServQ meant that the research had to appreciate and address the industrial sponsor's requirements and expectations. Periodic feedback from ServQ through the industrial supervisor was considered as an important aspect throughout the four year span of the study. Active participation in ServQ projects by the RE ensured an active role in ServQ to get a first hand experience of the managerial issues of CW within ServQ.

ServQ wanted the focus of the research project to be on developing an overarching tool. This tool should integrate the different tools and techniques that ServQ currently possess (those developed in house or licensed). Whilst ServQ was clear on the primary aim of the research to be conducted, certain changes to the focus of the research had to be considered based on a preliminary study. Once the preliminary study was conducted, it was found that the research had to consider other factors for performance improvement to substantially enhance value of CW in ServQ. Hence, even though the project was an applied research, it was based on the sound foundations of the available theories on CW. The approach of the research was ideographic, however several data collection and analysis methods were used within the different objectives of the research as evident from the Table 3.2.



**Table 3.2 - Research methods used**

Table 3.2 - Research methods used			Research Data Collection And Analysis Methods						
Objectives	Description	Project Deliverable	Literature Review	Semi-structured Interviews	Focus Groups	Organisational Documents	Thematic Analysis	Scenario Planning	Report Writing
1	To review related work in CW and Value including existing tools and techniques.	Paper 1	P	S	S	P	S		S
2	To investigate patterns of CW within ServQ, and to identify areas of process improvements.	Paper 1	S	P		S	P		P
3	To further investigate the identified concern areas for process improvements in isolation.	Papers 2,3	S	P	P	S	S	P	P
4	To develop a comprehensive framework to enhance CW.	EngD Thesis	S	S	P		S	S	S
5	To discuss the managerial implications of the research.	EngD Thesis	S				S	S	P

Key

P = Primary Method	S = Secondary Method
--------------------	----------------------

The next section further describes the adopted research methodology with respect to the individual objectives of the research.

### 3.5 ADOPTED RESEARCH METHODOLOGY

The research methodology evolved as the project progressed. The primary aim of the project was to investigate the potential of Value-Enhanced Collaborative Working in an SME management advisory firm. In order to satisfy this aim, the research project had five objectives, each with individual deliverables. The nature of the project meant that different approaches were needed to be adopted to meet the individual project objective.

#### 3.5.1 UNDERSTAND THE FOUNDATIONS OF CW AND VALUE WITH RESPECT TO SME SERVICE INDUSTRY

The commencement of literature review was subsequent to the review of the industrial sponsor’s strategic long-term goals and ServQ’s website to understand the current business priorities of ServQ and its concerns. This resulted in identifying the focus areas of research and the objectives of project. The first objective of the project was to review the existing literature on three distinctive areas. The first area was a review on CW practices. The general

collaborative working literature from publications and books was reviewed, followed by the specific CW literature on service organisations as well as CW literature on SMEs. The second area was review on value and values. Finally a review of the tools and techniques for CW available with ServQ was carried out based on their project reports, published books on the tools, tender documents and by attending workshops.

### **3.5.2 INVESTIGATE PATTERNS OF CW WITHIN SERVQ TO IDENTIFY AREAS OF PROCESS IMPROVEMENT**

The focus of the second objective was to identify CW patterns within ServQ and identify specific areas of process improvements within ServQ. It was achieved with the help of semi-structured interviews with Directors of ServQ, ServQ Associates and its Clients. The themes of the questionnaire consisted of questions on the process of CW in ServQ examples of ServQ's business processes (e.g. what was the standard bidding process) motivations for CW and knowledge of the portfolio of tools that ServQ procured. The themes were directly related to the three distinctive areas of literature review carried out in objective 1 (i.e. CW working practices covered through ServQ's business processes; value studies related to the motivations of CW in ServQ and current CW tools that ServQ possess).

The patterns of CW within ServQ were understood by collecting relevant information (e.g. the collaborative arrangement between the different collaborators and communication channels) from the stakeholders of ServQ with the help of semi-structured interviews. The semi-structured interview questions were developed by asking questions broadly and then asking further questions to understand a particular section in detail. The interviewees were encouraged to illustrate, through examples, the barriers for existing collaboration within ServQ and the underlying reasons behind them. For example, an Associate was asked to explain the collaboration model of ServQ with the help of processes involved in a project carried out with ServQ. Understanding the attitudes and values of each of the ServQ stakeholders was important for attaining the second objective since the individual values of stakeholders, if similar to ServQ's values, would positively influence the collaboration. The semi-structured interview provided the required level of depth, while keeping a suitable level of control over the running of the research (Easterby-Smith, 1991; Silverman, 2004).

Each interview was recorded and then transcribed, resulting in identification of key points within each question (see Appendix E, page 203 for the preliminary questionnaire). Analysis was carried out thematically and the patterns of collaborative behaviour were built up within the transcript to enable development of a conceptual framework. This analysis assisted in reviewing the appropriateness, intervention need and acceptability of the enhanced value through collaboration amongst the interviewees. The result of this synthesis is the identification of a set of central themes that would enable or incapacitate performance improvement of ServQ. Themes that emerged from the interviewees' stories are pieced together to form a comprehensive picture of their collective experience of CW in ServQ. The findings were substantiated from within the services and SME sector.

### **3.5.3 FURTHER INVESTIGATE THE IDENTIFIED CONCERN AREAS FOR PROCESS IMPROVEMENT IN ISOLATION**

The focus of the study for the third research objective shifted from the overall picture of CW within ServQ to specific areas of process improvements. Hence, a detailed case study was undertaken to investigate each of these process improvement factors (identified as People, Process and Tools).

Third objective was achieved using three distinctive projects. The work carried out in each of these projects was done iteratively and simultaneously since each of these factors were unique with respect to the issues faced by ServQ such as communication related issues in people factor, clear process ownership in process issues and a lack of understanding of different tools. Hence, the case study method helped to focus the attention on each of these particular issues within ServQ. The People factor was studied by collecting data through one-on-one meetings with ServQ and its collaborators. ServQ signed a standard partnership agreement with Associates before embarking on a project. To understand the current agreement, a questionnaire was developed and sent to all the Associates in addition to the one-on-one meetings. Themes within the questionnaire were broadly divided into four parts consisting of: a) personal details of the Associates including their core competencies and industry experience; b) issues and expectations of the partnership agreements; c) details of different projects carried out and knowledge of Associates regarding ServQ technology; and d) communication within the collaboration. The analysis of the questionnaire highlighted issues of collaboration in ServQ. Based on the results, a new Collaboration Charter was introduced and evaluated at a ServQ strategy workshop.

The Process factor was dependent on the multiple inputs of the people involved in the case study. Individual interviews as well as participation in group meetings were used to gather information on the current processes of CW, the resource distribution while working on a collaborative project, ownership of processes and the management as well as people issues while working with ServQ. The group meeting was part of a internal organisational strategic workshop. This technique ensured participation from both operational (collaborators) as well as strategic (directorial) level of the CW arrangement. The result of this exercise was an 'As Is' model of ServQ's collaboration. A new process model was developed based on the requirements of ServQ and its collaborators by involving the practitioners in the definition of the processes. The processes ensured that the expectations of ServQ Directors and the Associates were communicated with each other to understand the processes from a holistic point of view.

Lastly, the Tools factor required a method of understanding the synergies between the tools and techniques for CW within ServQ for different situations. A scenario planning exercise was considered to augment the understanding of how the synergies between tools can be useful for ServQ. These scenarios were not considered as projections, predictions or preferences; however they were coherent and credible stories that described alternative futures. Alternative scenarios were generated for projects that ServQ did bid for to generate solutions for clients with the help of different set of tools already available within ServQ's portfolio. This exercise helped in identifying how different tools can be combined to reach the same solutions with the help of different tools. In return, the collaborators of ServQ need to decide on a solution, that is economically viable, preferred by the client and easy to execute. Hence, the lessons learned from the exercise would be helpful in identifying possible tools gap as well as tools knowledge requirements within ServQ's collaborators to successfully complete the project with the clients.

### **3.5.4 TO DEVELOP AND EVALUATE A COMPREHENSIVE FRAMEWORK TO ENHANCE CW**

The previous objective developed each of the factors identified along with their respective mechanisms to ensure better CW in ServQ. This objective was concerned with bringing the factors together with its mechanisms to provide structure to the comprehensive framework. It

was important to find out the usefulness of the VECW framework. Hence, evaluation of the framework was an important objective. This objective is concerned with the evaluation of the effectiveness of the interventions designed in the previous objective. The essential aim of evaluation was to see if the issues related to CW in ServQ are solved in its entirety.

The evaluation was carried out in two stages: preliminary evaluation and user-centric evaluation. The research method for the evaluations was the use of focus groups. The focus groups were given a workshop presentation to explain VECW framework followed by a questionnaire for them to complete. The preliminary evaluation focus group consisted of researchers from Loughborough University working in the related fields of VECW. Feedback received from the preliminary evaluation also informed the changes required for the workshop presentation and the questionnaire to improve the evaluation process. The preliminary evaluation helped to identify whether the framework had general understability as compared to the final evaluation which was from an end-user perspective. The user-centric evaluation was carried out with a focus group of the ServQ stakeholders.

Table 3.3 on the next page categorise the themes of the evaluation questionnaire along with their mode of identification.

**Table 3.3 Identification of themes for evaluation**

Theme	Identified through
People factor mechanism	Based on the people issues and the use of Collaboration Charter as a mechanism to solve those issues
Process factor mechanism	Based on the process issues and the use of IDEF0 business process model as a mechanism to solve those issues
Tools factor mechanism	Based on the synergy of tools issues and use of scenario planning exercise as a mechanism to solve those issues
Overall framework effectiveness	The combined effectiveness of the VECW framework based on the benefits and concerns identified for the framework in its entirety.

Lastly, evaluators were asked to answer open ended questions to generate qualitative data. This data was analysed to suggest:

- Overall benefits of the VECW framework;
- Improvements to the VECW framework;
- Barriers to VECW framework implementation; and
- Additional factors that were needed to be covered for ServQ’s collaborative working.

### **3.5.5 TO IDENTIFY THE MANAGERIAL IMPLICATIONS OF THE RESEARCH**

This objective is concerned with the development of a guide to ensure a sustainable long-term collaboration in ServQ. It discusses the managerial implications for each of the factors identified in the framework from operational (short term), organisational (medium term) and strategic (long term) point of view. The guidelines of VECW framework were prioritised in each of the sections to give a better roadmap to ServQ for implementation. The implications of the research at this stage are more concerned with ServQ. Lastly, a research synthesis stage consisting of the writing up of the EngD thesis was required.

### **3.6 SUMMARY**

This chapter has provided a discussion on the research methodology adopted for the EngD research project. It started with a detailed description of the different research approaches and was followed by the reasons for adopting particular research methods to achieve the objectives of the research. The next chapter will discuss the actual research work undertaken during the research period.



## **4 RESEARCH UNDERTAKEN AND FINDINGS**

### **4.1 INTRODUCTION**

In order to achieve the research aim introduced in Chapter 1, the research objectives were divided into three main sections. The first section identified the areas that required attention for improvement in collaborative working. This was established through a conceptual framework of VECW based on previous research and the requirements of ServQ (research objective 2). The second section established the factors responsible for CW by examining individually in further detail. This section required each of the factors identified in the conceptual framework to be researched in greater detail by finding issues ServQ faces within those factors and develop mechanisms against those issues. The last section was the evaluation of the framework developed after the examination of all the factors within the framework (research objective 4). This chapter covers the first, second and third objectives (described in Chapter 1) in detail, outlining the preliminary studies undertaken, the subsequent work packages being carried out and the findings that were established. Hence, the main items researched were as follows:

- VECW conceptual framework (output - Paper 1, Appendix A)
- People factor (output – Paper 2, Appendix B)
- Process factor (output – Paper 3, Appendix C)
- Tools factor (output – ServQ internal report)
- Evaluation of framework (output – Paper 4, under development)

Figures 4.1 (a) and (b) show the development of each of these main research items based on the individual objectives followed by the academic outputs produced from the research work. This chapter provides further details on each of these tasks.

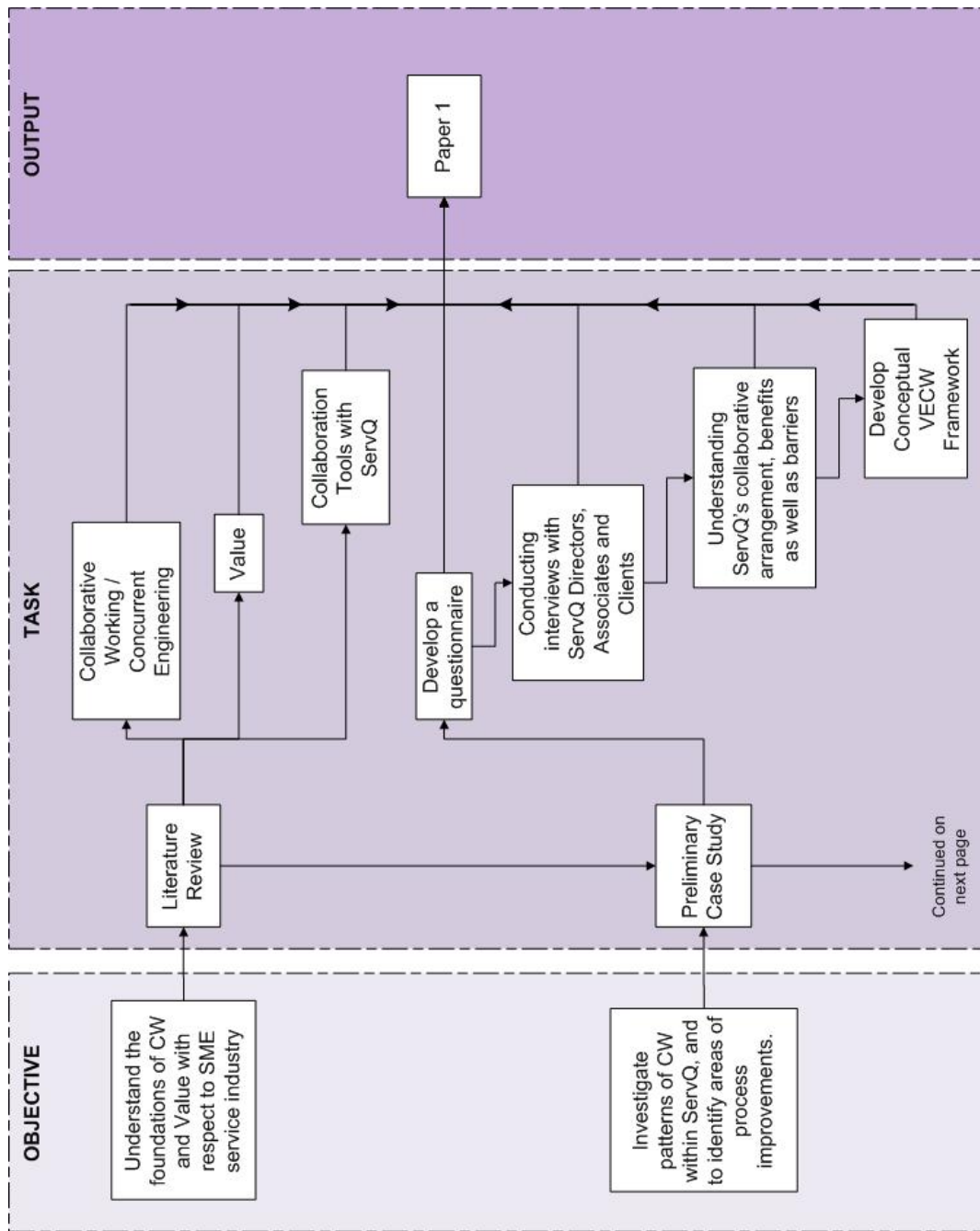
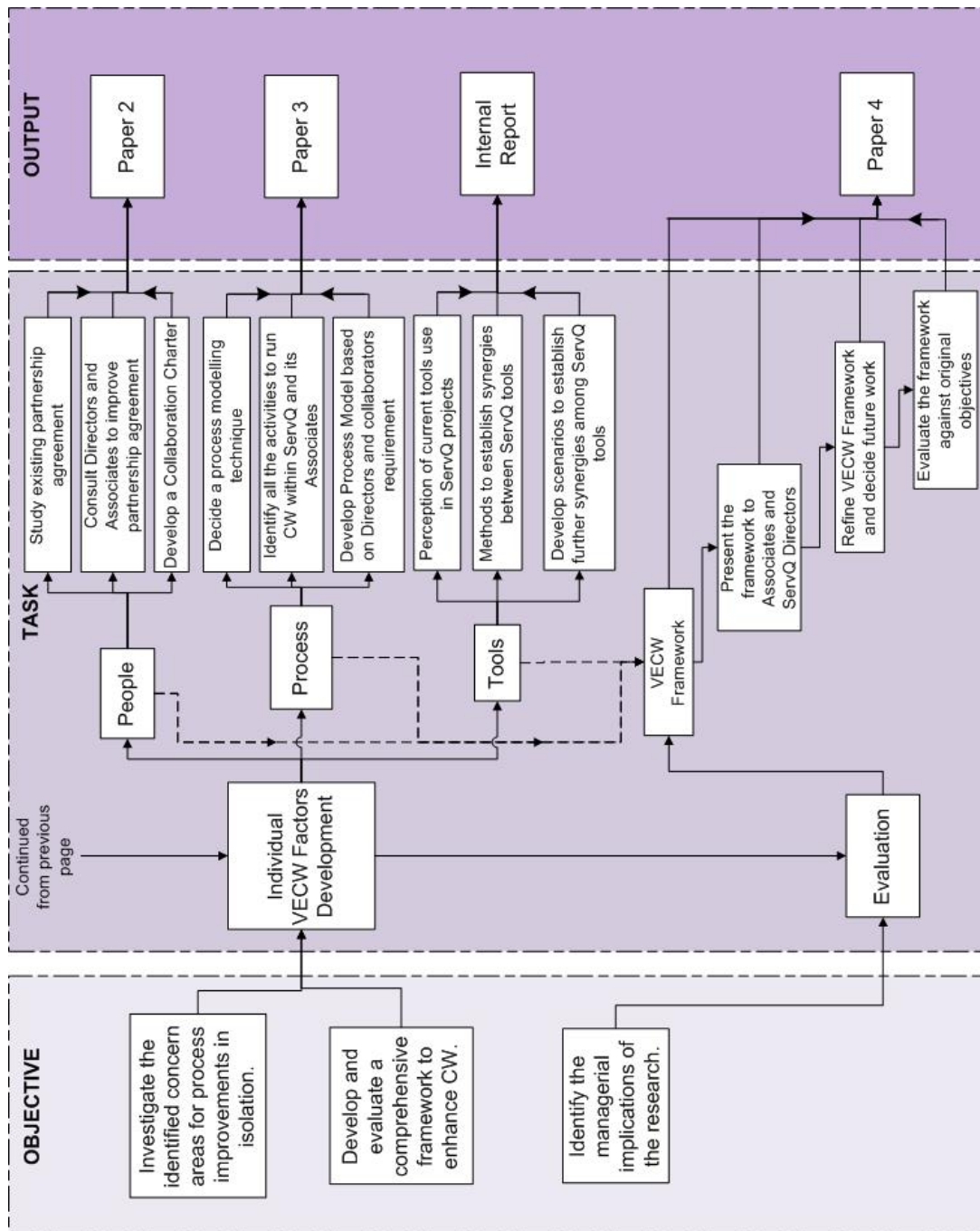

Figure 4.1 (a) - The research development process (objective 1 and 2)





**Figure 4.1 (b) - The research development process (objective 3,4 and 5)**

Research during the preliminary months of the project was mainly aimed at understanding ServQ’s working practices. This period of initial investigation entailed learning about the organisation’s management and working culture and was facilitated by participating in the various internal business activities such as strategic workshops, training and new project kick-off meetings. During the course of the research duration, these were all key activities that assisted in putting the research in the context of the organisation and addressing the research objectives. Early involvement of organisational employees of ServQ was important since the research work was supposed to directly affect their working practices. Since ServQ is a very small organisation, the research work was discussed at each stage with all the three directors of the organisation. Such communication helped to drive the findings within the organisation and to integrate them in future ServQ processes.

## **4.2 ESTABLISH A VECW DEFINITION**

The initial part of the research was to establish a VECW definition as well as a conceptual VECW framework. It was important to first identify the current way of working to understand the requirements of ServQ. Hence, this stage established the existing patterns of working within ServQ and enabled the necessity of changes required in ServQ's way of working as well as how ServQ's collaborative arrangement would be managed. This formed the basis of Paper 1 (Appendix A).

### **4.2.1 DETERMINE THE REQUIREMENTS OF VECW**

The value of good collaborative working can be enhanced only if the requirements of the organisation are determined in advance. A wide variety of reasons can be responsible for the need to develop a mechanism for streamlining collaborative working in ServQ. The first year of the research was dedicated to achieving this understanding of the requirements. During this period the researcher was involved in undertaking qualitative interviews with all the important stakeholders in the collaborative working relationships of ServQ. These stakeholders consisted of three directors, two Associates and two members of a client organisation of ServQ. The interviews were part of the preliminary studies to document the issues with the current working culture within the organisation.

The interview questions were designed to facilitate the understanding of the backgrounds of each of these participants and how they fit into the organisational setup. The interview questions further divulged the working practices of the organisation, the objectives of the collaboration and personal motivation of the different stakeholders to be part of the collaboration. Lastly, it also dwelled on the advantages and limitations of the current arrangement from the interviewees' perspective.

The key finding of this exercise was that Associates and Strategic Partners had little incentive to generate new business for ServQ. Hence more incentives through process changes should generate more business leading to VECW over a sustained period. The exercise also made clear that the vision of the directors of ServQ was not always shared by the Associates or sometimes the Associates were unaware of the overall vision of this collaborative arrangement. Lastly, across the collaborating Associates, there was a mismatch of competency levels and knowledge of collaboration tools available with ServQ.

The researcher presented a summary of these findings in a report to ServQ's Directors to discuss and proposed initial recommendations such as development of a framework of major factors responsible for CW in ServQ. These discussions with the Directors helped estimate the impact of the above mentioned issues on the collaborative working of ServQ and its success. In addition, these discussions helped prepare the base-work for the conceptual framework of VECW.

Considering the above, VECW was defined by the researcher here as the collective work of two or more individuals, teams or organisations, undertaken with a strong commitment to enhance the value derived from a collaborative enterprise. It includes key concepts of partnering and alliancing, using technology driven tools as appropriate, and managing systematic social interactions in order to achieve a common understanding between collaborative teams.

#### **4.2.2 IDENTIFY VECW FACTORS TO DEVELOP A CONCEPTUAL FRAMEWORK**

To identify the VECW factors, exploratory observations were carried out. The exploratory observations were conducted in order to understand the mechanisms for collaboration in ServQ and its collaborators. These observations helped to identify ServQ's ability to generate business and the value generated by the collaboration for ServQ as well as the collaborators. Initial observations highlighted that in ServQ:

- Limited business was being generated by collaborating parties;
- Limited financial/business value was being derived through collaboration; and
- There was poor communication between ServQ and its collaborators.

Following the initial observations, a detailed case study was undertaken. Semi-structured interviews investigated how current practices were responsible for the issues highlighted and identified factors that affect collaborative working within ServQ. Analysis of the interviews identified central themes responsible for performance improvement in ServQ and its collaborators as:

- Collaborative working;
- Information transparency; and
- Communication.

Further analysis revealed how these three themes were affected when ServQ and collaborators attempted to win projects or work on existing projects. This analysis also illustrated the expectations of ServQ and its collaborators from their collaborative arrangement through all stages of project work. By comparing and contrasting the findings of the literature review and the case study, it was possible to tease out the key components of VECW, which subsequently led to the development of a conceptual VECW framework. Paper 1 (Appendix A) provides a detailed analysis of the ServQ's case study resulting in identification of issues related to People, Processes and Tools, leading to the existing collaborative arrangement. Based on the issues, Paper 1 provides a conceptual VECW framework to assist ServQ and its collaborators.

The components of the conceptual VECW framework address the collaborative issues in further detail. The conceptual framework was deemed necessary since it helped to generate scientific evidence in a structured manner to further analyse each component present within this framework for better VECW. The majority of collaboration issues could be divided into three major issues i.e. Processes, People and Tools. Researchers such as Prasad (1996), Austin *et al.* (2001) and Khalfan (2001) suggested similar factors to control the character of an organisation in their studies. Hence, the conceptual VECW consists of these three factors as shown in the Figure 4.2 below.

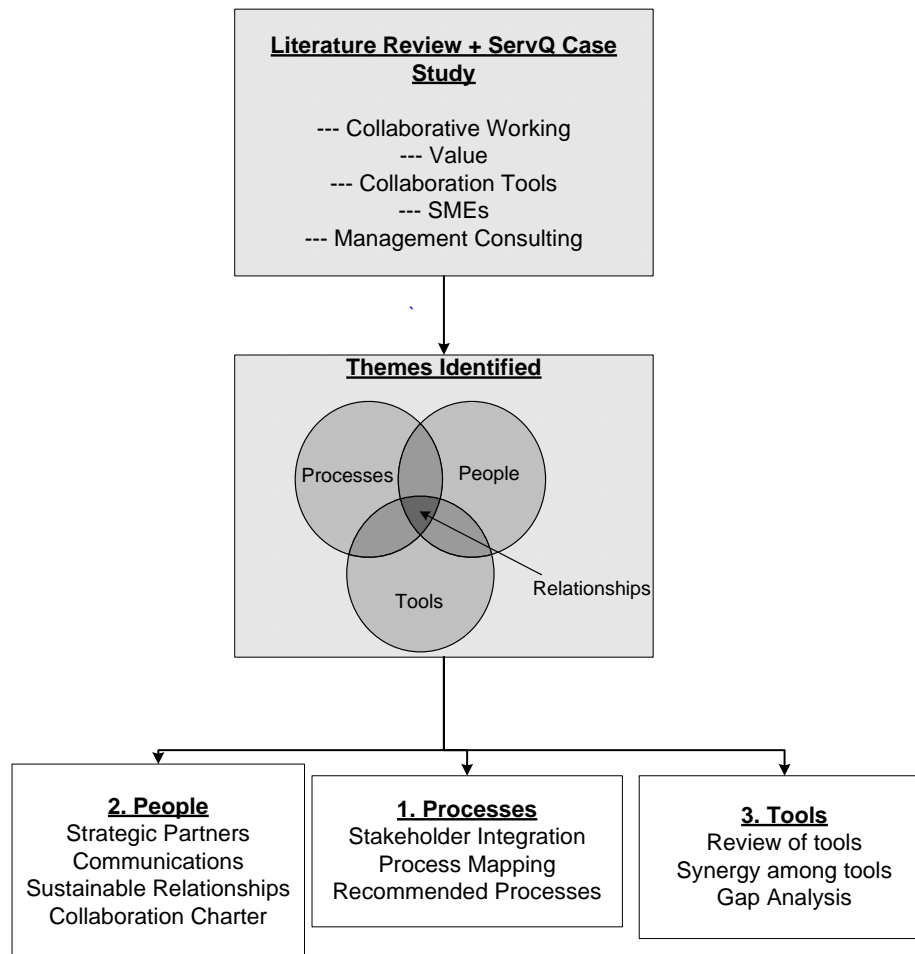

Figure 4.2 – Conceptual VECW Framework

The conceptual framework is the direct result of the analysis of literature review as well as ServQ’s case study. The themes developed after the analysis formed a Venn diagram consisting of all three factors. These factors are important to be understood in isolation. However, they need to be viewed in context with the other factors to establish the VECW framework. The conceptual framework identified the VECW factors as well as the components of each of these factors for further investigation.

#### 4.2.3 SUMMARY OF VECW CONCEPTUAL FRAMEWORK

This stage of the research carried out the preliminary investigations to identify the important factors that are part of VECW. However, the identification of the important factors alone will not yield performance improvement in ServQ’s collaborative working. To add value to the collaborative arrangement will require identification of the extent of improvement in each of these VECW factors. Although literature (Shelbourn *et al.*, 2005) from construction industry suggested that people and process factors are more important in collaboration as compared to technology, the current research considered all the three factors equally important. This decision was in line with the feelings of ServQ directors and collaborators who felt that each factor plays an important role in service firm collaboration. These would be carried out by individually considering each of the factors and identifying the approach of aligning them with VECW. Hence, this section concluded the objective 2 of the research and led to objective 3. However, the next section will consider each of its factors in further detail as

three separate but equally important branches that together will create a sustainable, long-term, collaborative working environment and enhance the value of such an arrangement.

### **4.3 PEOPLE FACTOR**

The people factor was the basis for Paper 2 (Appendix B). The importance of the People factor for ServQ was recognized during the establishment of the conceptual VECW framework. However, it is important to further examine the People factor to ascertain what part it plays in the collaborative working within ServQ. The research carried out for the People factor for ServQ was published as paper 2 (Appendix B). The paper discussed how collaborative arrangements can be fostered within SME service organisations like ServQ through the help of a Collaboration Charter. It essentially develops a system of regulating the social construct of collaboration while retaining flexibility to effectively harness the differences among the different collaborating stakeholders.

Team composition, based on the team member's personality traits, is important and noted in several articles (Driskell *et al.*, 1987; Mount *et al.*, 1998; LePine *et al.*, 2000). This is because the individual thoughts, feelings and behaviours that are reflected in the individual's behaviour are not always relevant on the project but can still affect it. However, for an SME organisation, there is not always a wide range of team-members available to choose from. In addition, the sponsors had in place selection criteria for team members that according to ServQ facilitate team interaction and performance achievement based on the individual skills, knowledge and attitudes of the team members.

#### **4.3.1 APPROACH FOR ALIGNING THE PEOPLE FACTOR IN VECW**

A review of literature was helpful in finding prospective mechanisms to establish the People factor in VECW. ServQ's partnership agreements are responsible for the development of the different elements of the people factor within the collaborative arrangement. Such partnership agreements are a means of ensuring the share of capital, skills, technology, IP, protection from opportunism and sustaining long-term relationships (Frankel *et al.*, 1996; Yli-Renko *et al.*, 2001). It has already been established that the human bounded rationality creates issues with long-term agreements as the uncertainties lead to incomplete agreements (Hart and Moore, 1999; Maskin and Tirole, 1999).

Successful collaboration requires extensive commitments over a long period of time. Hence, there needs to be sufficient complexity in these collaboration agreements to understand the reasons for different stakeholders to enter the collaboration and communicate the aims and objectives while providing sufficient flexibility to the stakeholders (Rousseau, 1995).

In view of the literature, the RE (Research Engineer) felt the need to examine the existing partnership agreement and propose changes to it, to ensure all the aspects of the People factor are considered under the new partnership agreement (Collaboration Charter). Hence, the Collaboration Charter becomes the mechanism for promoting the People factor within the collaborative arrangement.

#### **4.3.2 EXAMINATION OF EXISTING PARTNERSHIP AGREEMENTS**

The existing partnership agreement was a legally binding document that was signed between ServQ and its collaborators before the start of their formal relationship. A questionnaire (Appendix D) was designed to identify issues with the current arrangement. The analysis of the questionnaire was responsible for prioritising of the different issues that hinder

collaboration in ServQ and motivations of ServQ and its collaborators to enter into a collaborative arrangement. The following were the top motivations for collaboration with ServQ according to the responses:-

1. Increased core competency of the Associates through joint development of IP as well as training with ServQ;
2. Increased area coverage geographically and chance to work with Associates in a wide range of industry sectors;
3. Increased monetary as well as business benefits due to higher project availability; and
4. Increased skill set development through training and networking.

An observation of the motivations gives the notion of collaborators being part of this arrangement either for increased business opportunities (transactional) or for better value through increased networking opportunities (relational). However, an issue with the current partnership agreement is a lack of clear communication of these motivations of collaborations within the partnership agreement. The collaborators identified lack of periodic reviews of the partnership agreement as also responsible for the inability of collaborating parties to understand the needs of the other collaborators which might change with respect to time. Lastly, according to ServQ directors, the partnership agreement was never intended to be only a legislative document; hence the document seems unable to fulfil its goal. The analysis of these major issues can be summarised as:-

1. Lack of communication of ServQ's values, mission and goals before entering any agreement;
2. Lack of a joint goal setting between ServQ and new collaborators;
3. Lack of effective communication of reward structure to develop calculation trust;
4. Lack of emphasis on the 'soft' issues of collaboration such as building trust and commitment;
5. Lack of communication of motivations such as building core competencies through training and development of networks to join the collaboration to generate trust based on mutual understanding;
6. Lack of communication of commitment; and
7. Lack of encouragement to share sensitive information within the collaboration while signing confidentiality undertakings for the background and foreground IP generated through collaboration.

#### **4.3.3 ADOPTION OF A NEW COLLABORATION CHARTER**

Based on the literature review on the different aspects of the people factor in collaboration and the issues identified in the existing collaboration agreement, Collaboration Charter (Appendix F) was proposed. It includes the following important sections:

- ServQ values and ethos;
- Vision;
- Communication aspects of collaboration;
- Sustainable relationship development; and
- Legal agreement

The Collaboration Charter was evaluated with Associates to ascertain its usefulness in fostering better collaboration through a strategic workshop. The workshop participants consisted of ServQ directors as well as three prospective collaborators. The workshop

discussed the aims of the Collaboration Charter and enquired if the aims were satisfied by the document. The workshop participants found the charter to be explicit in detail regarding the aims of ServQ’s aims, aspirations and approach towards collaboration. According to the workshop participants, the new Collaboration Charter:

- Emphasised ServQ’s collaboration process protocol and open communication;
- Outlined the formal as well as informal aspects to consider for the development of trust;
- Actively promoted training and development of collaborator’s competencies through regular workshops; and
- Acknowledged the dynamic and time dependent nature of aims and goals that Associates might have within the collaboration with the help of periodic reviews.

Table 4.1 outlines the major differences between the old partnership agreement and the new Collaboration Charter along with the literature to support the changes.

**Table 4.1 - Comparison of old partnership agreement and the proposed collaboration charter**

Old Agreement	Literature support	New Charter
1. No introduction of Firm A, its values, vision and mission.	Importance of communication for building contextual factors of trust (Nguyen <i>et al.</i> , 2008) and commitment (Wu <i>et al.</i> , 2006)	The charter starts with an introduction of Firm A and its vision and mission.
2. Lack of joint goal setting.	Building psychological contract with Associates (Rousseau, 1998)	Importance of joint goal setting at the start of the relationship.
3. Lack of documentation of arranging networking events and development of core competencies.	Commitment towards collaboration (Cullen <i>et al.</i> , 2000; Wu <i>et al.</i> , 2006) and development of trust based on mutual understanding (Nguyen <i>et al.</i> , 2008)	An assurance to arrange regular networking events and training workshops in return for active participation from Associates and help in conducting these events.
4. Lack of reward structure for finding business.	Calculation trust development (Child, 2001) and age related motivations (Segers <i>et al.</i> , 2008)	A detailed reward structure to encourage prospective project finding.
5. Lack of a process to regularly review the agreement as well as collaboration.	Avoiding conflictual situations (Child, 2001)	Annual review of the charter as a requirement to justify collaboration.

#### 4.3.4 FINDINGS OF PEOPLE FACTOR

The summary findings of the People factor are best considered from the point of view of Value. The value of CW was enhanced with the help of the Collaboration Charter in ServQ. The findings underlined a number of critical factors that were needed to be considered such as regular and adequate communications, periodic reviews, identification of individual aims within the collaboration and joint goal setting. The Collaboration Charter was adopted by

ServQ in 2008. According to the observations of the Directors and collaborators of ServQ, the Collaboration Charter provides a vehicle to ensure these ineffective values are changed to effective values by providing a platform to support the CW by:

- Development of trust over a period of time through following small but definite steps charted by an established roadmap that singled out the requirements of all collaborating parties at the start of the relationship.
- The focus of the Collaboration Charter is not internal to ServQ but is external in the shape of ServQ's collaborative environment as the priority i.e. Stakeholder focus.
- A challenge for collaborating SMEs is to balance the need to use the limited resources on implementing existing projects with ensuring the long term survival of the SMEs through winning new work. The Directors felt, the Collaboration Charter enabled them to give more importance to this strategic view with the help of collaborators as compared to the previous partnership agreement.
- Lastly, according to ServQ and its collaborators, signing the Collaboration Charter as compared to previous partnership agreement is a step towards committing to collaboration as compared to compliance.

ServQ and its collaborators are dispersed geographically in UK and outside of UK. Hence, they relied heavily on IT tools to conduct their business and to communicate with each other. For example, they had an extranet to store and retrieve all the required information and they insisted on regular 'Skype' meetings. However, the feedback received from the Associates suggested a discrepancy in terms of conducting important business through such IT means. Hence, there was definitely a gap between the ease of the ServQ Directors and the Associates in terms of IT adoption. The demography of ServQ and its collaborators (please see Paper 2) suggests that, age profile might have been the reason behind the reluctance to use IT tools for collaborating purposes.

#### **4.4 PROCESS FACTOR**

Organisations involved in collaborative working need to understand the different processes involved to ensure smooth collaborative working. ServQ can be described as a project-based organisation. It was difficult to find any formal functional coordination over project lines. However, in view of VECW, it was important to understand how organisational processes play an important role in creating value in the collaborative working relationships. Paper 3 focused on Understanding of the processes and mapping it to create value in CW (Appendix C). ServQ is a small organisation involved in providing a wide range of services and hence requires external collaborators to provide the required competencies in the different areas while keeping the running costs of the organisation low. Such arrangements allow collaborators to pool resources, exploit complementarities and provide quick and flexible access to external resources (Das, 2000; Anand *et al.*, 2000; Hoffmann *et al.*, 2001; Belderbos *et al.*, 2004). Paper 3 (Appendix C) considers such project-based small service firms and develops a process model. The aim of the process modelling exercise was to understand the key mechanisms of the business process to achieve efficiency within the collaborative working environment, essentially increasing the value of the collaborative arrangement.

The research adopted a method of understanding the current flow of processes and models a comprehensive process model to give a strategic focus to the organisational processes. This statement indicates that equal importance need to be given to the strategic, organisational as well as tactical processes of ServQ by fully modelling it and communicating it with the



collaborators. The Process factor relates to the technical (project-based) as well as managerial (organisational and strategic processes) systems required for the smooth working of the collaboration.

The review of literature identified typical process issues related to governance in an organisation like ServQ with collaborative arrangements. Some of these issues identified in literature are:

- The challenge to derive a balance of collaborators' involvement in operational management at the organisational level, as well as, a strategy implementation, resulting in long-term sustainability of collaboration. (Das *et al.*, 2000);
- An unambiguous decision making process in which anticipated results are directly linked to the justification for the decision (expected benefits) and the means to support their delivery (resources) (European Monitoring Centre, 2005);
- A learning approach to strategy management where project results and performance are regularly appraised against the overall strategic goals of the collaborative enterprise (European Monitoring Centre, 2005);
- Clear communication of the strategic priorities as well as the governance mechanism for the collaborative enterprise (Belderbos *et al.*, 2004); and
- To maintain the project-based organisational strengths of coping with emerging situations and responding quickly to changing client needs (European Monitoring Centre, 2005).

#### **4.4.1 RATIONALE BEHIND IDEF0 FOR PROCESS MODELLING**

Business process modelling is considered an established way for organisations to identify and rectify such bottlenecks in their processes (Vergidis *et al.*, 2008). A wide variety of business process modelling techniques is available. The most common diagrammatic techniques for business process-modelling are flowcharts, Interim Data Exchange Format (IDEF), role activity diagrams, data flow diagrams and Petri-nets (Aguilar-Saven, 2004; Bridgeland *et al.*, 2009). The selection of one process modelling technique for ServQ's collaborative working was based on the requirements of the directors of ServQ as well as the collaborators. It was agreed that the process model needed to cover the following based on the viewpoint of process model development:

- A formal model with standard syntax (language rules) for an enterprise (organisation and collaborators) wide consistency;
- Supportive model documentation that would eventually help in determining the audit trails and different record keeping requirements for quality systems like ISO;
- An adoptive model that is responsive to changes;
- An easy to understand, user-friendly model. The model needs to have a degree of flexibility and thus, every possibility is not required to be represented within it; and
- Lastly, it needed to be coherent and complete.

The attributes of IDEF0 matched with the ServQ Directors' requirements and hence, it was the preferred method for business process modelling. Paper 3 (Appendix C) also presents the advantages of IDEF0 over other process modelling techniques.

#### 4.4.2 A BUSINESS PROCESS MODEL

The IDEF0 model for ServQ's collaborative working was developed from the viewpoint of 'Manage ServQ's collaboration'. The business model was proposed with the aim of providing an overview of all the important activities to effectively manage the strategic and operational management activities of ServQ. The model developed was decomposed into three levels starting with the context diagram, followed by parent diagram and child diagrams. These levels are:

- Node CW: This was the context diagram and provided a general view of the management of collaboration in ServQ as a small service organisation;
- Node A0: This diagram represented the parent diagram of ServQ's process of collaborative working. The identification of the main processes for the parent diagram consisted of identifying the major processes of managing the firm and then grouping them in three to six headings to form the main processes.
- Node A3: This diagram represented a specific process of establishing the core associate team.

Figure 4.3 shows one of the nodes to illustrate the process of acquiring the different tools and techniques required by ServQ. Other IDEF0 diagrams are included in Appendix G.

#### 4.4.3 EXAMPLE NODE – NODE A2

Figure 4.3 is an example of one of the nodes developed in IDEF0 for ServQ and its collaborators. After the initial case study, it was identified that communication of the core capabilities of ServQ and its collaborators was not clear even amongst the stakeholders. Hence, the issue was to identify a way to communicate, not only the core capabilities by the identification of current tools and technology, but also putting in place a process model to guide the Directors of ServQ and its collaborators to acquire new tools and technology in a systematic manner.

The process of acquiring starts with the search of the tools and techniques that are useful to carry out the core services of ServQ based on the perceived market gap by the Directors. However, not all the tools would be available to ServQ or some may prove too expensive to acquire. If the areas covered by such management tools are important then ServQ will need to develop alternative tools or processes.

These different tools may not share a similar platform as they are often developed by different organisations for diverse industry sectors and on different platforms. Hence, synergies between these tools and techniques help justify ServQ's capabilities in targeted core services. The intellectual property rights and finances available for acquiring or developing the tools would be the two constant controls over each of the sub-processes. In addition, the prevailing market conditions will also affect the licensing, buying or development of management tools and techniques.

The owners of the licensed products are expected to involve themselves in the implementation of their products within the core services provided by ServQ. An example of that would be making a presentation for proprietary product in lieu of ServQ for major client projects. They would be involved in the Strategic Partners' capability, to be a direct mechanism to improve their tools and techniques through feedback and further refining. Hence, strategic partners along with Directors are important mechanisms in the sub-

processes. The major outputs of these sub-processes would be a portfolio of tools and techniques and an awareness of the training requirements to use them effectively.

The Node A2 - IDEF0 diagram with the brief explanation provides an example of the clear dissemination of process ownership in the collaborative working environment of ServQ. It provides information about the different stakeholders and their possible involvement at each of the stages and the constraints that they need to work around, along with the inputs available and the outputs expected.

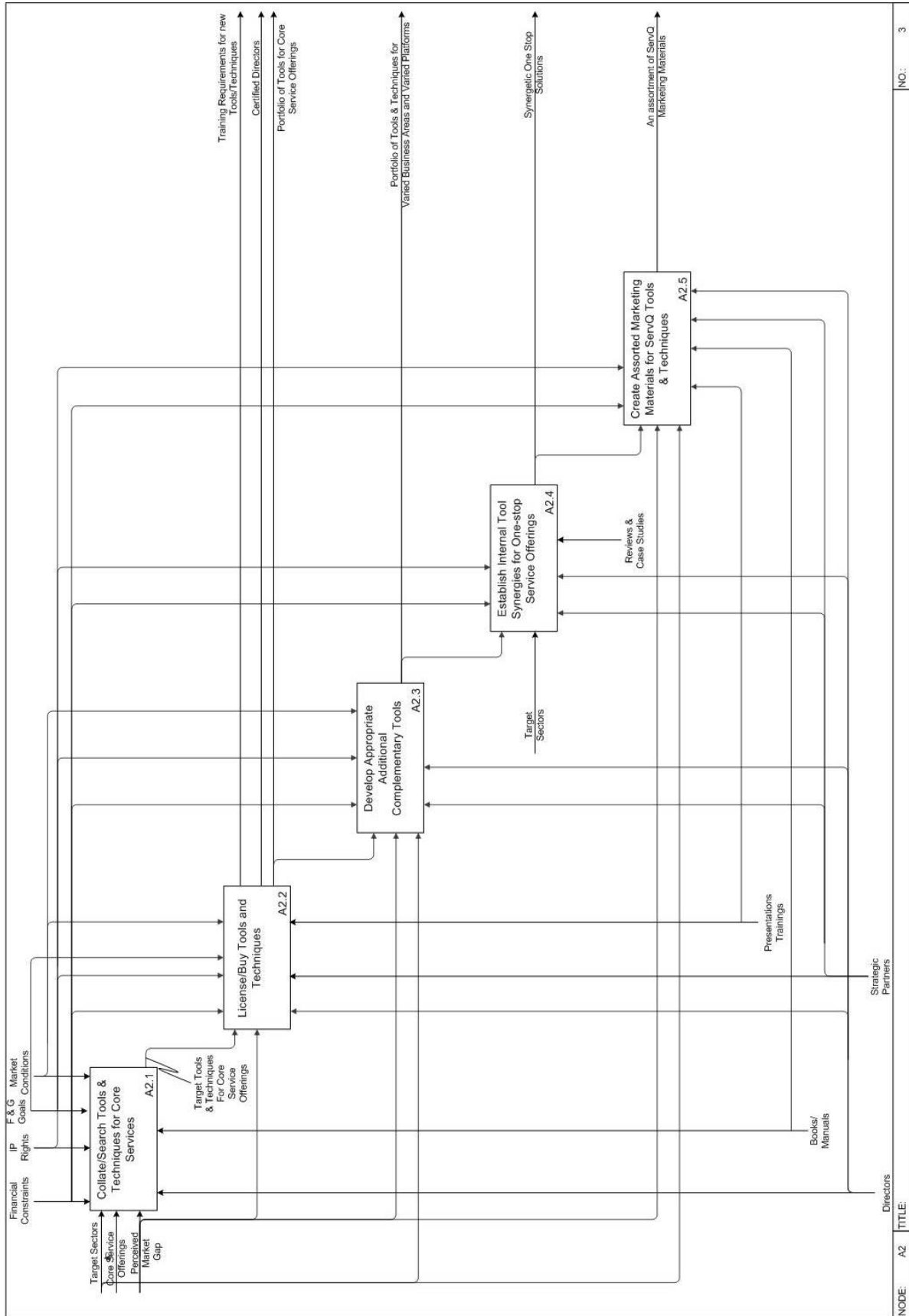

Figure 4.3 – Node A2 of ServQ’s process model

#### **4.4.4 EFFECTS OF CHANGES MODELLED IN IDEF0**

An evaluation of the process model against the issues identified in Section 4.4 was carried out. The evaluators felt the exercise assisted in control and compliance within the collaboration directly resulting in clear decision-making processes. The process model isolated the project related work in nodes A5 and A6 while nodes A1, A2 and A3 primarily dealt with the strategy planning and implementation. Appendix G provides the IDEF0 diagrams for all the nodes developed for ServQ. In addition, the following benefits were identified by the Directors and collaborators of ServQ.

- Communication of information requirements at each process stage –The use of this process model communicates the delivery requirements at each stage for the different parties involved. Hence, it makes clear the role of the different collaborators of ServQ.
- Generating service value – The processes creates more value when every collaborator involved knows why a certain process is required and the value of the output of that process. For example, involving collaborators in strategic decision making on tools training will ensure the value of getting the required training for better prospects of particular work in future. It helps to remove the non-value adding processes that might be noticed over a period of time due to continuous usage of the developed process model.
- Enabling an auditable trail – A standard practice (generated by the process model) is useful in providing an auditable trail for the organisation intending to get accreditation from organisations like ISO (International Standards Organisation).
- Better work planning for collaborators – The collaborators of ServQ are independent businesses or self-employed consultants. They appreciated a standardised process as it helps them to better organise their daily diaries.
- Information management – The proposed process model is helpful in generating accurate information that can be used for marketing purposes, for providing information to clients and for managing information internally.

#### **4.4.5 FINDINGS OF PROCESS FACTOR**

The direct effects of the IDEF0 process model according to the evaluators were noted in the previous section. Now comparing these benefits with the original issues identified in section 4.4, it is clear that:

- IDEF0 clearly indicates process ownership at operational, organisational and strategic levels leading to a balanced involvement of collaborators at each level. This situation helps in long-term sustainability of collaboration since it communicates and gives a chance to all concerned parties to get involved in CW.
- The decision making process for any activity or process in ServQ's collaborative working environment is clearly demonstrated in the process maps and hence, there is an unambiguous decision making process in place for everyone involved to follow.
- A learning approach to strategy management where project results and performance are regularly appraised against the overall strategic goals of the collaborative enterprise (PBSO and its collaborators); and
- Ensuring the project-based organisational strengths while helping the strategic management of the organisation with help of collaborators.

The phenomenon above indicated that the Process factor is an essential part of VECW. The Process factor is important for changing the traditional disjointed strategic management and governance of firms like ServQ with the help of business process modelling using tools like IDEF0.

## **4.5 TOOLS FACTOR**

ServQ's portfolio of tools are licensed or developed based on their philosophy to provide services in the areas of strategy formulation, organisational alignment, partnering and alliancing and implementation of projects (Appendix D)

Tools play an important role in ServQ's collaborative working. ServQ has a portfolio of tools either developed by themselves or licensed to help them carry out their consulting assignments. These tools in isolation or in conjunction with other tools are used for meeting the needs of the client organisations by ServQ and their Associates.

An issue with the wide variety of tools and techniques available with ServQ is the evident dissimilarity within these tools in terms of the representation platform and an apparent lack of synergy between them. The tools and techniques licensed and developed by ServQ were originally developed for different industries. Hence, they do not follow a set of similar procedures. They even do not have similar user interfaces. Subsequently, ServQ has tools that are either questionnaire based or numerical models, that can be conducted either by use of workshops or represented by graphical and diagrammatical representations. The result of this wide variety of tools is that clients find it hard to understand when ServQ wants to use a combination of tools to satisfy the client's needs. Furthermore, Associates new to the collaboration with ServQ and with experience in a specific industry, find it difficult to understand the synergy between the wide arrays of tools.

### **4.5.1 INVESTIGATION OF SYNERGY NEEDS BETWEEN TOOLS**

The concept of synergy essentially considers that value can be created by generating interrelationships across two different set of objects/tools/people, etc (Osegowitsch, 2001). Normally, the concept of synergy is discussed between different industries or different organisations, but in the current context it is the synergy between the different tools that ServQ possess in its portfolio. ServQ has potentially complex tools and techniques available with differences as well as similarities amongst each other. The value of establishing synergies between the different tools available with the organisation can be immense since it provides a one-stop solution to a wide variety of issues over diverse industries. An internal report on how to establish synergy between the ServQ tools was developed (Appendix H).

ServQ had previously managed to share tangible as well intangible resources of these tools to derive benefits. The tangible resources can be the reports generated for a particular tool while intangible benefits consist of the tacit knowledge of the different tools and its advantages. Hence, ServQ considers the notion of synergy as an opportunity within its tools portfolio. The implementation of the synergetic opportunities would require an evaluation of the different factors involved in diverse projects as well as compromise costs. ServQ service teams' (Directors as well as Associates) core competence abilities may suffer as they need to train themselves in all the tools available within ServQ portfolio and that leads to compromise costs.

ServQ's goal was initially the challenge of integration of tools to provide a one-stop solution. However, it has been proven too difficult. Every tool available with ServQ has distinct





























advantages. ServQ's project aims are achieved by part or full use of a combination of such tools. The creation of synergy or integration of tools available with ServQ could be foreseen in three ways. The first was considering the tools available with ServQ as 'a bag or tricks' where one tool was used after another to achieve the project aim. The second way was to consider it as a multiplicative model where parts of the tools together were used to achieve the project aim while the third way was to get a diagnostic tool used first to identify specific issues that could be solved with subsequent use of other specific tools. Scenario Planning could be used to describe how such synergy between tools can be translated into projects for ServQ.

Scenario generation is an important research tool if utilised in an appropriate condition. Chapter 3 on Research Method gave a short introduction to the synergy generation exercise along with a method statement for the research. In the ServQ context, the scenario planning exercise can be an anticipation exercise to find out the gaps in the current tools against the needs of a specific project. The exercise is also useful to develop strategy for potential target industries by exploring the stages at which ServQ can get involved and the type of tools that can be used. Hence, the following were the aims of generating scenarios in the ServQ context:

1. To ascertain synergy between the different tools available within the ServQ portfolio.
2. To examine the value of different types of tools available within the ServQ portfolio.
3. To breakdown the projects into process stages that can be equated to the individual processes of particular tools.
4. Identify different approaches for implementing the same projects. The scenarios need to be generated with a balance of surprise situations and plausible situations, since there needs to be a trade-off between surprise and plausibility (Hirschhom, 1980).

The client industry for the scenario generation was chosen as the construction industry. Before generating the scenarios, it was important to generate the key internal factors and external forces of scenario building in the construction industry. Table 4.2 describes the key internal ServQ factors and external driving forces for scenario building. The factors and forces are based on the description of internal key factors and external forces that might either be uncertain and/or have an impact on the scenarios being built. The factors and forces are colour coded according to the probability and the potential impact with respect to the construction industry. The internal factors and external forces with highest probability and most impacts are coloured green, medium one with orange and least probability and impact with red. The green factors are considered important for scenario generation.

**Table 4.2 - Internal factors and external forces of scenario building for construction industry clients (based on Hirschhom, 1980)**

No.	Identify Key Internal Factors	Traffic Light Coding	
		Probability	Potential Impact
1	Origin industry for the tools (and its comparison to the end user industry)		
2	Classification (Legacy tools vs. general techniques) establishes training requirements		
3	Type of representation in the tool or technique (questionnaire based, numerical model, diagrammatic, workshops combination, etc.)		
4	Availability of internally trained people for conducting the use of tools		
<b>External Forces</b>			
1	The original client (client who assigns the consultation)		
2	Stage wise process mapping of the target industry		
3	Types and number of stakeholders involved		
4	Industry orthodoxy in terms of embracing new tools and techniques		
5	Project time constraints		
6	Consultation budget		
7	Up-front definition of client needs (one off opportunity or multiple ongoing)		
8	Proactive or reactive		
9	General market conditions (Buoyancy)		
10	Types of contracts considered		

From the above table it is clear that availability of internally trained people for conducting the use of tools is the least probable internal factor while the probability increases when a tool developed for a particular industry was used for another industry. The probability was also highly dependent on the training requirements based on being a legacy tool as compared to a general technique. In terms of potential impact internally trained people was deemed most important.

When considering the external forces, the probability related to types of contracts used as well as client requirements did not possess much probability. However, in terms of potential impact, project time constraints, consultation budgets of the client and traditional views of the client industry were most important.

#### 4.5.2 SELECTIONS OF PROJECTS AND SCENARIOS

The selection of the projects and scenarios were based on the following characteristics: ServQ had prepared tenders for both the projects discussed here.



1. Project 1's client was a construction and building materials manufacturer while Project 2's client was a construction of water utilities and services provider in water utilities.
2. The requirements of both the projects were different from each other. While Project 1 wanted development in internal performance improvements, Project 2 wanted facilitation for alliance development. Project 1 was directly related to the internal process structure of the project while project 2 was a means of facilitation to conduct seamless collaboration.
3. Both were projects in a large construction organisation, similar to the size of target ServQ client organisations.
4. Project 1 was a time-bound one-off opportunity whilst Project 2 was looking to find a facilitation partner to work initially for a set period with a possibility of extension.
5. There were differences between the driving forces of both these projects. Project 1 was reactive with respect to the sales performances, while Project 2 was proactive with respect to development of a new alliance before the next framework agreement was signed.
6. Two scenarios were considered for each of the projects to show how tools can be used in various combinations based on the client requirements.

The result of the scenarios developed were two different ways of conducting the same projects. Each scenario for the same project used different tools available with ServQ thus providing ServQ with multiple options. Appendix H describes both the project briefs along with the scenario development and the results of the scenario planning exercise. Whilst ServQ agreed with both the scenarios as possible solutions for the two examples of prospective projects, the individual factors (such as availability of people with required training and budget) of the prospective projects would decide the best scenario for a particular project. However, for the tools factor it was important to realise the process of finding and establishing synergies between the different tools available with ServQ rather than the actual results of the scenarios.

### **4.5.3 FINDINGS OF TOOLS FACTOR**

The findings of the scenario generation exercise concluded the following observations:

- Some synergies were easily realised, if there were many similar or parallel activities among tools while some other synergies might require considerable creativity.
- The exploitation of the synergies between different tools had wide obstructions ranging from different IT platforms to apparent incompatible organisational structures.
- Part use of legacy tools required consideration of the Intellectual Property Rights.
- Organisations needed to consider any notional synergies against the associated managerial overheads (trainings for all tools, etc.).
- The value of the scenario planning was in understanding the decision making process of using particular tools for particular projects.

The research findings indicated that the tools factor is important to consider for enhancing value in a collaborating working environment where there is a reliance on collaborative tools. However synergies between the different types of tools available with ServQ need to be realised by all the stakeholders. In addition, it is realised that such synergies are hard to realise due to the different backgrounds of the tools as well as the different platforms of their basis. Lastly, there is importance of considering synergy benefits against the associated

managerial overheads as it is hard to justify if the potential synergy benefits far outweigh the managerial overhead costs.

## 5 EVALUATION

### 5.1 OVERVIEW

This chapter presents the findings of evaluations that were conducted to capture user perspectives on the ability of the VECW framework to achieve its aim. Feedback from evaluators was analysed both qualitatively and quantitatively. Figure 5.1 illustrates the evaluation process.

Evaluation is a systematic process that involves collecting and reviewing data regarding issues about society in general and organisations and programs in particular (Morris *et al.*, 1987; Preskill *et al.*, 1999; Rossi *et al.*, 2004). According to Futrell *et al.* (2002), evaluation consists of jointly reviewing a system or product with end-users in order to learn about necessary changes required to meet user expectations.

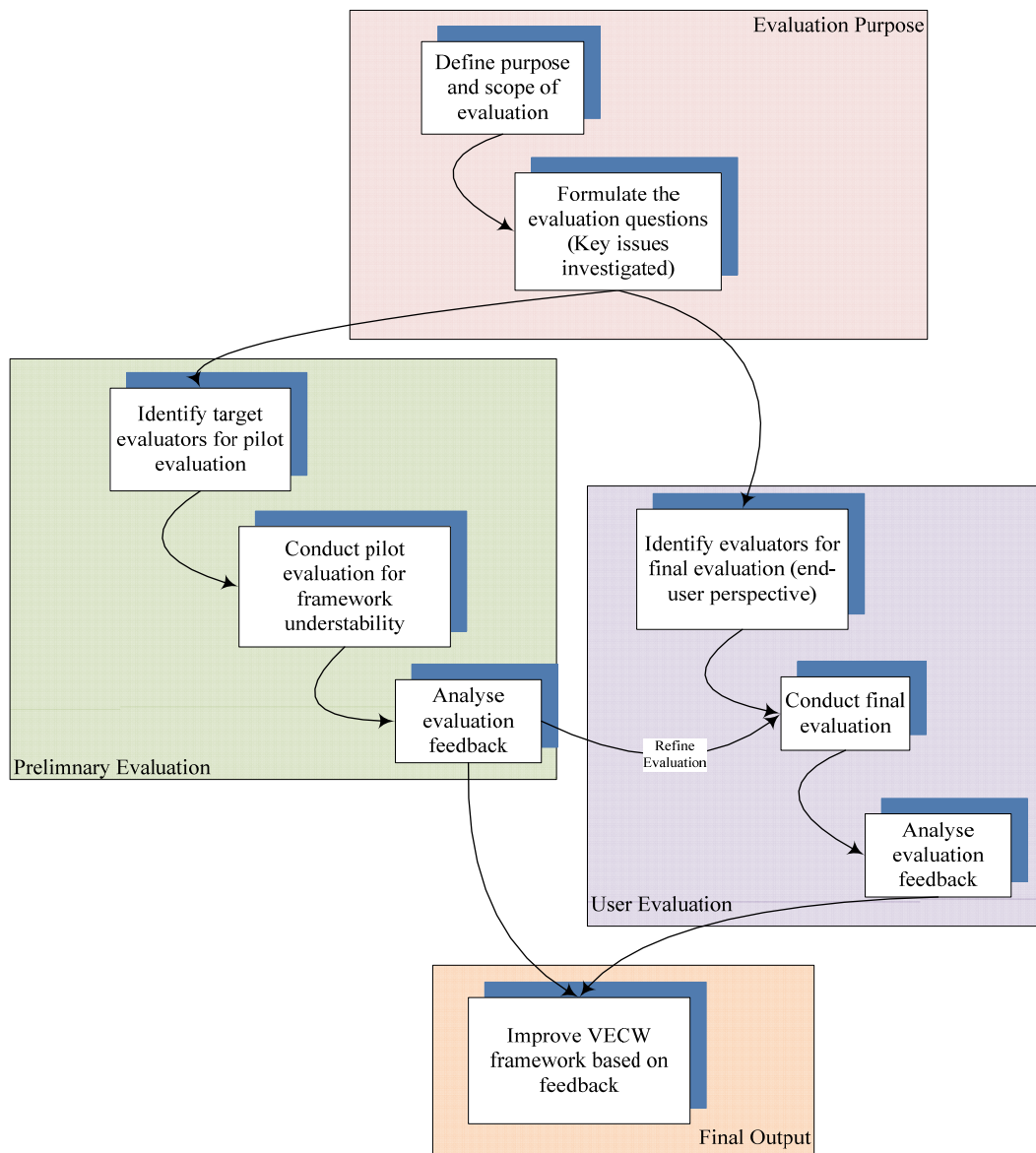

Figure 5.1 – Evaluation Process

## 5.2 EVALUATION PROCESS

The evaluation process can be explained by dividing it into evaluation purpose, development of evaluation questionnaire and conducting the preliminary and user evaluation.

### 5.2.1 EVALUATION PURPOSE

The first step of evaluation was to define its purpose and scope. Definition of the purpose led to the identification of objectives of the evaluation. At this stage the potential evaluators were also identified. Table 5.1 lists the different types of evaluation along with a brief description of each.

**Table 5.1 - Types of Evaluation (Based on Preskill *et al.*, 1999)**

Types of Evaluation	Description
Developmental Evaluation	Helps to position the evaluator as part of a system's design and developmental process.
Formative Evaluation	Typically conducted for the purpose of refining or improving a system and is often conducted by internal evaluators.
Summative Evaluation	Implemented primarily for the purpose of determining the value of the evaluands in a way that leads to final judgement. It is generally for the benefit for the external audiences as well as decision makers.
Outcome Evaluation	Seeks to understand the intended changes in knowledge, attitudes and practices due to a system intervention.
Impact Evaluation	Focuses on the impact on participants because of the intervention.

The purpose of evaluation for the current work was to assess if the developed VECW framework actually met the industry's needs. Hence the evaluators were individuals who were involved in collaborative working with ServQ. In addition, a targeted group of researchers in related fields of collaboration also evaluated the framework. The objective of the evaluators was to conduct a formative evaluation as defined in Table 5.1. However, the involvement of the targeted group of researchers in the evaluation also ensured that the final judgement on the system was carried out through a summative evaluation. The objectives of the evaluation process were as follows:

- To verify if the VECW framework satisfies the research objectives;
- To evaluate the usability, ease of use, understandability and acceptability of the VECW framework;
- To obtain feedback to further improve the VECW framework; and
- To capture end-user perspectives on industrial barriers and facilitators to guide future development.

### 5.2.2 EVALUATION QUESTIONNAIRE

The above mentioned objectives determined the development of the evaluation questionnaire. Since the developed framework consisted of three distinct factors of collaborative working i.e. People, Processes and Tools, questions were divided into three sections for each factor and finally the overall framework. The questions consisted of the mechanisms generated in order to solve the specific collaboration issues in each factors. A Likert scale was used as it gave a way to express summated ratings to the evaluation responses and consisted of specific questions related to the usability of each of the mechanisms (for example, Collaboration Charter, Scenario Planning exercises and IDEF0 Business Process Mapping) and acceptability as a mechanism within the VECW framework. Lastly, open questions at the end of the questionnaire helped in determining the end-users' perspectives on the use of the framework, its advantages and barriers, and how to improve the framework further. The evaluation questionnaire is shown in Appendix I.

### 5.3 EVALUATION PROCESS DESIGN

The evaluation process consisted of the following steps:

- Two sets of evaluations were conducted – A preliminary evaluation and a user-centric evaluation.
- A presentation on the research background including ServQ's background and issues of CW in ServQ were given to both set of evaluators. A presentation also discussed the different mechanisms to help resolve the identified issues.
- The VECW framework was explained along with guidelines for ServQ to follow, and advantages as well as limitations of the work.
- A focus group discussion was conducted among evaluators in order to elicit possible improvements and to determine implementation issues for the framework.
- Finally, evaluators were requested to complete a questionnaire addressing the previously identified issues to give structured feedback and understand the end-user perception of the framework.

#### 5.3.1 PRELIMINARY EVALUATIONS

At the preliminary evaluation stage the VECW framework was evaluated for its ease of understanding. An unsolicited mail was sent out to the researchers in the department of Civil and Building Engineering at Loughborough University inviting them to participate in an evaluation workshop. In total six researchers attended the evaluation workshop. The evaluators were selected based on their previous experience of working in research areas of Collaborative Working, Value or Concurrent Engineering which are key components of the developed framework.

At the workshop the evaluators were given an overview of the framework and the purpose of evaluation explained. The workshop initially explained the issues faced by ServQ regarding collaboration based on the findings of Paper 1 (see Appendix A). The workshop presentation further explained how People, Process and Tools factors were each individually considered through different mechanisms as discussed in Chapter 4 and Papers 2 and 3 (see Appendices B and C). Each evaluator completed a questionnaire (see Appendix I) and feedback received from this preliminary evaluation was used to improve the framework.

The preliminary evaluators felt that the presentation was detailed enough to give an idea about the different aspects of VECW and how the VECW framework was conceptualised.

However, a major point of discussion among the participants was if there should be a discussion on the relative importance of People, Process and Tools factors. Eventually, the participants agreed that it is highly dependent on a case to case basis and since the current work was subject of only one SME, it was not required to be discussed more. Hence, it was noted as a point to consider for adoption of VECW in other organisations, industries or sectors before adopting. Lastly, the VECW guidelines presented in the preliminary presentation were advised to be further developed in terms of the timelines associated with each point. This was carried out before carrying out final evaluations.

### **5.3.2 USER EVALUATIONS**

Following the preliminary evaluation, changes were made to the presentation to further refine the evaluation process. The end-user evaluation was conducted with ServQ Directors and current and prospective Associates of ServQ. Since the Directors were involved with the research from the start, a conscious decision was made to include Associates who had not been previously engaged with any aspects of the research. The focus group consisted of five participants and the focus group facilitator (i.e. researcher). Since, the focus group consisted of participants not previously involved in the research, it was considered adequate for the researcher to act as the focus group facilitator. The process of evaluation was similar to that of preliminary evaluation to ensure comparison between both groups of evaluands.

## **5.4 FINDINGS OF THE EVALUATION**

This section will provide the interpretation of the findings based on the evaluation. It also discusses any limitations or weaknesses in the findings and comments on the generalisability of the findings. Lastly, it will try to point out any unexpected findings.

### **5.4.1 EVALUATOR PURPOSE**

In order to determine whether a significant difference in opinion exists between preliminary evaluators and end-user perspective, a combination of analytical techniques was used on the responses of the two groups. These included comparison of means, medians and mean distribution.

According to Kvanli *et al.* (2000), Mean (the average of a given set of data) and Median (the central value of a given set of data) are the most popular measures to find central tendency. As compared to Mean, a Median would provide a more reliable measure of central tendency if there are significant high or low values as compared to other average values. Table 5.2 provides a composite table of the mean, median and standard deviation for both preliminary and end-user evaluators.

**Table 5.2 – Evaluation of Mean, Median and Standard Deviation for responses of Preliminary as well as End User Evaluation**

Ref. No.	Factor		Preliminary Evaluation			End User Evaluation		
			Mean	Median	Std.Dev.	Mean	Median	Std.Dev.
		Understanding the importance of Collaboration						
A.1	People	Charter	4.33	4.5	0.82	5.00	5.0	0.00
A.2		Importance of common vision	4.00	4.0	0.63	4.40	4.0	0.55
A.3		Clear communication channels between people	4.00	4.0	0.63	4.20	4.0	0.45
A.4		Creation of CW environment	4.50	4.5	0.52	4.40	5.0	0.89
A.5		Assistance in professional development	4.17	4.0	0.75	3.60	4.0	0.89
A.6		Encouraging stakeholder trust & commitment	3.83	4.0	0.75	4.40	4.0	0.55
A.7		Sustain long term CW	4.33	4.0	0.52	4.40	5.0	0.89
A.8		Periodic review change collaboration as required	4.67	5.0	0.82	4.60	5.0	0.55
A.9		Shortening of service delivery time	4.17	4.0	0.75	3.60	4.0	1.14
B.1	Process	Consensus building helpful in CW	4.33	5.0	1.03	4.80	5.0	0.45
B.2		Provides flexibility with required detail	4.50	4.5	0.55	4.40	5.0	0.89
B.3		Ensures value of stakeholder participation	4.50	4.5	0.55	5.00	5.0	0.00
B.4		Enables ownership of processes	4.00	4.0	0.63	4.20	4.0	0.45
B.5		Identifies resource requirements of each process	4.17	4.0	0.41	3.40	4.0	1.52
B.6		New stakeholder induction	4.00	4.0	0.63	4.20	4.0	0.45
B.7		Helps to delineate motivation among stakeholders	3.67	3.5	0.82	3.80	4.0	0.45
B.8		Shortening of service delivery time	4.00	4.0	0.89	4.00	4.0	0.71
B.9		Standardised approach balanced with flexibility	4.00	4.0	0.63	4.20	4.0	0.84
B.10		Identification of specific training requirements	4.50	4.5	0.55	4.00	4.0	1.22
C.1	Tools	Scenario planning provides insight of different tools	4.33	4.0	0.52	4.20	4.0	0.45

## Value Enhanced Collaborative Working (VECW)

---

C.2		Identification of synergies between tools	4.17	4.0	0.75	4.60	5.0	0.55
C.3		Gap analysis of tools available	4.50	5.0	0.84	4.40	4.0	0.55
C.4		Commit support for additional tools	4.50	4.5	0.55	4.00	4.0	0.71
C.5		Scenario planning exercise source of business cases	3.33	3.0	1.03	4.40	5.0	0.89
C.6		Stakeholders given milestone engagement targets	4.00	4.0	0.00	4.60	5.0	0.55
C.7		Individual understanding of tools' core competencies	4.33	4.5	0.82	4.20	4.0	0.45
C.8		Identification and generation of new IP	4.50	5.0	0.63	3.80	4.0	0.84
C.9		Identification of specific training requirements	4.50	4.5	0.55	4.00	4.0	0.71
C.10		Resource management in terms of core competency & availability	4.17	4.0	0.41	4.20	4.0	0.84
D.1	Overall	Purposeful overall strategy for CW	4.33	4.5	0.82	4.40	4.0	0.55
D.2		Overall understanding of VECW	4.50	4.5	0.55	3.80	4.0	1.10

---



From Table 5.2 it is clear that, in terms of the People factor, preliminary evaluators of the framework mostly agree on ‘Understanding the importance of Collaboration Charter’ and ‘The importance of a common vision’ with a mean of 4.33 and 4.00 respectively. Similarly, means in the user evaluation for the same questions were 5.00 and 4.40. Hence, it indicates the very high agreement on the importance to adopt a collaboration charter with a shared vision between the stakeholders. The importance of a common vision is previously noted in research such as Daugherty *et al.* (2006) and Liu *et al.* (2007). A similar trend was observed among the preliminary evaluators and the end-users of the framework when asked if the framework provides ‘Clear communication channels’ and reflects ‘A collaborative environment to feel comfortable to work in’. The mean for these questions range between 4.00 and 4.50 for both preliminary evaluators and end-users. Hence, it concludes the Collaboration Charter mechanism could help the People factor of VECW framework by providing a clear and common vision, unambiguous communication channels and a better working environment. This is in accordance to the seminal research work in Organisational Development by Grievies (2000) and is an important part of the Critical Success Factors for collaborative working identified by Koutsikouri (2009).

However, when asked about VECW ‘Setting out professional development assistance for stakeholders’, the mean of the responses was only 3.60 with a standard deviation of 0.89 from the end-user evaluators in comparison to 4.17 mean from preliminary evaluators. The disagreement was due to the lack of a roadmap of professional development within the Collaboration Charter. In comparison, there was an overwhelming majority of preliminary evaluators and end-users who agreed on the ‘Development of trust and commitment’ with the help of Collaboration Charter with the responses mean of 3.83 and 4.40. Burt (1997), Hosmer (1995) and Rousseau *et al.* (1998) in their research considered trust and commitment as the major aspects of relationship capital thus agreeing with evaluator sentiments.

Lastly, when asked about VECW framework’s assistance in ensuring ‘Long term sustainable collaboration’, ‘The inbuilt periodic review process’ and the ‘Shortening of the project delivery time’, the mean values of the preliminary and end-users were generally high to suggest sustainable collaboration and periodic review process. Although end-users pointed out the need for more evidence on the shortening of the project delivery time. Hence, overall there was a very high level of agreement on all parameters for the Collaboration Charter mechanism that was developed to solve the People-related issues of VECW as evident from the pie-charts in Figures 5.2 and 5.3.

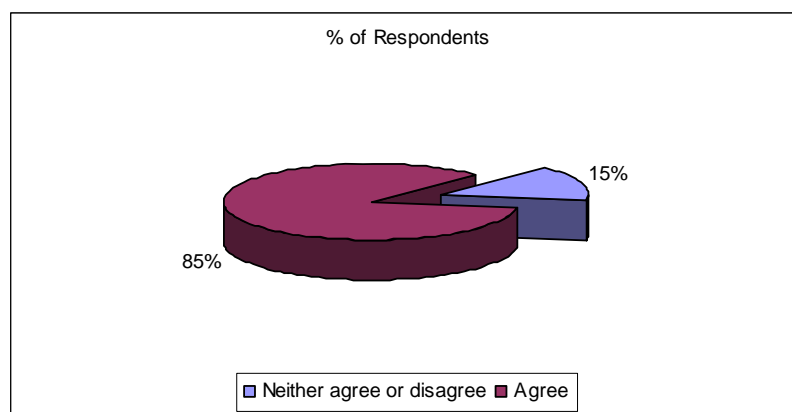

**Figure 5.2 – People Factor Mechanism Evaluation Responses (Preliminary)**

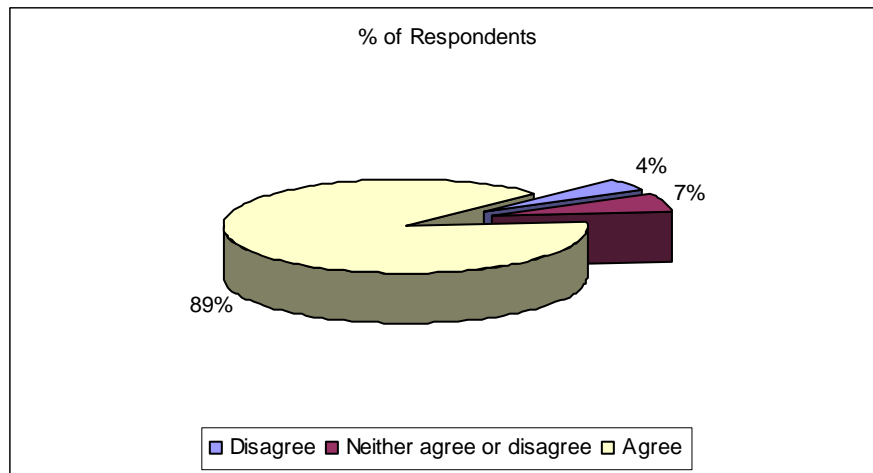

**Figure 5.3 – People Factor Mechanism Evaluation Responses (End User)**

In terms of the development of a Process model mechanism, it was observed from that the mean values that the preliminary evaluators provided an indifferent response to the ‘Consensus building exercise in terms of organisational processes’. The mean value of 4.33 with a standard deviation of 1.03 suggests that some of the preliminary evaluators were not sure of the use of process model as a consensus building exercise, even when Sandhu *et al.* (2004) explained a model of process development for project-based industry. However, in comparison, there was total agreement from the end-users as evidenced in Table 5.5. This change can be attributed to the experience of the end-users in working within similar working arrangements and finding process models useful for getting consensus in decision-making. Similarly, a very high mean value of 4.50 and 4.40 by preliminary and end-user evaluators respectively was achieved for ‘Detail within the process model’. There was total agreement from both preliminary and end-users regarding the ‘Value of stakeholder participation in process model development’ and a high agreement on the ‘Ownership of processes’ achieved with the help of the process model (mean values of 4.0 and 4.2 by preliminary and end-users). This result is significant and in accordance to the previous research works (Gustafsson *et al.*, 2006; Maleyeff, 2006; Huq, 2005; Das *et al.*, 2000).

The response of the end-users was diverse in terms of ‘The identification of resource requirements through process model’ with a standard deviation of 1.54. The high standard deviation is because the mean of the end-user responses was 3.40 with one respondent totally disagreeing. The end-users did not agree if the process model by itself would cover the resource requirements, especially in terms of the external constraints. Interestingly, as evident from Table 5.2 most evaluators (both preliminary and end-users) endorsed the view that ‘New stakeholders can be easily inducted’ in the CW environment with the help of the process model and ‘The process model ascertains required degree of flexibility while keeping a standardised approach’.

In contrast, there was some doubt on the ability of the process model ‘To delineate stakeholder motivations’ among the preliminary evaluators with a mean of 3.67. An apparent explanation could be that a new stakeholder might not make his/her motivations clear, to help the process model to identify it and hence lead to different expectations between the collaborating parties eventually possible failure of long-term collaboration.

Finally, when the evaluators were asked their opinion on the impact of process model in ‘Shortening the service delivery time’ and ‘Identifying the specific training requirements of tools’, the responses had a good mean range between 4.00 and 4.50 in both preliminary and user evaluators. However, the standard deviation of user evaluator responses was 1.22 due to the disagreement of one of the end-user evaluators on the process model’s ability to identify specific training requirements. The end-user argued the view that there would be advantages on both counts but would need to be reviewed over a certain period of time. In summary, the end-users felt that the process model is a mechanism best used in conjunction with other mechanisms as seen from the relatively high level of preliminary respondents neither agreeing or disagreeing whilst a small percentage of end-user evaluators disagreeing as shown in Figures 5.4 and 5.5.

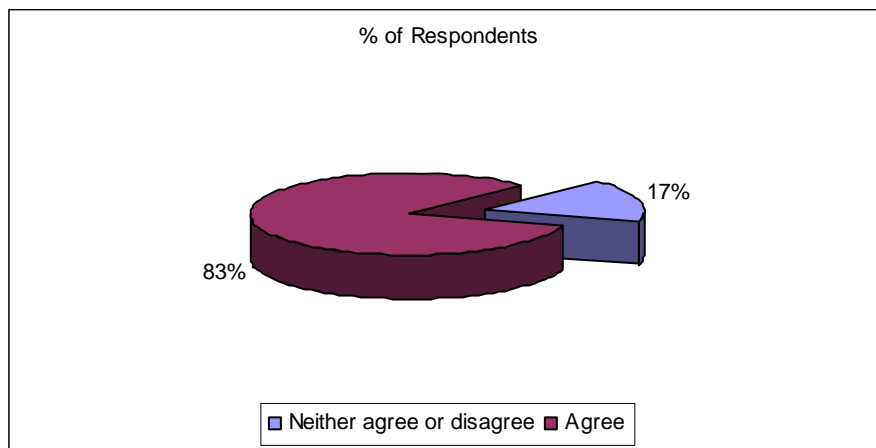

**Figure 5.4 – Process Factor Mechanism Evaluation Responses (Preliminary)**

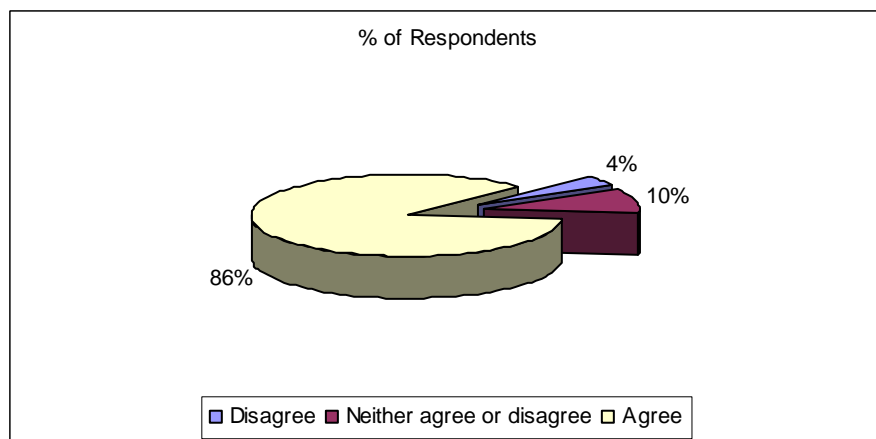

**Figure 5.5 – Process Factor Mechanism Evaluation Responses (End User)**

In addition, the evaluators were asked about the use of Scenario Planning for the Tools factor. When both sets of evaluators were asked about the use of ‘*Scenario Planning exercise providing insight in different types of tools*’, all the respondents agreed on its effectiveness with a 4.33 and 4.20 mean value for preliminary and user evaluations respectively. Responses were also invited on the ability of scenario planning to ‘*Identify synergies between the different tools*’ as well as ‘*Carry gap analysis of the tools*’, the end users were in total

agreement with mean values of 4.20 and 4.6 while, the preliminary evaluators also had a high level of agreement. Hence, it can be inferred that the exercise would prove very useful in terms of synergy identification as well as gap analysis among the tools.

A high level of agreement (preliminary and end-user mean value of 4.50 and 4.40) was also achieved among both sets of evaluators with regard to ‘*Committing support for additional tools requirement*’ however for ‘*Using it as a source of business cases for explicit knowledge*’ the mean response was only 3.33 with 1.03 standard deviation since one of the evaluators disagreed. Hence, there are some questions regarding the scenario planning exercise used as a business case to identify prospective project requirements. Additionally, when the evaluators were asked about the possibility of giving ‘*Milestones in terms of engagement targets*’ based on the Tools factor and asked about the ‘*Collaboration’s core competencies*’, the replies from both sets of evaluators were between mean values of 4.00 and 4.60. However, the end-users felt that the scenario planning exercise in itself would not be critical factor to ‘*Identify and generate new IP*’ for the collaboration with a 3.80 mean value. Lastly, in terms of the ‘*Individual stakeholder training requirements*’ and ‘*Resource management*’, the replies suggested that although the exercise would be an asset, additional supporting work would be required. Figures 5.6 and 5.7 illustrate the percentage of respondents in agreement with the Tools factor mechanism.

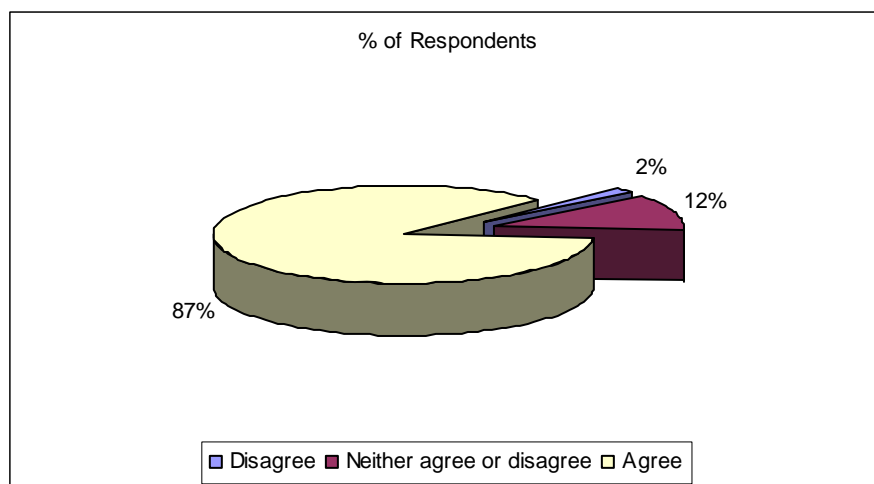

Figure 5.6 – Tools Factor Mechanism Evaluation Responses (Preliminary)

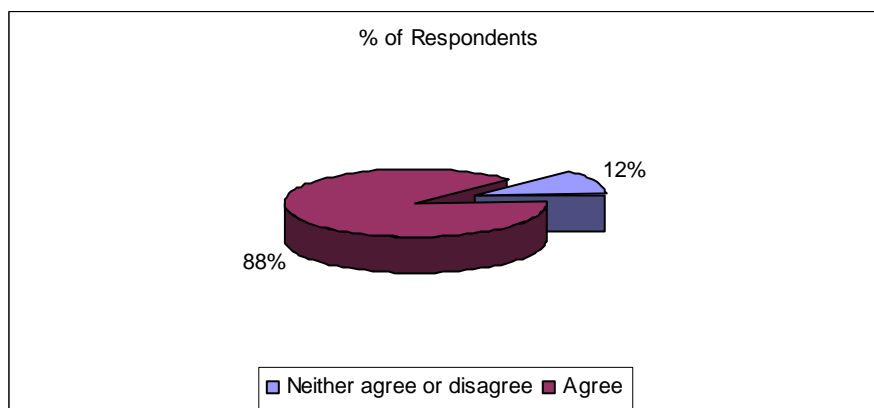
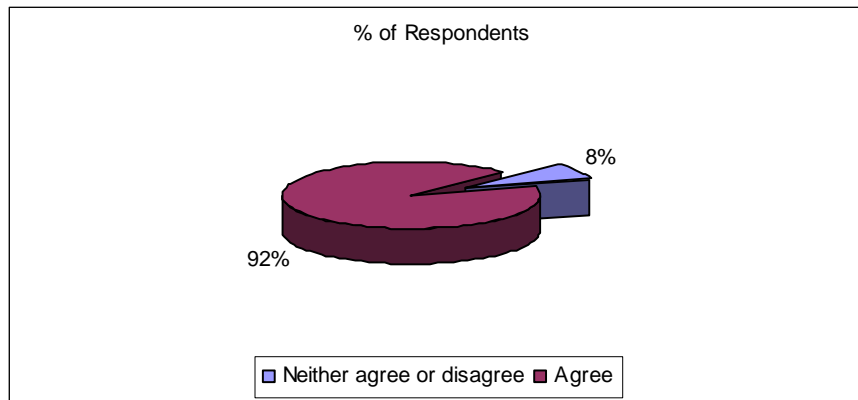
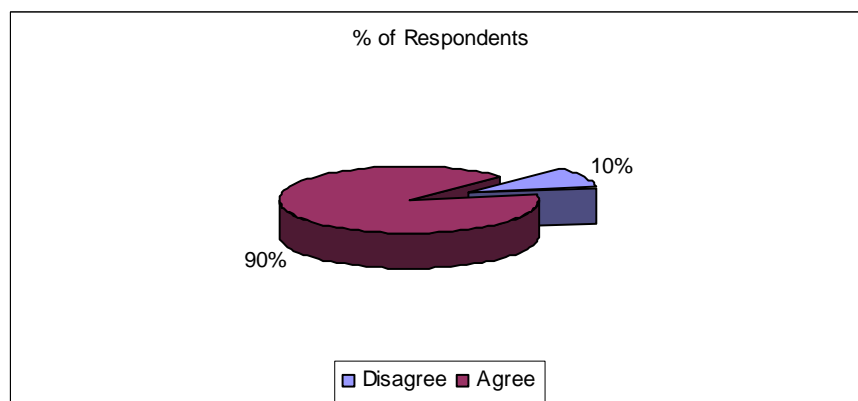

Figure 5.7 – Tools Factor Mechanism Evaluation Responses (End User)

The respondents were lastly asked specific questions regarding the overall usability of the framework with regards to ‘An overall strategy to help smooth collaborative working’ and ‘A jargon free understanding of the service offerings, core competencies and resource availabilities’. There was considerable agreement by the participants in terms of the overall strategy of VECW with the help of the framework. However, there were some doubts specifically regarding the clients and other stakeholders’ understanding of the core competencies as reflected by 10% disagreement in Figure 5.9.. Figures 5.8 and 5.9 illustrate the responses through a pie-chart.



**Figure 5.8 – Overall Impact on Collaboration Evaluation Responses (Preliminary)**



**Figure 5.9 - Overall Impact on Collaboration Evaluation Responses (End User)**

In addition to the Likert scale questions, the evaluators were asked open-ended questions to ascertain the benefits, limitations and improvement possibilities to the current VECW framework. Section 5.4.2 discusses the evaluators’ feedback on these open-ended questions. This section is the direct result of the focus group discussions was obtained from the evaluation exercise.

#### **5.4.2 EVALUATOR’S FEEDBACK**

The evaluation was useful in identifying many benefits of the new framework as evident from Table 5.3 on the next page. However, certain limitations and barriers were also identified with regards to implementation of VECW Framework. Consequently the comments were considered with respect to the original objectives and divided into perceived barriers of the system or outside the scope of the current work (future research) as discussed in Table 5.4.

Lastly, Table 5.5 provides the enhancements that the evaluators would like to see in the framework.

The existing Associates were already feeling the positive impact of the VECW framework, since the Collaboration Charter was fully incorporated for any new Associates wanting to be part of ServQ’s collaboration. In addition, the IDEF0 diagrams of ServQ’s collaboration were directly used for identifying the process owners as well as types of documents for evidence gathering when ServQ applied for ISO9001 status. Associates feel that the framework in its totality provides the ‘ground rules’ for collaboration. Two of the new Associates felt that the VECW framework provides, in a written format, an idea about the proportion of individual outcomes of collaboration distributed among the stakeholders and they are fair to most extents. For example, the framework helps identify and justify the effort of a particular Associate in finding a prospective project, help in developing the tender document and eventually, be part of the project team. Hence, the Associate needs to be financially remunerated accordingly.

In terms of individual mechanisms, the stakeholders feel the Collaboration Charter provides stakeholder participation in ServQ collaboration right from the start of the working relationship. IDEF0 diagrams provide a process model that is standard with uniform syntax leading to a well structured and clear understanding of the process model. Lastly, a roadmap prepared with the help of the Scenario Planning ensures the portfolio of tools are understood by the stakeholders.

**Table 5.3 – Benefits of the VECW Framework**

<b>Benefits</b>	<b>Evaluator's feedback</b>
<b>Facilitation of existing Associates</b>	* The present context will provide/facilitate more harmonious collaborative working practice among the existing Associates.
<b>Explicit Knowledge</b>	* Explicit and simple to understand. * Agreed set of 'Ground rules' for collaboration. * Perception of fairness among stakeholders since the framework has ability to ensure that individual outcomes of collaboration are in proportion and fair.
<b>Flexibility</b>	* The framework provides enough flexibility to ensure a wider operation among most SME service firms.
<b>Uniform syntax of Process model</b>	* By following the rules of IDEF0, a formal process is achieved which most stakeholders can follow. * Well structured and clear.
<b>Stakeholder participation</b>	* Stakeholders have a greater say within the collaboration due to enhanced participation at all levels of decision making. * Common understanding of 'Value Enhancement' consisting of a) higher motivation for collaboration; b) learning from each other for better project delivery; and c) awareness of tools and processes and its like to needs and issues.
<b>Roadmap for tools understanding</b>	* The framework provides a way of developing a roadmap to ensure professional development of Associates in the portfolio tools of the collaboration.

However, some barriers to the current VECW framework were also discussed during the evaluation exercise. One of the barriers raised by most evaluators during the preliminary evaluation was the integrated effect of all the three mechanisms. Once the mechanisms were in place, the evaluators felt there might be new issues introduced due to the combined use of the mechanisms. These issues need to be analysed over a sustained period of time with respect to the VECW framework. The induction of new stakeholders in the VECW framework would take some time and since the rate of attrition is high in SMEs like ServQ, it would create issues. Since, many of the current stakeholders are individual self-employed Associates, there has been a disparity between mechanisms used in a collaborative environment with such individuals and affiliate organisations, since affiliate organisations would have their own sets of mechanisms. According to the evaluators, with self-employed individuals it is relatively less complex to use the VECW framework for enhancing collaboration as compared to large organisations. This is because large affiliate organisations would have their own way of working and they might be not as flexible as individual Associates. The evaluators felt that the system might not be as successful with the organisations as with self-employed individuals. Lastly, most evaluators felt that the framework would work best in tandem with regular face-to-face meetings.

**Table 5.4 – Barriers to VECW framework**

<b>Barriers</b>	<b>Evaluator's feedback</b>
<b>Combined effect of the all factors</b>	* The integrated effect of all the three factors (i.e. People, Process and Tools) can lead to unique issues not perceived before and hence they should be analysed with respect to VECW framework.
<b>Time frame</b>	* The work consists of a sustained investment in terms of time among the stakeholders and in real time many Associates would not get a chance to go through the system before starting work within ServQ's collaborative environment. * SMEs and Associates can have high levels of attrition and hence re-inducting new Associates in the framework can be time consuming.
<b>Wider implication</b>	* Any change in agreements between the stakeholders can implicate changes to several relationships (between different stakeholders) if not communicated in real time.
<b>Ego</b>	* The presentation of the framework should ensure that it doesn't sound as a 'classroom teaching' for professionals to learn how to collaborate.
<b>Facilitation of affiliate networks</b>	* The VECW framework is more in tune with facilitation of individual Associates to join ServQ collaboration. However, the facilitation to collaborate with affiliate companies is not covered to a great length.
<b>Face-to-face time</b>	* There is no replacement for regular face-to-face contact. Hence, the framework can be useful only in the presence of a mechanism to meet regularly formally or informally.

Evaluators also suggested certain enhancements to the VECW framework based on their experiences. Further improvements were made to the framework specifically in terms of developing an overall VECW framework guideline. The guideline should provide short to long term target changes within each of the People, Process and Tool factor. The guideline

was based on the conditions of ServQ and it was divided into strategic, organisational and operational phases. According to the needs of ServQ, the guideline points were prioritised to give more focus to the value enhancement of collaboration.

**Table 5.5 – Suggested enhancements to VECW framework**

	<b>Improvement possibilities</b>	<b>Comments</b>
<b>Collaboration Charter</b>	A section within the Collaboration Charter outlining the specific needs or terms of the Associate.	This option was discussed with the Directors at the start of the work on Collaboration Charter. Since the Collaboration Charter is envisaged as a unique document prepared in facilitation with the Associate, the needs of an Associate would be indirectly included within the collaboration charter.
	People issues are highly complex and hence changes might need to be introduced based on the results of the model working for a sustained period of time.	This would be ascertained through the periodic review process of the collaboration charter.
<b>Risk identification</b>	The VECW framework provides an ideal case of problem solving, however there are uncertainties in business and it may be worth to identify the associated risks to the project delivery and some mitigation activities.	This is a useful suggestion. It is partially fulfilled by setting a periodic review process of the framework that helps to use the lessons learnt from past issues. However, a concentrated effort of risk identification and mitigation can also be carried out.
<b>Prioritising guidelines</b>	The VECW guidelines are a good roadmap to follow. However they need to be further refined and priorities set for optimising the collaboration improvement effort.	It is an excellent suggestion. As part of the conclusions the research provided guidelines with priorities.

## 5.5 GUIDELINES FOR VECW FRAMEWORK

Based on findings of the individual factors responsible for VECW and the suggestion for enhancement of the VECW framework, guidelines for the framework were developed to help ServQ chart a roadmap for sustaining long term collaboration and performance improvement within their collaborative environment. The VECW initiatives and mechanisms needed to realise that people within ServQ’s collaborative environment are gaining from working with each other within this arrangement. Hence, the ServQ Directors demonstrate the value of CW by adopting the VECW guidelines framework (Figure 5.10) to provide them with the right resources to ensure the issues with CW in ServQ are handled in a structured way. To achieve this, the framework was developed in a way to integrate the operational, organisational as well as the strategic processes. There was a conscious effort to consider the fact that, as a small organisation, the boundaries between these processes were very fluid.

The guidelines considered each of the ServQ CW issues identified in the preliminary case study. The framework divides these issues into People, Process and Tools factors and provides individual guidelines against the Strategic, Organisational and Operational processes. The resulting guidelines generated are arranged according to the chronological order within each



of these sections. Lastly, with the help of colour coding, these guidelines are prioritised in terms of ongoing or finished activities, short term activities (less than 6 months) and medium term activities (2-3 years). This exercise helps to chart the progress at the end of each of these activities to conclude the progress of VECW within ServQ. All the activities within sections of this guideline framework are best suited when employed complementarily with other sections of that framework. Hence, these activities need to go through the monitor-feedback cycle (Plan-Do-Check-Act).

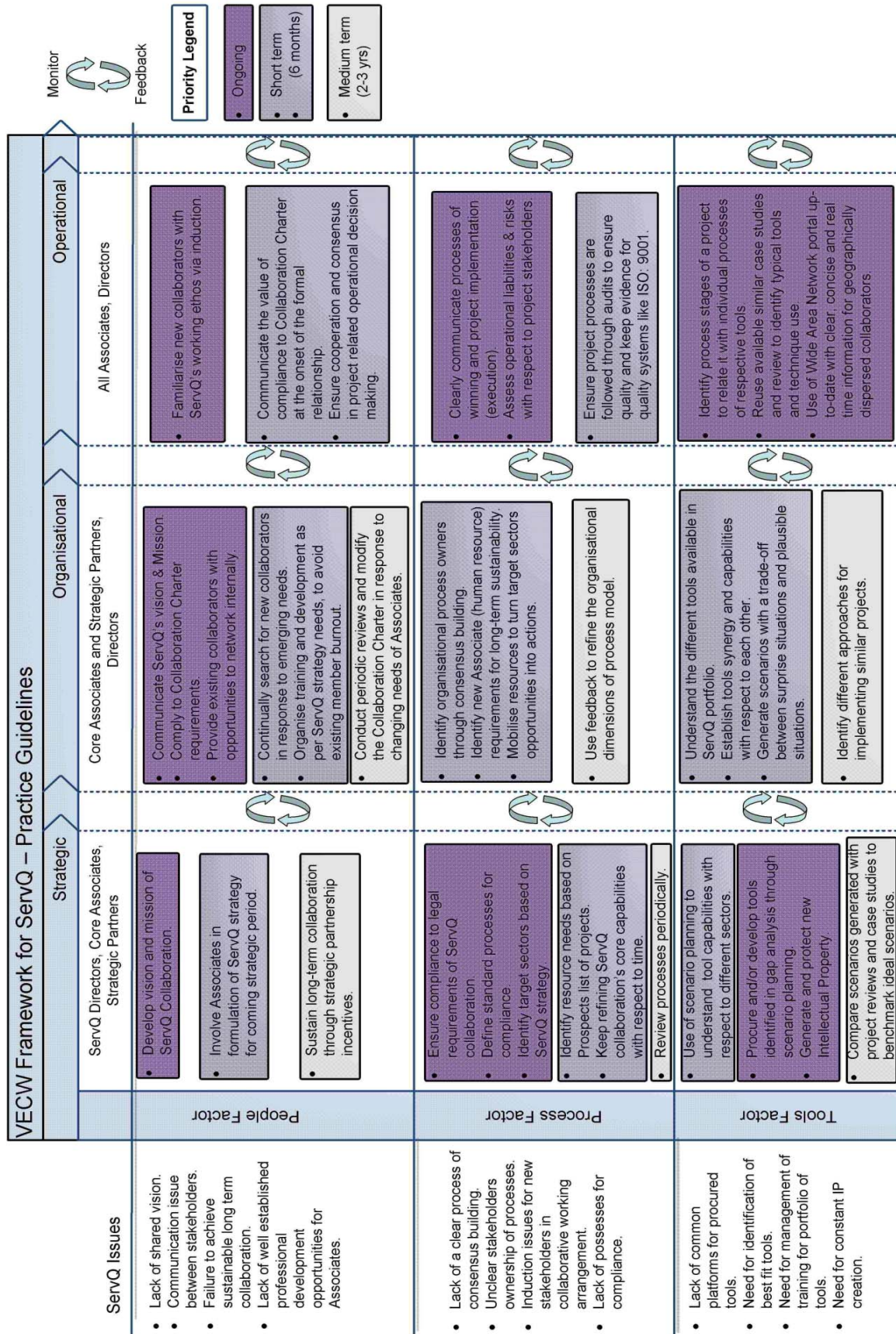

Figure 5.10 - Guidelines to VECW Framework for ServQ

Similarly, based on findings within People, Process and Tool factors responsible for VECW, guidelines for the VECW framework can be developed to help chart a roadmap for sustaining long term collaboration and performance improvement within their collaborative environment. Figure 5.11 below illustrates a broad-purpose VECW template for collaboration in service organisations.

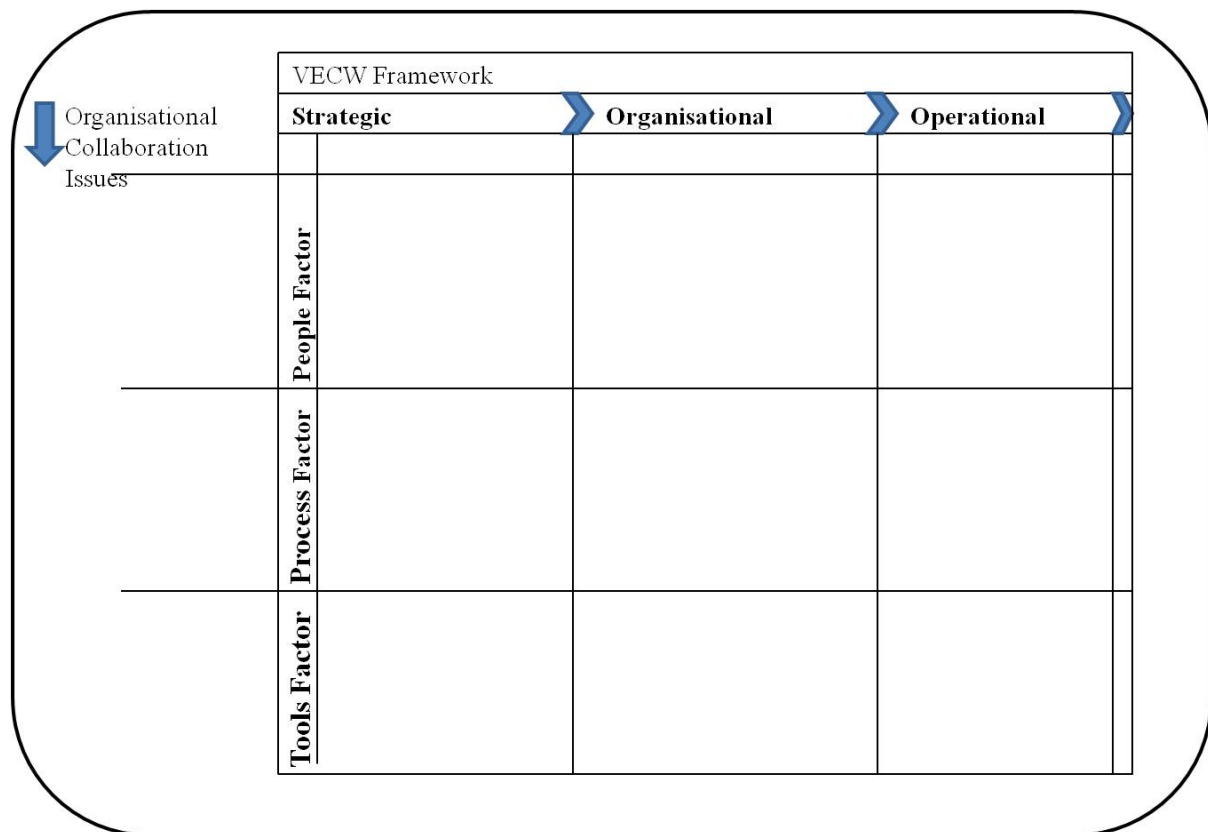

Figure 5.11 – VECW Framework Broad-Purpose Template

## 5.6 SUMMARY

This chapter provided an explanation of the evaluation process carried out in the research project. In addition, it presented the results of the evaluation process which collected feedback from both prospective and current users of the framework. In general, the feedback was positive from the evaluators and they felt that the research was relevant to the needs of the industry as well as the case study in question. The evaluation also identified the advantages, barriers and possible improvements within the VECW framework. Lastly, the guidelines for VECW framework in the context of ServQ were discussed. The guidelines to VECW framework for ServQ developed at the end of the evaluation exercise along with the priority within each of the mechanisms at operational, tactical and strategic levels. This guideline, developed in conjunction with the ServQ Directors, provides the next steps to implement the VECW guidelines. The last chapter will provide the concluding comments on the research work along with the future research possibilities.



## 6 CONCLUSIONS

### 6.1 INTRODUCTION

This chapter is the summary of key research findings. It relates directly to the overarching aims and objectives of the research project. The aim of the research was to investigate the potential of VECW in a SME service firm. The issue in a SME service firm like ServQ was the inability to sustain consistent long term external collaborations with external collaborators due to typical collaboration issues. This research was important since in the current financial climate, there are a number of SME organisations that may fail to exist if they do not know the mechanism to sustain consistent long term collaborations. This is especially the case when the business model demands such organisations remain small and lean, as much as possible.

### 6.2 REALISATION OF AIMS AND OBJECTIVES

The aim of the research led to three main steps:

- To investigate patterns of CW within the sponsoring organisation and to identify areas of improvements;
- To further investigate the identified areas for process improvements in isolation; and
- To develop a comprehensive framework to enhance CW.

To further investigate the above mentioned points, the research was divided into the following objectives.

*Objective 1 - Understand the foundations of CW and Value with respect to SME service industry.*

The work on objective 1 started with the appraisal of collaborative working practices. A review of Value and Values helped to identify the part it plays in the shaping of collaboration within the organisation. The appraisal of CW was helpful in ascertaining the future work challenges for SMEs involved in CW. Lastly, the research work within objective 1 assisted in understanding ServQ's portfolio of tools and techniques.

*Objective 2 - To investigate patterns of CW within ServQ, and to identify areas of process improvements.*

This objective was responsible for understanding the existing CW arrangement of ServQ. It was responsible for identifying the successes and the issues with the current arrangement. The identified issues led to a need to improve CW in ServQ with the involvement of collaborators in strategic and organisational processes along with operational processes. In addition, it identified the motivations of individual collaborators and provided a chance for further training and development of collaborators. Lastly, effort was put into integration of ServQ tools by establishing synergy. All improvements were kept under three separate but interrelated factors: People, Process and Tools.

*Objective 3 - To further investigate the identified concern areas for process improvements in isolation.*

This objective was achieved by dividing the work into three distinct phases. In the People factor, a case study of ServQ collaborators identified the need for changing the existing partnership agreement to a Collaboration Charter. The Collaboration Charter recommended consideration of development of trust and commitment within ServQ and its Associates. Stress was laid on better communication and periodic review of the Collaboration Charter. Lastly, it helped to roadmap the induction of new collaborators.

The second part of the objective considered the Process factor. Lessons learned from ServQ's work arrangement showed a need to identify the important processes not only at operational level but even at strategic and organisational level. ServQ and its Associates had developed a well-defined process map at the operational level. Since ServQ is an SME depending on collaborators, a process model with process ownership was deemed necessary to clearly communicate the process ownerships as well as the resources available to carry out the required activities. The result was an IDEF0 process map.

The last part of third objective was related to the Tools factor. The objective to identify synergy between the tools in ServQ's portfolio was achieved using scenario-planning exercise. The scenarios illustrated issues of combining the tools since they are all on different platforms and have different IP considerations. However, the interaction of different tools on ServQ projects found the possibility to use the tools sequentially by using outcome of some tools as inputs for other tools.

*Objective 4 - To develop and evaluate a comprehensive framework to enhance CW.*

This objective was achieved by putting together each of the three factors and their mechanisms discussed in the previous objective. It was followed by an evaluation of their impacts on the original issues of collaboration in ServQ. The evaluation responses recognised the ability of these mechanisms to solve several CW issues. However, it also pointed out the need to prioritise issues according to the situation of the collaborative environment of the organisation.

*Objective 5 - To identify the managerial implications of the research.*

Based on the evaluation findings, a guideline to the VECW framework for ServQ was prepared along with the priorities of different activities. Lastly, it identified the current progress of the different activities/processes as mentioned in the VECW framework.

### **6.3 CONTRIBUTION TO EXISTING THEORY AND PRACTICE**

This research considered the existing theory and practice prevalent in a wide variety of industries and then focused on SME services organisation. It is different from previous research as they did not always consider such a holistic approach. This approach covered different aspects of collaboration with the help of unique mechanisms related to the diverse factors. The value of collaborative working increases only when it is sustained over a long period of time. The research has looked at assessing this value with the help of different value attributes (such as building trust, commitment, fluid organisational boundaries, innovation, etc.) that were improved based on the assessment of people involved in a collaborative network.

The research examined the challenges of collaborative working arrangements. These CW arrangements were assessed in the context of small services organisations. In particular, the research deals with firms that might have very limited personnel resources and consequently, rely very heavily on its collaborators for many management processes. Such an arrangement provides particular benefits like reduction in organisational administrative costs and greater availability of different skills that are so important for service organisations. However, it has also created issues such as inability to sustain such collaboration especially when new projects dried up due to inability to win more work.

The research studied the effects VECW would have in terms of providing a framework for ensuring a template for sustainable collaboration. It contributed to existing collaborative working by providing more information on how to extend these broad areas in the fields of services environment and SMEs. Lastly, the important contribution of this research was to bridge the gap between the theoretical successes and barriers of CW to practice.

## **6.4 IMPLICATIONS / IMPACT ON SPONSOR**

This research was sponsored with the original aim of performance improvement within ServQ. At the start of the project, the sponsors thought the best way forward for performance improvement was to combine the different tools available within its portfolio to give a ‘one stop solution’ to address clients’ needs. However, the preliminary investigation of this research eliminated this perception by identifying issues that needed to be solved with the help of other mechanisms. The impact on ServQ can be summarised through the following main areas:

### **6.4.1 IDENTIFYING SERVQ ISSUES**

Organisations such as ServQ are quite small and they regularly fail to see their overall strategic work patterns since they are always busy trying to find new projects or complete existing projects. This is a direct result of multiple tasking of all employees within the organisation. This research ensured that a diagnosis of the current collaborative work structure was carried out to find out the reasons behind the current work structure as well as the barriers within this system. A direct result was the identification of holistic collaborative issues faced by ServQ’s collaborative working arrangement currently.

### **6.4.2 IMPROVING COMMUNICATIONS AND RELATIONSHIPS**

The research improved the efficiency and efficacy of dealing with specific concerns related to CW such as communication issues, trust and commitment issues, and improvement in relationships within the collaboration. By adopting the Collaboration Charter and discarding the previous partnership agreement, the industrial sponsor recognised the need to evolve their collaborative relationships into a flexible arrangement. It provided them with a platform to induct new collaborators by understanding their needs and communicating their own priorities to the collaborators. In addition, the Collaboration Charter not only highlights the contractual obligations of both the parties but also the expectations of each other, promotes training and development and should be reviewed periodically.

### **6.4.3 IMPROVING PROCESSES**

Mapping ServQ's activities and its collaborators and developing it into a comprehensive IDEF0 model ensured that all concerned parties of ServQ knew the processes involved in collaborating with ServQ. IDEF0 helped to document and summarise all the major activities. Most importantly, it provided process ownership and ensures that collaborators have a greater chance to get involved in ServQ's strategic and organisational activities to further develop their careers while generating constant business in terms of projects for ServQ's collaborative enterprise. The process map proved to be important evidence for getting ISO 9001:2001 accreditations.

### **6.4.4 CRITIQUE OF EXISTING TOOLS**

The research provided an opportunity to objectively look at the different tools available within ServQ's portfolio and compare it with the type of services that ServQ plans on offering. The desk study of the tools resulted in an internal critique of existing tools. The result of this report was the creation of a base for organisational process changes to codify the successful practical experiences. In addition the scenario generation exercise provided a coherent approach to acquiring tools by pointing to obvious gap in the tools portfolio and provision for client services by ServQ. Although it was important to conclude the fallacy of trying to generate a 'one stop solution' tool consisting of all the ServQ tools and techniques. This was because the tools were developed by different industries and were on different user interfaces (for e.g. software, questionnaire, self-assessment, etc.). However, there was ample proof to show synergy among the different ServQ tools.

During the course of this research, good progress has been made in the fields of IT and information sharing with the advent of emerging 'Web 2.0' type technologies such as cloud computing, information sharing sites, twitter, social networking sites, wikis, blogs, instant messaging and mobile tools. All these tools are a form of information sharing and it is for the organisation and its collaborators to start exploring them to better exploit information sharing. However, these technologies are evolving very rapidly and the uptake of such technologies might be more for 'tech-savvy' professionals.

### **6.4.5 HOW TO USE THE VECW FRAMEWORK**

Lastly, the guidelines for using the VECW framework helped to prioritise the different activities to carry out within People, Process and Tools factors in scope of strategic, organisational and operational activities. The priorities and a time constraint on individual activities within the framework as well as the current state of these activities help ServQ to plan its future roadmap.

## **6.5 IMPLICATIONS / IMPACT ON WIDER INDUSTRY**

Government has started realising the need to consider bids by SMEs for large government projects (DTI, 2005). However, the SMEs do not have the resources, qualifications or experiences to develop, submit and win major public sector bids and hence, SME collaborations are the only viable options by which they can win government bids. However, this industry would require a sustainable CW arrangement that can be duplicated across the industry. The example of the VECW framework as a collaborative framework may be duplicated and adopted by other organisations.



In the current financial climate, downsizing of big organisations is a common phenomenon seen across the industry. The result of this downsizing is the sudden burst of aspiring entrepreneurs getting out of work and starting their own businesses. Hence, the current VECW framework should be an ideal uptake for any industry wanting to remain lean in its expenses while providing an opportunity to provide services in their core competencies and beyond.

A key issue of the SMEs currently working in Service industry is that they know the importance of collaborating, however, they are unable to formulate a way to do it consistently and over a sustained period of time. Hence, for such SMEs it is highly important to find a solution to this problem. The current work provides them with a VECW framework to ensure that they have an approach which can be tailored to suit the objectives and needs of their organisation. The framework can be tailored according to the business size and sector within the service industry based on the basic principles learned from the current research.

The research undertaken helps them to communicate better with the help of the Collaboration Charter; this can be used as a more inclusive collaboration agreement as compared to contemporary partnership contracts. The availability of a wide variety of tools and technologies for management purposes in the service industry has meant that different SMEs use different tools. This research has noted the importance of keeping all the collaborating partners informed about their current resources (tools) to best exploit them. Lastly, the VECW framework provides a way to undertake and bid for work in a consistent manner. The result of such a provision is the communication of the expectations of finding new projects to the collaborators in a clear and consistent manner throughout.

## **6.6 CRITICAL EVALUATION OF RESEARCH**

A prerequisite to successful EngD completion is the attainment of academic as well as commercial needs of a project. This requirement wielded demands on balancing both the sets of needs. The research has been successful in responding to both the sets of needs.

The result of this was the realisation, after the preliminary case study that the SME working arrangement had to be looked at in detail to actually improve the CW within the sponsoring organisation. This resulted in dividing the research into first development of a conceptual VECW framework, followed by individual projects to develop individual mechanisms for the components (i.e. factors) of the framework. This heavy reliance on the sponsoring organisation resulted in slow progress at the start of the research until all the important collaborators (dispersed geographically) understood the importance and requirements of this work.

In addition, the change of leadership (within the industrial sponsor) several times led to lack of continuity of the research. It also resulted in lack of focus at times on the research work. However, this was settled on the latter stages of the research.

To meet the primary demand of the EngD programme of making an impact on the sponsoring organisation, a case study research approach was adopted. This required full

access to the sponsoring organisations resources including access to sensitive information. Gradual work progress and outputs created a sense of commitment of the researcher towards the sponsoring organisation. This resulted in easy access to the required resources to create a framework supported by the sponsoring organisation to make a lasting change to their CW practices.

It should be noted, however, that a longitudinal case study comes with its own sets of disadvantages. The over reliance on a single case study organisation for a research project over a period of four years was adequate in the current context. However, time permitting; access to other similar organisations would have further enhanced the research work. In return, the case study method resulted in a deep understanding of the organisation. This was especially important since the work directly dealt with the people aspects of collaboration and it was considered very important to understand the requirements of each of the stakeholders within or outside of ServQ.

Another issue was that ServQ was a SME consisting of very few employees. It meant that the same set of people had to be interviewed and involved in developing each of the mechanisms throughout the research work. Only at the end, another set of potential collaborators were used to evaluate the overall research work.

It was anticipated that the research under objective 5, developing the VECW framework guidelines and the overall evaluation of VECW framework, would lead to a fourth journal paper. Whilst the objective was achieved and discussed in the conclusion chapter of the document, the academic paper is still in progress. It was not achieved due to EngD timeframes; however the paper will be written and submitted by the mid of 2011.

## **6.7 RECOMMENDATIONS FOR FURTHER RESEARCH**

This section provides recommendations for further research. It also proposes a different view on VECW once the sponsoring organisation reaches maturity in the current model.

- The evaluation of the VECW framework also suggested enhancing the framework by putting in place risk identification and mitigation process in place. The risk identification and mitigation process is directly related to the uncertainties in business and its associated risks, especially external risks. Citing the example of Reason's (1990) work on aviation safety, the evaluators suggested that failure of collaboration in any organisation can be traced due to any of the individual factors or against the combined or knock-on effects of these factors. This can be best understood by Figures 6.1 and 6.2. After the organisation attains maturity, the study of the periodic reviews may enhance this information for further refining the VECW framework according to the needs of the individual organisations.

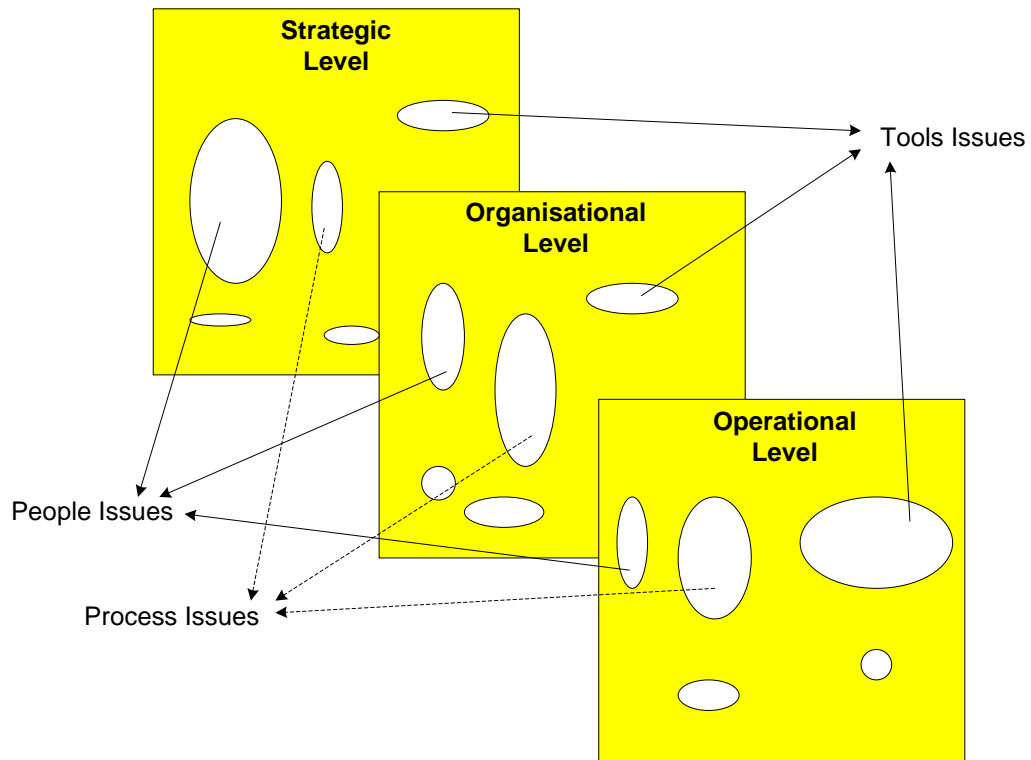

Figure 6.1 – The Swiss cheese model of collaboration Issues (adopted from Reason, 1990)

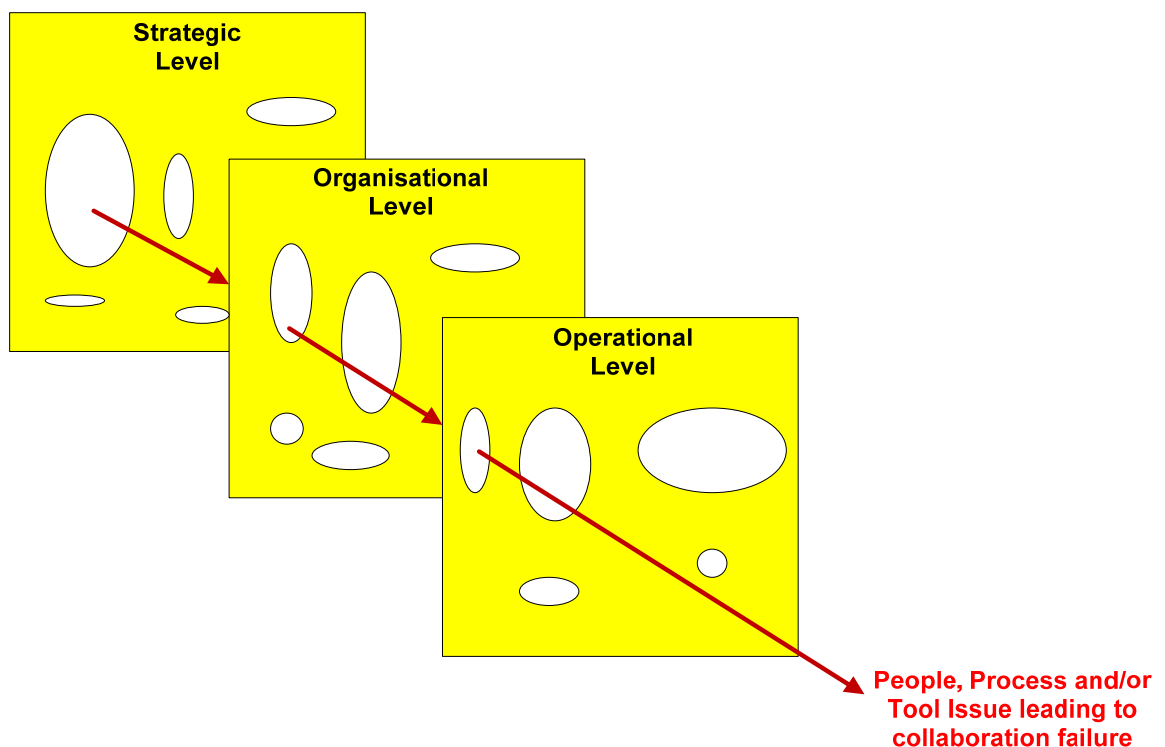

Figure 6.2 – Collaboration issues passing through each level (adopted from Reason, 1990)

- The current research was a longitudinal study of a single case study (ServQ) organisation. It was interesting to see the effect of the current framework on a wide variety of small businesses covering different service sectors such as legal services, high tech/Software companies, marketing and advertising firms,

publishing firms, etc. All these firms are part of the service sector but might have different issues when engaging in collaborative working environments.

- The academic evaluators felt that the current research responds more to individual collaborators (Associates) working collaboratively with the sponsor organisation. Since, different SMEs do collaborate with each other, it would be interesting to study if the framework still holds true in b-2-b (business to business) collaboration context at an SME level i.e. collaboration among SME clusters.

## **6.8 CONCLUSIONS**

Collaboration of some sort is now indispensable part of most organisations especially for SME firms. This research is an extension to the growing volume of research in the field of collaborative working. It particularly deals with the issues faced by service industries in collaboration. It presents a structured approach to CW by first examining the most important factors responsible for sustaining long-term VECW. The result is an overall VECW approach that focusses on People, Process and tools factors. With the help of mechanisms such as Collaboration Charter, Process Mapping and Scenario Planning, as provided in this research, the service organisations can implement the VECW framework.

The implications for industry are significant in terms of sustaining CW over a long period in service industry. The VECW framework provides a way to ensure the development of trust, commitment and communication important for building collaborative relationship while the process map provides a potential for increased ownership of processes as well as engagement within collaborators. From this perspective, this research was successful in significantly improving ServQ's collaborative working through the development of a VECW framework to sustain long term collaboration in ServQ.

## 7 REFERENCES

- Alarcon, L.F. (1997), *Lean Construction*, A.A. Balkema Publishers, Rotterdam
- Anand, B. and Khanna, T. (2000), 'Do firms learn to create value? The case of alliances', *Strategic Management Journal*, Vol. 21(3), pp. 295-315
- Anderson, J.C., Jain, D.C. and Chintagunta, P.K. (1993), "Customer value assessment in business markets: a state of practice study", *Journal of Business to Business Marketing*, Vol. 1(1), pp. 3-30
- Anumba, C.J., Ugwu, O.O., Newnham, L. and Thorpe A. (2002), 'Collaborative design of structures using intelligent agents', *Automation in Construction*, Vol. 11(1), pp. 89-103.
- Attaran, M. and Attaran, S. (2002) 'Collaborative computing technology: the hot new managing tool', *Team Performance Management: an International Journal*, Vol. 8(1/2), pp. 13-20.
- Aguilar-Saven, R.S. (2004). 'Business process modelling: Review and framework', *International Journal of Production Economics*, Vol. 90(2). pp 129-149.
- Austin, S., Baldwin, A., Hammond, J., Murray, M., Root, D., Thomson, D. and Thorpe, A. (2001), *Design Chains – A handbook for Integrated Collaborative Design*, Loughborough University
- Baker, M. (2003), *Business and Management Research: How to complete your research project successfully*, Westburn Publishers Ltd, Argyll, Scotland
- Barthelmeß, P. (2003), 'Collaboration and coordination in process-centered software development environments: a review of the literature', *Information and Software Technology*, Vol. 45(13), pp. 911-928
- Barratt, M., Choi, T.Y. and Li, M., (2010), "Qualitative Case Studies in Operations Management: Trends, Research Outcomes, and Future Research Implications", *Journal of Operations Management*, Vol. 28(4), pp. 329 - 342
- Belderbos, R., Carree, M. and Lokshin, B. (2004), 'Cooperative R&D and firm performance', *Research Policy*, Vol. 33(10), pp. 1477-1492
- Bennett, J. and Jayes, S. (1998), *The Seven Pillars of Partnering: Guide to second generation partnering*, Thomas Telford Ltd.
- Blomqvist, K., Hurmelinna, P. and Seppanen, R., (2005), 'Playing the collaboration game right – balancing trust and contracting', *Technovation*, Vol. 25(5), pp. 497-504
- Boddy, D., Cahill, C., Charles, M., Fraser-Kraus, H. and Macbeth, D. (1998), 'Success and failure in implementing supply chain partnering: an empirical study', *European Journal of Purchasing & Supply Management*, Vol. 4(2), pp. 143–151
- Bradfield, R., Wright, G., Burt, G., Cairns, G. and Van Der Heijden, K. (2005), "The origins and evolution of scenario techniques in long range business planning", *Futures*, Vol. 37(8), pp. 795-812
- Brochner, J. (1995), "Pattern Transfer; Process Influences on Swedish Construction of the Automobile Industry", Proc. 3rd Workshop on Lean Construction, Albuquerque, USA
- Bridgeland, D.M. and Zahavi, R. (2009), *Modelling Fundamentals: Business Modelling*, Kluwer Academic Publishers
- Bruno, L.F.C. and Lay, E.G.E. (2008), "Personal values and leadership effectiveness", *Journal of Business Research*, Volume 61(6), pp. 678-683

- Bryman, A. and Cramer, D. (1990), *Quantitative Data Analysis for Social Scientist*, Routledge, London
- Brymann, A. and Bell, E. (2003), *Business Research Methods*, New York, Oxford University Press
- Burt, R., (1997), 'The contingent value of social capital', *Administrative Science Quarterly*, Vol. 42(2), pp. 339-365
- Cardell, S. (2002), *Strategic Collaboration*, Hodder Arnold, London
- Child, J., (2001), 'Trust – The fundamental bond in global collaboration', *Organisational Dynamics*, Vol. 29(4), pp. 274-288
- Coakes, E.W., Coakes, J.M. and Rosenberg, D. (2008), 'Co-operative work practices and knowledge sharing issues: a comparison of viewpoints', *International Journal of Information Management*, Vol. 28(1), pp. 12-25
- Coakes, S. and Steed, L. (2003), *SPSS: Analysis without Anguish*, Milton: John Wiley and Sons Ltd
- Cormack, D.S. (1991), *The research process*, Black Scientific, Oxford
- Cox, A. (2001), "Understanding buyer and supplier power: a framework for procurement and supply competence", *The Journal of Supply Chain Management*, Vol. 37(2), pp. 8–15
- Creplet, F., Dupouet, O., Kern, F., Mehmanpazir, B. and Munier, F. (2001), 'Consultants and experts in management consulting firms', *Research Policy*, Vol. 30(9), pp. 1517-1535
- Creswell, J. (2003), *Research Design: Qualitative, Quantitative, and Mixed Methods Approaches*, Thousand Oaks, California: Sage Publications
- Cullen, J.B., Johnson, J.L. and Sakano, T. (2000), 'Success through commitment and trust: the soft side of strategic alliance management', *Journal of World Business*, Vol. 35(3), pp. 223-240
- Dainty, A. (2005), 'Methodologies for construction management research', *Research, Innovation & Communication Lecture Notes*, Loughborough University, UK
- Dainty, A., Bryman, A., and Price, A. (2002), "Empowerment Within The UK Construction Sector", *Leadership and Organization Development Journal*, Vol. 23(6), pp. 333-342
- Das, T.K. and Teng, B-S. (2000), 'A resource based theory of strategic alliances', *Journal of Management*, Vol. 26(1), pp. 31-61
- Daugherty, P., Glenn Richey, R., Roath, A.S., Min, S., Chen, H. , Arndt, A.D. and Genchev, S.E. (2006), 'Is collaboration paying off for firms?', *Business Horizons*, Vol. 49(1), pp. 61-70
- Department of Trade and Industry (1998), *Rethinking Construction: The Report of the Construction Task Force*, London: HMSO
- Department of Trade and Industry (DTI), (2005), 'A study of the benefits of public sector procurement from small businesses', *Small Business Service*, Department of Trade and Commerce.
- Driskell, J. E., Hogan, R., & Salas, E. (1987), 'Personality and group performance', In C. Hendrick (Ed.), *Personality and Social Psychology Review* (pp. 91–112). Beverly Hills, CA: Sage
- Drozdow, N. and Carroll, V.P. (1997), 'Tools for strategy development in family firms', *Sloan Management Review*, Vol. 39(1), pp. 75-88
- Easterby-Smith, M; Thorpe, R. and Lowe, A., 1991, *Management Research: An Introduction*, Sage Publications, London.

- Emmitt, S and Christoffersen, A.K. (2008), "Collaboration and communication in the design chain: a value-based approach", in O'Brien, W.J., London, K.A., Vrijhoef, R. and Formoso, C.T. (Eds.), *Construction Supply Chain Management Handbook*, CRC Press, USA
- Ellis, S., Klahr, D. and Siegler, R. S. (1993), 'Effects of feedback and collaboration on changes in children's use of mathematical rules', *Society for Research in Child Development*. New Orleans.
- European Foundation for the Improvement of Living and Working Conditions, (2005), 'Sector Futures – The Knowledge-Intensive Business Service Sector', *Report by European Monitoring Centre on Change*, pp. 2-29
- European Commission (2005), *The New SME Definition: User guide and model declaration*, Enterprise and Industry Publications, EC.
- Faulkner, D. (2006), Strategic Alliances and Networks, in Faulkner, D. and Campbell, A. (ed.), *Oxford Handbook of Strategy*, Oxford University Press
- Fellows, R. and Liu, A. (2006), *Research Methods for Construction*, Blackwell Publishing, Oxford
- Fisher, D.J. (1995), "The Knowledge Process", Proc. 3rd Workshop on Lean Construction, Albuquerque, USA
- Frankel, R., Smitz Whipple, J. and Frayer, D.J., (1996), 'Formal versus informal contracts: achieving alliance success', *International Journal of Physical Distribution and Logistics Management*, Vol. 26(3), pp. 47-63
- Futrell, R., Shafer, D. and Shafer, L. (2002), *Quality Software Project Management*, Upper Saddle River, N.J.: Prentice Hall PTR
- Gale, B.T. (1994), *Managing Customer Value*, Free Press, New York
- Gill, J. and Johnson, P. (2002), *Research Methods for Managers*, Sage Publications, London
- Gomes-Casseres, B. (1996), *The Alliance Revolution: The New Shape of Business Rivalry*, Harvard University Press, Cambridge, MA
- Grant, R.M. (1991), *Contemporary Strategy Analysis: Concepts, Techniques, Applications*, Oxford: Blackwell Business
- Jim Grieses, (2000) "Introduction: the origins of organizational development", *Journal of Management Development*, Vol. 19(5), pp.345 - 447
- Grimshaw, D. J. and Kwok, F. T. Sandy (1998), *The Business Benefits of the Virtual Organization in: The Virtual Workplace*, Idea Group Publishing
- Gustafsson, A. and Johnston, M. (2003), *Competing in a Service Economy*, Jossey Bass
- Hammond, J. H., Koubek R. J. and Harvey C. M. (2001), 'Distributed Collaboration for Engineering Design: A Review and Reappraisal', *Human Factors and Ergonomics in Manufacturing*, Vol. 11(1), pp. 35-52
- Handy, C. (1992), 'Balancing Corporate Power – A new federalist paper', *Harvard Business Review*, Nov-Dec, pp. 59-72
- Hart, O. and Moore, J., (1999), 'Foundations of incomplete contracts', *Review on Economic Studies*, Vol. 66(1), pp. 115-138
- Hausman, A. (2005), 'Innovativeness among small businesses: Theory and propositions for future research', *Industrial Marketing Management*, Vol. 34(8), pp. 773-782
- Hobday M. (2000), 'The project-based organisation: an ideal form for managing complex products and systems?' *Research Policy*, Vol. 29. pp. 871–93
- Hoffmann, W.H. and Schaper-Rinkel, W. (2001), 'Acquire or ally – A strategic framework for deciding between acquisition and collaboration', *Management International Review*, Volume 41(2), pp. 131-159

- Hosmer, L.T., (1995), 'Trust: the connecting link between organisational theory and philosophical ethics', *Academy of Management Review*, Vol. 20(2), pp. 370-403
- Hirschhorn, Larry (1980), 'Scenario Writing: A Developmental Approach', *Journal of the American Planning Association*, Vol. 46(2), pp 172 — 183
- Hultman, K. and Gellerman, B., *Balancing Individual and Organisational Values*, Jossey-Bass/Pfeiffer
- Huq, Z. (2005), 'Managing change: a barrier to TQM implementation in service industries', *Managing Service Quality*, Vol. 15(5), pp. 452-70
- International Monetary Fund (IMF) (1993), *Balance of Payment Manual*, 5th Edition at <http://www.imf.org/external/pubs/ft/bopman/bopman.pdf> last visited on 01st November, 2009
- Johnston, R. (2008), 'Internal service – barriers, flows and assessment', *International Journal of Service Industry Management*, Vol. 19(2), pp. 210-231
- Jorgensen, B. & Emmitt, S. (2008), 'Lost in Transition: The Transfer of Lean Manufacturing to Construction', *Engineering, Construction and Architectural Management*, Vol. 15 (4), pp. 383-398.
- Kakabadse, N.K., Louchart, E. and Kakabadse, A. (2006), "Consultant's role: a qualitative inquiry from the consultant's perspective", *Journal of Management Development*, Vol. 25(5), pp. 416-500
- Katrishen, F.A. and Scordis, N.A. (1998), 'Economies of scale in services: A study of multinational insurers', *Journal of International Business Studies*, Vol. 29(2), pp 305-323
- Kerzner, H. and Saladis, F.P. (2009), *Value-driven Project Management*, Wiley Publications: NY, USA
- Khalfan, M.M.A. (2001), 'Benchmarking and Readiness Assessment for Concurrent Engineering in Construction (BEACON)', PhD Thesis, Loughborough University, UK
- Kogut, B. (1998), 'Joint ventures—theoretical and empirical perspectives', *Strategic Management Journal*, Vol. 9(4), pp 319–332
- Koskela, L. (1992), *Application of New Production Theory in Construction*, Technical Report No. 72, CIFE, Stanford University
- Koutsikouri, D. (2009), *Individual and Collective Success: The Social Dynamics of Multidisciplinary Design Teamwork*, EngD Thesis, CICE, Loughborough, UK
- Kvan, T. (2000), 'Collaborative design: what is it?' *Automation in Construction*, Vol. 9(4), pp. 409 – 415, Elsevier Science
- Kvanli, A., Pavur, R. and Guynes, S. (2000), *Introduction to Business Statistics: A Computer Integrated Data Analysis Approach*, 5th Edition, Cincinnati: Thomson Learning
- Latham, Sir Michael (1994), *Constructing the Team: Final Report of the Government/Industry Review of Procurement and Contractual Arrangements in the UK Construction Industry*, London: HMSO
- LePine, J. A., Hanson, M. A., Borman, W. C., & Motowidlo, S. J. (2000), 'Contextual performance and teamwork: Implications for staffing', *Research in Personnel and Human Resources Management*, Vol. 19(1), pp. 53–90.
- Lu, S. C-Y., Elmaraghy, W., Schuh, G. and Wilhelm, R. (2007), 'A scientific foundation of collaborative engineering', *Annals of the CIRP*, Vol. 56(2), pp. 605-634
- Lupton, T. (1971), *Management and the Social Sciences*, Penguin, Harmondsworth



- Major, E.J. and Cordey-Hayes, M. (2000), 'Engaging the business support network to give SMEs the benefit of Foresight', *Technovation*, Vol. 20(11), pp. 589-602
- Marks, M.L. (1997), 'Consulting in Mergers and Acquisitions: interventions spawned by recent trends', *Journal of Organisational Change Management*, Vol. 10(3), pp. 27-41
- Maskin, E. and Tirole, J., (1999), 'Unforeseen contingencies and incomplete contracts', *Review on Economic Studies*, Vol. 66(1), pp. 83-114
- Maister, D.H. (1993), *Managing the professional service firm*, New York: Free Press
- May, A. and Carter, C. (2001), 'A case study of virtual team working in the European automotive industry', *International Journal of Industrial Ergonomics*, Vol. 27(3), pp. 171-186
- Maleyeff, J. (2006), 'Exploration of internal service systems using lean principles', *Management Decision*, Vol. 44(5), pp. 674-89
- McPherson, P.K. (1998), 'Business Value Modelling', *Aslib Proceedings*, vol. 50(7), pp. 154-172
- Melles, B. (1994), "What do we Mean by Lean Production in Construction?" Proc. 2nd Workshop on Lean Construction, Santiago, Chile
- Mills, A., (1998), 'Collaborative Engineering and the Internet', *Society of Mechanical Engineers*, Dearborn, Michigan
- Morris, L. L, Taylor Fitz-Gibbon, C. J. and Freeman, M. E (1987), *How to Communicate Evaluation Findings*, Newbury Park, CA: Sage
- Mount, M. K., Barrick, M. R., & Stewart, G. L. (1998), 'Five-factor model of personality and performance in jobs involving interpersonal interactions', *Human Performance*, Vol. 11, pp. 145-165.
- Mudambi, R., Helper, S. (1998), "The 'close but adversarial' model of supplier relations in the US auto industry", *Strategic Management Journal*, Vol. 19(8), pp. 775-792
- (The) Network for Construction Collaboration Technologies (2003), webpage at: <http://ncctp.constructingexcellence.org.uk/>, webpage last visited on 02/03/2011.
- Nicholas, J.M. (1994), 'Concurrent Engineering: Overcoming Obstacles to Teamwork', *Production and Inventory Management*, Vol. 35(3), pp.18-22
- Nourusis, M. (2004), *SPSS 12.0: Guide to Data Analysis*, New Jersey: Prentice Hall
- Nguyen, T., Rose, J., (2009), 'Building trust – Evidence from Vietnamese entrepreneurs', *Journal of Business Venturing*, Vol. 24(2), Pages 165-182
- OGC (2003), 'Achieving Excellence in Construction', *Building on Success*, OGC, London as seen on <http://www.ogc.gov.uk/documents/BuildingOnSuccess.pdf>, last reviewed on 25/11/2010.
- Osegowitch, T. (2001), 'The art and science of synergy: The case of the auto industry', *Business Horizons*, March-April, 2001, pp 17-24
- Park, S.H. and Ungson, G.R. (1997), 'The effect of national culture, organizational complementarity, and economic motivation on Joint Venture dissolution', *Academy of Management Journal*, Vol. 40(2), pp 279-307
- Porter, M.E. and Fuller, M.B., (1986), 'Coalitions and global strategy', in M.E. Porter (ed.), *Competition in global industries*, Harvard University Press, Cambridge, Mass
- Prasad, B. (1996), *Concurrent Engineering Fundamentals – Vol 1*, Prentice Hall, New Jersey
- Preskill, H. and Torres, R.T. (1999), *Evaluative inquiry for learning in organisations*, Thousand Oaks, CA. Sage Publications
- Reason J. (1990), *Human error*, New York: Cambridge University Press

- Remenyi, D., Williams, B., Money, A. and Swartz, E. (1998), *Doing Research in Business and Management*, Sage Publications, London
- Riddle, D.I. (1986), *Service-Led Growth: The role of service sector in world development*, Praeger Publications, New York
- Rittner, T. and Gemünden, H. G., (2003), 'Network competence: its impact on innovation success and its antecedents', *Journal of Business Research*, Vol. 56: pp. 745-755.
- Rosemann, M., de Bruin, T. and Power, B. (2006), 'A Model to Measure Business Process Management Maturity and Improve Performance', In Jeston, J.& Nelis, J. (Ed.): *Business process management: practical guidelines to successful implementations*, Burlington, pp. 299-315
- Rossi, P.H., Freeman, H.E. and Lipsey, M.W. (2004), *Evaluation: A systematic approach*, 7th edition, Thousand Oaks, CA. Sage Publications
- Rousseau, D., Sitkin, S., Burt, R. and Camerer, C., (1998), 'Not so different after all: A cross-discipline view of trust', *Academy of Management Review*, Vol. 23(3), pp. 393-404
- Sandhu, M.A. and Gunasekaran, A. (2004), 'Business process development in project-based industry', *Business Process Management Journal*, Vol. 10(6), pp 673-690
- Segal-Horn, S. (2006), Strategy in Service Organisations, in Faulkner, D. and Campbell, A. (ed.), *Oxford Handbook of Strategy*, Oxford University Press
- Segers, J., Inceoglu, I. Vloeberghs, D., Bartram, D., Hendericks, E., (2008), 'Proteon and boundaryless careers: A study of potential motivators', *Journal of Vocational Behaviour*, Vol. 73, pp. 212-230
- Shelbourn, M., Bouchlaghem, D., Anumba, C.J. and Carrillo, P.C. (2005), 'PIECC – Analysis and synthesis of Literature', *Planning and Implementation of Effective Collaboration within Construction as seen on* '[http://piecc.lboro.ac.uk/Results/D1\\_Literature%20Survey\\_1.pdf](http://piecc.lboro.ac.uk/Results/D1_Literature%20Survey_1.pdf)' last reviewed on 01/08/2010
- Shields, P.M. (1998), '*Pragmatism as a Philosophy of Science: A Tool for Public Administration*', available at '<http://ecommons.txstate.edu/polsfacp/33>' (assessed on 25th June, 2008)
- Silverman, David (Ed.), (2004), *Qualitative research: theory, method and practice* (second edition), London: Sage
- Strategic Forum for Construction (2002) Accelerating Change (Chairman: Sir John Egan)*, London: Rethinking Construction c/o the Construction Industry Council.
- Sydow, J., Lindkvist, L. and DeFillippi, R. (2004), 'Project-based organizations, embeddedness and repositories of knowledge: editorial', *Organisational Studies*, Vol. 25(9), pp. 1475–89
- Thompson, K. (2008), *The Networked Enterprise – Competing for the future through virtual enterprise networks*, Megan-Kiffer Press, Florida, USA
- Trochim, W. and Donnelly, J.P., (2007), *The Research Methods Knowledge Base*, 3rd edition. Thomson Publishing, Mason, OH
- Van Der Heijden, K. (1997), *Scenarios: The Art of Strategic Conversation*, Wiley Publications, New York
- Vergidis, K., Turner, C.J. and Tiwari, A. (2008), Business process perspectives: Theoretical developments vs. real-world practice, *International Journal of Production Economics*, Vol. 114(1), pp 91-104
- Wilkinson, P. (2005), *Construction Collaboration Technologies: The extranet evolution*, Taylor & Francis, London

- 
- Wolstenholme, A. (2009), *Never Waste a Good Crisis: A review of progress since Rethinking Construction and thoughts for our future*, Construction Excellence, London.
- Womack, J. P., Jones, D.T., and Roos, D. (1990), *The Machine that Changed the World*, New York, Rawson Associates.
- Woodhead, R. and Downs, C. (2001), *Value Management – Improving Capabilities*, Thomas Telford, London
- Woods, M. and Trexler, C.J. (2001), “Linking interpretive theory to practice: examining an underused research tool in agricultural education”, *Journal of Agricultural Education*, Vol. 42(2), pp. 68-78
- Wu, F. and Tamer Cavusgil, S., (2006), ‘Organisational learning, commitment and joint value creation in interfirm relationship’, *Journal of Business Research*, Vol. 59(1), pp. 81-89
- Yin, R. K. (1989), *Case Study Research – Design and Methods*, Sage Publications, Newbury Park, CA
- Yli-Renko, H., Sapienza, H. and Hay, M., (2001), ‘The role of contractual governance flexibility in realising the outcomes of key customer relationships’, *Journal of Business Venturing*, Vol. 16(6), pp. 529-555
- Zeithaml, V. A. (1988), ‘Consumer perceptions of price, quality and value: A means-end model and synthesis of evidence’, *Journal of Marketing*, Vol. 52(1), pp. 2–22
- Zeithaml, V.A. and Bitner, M.J. (1996), *Services Marketing*, McGraw-Hill International, New York
- Zuboff, S. and Maxmin, J. (2004), *The Support Economy*, Penguin Books: NY



## **APPENDIX A – PAPER 1 (JOURNAL)**

Gohil, U., Carrillo, P.M., Ruikar, K.D., Anumba, C.J., 2011, "Value-enhanced collaborative working: case study of a small management advisory firm", *Construction Innovation: Information, Process, Management*, Vol. 11, Issue 1, pp 43 – 60.

## **VALUE ENHANCED COLLABORATIVE WORKING: CASE STUDY OF A SMALL MANAGEMENT ADVISORY FIRM**

### **Structured Abstract**

**Purpose** - This paper proposes a conceptual framework to promote Value Enhanced Collaborative Working (VECW) for a small management advisory firm.

**Design/Methodology/Approach** – The research methodology was qualitative. It involved a comprehensive review of literature leading to a better understanding of collaborative working requirements in a small firm context and the barriers to derive value from collaborative working. Initially, exploratory observations helped to identify issues of collaborative working in the case study organisation. Following the exploratory observations, a detailed case study was undertaken. The emphasis was on semi-structured interviews under a guiding questionnaire along with field observations to produce a conceptual framework for VECW.

**Findings** - The research enables an understanding of the apparent failure of a particular SME management advisory firm (case study organisation) to derive value from its collaborative working model. The study identifies major issues that affect the long term relationships of the organisation with their collaborating stakeholders and recognises the common understanding required by the stakeholders working in collaboration. Further, in order to solve these issues, the research develops a conceptual VECW framework within the current context. The major components of the conceptual VECW framework consist of process, people and tools factors to give a structured approach to agree common goals, share risks and rewards, provide faster and clearer communications and information transparency between collaborating stakeholders.

**Research limitations/implications** – Due to the nature of the study (case study), current paper is based on the findings of a single SME management advisory firm. Hence, further research for organisations of similar size and providing similar services would be required to investigate the robustness of the approach.

**Originality/value** – Most studies on collaboration are concentrated on either larger organisations or product organisations. Here, the attempt is to understand the collaboration among small firms providing professional services. The research paper is an important milestone on an ongoing research to produce a detailed framework eventually to be presented to the industry for evaluation to ensure its contribution to the industry as well as increasing the knowledge on the subject.

**Keywords** - Collaboration, Value, SME, Conceptual framework

**Paper type** - Research Paper

## **INTRODUCTION**

Small and Medium Sized Enterprises (SMEs) are an important part of the global economy. Statistics show the volume of their contribution. For example, a Department for Business Enterprises and Regulatory Reform's (2007) survey shows that 99.2% of all UK firms are small enterprises, 0.6% are medium sized enterprises while 0.1% are large businesses, making SMEs a major part of the UK economy. Given this fact, it is an important part of our industry that cannot be ignored. The European Commission (1996) defined SMEs as independent firms with a headcount of less than 50 employees, either on the basis of an annual turnover, or balance sheet, with a total not exceeding 10 million Euros. 98.2% of the construction sector comprises of businesses that fall within this SME category (Construction Statistics Annual, 2007). It is, therefore a vital part of the construction sector that needs attention. A large part of their business relies on collaboration and partnering with other businesses. How successful or not the collaboration is, would depend on the collaborative arrangements between the companies. These collaborative arrangements should be able to overcome the inherent issues associated with such collaboration by allowing partners to pool resources, exploit complementarities and provide quick and flexible access to external resources (Das and Teng, 2000; Anand and Khanna, 2000; Hoffmann and Schaper-Rinkel, 2001; Belderbos *et al.*, 2004). Thus, collaborative working has the potential to enable people and organisations to work more effectively with stakeholders and perform combined actions across various cultural, disciplinary, geographic and temporal boundaries (Hammond *et al.*, 2001; Attaran and Attaran, 2002).

The SME collaborative arrangement would require partners or collaborators to derive value from this way of working in collaboration. The SME collaborations are a direct result of SMEs not always being able to develop their own competencies, widen their market, improve their services or not having enough human resources for winning or executing projects (Das and Teng, 2000; Belderbos *et al.*, 2004). The purpose of this research is to propose performance improvements for such SMEs through the introduction of Value Enhanced Collaborative Working (VECW) and to put forward a conceptual VECW framework. Hence, the motivation for this paper is to improve collaborative working within SMEs. Before describing the research methodology, a review of related work on aspects of collaborative working and value philosophies is presented below.

## **COLLABORATIVE WORKING**

### **Background and Context**

A wide range of literature is available under the umbrella of collaborative working. The current research work is in the context of SME and hence literature related to collaborative working in SMEs and management advisory firms has been reviewed. It was seen that SMEs frequently work with limited resources, be it monetary or work-force related. Personnel are often overloaded with multiple-tasks, which impact on organisational performance and efficiency (Major and Cordey-Hayes, 2000). In addition, their governance and reward structures are different (Hausman, 2005); and they usually have fewer external contacts to increase their adaptation capabilities in response to changes in the economic, technological or competitive markets (Drozdow and Carroll, 1997).

Specifically, professional services organisations like management advisory firms are often faced with situations where the nature of organisational problems within clients are barely structured and recognised (Creplet *et al.*, 2001; Kakabadse *et al.*, 2006). Such situations demand specialised knowledge and capabilities that can be provided by the management advisory firm. However, in the case of an SME management advisory firm, it

would be beneficial to establish synergies between people working in similar domains. Doing so would allow superior access to human resources. A number of features can be added to the collaborative working environment in order to derive maximum value, for example, collaborative decision making (Cardell, 2002; Mudambi and Helper, 1998); recognition of the need to actively manage multiple actors' interests (Boddy *et al.*, 1998) and equitable benefit sharing (Cox, 2001). To accommodate these different features that encompass collaboration, and therefore contribute towards generating added value, the term Value-Enhanced Collaborative Working (VECW) has been coined.

In its broadest terms VECW considers the varied perspectives and in doing so attempts to bring clarity to this 'modified' outlook. For example, some special features of this modified outlook to collaboration include greater commitment to problem-solving through agreed common goals, sharing of risks and rewards, faster and clearer communications between collaborators and flexibility of service. VECW enables consideration of collaborative working in this wider context. Considering the above, VECW is defined here as the collective work of two or more individuals, teams or organisations, undertaken with a strong commitment to enhance the value derived from a collaborative enterprise. It includes key concepts of partnering and alliancing, using technology driven tools as appropriate, and managing systematic social interactions in order to achieve a common understanding between collaborative teams.

In the context of this paper, a small management advisory firm is defined as a private firm, which offers professional services, acts as a change-agent in client organisations and provides advice, analysis, focus, guidance, mentoring, questioning, problem-solving or delivering tasks. Taking into consideration the importance of value enhancement within collaborative working, there is a need to understand value and values with respect to SMEs.

### **Value and Values in Collaborative Working**

Value is very subjective, as it is a matter of opinion, compared to cost which is a measure of the amount of money, time and resources to obtain a requirement. Also, value for a person can change constantly to meet the requirements and thus measuring value as a concept can be difficult (Shillito *et al.*, 1992; Park, 2000). Any attempt to provide a definitive description must be valid in many different contexts (Woodhead *et al.*, 2001). Although the concept of value can have many definitions, generally they are not divergent (Anderson *et al.*, 1993, Monroe, 1990; Gale, 1994; Woodhead, 2001). These definitions mainly address 'hard' attributes of values not the 'soft' attributes that Emmitt and Christofferson (2008) discuss. Value is related to a price or cost but other aspects such as utility, cultural significance and markets can also be relevant. In comparison, values are the morals and ideals, which are reflected in people's attitudes, behaviour and shaped through their social relations (Emmitt and Christofferson, 2008). The importance of values is that once it is internalised it becomes, consciously or subconsciously, a criteria for guiding one's beliefs (Bruno and Lay, 2008). Values exist in relation to the values held by others and are thus not absolute and are in constant transformation. Hence, agreement of an objective best 'value' for a group can differ from the individuals' perception of value.

A collaborative organisation should regard value as the end-goal of all projects and thus it is imperative to discuss and agree on the value parameters (Emmitt and Christofferson, 2008). These parameters are fundamental for achieving collaboration and therefore, stakeholder satisfaction. Hence, it is important that different stakeholders in this collaborative arrangement establish and use a shared "value" to "frame" a specific problem context for a



given project or to run a series of collaborative projects (Austin *et al.*, 2001; Emmitt and Christoffersen, 2008). Figure 1 helps in explaining how different stakeholders with different or similar values can work collaboratively towards a common goal and still achieve certain individual objectives. Here, Plane 1 at the bottom gives that “strategic context” for the collaboration between the stakeholders. The collaborative team determines a specific problem context for a given project within the above “strategic context” based on the stakeholders’ common goal and shared set of values (Lu *et al.*, 2007). The process of identifying this common goal effectively requires a dialogue between stakeholders to explore and confirm a set of values that form the basis of that project (common values), which is best carried out by face to face meetings (Emmitt and Christoffersen, 2008).

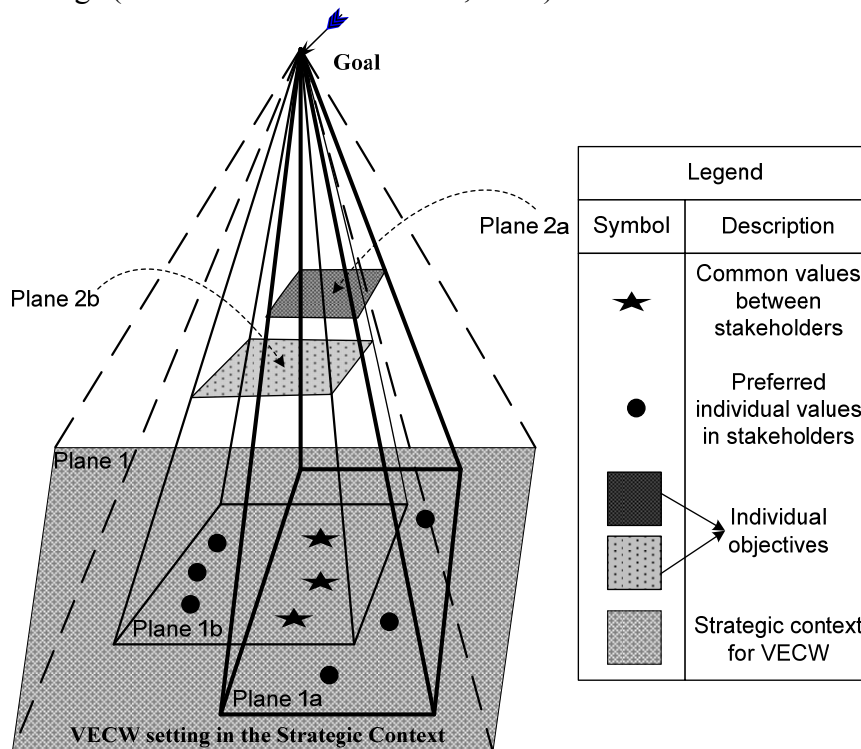

Figure 1: Arriving at Common Value in VECW for Different Stakeholders (Based on Lu *et al.*, 2007)

Different stakeholders bring different perspectives based on their expertise, experiences, backgrounds and objectives. Planes 1a and 1b are the preferred individual values related to the strategic context of the two stakeholders. Here a perspective is a particular viewpoint in which a stakeholder perceives a problem. According to Figure 1, these different perspectives are a result of the different values that the stakeholders hold due to their individual nature of work, or the individual objectives and aspirations (planes 2a and 2b in Figure 1) through the collaborative effort in the project. The stakeholders then need to dynamically co-construct each other’s contrasting/complementary perspectives to achieve a shared understanding of the project. This common understanding is the collective vision of the project.

A case study was conducted to examine the performance improvement through value enhanced collaborative working in a small management advisory firm identified as Firm A in this paper. This paper presents the findings of the case study that led to the development of the VECW framework.

### Research Methodology

The primary aim of the research was to derive performance improvements to the sponsoring company (a small management advisory firm) through VECW. For this purpose, a

case study of a small management advisory firm and its collaborating stakeholders is considered. Literature on collaborative working, concurrent engineering (CE) and value management (VM) philosophies have been critically reviewed to understand the gaps between the technology-driven tools that support collaborative working and the impact of human and social dynamics in the organisation.

The first stage involved a comprehensive review of literature on collaborative working and the role of value within a collaborative working environment. This led to a better understanding of collaborative working requirements in a small firm context and the barriers to derive value from collaborative working. Initially, exploratory observations helped to identify issues of collaborative working in Firm A. The selection of Firm A for the current research was based on its providing the right context and the willingness of its management to provide access for the required depth of analysis. The collaborating parties in Firm A's organisational setup are the Associates and Strategic Partners. Initial observations highlighted that in Firm A -:

- Limited business was being generated by collaborating parties;
- Limited financial/business value was being derived through collaboration; and
- There was poor communication between Firm A and its collaborators.

Following the exploratory observations, a detailed case study was undertaken to address the research problems being investigated. A qualitative approach (involving structured interviews and document analysis) was considered appropriate for the research since the research was exploratory in nature. The research sought to investigate the reasons for the issues highlighted in the initial observations of Firm A. The unit of analysis for this research was individuals involved in the collaborative arrangement either through Firm A (i.e. Directors or employees) or their collaborators (i.e. Associates and Strategic Partners), since they are a definable and observable unit.

As part of the case study, semi-structured interviews were conducted with different stakeholders to identify factors that affect collaborative working within Firm A. The interview questions were developed by asking questions broadly and then were narrowed by asking sub-questions. The interview sample consisted of stakeholder groups, including Firm A directors, clients and collaborators. The selection of the sample was based on a representation of both Firm A and their collaborators, and an outside view in terms of the collaborative performance from their clients. In all, six face-to-face interviews were conducted (two interviews each with Firm A directors, clients and collaborators). The interviews were helpful in understanding the existing collaborative business model.

The interviewees were encouraged to illustrate, through examples, the barriers of existing collaboration model and the underlying reasons behind it. For example, within the need for communication to ensure proper collaboration, questions were asked to find out what were the channels of communication between the different collaborators? How often they had face-to-face meetings and what were the protocols for following a prospective project lead? What were the advantages as well as issues with the current communication channels and protocols? Their views on collaboration (or a lack of it) and whether it affected their day-to-day working were considered to be of particular importance. The rationale behind the questionnaire was to establish a) the current collaboration practices between Firm A and its

stakeholders; b) barriers and enablers to collaboration between Firm A and its stakeholders; and c) information transparency and communication within the collaboration team.

Analysis was carried out thematically and the patterns of collaborative behaviour were built up within the transcript to enable development of a conceptual framework. The method adopted for synthesis of the case study data was thematic synthesis. Thematic synthesis was helpful to review the facilitators and barriers of collaboration within the SME services firm. It assisted in reviewing the appropriateness, intervention need and acceptability of the enhanced value through collaboration amongst the interviewees. The following section gives a description of the background of case study organisation as well as the case study analysis and findings.

## **VECW CASE STUDY**

### **Background of Case Study Organisation**

In order to investigate the key components and issues associated with collaborative working and the effect it has on enhancing (and deriving) value, a detailed case study of Firm A, a small management advisory firm within the UK, was conducted. The organisational structure of Firm A comprises of three directors and one employee. The directors have several years of experience in a wide range of industries such as construction, manufacturing, water engineering and service and utility sectors. Firm A collaborates with Strategic Partners to develop licensed proprietary management tools that are used to resolve and manage different collaboration related issues ranging from organisational alignment to partnering and change management. It works closely with a group of Associates who work collaboratively on different projects. In the context of Firm A, Strategic Partners are experts in particular fields and they provide new tools in that field, while Associates are the consultants working with Firm A collaboratively and providing their services. Firm A operates on a collaboration model where Associates, Strategic Partners and Directors share resources, expertise and knowledge to achieve business objectives. Figure 2 shows the collaboration environment within Firm A divided into an inner-core, a transient-core and an outer-core. Firm A directors and employees form the inner core of the collaboration environment. Associates and Strategic Partners are part of the transient and outer core as they are not directly involved in the management of Firm A's activities. However, if any of the Associates or Strategic Partners take an interest in further development of Intellectual Property (IP) or acquire projects for the collaboration environment then they are considered to be in the transient core, where they work closely with the inner-core Firm A directors. There is no clear demarcation between the transient and the outer core. However, an Associate or Strategic Partner can transcend this boundary by getting highly involved in one-off projects. The motivation for being in the transient-core is greater financial rewards and a chance to be part of the inner-core by taking up a director role for sustained business generating collaborative efforts.

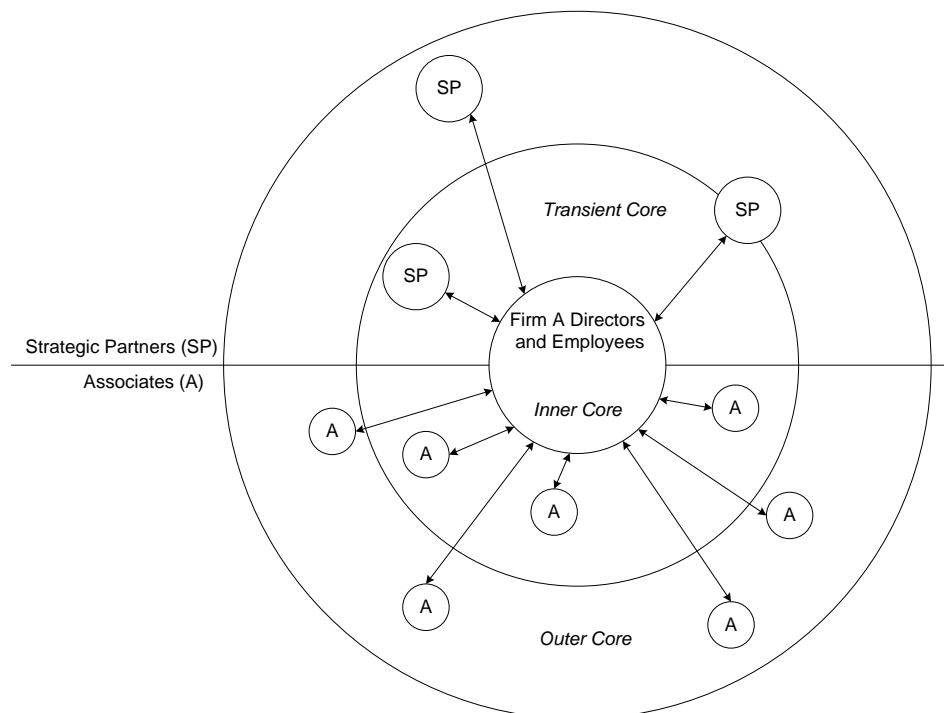

Figure 2: Business arrangement of Firm A

The business structure of Firm A is such that there is a core team of Directors, who collaborate with Associates on projects of varying sizes and budgets. The current structure does not require an Associate to have formalised agreements for collaboration. The strength of such a voluntary collaborative arrangement is that there is flexibility in terms of who to collaborate with. The downside, however, is that there is no binding requirement that necessitates Associates to collaborate or bring in new business. Such an arrangement or flexible structure has limitations, as neither Firm A Directors nor the Associates have guaranteed monetary incentives to continue collaboration in the future. To encourage long-term sustainability this needs to be considered.

A VECW framework has the potential to address some of the issues highlighted and in doing so inform other SME advisory firms with similar (VECW) business models. In short, the research investigates the impact of collaborative working strategies on Firm A where limited resources lead to a dependence on Associates for important business processes. To ground the framework, it was important to understand the existing attitudes towards collaboration in Firm A and its stakeholders. This was followed by identification of major issues that can be divided into themes to form the conceptual VECW framework. A case study approach was adopted: interviews were conducted with two Directors of Firm A, two Associates and two Clients.

### Case Study Analysis and Findings

The case study questions were divided into three parts, (1) Firm A's collaboration practices, (2) enablers and barriers to collaboration, and (3) information transparency within Firm A collaboration. Each interviewee was asked to describe their roles and responsibilities with respect to collaboration with Firm A (wherever possible, giving examples), typically ranging from winning projects through to the implementation of the project. The roles and responsibilities of the Associates in the collaboration (as envisaged by the Clients and Associates) were more at business level activities where, Associates provided Firm A with their services in implementing projects with Clients. However, in addition, Firm A Directors expected more strategic business generation by the Associates as part of this collaboration.

Increased incentives in terms of bonus payments were in place for the strategic work of Associates but were not clearly communicated to the Associates. There was a lack of shared vision and communication gap between the collaborating parties, indicating *people issues* in collaboration that needed attention.

Not all Associates were involved or even interested in collaborating at a strategic level to generate new business. They were quite content with offering their services at a business level, after the projects were won. These Associates formed the outer core of the collaborative working environment. However, Firm A directors failed to distinguish such groups from the inner or transient core group (as discussed in the background of the case study company) involved in strategic activities such as business generation. The analysis of these interviews thus highlighted *process issues* that fail to cover both these distinct groups of Associates. Firm A directors felt this might be the result of a lack of formal processes to identify the appropriate Associates for the collaboration. From Firm A's point of view, Associates should possess fundamental consultant skills such as experience, functional transferable skills and objectivity, among other things. Also, consistent with management literature (e.g. Kakabadse *et al.*, 2006) the consultants' responsibilities for managing Client expectations and strategic transfer of skills were considered real important. As far as the selection of Strategic Partners was concerned, it was based on the tools they developed and their potential use in projects that required those tools. Thus the selection process of Strategic Partners was clearly defined; however, there was no clear selection policy for Associates. Clearly, this is an area that needs attention.

Clients pointed out the visible barriers to the collaboration model of Firm A. They felt that at times Firm A Associates have 'digressing' agendas as compared with Firm A. One Client compared Firm A with similar Associate-based organisations and feels that these organisations are aligned to an idea and it is thus easy for a Client to understand them. According to the client, the challenge for Firm A is to create synergy among Associates that is evident to the Clients. As one Client pointed out "The business would get a boost when groups' intent is clear to the market." Since the literature is clear about the important role of personal client-consultant relationships for any consulting project success, it is important to give a clear message to the client (Kakabadse *et al.*, 2006 and Czerniawska, 2006). Hence, it is a *people issue* in terms of communicating the intent clearly to the market and a *process issue* to help the Associates understand what is to be communicated to market on behalf of Firm A collaboration.

In the final set of questions, all the case study participants were asked their views on information transparency. The Associates and Clients felt that there was adequate information transparency. However, a lack of knowledge of the tools available to Firm A and its stakeholders was a concern for the Associates. These tools are based on different philosophies of collaboration including strategy exploration, value frameworks, readiness diagnostics for collaboration, and cost management in multi-alliance projects. The Associates felt they needed training or workshops on the tools available with Firm A to understand their uses in different projects. This lack of understanding of the collective technical competency and know-how of different tools and techniques was a setback to the core business idea behind this collaboration expecting Associates to market the services of Firm A. Hence, there is an issue regarding the *tools* used by Firm A. This has led to inability of Associates to market Firm A collaboration technical competencies to prospective Clients.

In summary, the result of the case study analysis was the identification of a set of central themes that either enhance or hinder the performance of Firm A and its collaborators. The analysis found primarily three central themes: a) the process of collaborative working; b) information transparency and c) communication. Further analysis within each of these themes against the instances when Firm A and collaborators were attempting to win projects or work on existing projects yielded a set of findings. These findings revealed the different set of issues responsible for the current state of organisational collaboration prevailing within Firm A and its collaborators. An overall analysis of the case study thus revealed issues related to *people*, *processes* and *tools*, leading to the following consequences prevalent in the organisational collaboration between Firm A and its stakeholders:

- Associates and Strategic Partners have little incentive to generate new business for Firm A. Hence more incentives through process changes should generate more business leading to VECW over a sustained period.
- A diverse range of Associates do not share the same vision as the Firm A Directors. It was a direct reflection of the lack of communication between Firm A and collaborators, hence a gap in the people issues.
- A lack of understanding of the collective competency and know-how of tools. The tools ranged from strategic tools to cost management tools and from organisational alignment tools to implementation tools. It is important to identify the core competency generated through these different sets of tools within the collaborative environment.

The applicability of this case study should be wide across the industry base due to the similar issues faced by such SME organisations. Resource limitations, dependence on a limited number of staff for strategic as well as organisational tasks, inexperience to enter new markets and wider networking opportunities are common issues faced by SMEs involved in services. Hence, a case study such as provided in the current research would generate results that are useful over similar organisations in the context of collaborative working, its strategy and outcomes of the related issues. Consequently, this research would facilitate the development of policies for similar businesses in the wider construction industry.

By comparing and contrasting the findings of the literature review and the case study, it was possible to tease out the key components of a VECW, which subsequently led to the development of a conceptual VECW framework discussed in the following section. A conceptual framework is required here to address the issues identified in the interview findings and organise them to communicate them effectively. It is an overview of ideas and practices involved in VECW that will shape effective collaborative working in Firm A.

### **CONCEPTUAL VECW FRAMEWORK**

The conceptual framework forms part of working hypothesis prepared for VECW and it defines descriptive categories (factors) as stated by Shields (1998). The conceptual framework identifies sub-factors within these factors that need to be considered to improve the collaboration efforts of Firm A and Associates based on literature review and the case study interviews.

As mentioned in the previous section, the majority of collaboration issues could be divided into three major issues i.e. Processes, People and Tools. Researchers such as Prasad (1996), Austin *et al.* (2001) and Khalfan (2001) suggested similar factors to control the character of an organisation in their studies. Prasad's work was based on manufacturing organisations, while Austin *et al.* referred to design chains and Khalfan adopted a construction organisations' perspective. Table 1 below is a comparison of Prasad (1996) and Austin *et al.*'s. (2001) view of these factors.

Prasad concentrated on the organisational elements while Austin *et al.*'s analysis focused on how best to achieve these factors. Prasad's (1996) manufacturing organisations are different from the traditional engineering view as they have a more value-centric view; where instead of just providing a manufactured product they might even provide the subsequent service supporting those products to generate more value for the client. Austin *et al.*'s (2001) design chains are considered similar to management advisory firms as parallels exist between a design chain; where different people/organisation are involved in providing a service, which satisfies common objectives of the project. Hence, identification of the issues from the case study interviews and Prasad's (1996) classification of organisational elements to control the character of organisations helped in deducing the VECW framework into the three elements of Process, People and Tools. Austin *et al.* (2001) helps in identifying the routes to achieve these factors to facilitate VECW in Firm A.

Table 1: Factors Affecting Character of an Organisation (Prasad, 1996 & Austin *et al.*, 2001)

Factors affecting organisation	Prasad (1996)	Austin <i>et al.</i> (2001)
Processes	Consists of policy, practice and procedure to help in design of business, management, cultural, technical and operational processes.	Combined effectiveness of collaborating organisations is ensured by no duplication of processes.
People	Consists of the value system of an organisation and human factors such as cultural, social, training and intelligence.	It is the simple ability of people to work together.
Tools	Consists of the tools and technology available with the organisation.	The design processes are allocated based on the organisation's technical competency.

Literature (Das and Teng, 2000; Anand and Khanna, 2000; Hoffmann and Schaper-Rinkel, 2001; Belderbos *et al.*, 2004) suggests a wide array of factors responsible for collaboration such as the working environment, culture, the structure of collaboration, the process factors, the tools of collaboration, the technology, communication, and resources. However, most of these factors can be a sub-factor of people, tools or process factors. Since these are recognised by the literature and the issues in the current case study also recognise these factors, the current research sticks with these factors. The case study interviews highlighted issues within each of these factors in the context of Firm A and their work as a management advisory business. The factors are broad subjects in themselves and thus, further subdivision gave particular focus to the small management advisory business. Further subdivision of the factors was based on the challenges faced by the firm in the current situation.

## Process Factors

Firm A is a service organisation. Ideally for clarity of business activities carried by different roles, Firm A should have a process map that specifies a set of logically related activities and resources that yield a certain output. However, the case study analysis reflected that Firm A Directors, although recognising discrete processes for each stage of a project, lack a process map for the organisation. This has resulted in different collaborating stakeholders not conversant with their roles and responsibilities in a collaborative working environment.

A detailed process map forces the enterprise to look at how functions must co-operate in order to achieve collaboration among the stakeholders (Gibb *et al.*, 2006). Figure 3 below was developed to provide an ‘As Is’ process map at a high level of Firm A’s collaboration efforts to understand the important processes involved in Firm A collaboration. The processes identified here are based on the information provided by the case study interviews. It is evident that the processes are project-based (operational) rather than strategic in nature and there is no clarity on how to involve the stakeholders to derive value from it. It also has no consideration of the instances when there are no prospective projects available for Associates to sustain a collaborative relationship. The result being Associates have no real communication with Firm A’s directors.

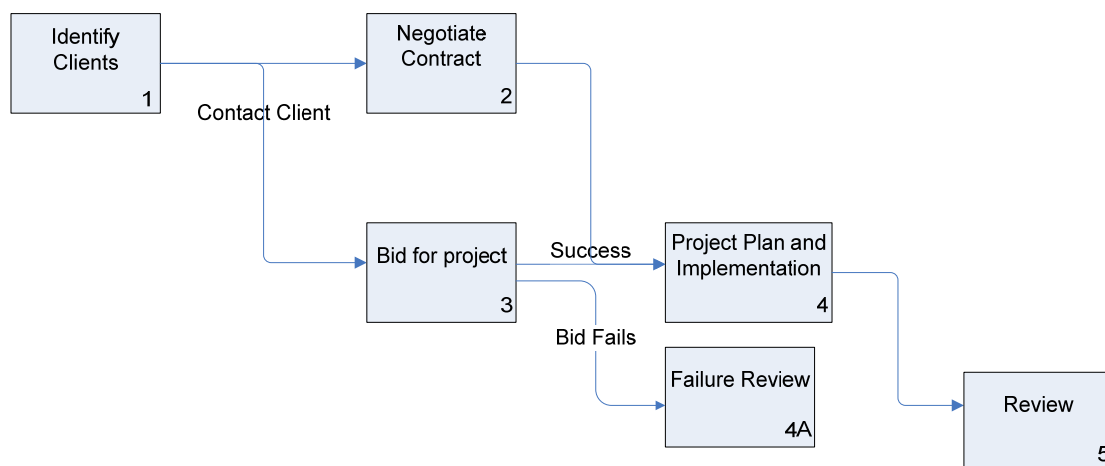

Figure 3: High level ‘As-Is’ processes in Firm A collaboration

An example of the project based processes involved in Firm A is project planning and implementation as shown in Figure 3. In this process, the project planning and implementation work starts once there is a success in the bidding process for a project. However, it leads to considerable time lags if the Associates involved in the project are not trained in the tools to be used for the implementation. Hence, it leads to precious time loss. Another issue is the lack of communication regarding the availability of Associates for particular projects which can lead to double booking of Associates. In order to address these issues, there needs to be a comprehensive process model in place to take care of the above described instances. This would be possible only if the processes designed are not project based.

Development of the detailed processes would result in an improved business model, where processes are in place to ensure that the relationship with Associates is sustained when



projects are not forthcoming for the Associates. A process map for this new method of working would reflect its 'To-be' processes. The 'To-be' process map will constitute all process activities as value added operations with a degree of flexibility and variability in terms of their repetitive nature (McAdam *et al.*, 2005). Thus, the important sub-processes of the process factor in VECW can consist of the following:

- Stakeholder Integration – consisting of developing strategic business processes e.g. selection of stakeholders, communication with stakeholders and positioning them in the overall process map;
- Detailed Process Mapping – Map the 'As-is' process at the sub-process levels to find all value generating process for this collaboration;
- Recommended Processes – consisting of the 'To-be' processes and ways of incorporating the 'to be' processes.

These sub-processes are identified in the conceptual framework for VECW (Figure 4).

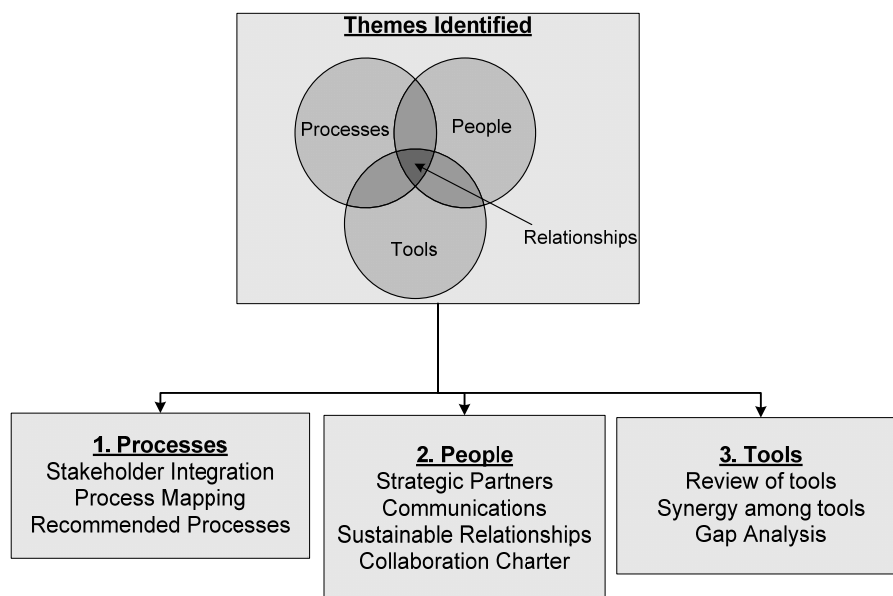

Figure 4: Framework for VECW

### People Factors

A key aspect of collaborative working is the ability of individuals to share knowledge. There are several factors that can influence knowledge sharing ranging from social and organisational to extremely personal (Coakes *et al.*, 2008). In the conceptual VECW framework, these factors are described as the people factors due to its individual nature. An important people factor in Firm A is the role of communication since most Associates and Strategic Partners are geographically dispersed. Another issue which was reflected in the case analysis interviews was the need to sustain long term relationships with the Associates. This would require a better understanding of the Associates' value system, the need for regular face-to-face interactions and most importantly participative decision making (Jackson, 1999; Lu *et al.*, 2007; Emmitt and Christoffersen, 2008).

In the current scenario, the communication of roles of Associates and Strategic Partners in running this collaboration is not well defined at the start of the relationship. A recommendation is to adopt a new type of partnership agreement between the stakeholders

that will include these people issues that are not covered in the existing partnership agreement. The current agreement of Firm A is prepared more with Yli-Renko *et al.*'s (2001) view of protecting oneself from opportunism, while another more sustainable and positive use can be creating and maintaining a long-term relationship between the parties (Frankel *et al.*, 1996). A Collaboration Charter can be this new flexible agreement that helps the stakeholders to create a long term sustainable relationship and achieve the overall objective of the collaboration. Here a Collaboration Charter can be defined as a written document generated for the formation of the collaboration that outlines the collaboration's distinctive character, values, goals, milestones and output. A thorough analysis of the existing agreement in the ongoing research will determine the essential inclusions within this charter and the significance of periodic review of the charter. It is acknowledged that the Collaboration Charter is one way of solving some of the communication issues but it needs to be followed with other efforts. Hence the important sub-processes of the people factor in VECW (see Figure 4) can consist of the following:

- Strategic Partners – a more detailed role descriptions for the Strategic Partners function within the collaborative arrangement.
- Communications – a comprehensive strategy to ensure clear communications with all the collaborating parties. This can be achieved by development of clear protocols and appropriate information distribution through the use of the wide area network.
- Sustainable Relationships – The goal of the development of any collaborative relationship should be an aim to provide circumstances for developing sustainable relationships over a sustained period of time.
- Collaboration Charter – Lastly, a new partnering agreement which covers contractual as well as all the above mentioned people issues.

### **Tools Factor**

A periodic review of collaborative tools available to Firm A helps to identify gaps in the portfolio of tools to sufficiently provide the type of business their clients expect. The case study interviews identified no formal process for selecting tools. The different tools available with Firm A are stand-alone with no obvious overlap or synergy. A desk study review of the tools concluded some of these tools were exploratory in nature, while some others were questionnaire-based or used a technology platform. These tools ranged from strategic explorations tools to cost management tools and from organisational alignment tools to implementation tools.

Porter (1985) discussed the inability of organisations to understand and implement different tools, when they fail to realise the synergy between these tools. Firm A is not a single-product entity and hence, synergy between the tools would help in the sharing of tangible and intangible resources as well as providing holistic view of the overall capacity to the client. The understanding of the synergy between the different tools available would result in compromise costs (Osegowitsch, 2001). The quality of a collaborative project team (Directors and Associates) may suffer as Associates are forced to divide their attention and training among several tools which leads to compromise costs. The conceptual VECW framework considers such costs by further development of synergies between these tools and help the collaboration in delivering better services to their clients. Consequently, the

important sub-processes of the tools factor in VECW (see Figure 4) can consist of the following:

- Review of Tools – a periodical review of the collaboration tools available at the organisation’s disposal will help identify any potential skills gaps..
- Synergy among tools – many tools are developed for different industries or are procured from different organisations leading to a wide variety of platforms on which they are based. However, it is important to have some synergy to use these tools either concurrently or one after another within a project.
- Gap analysis – based on the review of the tools and the existing market conditions or the type of clients from which an organisation is planning to win the projects. In addition, the relative investment of resources for the Associates to develop skills (e.g. a particular tool’s training) to plug a particular gap also needs to be ascertained.

### **Further Development**

The conceptual VECW framework recognises the diverse interests and expertise of the stakeholders (Associates and Strategic Partners). The People factor within this framework will ensure stakeholders understand the primary goal of the collaborative environment and work towards it by agreeing to common goals. Associates and Strategic Partners are essentially organised in a structured way through the Process factors to deal with potential disparity of power and/or resources for dealing with the issues at hand. The People and Process factors together give structure to sharing of risks and rewards, and enable faster and clearer communications while keeping flexibility of service among stakeholders. The Tools factor of the conceptual VECW framework will develop competencies of the different stakeholders and align strategically multiple stakeholder collaborations towards a primary goal. Lastly, due to the structured format of the conceptual framework, information transparency would improve among the stakeholders. Formalised feedbacks, joint Intellectual Property development, planning and explicit sharing of information help to enhance long term sustainable relationship of the stakeholders.

This paper established the conceptual structure to VECW based on the literature review and the case study of a small management advisory firm. The next step is to further develop the conceptual VECW framework into a comprehensive VECW framework. This would involve developing all the three factors in further detail and develop specific actions within each of the factors to ascertain robust development of the comprehensive framework. The comprehensive framework would furthermore help to create additional studies for the application of VECW to other SME management advisory firms.

### **Conclusions**

The motivation for collaboration within SMEs is to provide quick and flexible access to external resources. The research was based on the case study of the apparent failure of a particular SME management advisory firm to derive value from its collaborative model. The Firm A case study identified issues such as limited success to win new projects, lack of common vision among Associates and the firm Directors, lack of understanding of tools available to Associates through their alliance with Firm A and an inability to understand the collective competencies of each other. The collaboration is not generating much financial

value or enough business value in terms of networking and knowledge to the Associates to keep them actively engaged in the arrangement. The inability of the Associates to engage at a strategic and tactical level in this relationship, limits the core business aspirations of Firm A.

In order to solve these issues, an approach called Value-Enhanced Collaborative Working (VECW) was established in the context of a small management advisory firm and a conceptual VECW framework was proposed and discussed. The major components of this framework consist of process, people and tools factors. These factors were based on the literature review and case study findings. The framework gives a structured approach to agreeing common goals, sharing risks and rewards, and providing faster and clearer communications and information transparency between stakeholders.

The research method concentrates on the issues faced by Firm A. The nature of the case study research approach determines the high degree of internal validity; however, it limits the generalisability of the finding. The idea here is to formalise the concept of VECW through a case study with the perspective of the Firm under study, with factual accuracy and internal evaluation. Another research limitation is the reliability of respondents. For example the researcher needs to rely on the reasons given by the respondents relating to the issues of collaboration in the current arrangement. Hence, the researcher can simply present an interpretation of the issues and events related to them.

A wider impact of the research work on the industry can be determined from the fact that many SMEs involved in services have similar characteristics to the case study organisation. The need to rely on a collaborative working arrangement in the case study organisation is due to the dependence on a limited number of staff available to take additional tasks in Firm A, limited resources, inexperience to enter new sectors or clients, etc. All these are common in most service sector SMEs. Whilst the individual firm's circumstances may be unique, the context of collaborative working, strategy and outcomes of the related issues would be in general apparent in other businesses too and hence, the conclusion of the current work should facilitate the development of policies for similar businesses. Future research will establish specific actions to achieve the important sub-factors within each of the process, people and tools factors. The developed conceptual VECW framework has the potential to solve collaboration issues in any SME firm, but the conceptual framework is a guideline and it would require the constant supervision by senior management in the firm.

## References

- Anand, B. and Khanna, T. (2000), "Do firms learn to create value? The case of alliances", *Strategic Management Journal*, Vol. 21, pp. 295-315
- Anderson, J.C., Jain, D.C. and Chintagunta, P.K. (1993), "Customer value assessment in business markets: a state of practice study", *Journal of Business to Business Marketing*, Vol. 1, No 1, pp. 3-30
- Attaran, M., Attaran, S. (2002), "Collaborative computing technology: The hot new managing tool", *Team performance management*, Volume 8, Issue 1 /2, pp 13-20
- Austin, S., Baldwin, A., Hammond, J., Murray, M., Root, D., Thomson, D. and Thorpe, A. (2001), *Design Chains – A handbook for Integrated Collaborative Design*, Loughborough University
- Belderbos, R., Carree, M. and Lokshin, B. (2004), "Cooperative R&D and firm performance", *Research Policy*, Vol. 33, Issue 10, pp. 1477-1492

- Boddy, D., Cahill, C., Charles, M., Fraser-Kraus, H., Macbeth, D. (1998), "Success and failure in implementing supply chain partnering: an empirical study", *European Journal of Purchasing & Supply Management*, Vol. 4, pp. 143–151
- Bruno, L.F.C. and Lay, E.G.E. (2008), "Personal values and leadership effectiveness", *Journal of Business Research*, Volume 61, pp. 678-683
- Cardell, S. (2002), *Strategic Collaboration*, Hodder Arnold, London
- Coakes, E.W., Coakes, J.M. and Rosenberg, D. (2008), "Co-operative work practices and knowledge sharing issues: a comparison of viewpoints", *International Journal of Information Management*, Vol. 28, pp. 12-25
- Cox, A. (2001), "Understanding buyer and supplier power: a framework for procurement and supply competence", *The Journal of Supply Chain Management*, Vol. 37/2, pp. 8–15
- Creplet, F., Dupouet, O., Kern, F., Mehmanpazir, B. and Munier, F. (2001), "Consultants and experts in management consulting firms", *Research Policy*, Volume 30, pp. 1517-1535
- Czerniawska, F. (2006), "Consultant: Good, Consulting firm: Bad", *Consulting to Management*, Vol. 7, Issue 2, pp. 3-5.
- Das, T.K. and Teng, B-S. (2000), "A resource based theory of strategic alliances", *Journal of Management*, Vol. 26, Issue 1, pp. 31-61
- Department for Business Enterprises & Regulatory Reform (2007), [online] "National Statistics – Statistical Press Release", available at: <http://stats.berr.gov.uk/ed/sme/smestats2006-ukspr.pdf> (assessed 4th March, 2008).
- Drozdow, N. and Carroll, V.P. (1997), "Tools for strategy development in family firms", *Sloan Management Review*, pp. 75-88
- Emmitt, S and Christoffersen, A.K. (2008), "Collaboration and communication in the design chain: a value-based approach", in O'Brien, W.J., London, K.A., Vrijhoef, R. and Formoso, C.T. (Eds.), *Construction Supply Chain Management Handbook*, CRC Press, USA (Chapter 5) (in press)
- European Commission (2008), [online] "Policy Areas – SME definition", [http://ec.europa.eu/enterprise/enterprise\\_policy/sme\\_definition/index\\_en.htm](http://ec.europa.eu/enterprise/enterprise_policy/sme_definition/index_en.htm) (assessed 25th June, 2008).
- Frankel, R., Smitz Whipple, J., Frayer, D.J., (1996), 'Formal versus informal contracts: achieving alliance success', *International Journal of Physical Distribution and Logistics Management*, Vol. 26, Issue 3, pp. 47-63
- Gale, B.T. (1994), *Managing Customer Value*, Free Press, New York
- Gibb, F., Buchanan, S., Shah, S. (2006), 'An integrated approach to process and service management', *International Journal of Information Management*, Vol. 26, pp 44-58
- Hammond, J. H., Koubek R. J., Harvey C. M. (2001), "Distributed Collaboration for Engineering Design: A Review and Reappraisal", *Human Factors and Ergonomics in Manufacturing*, Vol. 11/1 pp. 35-52
- Hausman, A. (2005), "Innovativeness among small businesses: Theory and propositions for future research", *Industrial Marketing Management*, Vol. 34, pp. 773-782
- Hoffmann, W.H., Schaper-Rinkel, W. (2001), "Acquire or ally – A strategic framework for deciding between acquisition and collaboration", *Management International Review*, Volume 41/2, pp. 131-159
- Jackson, P.J. (1999), "Organisational change and virtual teams: Strategic and operational integration", *Information Systems Journal*, Vol. 9, pp. 313-332
- Kakabadse, N.K., Louchart, E. and Kakabadse, A. (2006), "Consultant's role: a qualitative inquiry from the consultant's perspective", *Journal of Management Development*, Vol. 25, Issue 5, pp. 416-500

Khalfan, M.M.A. (2001), 'Benchmarking and Readiness Assessment for Concurrent Engineering in Construction (BEACON)', PhD Thesis, Loughborough University, UK

Lu, S. C-Y., Elmaraghy, W., Schuh, G. and Wilhelm, R. (2007), "A scientific foundation of collaborative engineering", *Annals of the CIRP*, Vol. 56, pp. 605-634

Major, E.J. and Cordey-Hayes, M. (2000), "Engaging the business support network to give SMEs the benefit of Foresight", *Technovation*, Vol. 20, pp. 589-602

McAdam, R., Keogh, W., Galbraith, B. and Laurie, D. (2005), "Defining and improving technology transfer business and management processes in university innovation centres", *Technovation*, Vol. 25, pp. 1418-1429

Monroe, K.B. (1990), *Pricing: Making Profitable Decisions*, McGraw Hill, New York

Mudambi, R., Helper, S. (1998), "The 'close but adversarial' model of supplier relations in the US auto industry", *Strategic Management Journal*, Vol. 19, pp. 775-792

Osegowitsch, T. (2001), 'The Art and Science of Synergy: The Case of the Auto Industry', *Business Horizons*, March-April 2001

Park, R. (2000), *Value Engineering: A Plan for Invention*, St. Lucie Press, London

Prasad, B. (1996), *Concurrent Engineering Fundamentals – Vol 1*, Prentice Hall, New Jersey

Porter, M. (1985), *Competitive Advantage: Creating and Sustaining Superior Performance*, Free Press, New York

Shields, P.M. (1998), "Pragmatism as a Philosophy of Science: A Tool for Public Administration", available at <http://ecommons.txstate.edu/polsfacp/33> (assessed on 25th June, 2008)

Shillito, M.L., De Marle, D.J. (1992), *Value: Its Measurement, Design and Management*, John Wiley and Sons, New York

The Stationary Office, 2007, *Construction Statistics Annual*, p 45, TSO, London

Woodhead, R. and Downs, C. (2001), *Value Management – Improving Capabilities*, Thomas Telford, London

Yli-Renko, H., Sapienza, H., Hay, M., (2001), 'The role of contractual governance flexibility in realising the outcomes of key customer relationships', *Journal of Business Venturing*, Vol. 16, pp. 529-5

## **APPENDIX B – PAPER 2**

Gohil, U., Carrillo, P.C., Ruikar, K.D., Anumba, C., 2009, “Fostering Collaboration within an SME Services Organisation”, *International Journal of Knowledge, Culture and Change in Organisations*, Volume 9, Issue 4, pp 107-122

## **FOSTERING COLLABORATION WITHIN AN SME SERVICES ORGANISATION**

**U. Gohil<sup>1</sup>, P.M. Carrillo<sup>2</sup>, K.D. Ruikar<sup>3</sup>, C.J. Anumba<sup>4</sup>**

<sup>1,2,3</sup> CICE (Centre for Innovative and Collaborative Engineering), Department of Civil and Building Engineering, Loughborough University, UK

<sup>4</sup> The Pennsylvania State University, USA

**Abstract:** Literature suggests that it is important for the SMEs to develop collaboration with other organisations to develop capability and competence, and provide a complete service to the clients. The objective of this paper is to investigate the prospect of fostering collaboration within SME services organisations and the role of collaboration agreements. This paper describes how an SME Services Organisation developed a Collaboration Charter to use in lieu of their existing partnership agreement. The charter should help in developing sustainable partnerships and help in better communication within the collaborative network. It is envisaged that the outcome of this paper would help the collaborative network in putting forward the concerns and expectations of all parties involved in the collaboration. The Collaboration Charter should enable a system for regulating collaboration while retaining flexibility to effectively harness the differences among the different parties.

**Keywords:** Collaboration Charter, SME Collaboration, Communication, Sustainable Partnerships



## Introduction

Literature on collaboration provides numerous motivations for small and medium sized enterprises (SME) to collaborate with each other such as allowing collaborators to pool resources, exploiting complementarities and providing quick and flexible access to external resources (eg., Das and Teng, 2000; Belderbos *et al.*, 2004; Danilovic *et al.*, 2005). In view of the growing need for collaboration between different parties, especially within SME organisations, the issue of how to foster collaboration to generate value for SME organisations is an important question. The rationale behind selecting SME organisations are the complexities associated with collaboration among such organisations where there are fuzzy boundaries between individual collaboration and organisational collaborations. This is due to SME collaboration with project partners who can be single person business entity and hence, all the collaboration with them are more at an individual level although the actual collaboration is with a business.

Much research agrees on the need to collaborate, allow partners to pool their resources and exploit complementarities to achieve better capacity, capability and competence towards their work (Das and Teng, 2000; Fritsch and Lucas, 2001; Belderbos *et al.*, 2004). In terms of SMEs, it becomes more important to collaborate since they usually have limited resources, leading to overloading of multiple tasks and resulting in organisational inefficiency (Major *et al.*, 2000, Hoffmann *et al.*, 2001). Recently there has been a significant rise in organisations providing professional services where projects are combined with products manufacture and provision of services after sales (Winter *et al.*, 2006).

The professional service industry has a more value-centric view of providing a service to create value and give benefit to different stakeholder groups (Levene, 2002; Brady *et al.*, 2005). SME organisations such as small management consultancies thus need to rely on collaboration among similar small organisations/individuals with complementary resources to attain a competitive advantage. A common predicament of development of such collaboration is the mechanism to foster a sustainable collaboration. A structure of the people/businesses consisting of a system organised by a characteristic pattern of relationships. The current research addresses this topic.

The objective of this paper is to investigate the prospect of fostering collaboration within SME services organisations and the role of collaboration agreements. A case study organisation is used. The organisation has high dependence on third parties to provide strategic and operational resource. The paper discusses how to help generate an active participation of such parties to get steady business/projects inflow and develop joint Intellectual Property. However this active participation has some challenges before it becomes second nature in the collaborative arrangement. The partnership arrangement between the collaborating parties are based on a agreement which is contractual in nature. The components of the agreement need to be consisting of components that help achieve the strategic aim of collaboration to provide steady business and develop skills, whilst giving all the collaborating parties enough room to conduct their own businesses.

The collaborating parties tend to have a diversity of views requiring clear and open communication as they belong to different management and work backgrounds. Another barrier to such collaboration is the development of trust to engage in collaboration. Lastly, commitment from all the collaborating parties is vital for sustainable results. Hence, the partnership agreement necessitate the need to enhance communication, trust and commitment

between the collaborating parties. It is a lengthy process that needs to be initiated by proposing some 'ground rules' that govern the collaboration. This paper proposes a collaboration charter (a type of partnership agreement) as an instrument to commence trust as well as commitment generation and help foster collaboration in SME organisation.

This paper focuses on the collaboration of SME organisations. A literature review on the components of the partnership agreement and the review of important facilitators of long term sustainable collaboration is followed by a brief organisational context for the case study organisation. A research method is discussed along with data collection and data analysis. The analysis of existing partnership agreement within the case study organisation results in identifying issues with the current arrangement. Eventually, there is a discussion of proposed Collaboration Charter with concluding comments.

### **Components of Partnership Agreements – A literature review**

A partnership agreement is a voluntary contract between parties to share their capital, skills and technologies, including Intellectual Property (IP), with the understanding of sharing of profits/losses between partners. However, these agreements or contracts have other purposes. Partnership agreements generally are prepared in view of protecting oneself from opportunism (Yli-Renko *et al.*, 2001) although another more sustainable and positive use can be creating and maintaining a long-term relationship between the parties (Frankel *et al.*, 1996). The discussions leading to the agreement should help perceive issues that might cause problems later on and thus agreement signing should reduce costs and risks. For example in services organisation, IP rights have become critical assets and dialogues on the ownership of these IPs form an important part of partnership agreements (Blomqvist *et al.*, 2005). However, given human bounded rationality specifically in long-term agreements, the uncertainties arising in longer period of time lead to incomplete agreements (Hart and Moore, 1999; Maskin and Tirole, 1999). Hence, a collaboration requires an agreement that is dependent on extensive commitments over a sufficiently long period of time. The agreement needs to be more complex in terms of creating contracts to enable better understanding but can still provide required flexibility to the stakeholders (Rousseau, 1995).

In addition to the hard and functional (e.g. legal framework, financial, operational) aspects of collaboration, a good partnership agreement should cover the soft side of management referring to the development and management of relationship capital (Cullen *et al.*, 2000). Researchers such as Burt (1997), Hosmer (1995) and Rousseau *et al.* (1998) consider trust and commitment as the major aspects of relationship capital that should help in facilitating long term sustainable relationships. Hence, in addition to partnership contracts people and organisations need to build up trust for considerable savings in time and effort required in agreeing and executing contracts, while commitment towards each other should ensure a long lasting collaboration.

#### **Trust**

Trust becomes more important with SME organisations, that might not want to rely on a contracting culture and work is carried out informally (Blomqvist *et al.*, 2005). It should play an important role in the development of long-term sustainable relationships because short-term inequities are inevitable in a relationship. Here trust can be defined as having sufficient confidence in the organisation and its Associates' capability and goodwill to commit valuable resources, such as finance and IP, to collaborate with that partner, despite

the risk and vulnerability that both parties may take advantage of (Child, 2001, Blomqvist *et al.*, 2005).

Nguyen and Rose (2008) provide three antecedents of trust – contextual factors, past experiences and individual attributes. Contextual factors consist of formal and informal institutional frameworks (Child, 2001; Nguyen and Rose, 2008). The formal dimension includes political rules, judicial decisions and economic contracts as covered in most partnership agreements. The informal dimension includes socially sanctioned norms of behaviour, which are embedded in cultural values and ideology. In the second category of trust antecedent, a partner feels comfortable if there is a history of positive experiences with the other parties (Doney and Cannon, 1997; Nguyen and Rose, 2008). Finally, individual attributes of the partners with high propensity towards trust and bonding help further development of trust.

Child (2001) takes another view to describe similar interactions by dividing trust into three main types: trust based on calculation; trust based on mutual understanding and trust based on bonding. If the collaborative relationship is based on the calculation of the likely outcomes relative to the cost and risk of maintaining the relationship, then the trust is based on calculation. Mostly business relationships in an organisation begins with such transactions with new Associates. Trust based on mutual understanding develops as the capability to do what is agreed as well as the intention to do so is demonstrated over a period of time. This type of trust results in the development of a relationship which eventually relies more on understanding and less on the formal contracts. Hence, trust based on mutual understanding is heavily reliant on the two trust antecedents - past experiences and individual attributes of the partners. Lastly, trust is developed based on mutual bonding achieved by sharing common values over a long period of time during which the collaborating parties meet regularly with each other on a personal basis. Any organisation should aspire to develop this level of trust through constant collaborative work. In retrospect, Nguyen and Rose (2008) combined their antecedents with each other to form the different types of trust described by Child (2001) as evident from Figure 1. In the figure, arrows suggest how different antecedents come together to generate different types of trust.

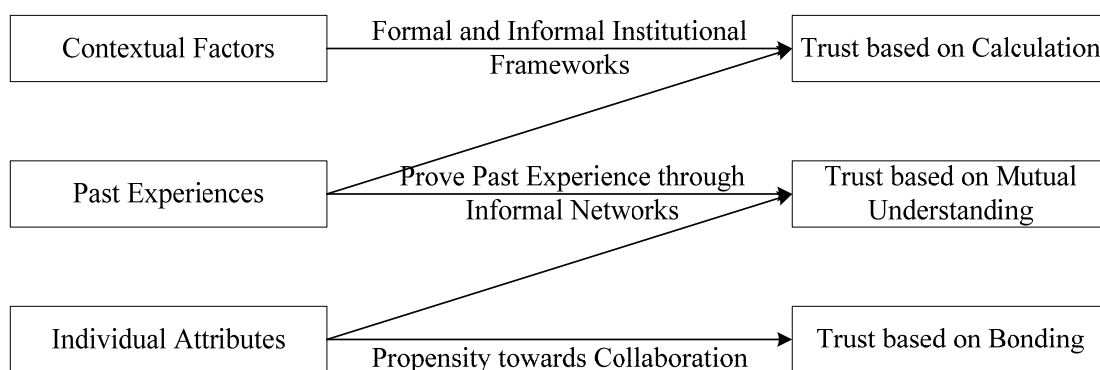

Figure 1: Dependence of different antecedents of trust on types of trust

The creation of the above mentioned types of trust in any organisation would require a sustained effort over a long duration. Hence, any agreement signed between the collaborating parties should have characteristics that help cultivate trust within the relationship.

## **Commitment**

Commitment in a collaborative arrangement is concerned with the partner's likeability of the other partner and intention to continue with the relationship (Cullen *et al.*, 2000). A unilateral and voluntary commitment of a partner should act as an incentive for other partners in the collaboration to cooperate and get higher business or financial value for all partners. SME organisation relies on this commitment since all its strategic activities are highly dependent on collaborating Associates due to lack of resources at times.

Wu *et al.* (2006) argue that commitment can be divided into two types. Transactional commitment, in terms of resources, would result in an effective way to reduce opportunism and enhance the value of the collaboration while relational-specific commitment enables firm to realise the importance of giving extra effort to make the collaboration work and a willingness to go beyond mere contractual obligations (Wu *et al.*, 2006). Investing time in preparing bids for a collaborating organisation's projects is a typical example of transactional commitment of Associates. Cullen *et al.* (2000) divide commitment similarly into two types and they share similarity with Wu's commitment types, where transactional commitment is referred to as the calculative commitment while the relational commitment is referred to as attitudinal commitment.

Transactional commitment involves intensive levels of business interactions with high levels of information sharing and knowledge transfer happening between the collaborators (Uzzi, 1997; Cullen *et al.*, 2000; Nguyen and Rose, 2008). Sharing information and knowledge imbedded within a collaborative setup would result in a better understanding of each other's needs, capability and ultimately willingness to collaborate thus signalling transactional commitment and facilitate reciprocal confidence.

As the collaboration progresses, there is a chance of a 'hard' financial or technological issue or interpersonal frictions come into play (Child, 2001). Relational commitment developed over a period of time should help in resolving potential conflict-like situations since it promotes a mutual win-win outlook. Development of relational commitment would require regular and frequent face-to-face meetings with the collaborating partners, to know if everyone shares the same vision and develop a personal relationship which ensures a relationship above contractual commitment. The face-to-face meetings should help in avoiding any perturbing surprises that may arise from miscommunication of letters, emails, etc.

Diversity in the workforce is an important component for any organisation. Segers *et al.* (2008) analysis suggest that older people are less motivated to follow training and develop themselves further, which is essential in any SME organisation, while acknowledging their need as the experienced members of the Firm. If an organisation has many Associates nearing retirement age, external motivators such as money and status would lose their motivational powers and hence, these Associates might not be highly motivated to find new business.

The literature review needs to be put under the consideration of the case study organisation. Hence a proper context of the organisation would help identify the need to foster collaboration within the case study organisation.

### Firm A context

There has been an extensive amount of research on collaboration among big organisations specially in the manufacturing field carried out (Das and Teng, 2000; Belderbos *et al.*). Hence, the current work wants to cover the SME services firms not included in most previous research works. Consequently, for the purpose of this project, an SME services organisation was preferred as the case study organisation. To maintain anonymity, this organisation is here referred to as Firm A. Firm A is a management and advisory business, run by experienced practitioners in the fields of Strategy Formulation, Organisational Alignment, Partnering/Alliancing and Implementation. It is a small organisation of three directors and one part time employee and hence, relies on Associates for strategic business development and sharing of critical resources. Here Associates are other management businesses (individuals or small firms).

Firm A has a collaborative arrangement with Associates and Strategic Partners. In the context of Firm A, Associates are the consultants that share resources and work collaboratively while Strategic Partners are the experts of a particular field providing new tools in their fields. Figure 2 shows the collaboration environment within Firm A divided into inner-core, transient-core and outer-core. Firm A directors and employees form the inner core of the collaboration environment. Associates and Strategic Partners are part of the external core; they are involved in joint working with Firm A as and when required. However, if any of the Associates or Strategic Partners take an interest in further development of IP or win projects for the collaboration environment then they are considered to be in the transient core, where they work closely with the inner-core Firm A directors. The motivation for being in the transient-core should be greater financial rewards and a chance to be part of the inner-core by taking up a directorial role for sustained business generating collaborative efforts.

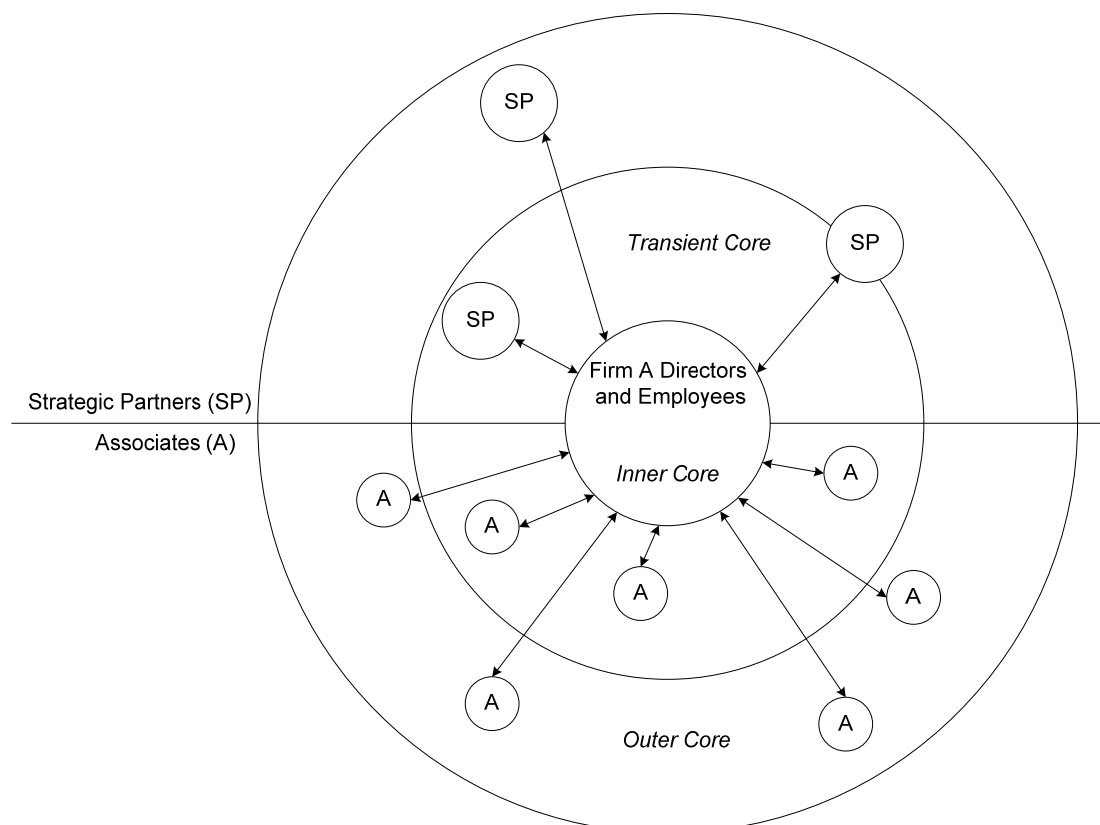

Figure 2: Business arrangement of Firm A

The business arrangement within Firm A was intended to induce a sustainable collaboration between Firm A Directors, Associates and Strategic Partners. However, on further investigation, it was evident that Associates considered the need for improved communication of their expectations when joining this collaboration. Hence a major issue with the current organisational setting is the systematic inclusion of new Associates in this collaborative environment. A precise and standardised approach to this inclusion will aid in development of relationships and foster collaboration in this environment over a sustained period of time. A well written document on this standard approach of starting and maintaining collaboration has the potential to be the agreement required for long term sustainable collaborative working in Firm A. This agreement should complement other factors like processes and tools used for collaborative working within Firm A eventually resulting in making the framework of collaborative working more robust and rigorous.

### **Method**

The purpose of this study was to investigate the prospect of fostering collaboration through the use of collaboration agreements. For the purpose of the study, literature was drawn upon from collaboration literature (eg. Das and Teng, 2000; Belderbos *et al.*, 2004; Danilovic *et al.*, 2005), partnering literature (eg., Blomqvist *et al.*, 2005), partnership agreements and contracts literature (eg., Frankel *et al.*, 1996; Yli-Renko *et al.*, 2001) as well as trust and commitment literature (eg., Cullen *et al.*, 2000; Child, 2001). To address the issues of fostering collaboration, an in-depth case study of Firm A (a service SME) was carried out.

The case study method of research was employed to provide a systematic way of looking at the events resulting in collaboration in an SME services firm and get an in-depth, longitudinal examination of fostering collaboration with the help of collaboration agreements. The level of analysis within this case study is not differentiated at organisational or individual level, although there is an appreciation that individual values play a part in the perception of the collaboration along with the organisational culture. Individuals collaborate in the current case study with different individuals to form project teams to achieve the business objectives. Next subsections give details of data collection and data analysis.

### **Data Collection**

The current practice of Firm A is to sign a partnership agreement with new Associates before embarking on any work with them. To understand the current agreement, a questionnaire was developed. The objective of this questionnaire was to find out if the current partnership agreement aided the process of fostering collaboration between Firm A and its Associates. If not, then what were the barriers to collaboration and what sort of changes in the existing agreement should help overcome these barriers. The questionnaire was sent to all the current Firm A Associates. Themes within the questionnaire were broadly divided into four parts consisting of: a) personal details of the Associates including their core competencies and industry experience; b) issues and expectations of the partnership agreements; c) details of different projects carried out and knowledge of Associates regarding Firm A technology; and d) communication within the collaboration. In total twenty two Associates were contacted by email and the response rate was around 70% (sixteen responses).

### **Data Analysis**

The analysis of the questionnaire responses highlighted issues that hinder the collaboration within Firm A. The responses identified motivations of Associates to work with Firm A. A new type of agreement referred to as a Collaboration Charter was produced to

cover these issues and promote a sustainable development of the relationships between Firm A and its Associates. This Collaboration Charter was then presented to the Firm A directors. The appraisal of the charter was carried out by evaluating it with the existing and prospective Associates through a strategic workshop. The workshop was a platform for Firm A to introduce their organisation as well as its values and philosophy. It was followed by a discussion on the prospective projects that Firm A would like to bid for in the near future. The Collaboration Charter was introduced as a relationship building process that would clearly communicate the expectations of the collaborating parties before they explored possible business opportunities. Discussion on the new charter was followed by responding a follow-up questionnaire to help complete the evaluation. The next section describes the existing partnership agreement in further detail based on the analysis. It is then followed by the proposed collaboration charter and conclusions.

### **Existing Partnership Agreement – A Case Study**

The existing partnership agreement was a legal document which formally started the collaboration between Firm A and the Associates. However it did not aid in ensuring ongoing participation of Associates for finding new business/projects, developing joint IP and achieving strategic aims of collaboration. The questionnaire responses helped in identifying the issues with the highly contractual current partnership agreement. The analysis of the questionnaire helped prioritise the different issues that hinder collaboration within Firm A and motivations of the Associates as well as Firm A to work together.

#### **Associate Background**

All twenty two Associates of Firm A were sent questionnaires to determine their work and age profile, their views on the current partnership agreement, the collaboration's business practices, communication networks and channels within the collaboration. A seventy percent (sixteen responses) response rate was achieved. However, on further investigation, it was concluded that some Associates had not been contributing to the network for a long time and had since lost interest in collaborating with Firm A. One Associate took the questionnaire response as an opportunity to communicate her intention of not continuing in the collaborating relationship, since there were no value added benefits being incurred to her business. The Associates' responses outlined the issues related to lack of initiatives to develop trust and commitment with new Associates or sustain it through regular formal and informal communication.

The age profile of the Associates shows an interesting characteristic of Firm A. Figure 3 indicates most Associates are approaching retirement age. Segers *et al.* (2008) clearly suggest that Associates might not seek an active participation in the collaboration since, the motivation to work decreases with age. Whilst Firm A prides itself on its vast experience base, it can be a dangerous predicament if they want to just carry out projects won by Firm A and don't want to actively try and get more business. The current age profile might not be a good indication of long term sustainable partnership and hence, Firm A might want to look for a better age distribution among Associates.

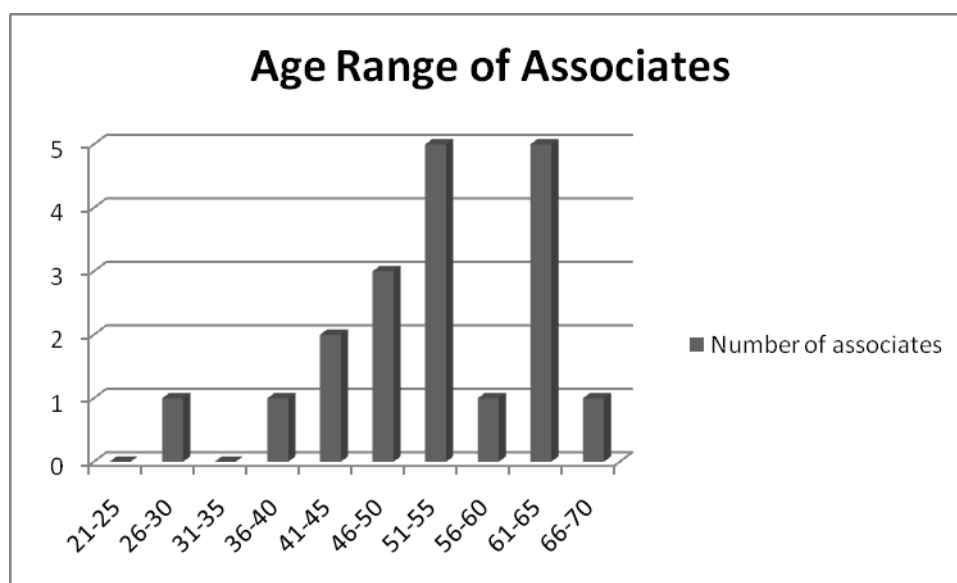

Figure 3: Age range for Firm A Associates

### Motivations behind collaboration

According to the questionnaire responses, the top motivators of entering into collaboration with Firm A for Associates were as follows:-

- 1) Increased core competency of the Associates through joint development of IP as well as training with Firm A (40%);
- 2) Increased area coverage geographically and chance to work with Associates in a wide range of industry sectors (32%);
- 3) Increased monetary as well as business benefits due to higher project availability (20%); and
- 4) Increased skill set development through training and networking (8%).

The motivations of different Associates to collaborate range from highly transactional to highly relational goals. On one end of the spectrum are Associates who are part of this collaboration just to acquire increased business opportunities. Whilst on the other end are Associates who want to be part of the network since they find Firm A directors to be very receptive, open in communications and people with high integrity and benevolence. They also find the current collaboration as a way to build up value for their business increase networking opportunities. Both these types of Associates are important for Firm A since Associates with transactional goals help build calculation trust within the collaboration while Associates with relational goals build trust based on mutual understanding. Calculation trust sustains short term collaboration while relational trust forms basis for long term collaboration. Over time and with sustained collaboration, both these types of Associates would build trust based on bonding.

### Communication within the collaborative arrangement

The breakdown of communication is a major issue for Firm A's collaboration activities. This can be divided into two distinct parts of networking failure and Associate reluctance to make use of intranet facilities. In the past year, there has been no effort by Firm A or its directors to contact the majority of its Associates, to the extent that Firm A was unaware of the retirement of one of their Associates. Firm A was unable to conduct any regular events for Associates. As discussed in section 4.2, many Associates see a



collaboration with Firm A as a means of increasing their skill-sets as well as core competencies. The Associates do not see value generated out of this collaboration because no formal training workshops to increase the core competencies were organised by Firm A. This has resulted in the failure of Firm A to build an active network of Associates and a lack of relational commitment (Cullen *et al.*, 2000). Firm A has an intranet platform for to share collaboration information, prospective projects, successful case studies and client contacts with appropriate levels of access for different Associates. Firm A shows high levels of such information sharing through the intranet facilities. However, Firm A has not always been able to encourage Associates to share similar information on the intranet.

### **Transactional language of the agreement**

The existing partnership agreement begins with the sentence '*This agreement does not establish the Associate as an employee of Firm A. The Associate shall at all times be responsible for his/her own taxation and social security payments in accordance with prevailing legislation.*' It is a good example of how intentions of building a good relational agreement have gone wrong right from the start. The signing of such agreements are supposed to be the first step towards building a long term relationship so care must be taken to avoid sounding protectionist in the agreement (Rousseau, 1998). Although the researcher acknowledges the legal importance of such statements, it is important to understand where these statements are placed within the agreement.

Any collaboration requires regular reviews to identify any potential conflicts or change in the overall aims and goals of the collaborating parties. However, Firm A does not have any periodic reviews of their partnership agreements. According to Firm A directors, the partnership agreement was never intended only as a legislative document, hence, the document seems unable to fulfil its original goal. Based on this analysis the major issues of the existing agreement can be summarised as follows:

- Lack of communication of Firm A's values, mission and goals before entering any agreement;
- Lack of a joint goal setting between Firm A and new Associates;
- Lack of effective communication of reward structure to develop calculation trust;
- Lack of emphasis on the 'soft' issues of collaboration such as building trust and commitment;
- Lack of communication of motivations such as building core competencies through training and development of networks to join the collaboration to generate trust based on mutual understanding;
- Lack of communication of commitment; and
- Lack of encouragement to share sensitive information within the collaboration while signing confidentiality undertakings for the background and foreground IP generated through collaboration;

### **Proposed Collaboration Charter**

The identification of the issues in the existing partnership agreement reflects the need for a new approach towards starting a collaborative relationship in Firm A. This new approach can be encouraged by a formation of a new agreement to start relationships with Associates. The new agreement is called a Collaboration Charter to reflect the importance of the 'soft' issues that the Firm A collaboration has failed to capture in its previous agreement.

The purpose of this Charter is three fold. At the start of a new relationship, it should determine the goals, expectations and motivations of both Firm A as well as the Associates. In addition, it should provide a foundation to ensure development of trust and commitment within the collaborating parties and lastly, it should form the basis for periodic reviews. It is clear that Firm A requires an agreement which serves both as a legislative contract as well as a psychological contract (Rousseau, 1998). According to Ruuska *et al.* (2008), the charter can include

- Collaboration's mission and purpose;
- Values and assumptions;
- Vision;
- Roles and contributions,
- Policies (competition, conflicts of interest, financial relationships); and
- Norms (participation, decision-making, communication, conflict, meetings), etc.

The response to the questionnaire helped in identifying the expectations of Firm A as well as the Associates from this relationship. Based on the literature and issues identified in the existing partnership agreement, the proposed Collaboration Charter includes the following sections:

- Firm A values and ethos;
- Vision and Mission;
- Communication aspects of collaboration;
- Sustainable relationship development; and
- Legal agreement

The charter emphasises Firm A's collaboration process protocol and open communications, consequently outlining the formal as well as informal aspects of contextual factors for creating trust within the collaboration. Within open communications, the document prescribes regular use of Firm A's intranet facilities and generation of periodic newsletters. In return, Associates are expected to contribute regularly to these newsletters. Such contributions should lead to the development of individual attributes of other Associates through open communications by writing articles in newsletters and build trust. It is anticipated that the current measures will ensure fostering of Nguyen and Rose's (2008) calculation trust, trust based on mutual understanding and trust based on bonding.

The new charter prominently promotes training and development of the skill-sets and competencies of Associates through regular workshops and training modules to encourage commitment as advised by Cullen *et al.* (2000) and Wu *et al.*'s (2006). Constant individual development is an attraction to create business value as evident from the questionnaire analysis. Lastly, a reward structure specifying the bonus system based on efforts put forward to market and tender for the collaboration, within the collaboration charter, provides financial incentive for extra effort. To acknowledge the dynamic and time dependent nature of aims and goals that Associates might have within the collaboration, periodic reviews are suggested after every two years. This is a chance to voice any conflict situations or concerns and review if any changes are required in the charter to better reflect the collaboration environment.

### Evaluation of proposed Collaboration Charter

The Collaboration Charter was evaluated with Associates to ascertain its usefulness in fostering better collaboration. The evaluation was carried out through a strategic workshop. Three prospective Associates and two long-standing Associates were invited to join this workshop. The Charter was introduced in this workshop and the workshop participants were requested to complete a questionnaire at the end. This questionnaire asked participants to identify aims of the collaboration charter and enquired if the aims were satisfied by this charter. It also discussed if the charter was sufficiently flexible to encourage motivation for collaboration among partners, a good mechanism to avoid conflicts and whether it could be used as a performance review document at regular intervals.

The Associates found the Collaboration Charter much more open and welcoming to the new Associates with its relational approach. They felt this Charter was more explicit in declaring Firm A's aims, aspirations and approach towards the collaboration. As one Associate pointed out, the charter provides a sound basis for 'ground rules of collaboration'. Table 1 below outlines the major differences between the old partnership agreement and the new Collaboration Charter along with the literature that supports the changes.

Table 1: Comparison of old partnership agreement and the proposed collaboration charter

Old Agreement	Literature support	New Charter
1. No introduction of Firm A, its values, vision and mission.	Importance of communication for building contextual factors of trust (Nguyen <i>et al.</i> , 2008) and commitment (Wu <i>et al.</i> , 2006)	The charter starts with an introduction of Firm A and its vision and mission.
2. Lack of joint goal setting.	Building psychological contract with Associates (Rousseau, 1998)	Importance of joint goal setting at the start of the relationship.
3. Lack of documentation of arranging networking events and development of core competencies.	Commitment towards collaboration (Cullen <i>et al.</i> , 2000; Wu <i>et al.</i> , 2006) and development of trust based on mutual understanding (Nguyen <i>et al.</i> , 2008)	An assurance to arrange regular networking events and training workshops in return for active participation from Associates and help in conducting these events.
4. Lack of reward structure for finding business.	Calculation trust development (Child, 2001) and age related motivations (Segers <i>et al.</i> , 2008)	A detailed reward structure to encourage prospective project seeking.
5. Lack of a process to regularly review the agreement as well as collaboration.	Avoiding conflictual situations (Child, 2001)	Annual review of the charter as a requirement to justify collaboration.

### Applicability to other organisations

As this is a study based on the issues faced by a particular firm, it is not without its limitations. Due to the nature of the study (case study), the results cannot be generalised to other similar SMEs or other SMEs in other contexts without some further research. The study

does not take into effect the consequences of working with Associates that might not be from the same country or culture and hence have different work culture or values. Nevertheless, the study is helpful in catalysing the relationship development between Firm A and its Associates. However, this work should be considered as a part of a wider portfolio of continued improvements for organisations to do collaborative working that will require persistent management support. It should work for other organisations as long as it is understood in the context of the overall general advantages and the Collaboration Charter takes into consideration changes related to particular variables of the collaboration culture among the organisations. These variables can consist of anything ranging from work culture to organisational arrangement and from communication protocols to ways of joint goal setting.

### **Conclusion**

The growing need of SME organisations to collaborate these days have ensured a need to facilitate means to foster these relationships as well as sustain it. Hence, it is a vital area of study within the collaboration research specially when it deals with collaboration of SME services organisations. The work in this paper is based on the collaboration arrangement of a small management consultancy that relies on its Associates for strategic business development and sharing of critical resources. The research question in this paper is to explore the role of collaboration agreements in fostering collaboration among SME services organisation and its Associates.

The method adopted for this research an in-depth case study. Primary data collection was carried out through thematic questionnaire responses of Associates, highlighting the Associate profiles as well as their motivations to collaborate with Firm A. The responses were further analysed to identify issues with the current partnership agreement and discuss components of a new collaboration charter that need to be considered for a long lasting collaboration. The charter components highlighted were theoretically grounded through literature study and empirically tested by conducting an evaluation workshop with Associates, prospective Associates and Firm A Directors.

The current work was successful in developing the first steps towards promoting collaboration between Firm A and Associates by providing a mechanism to foster the development of trust and commitment. The charter should help to develop a sustainable collaboration environment between the partners. Firm A as well as its Associates need to follow the charter with further practical action to sustain communication and the development of skills and core competencies. Periodic reviews will ensure the goals of collaboration between partners are aligned periodically and solve any conflict situations that may arise. Hence, the main managerial implications can be summarised in the following three points. Firstly, the charter achieved the first step towards understanding the collaborating parties' perceptions and goals of collaboration with Firm A. Secondly, the focus of the collaboration charter is on stimulating open communications and sharing of information, training and development of core competencies and conducting activities that ensure the mutual interdependence of the partners increase. Lastly, the collaboration charter emphasises that collaboration might work but it will require hard work from all concerned parties.

The paper has managed to achieve its objective by providing a critique on the existing partnership agreement and proposing a Collaboration Charter based on the related literature review and the requirements of a 'hard' legal document that can also be used in addition as a 'soft' document to develop collaboration. This Collaboration Charter has the potential to

commence a collaboration that is long standing and sustainable. Further research on the evaluation of the new Collaboration Charter over a period of an year should help improve collaboration.

## References

- Belderbos, R., Carree, M., Diederer, B., Lokshin, B., Veugelers, R., (2004), 'Heterogeneity in R&D co-operation strategies', *International Journal of Industrial Organization*, Vol. 22, pp 1237–1263
- Blomqvist, K., Hurmelinna, P., Seppanen, R., (2005), 'Playing the collaboration game right – balancing trust and contracting', *Technovation*, Vol. 25, pp. 497-504
- Brady, T., Davies, A., Gann, D. (2005), 'Creating value by delivering integrated solutions', *International Journal of Project Management*, Vol. 23, Issue 5, pp 360-365
- Burt, R., (1997), 'The contingent value of social capital', *Administrative Science Quarterly*, Vol. 42, pp. 339-365
- Child, J., (2001), 'Trust – The fundamental bond in global collaboration', *Organisational Dynamics*, Vol. 29, Issue 4, pp. 274-288
- Cullen, J.B., Johnson, J.L., Sakano, T. (2000), 'Success through commitment and trust: the soft side of strategic alliance management', *Journal of World Business*, Vol. 35, Issue 3, pp. 223-240
- Danilovic, M., Winroth, M. (2005), 'A tentative framework for analyzing integration in collaborative manufacturing network settings: a case study', *Journal of Engineering and Technology Management*, vol. 22, pp 141-158
- Das, T., Teng, B., (2000), 'A resource-based theory of strategic alliances', *Journal of Management*, Vol. 26, pp 31–61
- Doney, P., Cannon, J., (1997), 'An examination of the nature of trust in buyer-supplier relationship', *Journal of Marketing*, Vol. 61, pp. 35-51
- Frankel, R., Smitz Whipple, J., Frayer, D.J., (1996), 'Formal versus informal contracts: achieving alliance success', *International Journal of Physical Distribution and Logistics Management*, Vol. 26, Issue 3, pp. 47-63
- Fritsch, M., Lukas, R., (2001), 'Who co-operates on R&D?', *Research Policy*, Vol. 30, pp 297–312
- Hart, O., Moore, J., (1999), 'Foundations of incomplete contracts', *Review on economic Studies*, Vol. 66, pp. 115-138
- Hoffmann, W., Schlosser, R., (2001), 'Success factors of strategic alliances in small and medium-sized enterprises – an empirical study', *Long Range Planning*, Vol. 34, pp 357-381
- Hosmer, L.T., (1995), 'Trust: the connecting link between organisational theory and philosophical ethics', *Academy of Management Review*, Vol. 20, Issue 2, pp. 370-403
- Levene, R., (2002), 'Service delivery – preparing for a new future in projects', *Conference proceedings of the 2002 PMI conference*, Seattle, Project Management Institute
- Major, E.J. and Cordey-Hayes, M. (2000), "Engaging the business support network to give SMEs the benefit of Foresight", *Technovation*, Vol. 20, pp. 589-602
- Maskin, E., Tirole, J., (1999), 'Unforeseen contingencies and incomplete contracts', *Review on Economic Studies*, Vol. 66, pp. 83-114
- Nguyen, T., Rose, J., (2008), 'Building trust – Evidence from Vietnamese entrepreneurs', *Journal of Business Venturing*, doi:10.1016/j.jbusvent.2008.03.004
- Rousseau, D. (1995), 'Psychological Contracts in Organisations – understanding written and unwritten agreements', *Sage Publications, New Delhi*, pp 1-21
- Rousseau, D., Sitkin, S., Burt, R., Camerer, C., (1998), 'Not so different after all: A cross-discipline view of trust', *Academy of Management Review*, Vol. 23, Issue 3, pp. 393-404

Ruuska, I., Teigland, R., (2008), 'Ensuring project success through collective competence and creative conflict in public-private partnerships – A case study of Bygga Villa', *International Journal of Project Management*, (Article in Press)

Segers, J., Inceoglu, I. Vloeberghs, D., Bartram, D., Hendericks, E., (2008), 'Proteon and boundaryless careers: A study of potential motivators', *Journal of Vocational Behaviour*, Vol. 73, pp. 212-230

Uzzi, B., (1997), 'Social structure and competition in interfirm networks: The paradox of embeddedness', *Administrative Science Quarterly*, Vol. 42, pp. 35-67

Winter, M., Anderson, E., Elvin, R., Levene, R. (2006), 'Focusing on business projects as an area for future research – an exploratory discussion of four different perspectives', *International Journal of Project Management*, Vol. 24, pp 699-709

Wu, F., Tamer Cavusgil, S., (2006), 'Organisational learning, commitment and joint value creation in interfirm relationship', *Journal of Business Research*, Vol. 59, pp. 81-89

Yli-Renko, H., Sapienza, H., Hay, M., (2001), 'The role of contractual governance flexibility in realising the outcomes of key customer relationships', *Journal of Business Venturing*, Vol. 16, pp. 529-555

## **APPENDIX C – PAPER 3**

Gohil, U., Carrillo, P.C., Ruikar, K.D., Anumba, C., (2009), “Development of a Business Process Model for a Project-Based Organisation”, *International Journal of Knowledge Based Organisations*, (accepted)

**DEVELOPMENT OF A BUSINESS PROCESS MODEL FOR A PROJECT-BASED SERVICE ORGANISATION**

**U. Gohil<sup>1</sup>, P.M. Carrillo<sup>2</sup>, K.D. Ruikar<sup>3</sup>, C.J. Anumba<sup>4</sup>**

<sup>1,2,3</sup> CICE (Centre for Innovative and Collaborative Engineering), Department of Civil and Building Engineering, Loughborough University, UK

<sup>4</sup> The Pennsylvania State University, USA

**Abstract:** Core operations of many small service organisations involved in collaboration are largely on a project (i.e. operational) basis. However, every organisation has operational, organisational and strategic processes that are equally important. The objective of this paper is to establish a business process model for such a project-based service organisation (PBSO) where stakeholders are involved in operational as well as management (organisational and strategic) processes, to create a sustainable collaboration. The focus of the paper was a PBSO and hence a case study of a PBSO firm lead to the development of a new process model that further takes advantage of involving collaborators in all or most of the processes of an organisation. IDEF0 was the preferred process modelling technique for the development of the business process model.

**Keywords:** Project-Based Service Organisations, SME, Business Process Model, Case Study, IDEF0



## Introduction

Over the last few decades, many project-based service organisations catering to knowledge services have been heavily involved in inter-organisational collaboration. These organisations need to understand the effect of their network and organisational boundaries by analysing the firm's interactions with other organisations (Paper, 1998; Ritter & Gemunden, 2004). However, understanding the effect of these organisational boundaries can be difficult due to the organisation's inherent complexity (Paper, 1998). The failure to formally describe it can lead to ambiguity and inconsistency between the collaborators (Wysocki, 2004). One way of tackling this complexity is through modelling parts of the organisation without losing the overall context. The formal modelling of an organisation helps in understanding the organisation and leads to fewer issues with communication and ambiguity.

Every organisation has core processes and management processes that are equally important (Kohlbacher, 2010). In project-based service organisations, a large amount of the time is spent on temporary project settings with transient project structures comprising of internal and external stakeholders. Hence, an issue in such a project setting is the difficulty of these service organisations to involve their collaborators in management (non-core or support) processes. This involvement will help integrate knowledge and organisational structures when projects are viewed as 'singular ventures' in themselves. The value of collaboration within project based service organisations and their collaborators will be enhanced if well-defined core and non-core processes are in place. Such processes would cover the roles and responsibilities of all stakeholders and the flow of information and knowledge during active project periods as well as between projects.

This paper's aim is to develop a business process model for a SME 'project-based' organisation providing services and collaborating with other stakeholders that will lead to an organisational perspective with key strategic, organisational and operational processes. Business Process Modelling (BPM) is chosen here as a vehicle to achieve the aim since, the aims of BPM are to document what is known and understand what is the ideal state in future (Howard & Peter, 2003). It can help to identify processes that become an interface between different collaborating parties.

These processes cut across the collaborative network of the organisation by defining the roles and responsibilities of the stakeholders at each process stages. For a sustainable collaboration in such project-based organisations, there is a requirement to involve collaborators in all the processes of the organisation including the management processes at strategic and organisational levels. In particular, there is a need to develop a process model that is easy to understand and follow by the organisational collaborators of the organisation. A project-based outlook does not always encourage organisations to look at issues faced at the organisational level since the effort is more concentrated on operational (i.e. projects) processes rather than strategic or organisational processes. The paper argues for a need to include the collaborators not only in the operational (project-based) processes but also in organisation's managerial processes to give the collaboration a better strategic intent and help in governance of the collaborative environment. This has been achieved by the development of a business process model for a case study organisation. The paper's structure consists of a literature discussion of project-based service organisations followed by the research method selected, as well as appropriate process modelling techniques and background of the case study. The penultimate section proposes a new process model and the last section identifies the implications through concluding discussions.

### **The Project-Based Service Organisation**

The context of this paper is 'Project-Based Service Organisations' (PBSO). However, to lead on to the definition of PBSO, it is important to first understand what Project-based organisations are? Project-based organisations are an organisational form integrating diverse and specialised intellectual resources and expertise. Hobday (2000) identifies project-based organisations as an organisation where the project is the primary business mechanism for coordinating and integrating all the main business functions of the firm. The statement signifies that there is no formal functional coordination across project lines. Sydow, Lindkvist & DeFillippi (2004) further state that in such organisations projects are embedded in permanent contexts, sometimes resulting in no communication of the strategic intent of the organisation (Thiry & Deguire, 2007).

Whitley (2006) further suggests that such organisations usually organise their work around recurrent projects, and often rely on outsiders (collaborators) for completing individual tasks, while barely retaining a core group of employees for initiating, organising and conducting separate projects. This arrangement ensures that the PBSO remains lean and decrease the managerial overheads. In return, the collaborators are not employees and hence, they are free to pursue their own projects along with projects through the PBSO. In essence, the employees and collaborators are affiliated to the organisational context rather than the project, however making the project work routine rather than the exception. An example of such an affiliation towards the organisational context would be active involvement of collaborators in strategic or organisational decision making processes such as selection of new tools and methodologies.

Project-based organisations have been an integral part of the service industry. A number of service organisations adopt a project-centric organisational culture. The aim of these service organisations is to deliver value to their clients. Such organisations are important as they are often considered the hallmarks of the knowledge-based economy (European Monitoring Centre, 2005). Hence, PBSO are a subset of business services. Such organisations are usually involved with providing knowledge-intensive inputs to business processes of organisations, e.g. business and management consultants, architectural or engineering consultancies or even holding companies involved in management activities.

PBSOs are increasingly involved in collaborative arrangements to distribute some of the work originally covered by employees as internal operations. One of the prominent motivations for such collaborative arrangements is the concept of focusing on core competencies (European Monitoring Centre, 2005). Many PBSO are small firms especially in the consultancy industry. These firms supply a wide range of services, which eventually result in some overlap in the services they provide. Such overlap is typically a result of two possible explanations, a) because their core competence services are not providing them with enough business and hence they diversify in related fields, or b) the small firms are involved with their major client's strategies and hence try to develop special services to integrate their inputs against the client needs (Toivonen, 2004).

Figure 1 below shows an example of such overlapping of types of services provided by a PBSO. In this example, management consultants offer a range of services that sometimes overlap with those provided by other specialist disciplines such as lawyers, scientists and accountants among others.

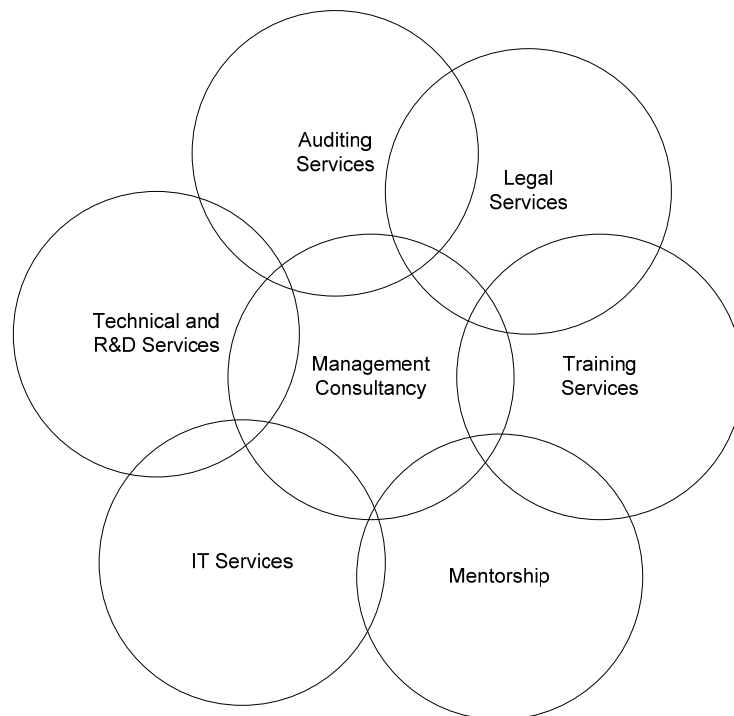

Figure 1 – A conceptual PBSO service offering with example overlaps (Based on Toivonen, 2004)

To avoid dealing with the transaction costs of developing such non-core competencies and to keep the PBSO small and lean, these firms tend to enter into collaborative arrangements (Das & Teng, 2000; Anand & Khanna, 2000; Wysocki, 2004). Such arrangements allow collaborators to pool resources, exploit complementarities and provide quick and flexible access to external resources (Das *et al.*, 2000; Anand *et al.*, 2000; Hoffmann & Schaper-Rinkel, 2001; Belderbos, Carree, Diederer, Lokshin & Veugelers, 2004). However a literature review of such collaborative enterprises demonstrated some typical challenges faced by them:

- Multiple stakeholders with conflicting interests in a collaboration can lead to relational complexity, leading to disagreements and different priorities (Sandhu & Gunasekaran, 2004);
- The challenge to derive a balance of collaborators' involvement in operational (project) processes, as against, organisational and strategy processes, resulting in long-term sustainability of collaboration (Gustafsson, Johnson & Neilson, 2006; Maleyeff, 2006; Huq, 2005; Das *et al.*, 2000);
- Management issues such as poor decision making, lack of support or commitment and lack of internal coordination and standard procedures for strategic activities (Gustafsson *et al.*, 2006; Maleyeff, 2006; European Monitoring Centre, 2005);
- Communication breakdowns to convey to the stakeholders the strategic priorities as well as the governance mechanism (Maleyeff, 2006; Huq, 2005; Belderbos *et al.*, 2004); and
- To maintain the project-based organisational strengths of coping with emerging situations and responding quickly to changing client needs (European Monitoring Centre, 2005).

Fisher (2004) stressed that the effective management and involvement of external stakeholders is an integral characteristic of organisational maturity to overcome the above mentioned issues. Against this background, development of a BPM is a holistic approach to manage such organisations (Pritchard & Armistead, 1999; Rosemann, de Bruin and Power, 2006). A BPM would be helpful in improving the organisational efficiency of the PBSO since the methodology can be applicable to any organised activity (Howard *et al.*, 2003). In the current context not much literature is available particularly dealing with project-based service organisations. The notable exceptions are Johnston (2008) and Sandhu & Gunasharan (2004). Johnston (2008) discussed the barriers to service improvements through involvement of stakeholders, whilst Sandhu *et al.* (2004) explained a model of process development for project-based industry. Hence, the current paper provides another insight into BPM of project-based industries by specifically considering the case of PBSO, since the knowledge economy relies heavily on them.

### **Research Method Adopted**

#### ***Research Design -***

Collaboration in PBSO could be understood through an extensive literature review and study of targeted events or conditions in real-life context. Hence, an investigation to a contemporary phenomenon in a real-life context is required and such studies are best carried forward with case study research (Yin, 1994, Stake, 1995). The intention of this model was to create a central document, for everyone involved in the PBSO, which helped to understand the process structure of the organisation's working as well as guided the collaborators towards working with the PBSO from a strategic viewpoint. The generic research design adopted consisted of the following steps –

- Literature review of umbrella terms like collaboration, service organisations and project-based organisations;
- Understanding the current working practices of a PBSO firm by observing targeted events and conditions in real-life context;
  - Through direct observation,
  - Documents of completed projects,
  - Interviews with Directors of the firm,
  - Interviews with collaborating Associates, and
  - Researcher participation in project work
- Selection of an appropriate modelling tool for business process modelling;
- Development of a comprehensive business process model in consultation with the Directors and Associates;
- Process model validation

#### ***Research Method Implementation -***

For the case study interviews all the three Directors of the organisation were interviewed. In addition, in the first part of the research three other Associates were interviewed as a representative sample of the Associates currently working within the organisation's collaborative network. One of the interviewee was a long term employee of the organisation before becoming an Associate. The other Associates were currently working with the organisations on the projects. At the validation stage, another set of three Associates were interviewed to receive a feedback that was not biased on the expectations of the first batch interviews. This was considered important since, the first batch of Associates and

Directors were heavily involved in developing the BPM. The interview consisted of open-ended questions such as –

- What were the sequences of different activities of work within the organisation?
- How particular activities contributed to the higher goals?
- At particular stages, who had the authority to take decisions?
- What was the documentation used for activities (e.g. training manuals, checklists, reference lists, etc.)?
- The information requirements at each activity stage; and
- How the activities link internal PBSO employees with external collaborators?

These questions resulted in a wealth of primary data describing the actual process of working within the case study. Here, the unit of analysis were individuals working with the case study organisation. In addition, direct observations of the process stages within the case study firm were made while delivering projects. However, Associates being geographically dispersed, Directors were interviewed to identify the milestones when Associates were involved in a particular project. The Directors confirmed that Associates were involved once the prospective project was identified and they wanted the relevant information from Associates to prepare the bid to win projects. Hence, Associates were involved only in the operational activities of the organisation. Directors wanted them to get involved in pre-project activities like identifying the prospective projects, working on tenders, trainings in new tools and techniques between projects, help decide on target sectors for future projects, etc.

Following the Directors' observations Associates were interviewed to get their view. The interviews conducted were open-ended with emphasis on 'storytelling' to convey the project processes involved. Only one Associate knew of the intentions of the Directors to involve Associates in strategic and organisational processes along with operational processes. The result being a clear communication gap between due to lack of a document to convey it. In addition, the motivations of some Associates reflected their wish to get involved in only operational activities, and that had to be factored in the Directors' expectations. Hence, the interviews helped to identify the current problems due to lack of management of information and communication lapses. The result of this exercise was a rich source of support data to the interviews based on which a list of management processes that were needed to be carried out in the PBSO were identified along with a set of project processes.

These were again discussed with the Directors as well as Associates making it an iterative process that ensured two-way communication during the BPM development which ensured a consensus building exercise between the different Associates as well as Directors. It helped in identifying the comprehensive processes further divided into main-processes and sub-processes. They were then modelled with the help of a process modelling tool selected based on the requirements of the collaborative network.

Lastly, the process model was validated against certain criteria by explaining it to Associates that were not previously involved in development of the process model. It was validated against the issues identified as being responsible for the difficulties the case study organisation was facing due to its project-based features. Three separate Associates were involved in this validation consisting of people new to the collaborative network. This

validation was helpful in determining if the process model helped in providing a better strategic intent and governance mechanism to the PBSO.

The strength of this research method was that it tried to identify the extensive variables involved in developing a detailed process model. The methodology adopted was rigorous since it conducted a gradual step-wise method to justify an informed, consistent and efficient change to communicate the business process. However a limitation was that the observations were highly personal in the current case study, as the business process context of a PBSO firm with collaborative relationships had a major emphasis on human interactions and relationships. The next section gives a background to the case study organisation.

### **Case Study Organisation – A background**

For the current research context, the case study organisation was a Small and Medium sized Enterprise (SME) services organisation. It was referred to as ProServe to maintain anonymity. ProServe is a management and advisory business. It was a small project-based organisation consisting of three Directors and hence, wanted to rely on collaborators for completing projects as well as to run some of the strategic and organisational processes within the collaboration.

The decision to use ProServe as a case study for the research project was ideal since it is a project-based organisation providing services (management advisory) for their clients. To maintain the small and lean structure of the organisation, there was a dependence on external collaborators to take the role of Associates. However, since the organisation was a project-based organisation, the Associates did not know their organisational role when there were no projects. Conversely, Directors expected the Associates to help with management activities such as finding new projects, developing case studies and other marketing materials, providing guidance for strategy development and implementation.

In the case study organisation, a lack of a documented induction process made it difficult to integrate new collaborators or employees in this relationship or bring any required changes to the existing business processes. All external collaborators took the project view of their work and hence, involuntarily distanced themselves from strategic and organisational processes such as finding new projects, development of new tools and technologies and development of marketing materials. This distance was forced by the lack of a communication of the collaborators' role at strategic level. The Directors as well as Associates agreed that a document with the business processes and their process owners would help in clearly communicating the roles expected of each individual.

Davenport *et al.* (1996) analysed and illustrated how knowledge-intensive service industry processes tend to be characterised by frequent changes in goals, constraints and has individual and ad-hoc communication and collaboration patterns. It is also true in project-based service organisations where the current projects determine the strategic and organisational outlook. Business Process Modelling could be used as a technique to keep track of these changes in goals, constraints and communicate them to all stakeholders of a PBSO. The the next section provides a discussion on the business process modelling techniques in the current context.

### **Business Process Modelling**

Business process modelling was considered an established way for organisations to identify bottlenecks in their processes (Van der Aalst, Van Dongen, Herbst, Maruster,

Schimm & Weijters, 2003; Vergidis, Turner & Tiwari, 2008). In terms of PBSO, most of these bottlenecks are associated with the inability of the organisation to include its collaborators in strategic as well as organisational processes. Here, an organisation can either take the route of one-off big change or decide on incremental changes. The Business Process Reengineering (BPR) perspective consists of one-off revolutionary changes, while BPM strives to understand the key mechanisms of a business and hence, improve business efficiency (Van der Aalst *et al.*, 2003; Kohlbacher, 2010). BPM is preferred for PBSO firms since it is an incremental process which doesn't redesign processes per se but starts with the current processes and conduct low risk, incremental improvement within PBSO. Business processes are often too narrowly defined and relevant stakeholders thus fail to be included in BPM initiatives (Rosemann *et al.*, 2006). Hence, from the PBSO perspective, BPM undertook a holistic understanding of management of processes, on an ongoing basis, to make systematic use of the know-how which lies outside of organisational boundaries through the external stakeholders.

BPM techniques capture different aspects of a business processes. The most common diagrammatic techniques for BPM are flowcharts, Interim Data Exchange Format (IDEF), role activity diagrams, data flow diagrams and Petri-nets (Aguilar-Saven, 2004). Extensive literature (Aguilar-Saven, 2004; Bridgeland & Zahavi, 2009) is available on the different business process modelling techniques. However, it was important that the technique selected should be relatively easy to understand by the collaborators of the PBSO firm. The objectives behind developing a process model decide the selection of a business process modelling technique. Ideally, the process model needs to be developed with a tool or technique that is clear to understand, has standard syntax, easy to generate and accurate in representation.

### **IDEF0 model for ProServe**

The roots of business process modelling were in systems engineering where complex interdisciplinary engineering projects needed to be modelled (Climent, Mula & Hernandez, 2009). However, business processes in a PBSO could be hard to track since there were no physical manufacturing lines to follow the logical flow of the business process. Hence, there was a requirement for a process-mapping tool that can model a series of process instances that lead to a common goal. The process model assisted in developing a flexible resource coordination model to perform projects (core processes) as well as to carry out strategic activities (management processes). The purpose of this exercise was communicated to the Directors as well as the Associates before the start of process model development. It was followed by the identification of attributes that were important for the current context to be covered within the process model. In the current scenario, ease of collaboration was the perspective of the process model since SME-PBSOs are highly dependent on such collaborations for getting a competitive advantage.

The Directors of ProServe and three Associates were interviewed to find out their requirements from the process model to be developed. After getting views from both the parties, it was agreed that the process model needed to cover the following based on the perspective of process model development:

- A formal model with standard syntax (language rules) for an enterprise (organisation and collaborators) wide consistency;
- Supportive model documentation that would eventually help in determining the audit trails and different record keeping requirements for quality systems like ISO;

- An adaptive model that is responsive to changes;
- An easy to understand, user-friendly model. The model needs to have a degree of flexibility and thus, every possibility is not required to be represented within it; and
- Lastly, it needs to be coherent and complete.

This research explored the development of a process model for the collaboration processes between ProServe and its Associates using the IDEF0 modelling system. The IDEF0 method was selected for the process modelling since it covered the above mentioned attributes in varying degrees. In addition, IDEF0 is industry as well as technology-independent, hence, easy to understand by Associates from a wide variety of industrial background. It provided a means to drill down from high levels to detailed views, so that the system integrity could be verified.

IDEF0 was preferred over other process modelling techniques, since it provided preferable properties, as evident from Table 1. Table 1 reflects the major advantages of IDEF0 over other modelling techniques. IDEF0 was particularly strong in properties such as completeness and accuracy but a weakness was that it was interpreted as a sequence of activities which is not always true in an organisational context. The IDEF0 modelling system was a structured design and analysis technique based on graphics syntaxes and semantics. This system provided the ability to produce a process model that is descriptive, as well as, comprehensive which was the requirement as previously noted in the business process modelling section of this paper.

Table 1 : Required properties of the Business Process Model in the Current Context

No	Properties (Kock et. al., 2009)	Description	IDEF0 strength	Comparison with other techniques (Based on Aguilar-Saven, 2004)
1	Ease of Generation	How easy it is to conceptualise, create and use	Moderate	Flow Chart - Strong; Data Flow Diagrams - Strong; Petri-Nets - Very Weak
2	Ease of Understanding	Clear graphical representation and easy to understand	Moderate	Flow Chart - Strong; Data Flow Diagrams - Strong; Petri-Nets - Strong
3	Accuracy	Accurate process representation	Strong	Flow Chart - Weak; Data Flow Diagrams - Moderate; Petri-Nets - Strong
4	Completeness	Complete rather than partial representation	Very Strong	Flow Chart - Weak; Data Flow Diagrams - Moderate; Petri-Nets - Very Strong



The IDEF0 model presented incorporated all the business processes that a PBSO requires. The model presented here was composed of three levels opening with the context diagram, followed by parent diagram and child diagrams. The overall model aims to give an overview of all the important activities to effectively manage the strategic and operational management activities of the PBSO.

### **Context Diagram**

For the current research, the overall process of managing a PBSO firm was put in context through a context diagram. Node CW is the context diagram that embodies the top level process. This top level process gave a general view of the management of a PBSO firm (refer to Figure 2). The context diagram provided the subject of the business model, the boundaries of the model as well as the external interfaces of the model. The process input consisted of the prior experiences of the firm Directors, the client brief and the perceived market gap to produce outputs such as core service offerings, certified Associates, satisfied clients, etc. This process is carried out in the constraints such as external market conditions, regulations and IP rights. They develop into the controls of this arrangement. The mechanism of such a process consists of all the collaborative parties (Directors, Associates, networks, etc) and the reviews and case studies of previous work.

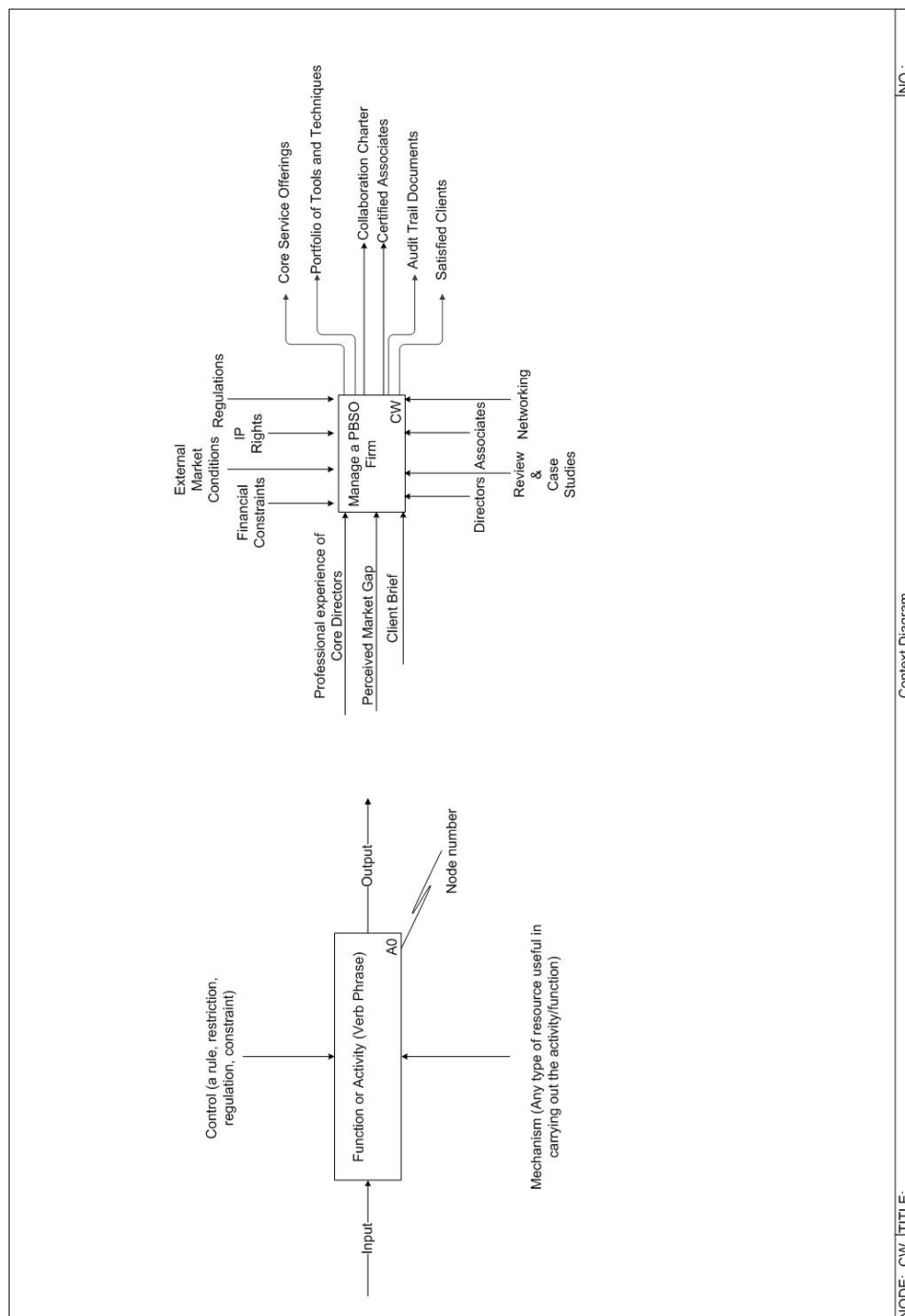

NO.:

Context Diagram

NODE: CW TITLE:

Figure 2: Context Diagram

**Parent Diagram**

Node A0 (Figure 3) represented the parent diagram of ProServ’s process of collaborative working. The parent diagram consisted of the processes identified to manage the firm grouped in three to six headings to form the main processes. These headings had to consider issues related to the nature of the services organisation like winning projects followed by execution as compared to production before sales in manufacturing organisations. In addition, it had to consider issues related to the collaborative nature where special attention had to be given to the development of an Associate team and through training in collaborative tools.

The process is hierarchical in nature and starts with the strategising of the key sector portfolios. The professional experience of the Directors as well as the perceived market gap

helps in strategizing key sector portfolios for ProServe, hence they are the inputs in A1. The strategising of the key sector portfolio is helpful in identifying the types of projects that ProServe should try to win in accordance with their work philosophy. At this stage, the mechanism to strategize key sector portfolios was the Directors with their knowledge and the market information available from trade organisations and other sources. The controls at that stage are the finances available to the Directors of ProServe along with the prevailing external market conditions and regulations/laws. A1 process helps ProServe in identifying its internal capabilities, core service offerings, corporate values as well as short, medium and long term financial and growth (SML Finance & Growth) goals. Hence all of the above are the outputs of this activity.

The next process is to acquire portfolio of tools and techniques. The management and advisory business required different management tools and techniques to win professional services projects. The inputs to this activity were the perceived market gaps along with core service offerings and target sectors that activity A1 established. The market gaps identified the different tools and techniques required in the organisation while the target sectors along with core service offerings help in identifying the priorities for acquiring new tools. The controls for this activity consisted of the financial constraints of ProServe and the Intellectual Property rights for the tools and techniques. The activity was guided by the SML (Small, Medium and Long) Finance & Growth goals determined in A1. The owners of the licensed tools became strategic partners and hence mechanisms for this activity along with the books/manuals and presentations/workshops. The output of this activity is the portfolio of tools and techniques to provide the services to ProServe's clients as well as ProServe's training requirements for this portfolio.

Establishing the core Associate team becomes the third process in the parent diagram. Limited availability of human resources within ProServe leads to skills shortage, resulting in a need to establish a core Associate team. The input of this activity is the perceived market gaps. The activity is regulated by the target industry sectors, the geographical coverage that ProServe can handle, the corporate values that ProServe wants to adhere by and the SML Finance & Growth plans. The mechanism to carry out this activity consists mainly of the networking the Directors of ProServe conduct along with the interest shown by the prospective Associates. The output of this activity is a collaboration charter to guide the relationship between ProServe and Associates. In addition, training requirements of the Associates are identified after establishing the core Associate team.

A4 shows the training requirements of Associates. The portfolio specific training requirements form the input for the activity of managing Associate team training. The controls of this activity are the financial constraints of ProServe along with the SML growth goals, while the mechanisms for the activity are the human resources (i.e. Associates and strategic partners) and presentations/workshops along with the library of books and manuals available to ProServe and its Associates. Sometimes additional inputs derived from case studies and reviews are also a mechanism to provide Associate team training. The outputs of this activity would be a team of trained and certified Associates.

The penultimate process is to win new projects. The inputs of A5 activity are the portfolio of tools and techniques along with the trained Associate team and the client prospects identified by the Associates. In addition, previous project clients can provide the opportunity for repeat business. As pointed out in Figure 3, along with the controls of collaboration charter and prevailing market conditions, ProServe also depends on the

Associates' time-in-kind for preparing bids and marketing for winning new projects. The mechanism to achieve the activity depends on the Associates and Directors attending networking events and using the different sources of media like internet and publications. The output of this activity would be formulated sales targets, weighted prospects list and rolling view of commitments from Associates along with the winning bids.

Eventually, the portfolio of tools and techniques along with the winning bid and the client brief are the inputs for executing the projects. The activity would be regulated by many factors such as the collaboration charter, external market conditions and regulations. The Directors and Associates are involved in executing this projects and the outcome of this activity are the satisfied clients, the project audit trail documents, case studies and reviews along with possible opportunities for repeat business.

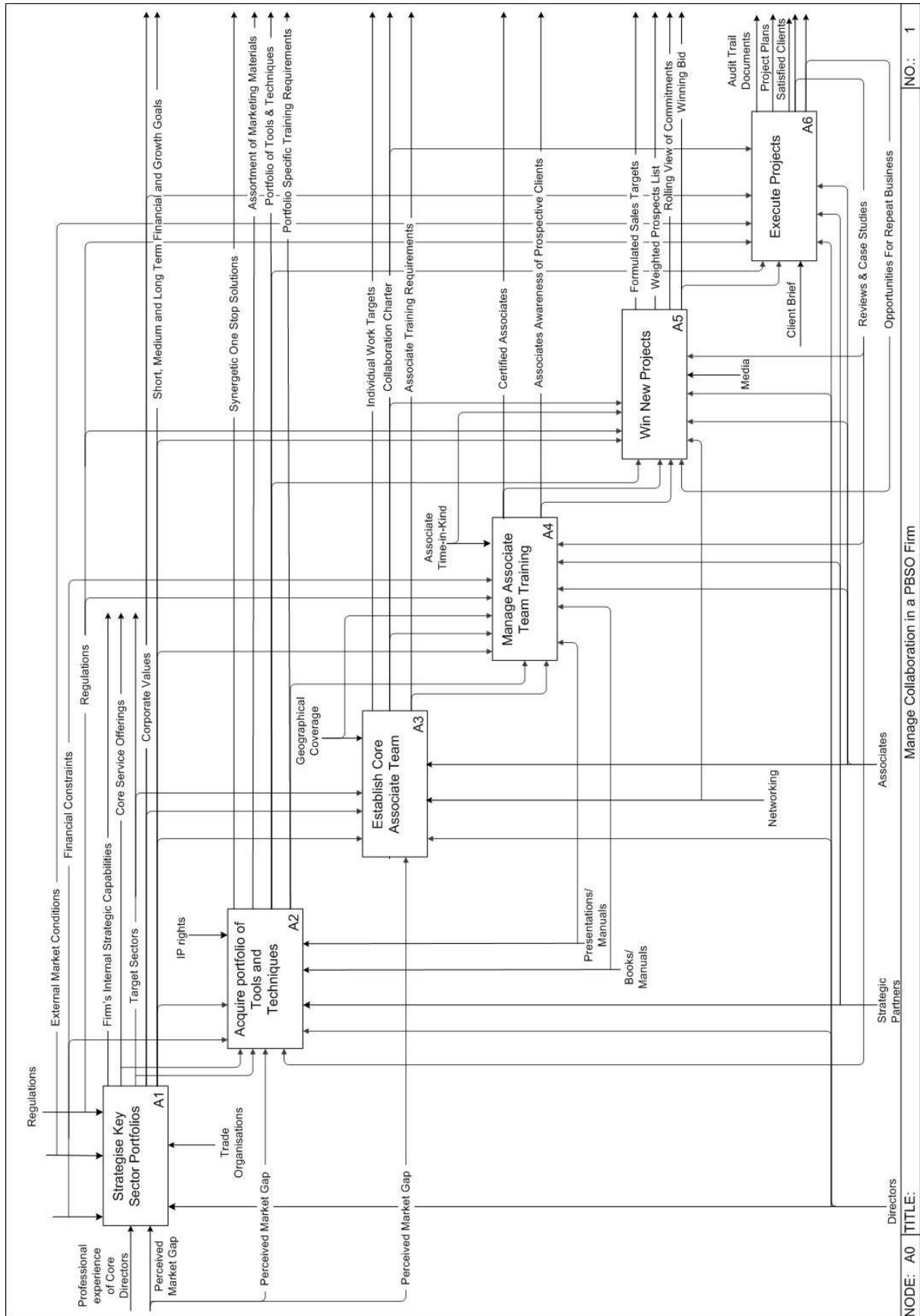

Figure 3: Parent Diagram

### Child Diagrams

Decomposition of the main activities was the next stage of IDEF0 development for ProServe collaboration. The decomposition of each of these main activities was carried out until the required level detail was obtained. The required level of detail for the current project is a stage where all the activities of ProServe and Associates are understood. In addition it is deemed important to understand roles of each collaborator and the information flow in detail. The table below (Table 2) provides the main sub-processes under each of the main processes (A1 to A6) resulting in six IDEF0 child diagrams.

Table 2: IDEF0 Sub-processes after decomposition of Node A0 processes

Main Process IDs	Main processes	Sub-process IDs	Sub-processes
A1	Develop Strategic Plan <sup>a</sup>	A1.1	Identify internal strategic capabilities
		A1.2	Identify core services and value proposition
		A1.3	Develop financial and growth goals
		A1.4	Conduct market sensing
		A1.5	Decide the target sector portfolios
A2	Acquire portfolio of tools and techniques	A2.1	Collate/search tools and techniques for core services
		A2.2	License/Buy tools and techniques
		A2.3	Develop appropriate additional complementary tools
		A2.4	Establish internal tools synergies for one-stop service offerings
		A2.5	create assorted marketing for ProServe tools and techniques
A3	Establish core Associate team	A3.1	Identify prospective Associates
		A3.2	Determine Associates' expectations
		A3.3	Develop and sign a collaboration charter
		A3.4	Conduct periodic strategic workshops
		A3.5	Establish periodic review process
A4	Manage Associate team training	A4.1	Engage strategic partners in Associate training
		A4.2	Derive cost structure of Associate training programs

		A4.3	Conduct Associate training programs
		A4.4	Receive training feedback
		A4.5	Create Associate based marketing strategy
A5	Perform marketing activities	A5.1	Create sales targets
		A5.2	Identify prospects/ Leads generation
		A5.3	Populate the prospects database
		A5.4	Develop and submit bid
A6	Execute projects	A6.1	Agree contract terms
		A6.2	Confirm project Associates and resources
		A6.3	Hold project kick-off meeting
		A6.4	Approve project plan
		A6.5	Implement action
		A6.6	Provide post contract services

These diagrams cover all the activities of ProServe starting from the stage of developing a strategic plan. The strategy plan identified internal core strategic capabilities, ProServe values as well as the core services it wants to provide. Once core services were identified, the Directors need to develop financial and growth goals, conduct market sensing exercises and eventually decide on the key target sector portfolios.

Acquiring a portfolio of tools and techniques was identified as the next stage of the ProServe's process. It consists of some activities that are not always sequential. The process would start with the collating as well as searching tools and techniques that can help ProServe provide the core services to its clients. This search can lead to one of the two ways of procuring tools and techniques, if there is something similar already available in the market and under the budget then ProServe will try to license or buy it. However, sometimes it is a cheaper option to develop tools complementing the required core services. Both these processes are almost parallel. For e.g. if ProServe wants to provide *strategy planning* as a service to a client, then if ProServe's portfolio already does not have a strategy related tool or technique, then they need to either develop it or procure it from the market. The acquired tools can be from different industries and hence it is required for ProServe to establish internal synergies between these tools to provide a one-stop service offering portfolio. Lastly, assorted marketing materials needs to be generated based on the tools available.

Node A3 is the establishment of the Associate team. The initial sub-process within this node is to locate prospective Associates who might be interested in joining ProServe for collaborative working. At this stage Directors as well as existing Associates want to find out the expectations of the prospective Associates and communicate ProServe's expectation. Conducting periodic workshops help in establishing trust and commitment towards the collaboration since it puts initiative on the Associates to get involved in strategy planning and implementation along with the normal project activities.

Establishment of Associate team is followed by the process of managing the Associate team training. It is important to engage the strategic partners into the Associate

training program for maximum benefits to all collaborators. This engagement will help prepare a cost structure to Associate training based on their previous experience in the target area/tools and techniques. Next a comprehensive training programs based on the requirements and interests of participants is developed. The feedback of these programs help to design and make changes to future programs. Lastly an Associate based marketing strategy is created to obtain maximum benefits from this training.

The penultimate process is to perform marketing activities based on the strategy developed. The process contains the important sub-process of creating sales targets. The targets would help identify prospective projects and hence prospects and leads are generated. Once the prospects are uploaded on the prospects database and a decision is taken to bid for the project, the bid is developed and submitted.

The last process consists of executing the project. The process is initiated with the agreement on the contract terms. ProServe then needs to confirm the participation of project participants for the particular project as well as other resources. The project kick off meeting is the initiation of the actual project and first steps towards approving a project plan. It is followed by execution of the contracts and lastly information and feedback is collected and other post contract services are provided.

Figure 4 shows the child diagram for Node A6 – Execute Project. The next section discusses the validation of the process model.



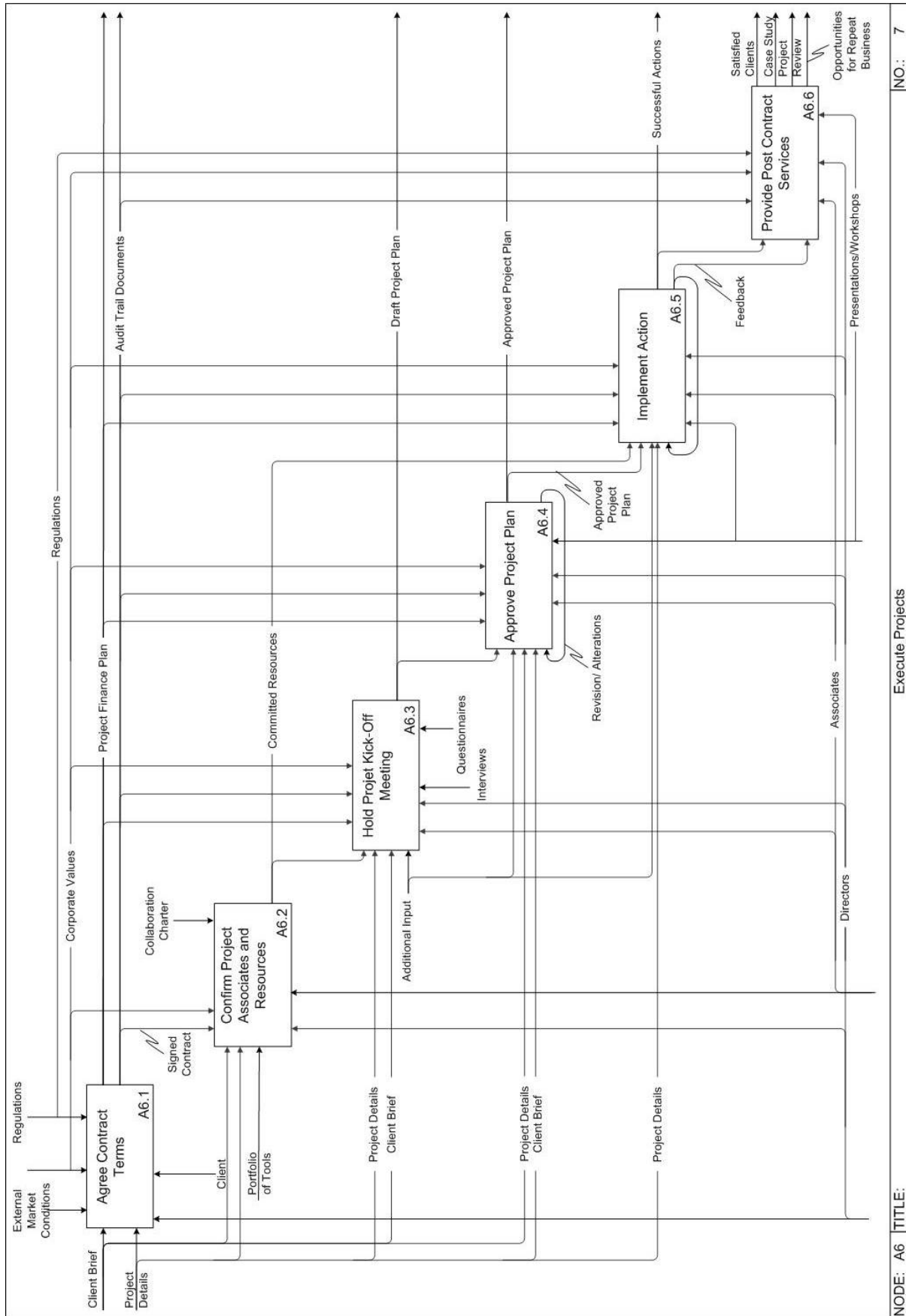

Figure 4: Child Diagram for Node A6

### **Model Validation**

The model validation can be described as a process that made a judgement if the business process model was fit for the purpose it was generated. The completed process model was validated against the challenges a PBSO firm faces for better governance, identified previously in this paper based on the review of literature while the validation was undertaken against the context (a PBSO firm). Hence, the validation was conducted with the collaborators working with ProServe, as they had the tacit as well as explicit knowledge of how the collaboration worked in ProServe as well as the issues of the collaboration before the business process model was developed.

The model validation consisted of individual interviews since the collaborators were geographically distributed. However, ProServe is an SME and hence three interviewees that were previously not directly involved in the development of the business process model were considered appropriate.

The interviewees felt that the process model helped to comprehend most of the ProServe's expectations of the Associates and vice-versa. The exercise assisted in control and compliance within the collaboration directly resulting in clear decision-making processes. According to the Director, a direct result of the business process model was the evidence gathering that led to the case study firm getting an ISO 9001 (2008) accreditation. The interviewees were asked validation questions regarding IDEF0 model's ease of applicability, completeness, adaptability, readability, conciseness and coherency. The interviewees felt that the coverage of the model was comprehensive to provide completeness. However, if the Associate was not used to reading IDEF0 then might require user-friendly interface simpler in syntax to make it clearly understandable. Lastly, they were asked if the content of the process model was inclusive of their expectations as well as what were the prospective benefits of the new model.

The interviewees felt the new process model did ensure that the project based organisational work was maintained while taking care of the governance issues faced previously. This was achieved by isolating the project related processes in node A5 and A6 while node A1 was related to strategic processes and; node A2 and A3 primarily dealt with the organisational processes. Under all these nodes, the involvement of collaborators and hence process owners and enablers were identified.

The interviewees felt the process model provided a better strategic work model for the organisation that is predominantly depending on external collaborators for certain important functions within the organisation. In addition, the interviewees pointed out the following additional benefits of this process model.

#### *Communication of information requirements at each process stage*

The process model helps assisted identification of different types of information required either relating to the controls of the process or the inputs for a process. For example, the Collaboration Charter provided the control for manage Associate training and execute new projects. Hence, it made clear the role of the different collaborators in the PBSO.

#### *Generating service value*

The processes related to the service created more value when every collaborator involved knew why a certain process was required and the value of the output of that process. For example, identifying key target sectors with the help of Associates determined the best

possible chances to win new projects based on the strength of the collaboration. Hence it is value enhancement of the processes carried out in an organisation.

#### *Enabling an auditable trail*

A standard practice is useful was providing an auditable trail for the PBSO. The results of the current process model were useful as an evidence to get ISO 9001: 2000 accreditations in the organisation.

#### *Information management*

The proposed process model was helpful in generating accurate information that could be used for marketing purposes, for providing information to clients and for managing information internally. In addition, it provided a chance for regular reviews of the processes.

### **Conclusions**

The introduction of the paper described the development of knowledge intensive service organisations as project-based organisations with collaborative arrangements. Such organisations give high importance to temporary work structures resulting in a struggle to integrate knowledge and provide the organisation's strategic intent. Hence, the context of this paper is PBSO. First, based on the review of the literature, typical issues were identified for such PBSO consisting of multiple stakeholders with conflicting interests, lack of stakeholder involvement in strategic and organisational processes, management issues like poor decision making and communication breakdowns. To find a solution for the above mentioned challenges, Business Process Modelling was chosen as a medium.

A detailed business process model was developed for a particular PBSO case study firm with the help of IDEF0 modelling to provide effectiveness to the organisational processes. It also provided effective strategy implementation of processes and provision of operational process efficiency for the PBSO. The three tier decomposition of the IDEF0 process model for the case study organisation aimed at giving an overview of all the important activities. The BPM in terms of IDEF0 diagrams was able to address the underlying challenges of a PBSO by generating a mechanism to conduct repeatable business functions leading to communication of expectations from this arrangement, increasing efficiency through consistency of the process.

From a practitioner's perspective, the findings of the work suggested that, despite the best intentions of the PBSO involved in collaboration, there are significant challenges to sustain competitive advantage through collaboration. The need for BPM in a PBSO is clearly outlined in the 'Introduction' section. The IDEF0 process model provided a better understanding of the business to all stakeholders; it facilitated improvement in communication within ProServe and collaborators; and it was an ideal medium for potential collaborators to see the process ownerships in place. The validation showed that management practice of ProServe was already gaining from the research (by getting ISO 9001 certification and getting more involvement from stakeholders in organisational processes like Associate trainings) and hence, the objectives of the research had been successfully achieved. Although it is difficult to generalise since a single organisation was studied with small number of interviewees, however, one might speculate that similar organisations would consider this exercise to ease the collaboration issues in similar PBSO. It is also important to periodically go back to the developed process model and make required changes to better reflect the condition of the collaboration at a particular point of time.

From an academic point of view, the current work increases the knowledge domain of PBSO involved in collaboration which was not covered by previous work. It encourages to view the overall business by breaking it into detailed processes and involving collaborators at each process stage. Hence, this paper academically emphasises the need for business process models to be developed with a collaborative consultation of all stakeholders. PBSO and their collaborators can provide services with a change from the traditional project-based view by inclusion of the collaborators in strategic decision making as well as organisational processes.

### References

- Aguilar-Saven, R.S. (2004). 'Business process modelling: Review and framework'. *International Journal of Production Economics*. Vol. 90. pp 129-149.
- Anand, B. & Khanna, T. (2000). 'Do firms learn to create value? The case of alliances'. *Strategic Management Journal*. Vol. 21. pp. 295-315.
- Belderbos, R., Carree, M., Diederens, B., Lokshin, B. & Veugelers, R. (2004). Heterogeneity in R&D co-operation strategies. *International Journal of Industrial Organization*. Vol. 22. pp 1237-1263.
- Bredin, K. (2008). 'People capability of project-based organisations – A conceptual framework'. *International Journal of Project Management*. Vol. 26, pp. 566-576.
- Bridgeland, D.M. & Zahavi, R. (2009). *Modelling Fundamentals: Business Modelling*. Pages 19-40.
- Climont, C., Mula, J. & Hernandez, J.E. (2009). 'Improving the business processes of a bank'. *Business Process Management Journal*. Vol. 15, No. 2, pp. 201-224
- Das, T. & Teng, B. (2000). 'A resource-based theory of strategic alliances'. *Journal of Management*. Vol. 26. pp 31-61.
- European Foundation for the Improvement of Living and Working Conditions. 2005. 'Sector Futures – The Knowledge-Intensive Business Service Sector'. *Report by European Monitoring Centre on Change*. pp. 2-29.
- Fisher, D. M. (2004): 'The Business Process Maturity Model'. *A Practical Approach for Identifying Opportunities for Optimization*. pp. 5.
- Gustafsson, A., Johnson, M.D. & Nilsson, L. (2006). 'Improving the customer orientation process', in Llosa, S., Mathieu, V. and Orsinger, C. (Eds), *Proceedings of the 9th International Research Seminar in Service Management*, La Londe les Maures, France, June, pp. 354-73.
- Hobday M. (2000). 'The project-based organisation: an ideal form for managing complex products and systems?' *Research Policy*. Vol. 29. pp. 871-93.
- Hoffmann, W.H. & Schaper-Rinkel, W. (2001). 'Acquire or ally – A strategic framework for deciding between acquisition and collaboration'. *Management International Review*. Volume 4. pp. 131-159.
- Howard, S. & Peter, F. (2003). *Business Process Management. The Third Wave*. MK Press
- Huq, Z. (2005). 'Managing change: a barrier to TQM implementation in service industries'. *Managing Service Quality*. Vol. 15. No. 5. pp. 452-70.
- Johnston, R. (2008). 'Internal service – barriers, flows and assessment'. *International Journal of Service Industry Management*. Vol. 19. No. 2. pp. 210-231.
- Lindkvist L. (2004). 'Governing project-based firms: promoting market-like processes within hierarchies'. *Journal of Management Governance*. Vol. 8. pp. 3-25.
- Kock, N., Verville, J., Danesh-Pajou, A. & DeLuca, D. (2009). 'Communication flow orientation in business process modelling and its effect on redesign success: Results from a field study'. *Decision Support Systems*. Vol. 46. pp 562-575.

- Kohlbacher, M. (2010). 'The effects of process orientation: a literature review'. *Business Process Management Journal*. Vol.16. No. 1. pp. 135-152
- Maleyeff, J. (2006). 'Exploration of internal service systems using lean principles'. *Management Decision*. Vol. 44. No. 5. pp. 674-89.
- Melao, N. & Pidd, M., 2000. 'A conceptual framework for understanding business process modelling'. *Information Systems*. Vol. 10, pp 105–129.
- Paper, D. (1998). BPR: 'Creating the conditions for success'. *Long Range Planning*. Vol. 31. No. 3. pp 426-435.
- Pritchard, J.-P. & Armistead, C. (1999) 'Business Process Management - Lessons from European Business', *Business Process Management Journal*. Vol. 5. No.1. pp. 10-32.
- Rosemann, M.; de Bruin, T.; Power, B. (2006), 'A Model to Measure Business Process Management Maturity and Improve Performance'. In Jeston, J.& Nelis, J. (Ed.): *Business process management: practical guidelines to successful implementations*. Burlington, pp. 299-315.
- Ritter, T. & Gemunden, H.G. (2004). 'The impact of a company's business strategy on its technological competence, network competence and innovation success'. *Journal of Business Research*. Vol. 57. pp 548-556
- Sandhu, M.A. & Gunasekaran, A. (2004). 'Business process development in project-based industry'. *Business Process Management Journal*. Vol. 10. No. 6. pp 673-690.
- Stake, R. E. (1995). *The art of case study research*. Thousand Oaks, CA: Sage.
- Sydow J, Lindkvist L & DeFillippi R. (2004). 'Project-based organizations, embeddedness and repositories of knowledge: editorial'. *Organisational Studies*. Vol. 25. Issue 9. pp. 1475–89.
- Thiry, M. & Deguire, M. (2007) 'Recent Developments in Project-based Organisations'. *International Journal of Project Management*. Vol. 25. pp. 649 – 658.
- Toivonen, M. (2004). 'Expertise as business: Long-term development and future prospects of knowledge-intensive business services (KIBS)', Helsinki, Helsinki University of Technology, Doctoral dissertation series 2004/2, available at: <http://lib.tkk.fi/Diss/2004/isbn9512273152/> last visited on 15/06/2009.
- Vergidis, K., Turner, C.J. & Tiwari. A. (2008). 'Business process perspectives: Theoretical developments vs. real-world practice'. *International Journal of Production Economics*. Vol. 114. pp 91-104.
- Whitley R. (2006). 'Project-based firms: new organizational form or variations on a theme'. *Industrial Corporate Change*. Vol.15. pp 77–99.
- Van der Aalst, W.M.P., Van Dongen, B.F., Herbst, J., Maruster, L., Schimm, G. & Weijters, A.J.M.M. (2003). 'Workflow mining: A survey of issues and approaches'. *Data and Knowledge Engineering*. Vol. 47. Issue 2. pp 237-267.
- Yin, R.K. (1994). *Case study research: Design and methods*. (second ed.) Sage Publications. Thousand Oaks, CA.



## **APPENDIX D – EXECUTIVE SUMMARY OF SERVQ TOOLS AND TECHNIQUES**

This appendix provides the summary of the principal ServQ tools used for collaborative working. These tools in isolation or in conjunction with other tools were used for serving the needs of the client organisations by ServQ and their Associates.

- BEACON
- Implication's Wheel
- Target Costing
- Activity Based Costing/Management
- Partnership Continuum
- Value Management Framework

### BEACON

**Overall aim of the Tool:** The aim of the tool is to enable construction industry participants to evaluate and benchmark their project delivery process in terms of concurrent engineering. It also identifies area requiring improvement or change. It also helps in developing collaborative working in an active business partnership to deliver real, measurable readiness.

**Key Features of the Tool:** The tool essentially is used to carry out the readiness assessment of concurrent engineering with respect to the four key elements of Process, People, Project and Technology.

1. Process factors assess the process maturity level of a construction organisation including the sub-elements of Management Systems, Process Focus; Organisational Framework; Strategy Deployment; and Agility.
2. People factors assess the team level issues within the organisation including the sub-elements of Teams in an Organisation; Discipline; Team Leadership and Management; Team Formation; and Development.
3. Project factors assess the client's requirement and design related issues including the sub-elements of Facility Design; Quality Assurance; and Client Focus.
4. Technology factors characterise the introduction and utilisation of advanced tools and technology within the organisation including the sub-elements of Communication Support; Coordination Support; Information Sharing; Integration Support; and Task Support.

**How to use the Tool and Processes Involved:** The tool is questionnaire based developed in access format. The questions fall into the four categories of Process, People, Project and Technology.

Once the questionnaires are filled up, the computer model will create a spider chart to show the Maturity level of each of the key elements and the sub-elements in an organisation. The table below describes the BEACON Model Maturity Levels.

Table 1: BEACON Model Maturity Levels

Maturity Levels	Description
Ad-hoc	This level is characterised by ill-defined procedures and controls, and by confused and disordered teams that do not understand their assignment or how to operate effectively. Informal interaction with the client is observed management of the project development process is not applied consistently in projects, and modern tools and technology are not used consistently.
Repeatable	Standard methods and practices are used for monitoring the project development process, requirements changes, cost estimation, etc. the process is repeatable. There are barriers to communicate within the project development team. Interaction with the client is structured but it is only at the inception of the project. Minimal use of computer and computer based tools.
Characterised	The project development process is well characterised and reasonably well understood. A series of organisational and the process improvements have been implemented. Teams may struggle and fall apart as conflicts are addressed but a team begins to respect individual differences. Most individuals are well aware of client's



	requirements but client is not involved in the process. Moderate use of proven technology for increasing group effectiveness.
Managed	The project development process is not only characterised and understood but is also quantified, measured and reasonably well controlled. Tools are used to control and manage the process. The uncertainty concerning the process outcome is reduced. Work is accomplished by the project development team and conflicts are addressed. Client is involved throughout the process. Appropriate utilisation of available technology and computer-based tools.
Optimising	A high degree of control is used over the project development process and there is a major focus on significantly and continually improving development operations. Team performance is regularly measured and performance measures are continuously validated. Client is a part of project development team from inception and all project decisions are prioritised based on client's needs. Optimal utilisation of appropriate plant and technology and technology-mediated group work is observed.

These maturity levels help in indicating the areas that require immediate attention from project participants for appropriate performance. The figure on the next page depicts a typical case study result developed by BEACON for a client.

As the BEACON model can be a time consuming process, a more cost effective and efficient method for the purpose resulted in developing Beaconlite. Beaconlite takes only some questions from the total list of questionnaires and is developed in a web format. Thus, online questionnaire filling saves time and the results give an idea of the weak areas for Concurrent Engineering adoption which can be then again accessed properly with the help of BEACON.

#### Benefits and Limitations:

Benefits:

- The survey and assessment using the BEACON software could be completed by remote respondents;

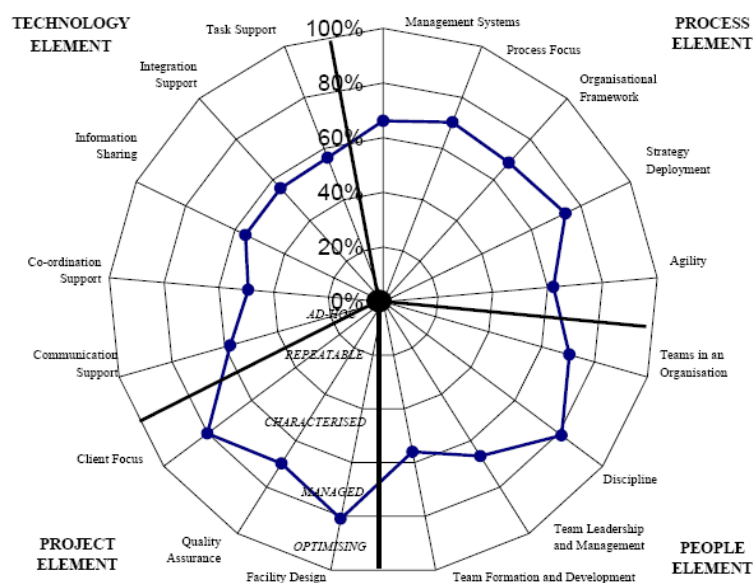

Figure 1: An example of BEACON spider chart

- The BEACON software could be used in two ways: it could be put on a network and be accessible to everyone, or alternatively could be e-mailed to a company wishing to carry out the assessment. The Beaconlite software is web-enabled and can be accessed by web;
- The software does not require physical presence of assessor to look into questionnaire responses manually;
- With the software, it's easy to compare current readiness assessment with the previous results;
- Even if the organisation is not considering implementing CE, the software can act as a useful tool for self-assessment on the four key elements.

**Limitations:**

- The current state of the software is a prototype version;
- The software needs enhancement in certain areas i.e. improvement in screen appearance and introduction to help features, etc;
- A report generation module needs to be introduced, which can indicate areas requiring immediate consideration for improvements and solutions for any lacking, along with diagrammatic representation.

**References:**

Khalfan, M.M.A., 2001, Benchmarking and Readiness Assessment for Concurrent Engineering in Construction (BEACON), Loughborough University, unpublished PhD

### **Implications Wheel by Joel Barker**

**Overall aim of the tool:** The Implications Wheel is a strategic exploration tool which helps in enhancing decision-making. One of the key uses of Implications Wheel can be in determining the likely success of the strategic alliances.

**Key features of the tool:** The Implications Wheel helps in:

- Strategic exploration by explaining all possible implications;
- Gathering observations about what might occur, including the positive and negative outcomes; and
- The implications of actions and inactions.

The tool is computer based thus helping the document management of the process. It helps in first defining the questions most important to the future of any organisation. It then gathers and synthesizes the relevant knowledge inherent in the business to consider. The tool provides a deeper awareness and clear understanding of critical paths to success. It also helps in seeing the business change in a dynamic visual model that highlights alternatives and implications of one's actions and inactions.

#### **How to use the tool and main processes involved:**

The tool requires an I-Wheel facilitator, someone trained to conduct the use of I-Wheel in an organisation. The process is mainly divided into three parts which is represented in the figure 1 below:

*Part 1:* The I-wheel facilitator and senior management need to generate proper goals, which should be measurable in the future and is not just a general statement. Then both parties meet to determine the first order implications of a goal.

*Part 2:* This consists of forming small groups which can consist of senior management, employees, clients or suppliers. The groups work with the I-wheel facilitator to form the second order and third order implications (See figure 2 for GUI). The facilitator would need to explain the rules to the workshop participants before conducting the exercise. Once the implications are generated for each of the first order implications, they need to be scored for likelihood and desirability as well as timescales.

*Part 3:* This comprises of modelling all the implications collectively and determining the 'bridges' and 'barriers'. These assist to know how to use effectively the knowledge generated through the Implications wheel exercise.

#### **Benefits and Limitations:**

*Benefits:* The benefits of such a tool are both tangible and in-tangible. Some of the tangible benefits of using these tools are:

- Putting the strategic thinking process on paper in a systematic manner to revisit decisions at any time;
- Noting all the important implications of a statement or goal in question with varied inputs through different group members;

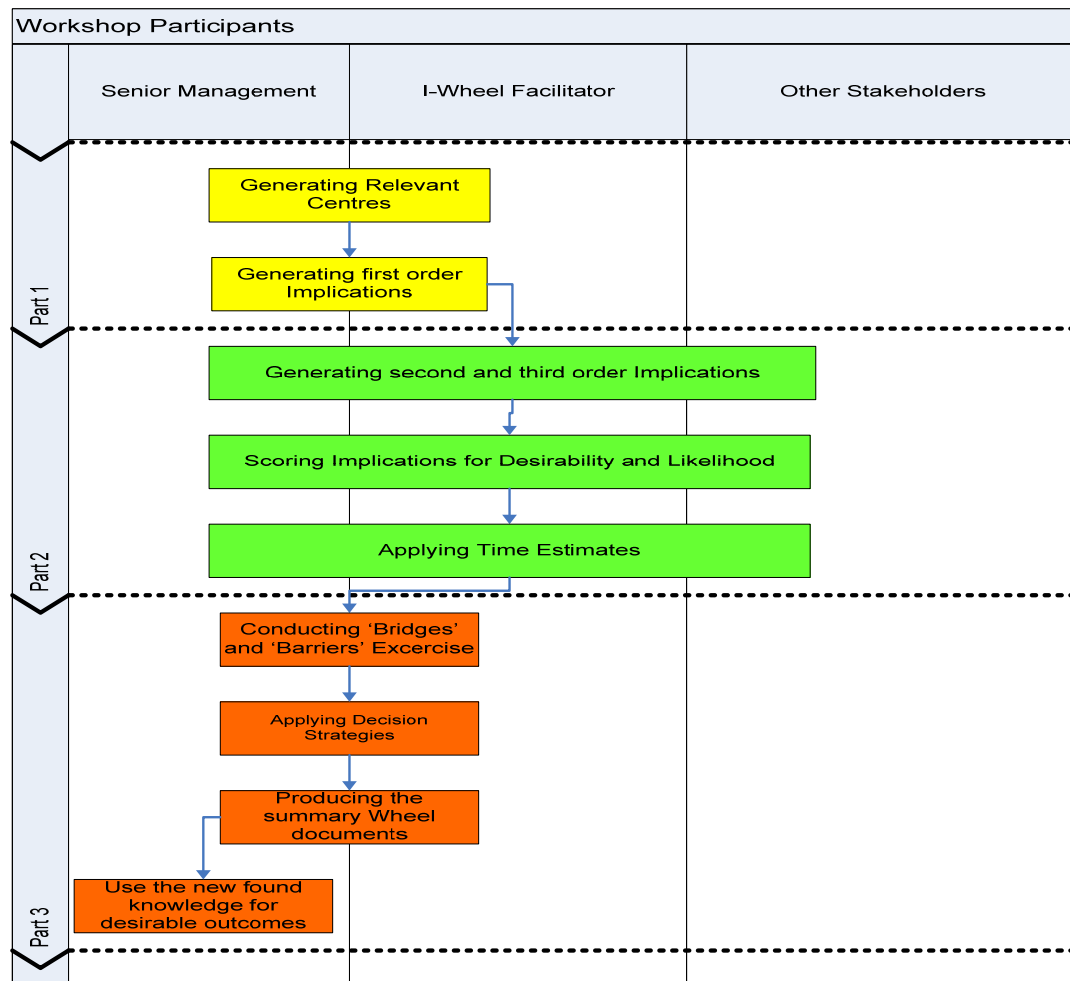

Fig 1: The Implications Wheel Process

- Providing an audit trail for the strategic decision making process;
- Speeding up decision making by early identification of the positives and negative consequences that must be dealt with as part of the specific change;
- Assisting in identifying pathways to correct an underperforming course of action;
- Scoping alliances by quickly understanding the future implications or organisation collaboration, prior to detailed implementation.

*In-tangible benefits are:*

- Leadership can use patterns found in the specifics of an I-wheel document to better anticipate organisation or market wide reactions to the change under consideration;

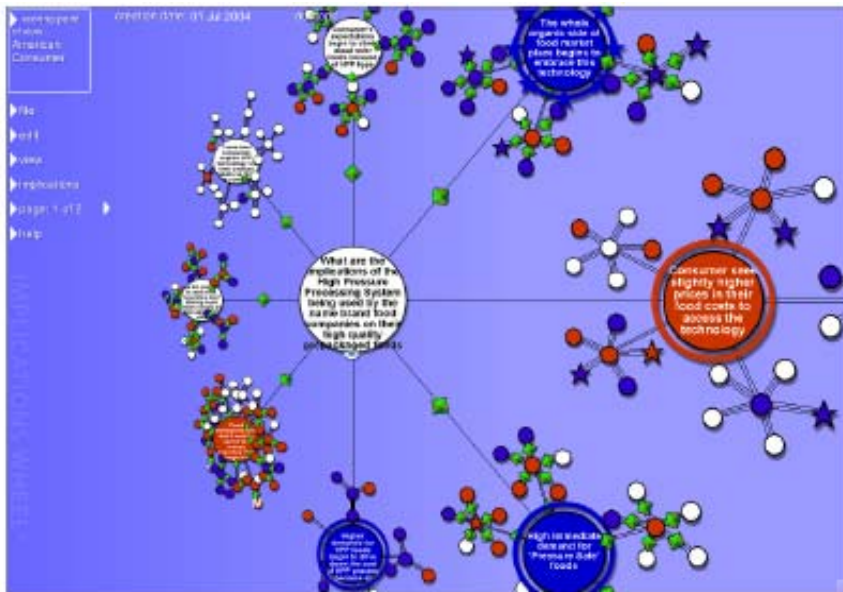

Figure 2: The Implications Wheel

- Patterns in I-wheel help organisations identify areas where more information is required. The specificity of the implications helps organisations seek this information efficiently, making good use of research resources and experts' time;
- It has a powerful impact in communicating major points to the audience, it visually illustrates the thorough examination of the long term implications, demonstrates a balanced thinking process, and highlights the main conclusions to the audience;
- It prepare organisations for strategic alliances; and
- It can be a research tool early in the process of exploration and forecasting

*Limitations:* These are

- An I-wheel workshop is best held in a group of 10-20 participants;
- It is resource intensive in terms of staff time and associated costs;
- The tool is best used when it is revisited periodically to see which course the organisation is following. This is not always possible as it involves senior management;
- It looks at each of the implications as a stand-alone but there can be a combination of implications happening, resulting in something not expected or exponentially increasing the implication of something else happening

**Resources Used:**

I-Wheel workshop for VEN International, 10<sup>th</sup> Oct, 2006, Sheffield

I-Wheel brochure

### Target Costing

**Overall aim of the Tool:** Target Costing is primarily a philosophy of cost management. The aim of Target Costing is to reduce the inherent risk of a new product development through intelligent cost management. The process is intimately related to the design and development cycle for new products or services.

**Key Features of the Tool:** The Target Costing process is complex and multi-faceted and is driven by six key elements:

1. Price Led Costing – A target costing system sets cost targets by subtracting the required profit margin from the competitive market price.
2. Customer Focused – Customer requirements for quality, cost and time are simultaneously incorporated in product and process decisions and also guide cost analysis.
3. Design Catered – Costs are designed out of products and manufacturing process by eliminating expensive features that customers do not value and by delivering the same functionality through less expensive process.
4. Cross Functional – The target costing teams consists of members from inside and outside of the organisation and are responsible for a product from initial concept through production.
5. Life Cycle Orientation – Target costing considers all costs or owning a product over its life, such as purchase price, operating costs, maintenance and repairs, and disposal costs.
6. Value-Chain Based – The cost reduction efforts are distributed throughout the value chain by developing a collaborative relationship with all members of the ‘extended enterprise’.

**How to use the tool and processes involved:** The process involved in successfully implementing Target Costing in an organisation can be divided into eight core sections: 1) Obtain Mandate for Target Costing, 2) Build Support, 3) Target Costing Pilot Project, 4) Develop an Implementation Plan, 5) Form Teams, 6) Provide Training, 7) Acquire Tools and Data and 8) Institutionalize Target Costing. These core stages help in transforming an organisation from a normal organisation to one with Target Costing practice.

Once the philosophy of Target Costing is understood and the above mentioned processes are followed, specific tools will be required for achieving the Target Cost. These tools are based on the idea of a product development process. A product development process can be described as a transformation of raw materials or data into a new product or service. Figure 1 describes this process along with some of the tools that can be used during this process stages.

In addition to the tools mentioned above in the figure, the organisations may also require some supporting tools to carry out Target Costing as well as other business functions; they are mentioned in table 1.

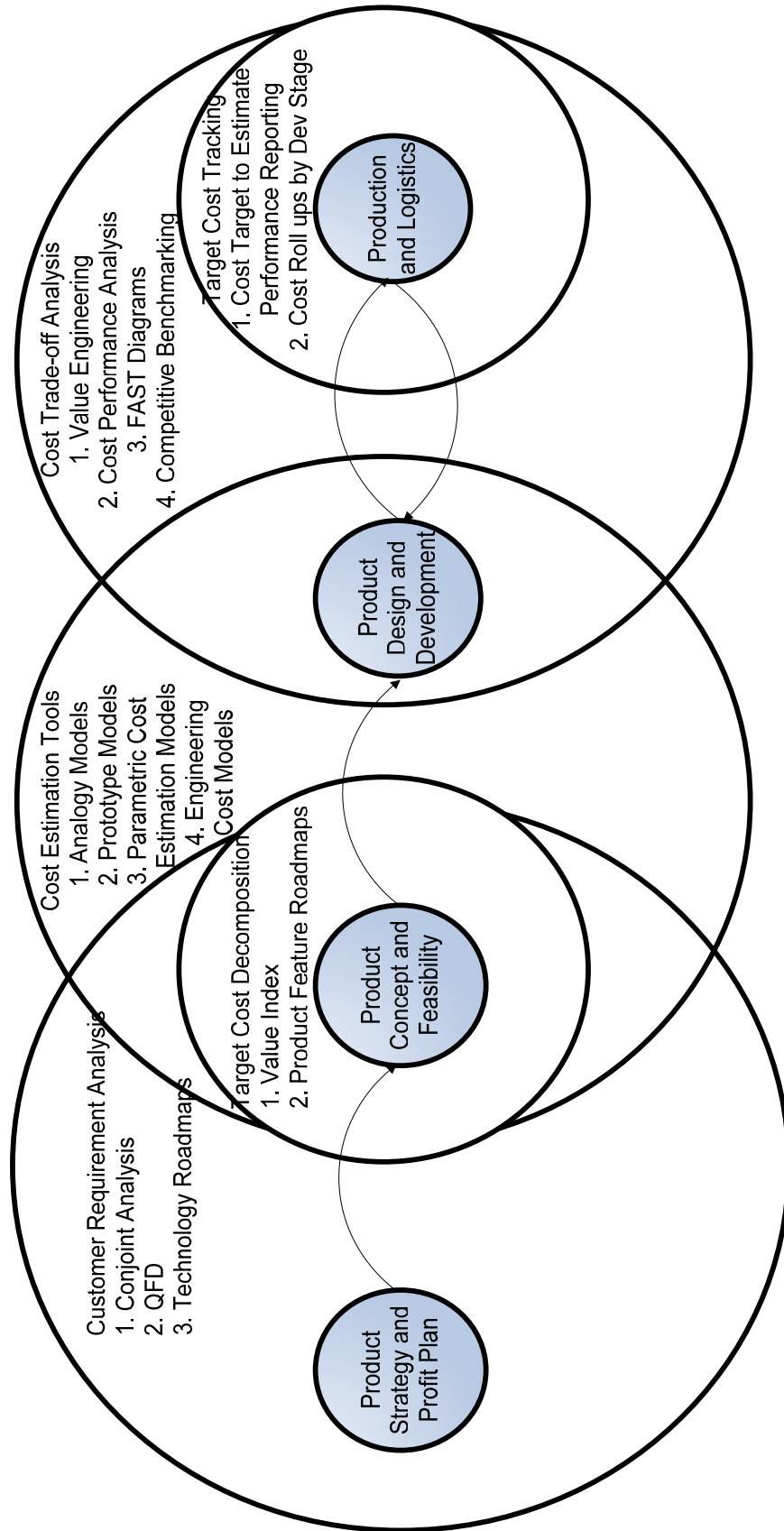

Figure 1: Product Development process and Target Costing Tool

Table 1: Support Tools for Target Costing

General Business Support Tools	Budget Planning & Management	Multiyear Product and Profit Plans
		Product Portfolio Planning
		Capital Budgeting
		Program Management
		Capacity Analysis Tool
Risk Analysis	Monte Carlo Simulation	
	Decision Trees and Real Options	
Tools Supporting Product Process Strategy	Supply Chain Management	Supplier Specific Cost Models
		Supply Chain Logistics Analysis
		Make v Buy Decision process
	Manufacturing Process Planning	Lean Manufacturing Modelling
		Decision for Manufacturability Analysis
		Dynamic Production Simulation
	Decision Integration Tools	CAD Feature Extraction
		Extraction Transformation and Loading
		Enterprise Application Integration
		Information Portals/ Business Intelligence Reporting
	Software Estimating	Function Point Analysis
		Project Scheduling
Software Support Tools	Spreadsheets	
	Desktop Point Tool	
	Custom Application	
	Packaged Analytic Application	

Since it is a philosophy, the actual route to be followed for Target Costing can differ from organisation to organisation.

**Benefits and Limitations:**

Benefits: The following are some of the Benefits of using this philosophy

- Inclusion of market perspective from the beginning.
- Early incorporation of Business Unit Targets.
- Making sure that products have potential for globalisation.
- Good platform for communication and coordination as everybody can subscribe to it. Here Cost Target is the common language.

Limitations: The limitations of this philosophy are summed up as follows:

- Starting from existing market prices can be dangerous as clients might be willing to trade off.
- Getting market data and prices difficult in disruptive markets.
- With radical innovation: getting the right cost is difficult.

**References:**

Ansari, S., Bell, J., Swenson, D., 2005, Hitting the Target – The Cam-I Target Costing Implementation Guide, Novus Publishing, USA.

Ansari, S., Bell, J. and CAM-I Target Cost Group, 1997, Target Costing: The Next Frontier in Strategic Cost Management, New York: Irwin-McGraw Hill.



## Activity Based Costing/Management (ABC/M)

### Overall aim of the Tool

Activity-Based Costing/Management is a philosophy of management accounting. ABC is a costing system used to allocate indirect and support costs (overheads) directly to products, customers and services. This data is used to produce product line cost information which is then used to support the following three key areas of strategic decision-making within the firm:

- The pricing of products/services;
- Changing the product/service range and mix through the promotion, demotion and discontinuance of existing lines; and
- The development and design of new products/services.

### Key Features of the Tool

Indirect costs in complex costing systems are acquired resources whose consumption cannot be specifically linked with individual products because they are shared by more than one product and/or it is not feasible / worthwhile to establish a system to monitor their use. If products are to be costed in manners which reflect their actual consumption for resources then their share of overhead must be absorbed by them on the basis of these activities. This view was termed 'activity-based costing' and primarily used to analyse decisions such as pricing, product mix and product sourcing. The strategic value of an ABC/M system is that it can provide useful insight into decision-making processes because it not only supplies financial data, but examines processes and activities to identify value-added and non-value added activities. The ABC/M system examines activities across departmental boundaries and forces managers to think about business processes and change their mental 'model' of the organization. The ABC/M system fits into an overall paradigm shift that emphasizes the interconnectedness of all aspects of a firm. Figure 1 demonstrates the usefulness of ABC/M systems to operations decision-making.

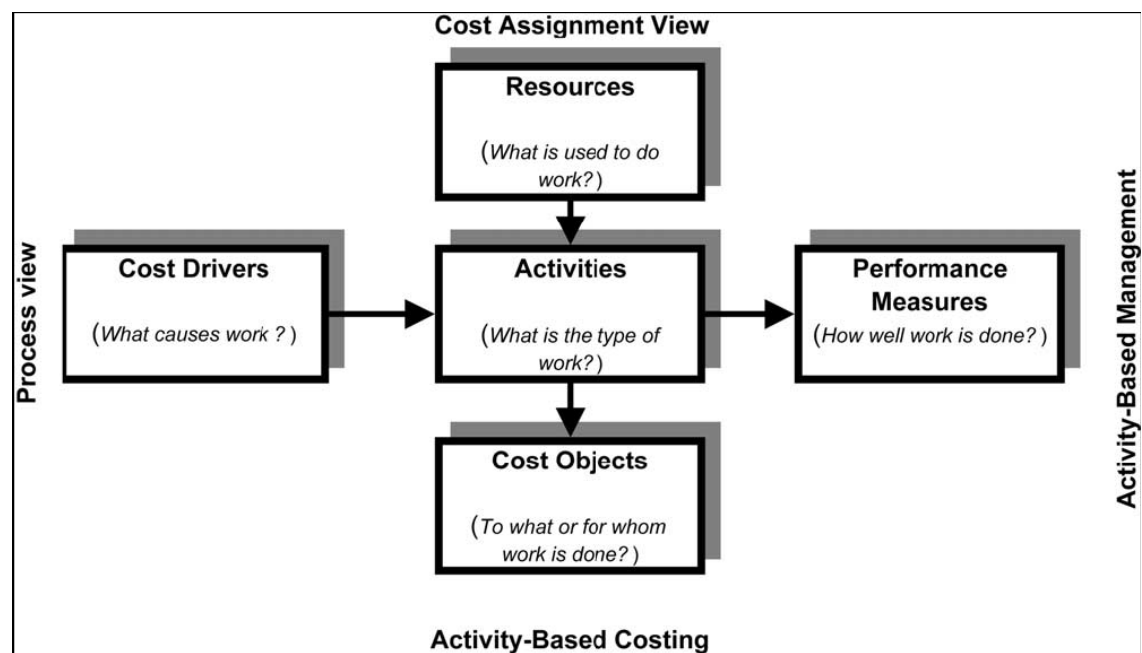

Figure 1: Activity Based costing/ Management information system (Adapted from Turney, 1992)

### How to use the tool and processes involved

The method involved in ABC analysis consists of seven stages (partly drawing on the work of Roztocki et al, 1999):

1. Identify the company's strategic objectives and key business activities.
2. Determine the overhead categories
3. Determine the percentage of each overhead category that is consumed by each activity.
4. Attach and multiply through the actual costs for these overhead categories to determine overhead spend per activity.
5. Determine product and customer activities.
6. Determine the relationship between products/activities and customers/activities in a matrix form.
7. Finally, attach and multiply through the activity costs

### **Benefits and Limitations**

Benefits:

- Provides more accurate product line costings particularly where non-volume related overheads are significant and a diverse product line is manufactured.
- Is flexible enough to analyse costs by cost objects other than products such as processes, area of managerial responsibility and customers.
- Provides a reliable indication of long-run variable product cost which is particularly relevant to managerial decision-making at a strategic level.
- Provides meaningful financial (periodic cost driver rates) and non-financial (periodic cost driver volumes) measures which are relevant for cost management and performance management assessment at an operations level.
- Provides a more logical, acceptable and comprehensible basis for costing work.

Limitations:

- Activity Based costing information is historic and internally orientated and therefore lacks direct relevance for future strategic decisions.
- Practical problems such as cost driver selection and cost communalities are unresolved.

### **References**

- Innes, J. and Mitchell, F. (1990), Activity Based Costing – A review with case studies, The chartered institute of management accountants, London
- Turney, P.B.B. (1992), Activity-based management, Management Accounting 74 (January), 20–23

### **Partnering Intelligence with Partnership Continuum Model**

**Overall Aim of the tool:** The aim of this tool is to provide insights into the human attributes and dynamics that make individuals successful partners through the Partnership Continuum model, which helps groups of people to create successful partnerships.

**Key Features of the tool:** Partnering is a management strategy and an executive competency. The important features of the tool are the assessment of the six important attributes required for building a successful partnership. Each of the partners should be adept in all these six partnering attributes. The skills are designed to provide one with personal insights and competencies needed to be able to navigate through the stages of relationship development.

The second key feature of the tool is the partnership continuum model and it focuses on the stages of partnership development along with the relationship development.

Thus, improving one's Partnering Intelligence and following a deliberate and purposeful partnering process is the two crucial features of building smart partnerships.

#### **How to use the tool and processes involved:**

The tool is essentially divided into two parts.

The first part of the tool explains and helps to become a smart partner. This would help to be a better partner in the long run. And also the groups go through the stages of relationship development. These stages are predictable stages and help as steps in a cycle people use to determine trust and move from scepticism to performance. The six partnership attributes help the partners move through this cycle more efficiently and successfully.

The first step for the tool is using the Partnering Quotient Assessment to measure the Partnering Intelligence of the team members. This validated instrument provides us with a "raw PQ score" and then breaks the score down based on the six partnering attributes. The six partnering attributes are the critical skills that build an environment of trust. Partnerships are organic in nature and thus are nurtured or threatened by the atmosphere in which they live. Each of the six partnering attributes is an element in that atmosphere.

Understanding and becoming adept in the use of the six partnering attributes forms the second step in using this tool. Once PQ assessment is completed, based on the scores, one can start by tackling the weakest first, and then move to those areas in which one has strengths to reinforce the way in which relationships are formed.

The third step in the tool is the actual use of the Partnership Continuum Model. As shown in the figure below, the model comprises of two components. The stages of relationship development – Form, Storm, Norm and Perform – describe the processes individuals need to go through to build trusting, mutually beneficial relationships. The stages of partnership development – Assess, Explore, Initiate and Commit – describe the tasks that partners must accomplish to create a successful partnership.

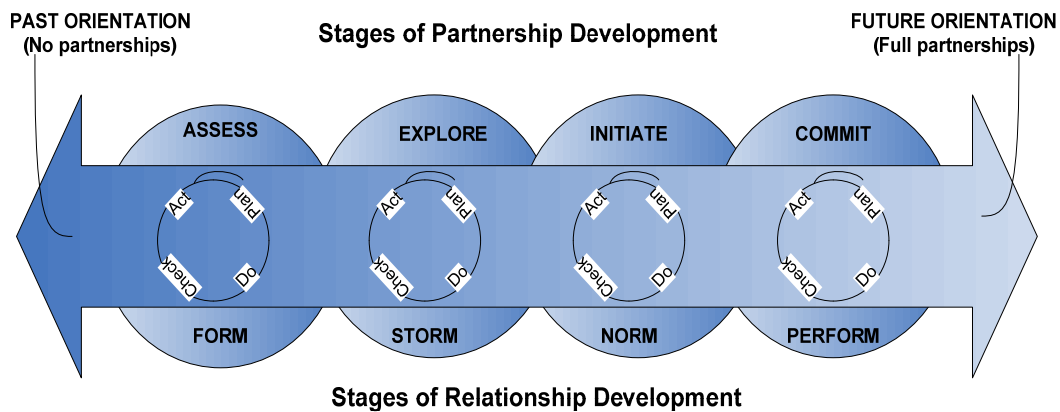

The stages inside each of these stages of Partnership are developed into flow chart and represented as below. Each of the sub-stages inside the stages of Partnership Development is performed with the help of different assessments thus providing a roadmap for creating partnerships. The flow charts above describe the sub-stages of each of them.

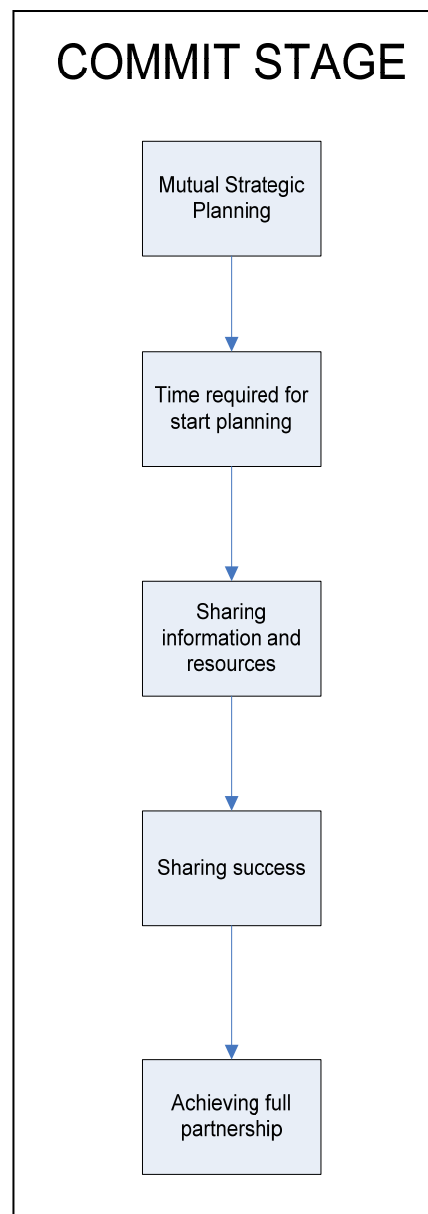
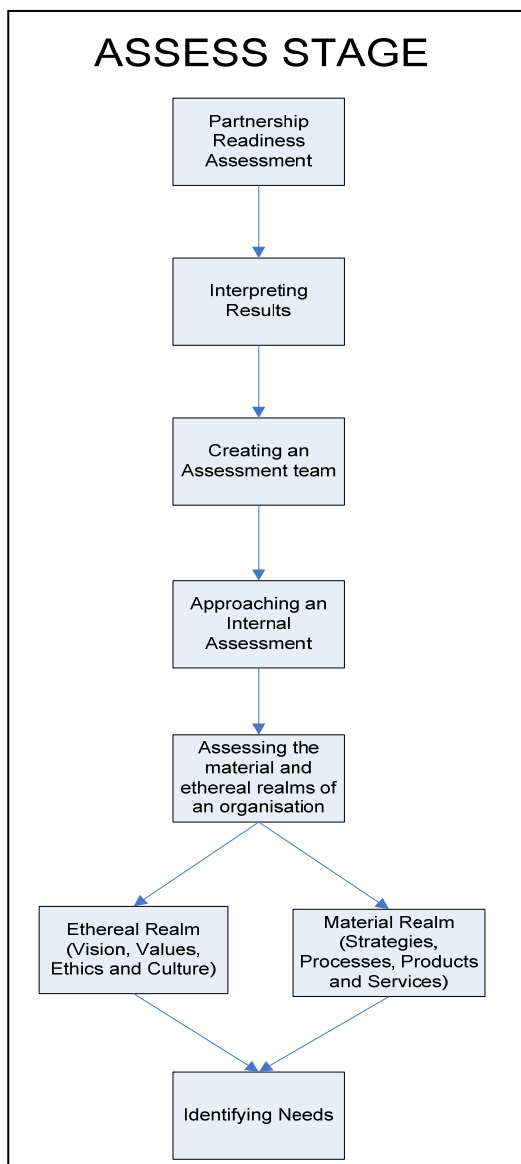

**Benefits and Limitations:**

Benefits – The benefits of using this tool are prominent from the point of view of gains made to prepare a person, a team or an organisation to partner with another such person, team or organisation. It essentially covers all the important components to make a partnership work which can be stated as follows:

- Active support of leaders
- Appropriate team membership with equal participation
- Common objectives
- Clear boundaries and scope
- Consensus and openness
- Trust and mutual benefit.

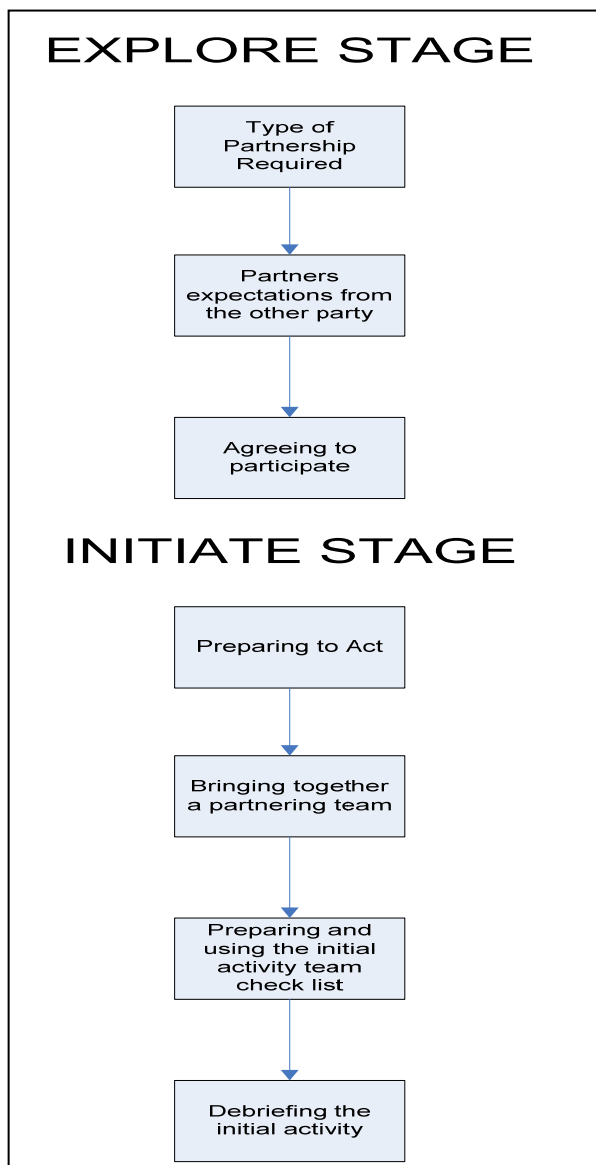

Limitations –

- The tool is of immense help once the firm realises the importance of partnership but it doesn't help in pointing out the need for partnership at a particular juncture for a particular organisation.
- The tool does not cover the legal aspects of the partnerships.
- The tool essentially asks to spend a lot of time developing partnership which is not always available for fast track projects.

**Reference resources:**

Dent, S.M., 2004, Partnering Intelligence, Davies-Black publishing, California  
 Dent, S.M., Naiman, S.M., 2002, The Partnering Intelligence Fieldbook, Davies-Black publishing, California



---

## Value Management (VM) Framework

### Overall aim of the Tool

The aim of this tool is to define and present a framework for the VM process and provide an outline for use on projects. The framework is to be considered the benchmark, a frame of reference based on current international practice of VM, to be used by practitioners and clients alike.

For this framework, VM is defined as a proactive, creative, problem-solving and problem-seeking service which maximises the functional value of a project by managing its development from concept to use. The process uses structures, team-oriented exercises that make explicit and appraise existing or generated solutions to a problem by reference to the value requirements of the client, making use of the package of benefits a client requires at an appropriate cost.

### Key Features of the Tool

The Value Management Framework (VMF) presents a framework for undertaking the VM process on projects, primarily in the construction industry. However, as experience has also been drawn from the manufacturing sector, large portions of this VMF may also be applicable to other industries.

The VMF has been developed to be generic in nature and as such, individual project procuring clients and VM practitioners must adapt the framework presented to meet their specific organisational and project needs. The VMF contains the important steps in the VM process and also the requirements at specific points where there can be value generated in the project life cycle.

Figure 1 describes the generic VM process, which is structured around the 'Job Plan' under eight headings. A VM workshop forms part of the overall process. The figure also describes what each of these eight headings of VM process consists of.

### How to use the Framework and Processes Involved

The generic VM process can be broken down into two major areas:

- Value opportunities throughout the project life cycle – possible intervention points
- The inputs to and outputs from the VM workshop – the process.

The generic VM process, mentioned in figure 1, is practiced at five key value opportunities where the process could be employed to achieve maximum effect on any project during its life cycle. These are:

1. The Pre-Brief Workshop – the identification of the client's value system and project mission. This ensures the project mission's strategic fit with the corporate objectives of the client organisation (A decision to construct).
2. The Briefing Workshop – undertaken after the appointment of the project team. The objective of the workshop is to specify the client's requirements in the context of the client's value system and the project mission.
3. The Outline Sketch Workshop – undertaken following the project team's interpretation of the brief expressed. (Workshop preceding application for detailed planning consent).
4. The Final Sketch Design (FSD) Workshop – undertaken once sketch design is complete but prior to the commencement of final sketch design. This workshop will audit the design against the brief and will address element and component issues.
5. The Operations Workshop – undertaken after the appointment of and including the contractor and key specialist sub-contractors. This workshop will address 'constructability' and supply chain issues.

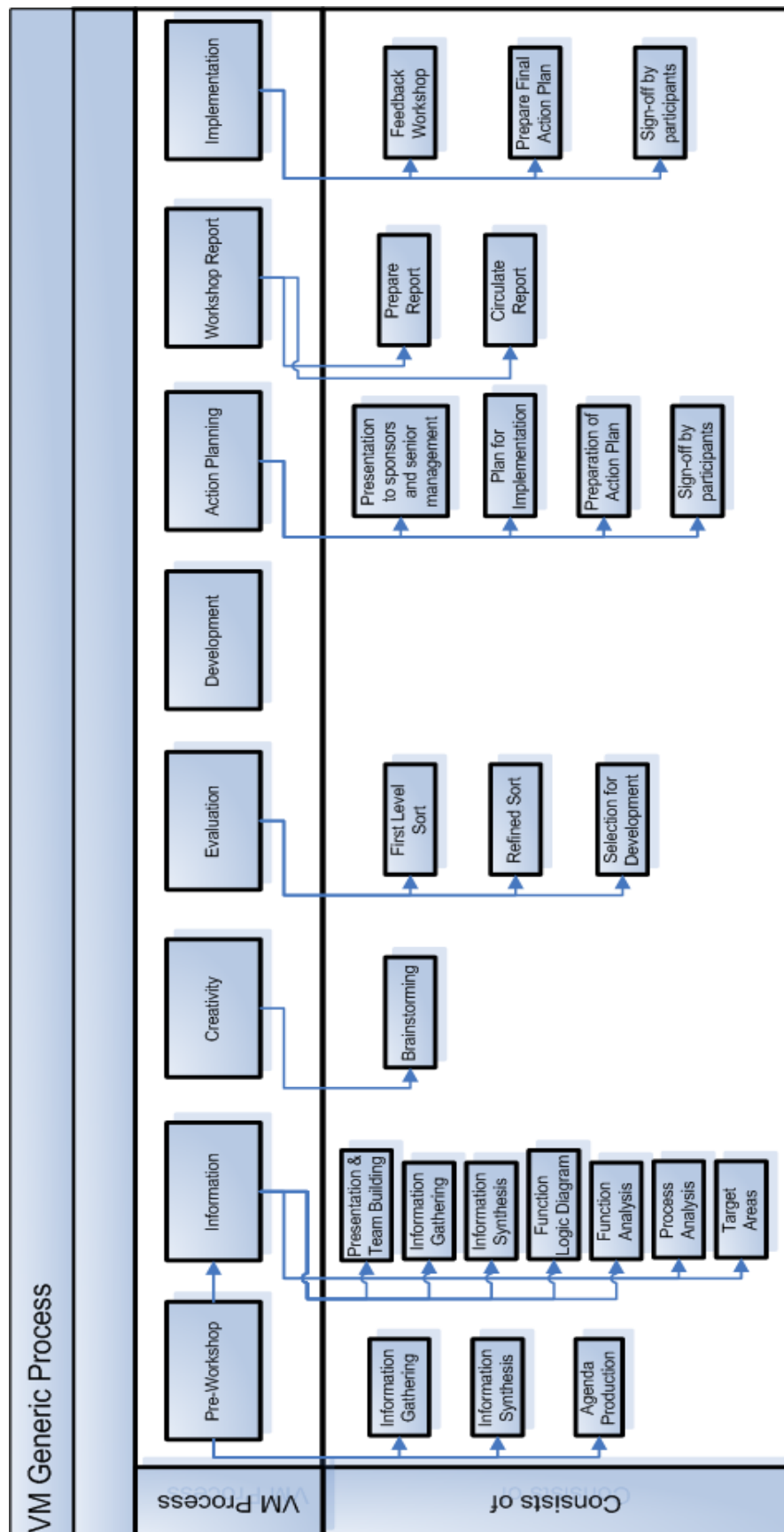

Figure 1: Generic VM process (Based on VM process figure in Male, Value Management Framework CD)



VM can take place at any point in the project life cycle and the number of VM opportunities can vary from project to project. For each of the eight VM processes, there are many tools available to be used and according to the type of the project, the workshop participants and the workshop agenda different tools can be used.

### **Benefits and Limitations**

#### Benefits:

- The primary reason for any client commissioning a VM study is to achieve value improvements and/or monetary savings on the project under investigation to ensure value-for-money.
- VM workshops can be extremely useful for team building. The workshop provides an environment for accelerating the gelling of the team and mutual understanding. It forces the participants to open up and commit themselves to the process of value management and to the project itself.
- VM workshops have a tendency to allocate responsibilities to a greater degree than is usually the norm. People are made accountable for various parts of the project under investigation.

#### Limitations:

- It's not always easy to allocate the time resources of senior management from all the concerned parties for a VM workshop particularly on a single day at a particular place.
- Lack of senior staff commitment to such workshops may lead to project teams not taking it seriously.
- VM workshops deals with intangible parameters of a project and thus it is hard to measure the success rate of such a process.

### **References**

S. Male, Value Management Framework CD, 2001, Harriet-Watt University and Leeds University



## APPENDIX E – PRELIMINARY CASE STUDY QUESTIONNAIRE



### Preliminary Case Study Questionnaire

This questionnaire is a part of a research programme at Loughborough University aimed at enhancing the value of CW working within a case-study organisation (ServQ Limited). The preliminary case study aims to investigate the current collaborative working arrangement of ServQ, along with its successes and barriers according to the collaborators and Directors of ServQ. It is a semi-structured interview and hence the questions are more used as a guidance to extract the related information while giving the flexibility to the respondent. The responses would be treated with the strictest of confidence and would be used only for academic purposes.

#### 1. Background Information

- 1.1. Name of the interviewee.....
- 1.2. Designation in ServQ.....
- 1.3. Associated with ServQ since.....
- 1.4. Skills/Expertise.....

#### 2. Collaboration Practices of ServQ

- 2.1. How would you describe the collaborative arrangement of ServQ?

.....

- 2.2. Explain the involvement of collaborators in pre-project and post-project phases.

.....

- 2.3. What are the arrangements to encourage collaborators into the daily working of ServQ?

.....

- 2.4. How often ServQ and its collaborators meet each other to discuss future course of actions (i.e. Strategy workshops)?

.....  
.....  
3. Enablers and Barriers

3.1. What are the successes of the current collaborative working arrangement of ServQ?

.....  
.....  
3.2. What are the barriers to the current collaborative working arrangement of ServQ?

.....  
.....  
3.3. Describe the audit/review processes to ensure feedback from stakeholders at the end of each consultancy projects.

.....  
.....  
4. Information Transparency

4.1. Can you please tell us the tools and techniques available with ServQ?

.....  
.....  
4.2. Describe your knowledge of each of these ServQ tools.

.....  
.....  
4.3. What areas of consultancy these tools cover? i.e. diagnosis, BPR, etc.

.....  
.....  
4.4. Do you see any areas not covered by these tools?

.....  
.....  
4.5. Who owns IP (Intellectual Property) at the end of projects?

.....  
.....

## APPENDIX F – COLLABORATION CHARTER FOR SERVQ



### Collaboration Charter

Adopted October 2008

#### **Introduction**

**ServQ** means **S**ervice and **Q**uality; and our business is based on achieving both of these values. ServQ connects with a group of associates and strategic partners through its collaboration efforts. These Associates and Strategic Partners consist of international managers, advisors, authors and experts in the fields of Strategy Formulation, Organisational Alignment, Partnering & Alliancing and its implementation.

#### **Vision**

The vision of ServQ's collaboration is to build a world class management and advisory business.

#### **Mission**

The mission of ServQ is to be the best business partners of our clients and associates and go beyond the normal task oriented threshold to establish long term, positive and trusting business relationships.

#### **Goal Setting**

We believe our associates and partners are our human capital and thus our key assets. The success of our business hinges on the diverse work experience of our professionals, which enables us to give value added solutions to our clients. We appreciate the importance of a thorough understanding of our associates' and partners' business issues and expectations. This leads to long standing sustainable business collaboration.

As part of that understanding, we would ensure that both ServQ and the prospective associates articulate their priorities and align goals to create a win-win situation for both parties. This will help us respect each other's viewpoints, experiences and our differences. We also believe that priorities and goals are dynamic in nature and thus, they may change with time. We will revisit them at periodic intervals to ascertain that our overall aims are still compatible and we are maximising the benefits.

### **Commitment to Collaboration**

We are fully committed to our associates and strategic partners. As part of that commitment, all parties are encouraged to buy into our common and shared culture that we achieve by:

- Applying ServQ's **Process Protocol** at all times to sustain long term collaboration. This protocol guides the conduct of the parties during the pre-project, project and post-project phases. This document is dynamic and flexible by nature and subject to continuous improvement.
- **Open Communication** is strongly encouraged since ServQ and associates maybe geographically dispersed. We promote regular two way communication through emails, phone calls or in person. While email may prove helpful for sharing information, resources or documents, some communication is more effectively handled by meeting in person. Our strategies for open communications include sharing of resource space on ServQ's Intranet, periodic publications and face-to-face formal and informal meetings.
  - All ServQ associates and strategic partners are given access to ServQ's Intranet and we encourage our associates to contribute to the collaboration's body of knowledge (examples such as on-line articles, publications, discussion forums, IP development and enhancement).
  - ServQ will ensure periodic newsletters are made available to all the associates and strategic partners outlining the current projects carried out by the collaboration, information about any new associates or strategic partners joining, possible projects in the pipeline, latest IP development and articles by the associates. Although not mandatory, ServQ encourages atleast one article from each associate every year, talking about the latest projects carried out by the associate.
  - ServQ understands the need for periodic face-to-face meetings and networking events between the associates to further develop the collaboration. ServQ will arrange atleast one informal get-together each year and will anticipate substantial participation by the associates.
- We are committed to developing and further enhancing the core competencies of our associates through **Training and Development**. In order for a degree of equitability, ServQ may require the Associate to contribute to specific training

and development initiatives. Such sessions may be combined with the informal meetings to ensure greater participation.

- All the stakeholders in the collaboration reap the benefits of new projects and it is therefore necessary for associates to be active in **Marketing** as well as **Tendering** processes. All marketing and opportunities need to be logged within the company's prospects database and the progress towards conversion be kept up to date in a timely manner. This communication and audit trail helps ServQ determine appropriate bonuses and rewards – it is therefore mutually beneficial. The marketing strategy will be jointly developed and executed by parties to get mutual benefit.

**Confidentiality**

ServQ and its associates both have access to and develop significant Intellectual Property (Foreground and Background) and have access to Client information before, during and post assignments. The protection of this is paramount and subject to confidentiality undertakings. In signing this charter the Associate acknowledges this fact.

**Review of Collaboration Charter and Agreement**

Following a 3-month period of probation, this charter as well as the Agreement shall remain in force for a period of **four** years unless terminated by one or other party giving six months notice of intention to terminate in writing. This charter and Agreement shall be reviewed by the parties annually.

Signed

..... On behalf of ServQ Limited

Date.....

And

.....Associate

Date.....

The following is a partnership agreement in support of the collaboration charter. It covers the finer points not covered in the charter and further clarifies some of the points mentioned above.

### **Partnership Agreement**

This Agreement of \_\_\_\_\_ defines the relationship between

And

ServQ Limited (*ServQ*)

Regus House

Malthouse Avenue

Cardiff Gate Business Park

Cardiff

CF23 8RU

The Associate has skills and experience of the partnering, value management and performance improvement processes, and wishes to take those capabilities to the market place in association with ServQ to the extent and in the manner defined in this agreement.

And

ServQ wishes to identify, win and deliver work in partnership with the Associate and has an infrastructure, product range and product development philosophy which will facilitate a mutually beneficial relationship.

- 1) The reward structure for the Associate will be based upon a table of remuneration, which will be published on the intranet, and updated periodically. The link between fee income, associate reward and other costs will be clearly shown. The table will express an expected level of remuneration for each grade, and is subject to the following:
  - An equitable charge band/grading is maintained commensurate with relevant skills and experience (Grade 1 to 5 plus admin support grade);
  - Travelling time is excluded from fee calculations unless specifically agreed otherwise;
  - Rates are subject to final written agreement on a project-by-project basis, and may by such agreement be higher or lower;
  - ServQ will explain the reasoning behind any such changes (normally market related);



- 
- Project-related expenses are refunded at cost, in line with client project arrangements;
  - Expenses are refunded at cost for overhead work where they relate to pre-agreed activities and budgets;
  - Client time relates to work carried out for a Client as part of a specific engagement from ServQ;
  - Overhead work relates to specific tasks proposed by ServQ and accepted by the Associate, which contribute to the overall development of ServQ as a business;
  - Business Development activity is not classed as overhead work – the reward for successful business development work is via a bonus pool arrangement that is published / reviewed from time to time;
  - Work winning bonus will be paid to the Associate from this pool in proportion to, and allocated by ServQ, on the basis of contribution to the work winning and execution efforts by all participants in the process. Payment of this bonus is made pro rata to the Client fee payment profile and quarterly in arrears;
  - For Associates working on projects, part of the bonus pool is retained and paid subject to successful completion of a project - as determined by the Client and ServQ. Allocation will be pro rata to the input of each participant;
  - Project and overhead payments are made in line with project cash flow or monthly in arrears against invoice from the Associate;
  - At its sole discretion ServQ may make bonus payments to Associates following the completion of the annual accounts.
- 2) The Associate is free to continue to carry out work in his/her own right, where the work done either predates this agreement, or where the nature of the work does not lie within ServQ's product/services portfolio. The Associate is expected to keep ServQ informed on availability, preferably via the company's intranet/diary and with regular dialogue. Access to the appropriate levels of the ServQ intranet will be granted after signing the agreement.
  - 3) ServQ and the Associate agree that work which lies within ServQ's product range shall be offered to existing Clients of the Associate under the ServQ banner.
  - 4) ServQ may at its sole discretion offer to the Associate the opportunity to participate in or take option over part of the equity of ServQ or of its subsidiaries and Joint Ventures. The cost of such equity investment or option shall be as determined by ServQ from time to time.
  - 5) This agreement does not establish the Associate as an employee of ServQ. The Associate shall at all times be responsible for his/her own taxation and social security payments in accordance with prevailing legislation.
  - 6) The trading relationship between the Associate and ServQ shall be strictly at arms' length. The Associate is responsible for the provision of his/her own computer equipment. This must be security and virus protected to professional standards in-line with ServQ's current IT policy.
-

- 7) The Associate may at ServQ’s sole discretion be asked to serve on the management team, as a director of ServQ or of a subsidiary. Such service shall not alter the provisions of 1 and 2 above.
- 8) The Associate shall at all times act in the best interests of ServQ and of its Clients.
- 9) The Associate shall use all reasonable skill and care at all times whilst operating as an Associate of ServQ.
- 10) The Associate shall maintain his/her own professional indemnity, public liability, motor vehicle and employers liability (where appropriate) insurances. Copies of such insurance certificates shall be made available to ServQ upon request.
- 11) The Associate shall not during the currency of this Agreement work directly or indirectly for any competitor of ServQ, save with ServQ’s prior written consent.
- 12) The Associate shall use ServQ corporate stationery and operate in line with ServQ’s branding policy whilst engaged in work under this agreement (relevant templates will be provided).
- 13) The Associate shall be properly represented by ServQ in ServQ documentation, website etc. and be granted appropriate access to the company’s on-line systems and databases
- 14) No associate can commit the company under contract, offer or similar commitment without the express approval of a statutory director. This applies to bids, tenders, offers and contracts.
- 15) Either party may terminate this agreement with immediate effect if the other party has acted in bad faith or does not comply with the letter, spirit and intent of this agreement.
- 16) Disputes shall be resolved by amicable negotiation between the parties, applying the principles established in the Partnership Continuum process. Where such agreement cannot be reached, the Parties agree to refer the dispute for mediation to CEDR in London, under CEDR rules.
- 17) The parties to this agreement agree to hold in confidence all matters pertaining to this agreement and any contracts or potential contracts arising from it, save where information is already in the public domain or where disclosure is required by a competent legal authority.
- 18) This agreement is subject to the Laws of England and the jurisdiction of the English Courts.

Signed

..... On behalf of ServQ Limited

Date.....

And

.....Associate

## **APPENDIX G – IDEF0 DIAGRAM**

### List of IDEF0 diagrams

- Node CW – Context Diagram (Level 1)
- Node A0 – Parent Diagram (Level 2)
- Node A1 – Strategize Key Sector Portfolios (Level 3)
- Node A2 – Acquire Portfolio of Tools and Techniques (Level 3)
- Node A3 – Establish Core Associates Team (Level 3)
- Node A4 – Manage Associate Team Training (Level 3)
- Node A5 – Win New Projects (Level 3)
- Node A6 – Execute Projects (Level 3)

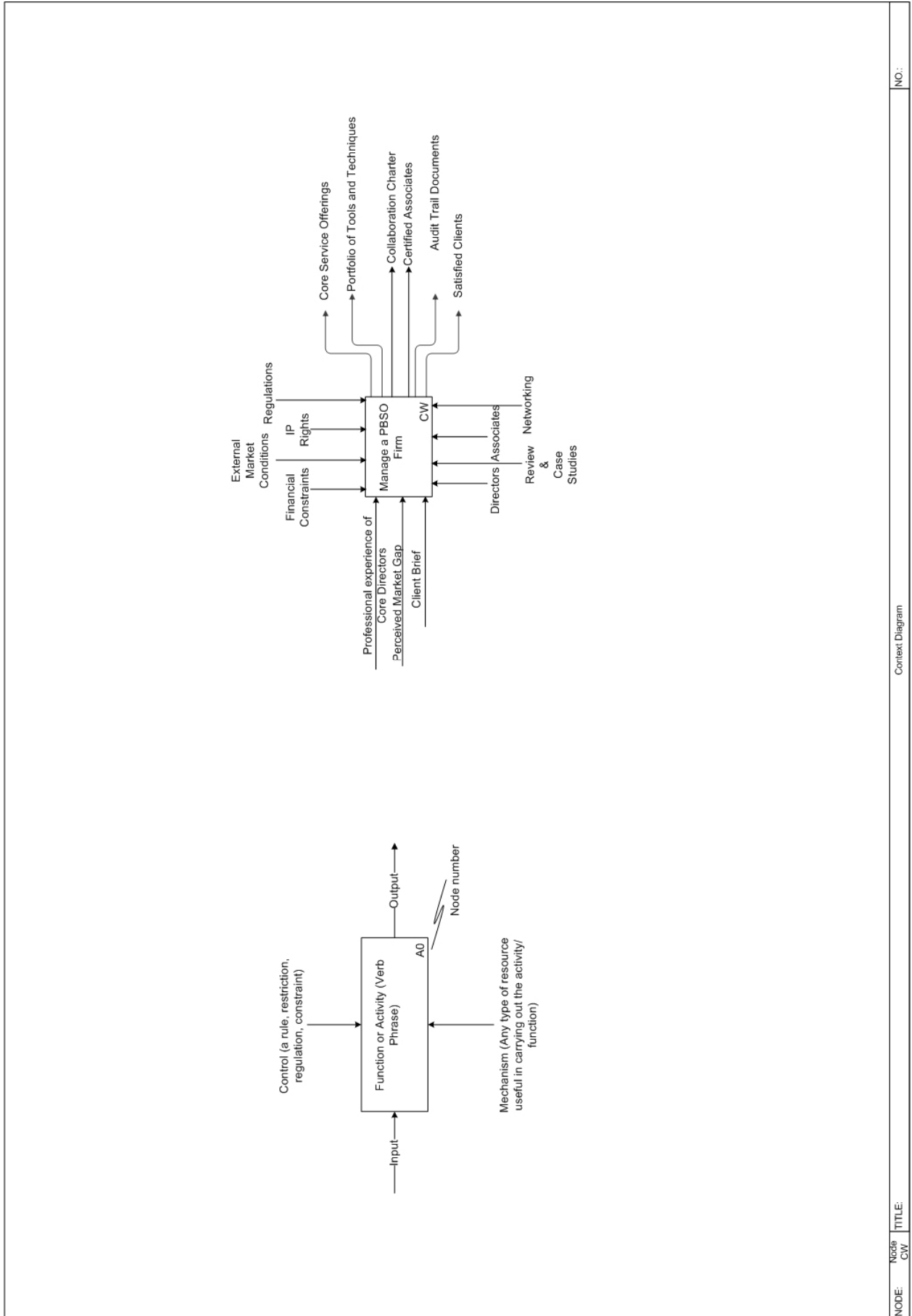

NO.:

Context Diagram

NODE: Node CW

TITLE:

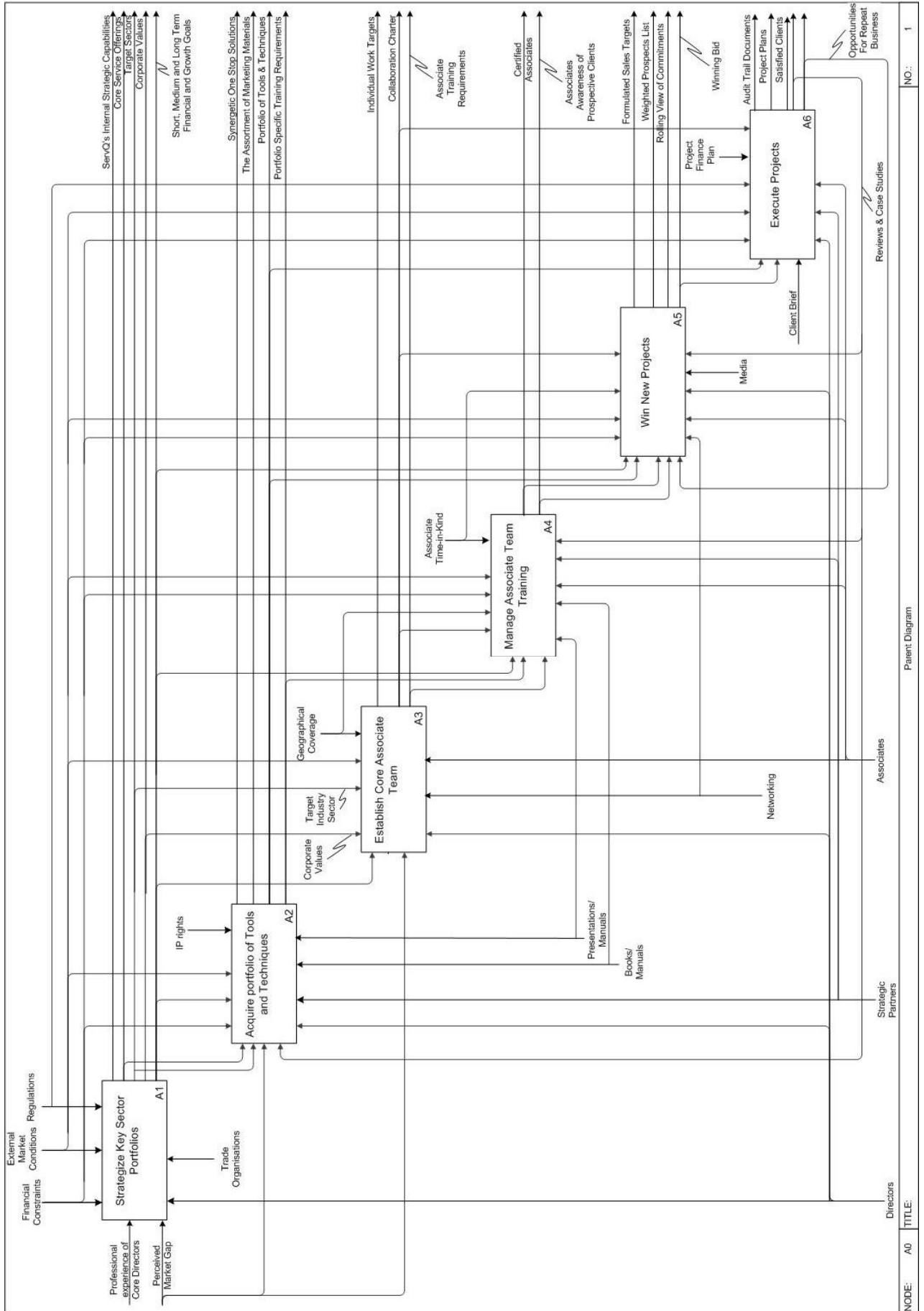

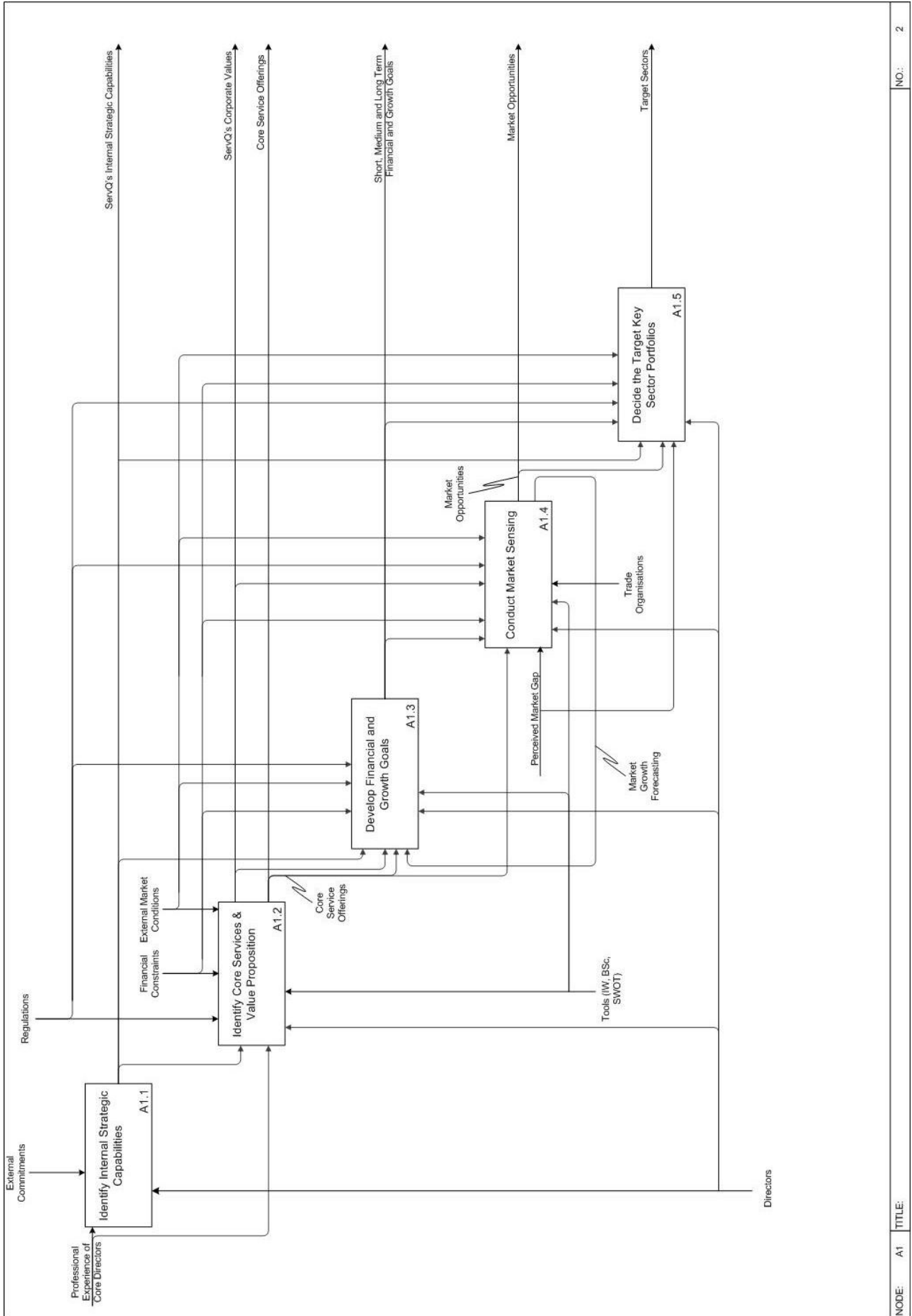

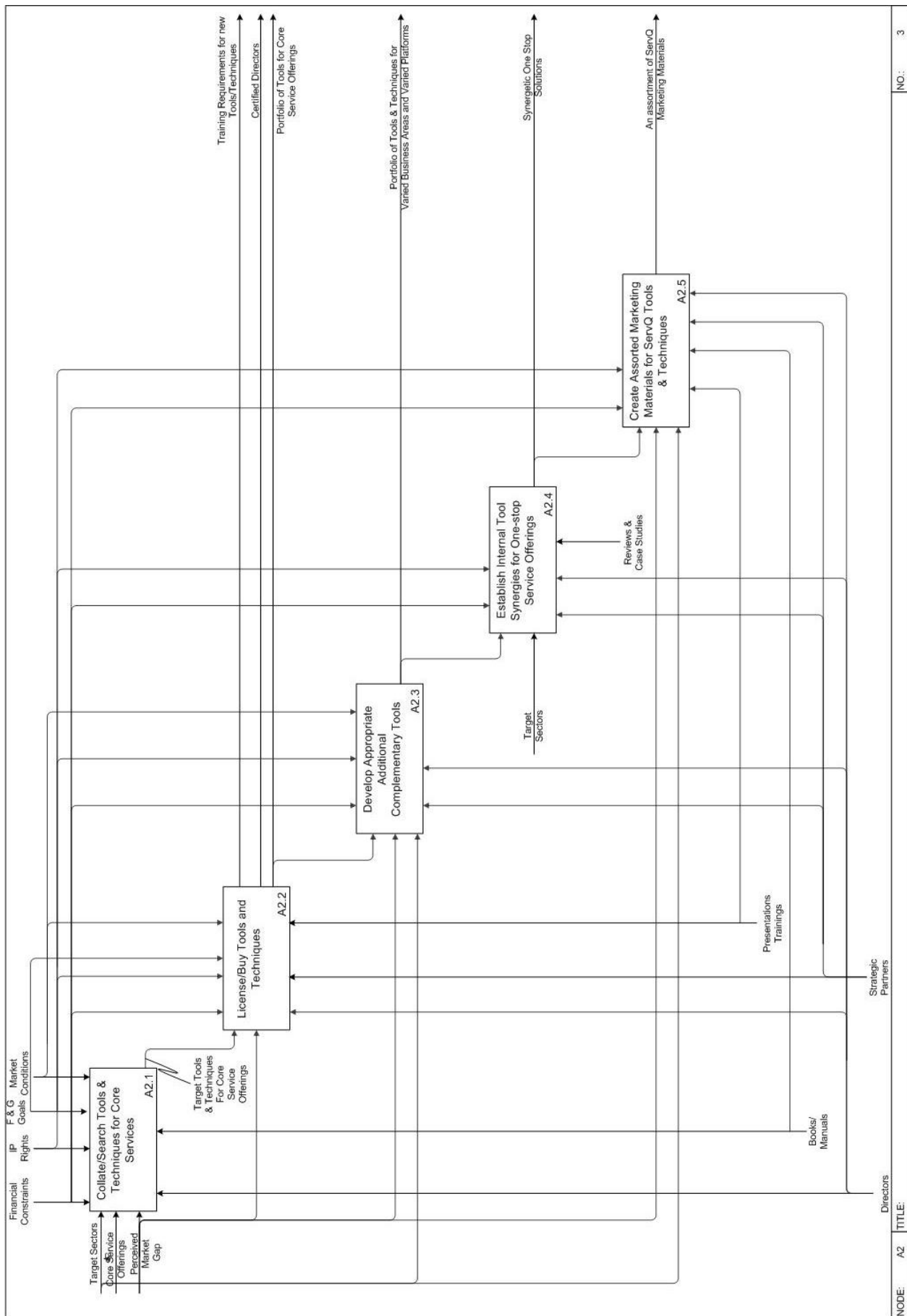

NO.: 3

Directors

Strategic Partners

Presentations Trainings

Books/Manuals

NODE: A2

TITLE:

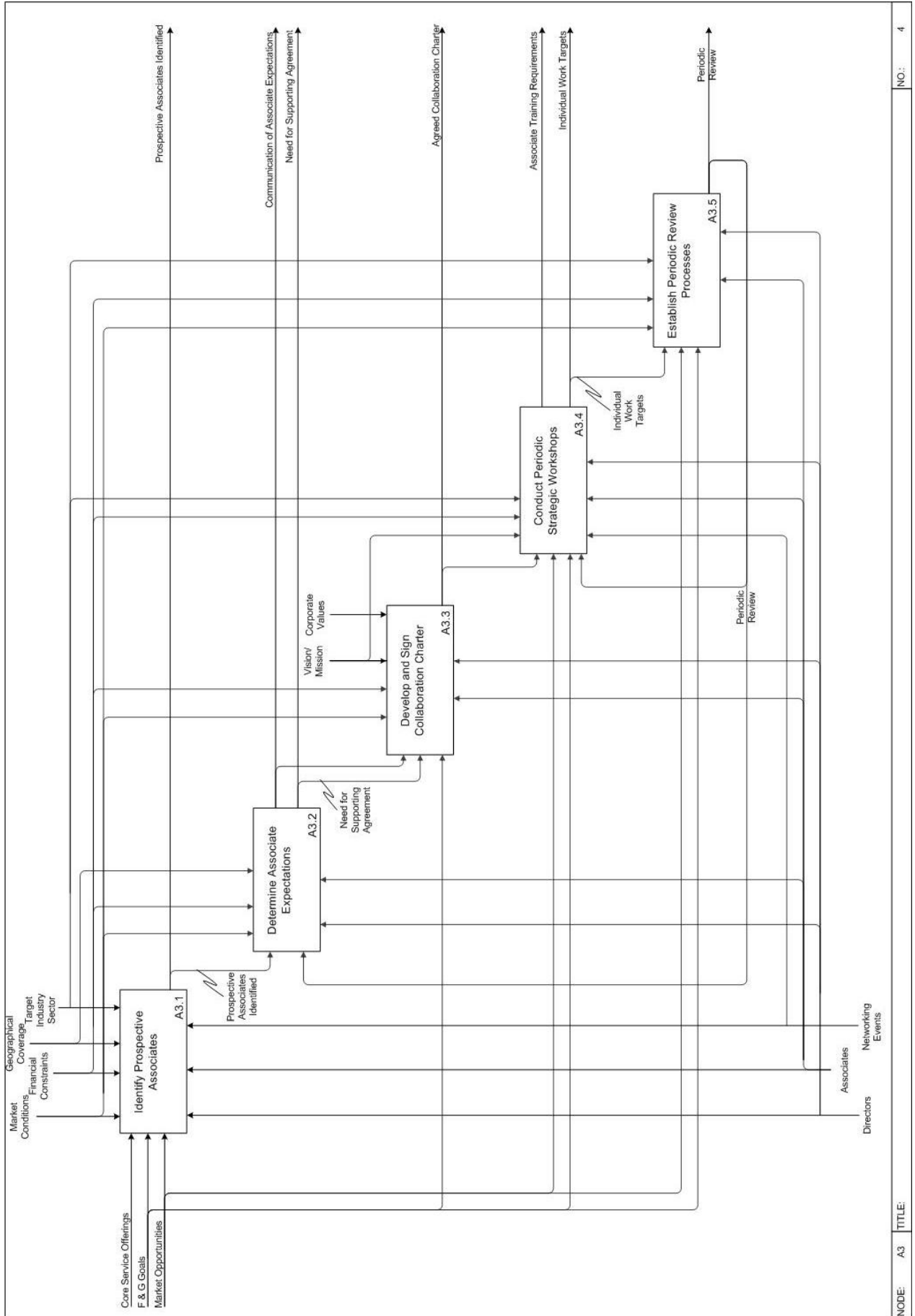

NO: 4

NODE: A3 TITLE:



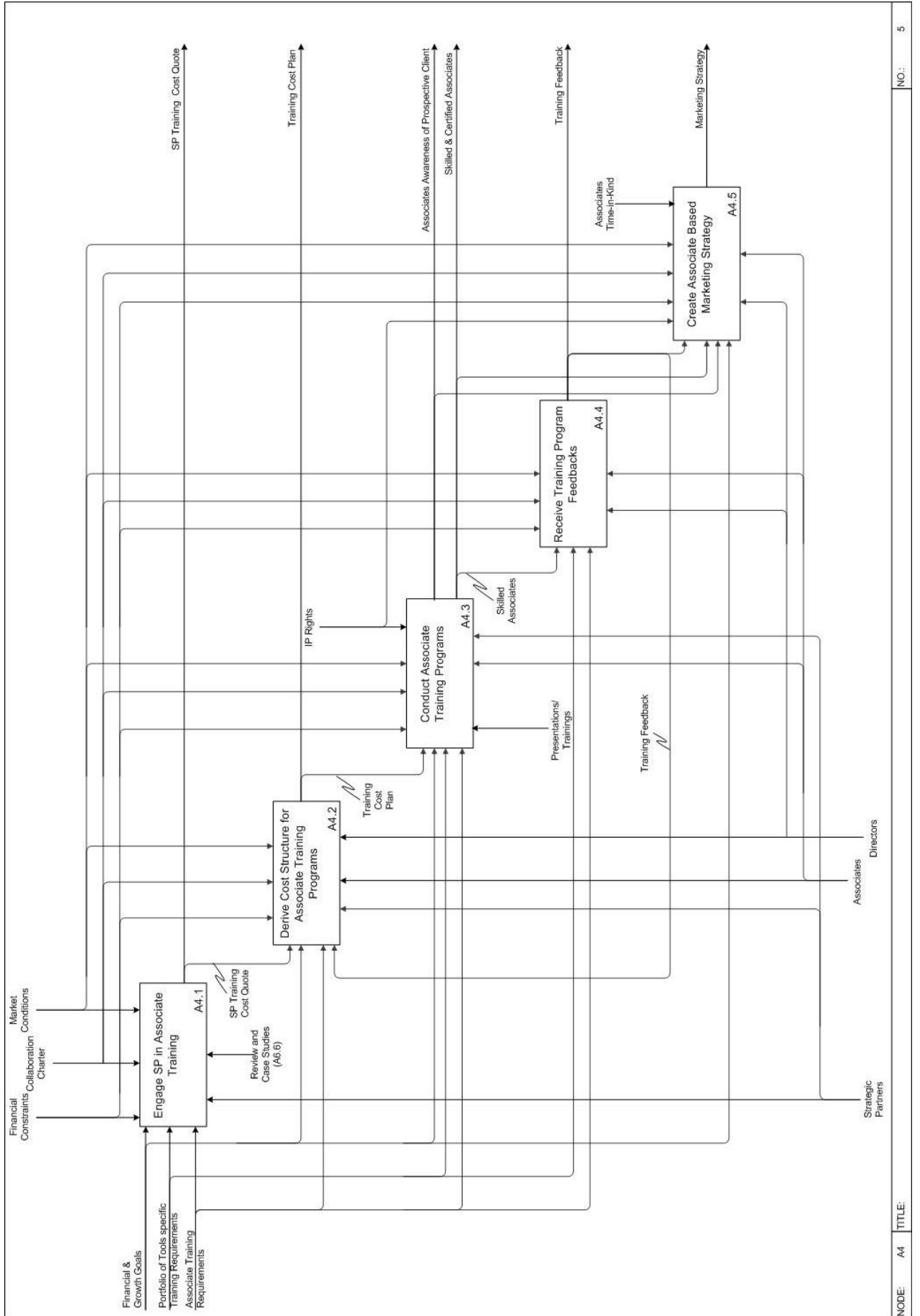

NO.: 5

NODE: A4 TITLE:

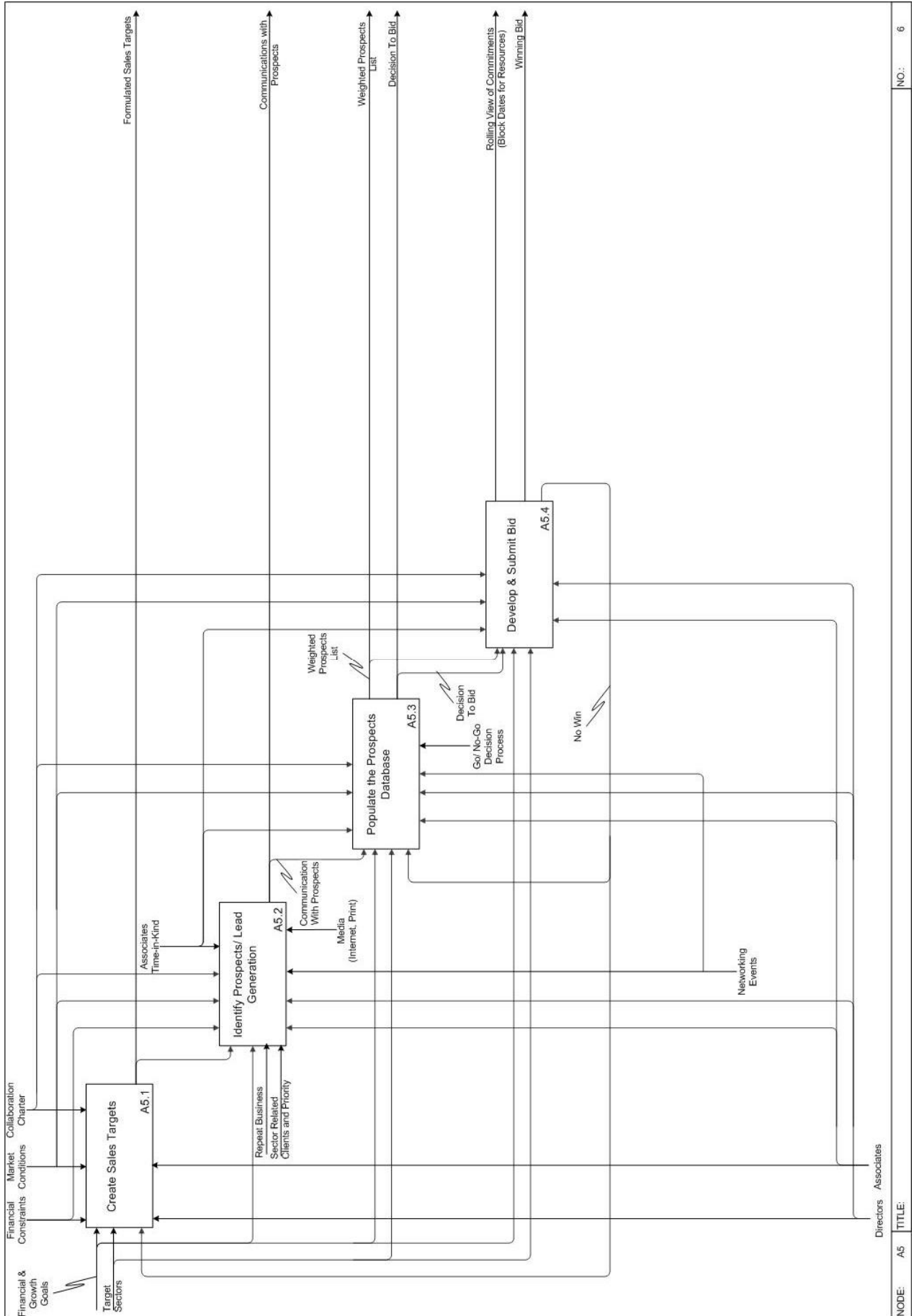

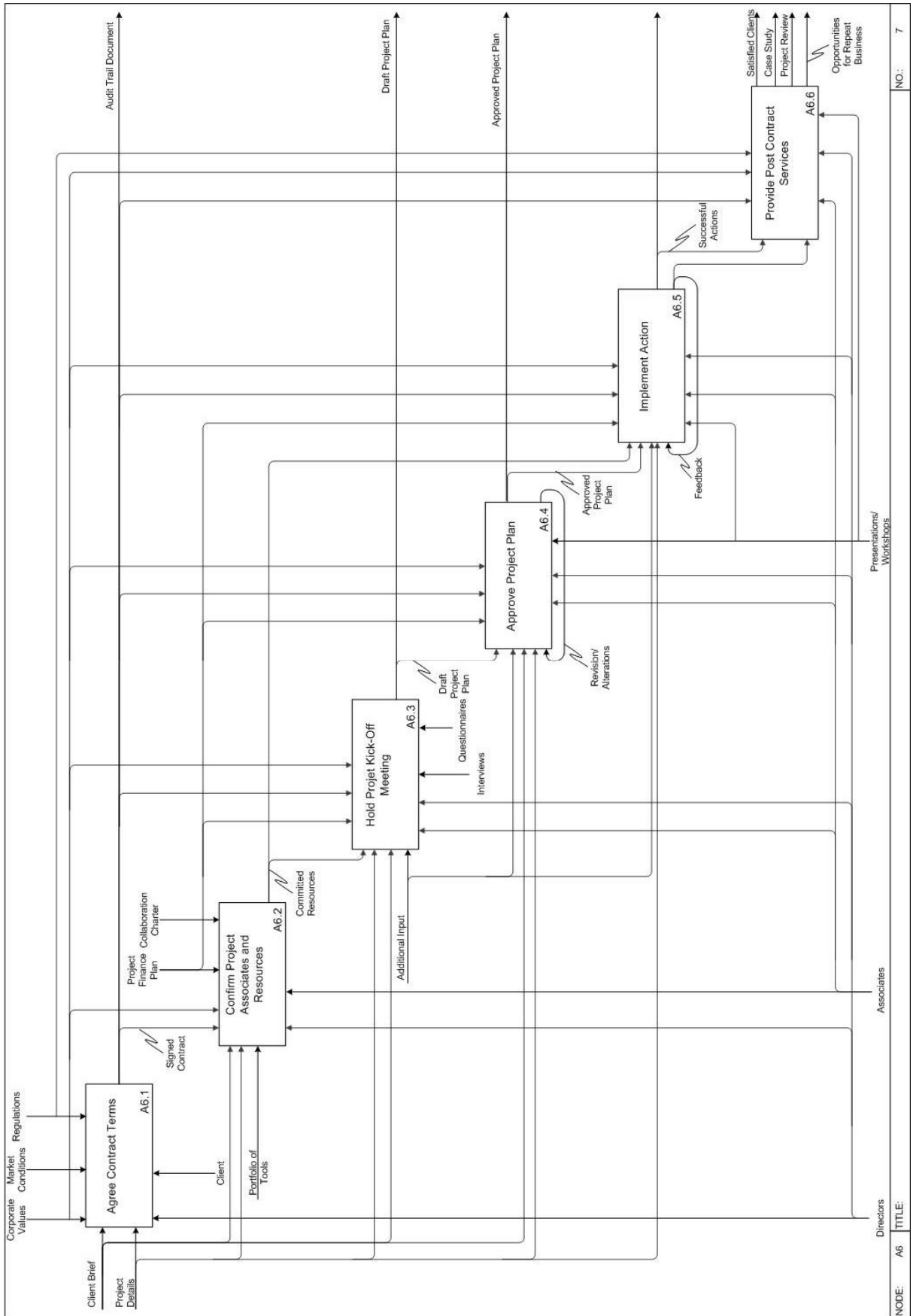

NO: 7

NODE: A6 TITLE:



## APPENDIX H – TOOLS SCENARIO FOR SERVQ PROJECT

This appendix provides the description of two projects considered for scenario building to study synergy between ServQ tools and techniques. The description is followed by a discussion on the scenarios generated for each project.

### **Project 1: Sales improvement in a building product and systems manufacturer**

#### *The Client Organisation:*

An international diversified manufacturer of industrial products (including building) in focused niche markets. Net sales of more than \$2 billion per annum with 12,000 employees in 25 countries.

#### *Key objective of the Project:*

Growth in volume whilst maintaining or growing margins.

#### *Business model:*

- Sales were for predominantly Building Services markets.
- Ideally products were specified by consultants thereby restricting the contractor's choice of supplier.
- Increasingly contractors operated on a "design" and "build" approach.
- Most of the products sold through distributors.
- Aim was to stimulate demand with consultants and contractors and supply through Distributors.

#### *Points to note:*

The organisation brands needed to retain independent recognition with Customers.

#### *Specific requirements:*

- Need to adopt a "standard" selling approach. Increasingly using sales logic to track leads and salesman's visits/call plans.
- Need to be "sold" to the sales guys and become the accepted method of working.
- Is the standard method being used/introduced at present the best – are there better ways?
- Need to create ownership of the process and train the guys in how to operate in such a process.
- Need to "shift" the selling approach from being reactive to being pro active. At the present time sales people have generally been "followers up" against known contract awards. For the future we want them to adopt an approach of tracking leads and generating their own strategy to best position the company and our distributors to win these contracts and to plan how to grow their territories.

#### *Present objectives of the Client:*

To identify a sales trainer with experience of:









- Building services environment, particularly consultant /contractor/ distributor relationships
- Structured standard selling/sales management processes with examples

- Selling these principles to, and training sceptical sales personnel Websites

### Scenarios generation for Project 1

This section will briefly describe the different scenarios that can be undertaken to deliver the required services for the current project. Two possible scenarios are discussed for the current project based on the project brief. The table below describes how the two suggested solutions are different in terms of the key internal factors involved in Project 1 (see Table 1). In scenario 1, the research considers a part use of a mixture of different tools and technologies available to ServQ for achieving client’s objectives while Value Management Framework (VMF) becomes the primary tool for scenario 2 and other tools support VMF to achieve the objectives. The use of legacy tools prominently in scenario 1 is different to the use of a mixture of different tools being used in scenario 2. Consequently, scenario 1 has a combination of representation techniques for delivering the service while scenario 2 is highly diagrammatic and workshop oriented. Lastly, scenario 2 will require specialist facilitators for conducting workshops, while the solution for scenario 1 is more generalised. Hence, it is clear from the table that the scenario solutions are different for the same project.

Table 1: Key internal factors for different routes to carry out scenario 1

Nos.	Identify Key Factors	Traffic Light Coding		Project 1	
		Uncertainty	Potential Impact	Scenario 1	Scenario 2
1	Origin industry for the tools (and its comparison to the end user industry)			Part use of different tools from different industries	VMF has roots in Construction Industry
2	Classification (Legacy tools vs. general techniques) establishes training requirements			A mixture of legacy tool components and general techniques	Legacy tools prominent within this scenario
3	Type of representation in the tool or technique (questionnaire based, numerical model, diagrammatic, workshops combination, etc.)			Combination of different tools and supporting reports / manuals	Diagrammatic followed by workshop with questionnaire support
4	Availability of internally trained people for conducting the use of tools			ServQ directors with intermediate help	Specialised workshop facilitators

Both the scenarios would require the breaking up of the service to be provided into convenient process steps (see Table 2). This would facilitate the use of different tools at particular stages of the project. The different stages within the scenarios can be recognised as the different stages of the projects with a project milestone after each of the stages. The table below shows the solution suggested for both the scenarios for project 1. Scenario 1 needs to use a wide variety of tools and hence requires ServQ Associates involved had a good knowledge of all of these tools and techniques. Scenario 2 takes an approach that involves diagnosis of the primary issue through Implications Wheel (a licensed ServQ tool on strategy formulation) followed by a comprehensive Value Management Framework (a licensed ServQ technique for Value Management) exercise. The performance review is again based on the preliminary results of Implications Wheel. It is quite important that the project stakeholders (senior management team of the client as well as client's sales team) buy into the idea of Value Management Framework if it has to succeed. Hence, both set of scenarios would generate unique challenges.

Table 2: Process Steps for Scenarios

	<b>Process Steps</b>	<b>Prominent ServQ tools that can be employed</b>
<b>Scenario 1</b>		
1	Project Setup	BEACON for initial observations
2	Initial Fieldwork	
3	Competency mapping	Partnership Continuum
4	Workshop design	Value Management Framework
5	Team workshop and Planning	Implications Wheel
6	Field Implementation	Partnership Continuum and Value Management Framework follow-up
7	Performance Review	Against Partnership Continuum and BEACON
<b>Scenario 2</b>		
1	Proposal	Implications Wheel with Partnership Continuum support
2	Needs Analysis	
3	Workshops	Value Management Framework with Partnership Continuum support
4	Implementation	
5	Performance Review	Against Implications Wheel

Scenario 1 primarily proposes the use of BEACON for initial observations pertaining to tools, people, process and technology with respect to the sales performance of the organisation. The competency mapping of the sales team with the help of Partnership Continuum online questionnaires help derive the possible areas of improvement. The workshop design need to use these value opportunities generated highlighting possible intervention points. The resulting team workshop can use Implications Wheel to generate the implications of the different interventions proposed. Eventually, the field implementation of the interventions and the performance review can be carried out with the help of Value Management Framework and BEACON respectively.

Scenario 2 proposes comprehensive pre-project use of Implications Wheel to uncover the needs of the current project and the related implications. The workshop stage can be

conducted with the help of Value Management Framework to summarise the possible value interventions to increase sales and follow it up with the implementation. Lastly the performance review can be conducted against the implications identified in the Implications Wheel.

Both the scenarios give an example of how synergy can be generated with the use of different tools available in the ServQ portfolio. In scenario 1, specific ServQ tools are divided into process stages and isolated to be used individually for specific projects.

## **Project 2: Alliance development for a large British water and wastewater company**

### *The Client Organisation:*

The organisation is one of the largest organisations involved with the provision of water and waste water services in UK. With a turnover of £1 billion and a net coverage of 5 million customers within an area covering 18% of England/Wales region, it is a big organisation.

### *Key objective of the Project:*

Provide facilitation services to assist organisation in establishing and operating an Alliances over a period of 3 years.

### *Business model:*

It predominantly catered to a particular region within UK.

The services offered were essential and hence they needed to operate under strict legal and regulatory standards.

Organisation owned by a consortium of investors.

Aim was to select a number of contractors and consultants for establishing an Alliance.

### *Points to note:*

The Alliance should enter the downstream supply chain of the organisation to establish collaborative procurement agreements (frameworks) complying with EU procurement legislation.

### *Specific requirements:*

- Provide further efficiency saving in the delivery of the capital programme for the Alliance.
- Obtain greater certainty and transparency of cost within the Alliance.
- Select the “best in class” service providers to help manage and deliver the capital programme.
- To demonstrate continuous improvement.
- 

### *Present objectives of the Client:*

To identify a facilitation consultant with experience of:

- Establishment of an Alliance and the initial operation
- Maintenance of an Alliance.
- Measuring performance and improvements within the Alliance.

## **Scenario generation for Project 2**



This section considers two different scenarios for project 2. The project brief describes the need to facilitate alliance development for a water services organisation. The division of project processes for the two scenarios of project 2 are based on different management outlooks.

The first scenario considers the project view of building up an alliance, while the second scenario considers the alliance management view (see table 3). Hence, scenario 1 considers the construction stages of an alliance and relies heavily on Partnership Continuum to develop trust, win/win orientation, future outlook and comfort with change within the alliance building process. The Partnership Continuum tools was supported by BEACON and Value Management Framework for the activities. Whilst scenario 2 considered the alliance management view. It broadly divides the project into two phases of alliance set-up and maintenance. Within these two phases two sub-phases are identified in the form of alliance setup and maintenance at strategic level and project team level. The result of such an arrangement is that three different types of tools can be used at various levels. Consequently, ServQ can decide to comprehensively use one of these tools based on the client requirements and the other two tools can support the foremost tool for that project.

Table 3: Process Steps for Scenarios

	<b>Process Steps</b>	<b>Prominent ServQ tools that can be employed</b>
<b>Scenario 1 - Project View</b>		
1	Pre-project phase	Stage 1 of Partnership Continuum with BEACON support
2	Pre-construction phase	Stage 2 of Partnership Continuum with BEACON support
3	Project Start-up phase	Stage 3 of Partnership Continuum with Value Management support
4	Construction phase	Stage 4 of Partnership Continuum with Value Management Support
5	Post completion phase	BEACON audit update
<b>Scenario 2 - Alliance Management View</b>		
1	Alliance Set-up	BEACON to assess overall readiness
1a.	Set-up at strategic / managerial level	Risk management and exploration with Implications Wheel
1b.	Set-up at project team level	Project team set-up with the help of VMF
2	Alliance maintenance	BEACON audit update
2a.	Maintenance at strategic / managerial level	Implications Wheel update
2b.	Performance review and lessons learnt at project team level	Value Management Framework Feedback Workshop

In Project 2, the scenarios generated consider different management views to execute the projects. Hence, it gives a choice of method to follow taking into consideration how the client would like to carry out the project or based on the specific requirement of the project as analysed by the needs analysis.



## APPENDIX I – EVALUATION QUESTIONNAIRE

### Evaluation Questionnaire



#### General Instructions

- If the space for comments is inadequate, separate attachments may be added.
- All evaluation to be retained with the researcher and are subject to review and limited to the researcher.
- The evaluation would be used for academic purposes with a concise report for the sponsor organisation.
- The report would be available to the evaluators on request.

#### For Evaluation purposes definition of ServQ stakeholders

- ServQ Directors and Employees – They are directly involved with ServQ on a daily basis. They are responsible for the operational, organisational as well as strategic management of ServQ limited.
- Associates – ServQ Associates are the consultants working with ServQ collaboratively and providing their services.
- Strategic Partners – Strategic Partners are experts in particular fields and they generate and provide new collaboration tools in the fields of their expertise for ServQ to use with clients

**People Related Evaluation Questionnaire**

No.		N.A.	Strongly Disagree	Somewhat Disagree	Neither Agree or Disagree	Somewhat Agree	Strongly Agree
A.1	I understand the importance of adoption of Collaboration Charter within ServQ collaborative arrangement.						
A.2	The Collaboration Charter ensures communication of the importance of common vision between the stakeholders.						
A.3	I feel the expected communication channels between the stakeholders are clear through the collaboration charter.						
A.4	The Collaboration Charter reflects the collaborative working environment that I would like to work in.						
A.5	The Collaboration Charter clearly sets out professional development assistance available to the stakeholders.						
A.6	The Collaboration Charter would help encourage stakeholder trust and commitment.						
A.7	The Collaboration Charter would be helpful in providing support to sustain long term collaboration.						
A.8	The periodic review process identified in the Collaboration Charter will help reflect the changing needs of collaboration.						
A.9	Shortening of service delivery time would be possible due to enhanced communication						

**Additional Comments** (refer question number followed by comments)

.....  
 .....  
 .....

### Process Related Evaluation Questionnaire

No.		N.A.	Strongly Disagree	Somewhat Disagree	Neither Agree or Disagree	Somewhat Agree	Strongly Agree
<b>B.1</b>	I believe that consensus building in terms of the organisational processes is helpful in collaborative working						
<b>B.2</b>	I think the process model provides required detail still ensuring the flexibility envisioned for collaborative working						
<b>B.3</b>	I believe stakeholder participation would be valued in the process model development						
<b>B.4</b>	I believe the process model enables the ownership of processes						
<b>B.5</b>	I believe the process model identifies the resource requirements for each process.						
<b>B.6</b>	I believe a new stakeholder can be initiated into the collaboration with the help of the process model						
<b>B.7</b>	I believe the process model helps to delineate stakeholders with different motivations						
<b>B.8</b>	Shortening of service delivery time would be possible due to clear communication						
<b>B.9</b>	Standardised approach to project implementations balanced with the flexibility and freedom to stakeholders						
<b>B.10</b>	Help identify the specific training requirements of tools						

#### Additional Comments (refer question number followed by comments)

.....

.....

.....

.....

.....

.....

**Tools Related Evaluation Questionnaire**

No.		N.A.	Strongly Disagree	Somewhat Disagree	Neither Agree or Disagree	Somewhat Agree	Strongly Agree
C.1	The scenario planning exercise provides an insight into the different types of tools available for collaboration						
C.2	The scenario planning exercise identifies the synergies that might be present between the tools						
C.3	The exercise can be used to conduct gap analysis of the tools available with respect to ServQ strategy						
C.4	The scenario planning exercise can be used to commit support for additional tools in collaboration						
C.5	The business cases built on with the scenario planning would be a source of explicit knowledge within the collaboration						
C.6	The scenario planning helps to engage stakeholders at major points of engagement by prior identification						
C.7	Individual understanding of stakeholders regarding the core competencies of the collaboration increase through scenario planning						
C.8	It would help identify and generate Intellectual property through new service offerings						
C.9	Identification of specific training requirements of tools						
C.10	Resource management in terms of core competency availability within the collaboration						

**Additional Comments** (refer question number followed by comments)

.....  
 .....  
 .....  
 .....  
 .....

Overall Comments

No.		N.A.	Strongly Disagree	Somewhat Disagree	Neither Agree or Disagree	Somewhat Agree	Strongly Agree
D.1	A purposeful overall strategy that helps smooth collaborative arrangement						
D.2	A helpful jargon free understanding for the clients in terms of service offerings of the collaboration, the core competencies and the people resources available						

Additional Comments (refer question number followed by comments)

.....  
 .....  
 .....  
 .....  
 .....

1. Were the existing barriers within ServQ’s collaborative environment identified and explained properly?

.....  
 .....  
 .....  
 .....  
 .....  
 .....  
 .....  
 .....

2. When the issues were divided into factors, were each of the factors explained in brief including what those factors cover? If not, what else could have been added?

.....  
 .....  
 .....  
 .....  
 .....  
 .....  
 .....  
 .....

3. Collaboration Charter – Its aims, objectives and end result were made clear –

.....  
 .....  
 .....  
 .....  
 .....

.....  
.....  
.....

4. ServQ Process Model – Its aims, objectives and end result were made clear –

.....  
.....  
.....  
.....  
.....  
.....  
.....  
.....  
.....

5. Advantages and Limitations of the current VECW framework –

Advantages –

- 1. ....  
.....  
.....
- 2. ....  
.....  
.....
- 3. ....  
.....  
.....

Barriers –

- 1. ....  
.....  
.....
- 2. ....  
.....  
.....
- 3. ....  
.....  
.....

6. Can the final guidelines table of VECW further improved? If yes, please give suggestion

.....  
.....  
.....  
.....  
.....  
.....  
.....  
.....





Gohil, U 2011. "Value Enhanced Collaborative Working (VECW)",  
Loughborough University (EngD Thesis)  
ISBN: 978 1 907382 48 2

Centre for Innovative and Collaborative Construction Engineering  
Department of Civil and Building Engineering  
Loughborough University Loughborough Leicestershire LE11 3TU

[www.cice.org.uk](http://www.cice.org.uk)

**CICE**