

This item was submitted to Loughborough's Institutional Repository (<https://dspace.lboro.ac.uk/>) by the author and is made available under the following Creative Commons Licence conditions.



For the full text of this licence, please go to:
<http://creativecommons.org/licenses/by-nc-nd/2.5/>

Tracking Mobile Targets through Wireless Sensor Networks

by

Tareq Alhmiedat

A Doctoral Thesis

Submitted in partial fulfilment
of the requirements for the award of

Doctor of Philosophy

of

Loughborough University

October 2009

Copyright 2009 Tareq Alhmiedat

ACKNOWLEDGMENTS

Firstly, I would like to thank my supervisor Prof. Shuang-Hua Yang for his advice and encouragement in the supervision of this study. He has always been generous with time and has had a great influence on the work. Also, my director of research Dr. Eran Edirisinghe for guiding my research. And I would like to thank Loughborough University for supporting with many facilities which helped me to accomplish my research.

A special thank goes to Dr. Hesham Abu-saimeh and Mr. Kushvinder Gill for their generous support in spirit, encouragement, patience and helpful advice through all these years.

I would like to express my sincere gratitude to Mr. Hazem Qattous for motivating me to do MSc and PhD studies and sharing his valuable experience. I would like also to thank the following people for their help and support during my PhD period: Mohannad Ajlane, Ahmad Alburdani, Layla Hasan, Fang Yao, Ashraf Najdawi, Hamza Alsaket, and Aref Zayd.

Many thanks to my brothers and sisters, a special thank to my elder brother Wael Alhmiedat for his encouragement and support, many thanks to Mohammad, Anas, Abeer, Ola, Shereen, Enas and Gadeer, for their support.

Finally, and the most important, I would like to express my thanks to my father, the great person whose encouragement and support were the main reason, for my success in my life. His help and spiritual supports were the main with no limits.

I would like also to thank my mother. The research was written because of her. Her support and encouragement motivated me to study and write during the work of this thesis, and my previous studies. Her love gave me the support to try, the patient to continue, and was the reason to success.

ABSTRACT

In recent years, advances in signal processing have led to small, low power, inexpensive Wireless Sensor Network (WSN). The signal processing in WSN is different from the traditional wireless networks in two critical aspects: firstly, the signal processing in WSN is performed in a fully distributed manner, unlike in traditional wireless networks; secondly, due to the limited computation capabilities of sensor networks, it is essential to develop an energy and bandwidth efficient signal processing algorithms.

Target localisation and tracking problems in WSNs have received considerable attention recently, driven by the necessity to achieve higher localisation accuracy, lower cost, and the smallest form factor. Received Signal Strength (RSS) based localisation techniques are at the forefront of tracking research applications.

Since tracking algorithms have been attracting research and development attention recently, prolific literature and a wide range of proposed approaches regarding the topic have emerged. This thesis is devoted to discussing the existing WSN-based localisation and tracking approaches.

This thesis includes five studies. The first study leads to the design and implementation of a triangulation-based localisation approach using RSS technique for indoor tracking applications. The presented work achieves low localisation error in complex environments by predicting the environmental characteristics among

beacon nodes. The second study concentrates on investigating a fingerprinting localisation method for indoor tracking applications. The proposed approach offers reasonable localisation accuracy while requiring a short period of offline computation time. The third study focuses on designing and implementing a decentralised tracking approach for tracking multiple mobile targets with low resource requirements.

Despite the interest in target tracking and localisation issues, there are few systems deployed using ZigBee network standard, and no tracking system has used the full features of the ZigBee network standard. Tracking through the ZigBee is a challenging task when the density of router and end-device nodes is low, due to the limited communication capabilities of end-device nodes. The fourth study focuses on developing and designing a practical ZigBee-based tracking approach.

To save energy, different strategies were adopted. The fifth study outlines designing and implementing an energy-efficient approach for tracking applications. This study consists of two main approaches: a data aggregation approach, proposed and implemented in order to reduce the total number of messages transmitted over the network; and a prediction approach, deployed to increase the lifetime of the WSN.

For evaluation purposes, two environmental models were used in this thesis: firstly, real experiments, in which the proposed approaches were implemented on real sensor nodes, to test the validity for the proposed approaches; secondly, simulation experiments, in which NS-2 was used to evaluate the power-consumption issues of the two approaches proposed in this thesis.

Keywords: Wireless Sensor Network, Tracking, Localisation, Fingerprinting, ZigBee, Data Aggregation, Prediction, Power Consumption.

Tareq Alhmiedat, 2009

PUBLICATIONS

Journal Publication

Alhmiedat, T. A. and Yang, S., “A ZigBee-based Mobile Tracking System Through Wireless Sensor Networks”, *Int. Advanced Mechatronic Systems*, 1(1), pp. 63-70, 2008.

Conferences' Publications

Alhmiedat, T. A. and Yang, S., “Improved WSN Based Localisation Approach Using Fingerprinting”, *Proceedings of the 5th International Conference on Intelligent Sensors, Sensor Networks and Information Processing*, Melbourne, Australia, Dec. 2009.

Alhmiedat, T. A. and Yang, S., “Tracking Multiple Mobile Targets Based on ZigBee Standard”, *Proceedings of the 35th Annual Conference of the IEEE Industrial Electronics Society*, Porto, Portugal, Nov. 2009.

Alhmiedat, T. A. and Yang, S., “A Decentralised Low-Power ZigBee-based Localisation Approach”, *Proceedings of the 14th International Conference on Automation & Computing*, Brunel University, Uxbridge, UK, pp. 41, Sept. 2008.

Alhmiedat, T. A. and Yang, S., “A Survey: Localization and Tracking Mobile Targets Through Wireless Sensor Network”, *Proceedings of the PGNet Conference*, Liverpool, UK, pp. 48, 2007.

ABBREVIATIONS

ACK	:	Acknowledgement Packet
AODV	:	Add hoc On-demand Distance Vector
AP	:	Access Point
APIT	:	A Point In Triangle
APS	:	Ad hoc Positioning System
DARPA	:	Defence Advanced Research Projects Agency
DB	:	Database
ESA	:	European Space Agency
EU	:	European Union
FFD	:	Full Function Devices
GNSS	:	Global Navigation Satellite System
GPS	:	Global Positioning System
GSM	:	Global System for Mobile communications
GUI	:	Graphical User Interface
IEEE	:	Institute of Electrical and Electronics Engineering

LAN	:	Local Area Network
LQI	:	Lind Quality Indicator
MAC	:	Medium Access Control
MAN	:	Metropolitan Area Network
MLP	:	Multi-Layer Perceptron
NN	:	Neural Network
NS-2	:	Network Simulator-2
NWK	:	Network layer
OSS	:	One-Step Secant
PAN	:	Personal Area Network
PDA	:	Personal Digital Assistants
PHY	:	Physical Layer
RBF	:	Radial Basis Function
RF	:	Radio Frequency
RFD	:	Reduced Function Devices
RFID	:	Radio Frequency Identification
RNN	:	Recurrent Neural Network
RSS	:	Received Signal Strength
RSSI	:	Received Signal Strength Indicator
SS	:	Signal Strength
TDOA	:	Time Difference Of Arrival
TOA	:	Time Of Arrival
TOF	:	Time Of Flight
WAN	:	Wireless Area Network
WN	:	Wireless Network

WPAN	:	Wireless Personal Area Network
WSN	:	Wireless Sensor Network
ZC	:	ZigBee Coordinator
ZED	:	ZigBee End-Device
ZR	:	ZigBee Router

LIST OF SYMBOLS

A	:	Sub-area
agt	:	Aggregation time
b	:	Beacon node (the node with known coordinate position)
be	:	Beacon End-device node
br	:	Beacon Router node
cm	:	Centimetre
dr	:	Detection Range
d	:	Direction
E	:	Localisation Error
ef	:	Environment Factor
ft	:	Final Time for the experiment
Gt	:	Gain Transmitter
Gr	:	Gain Receiver
h	:	Number of hops
l	:	Leader node

m	:	Meter
mg	:	Mobile Group leader
MT	:	Mobile Target
na	:	Total number of nodes in active mode
nb	:	Total number of observer nodes
nn	:	Nearest Neighbour
ns	:	Total number of nodes in sleep mode
ob	:	Observer node
P	:	Power consumption
p	:	Position coordinates
Pact	:	Power consumption in active mode
Pdrm	:	Power consumption in sleep mode
Ptx	:	Transmission power
Prx	:	Reception power
q	:	Quality of observation
s	:	Sink node
si	:	Sampling Interval
t	:	Time
tr	:	Transmission Range
v	:	Velocity
x	:	x-coordinate
y	:	y-coordinate

TABLE OF CONTENTS

ACKNOWLEDGMENTS -----	I
ABSTRACT -----	III
PUBLICATIONS -----	V
ABBREVIATIONS -----	VI
LIST OF SYMBOLS -----	IX
TABLE OF CONTENTS -----	XI
TABLE OF FIGURES -----	XIV
TABLE OF TABLES -----	XVI
CHAPTER 1 INTRODUCTION -----	1
1.1 COMPUTER NETWORKS-----	1
1.2. WIRELESS SENSOR NETWORK-----	3
1.2.1 WSN Applications-----	5
1.2.2 Wireless Sensor Architecture-----	5
1.2.3 Wireless Sensor Stack-----	7
1.2.4 Wireless Sensor Network Standards-----	8
1.2.5 Tracking Applications-----	11
1.3 PROBLEM OVERVIEW-----	12
1.3.1 Localisation Technique-----	12
1.3.2 Power-consumption-----	13
1.4 RESEARCH OBJECTIVES-----	13
1.5 MAIN CONTRIBUTIONS OF THE THESIS-----	14
1.6 THESIS LAYOUT-----	15
CHAPTER 2 LOCALISATION AND TRACKING SYSTEMS -----	17
2.1 BACKGROUND-----	17
2.2 ISSUES IN LOCALISATION ALGORITHM DESIGN-----	17
2.3 LOCALISATION METHODS-----	19
2.3.1 Triangulation-----	19
2.3.2 Fingerprinting-----	19
2.3.3 Time of Arrival-----	20
2.3.4 Time Difference of Arrival-----	21
2.4 LOCALISATION AND TRACKING SYSTEMS-----	22

2.4.1. <i>Global Navigation Satellite Systems</i> -----	23
2.4.2 <i>WSN Localisation Systems</i> -----	25
2.4.3 <i>Mobile Network based Systems</i> -----	39
2.5 SUMMARY -----	40
CHAPTER 3 A RSS BASED TRIANGULATION APPROACH -----	42
3.1 BACKGROUND AND MOTIVATION -----	42
3.2 RSS BASED LOCALISATION APPROACH -----	43
3.2.1 <i>Received Signal Strength</i> -----	43
3.2.2 <i>Link Quality Indicator</i> -----	44
3.2.3 <i>RSS based Localisation System</i> -----	44
3.3 EXPERIMENTS -----	49
3.3.1 <i>Hardware Platform</i> -----	50
3.3.2 <i>Experimental Test-bed</i> -----	50
3.3.3 <i>Analysing RSS Measurements</i> -----	51
3.3.4 <i>Adjusting RSS Measurements</i> -----	52
3.4 SYSTEM EVALUATION -----	53
3.4.1 <i>Accuracy</i> -----	53
3.4.2 <i>Communication Cost</i> -----	54
3.5 DISCUSSION-----	55
3.6 SUMMARY -----	56
CHAPTER 4 A FINGERPRINTING BASED LOCALISATION APPROACH -----	58
4.1 BACKGROUND AND MOTIVATION -----	58
4.2 FINGERPRINTING BASED APPROACH -----	59
4.2.1 <i>Creation of the Fingerprint Table Phase</i> -----	60
4.2.2 <i>Feature Identification Phase</i> -----	61
4.2.3 <i>Estimation Phase</i> -----	62
4.3 EXPERIMENTS -----	63
4.3.1 <i>Graphical User Interface</i> -----	63
4.3.2 <i>Mobile and Reference Node Model</i> -----	65
4.3.3 <i>Experimental Test-beds</i> -----	65
4.4 TESTING RESULTS AND PERFORMANCE EVALUATION -----	66
4.4.1 <i>Localisation Accuracy</i> -----	67
4.4.2 <i>The Efficiency of the Segmentation Process</i> -----	70
4.5 DISCUSSION-----	72
4.6 SUMMARY -----	74
CHAPTER 5 A DECENTRALISED TRACKING APPROACH -----	75
5.1 BACKGROUND AND MOTIVATION -----	75
5.2 DECENTRALISED TRACKING APPROACH -----	76
5.2.1 <i>Initialisation Phase</i> -----	77
5.2.2 <i>Localisation Phase</i> -----	77
5.2.3 <i>Grouping Phase</i> -----	77
5.3 SIMULATION SETUP-----	79
5.4 SYSTEM EVALUATION -----	81
5.4.1 <i>Communication Costs</i> -----	81
5.4.2 <i>Power-consumption</i> -----	84
5.5 DISCUSSION-----	85
5.6 SUMMARY -----	86
CHAPTER 6 TRACKING THROUGH ZIGBEE NETWORK -----	87
6.1 BACKGROUND AND MOTIVATION -----	87
6.2 TRACKING MULTIPLE MOBILE TARGETS-----	88
6.2.1 <i>Detection</i> -----	89
6.2.2 <i>Search</i> -----	89
6.2.3 <i>Selection</i> -----	91
6.2.4 <i>Localisation and Tracking</i> -----	93
6.2.5 <i>Alerting</i> -----	95
6.3 EXPERIMENT SETUP -----	95

6.3.1 <i>Sensor Node Model</i> -----	95
6.3.2 <i>Experiment Test-bed</i> -----	96
6.3.3 <i>Target Node Model</i> -----	97
6.4 SYSTEM EVALUATION-----	98
6.4.1 <i>Tracking Accuracy</i> -----	98
6.4.2 <i>Collision Avoidance</i> -----	101
6.4.3 <i>Power-consumption</i> -----	101
6.5 DISCUSSION-----	103
6.6 SUMMARY -----	104
CHAPTER 7 AN ENERGY EFFICIENT TRACKING APPROACH-----	106
7.1 BACKGROUND AND MOTIVATION-----	106
7.2 AN ENERGY EFFICIENT APPROACH -----	107
7.2.1 <i>System Requirements and Metrics</i> -----	107
7.2.2 <i>Energy Saving Strategies</i> -----	108
7.2.3 <i>System Design</i> -----	110
7.3 IMPLEMENTATION-----	114
7.3.1 <i>Network Topology</i> -----	114
7.3.2 <i>Beacon Node Model</i> -----	116
7.3.3 <i>Mobile Target Model</i> -----	116
7.4 SYSTEM EVALUATION-----	116
7.4.1 <i>Total Number of Messages</i> -----	116
7.4.2 <i>Power-consumption</i> -----	118
7.4.3 <i>Tracking Accuracy</i> -----	120
7.5 DISCUSSION-----	122
7.6 SUMMARY -----	123
CHAPTER 8 CONCLUSIONS AND FUTURE WORK -----	124
8.1 CONCLUSIONS -----	124
8.2 OUTCOMES-----	125
8.2.1 <i>Outcome 1: Research current literature</i> -----	125
8.2.2 <i>Outcome 2: Improve localisation accuracy</i> -----	125
8.2.3 <i>Outcome 3: Achieve low power-consumption for tracking large numbers of mobile targets</i> -----	126
8.2.4 <i>Outcome 4: Propose a ZigBee based multiple mobile tracking approach</i> -----	126
8.2.5 <i>Outcome 5: Propose an energy-efficient approach for tracking applications</i> -----	127
8.2.6 <i>Outcome 6: Implement the proposed approaches</i> -----	127
8.2.7 <i>Outcome 7: Publish the proposed work</i> -----	127
8.3 POTENTIAL EXTENSIONS OF THE RESEARCH-----	128
REFERENCES-----	129

TABLE OF FIGURES

FIGURE 1-1: MULTI HOP WIRELESS SENSOR NETWORK -----	3
FIGURE 1-2: JENNIC SENSOR NODE-----	4
FIGURE 1-3: SENSOR NODE COMPONENTS-----	6
FIGURE 1-4: WIRELESS SENSOR NODE STACK-----	7
FIGURE 1-5: ZIGBEE NETWORK TOPOLOGIES -----	10
FIGURE 1-6: A TRACKING APPLICATION-----	11
FIGURE 2-1: TRIANGULATION METHOD -----	19
FIGURE 2-2: FINGERPRINTING METHOD -----	20
FIGURE 2-3: TOA METHOD -----	21
FIGURE 2-4: TDOA METHOD -----	22
FIGURE 2-5: CLASSIFICATION OF TRACKING TECHNOLOGIES -----	23
FIGURE 2-6: CENTRALISED AND DECENTRALISED TRACKING SYSTEMS -----	26
FIGURE 2-7: ACOUSTIC BASED LOCALISATION SENSOR WITH MICROPHONE -----	33
FIGURE 2-8: TRACKING SYSTEM BASED ON ACOUSTIC BEHAVIOURS-----	34
FIGURE 2-9: APIT TECHNIQUE-----	37
FIGURE 3-1: SIGNAL STRENGTH PATTERN IN OPEN ENVIRONMENT-----	45
FIGURE 3-2: SIGNAL STRENGTH PATTERN WITH OBSTACLES-----	46
FIGURE 3-3: LOCALISATION PHASES-----	46
FIGURE 3-4: LOCALISATION METHOD BASED ON ENVIRONMENTAL FACTORS -----	48
FIGURE 3-5: LOCALISATION ALGORITHM -----	49
FIGURE 3-6: FK OFFICE TEST ENVIRONMENT -----	51
FIGURE 3-7: ANALYSING RSS VALUES THROUGH DIFFERENT POINTS -----	52
FIGURE 3-8: AVERAGE OF RSS VALUES-----	52
FIGURE 3-9: LOCALISATION ERROR FOR THE PROPOSED SYSTEM THROUGH SEVERAL TEST POINTS ----	54
FIGURE 3-10: PROPOSED APPROACH VERSUS AN EXISTING RSS TRIANGULATION -----	56
FIGURE 4-1: FINGERPRINTING BASED APPROACH -----	59
FIGURE 4-2: LOCALISATION PROCESS -----	63
FIGURE 4-3: GUI FOR THE PROPOSED SYSTEM-----	64
FIGURE 4-4: AUTONOMOUS SEGMENTATION PROCESS-----	65
FIGURE 4-5: TEST-BED 1, FK OFFICE TEST ENVIRONMENT -----	66
FIGURE 4-6: TEST-BED 2, SPORTS HALL TEST ENVIRONMENT-----	66
FIGURE 4-7: ERROR DISTANCE BASED ON THE NUMBER OF REFERENCE POINTS -----	68
FIGURE 4-8: LOCALISATION ERROR USING RBF METHOD IN TEST-BED 1 -----	68
FIGURE 4-9: LOCALISATION ERROR USING RBF METHOD IN TEST-BED 2-----	69
FIGURE 4-10: LOCALISATION ERROR USING 3NNF METHOD IN TEST-BED 1 -----	69
FIGURE 4-11: LOCALISATION ERROR USING 3NNF METHOD IN TEST-BED 2 -----	69
FIGURE 4-12: AUTONOMOUS SEGMENTATION PROCESS THROUGH TEST-BED 2-----	70

FIGURE 4-13: MANUAL SEGMENTATION PROCESS THROUGH TEST-BED 1 -----	71
FIGURE 4-14: LOCALISATION ERROR FOR TWO SYSTEMS -----	73
FIGURE 5-1: TRACKING MULTIPLE MOBILE TARGETS PROBLEM -----	76
FIGURE 5-2: MAIN PHASES OF DECENTRALISED TRACKING SYSTEM -----	77
FIGURE 5-3: FLOW CHART TO IMPLEMENT THE IMPROVED DECENTRALISED APPROACH-----	78
FIGURE 5-4: AN IMPROVED DECENTRALISED ALGORITHM -----	79
FIGURE 5-5: EXPERIMENTAL TEST-BED -----	81
FIGURE 5-6: TOTAL NUMBER OF MESSAGES FOR THE THREE SYSTEMS -----	83
FIGURE 5-7: EVALUATING THE POWER CONSUMPTION FOR THE THREE APPROACHES-----	85
FIGURE 6-1: MESH ZIGBEE NETWORK-----	88
FIGURE 6-2: TRACKING PROCESS -----	89
FIGURE 6-3: COMMUNICATION PROBLEM USING ZIGBEE -----	90
FIGURE 6-4: DISCONNECTION PROCESS -----	90
FIGURE 6-5: CONNECTION PROCESS -----	90
FIGURE 6-6: TRACKING MULTIPLE MOBILE TARGETS PROBLEM THROUGH ZIGBEE -----	91
FIGURE 6-7: LOCALISATION THROUGH AREA OF TRIANGLES -----	93
FIGURE 6-8: TIME MANAGEMENT METHOD FOR MOBILE TARGET NODE -----	94
FIGURE 6-9: ALERTING PROCESS -----	95
FIGURE 6-10: PSEUDO CODE RUNS ON EACH BEACON ROUTER NODE -----	96
FIGURE 6-11: PSEUDO CODE RUNS ON EACH END-DEVICE NODE -----	96
FIGURE 6-12: FK OFFICE TEST ENVIRONMENT-----	97
FIGURE 6-13: FK OFFICE TEST LAYOUT -----	97
FIGURE 6-14: PSEUDO CODE RUNS ON EACH MOBILE TARGET NODE -----	98
FIGURE 6-15: TRACKING PROCESS THROUGH ZIGBEE NETWORK -----	99
FIGURE 6-16: LOCALISATION ACCURACY FOR CLASS A -----	100
FIGURE 6-17: LOCALISATION ACCURACY FOR CLASS B -----	100
FIGURE 6-18: LOCALISATION ACCURACY FOR CLASS C -----	101
FIGURE 6-19: EVALUATING THE COLLISION AVOIDANCE EFFECT -----	101
FIGURE 6-20: TRACKING PROCESS THROUGH EXPERIMENT A -----	102
FIGURE 6-21: TRACKING PROCESS THROUGH EXPERIMENT B-----	102
FIGURE 6-22: EVALUATING THE POWER-CONSUMPTION FOR EXPERIMENTS (A & B)-----	103
FIGURE 7-1: MAIN STAGES-----	110
FIGURE 7-2: SENSOR NETWORK TOPOLOGY-----	115
FIGURE 7-3: TOTAL NUMBER OF MESSAGES FOR THE THREE STRATEGIES -----	118
FIGURE 7-4: POWER-CONSUMPTION FOR THE FOUR STRATEGIES -----	120
FIGURE 7-5: REAL TRAJECTORY -----	120
FIGURE 7-6: APPROXIMATED TRAJECTORY FOR STRATEGY 1 -----	121
FIGURE 7-7: APPROXIMATED TRAJECTORY FOR STRATEGY 2 -----	121
FIGURE 7-8: APPROXIMATED TRAJECTORY FOR STRATEGY 3 -----	122

TABLE OF TABLES

TABLE 3-1: ENVIRONMENT FACTORS THROUGH DIFFERENT ENVIRONMENTAL OBSTACLES-----	53
TABLE 4-1: DEFINITIONS OF PARAMETERS-----	60
TABLE 4-2: STRUCTURE OF DATABASE -----	61
TABLE 4-3: ASSIGNED CATEGORIES FOR TEST-BED 1 -----	71
TABLE 4-4: ASSIGNED CATEGORIES FOR TEST-BED 2 -----	72
TABLE 4-5: COMPARISON BETWEEN FINGERPRINTING APPROACHES-----	74
TABLE 5-1: SIMULATION PARAMETERS -----	80
TABLE 6-1: PARAMETERS DEFINITION-----	89
TABLE 6-2: LOCALISATION ACCURACY FOR EACH CLASS -----	100
TABLE 6-3: POWER-CONSUMPTION FOR EACH PHASE-----	102
TABLE 7-1: PARAMETERS DEFINITIONS -----	108
TABLE 7-2: SIMULATION PARAMETER VALUES-----	115
TABLE 7-3: NUMBER OF MESSAGES TRANSMITTED -----	117

CHAPTER 1

INTRODUCTION

1.1 Computer Networks

There has been massive growth in the area of computer networks over the last few years. Computer networks are widely used in business by both administrative and consumer users, as they allow the extraction and updating of information about the entire company. The main goal of computer networks is to make all programs, equipment, and especially data available to anyone on the network, regardless of the physical location of the resource and the users.

Computer networks can be divided into several types, such as local, metropolitan, wide area, and wireless networks. Local Area Networks (LANs) can be used within a single building, or campus, over a distance of a few kilometres, and are usually used to connect personal computers and workstations in company offices and factories to share resources and to exchange information. Metropolitan Area Networks (MANs) are used to cover a city. The most famous example of a MAN is the cable television network available in many cities. Wide Area Networks (WANs) are used to span a large geographical area, and are often used within a country or continent. Finally, Wireless Networks (WNs) are a wireless alternative to computer networks which use radio waves instead of wires to transmit and receive data between computers (Tanenbaum, 2003).

WN's have become prolific in large companies and security enhancements due to the following factors:

1. Mobility: WN's can provide users access to real-time information anywhere in their organisation. This property supports productivity, and it's not possible with wired networks.
2. Installation speed and simplicity: installing a WN is relatively easy and fast, and there is no need to pull cables through walls and ceilings.
3. Installation flexibility: WN's allow the network to go where the wires cannot.
4. Scalability: WN's systems can be configured in many ways to meet the needs of specific applications and installations.

WN's can be classified based on their coverage range into three main categories: Wireless Wide Area Networks (WWAN's), Wireless Local Area Networks (WLAN's), and Wireless Personal Area Network (WPAN's) (Hannikainen et al. 2003).

WWAN's include wide coverage area technologies such as 2G cellular, Cellular Digital Packet Data (CDPD), Global Systems for Mobile Communications (GSM), and Mobitex. WLAN's involves Wireless Local Area Networks, including 802.11, HiperLAN, and many others (Mallick, 2003).

WPAN's is a network used for interconnecting devices (a very large number of wireless devices can be connected) distributed around an individual workspace, in which all connections are wireless. This includes handheld computers, mobile phones, printers, microphones, speakers, bar code readers and sensors. The market of WPAN's is expanding rapidly. This kind of WN offers many advantages, such as:

- Short-range communication,
- low power-consumption,
- small personal networks,
- and communication of devices within a personal space.

1.2. Wireless Sensor Network

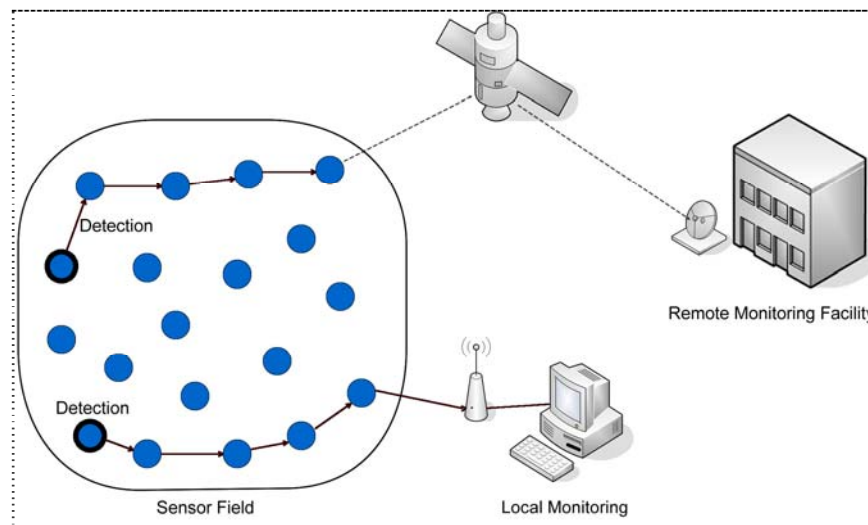

Figure 1-1: Multi hop wireless sensor network

Recent developments in wireless technology and the invention of small, inexpensive, low power microprocessors have led to the emergence of networked, embedded systems named wireless sensors. A Wireless Sensor Network (WSN) is a distributed collection of nodes that are resource constrained (short range, small memory size, and short battery life) and competent of operating with minimal user attendance.

The main goal of WSN is to permit multiple applications to run on top of the same sensor network. WSN's include hundreds or thousands of sensor nodes communicating over a wireless channel, achieving distributed sensing and collaborative data processing tasks for a variety of military and civilian applications. Sensor information can be gathered and analysed using local or remote monitoring, as depicted in Figure 1-1 (Galstyan, 2004).

As shown in Figure 1-2, sensor nodes are tiny electronic devices equipped with a battery for energy source, a sensor for determining physical characteristics, a processor for performing computations, a wireless transceiver for two way communications with other sensors, and a memory device for storing information and for local computation. A sensor node has the following characteristics: (1) small physical size; (2) low power-consumption; (3) limited processing power; (4) short-range communications; and (5) a small amount of storage.

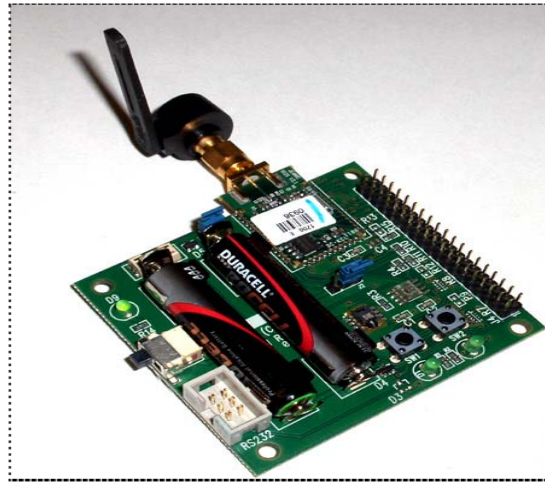

Figure 1-2: Jennic sensor node

Sensor nodes have been widely used. The initial research in this area was with an eye to military applications, with Defence Advanced Research Projects Agency (DARPA) continuing to fund a number of prominent research projects such as Smart Dust and NEST. Recently, civilian application of WSN's have been considered, such as environmental and species monitoring (water, air, soil, chemistry), agriculture, production and delivery, healthcare, and others. The main reasons behind the rapid adoption and spread of WSN's are the following:

- The wireless sensors are relatively cheap and small in size, which facilitates the high distribution of such networks.
- The networks of sensors may scale to many thousands of nodes, and thus cover a wide geographical area. This ensures that the sensing units are set close to the target event, and thus the sensed data will render qualitatively better geometric fidelity.
- The networks may sustain the failure of sensor nodes. WSN has the ability to reorganise itself.
- The advances in WSN techniques will ensure quick deployment of such systems. Sensor nodes are easily placed in the area of interest.
- The information about a specific event is simultaneously generated by multiple sensors due to the intensive deployment of sensor nodes.

These characteristics make sensor networks different from other WN's, and more efficient for several applications.

1.2.1 WSN Applications

WSN's have been deployed in several applications as identified by Karl and Willig, (2005); following is a summary of these WSN's applications:

- Military applications - WSN's form a critical part in military applications, such as control communication, computing, intelligence, surveillance, and target tracking systems. The low cost, rapid deployment, fault tolerance, and self-organisation characteristics of sensor nodes make them a very promising solution for military applications.
- Environmental applications - WSN's have been deployed widely in environmental applications such as habitat monitoring, animal tracking, forest-fire detection, precision farming, and disaster relief applications.
- Health applications - patients can be equipped with sensor nodes to monitor their vital signs and track their locations. Glucose-level monitoring is a possible application suitable for WSN's.
- Home applications - smart sensor nodes and actuators can be integrated in home systems, such as vacuum cleaners, micro-wave ovens, and refrigerators. End users can manage home devices locally and remotely by connecting these devices with each other and with an external network via the internet or satellite.
- Other commercial applications - these include monitoring material fatigue and produce quality, robot control and guidance in automatic manufacturing environments, monitoring disaster areas, detecting and monitoring car thefts, and vehicle tracking and detection.

1.2.2 Wireless Sensor Architecture

As depicted in Figure 1-3, each sensor node is made up of the following four basic units (Karl and Willig, 2005):

1. Sensing unit: this usually includes two subunits. Firstly, the sensor unit, which produces the analogue signals after sensing any

phenomena. Secondly, the Analogue-to-Digital Converter (ADC) unit, which converts the analogue signals to digital.

2. Processing unit: this consists of two subunits. Firstly, the processor unit, which processes and controls the functionality of other components in the sensor node. Secondly, the storage unit, which stores the information.
3. Transceiver unit: this is responsible for transmitting and receiving operations.
4. Power unit: this supplies the sensor node with energy. It could also be connected to another power supply unit or power generator, such as solar cells.

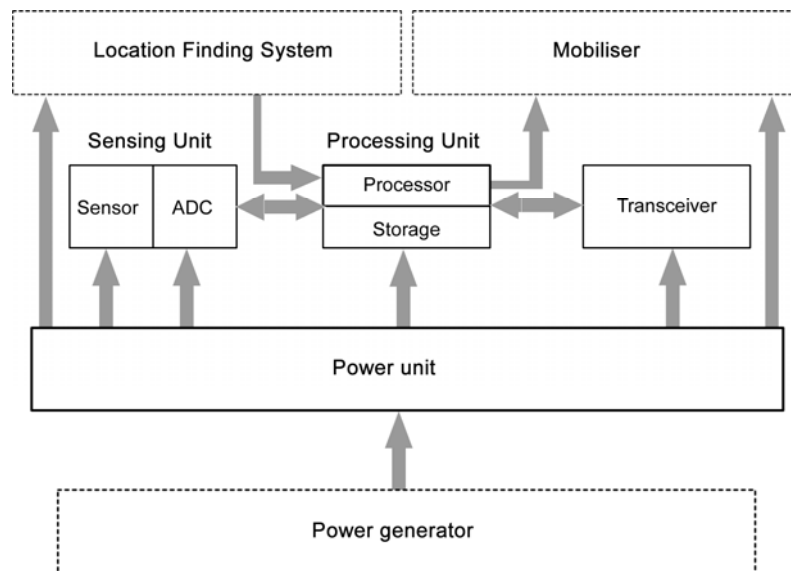

Figure 1-3: Sensor node components

A sensor node may have application-dependent additional components, such as a location finding system, and a mobiliser. Most of the sensor network routing techniques and sensing operations require the knowledge of position with high accuracy. Therefore, it is customary for a sensor node to have a location finding system. A mobiliser may be required to move sensor nodes, when required to carry out the assigned tasks (Akyildiz et al. 2002).

1.2.3 Wireless Sensor Stack

The wireless sensor stack, depicted in Figure 1-4, consists of five layers, namely the physical layer, data link layer, network layer, transport layer, and application layer. Each layer performs specific tasks.

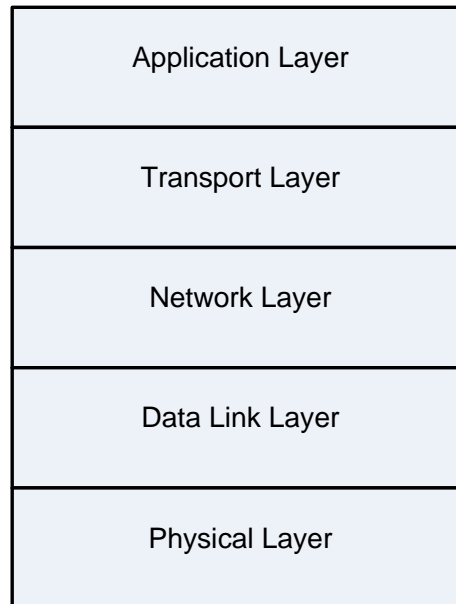

Figure 1-4: Wireless sensor node stack

The first layer from the bottom is the physical layer. It has the following tasks: frequency selection, carrier frequency generation, bit encoding, determining the voltage to be used for transmitting the bit stream over the physical medium, signal detection, modulation, and data encryption.

The second layer is the data link layer, also known as Medium Access Control (MAC). It is responsible for the multiplexing of data streams, data frame detection, medium access and error control. It also guarantees reliable point-to-point and point-to-multipoint connections in a communication network. MAC protocol must achieve two goals: firstly, creating the network infrastructure - because there are usually thousands of nodes scattered over the area of interest, the MAC must establish communication links for data transfer; and secondly, sharing communication resources between sensor nodes in a fair and efficient way.

The third layer is the network layer. The network layer of sensor networks is usually designed according to the following principles (Akyildiz et al. 2002):

- Energy efficiency is a persistently important consideration.

- Sensor networks are mainly data-centric.
- Data aggregation can be used when it does not hinder the collaborative effort of the sensor nodes.
- An ideal sensor network should be attribute based, addressing the location awareness.

The transport layer is the fourth one. This layer is responsible for handling delay and packet loss statistics, segmentation and reassembly of packets, setting up and maintaining end-to-end connections, reliable end-to-end delivery of data packets, and congestion control and flow control (Akyildiz et al. 2002).

The fifth layer is the application layer. This includes enabling the user to access the network, as well as three possible application layer protocols: Sensor Management Protocol (SMP), Task Management and Data Advertisement Protocol (TADAP), and Sensor Query and Data Dissemination Protocol (SQDDP).

1.2.4 Wireless Sensor Network Standards

Many WN's standards have been developed recently, such as 802.11a, b, g, Bluetooth, 802.15.4, and ZigBee network standards. In this section, the most popular WSN standards are considered.

1.2.4.1 IEEE 802.15.4 Network standard

IEEE 802.15.4 network standard is a low data rate WPAN standard. It is designed to offer fundamentally lower network layers of a type of WPAN, which focuses on low cost and low power-consumption devices. These devices depend on long battery life, normally a couple of years. IEEE 802.15.4 is the basis for the ZigBee, WirelessHART and MiWi network standards (Labioud et al. 2007).

IEEE 802.15.4 standard supports two types of devices: a Full-Function Device (FFD) and a Reduced-Function Device (RFD). Usually, FFD can function as a master or a Personal Area Network (PAN) coordinator, whereas the RFD is normally a slave or a regular node where there is no master-slave communication (Baronti et al. 2006).

1.2.4.2 WirelessHART

WirelessHART is a wireless mesh communication standard designed to be an easy to use, reliable, and interoperable wireless mesh sensor protocol. WirelessHART operates in the 2.4GHz ISM radio band and it utilises IEEE 802.15.4 compatible DSSS radio with channel hopping on a packet basis.

WirelessHART consists of three main elements: a WirelessHART Field Device (WFD), connected to the Process or to Plant Equipment; WirelessHART gateways, which enable communication between host applications and WFD's; and a WirelessHART network manager, which is responsible for configuring the network, scheduling communication between WirelessHART devices, management of the routing tables, and the monitoring and reporting the status of the WirelessHART network (Lennvall et al. 2008).

1.2.4.3 ZigBee Network Standard

ZigBee is a low power, low data rate, low cost wireless communication standard intended to be used in home automation and remote control applications. ZigBee was designed to provide low cost and low power connectivity for equipment which needs long battery life of several months or years. ZigBee devices are expected to cover a range of 10-75 meters (m), depending on the RF environment and power output consumption required for a given application. The data rate is 250kbps at 2.4GHz, 40kbps at 915MHz and 20kbps at 868MHz.

ZigBee and IEEE have been working closely to specify the entire protocol stack, since IEEE focuses on the specification of the lower two layers of the protocol (physical and data link layers), and ZigBee Alliance seeks to provide the upper layers of the protocol stack for interoperable data networking, security services, and a range of wireless home and building control solutions. ZigBee standard supports different topologies (mesh, star, and cluster-tree), as shown in Figure 1-5 (Ergen, 2004).

ZigBee is similar to Bluetooth but it is simpler, since it has a lower data rate, and spends most of its time snoozing. This is a very good characteristic of the ZigBee nodes, as it enables each node to work for six months to two years on just two AAA batteries.

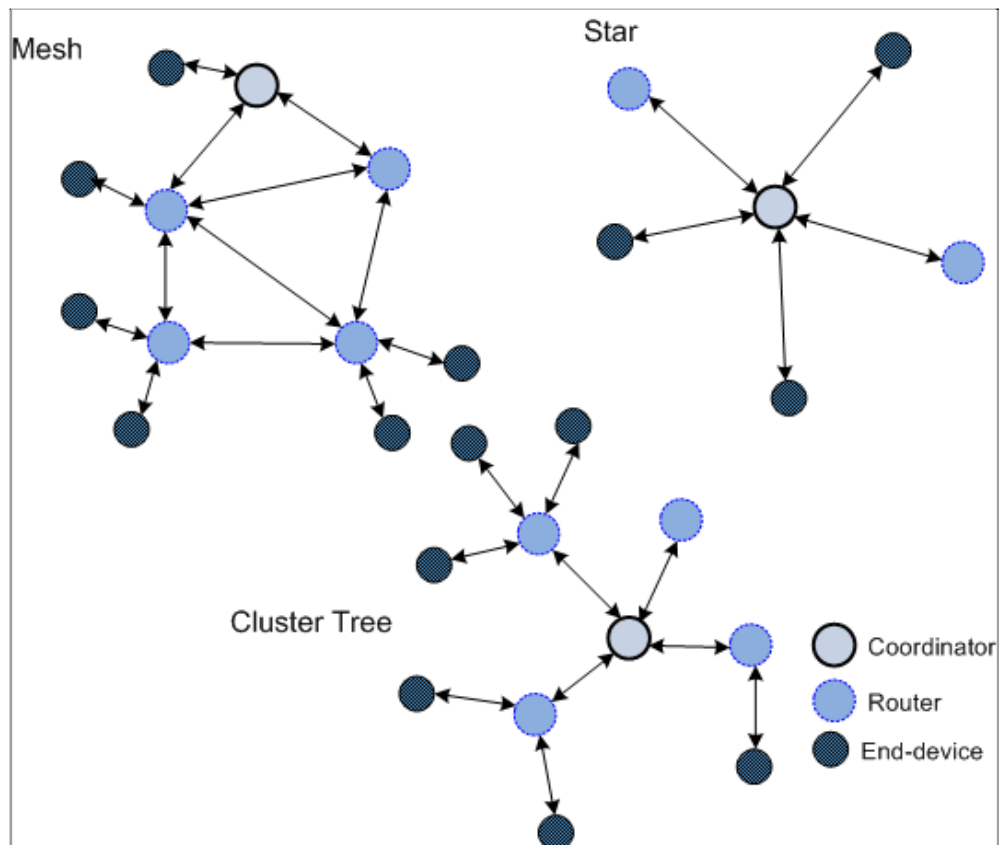

Figure 1-5: ZigBee network topologies

It is important to distinguish ZigBee from IEEE 802.15.4 network standard, since IEEE standard 802.15.4 describes the specification for radio PHY and MAC layers at 2.4 GHz, 868 MHz and 915 MHz. IEEE standard 802.15.4 aims to offer the fundamental lower network layer of WPAN, which focuses on low cost and power-consumption. ZigBee network performs three main roles: coordinator, router, and end-devices.

- ZigBee Coordinator (ZC): only one of these is required for each ZigBee network. It has a unique PAN ID and channel number. It initiates network formation. Acts as 802.15.4 PAN coordinator (FFD), and it may act as router once a network is formed.
- ZigBee Router (ZR): this is an optional network component. It may associate with ZC or with previously associated ZR. Acts as 802.15.4 coordinator (FFD), and participates in the multi-hop routing of messages.
- ZigBee-End Device (ZED): this joins ZC or ZR, which is an optional network component, acts as 802.15.4 end device (RFD). It is utilised

for very low power operations, and does not allow association or participate in routing.

1.2.5 Tracking Applications

Location based systems have been an issue in the area of mobile communications for many years. A location based system includes a service provided by a service provider that employs the available location information.

The potential applications of WSN's include environmental monitoring, military surveillance, search-and-rescue, and tracking soldiers and cars as depicted in Figure 1-6. Target-tracking applications have been widely deployed for military area intrusion detection and wildlife animal monitoring. Tracking mobile targets through WSN was initially investigated on 2002 (Shorey et al. 2006).

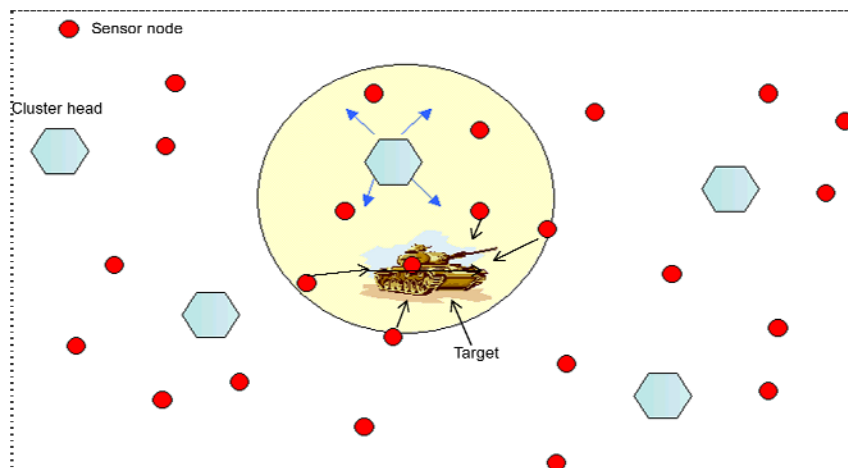

Figure 1-6: A tracking application

The node localisation and tracking applications through WSN have received much attention recently, focused on the need to achieve high localisation accuracy without incurring a large cost, form factor and power-consumption per node. This is because:

1. In several applications, the location itself is the information of interest.
2. Transferring sensors' measurements without knowing the position for each one is useless.
3. Several routing protocols are based on the locations of sensor nodes.
4. It is important to form clusters, as location information can be used to define a partition in the network.

5. Localisation systems can be used to determine the quality of coverage. If sensor node locations are known, the network can keep track of the extent of spatial coverage (Krishnamachari, 2005).

1.3 Problem Overview

One of the most challenging and interesting research areas in WSN is tracking mobile targets, as a tracking issue is not the prime task of sensor networks. Therefore, there is a great demand for light-weight localisation technique, which does not require any additional hardware and is a power efficient. The challenges of tracking a target in a sensor network have received significant attention in recent years. A tracking algorithm designed for sensor networks should be: (1) accurate - it should work with accuracy in different environments; (2) energy efficient - it should require little computation, especially in terms of communication; (3) robust - it should not depend on noise and movement of the target; (4) reliable - it has to be tolerant to node failures. In this section, the tracking problem from two different aspects is discussed: localisation accuracy and power-consumption.

1.3.1 Localisation Technique

A wide range of localisation technologies have been used for several tracking applications, such as infrared, ultrasound, Global Positioning System (GPS) and Radio Frequency (RF). These offer efficient localisation solutions in terms of accuracy. However, attaching additional hardware (such as a GPS receiver, ultrasound, or Infrared device) to each sensor and target node is not the ideal solution for several reasons:

- Cost: adding supplementary hardware to hundreds or thousands of nodes is a highly inefficient solution in terms of cost.
- Power-consumption: the additional hardware requires additional power-consumption.
- Inaccessibility: GPS and infrared signals cannot go through walls.
- Form factor: the sensor node has the feature of small size. Attaching extra hardware would increase the sensor size.

On the other hand, Received Signal Strength (RSS) techniques offer cost-effective systems and reasonable localisation accuracy in outdoor environments, but are affected by obstacles and walls in indoor environments, and for this reason RSS based tracking approaches cannot be deployed in noisy environments.

1.3.2 Power-consumption

As the most challenging concern in designing sensor networks is limitation in energy, many research efforts aim at enhancing the energy efficiency of different aspects of the networks. In WSN, energy has three main consumers: signal processing, data transmission, and hardware operations. Consuming less energy in the tracking applications is a primary objective in designing WSN applications, as each sensor node is usually supported by batteries which could be difficult to replace. One of the critical technical issues which must be addressed in developing sensor networks for object tracking applications is the energy conservation. A few studies focused on the data aggregation concept (Ditze et al. 2008, He et al. 2008, and Vaidyanathan et al. 2004) for tracking applications using WSN's. Thus, the research challenge is how to reduce the communication and power-consumption for tracking applications when deployed for WSN applications.

Therefore, it is of interest to design and implement an RSS based localisation approach for indoor tracking applications, and it is essential to investigate several energy-efficient approaches for tracking applications through WSN's.

1.4 Research Objectives

The main aim of this thesis is to improve tracking efficiency in terms of power-consumption, and localisation accuracy for tracking systems based on ZigBee WSN's. The specific research objectives associated with achieving the research aim are as follows:

- Research the current relevant literature to obtain a better understanding of the topic.
- Propose and design several localisation methods to improve the localisation accuracy for RSS based approaches, based on the earlier analysis of existing RSS based systems for use with empirical evaluation.

- Propose a decentralised tracking system for WSN to reduce the total number of messages transmitted over the network.
- Propose a ZigBee based tracking approach for locating the positions of multiple mobile targets simultaneously.
- Propose an energy-efficient tracking system for WSN in order to reduce the power-consumption required for tracking applications.
- Implement the proposed localisation methods on real sensor nodes to test the efficiency in terms of cost and accuracy.
- Use a simulator to evaluate and compare the performance of the proposed power-efficient tracking and decentralised tracking approaches.
- Test the approaches proposed in this thesis by publishing the implemented work in refereed conference proceedings and academic journals.

1.5 Main Contributions of the Thesis

The contribution of this thesis lies in three folds. Firstly, the localisation accuracy is considered. The localisation accuracy has been improved for RSS based localisation systems through designing and implementing two localisation approaches: (a) A triangulation based approach is proposed to estimate the mobile target's location where walls and obstructions exist in the tracking area. This approach is published in (Alhmiedat and Yang, 2008b). (b) A fingerprinting localisation approach is proposed in Chapter 4. The proposed system offers low localisation error (1 to 3.5 m), and requires a shorter period of time for the offline phase than the existing fingerprinting approaches.

Secondly, a ZigBee based tracking approach is implemented in order to offer reasonable localisation accuracy for tracking multiple mobile targets where the density or router and end-device nodes is low. The proposed system offers low power-consumption, as it is deployed using the full roles for ZigBee network standard. A time management method is proposed and evaluated in Chapter 6 to reduce the possible interference with beacon nodes, to reduce the localisation error. This approach is published in (Alhmiedat and Yang, 2009).

Thirdly, the power-consumption issue is studied in this thesis. Two power-efficient solutions have been proposed for tracking applications in order to reduce the amount of energy consumed during the tracking process, and hence increase the longevity of sensor nodes. (a) A decentralised localisation approach to track a high number of mobile targets is proposed. The implemented approach aims to reduce the power needed to track multiple mobile targets in WSN by grouping the mobile targets set in the same transmission range. This approach is published in (Alhmiedat and Yang, 2008a). (b) An energy-efficient tracking system to track mobile targets in WSN. The proposed approach is based on implementing a new data aggregation approach and integrates it with a simple prediction approach. The proposed approach offers reasonable localisation accuracy, while achieving lower power-consumption than the existing approaches.

1.6 Thesis Layout

The rest of the thesis is organised as follows: in Chapter 2, the most popular localisation terminologies which have been widely deployed in tracking and localisation systems are presented. The main issues to be taken into account before designing and implementing a localisation system are mentioned. Tracking and localisation systems are categorised into three main categories, and each is reviewed in detail.

Chapter 3 proposes a new triangulation based localisation system using RSS technique. The implemented system aims to reduce the localisation error by predicting the environmental characteristics in indoor tracking applications. The proposed approach is evaluated through measuring the localisation accuracy and communication cost, and compared with several existing approaches.

In Chapter 4, a fingerprinting based localisation approach is designed and implemented. The proposed approach aims to reduce the time needed for the offline phase, and improves the localisation accuracy. The implemented approach is evaluated based on the localisation accuracy and compared with other exiting approaches.

In Chapter 5, a new decentralised based localisation approach is proposed to reduce the power-consumption required to track multiple mobile targets in a given area. The implemented approach achieves low power-consumption for tracking a

higher number of mobile targets in a tracking area. Three approaches are evaluated and compared with the proposed approach in the same chapter.

Chapter 6 proposes a multiple mobile target tracking approach based on ZigBee network standard. The proposed approach aims to track multiple mobile targets through ZigBee when the density of router and end-device nodes is low. The implemented approach is evaluated and discussed in this chapter.

In Chapter 7, an energy efficient tracking system is proposed and implemented, to track mobile targets while offering low power-consumption and reasonable localisation accuracy. The presented work includes proposing a new data aggregation method, which is integrated with a simple prediction system. The work is implemented using NS2 simulator model, and the tracking efficiency is tested in this chapter.

Finally, Chapter 8 summarises the whole thesis, demonstrates how the stated aims and objectives have been achieved, and proposes some areas for further study.

CHAPTER 2

LOCALISATION AND TRACKING

SYSTEMS

2.1 Background

In WSN applications it is critical to accurately know the location of sensor nodes in order to report data that is geographically meaningful. Additionally, some basic middle ware services, such as routing, are based on location information. WSN applications with a high number of sensor nodes make it impractical to rely on the regular arrangement of sensors. Rather than relying on beacons or expensive GPS to localise each sensor node, each sensor node should be able self-organise their locations. Localisation and tracking techniques is still a pioneering field, with new algorithms, hardware, and applications being developed. In this chapter, the issues in localisation system design are discussed, the localisation methods are reviewed, and the most important localisation and tracking techniques are presented.

2.2 Issues in Localisation Algorithm Design

The issues that should be taken into consideration and overcome before designing an efficient tracking system for WSN are:

- Tracking accuracy - the main objective of the tracking system is providing reasonable localisation accuracy. In WSN, it is important to develop an accurate tracking system with lowest missing rate.
- Resource constraints - sensor devices are typically battery powered. This means that all processing, communication, and sensing actions are very expensive, as they dynamically reduce the lifespan of the performing node. Sensor networks are usually deployed on a large scale, with hundreds of thousands of nodes in a typical deployment. This fact has two critical consequences: the sensor nodes must be inexpensive, and easy to deploy.
- Communication costs - the total number of messages which need to be transferred in every unit of time should be minimum as much as possible. This is due to additional packets incurring an additional energy cost.
- Signal interference - interference between nodes in the same network results from collisions between packets transmitted by different nodes at the same time. This reduces the accuracy of the RSS values used for triangulation. Consequently, interference problems have to be overcome in order to achieve reasonable localisation accuracy.
- Environmental obstacles and terrain irregularities - these lead to inaccurate position estimation. Objects such as large rocks can obstruct line of sight, preventing TDOA and GPS ranging, or causing interference with radios.
- Node density - before designing a localisation algorithm, it is important to notice the algorithm's implicit density assumptions, because high node density might be prohibitively expensive, if not totally unfeasible.

These design challenges can affect tracking efficiency and accuracy. Several localisation methods used in tracking systems are described in the next section.

2.3 Localisation Methods

Several tracking approaches have been designed and developed recently (Li et al. 2006; Blumenthal et al. 2005; Small et al. 2000), each including one or more localisation methods. A localisation method is the way which can be applied to compute the final coordinates of a mobile target node. Localisation methods include the following: Triangulation, Fingerprinting, Time of Arrival (TOA), and Time Difference of Arrival (TDOA).

2.3.1 Triangulation

Triangulation is the process of determining the location of a target point by measuring distances to it from known points. If the distance d can be measured between the beacon node (the node with known coordinate position location) and the target node (the node with unknown coordinate location), then a circle with radius d can be drawn, as shown in Figure 2-1. Circles intersect at one point, which is the location of the target node. A Triangulation method requires the readings from at least three beacon nodes.

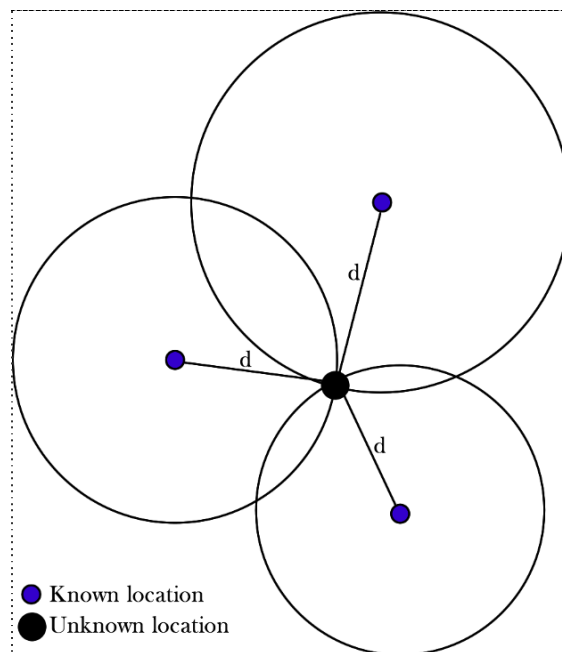

Figure 2-1: Triangulation method

2.3.2 Fingerprinting

Fingerprinting localisation method is based on the behaviour of signal propagation and information about the geometry of the building. Location

fingerprinting works by determining how the signals will be received at every grid point.

Deployment of the fingerprinting localisation method is usually divided into two phases, as shown in Figure 2-2: 1) Offline phase: this includes measuring the location for a mobile object in different coordinates, and storing the collected information in a Database (DB); and 2) Online phase: the mobile target collects several RSS values from different beacon nodes in its range and sends it to a server. The server applies an algorithm to estimate the mobile object's location (Hu and Evans, 2004).

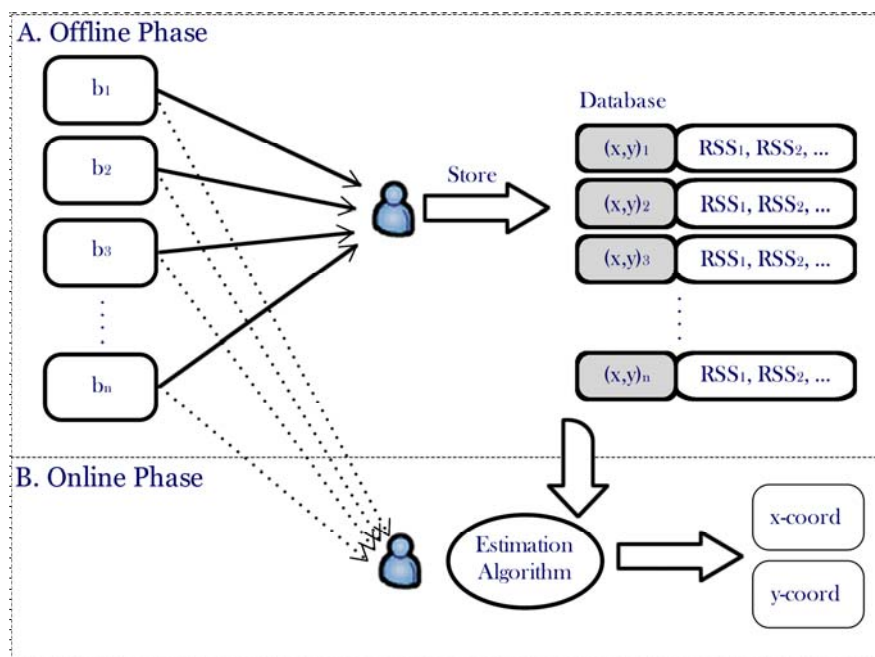

Figure 2-2: Fingerprinting method

2.3.3 Time of Arrival

TOA method is based on signal travelling time to estimate distance between a target node and beacon node. Usually, ultrasound signals are deployed in the TOA based localisation systems, as shown in Figure 2-3. TOA localisation includes measuring the TOA from at least 3 beacon nodes, and then triangulating the target's position. TOA systems require a high accuracy clock in the communication system. The distance d between each beacon node and the mobile object can be calculated based on Equation (2-1) (Ilyas and Mahhoub, 2005).

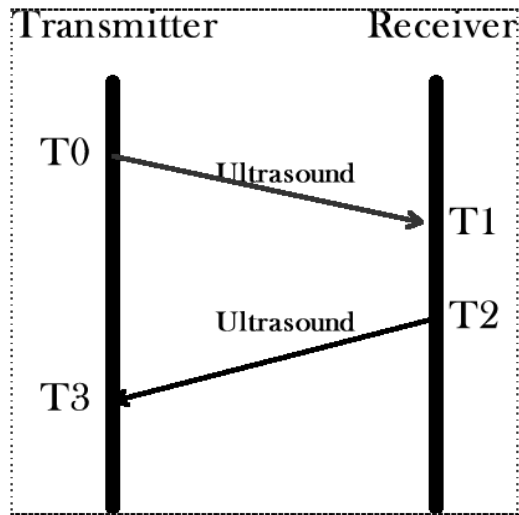

Figure 2-3: TOA method

$$d = \frac{((t_3 - t_0) - (t_2 - t_1)) \cdot v}{2} \quad (2-1)$$

where t_0 , t_1 , t_2 , t_3 , v are the transmitting time at the transmitter, receiving time at the receiver, transmitting time at the receiver, and receiving time at transmitter, and velocity of ultrasound signals respectively.

2.3.4 Time Difference of Arrival

TDOA estimates the distance based on two radio signals travelling at different speeds. The distance between the beacon node and the target node can be estimated based on measuring the difference between the transmitting time and the receiving time, as depicted in Figure 2-4. TDOA based localisation systems are more efficient than TOA, as TDOA is based on two signals travelling at different speeds. The distance d between transmitter and receiver can be calculated using Equation (2-2).

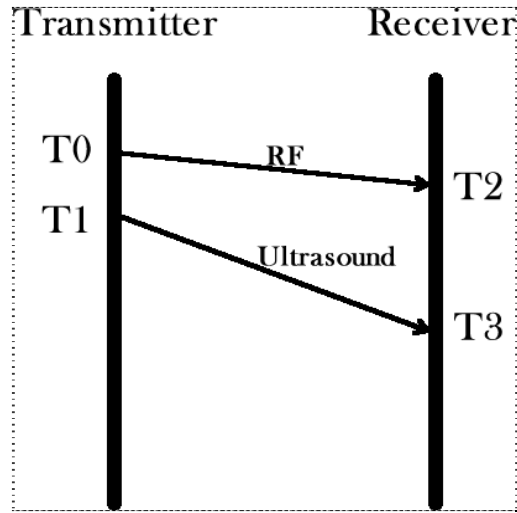

Figure 2-4: TDOA method

$$d = ((t_3 - t_2) - (t_1 - t_0)) \cdot \left(\frac{v_{RF} \cdot v_{US}}{v_{RF} - v_{US}} \right) \quad (2-2)$$

where t_0 , t_1 , t_2 , t_3 , v_{RF} and v_{US} are the transmitting time of RF signal at the transmitter, transmitting time of ultrasound at the transmitter, receiving time of RF at the receiver, receiving time of ultrasound at the receiver, the travelling speeds of RF and ultrasound signals respectively.

The main drawback behind using both TOA and TDOA are the precise time synchronization required between the sender and receiver. Deploying these systems with a large sensor network might increase the cost and power-consumption for WSN.

2.4 Localisation and Tracking Systems

The previous section covered the most important localisation methods used to estimate the final target's coordinates. In this section, the most popular localisation and tracking systems are summarised. A survey on localisation and tracking systems through WSN is presented in (Alhmiedat & Yang, 2007). The related works are categorised into three main categories as shown in Figure 2-5: Satellite, WSN, and Mobile Network based tracking systems. Each one is described in detail in the following pages.

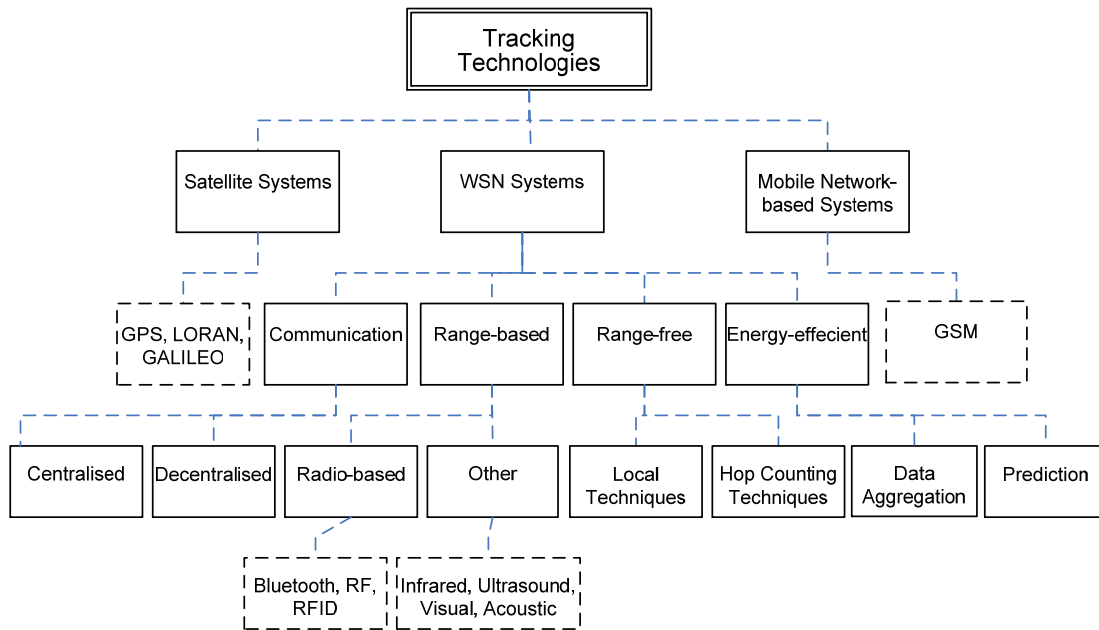

Figure 2-5: Classification of tracking technologies

2.4.1. Global Navigation Satellite Systems

Global Navigation Satellite System (GNSS) is the standard term for navigation systems based on satellites. GNSS provides autonomous geo-spatial locations with global coverage. Small electronic devices can determine their location (longitude, altitude, and latitude) to within a few meters of localisation error using time signals transmitted along line-of-sight by radio waves from satellite. GNSS includes GPS, LORAN, GLONASS, and GALILEO.

2.4.1.1 Global Positioning System

GPS is currently the most widespread outdoor positioning technique, and it is based on a set of satellites that offer three dimensional positioning with accuracy of around 3 m. These satellites have a clock set to exactly the same time, and they know their exact position from data sent from the system controllers. Each satellite transmits its position and a time signal to the receiver. The receiver can calculate the distance to each satellite and then calculate its own position. GPS based tracking techniques have been deployed with WSN systems as in (Paschos et al. 2005) and (Niculescu and Nath 2003).

2.4.1.2 LORAN

LORAN refers to LOng Range Aid Navigation, which is a radio navigation system based on low frequency radio transmitters that utilizes multiple transmitters to compute the location and speed of the receivers. LORAN system is deployed in many countries including the USA, Japan, and several European countries. The localisation method is based on the principle of the time difference between the receipts of signals from a pair of radio transmitters (Kolodziej and Hjelm, 2006).

2.4.1.3 GLONASS

GLObal NAVigation Satellite System (GLONASS) is a radio-based satellite navigation system that was developed by the Soviet Union. It is operated now for the Russian government by Russian Space Forces. GLONASS system consists of 21 operational satellites plus three spares. Like the GPS, each GLONASS satellite transmits a signal that includes a number of components: two-L-band carries, C/A code, and a navigation message. However, unlike GPS, each satellite transmits its own carrier frequencies using different bands (1,602-1,615.5 MHz for L1, and 1,246-1,256.5 MHz for L2), to avoid interference with radio astronomers and operators of low-Earth orbiting satellites. GLONASS is an alternative and complement to the GPS navigation systems (El-Rabbany, 2002).

2.4.1.4 GALILEO

GALILEO is a GNSS currently being developed by the European Union (EU) and European Space Agency (ESA). GALILEO project is an alternative and complement to the American GPS and the Russian GLONASS. GALILEO system consists of 30 medium-earth orbiting satellites evenly distributed over three orbital planes at an altitude of about 23,000 km. Unlike GPS and GLONASS, GALILEO will provide two levels of services: a free-of-direct-charge service and a chargeable service which offers additional features (El-Rabbany, 2002).

GPS and LORAN are very successful localisation systems over a wide area, but are ineffective in built-up areas due to loss of line of sight, in addition to signal blockage, fading and shadowing. GALILEO system will improve the coverage of open access in urban environments, and will enhance the localisation accuracy. However, deploying satellite systems with sensor networks might increase the

sensor device cost and size, as each sensor device has a small physical size and low cost features. In addition, these systems cannot be used in indoor environments.

2.4.2 WSN Localisation Systems

The previous section covers the most popular satellite navigation systems. The issue of tracking mobile targets through WSN is enthusiastically researched and addressed in several works (Blumenthal et al. 2007; Jang and Skibnewski, 2007; Jung and Sukhatme, 2001). The existing approaches focus on diverse parts of tracking in sensor networks, such as localisation methods, real-time implementation aspects, power-consumption issues, and network standards. In this section, the WSN based localisation systems are considered, categorised them into four main categories: communication between nodes, range-based, range-free, and energy-efficient systems.

2.4.2.1 Communication between Nodes

Localisation systems can be categorised based on the communication between nodes into two main types: centralised and decentralised systems. Figure 2-6 shows the main concept for both systems. Centralised localisation techniques involve computing the target's location based on transmitting the localisation information to a central node. However, decentralised localisation techniques do not require transmitting every single packet to a central node, and only require transmitting the latest coordinates of mobile targets. Therefore, decentralise techniques offer low power consumption than centralised techniques. According to Benavoli and Chisci (2007), the centralised based system has two advantages over the decentralised one: firstly, the nodes are not required to have processing capabilities; and secondly, the irregularity and mobility of the mobile target requires frequent data communications among beacon nodes to have good localisation accuracy, and this destroys the main advantage of decentralised localisation systems.

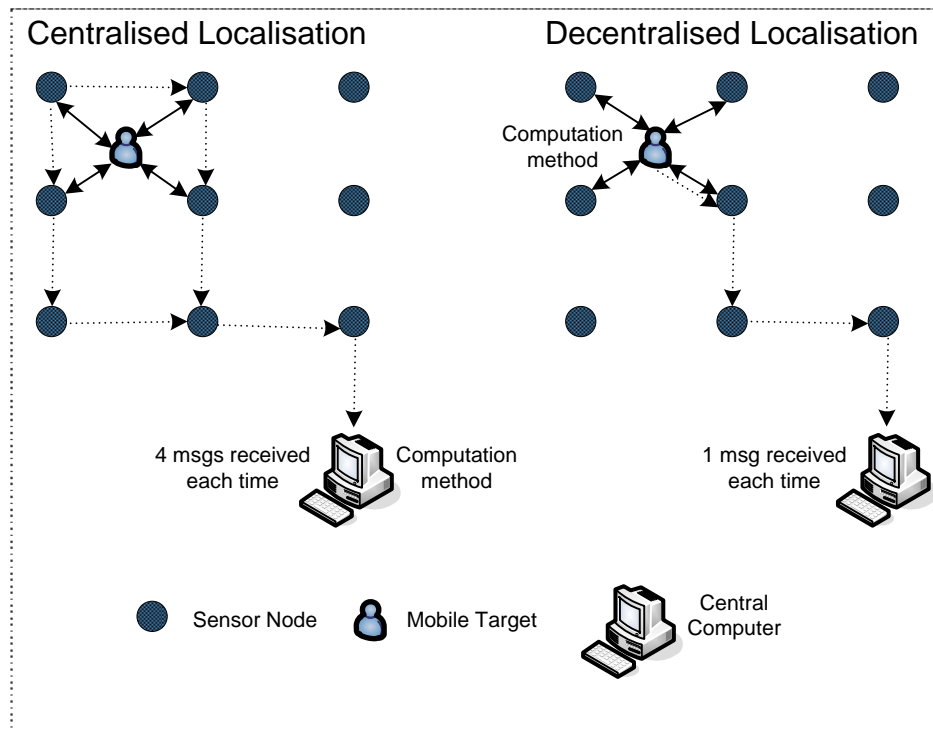

Figure 2-6: Centralised and decentralised tracking systems

The works proposed in (Alippi and Vanini, 2006; Sugano et al. 2006; Doherty et al. 2001) include a RSS based localisation system through centralised communication among sensor nodes.

Decentralised or distributed localisation techniques include that each sensor node is responsible for determining its location with only limited communication with nearby limited nodes. Lazos et al. (2005) proposed a hybrid technique called ROBust Position Estimation (ROPE), which allows sensors to locate their locations without recourse to a centralised computation facility. ROPE provides a location verification mechanism that verifies the location claims of the sensors before data collection. ROPE allows the sensors to estimate their own location without the assistance of a central authority.

Shang et al. (2003) proposed a MDS-MAP technique for calculating the positions of nodes with only basic information that might be already available. MDS-MAP technique involves starting with the given network connectivity information, and an all-pairs shortest-paths algorithm is used to assess the distance between each possible pair of nodes.

The proposed approaches in Bulusu et al. (2002) and He et al. (2003) are decentralised based localisation systems, because all the communication and processing required are undertaken in the sensor node itself.

The presented centralised approaches require transmitting data to a central node in order to calculate the location of the target node. Transmitting data to a central computer is quite expensive because the power supply for each node is limited, and the long-range multi-hop data transmission is costly and usually inefficient. Consequently, communication with a centralised computing facility is expensive, because the each sensor node has a very limited power supply. Furthermore, sending time series data within the network introduces latency, and it also consumes energy and network bandwidth.

Decentralised localisation systems require less communication between nodes and hence reduce the power-consumption of WSN. However, decentralised localisation systems require attaching hardware (Personal Digital Assistant (PDA) or laptop) to each mobile target in order to gather the localisation information from beacon nodes, compute its location, and transmit its current position to a central computer.

2.4.2.2 Range-based

Range-based localisation techniques work based on using absolute point-to-point distance estimates (range) or angle estimates. Range-based technique can be divided (based on the localisation technique) into two main types: radio-based and other techniques, which are based on other mediums to measure the distance.

Radio-based techniques are based on the use of radio waves to determine the target's location, and include Radio Frequency (RF) based, Bluetooth, and Radio Frequency Identification (RFID) based localisation techniques.

Radio Frequency based

Radio signal information from a wireless transmitter can be used to estimate the location for target nodes in two ways: the first uses the signal propagation model to convert signal strength (SS) to a distance measurement, using previous knowledge about the beacon nodes' coordinates, and deploys a geometry method to compute the location for target nodes. This is known as a triangulation localisation

method. The second method uses the behaviour of signal propagation and information about the geometry of a building to convert RSS values into distance values; this is known as a fingerprinting localisation method.

To turn to the first of the RF based approaches, triangulation methods involve measuring the RSS levels to estimate the distance to multiple known locations. The proposed work by Terwilliger et al. (2002) includes a localisation system called Ferret, and was based on two main techniques: Potentiometer, and RSS based. Ferret system consists of three main components: (1) the potentiometer localisation sub-system; (2) the RSS localisation sub-system; and (3) an environment calibration tool. In the Potentiometer technique, each target node transmits messages to the beacon node at the lowest power level and listens for replies. As soon as the target node gets three replies from different three beacon nodes, it forwards its data to the base station for computing its location. However, in the RSS method, each target node sends out a series of five signals using full transmission power. Then the target node records the identification number and the RSS values for all received packets. Finally, it computes the average of RSS for each neighbour that it heard from and identifies the three closest neighbours.

Radio-based localisation techniques offer reasonable localisation accuracy while achieving low-cost sensors. Paschos et al. (2005) proposed a localisation approach for WSN. The proposed system can be deployed using a small number of beacon transceivers, with each beacon having a GPS device to calculate its position.

Blumenthal et al. (2007) proposed a ZigBee weighted centroid localisation algorithm to locate devices with unknown positions in WSN. The proposed algorithm is RSS based, and depends on the distance and the characteristics of the sensor node's receivers. Reichenbach et al. (2006) proposed novel optimizations for coarse grained localisation systems with centroid determination. This work was similar to that of Blumenthal et al. (2005). Both works are RSS based systems and focus on computing an optimal transmission range for all beacon nodes to reduce total power-consumption. The optimal transmission range is determined based on the distribution of the sensor nodes in the tracking area.

In Reichenbach et al. (2006), a centroid localisation system in combination with RSS technique was introduced. The proposed system was deployed using

methods like frequency diversity and averaging multiple measuring data in order to reduce the localisation error. The implemented system achieved a small localisation error of 14% for 69% of all test points. However, this was conducted in a small experimental area (300 × 300 cm).

The second RF based approach to be considered is fingerprinting based. Several RSS based localisation systems have been deployed based on the fingerprinting localisation method. The offline phase for fingerprinting based localisation systems can be achieved in one of two ways; DB based or Neural Network (NN) based system. In the DB based systems, the RSS values are collected from the distributed beacon nodes at several reference points and store this information in DB. On the other hand, NN based systems include collecting RSS values from beacon nodes at several reference points and then feeding this information to train the network with the actual coordinate locations.

The systems proposed by Li et al. (2006) and Small et al. (2000) include a WLAN based indoor localisation system using fingerprinting technique. The developed approaches are based on collecting RSS values from several access or beacon nodes distributed over the tracking area and storing them in a DB. The mobile target estimates its location by contrasting the RSS values collected from beacon nodes and the RSS values stored in the DB.

RADAR is a well-known tracking system outlined in the study of Bahl and Padmanabhan (2000), which operates by recording and processing information regarding the SS at multiple base stations in order to provide overlapping coverage of the area of interest.

A hybrid localisation approach using WLAN was proposed by Li et al. (2005). This system includes two main stages: firstly, a fingerprinting method, with a fast training phase to obtain the location for the mobile target, indicates which room the mobile target is in; and secondly, a tri-alteration is used to compute the mobile target location precisely. It has been shown that the proposed hybrid system is more accurate than the tri-alteration one. However, it offers lower localisation accuracy than the fingerprinting method.

As previously mentioned, NN can be deployed in the offline phase in order to train the network based on the collected values from several reference points. NN is

a mathematical model or computational model that attempts to simulate the structure of biological NNs. It includes a network of neurons and tries to imitate the way a human brain works. NN can be used with the fingerprinting localisation approach in order to reduce the time needed in the offline phase. The work presented by Ahmad et al. (2006) includes an indoor localisation system based on a modular, multi-layer perceptron NN model. Three NN modules were designed in order to cover the absence of signals from access points. The proposed work by Battiti et al. (2002) includes a fingerprinting based localisation system with localisation accuracy of 3 m. One-Step Secant (OSS) method is used in the learning phase based on the collecting 200 sample points. OSS offers low memory requirements and efficient estimation. It was approved that the architecture 3->8->2 apparently offers the best estimation values.

Shareef et al. (2008) compared the performance of three different families of NNs for localisation applications using WSN: Multi-Layer Perceptron (MLP), Radial Basis Function (RBF), and Recurrent Neural Networks (RNN). It has been shown that the localisation method using RBF is the best choice, as it offers high localisation accuracy and minimal computational and memory requirements for embedded systems.

Bluetooth

Bluetooth is a short-range communication standard that allows various wireless devices to communicate over short ranges, enabling point-to-multipoint data and voice transfer. Bluetooth based localisation systems have been applied widely in the industrial, scientific, and medical fields.

One of the goals of applying Bluetooth networks is to offer more accurate and lower-cost indoor localising. The system proposed in the study of Rodriguez et al. (2005) presents a Bluetooth based localisation system for locating mobile devices indoors. The system includes averaging the RSS values from several Bluetooth access points. The signal energy is measured by each mobile device and is transmitted to a central server to triangulate the mobile target's location.

Radio Frequency Identification

RFID is an established data carrying and automatic identification technology, which is a less sophisticated form of localisation. RFID tags can be used in many

applications, such as location determination. For instance, RFID positioning systems are very common in airport baggage transport systems and mail processing plants. The localisation accuracy for RFID systems depend on the number of placement of RFID scanners.

Commonly, a RFID based system includes three main components: (a) the transmitter; (b) a transceiver with decoder; and (c) an RFID tag automatically programmed with unique information.

One well-known 3-D RFID based localisation system is SpotOn. SpotOn deploys an aggregation algorithm for three-dimensional positioning system based on radio SS analysis. A small, low-cost hardware was designed and built to serve as an object location tag. The target tags can be located by homogenous sensor nodes, with no need for central communication (Hightower et al., 2000).

RFID technology can be deployed in robot navigation systems. Kurth et al. (2003) deployed RFID tags for robot localisation and mapping. The proposed system uses TOA type of information to measure the distance between the detected tags and the reader device.

Radio-based localisation systems offer reasonable localisation accuracy. However, RSS values can be affected by walls and obstacles, which may reflect and propagate the signals, therefore offering a non-linear transformation between the RSS and the location. Due to these limitations, deploying RSS based localisation systems in indoor environments becomes a complicated problem which is hard to engineer using classical mathematical models.

Bluetooth based localisation systems satisfy many of the localisation requirements, as Bluetooth technology is integrated in every-day items, offers reasonable accuracy, and is relatively inexpensive. However, localisation systems based on Bluetooth technology are inadequate for positioning systems as the Bluetooth hardware is too restricted. The SS of a Bluetooth connection can only be acquired if the devices are paired. Pairing devices requires too much time, and limits the network size to seven devices.

RFID based localisation systems offer high positioning accuracy in both indoor and outdoor environments. RFID tags are cheap in cost, and small in size.

However, RFID readers do not have a communication network that supports exchange of location information, in addition to their high costs.

Other range-based localisation techniques include infrared, ultrasound, acoustic, and visual based systems.

Infrared

Infrared beam consists of an electromagnetic signal of a wavelength which is longer than that of visible light, but shorter than radio waves. Infrared technology has been used in several tracking applications. Maeda et al. (2003) developed a system to track people inside buildings based on a pair of stereo cameras, an orientation sensor, and an Infrared Data Association (IrDA) signal decoder. Markers emit unique ID using IrDA test frame protocol. The ID is decoded by the IrDA signal decoder and then tracked based on coordinates read out from the orientation sensor and stereo camera.

Active Badge System is considered to be a significant contribution to the field of location-aware systems. Each target person has to wear a badge, which emits a unique Infrared (IR) signal every 10 seconds. Sensors placed at several known locations within the building pick up the transmitted signals and send them to a base station (Want et al. 1992).

Ultrasound Signal

Ultrasound system operates at low-frequency bands (40 kHz). Ultrasound signal gives a good level of precision for location-sensing at a low propagation speed of sound (343 m/s). The main benefits of ultrasound devices are that they are simple and inexpensive. However, as with infrared signal, ultrasound signal does not penetrate walls.

Priyantha et al. (2000) proposed a location support an indoor tracking system called Cricket. Cricket system involves deploying small beacons in an area of interest to distribute geographic information to listeners. A small listening device, which is able to listen to messages from beacon nodes, is attached to each mobile target and beacon node. Cricket system combines with RF and ultrasound to enable a listener to determine the distance to beacons, from which the nearest beacon can be more unambiguously inferred.

The model proposed by Ward et al. (1997) includes a tracking project which is able to locate a person who wears a badge at any place. These badges use ultrasound based technology to transmit signals to the receiver installed at different beacon points. Three receiver nodes are needed each time to measure the time propagation of the ultrasound from the bat.

Acoustic based

Acoustic based localisation systems include computing the distance between a beacon node and a target node based on acoustic behaviours. These techniques have received much attention recently, as they offer accurate and precise localisation information. Figure 2-7 depicts an acoustic sensor used to localise and track a mobile target based on acoustic modality. Kushwaha et al. (2005) proposed a mobile acoustic reference based sensor node localisation method. The proposed technique is passive in that the sensor nodes themselves do not need to generate an acoustic signal for ranging, and only the mobile target needs to emit acoustic signals, and it was especially developed to work in such acoustically reverberant environments.

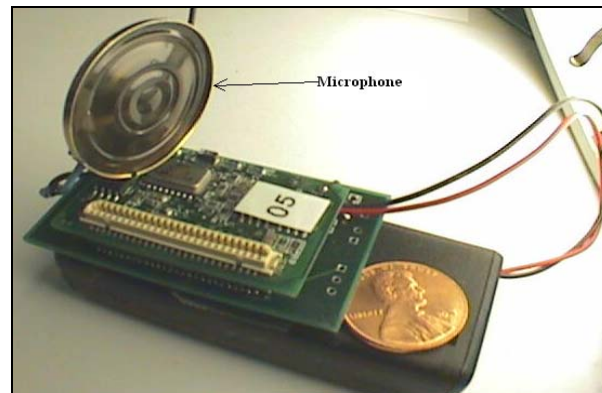

Figure 2-7: Acoustic based localisation sensor with microphone

Mechitov et al. (2003) proposed a cooperative tracking technique to track the mobile targets through WSN. The implemented system relies on distributed sensing to identify the mobile target and determine its approximate position, and it involves the following steps: firstly, each beacon node records the duration for which the object is in its range; secondly, neighbouring nodes exchange these times and locations; thirdly, for each point in time, the object's estimated position is computed as a weighted average of the detecting nodes' locations; and fourthly, a line fitting

algorithm is run on the resulting set of points. The cooperative tracking technique is useful for short-term extrapolation of the target's path.

Whitehouse and Culler (2003) proposed an ad-hoc localisation system called 'Calamari' which aims to consume as few resources as possible. Calamari method estimates the distance between sensor nodes using a fusion or RSS method and acoustic Time Of Flight (TOF).

Tracking mobile techniques based on sensing modality have been used widely. Galstyan et al. (2004) proposed an online distributed algorithm in which sensor nodes use geometric constraints induced by both radio connectivity and sensing to decrease the uncertainty of their positions. The sensing constraints involve sensing the moving target, and this is usually tighter than connectivity based constraints, which leads to decrease localisation error over time. The proposed technique is applicable for two different distance sensing models: radial binary detection and distance bounding estimation. The radial binary detection model involves detecting whether or not there is a target within the range of a sensor. On the other hand, in the distance-bound estimation model, each sensor can estimate bound on the distance within which the target must be present. Figure 2-8 depicts a tracking system model, based on acoustic sensor nodes, ascertaining the position of some birds based on their song.

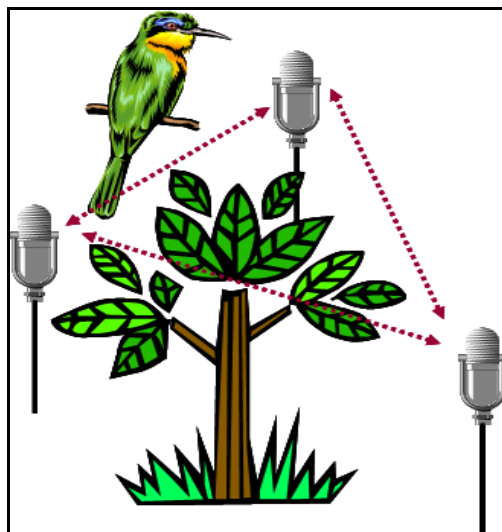

Figure 2-8: Tracking system based on acoustic behaviours

Gupta and Das, (2003) developed a technique for detecting and tracking mobile targets through WSN area, and it involves only simple computation and

localises communication only to the nodes in its vicinity. The proposed approach includes the following steps: detecting the presence of the target, determining the direction of motion of the target, and alerting the proper nodes in the network. Three beacon nodes are required to triangulate the mobile target's location. The proposed technique was deployed efficiently with a low-cost sensor network test-bed.

Ramanathan, (2002) developed the approach of location-centric computing to find the presence of a certain type of mobile vehicle and track its movement within the wireless sensor area. It is based on collaboration between sensor nodes in a certain area, and not among an arbitrarily specified set of sensors.

Aslam et al. (2003) proposed a binary sensor method, which involves that each sensor's value is converted reliably to one bit of information only, whether the mobile target is moving towards or away from the sensor. The proposed approach involves each individual sensor node having sensors that can detect one bit of information and send this to the base station.

Visual based

Visual based localisation systems are a natural sensing modality for tracking applications, as the target person does not require carrying or wearing any special devices. The proposed system in Maeda et al. (2003) includes tracking mobile targets based on IrDA signal decoder, and a pair of stereo cameras. The proposed system can be deployed indoors, and measure the position and orientation of a target 30 times per second.

Jung and Sukhatme, (2001) developed a tracking system that relies on attaching a camera and laser rangefinder on each sensor node. The vision based tracker finds the existence and direction of coloured targets using a camera device, then estimates the distance to the target using a laser rangefinder. The developed tracking system was tested with stationary embedded sensors and mobile robots.

Infrared, ultrasound, acoustic, and vision based tracking systems are efficient in terms of localisation accuracy. However, these systems suffer from the following drawbacks:

- Ultrasound and infrared signals have limited communication range.
- Require significant installation and maintenance cost.

- Perform poorly in the presence of walls and obstacles; they require line of sight.
- Deploying these systems with WSN introduces additional effort and cost to each sensor device.

2.4.2.3 Range-free

Researchers have sought alternative range-free solutions to cover the gaps in range-based localisation systems. A range-free localisation technique is based on the regular radio modules as basics for localisation, and depends only on the content of the received message. Therefore, there is no hardware required for such techniques. Range-free localisation techniques are regarded as cost and power effective, and provide adequate solutions for localisation in WSN. According to Hua and Evans (2004), range-free localisation techniques can be divided into two main types based on a density of nodes: local and hop-counting techniques.

Local techniques

Local techniques rely on a high density of beacons, so that every sensor node can hear from several beacons. Bulusu et al. (2000) proposed a centroid localisation technique for low-cost sensor devices which do not have GPS receiver, based on the spherical radio propagation assumption. Each target node estimates its location by measuring the centre of the location of all nodes it hears. The main advantage of the proposed approach is that there is no need for any coordination between beacon nodes. The proposed system offers reasonable localisation accuracy outdoors.

He et al. (2003) proposed A Point In Triangle (APIT) range-free localisation technique, which needs a heterogeneous network of sensing devices. The theoretical method includes narrowing the potential area in which a target node resides; this process is called the Point-In-Triangulation (PIT). The target node chooses three beacon nodes and then tests whether it is inside the triangle formed by connecting these three beacon nodes. APIT algorithm can be divided into four steps: 1) Reference exchange; 2) PIT Testing; 3) APIT aggregation; and 4) Centre of gravity calculation. APIT yields its best results when irregular radio patterns and random node placement are considered. APIT algorithm is depicted in Figure 2-9.

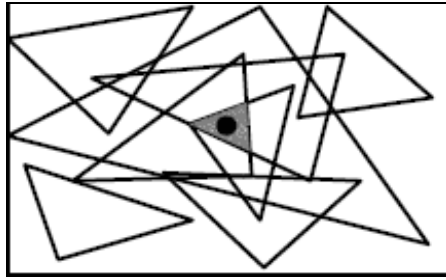

Figure 2-9: APIT Technique

Bulusu et al. (2001) focused on the localisation of the sensor nodes based on reference placement, as the reference placement has a critical impact on the overall quality of localisation. Two techniques were proposed: HEAP increment reference placement algorithm; and STROBE adaptive density algorithms. HEAP algorithm includes an incremental deployment of additional beacons, and it is applicable to low density regimes of beacons deployment. STORBE algorithm selectively switches off some beacon nodes to extend the system life time, and maintain uniform localisation granularity.

Hop Counting

Hop counting techniques rely on flooding a network, which works efficiently in a network where beacon node density is low. Niculescu and Nath (2003) proposed a DV-HOP technique that includes each beacon node, maintains a counter denoting the minimum number of hops (number of nodes between the source and destination nodes) to target node, and then updates the counter based on messages received. The proposed work addressed the problem of self-locating nodes in the field, and designed an Ad hoc Positioning System (APS). APS is a localised and distributed system, which does not require special infrastructure or setup, offers global coordinates, and needs re-computation only for the moving nodes.

Nagpal et al. (2003) proposed an algorithm which takes the advantages of the ad hoc WSN's to find position information. The proposed algorithm is a self-organised global coordinate system, which relies only on distributed simple computation and local communication, with no need to attach extra hardware.

Blumenthal et al. (2005) devised a new localisation solution to reduce the error of the weighted centroid localisation algorithm that depends on hop count determination. It was assumed that the transmission range for each sensor is represented as a single circle.

Range-free localisation techniques have been investigated and addressed in several works in order to replace the range-based localisation techniques, which are power consuming and require additional hardware. Therefore, range-free localisation techniques are power-efficient, and do not require any additional hardware.

Local techniques compute the location of target nodes based on a high density of beacons, since each target node can hear from several beacon nodes in order to calculate the location. Their main drawback is that local techniques must be deployed in an area with high density of beacon nodes. On the other hand, hop counting technique offers realistic localisation information, even if deployed in an area with a low density of beacon nodes. However, both approaches (local and hop counting) offer a low level of localisation accuracy compared with range-based localisation systems.

2.4.2.4 Energy-efficiency

The issue of power-consumption is critical for designing a tracking application for WSN's. Data aggregation and prediction methods can reduce the power-consumption for the whole WSN. In this section, energy-efficient systems are divided into two: data aggregation and prediction methods.

Data Aggregation based

Several existing studies focused on data aggregation methods for WSN. Ditzel et al. (2008) investigated four diverse aggregation strategies for tracking applications, concentrating on the trade-offs between the amount of communication in the network and tracking accuracy. The proposed system considered the results of a study on the effects of data aggregation for target tracking in WSN's. The implemented strategies aimed to reduce the total number of messages transmitted over the network while offering a reasonable tracking accuracy.

He et al. (2006) designed a data aggregation technique for real-time surveillance applications focusing on timeliness, power-consumption, and information availability. It was agreed that tracking solutions with data aggregation method can reduce the amounts of energy consumed. Three aggregation methods were presented by Vaidyanathan et al. (2004); in-network, grid based, and hybrid

scheme. The proposed hybrid scheme tries to combine the features from both previous techniques, and it offers low time delay.

Prediction based

Prediction based systems using WSN are actively researched and addressed in several works, such as the work of Xu et al. (2004), which investigated several basic energy saving methods for target tracking in sensor networks. A Prediction based Energy Saving (PES) method was proposed, consisting of prediction, wake up, and recovery methods.

He et al. (2006) studied several management strategies in order to ascertain the extent of the life time for tiny sensor devices for outdoor long-term surveillance. However, the proposed work by Pattem et al. (2003) includes proposing four generic sensor activation strategies for target tracking in WSN's. The proposed strategies were evaluated by measuring the performance of the tracking accuracy with respect to power-consumption.

Several data aggregation approaches have been designed recently, in order to reduce the total number of messages transmitted over the network. These approaches offer power-efficient systems in terms of cost and battery life. On the other hand, predictions systems include finding out the future location for mobile targets in order to activate the right group of sensor nodes to tracking the mobile target. The proposed prediction systems are power-efficient and offer reasonable localisation accuracy.

2.4.3 Mobile Network based Systems

One of the critical issues in cellular networks is tracking mobile clients when they are moving through the network. To solve this issue, cellular networks deploy location management techniques. Location management technique consists of two processes: location updating and paging. Location update includes the information provided by the mobile device to the network about its existing location. Paging can be carried out by the network, where it actively queries the mobile devices to locate the cell which the mobile device is located in (Kolodziej and Hjelm, 2006).

GSM is the most widespread cellular technology standard, with deployments in more than 100 countries. Several GSM based tracking applications have been

proposed to estimate the location of mobile clients, as in the works of Lamarca et al. (2005), Laitinen et al. (2001), and Laasonen et al. (2004), which include a GSM based tracking system with 100-150 m accuracy in an urban environment.

Mobile network based systems offer reasonable localisation accuracy outdoors. However, these systems cannot be deployed with wireless sensor devices due to the complicated hardware needed to be attached to each sensor device.

2.5 Summary

The aim of this chapter was to outline technical foundations of today's localisation and tracking techniques, and to illustrate the gaps in each one. Designing and implementing a tracking system poses some design challenges, such as cost and power-consumption. No specific approach is especially well-designed and implemented across the spectrum. For example, some localisation techniques require expensive hardware, such as range-based and satellite based localisation techniques. Attaching extra hardware to each sensor device increases both the power-consumption and cost.

Other techniques require deploying a high density of beacon nodes in a tracking area, such as local techniques. WSN with a high density of sensor nodes is impractical as a tracking solution. Hop counting techniques offer efficient localisation systems with a low density of beacon nodes. However, the localisation error is likely to be high. Additionally, some hop counting techniques require a spherical radio propagation assumption, which is not applicable indoors.

Some techniques require transmitting the localisation information from beacon nodes to a central computer, such as centralised localisation approaches, whereas some techniques are capable of making all calculations on target nodes themselves. Centralised localisation approaches offer high power-consumption when deployed with large sensor networks. Decentralised approaches offer lower power-consumption than centralised ones, but require high power-consumption when tracking a high number of mobile targets.

Other techniques require a way of performing off-line computation, such as fingerprinting based systems. Offline computation phase adds additional effort and cost to tracking applications. Various techniques are based on pre-positioned nodes,

as with the triangulation based localisation approaches. Data aggregation and prediction systems offer low power-consumption for tracking WSN based applications. However, these systems affect the localisation accuracy and efficiency.

Radio-based systems offer reasonable localisation accuracy in outdoor environments. Moreover, RF based systems are low in cost and power, with no requirements to attach external hardware, and the location measurements are achieved through transmitting messages between the beacon and target nodes. However, these systems achieve high localisation error in indoor environments.

CHAPTER 3

A RSS BASED TRIANGULATION APPROACH

3.1 Background and Motivation

Localisation technologies based on RSS are among the most popular and cheapest techniques, and are increasingly being adopted as a positioning solution for localising mobile targets in outdoor environments. RSS based localisation systems work by converting the SS to distance measurement. However, RSS values can be affected by walls and obstacles which may reflect and propagate the signals, thereby rendering a non-linear transformation between the RSS values and the location coordinates. Due to this limitation, deploying a RSS based localisation system in indoor environments becomes a complicated problem.

As discussed in Chapter 2, the RSS information can be used to measure the distance between the transmitter and receiver in two ways: the first uses the signal propagation model to convert SS to a distance measurement, using previous knowledge about the beacon nodes' coordinates, and deploying a geometrical method to compute the location for target nodes (known as a triangulation localisation method); the second category is based on using the behaviour of signal propagation and information about the geometry of the building to convert RSS

values into distance values (known as a fingerprinting localisation method). In this chapter, a triangulation based localisation approach is proposed. In the next chapter, a fingerprinting based localisation approach is proposed.

The triangulation localisation issue based on the RSS technique was researched and addressed in several works (Terwilliger et al. 2002; Alippi and Vanini, 2006; Blumenthal et al. 2005; Blumenthal et al. 2007). The works cited offer efficient localisation systems in terms of cost and accuracy in open environments. However, these systems have high rates of localisation error in complex environments.

This chapter proposes a novel triangulation system based on RSS technique. The presented work aims to offer reasonable localisation accuracy in indoor environments where obstacles and walls are found. The main aim of the proposed system is to predict the environmental characteristics in the tracking area to reduce the localisation error, where the density of beacon nodes is low. The presented system can detect and track the location of a single mobile target node indoors based on measuring the SS values for each packet received from beacon nodes.

3.2 RSS based Localisation Approach

The proposed approach in this chapter is based on RSS technique. In this section, the RSS and LQI functions are introduced. Next, the proposed localisation system is described in detail.

3.2.1 Received Signal Strength

RSS is a circuit to measure the strength of incoming signals at the receiver. The basic circuit is designed to pick RF signals and produce an equivalent output of the SS. The main concept behind RSS system is that the configured transmission power P_{tx} at the transmitting device can directly affect the received power P_{rx} at the receiving device as presented in Equation (3-1). According to Rappaport (1996), in Free Space transmission model, the detected SS value decreases with the distance to the sender.

$$P_{rx} = P_{tx} \cdot G_T \cdot G_R \cdot \left(\frac{\lambda}{4\pi d} \right)^2 \quad (3-1)$$

where, G_T and G_R are the gain of transmitter, and gain of receiver respectively. λ is the wavelength, and d is the distance between sender and receiver. The RSS is converted to a Received Signal Strength Indicator (RSSI), notated by R_{ss} as presented in Equation (3-2), which can be defined as the ratio of the received power to the beacon power P_{Ref} .

$$R_{ss} = 10 \cdot \left(\log \frac{P_{rx}}{P_{Ref}} \right) \quad (3-2)$$

3.2.2 Link Quality Indicator

Link Quality Indicator (LQI) represents the quality of the connection between sender and receiver. LQI measurement involves the characterization of strength and/or quality for each received packet, and the results should be reported as an integer ranging from $(0x00)_{16}$ to $(0xff)_{16}$. The strongest LQI value means the best connection quality between sender and receiver, and the lowest LQI value means the minimum quality of signal which detected by a receiver. LQI can be calculated based on Equation (3-3), and notated by L_{qi} .

$$L_{qi} = (47 - M_{ed}) \cdot 6 \quad (3-3)$$

where M_{ed} is the number of gain stages required to properly receive a single packet.

LQI is a metric of the current quality of the RSSI. As with RSS, LQI measurements can be used to estimate the location between a transmitter and receiver. The works proposed by Blumenthal et al. (2007) and Lee et al. (2008) used the LQI function to localise mobile target nodes.

3.2.3 RSS based Localisation System

A new approach is proposed here to estimate the mobile target's location in indoor environments, based on predicting the environmental characteristics using

RSS technique. In order to illustrate the relationship between the RSS and the distance, Figure 3-1 shows the SS pattern around a beacon node in an open environment, and it represents the fact, the closer to the source, the stronger signal and the higher reading. However, in indoor environments, signals encounter several environmental impacts, causing attenuation, absorption, reflection, or a combination of these factors.

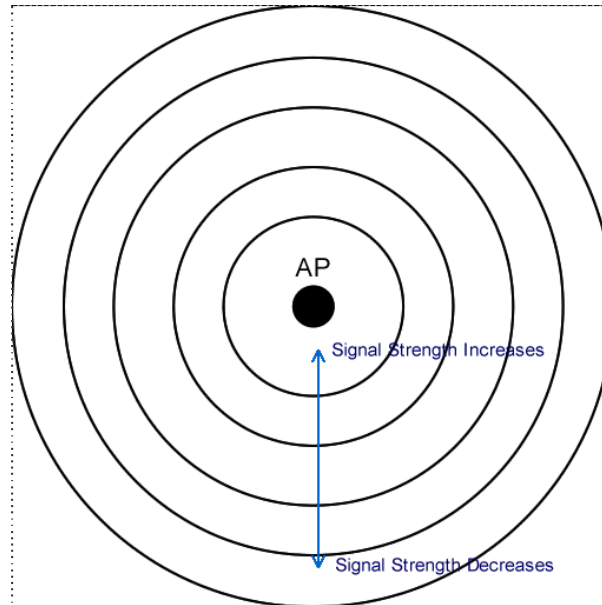

Figure 3-1: Signal strength pattern in open environment

Figure 3-2 depicts the distorted SS pattern around the beacon node, which is the result of environmental obstruction. RSS based localisation systems suffer from obstacles and walls in indoor places, which weaken the SS values in most cases. Thus, RSS based localisation systems offer low-localisation accuracy in indoor environments, as signals can be affected by walls and obstacles.

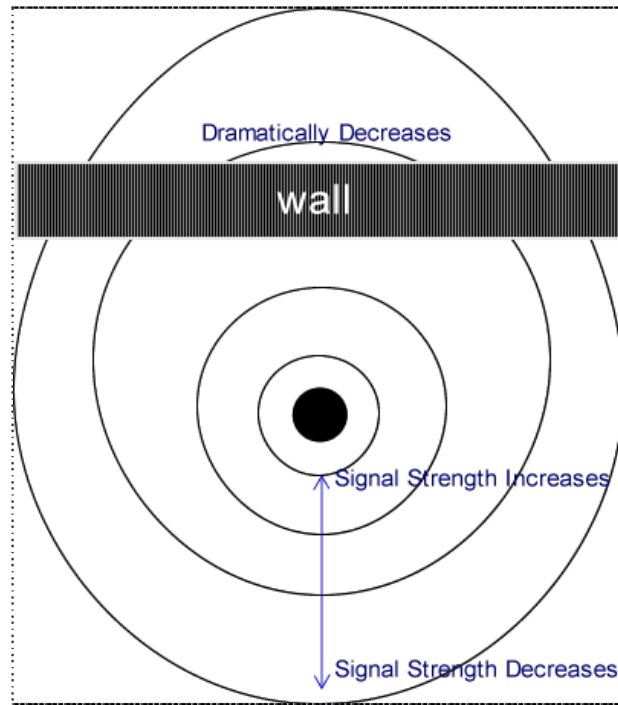

Figure 3-2: Signal strength pattern with obstacles

The proposed approach computes the environmental factors between beacon nodes with known positions, based on finding out the relationship between distances and RSS values. The proposed tracking system consists of three main phases, as shown in Figure 3-3.

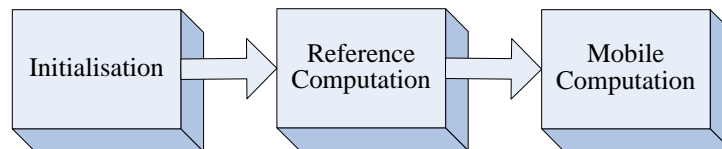

Figure 3-3: Localisation phases

3.2.3.1 Initialisation Phase

The mobile target sends “Hello” messages to all beacon nodes in its area, and awaits responses from them. The beacon nodes in the mobile target’s range send acknowledgements to the mobile target. The mobile target selects at least three stationary beacon nodes, to triangulate its location. If the mobile device receives less than three acknowledgements, it sends the “Hello” message again. This phase is repeated until acknowledgments are received from three different beacon nodes.

3.2.3.2 Beacon Node Computation Phase

In this phase, the environment factors are calculated based on the selected beacon nodes collaborated in the localisation process. The environment factor ef_{ij} can be measured between each beacon node pair b_i and b_j . For instance, if the mobile target is covered by three beacon nodes, there will be three different environment factors between these nodes, as shown in Figure 3-4. The environmental factors are calculated based on the distance between beacon nodes and RSS values. It is important to note that distances between beacon nodes are known and fixed. The environmental factor ef_{ij} is calculated between adjacent beacon node b_i and b_j as follows:

$$ef_{ij} = \frac{rss(b_i, b_j)}{dist(b_i, b_j)} \quad (3-4)$$

The $rss(b_i, b_j)$ represents the SS value between beacon nodes b_i and b_j , and $dist(b_i, b_j)$ refers to the distance between beacon nodes b_i and b_j . The average environmental factor μ_{ef} can be introduced as the main characteristics for the tracking environment. This can be represented by equation (3-5).

$$\mu_{ef} = \frac{\sum_{i=1}^n ef_{ij}}{n} \quad (3-5)$$

where n is the total number of beacon nodes covering the mobile target MT .

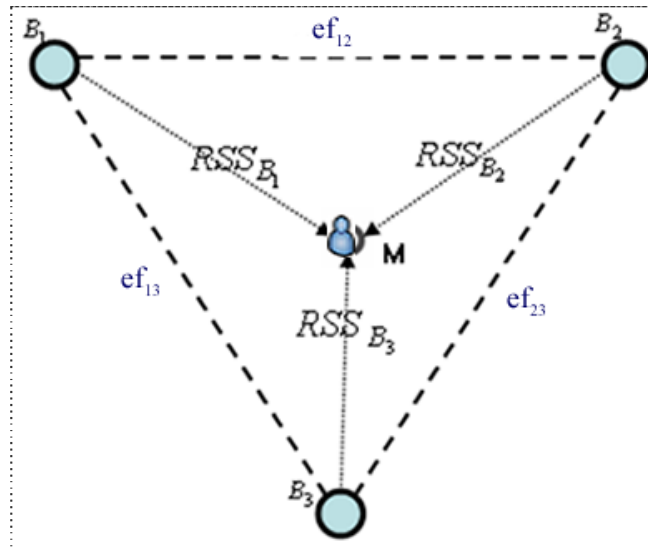

Figure 3-4: Localisation method based on environmental factors

3.2.3.3 Mobile Computation Phase

Each mobile target receives at least three different factors from beacon nodes, in addition to the RSS values for each beacon node. The mobile node can improve the localisation accuracy based on adjusting the received signal values from several beacon nodes.

Calculating the final distance between target node and beacon nodes is executed in the mobile target device. This is due to the mobile target device's larger memory size, faster processor, and longer battery life. The mobile target can be a laptop or PDA device, and therefore can display the current position for the mobile target.

Each mobile target node improves its location accuracy by comparing the RSS values with the received factors. If the mobile target is covered by three beacon nodes, then every SS value received by a mobile target can be adjusted based on two different factors, ef_{ij} and ef_{ij+1} . Two distances will be calculated based on the measured factors; the final distance will be calculated based on averaging both measured distances. This phase is repeated for all of the RSS values. The mobile target can calculate the distance between itself and each beacon node based on the following equation:

$$dist(MT, b_i) = \frac{\left(\frac{rss(MT, b_i)}{ef_{ij}} \right) + \left(\frac{rss(MT, b_i)}{ef_{ij+1 \text{ or } j-1}} \right)}{2} \quad (3-6)$$

where $dist(MT, b_i)$ refers to the distance between mobile target MT and beacon node b_i , $j = \{1,2,3\}$ depends on the number of beacon nodes which are connected to beacon node b_i . In this case, three different distances are measured based on the previous equation, as the mobile target connects to at least three beacon nodes. A triangulation technique is applied in order to find out the final location of the target node MT . The localisation algorithm is summarised in Figure 3-5.

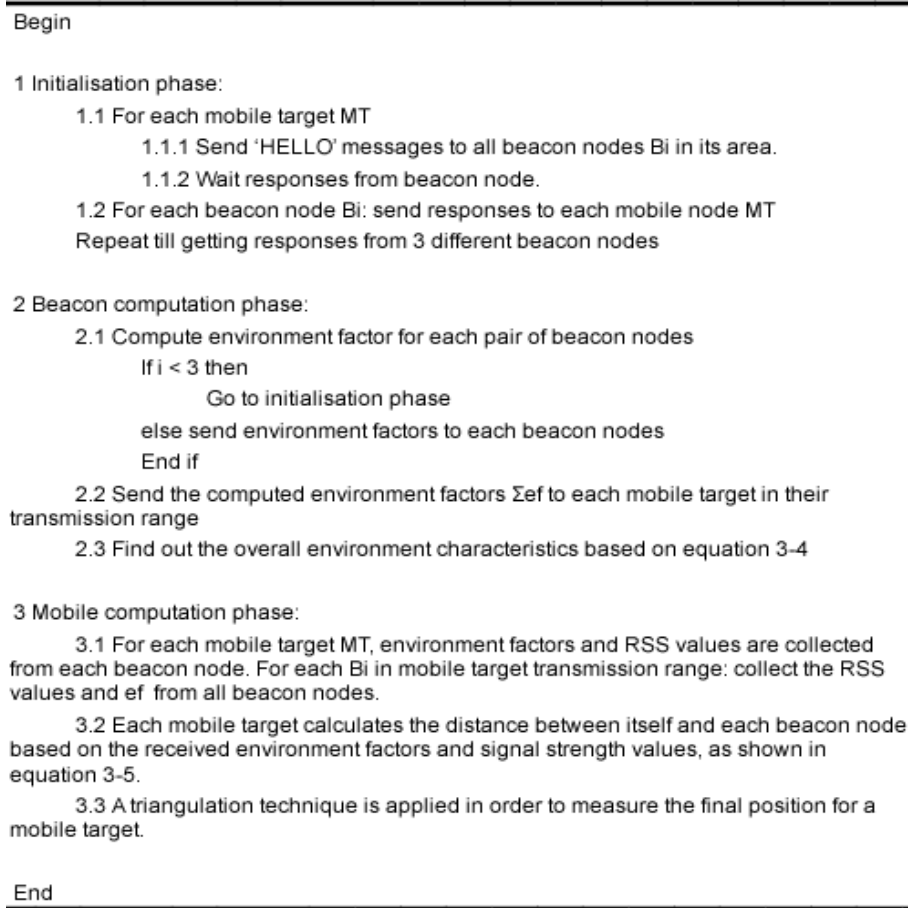

Figure 3-5: Localisation algorithm

3.3 Experiments

The main features of sensor devices which have been used in the experiments are explained in this section. The building's layout is depicted in Figure 3-6, which

shows the positions of the beacon nodes. RSS values were collected from several mobile device positions from three different beacon nodes. Finally, the collected RSS values were improved based on the measured environment factors from several beacon nodes.

3.3.1 Hardware Platform

In the experiments, a JN5139-EK010 sensor node platform was used. This module offers low power-consumption, low processor overhead, and a low cost platform for WSN's. It supports complex tree or mesh network topologies providing reliable coverage over large areas, and is able to measure the RSS value for each packet received. Jennic's ZigBee stack API offers rapid application development by providing simple programming to the standard ZigBee network layer.

3.3.2 Experimental Test-bed

The experimental test-bed consisted of four main sensor nodes. One of them was used as a mobile target, and the rest as beacon nodes with known positions. Two main sensor devices were used in achieved experiments:

1. Coordinator: there was only one coordinator in the network. It was considered as a mobile target in the proposed study. It was responsible for collecting beacon packets from several stationary sensor nodes in addition to collecting the environment factors. The received packets were transferred to a laptop connected with the coordinator in order to calculate the position of the mobile target node.
2. Router: there were three router devices with known positions distributed in the tracking area. Routers are considered as beacon nodes, and they send beacon packets to every mobile target in their range. Each router can calculate the environment factor between itself and the other routers in its range. It is generally assumed that the stationary sensor nodes are with known positions within a building layout, and that the layout of this building is known.

The achieved experiments were conducted in the FK research area (41.5×11.3 m) at Loughborough University. Figure 3-6 shows the main structure of FK area. Three beacon devices (router nodes) were deployed in that area, as indicated in

Figure 3-6. This area involved 8 offices and two meeting rooms. The rest contained desks, cabinets, and chairs, which affect the RSS values.

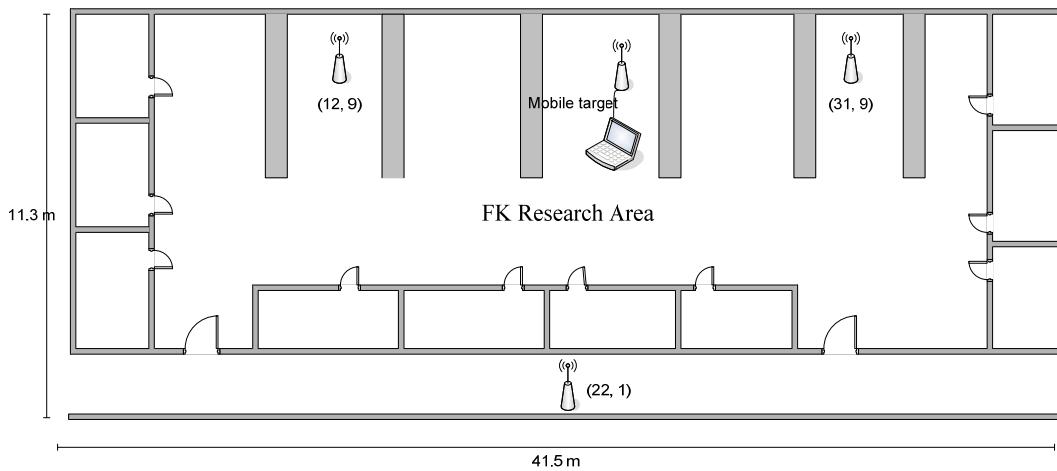

Figure 3-6: FK office test environment

3.3.3 Analysing RSS Measurements

To grasp the relationship between distance and RSS values in an indoor environment, RSS values were gathered from three beacon nodes in FK area. Three beacon nodes were deployed in three different positions as shown in Figure 3-6, and collected the RSS values between each beacon node and the mobile target at several points. The RSS values were collected on the distances 0.5, 1, 2, 4, 8, 12, and 16 m, as seen in Figure 3-7. This process was repeated 8 times, each time being called a ‘treatment’. All of these measurements were performed in the FK research area. 8 measurements were performed for each position, and took the average as the measured LQI value.

To enhance the proposed idea, the experiments were achieved in different equidistant areas, and the environmental factor value was calculated for each area. Through experiments, it was shown that the environmental factor value decreases as distance increases, which supports the proposed approach in this chapter.

It was noticed that the RSS signal values are affected and reduced by obstacles. As shown in Figure 3-7, there are no significant differences among SS values collected for different treatments on several different distances. This indicates that increases the distance will reduce the value of RSS, and therefore, RSS method can be used in tracking systems. Figure 3-8 shows the average RSS values through several distances.

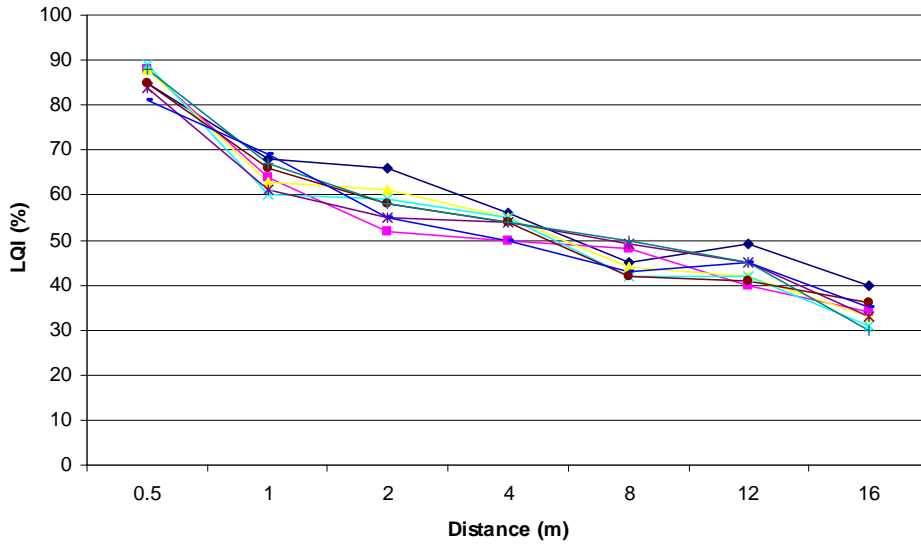

Figure 3-7: Analysing RSS values through different points

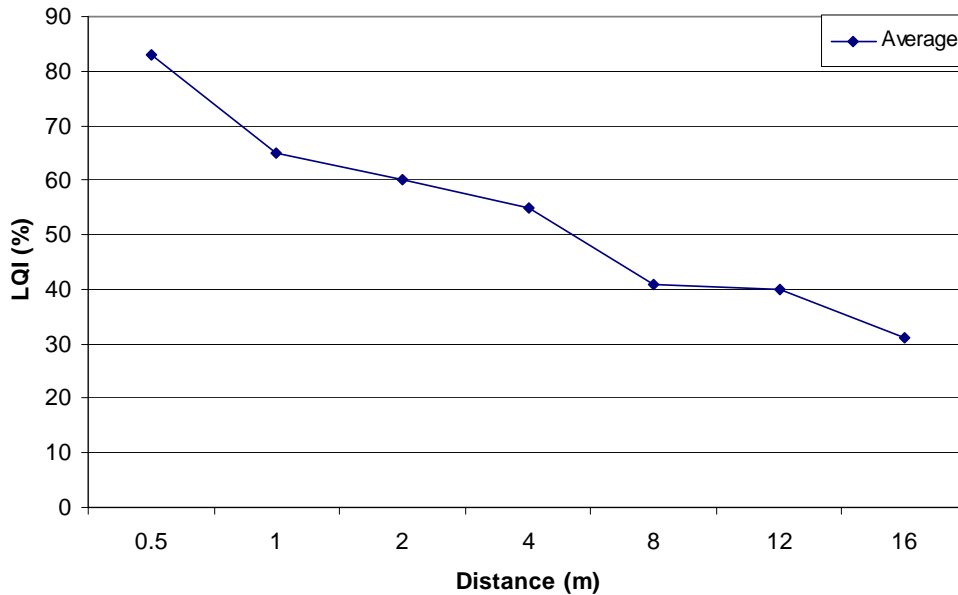

Figure 3-8: Average of RSS values

3.3.4 Adjusting RSS Measurements

RSS values are usually affected by obstacles and walls, hence finding out the location of the target nodes based on SS has some limitations. The RSS values should be analysed and processed in order to get accurate localisation information. In this proposed approach, RSS values are updated based on the computed factors from beacon nodes in the mobile target's area. The proposed method is based on the RSS and the target's distance between each pair of beacon nodes.

The measured received signal values are adjusted by applying the environment factor to each measured received signal value. By this process, it is possible to get RSS values closer to those that would have been attained if the environment characteristics were ideal. This also means that the effect of boundaries is almost eliminated. Based on that, the final distance between each beacon node and mobile target can be calculated using equation (3-5).

To prove the concept, the environmental factor values were measured through different environment obstacles at the same separated distance, as presented in Table 3-1.

Table 3-1: Environment factors through different environmental obstacles

<i>Environment</i>	<i>Distance (m)</i>	<i>Environmental factor</i>
Open	5	16
Soft barreir	5	14
Soft wall	5	11
Concrete wall	5	9

3.4 System Evaluation

In this section, the proposed tracking approach is evaluated by analysing the effect on accuracy and communication costs. The results are compared with those of previous works.

3.4.1 Accuracy

The localisation error E can be found based on the distance difference between actual position $P_i(x_{actual}, y_{actual})$ and approximated position $P_i(x_{new}, y_{new})$ of mobile node i as presented in Equation (3-7). The localisation error through different test points is shown in Figure (3-9).

$$E_i = \sqrt{(x_{actual} - x_{new})^2 + (y_{actual} - y_{new})^2} \quad (3-7)$$

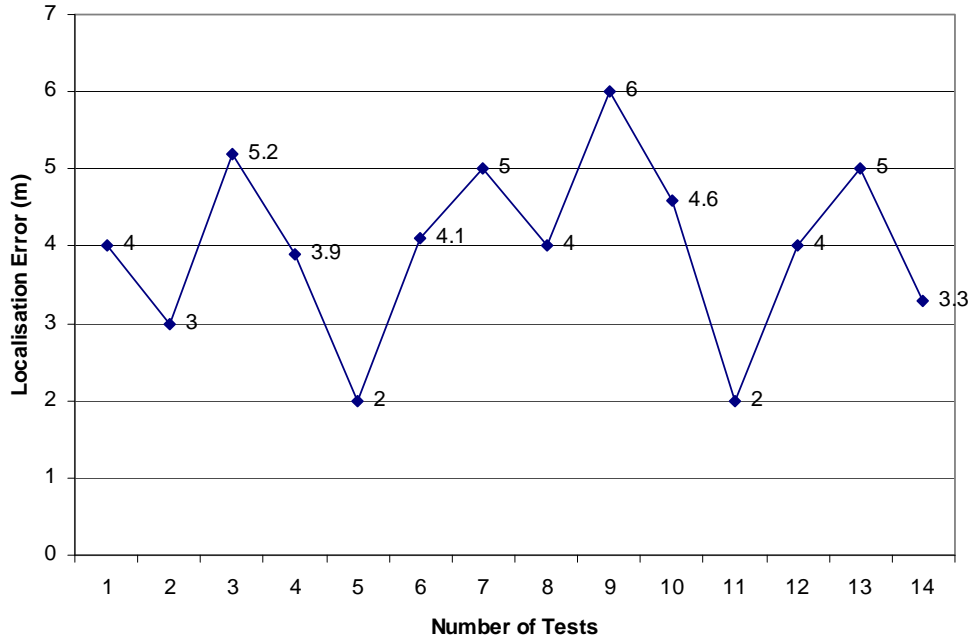

Figure 3-9: Localisation error for the proposed system through several test points

3.4.2 Communication Cost

The communication cost can be calculated based on the number of messages which need to be exchanged among beacon nodes and the mobile target node. There are two main types of messages which need to be exchanged: firstly, the messages which are exchanged between beacon nodes; and secondly, the messages which are exchanged between mobile node and beacon nodes. The average number of messages that are required to be exchanged is noted as l , in order to achieve reasonable localisation accuracy. Every time the mobile target enters a new area, it selects at least three beacon nodes in its range, and then the beacon nodes need to exchange a number of packets between them. Each beacon node sends at least three messages in order to find out the factors between beacon nodes. After that, every two seconds, each beacon node sends two beacon messages to the mobile target in its range. Consequently, the average number of beacon messages l which will be exchanged based on the experiment study is implemented in equation (3-8).

$$l = n \cdot f \quad (3-8)$$

where f is the final time in seconds, and n refers to the total number of beacon nodes. l is measured based on the number of beacon nodes n , which send two messages every two seconds to the mobile target. The beacon node should

revert to sleep mode when the mobile target leaves the area. The overall cost is calculated based on the total number of messages over a tracking period of time.

The coordinator, which is considered a mobile target, is connected to a laptop which calculates and measures the position for each target node. This laptop will be replaced by a PDA in future.

3.5 Discussion

In this section, test the localisation accuracy for two systems (the proposed system in this chapter, and the normal triangulation model) are evaluated. Two experiments were conducted in the same area, and under the same conditions to determine any variables affecting the results. The first step involves deploying the normal RSS model; readings were collected from fourteen different points.

In the second step, readings were collected from the same points but using the proposed localisation approach in this chapter. Figure 3-10 shows the difference between these two models. As shown in the same figure, the accuracy was improved by deploying the proposed localisation function for the collected RSS values. This may give an indication about the effect of environment characteristics on measuring the distance between mobile devices and beacon nodes. Apparently, localisation information is more correct and reliable when measured using the RSS based model proposed in this chapter than the conventional RSS model.

Several RSS based localisation systems have been proposed recently which offer good positioning accuracy. However, some of them suffer from requiring a specific spherical radio propagation assumption, and others can only be deployed in outdoor environments. This is clear in the systems proposed by Bulusu et al. (2000) and Blumenthal et al. (2007), in which highly accurate localisation information is obtained in outdoor environments, but their system cannot work efficiently in noisy environments. Similarly, the models of Blumenthal et al. (2005) and Reichenbach et al. (2006) involve localisation methods which assume that the transmission range is represented by a circle, which can only be applied outdoors.

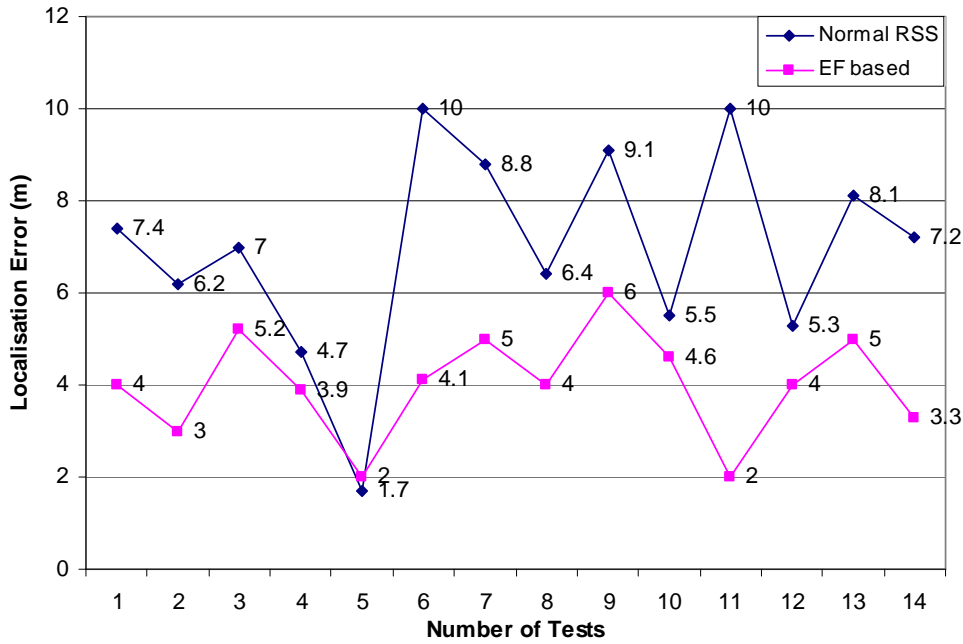

Figure 3-10: Proposed approach versus an existing RSS triangulation

The implementation of previous studies was limited in scale, as in the system proposed by Reichenbach and Timmermann (2006), in which the experiments were conducted in a small area (300×300 cm). The proposed work in this chapter was implemented in a realistic environment (41.5×11.3 m). The proposed RSS-localisation approach is different from previous works, as it is based only on the RF values and the distances between beacon nodes. The environment's characteristics were taken into consideration in order to improve the localisation accuracy.

3.6 Summary

In this chapter, the RF based localisation approaches were explored. RSS techniques have been deployed in several localisation and tracking systems due to low cost and ease of deployment.

The proposed system is RSS based and takes range measurement inaccuracies into account. The implemented localisation method is based on the distance between beacon nodes and the RSS values of them, offering lower communication overhead and localisation complexity. The localisation accuracy has been improved based on computing environmental factors between beacon nodes. The proposed environmental factor function can eliminate the effect of the environment's

characteristics, and consequently help in more accurately estimating the position of the mobile target nodes.

The performance evaluation in terms of localisation accuracy and communication cost was conducted based on real experiments. Comparison between the proposed approach and the normal RSS based approach was accomplished under the same conditions.

The localisation error range of the proposed approach is 2 to 6 m, therefore, the proposed approach works well in tracking applications where high localisation accuracy is not required. In addition, RSS based localisation systems do not require additional hardware to be attached to each sensor device.

CHAPTER 4

A FINGERPRINTING BASED LOCALISATION APPROACH

4.1 Background and Motivation

The previous chapter proposed a triangulation approach based on RSS technique. The complexity of applying a triangulation approach arises from the need to accurately obtain the distance measurements from the RSS as indoor radio signal propagation is very complicated because of signal attenuation due to distance, the effect of multipath propagation, and penetration losses through obstacles.

A fingerprinting based localisation approach is presented in this chapter in order to reduce the localisation error achieved in the triangulation based approaches. Location fingerprinting methods are the most promising solution due to their low cost and high accuracy in terms of localisation. However, fingerprinting methods require the collection of a large number of reference points in the tracking area to achieve reasonable localisation accuracy.

There are two main challenges to designing and developing a fingerprinting system. Firstly, there is the problem of collecting the RSS samples and storing them in the DB, as this process requires a long period of time when the localisation system is deployed in a large area. Secondly, the searching procedure through the

stored samples to compute the location is difficult. Fingerprinting based approaches have been researched and addressed in several works (Li et al. 2006), (Small et al. 2000), (Bahl et al. 2000), and (Shareef et al. 2008), but most of the existing approaches have suffered from the requirement to collect a high number of reference points during the offline phase.

In this chapter, a fingerprinting based localisation approach is proposed, which aims to reduce the total number of reference points that need to be collected in the offline phase while achieving low localisation error of between 1 and 3.5 m. Moreover, the proposed system assigns a unique feature to each small area in order to reduce the time needed to carry out the searching procedure.

4.2 Fingerprinting based approach

The indoor fingerprinting positioning approach developed in this chapter includes three main phases: the Creation of the Fingerprint Table phase, the Feature Identification phase, and the Estimation phase. The first two phases are carried out during the offline stage while the third one is carried out in the online phase. Figure 4-1 depicts the proposed approach and Table 4-1 includes the definitions of several parameters.

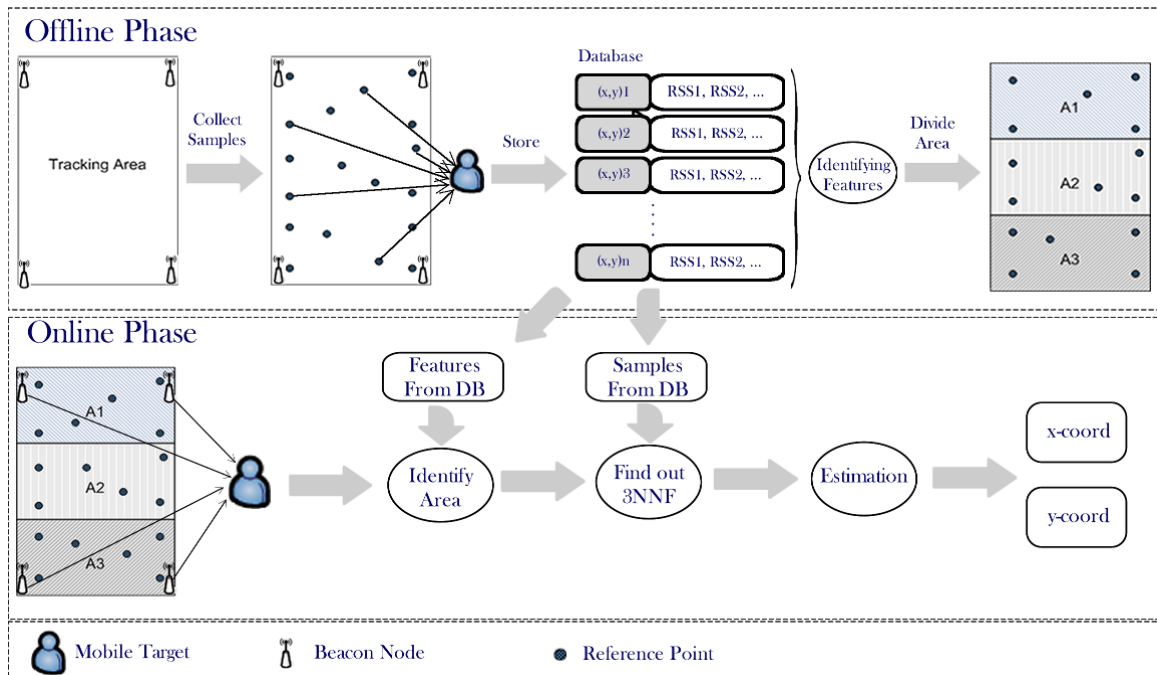

Figure 4-1: Fingerprinting based approach

Table 4-1: Definitions of parameters

<i>Name</i>	<i>Parameter</i>	<i>Definition</i>
Reference point	r	A point with known RSS values collected from the beacon nodes, and known (x, y) coordinates
Estimated point	e	A point which needs to be computed based on the RSS values collected from beacon nodes
Criteria	C_{A_c}	A set of features distinguishing sub-area A_c from other sub-areas

4.2.1 Creation of the Fingerprint Table Phase

Assume that the tracking area is divided into grid points, and the coordinate for each grid point is $P_i = (x_i, y_i)$, $i=1, 2, \dots, n$ where n is the total number of grid points. Also m is the total number of reference points, where $m < n$. This phase consists of two stages:

1. Collect RSS values from several beacon nodes $\{b_1, b_2, \dots, b_z\}$ at each reference point r_k and store them in a DB, where z is the total number of beacon nodes, and $k=1, 2, \dots, m$. The collected reference points have to be spread as evenly as possible in the tracking area.
2. Divide the tracking area into sub-areas, based on the collected RSS values.

In the first stage, the mobile target MT goes through a total number of reference grid points m . The mobile target MT starts to receive messages from beacon nodes at each reference point $r_k = (x_k, y_k)$. Let $rss_{b_j}^k$ denotes to the average RSS values from the b_j th beacon node (where $j=1, 2, \dots, z$) at r_k reference point. An RSS vector can be established at each reference grid point as $S_k = \{rss_{b_1}^k, rss_{b_2}^k, rss_{b_3}^k, \dots, rss_{b_z}^k\}$.

The second stage includes dividing the whole tracking area into sub-areas based on assigning a unique feature to each sub-area. There are three reasons behind dividing the tracking area into sub-areas. Firstly, it enhances the localisation accuracy by ranging the RSS values at each sub-area. Secondly, any changes in the environment after the collection phase can be recovered by recollecting reference points from that sub-area. Thirdly, the division of the search area into smaller sub-areas drastically reduces the search space. Based on the previous location of a

mobile target, only the last known sub-area and the immediately surrounding sub-areas need to be searched to find the mobile targets new location.

A labelled training set (including input signals, corresponding output locations, sub-areas and features) is stored in the DB, as shown in Table 4-2.

Table 4-2: Structure of Database

<i>Vector</i>	<i>RSS values</i>	<i>Corresponding sub-area</i>	<i>Feature</i>	<i>Location</i>
S_1	$\left\{ r_{b_1}^{1}, r_{b_2}^{1}, r_{b_3}^{1}, \dots, r_{b_z}^{1} \right\}$	A_1	C_{A_1}	x_1, y_1
S_2	$\left\{ r_{b_1}^{2}, r_{b_2}^{2}, r_{b_3}^{2}, \dots, r_{b_z}^{2} \right\}$	A_2	C_{A_2}	x_2, y_2
\vdots	\vdots	\vdots	\vdots	\vdots
S_n	$\left\{ r_{b_1}^n, r_{b_2}^n, r_{b_3}^n, \dots, r_{b_z}^n \right\}$	A_l	C_{A_l}	x_n, y_n

4.2.2 Feature Identification Phase

In this phase, a unique feature is identified for each single sub-area. The features can be identified based on the RSS values collected from beacon nodes $\{b_1, b_2, \dots, b_z\}$ at the reference points in the sub-area A_c , where $c=1, 2, \dots, l$, and l is the total number of sub-areas.

Assume that the set B represents the beacon nodes in the tracking area, such that $B = \{b_1, b_2, \dots, b_z\}$, and C_{A_c} is a set of categories for the sub-area A_c such that $C_{A_c} = \{Ra_{b_1}^1, Ra_{b_2}^2, \dots, Ra_{b_z}^y\}$, where $Ra_{b_j}^i$ is the range of the RSS values for beacon node b_j , where $i=1, 2, \dots, y$, and y is the total number of ranges for the sub-area A_c , $r_{ss_{A_c}}$ function is defined as follows:

$$r_{ss_{A_c}} : R \rightarrow C_{A_c} \tag{4-1}$$

where R represents the set of reference points.

However, there are N different sub-areas and consequently there are N different feature functions.

For instance, assume that $R = \{r_1, r_2, \dots, r_s\}$ represents reference points in a given sub-area A_c . There is a set of features C_{A_c} that distinguishes the sub-area A_c from other sub-areas, where $C_{A_c} = \{Ra_{b_1}^1, Ra_{b_2}^2, \dots, Ra_{b_z}^z\}$, and Ra_{b_j} is the range of RSS values between a beacon node b_j and all the reference points R in a sub-area A_c . For example, $Ra_{b_i} \in (62, 75)$.

4.2.3 Estimation Phase

In this phase, the mobile target's position is estimated. This phase includes two main stages:

1. Identify the sub-area A_c where the mobile target is in, based on the identified features assigned to each sub-area.
2. Find out the nearest three reference points to the estimated point e in the identified sub-area A_c based on the difference in the RSS readings in the selected area.

In the first stage, to locate the position of a mobile target, the RSS value is recorded between the mobile target MT and beacon nodes $\{b_1, b_2, \dots, b_z\}$ in the mobile target's communication range. The RSS values obtained for MT are compared with the RSS values for known positions. The sub-area with the closest RSS values is assumed to be where MT is located.

In the second stage, to be more precise, to locate the mobile target in the sub-area, the RSS values of the mobile node are compared with the features of the beacon nodes within the sub-area based on finding the difference $diff$ between the RSS values for the estimated point e and for each reference point r in the identified sub-area (computed in the first stage in this phase), as presented in Equation (4-2). The Three Nearest Neighbours based on Feature function (3NNF) proposed in this section, is used to triangulate the mobile target's position. 3NNF includes finding out the 3 nearest neighbours to the estimated point e .

$$diff(S_r, S_e) = \sqrt{\sum_{j=1}^z (rss_{b_j}^r - rss_{b_j}^e)^2} \quad (4-2)$$

where z is the total number of beacon nodes, S_r is the RSS vector at the reference point r , and S_e is the RSS vector at the estimated point e . The algorithm for the proposed system is depicted in Figure 4-2.

Begin

Step (1): *MT* collects RSS values ($rss_{b_1}, rss_{b_2}, \dots, rss_{b_z}$) from beacon nodes (b_1, b_2, \dots, b_z) in the area of interest

Step (2): Find the correct subarea by comparing the collected RSS values ($rss_{b_1}, rss_{b_2}, \dots, rss_{b_z}$) and the unique features $C_{A_i} = \{Ra_{b_1}, Ra_{b_2}, \dots, Ra_{b_z}\}$

Step (3): Calculate the difference in RSS readings between the estimated ($rss_{b_1}^{es}, rss_{b_2}^{es}, \dots, rss_{b_z}^{es}$) and for the reference points in the selected subarea, and store them in RSS vector S_k

Step (4): Sort the RSS vector S_k in descending order

Step (5): Pick up the first r_1 , second r_2 , and third r_3 of the sorted S_k

Step (6): Find out the RSS values for the three reference points r_1, r_2 , and r_3

Step (7): Measure the difference between RSS values for r_1 and the readings for the e

Step (8): Measure the difference between RSS values for r_2 and the readings for the e

Step (9): Measure the difference between RSS values for r_3 and the readings for the e

Step (10): Triangulate the mobile target's position based on the measured differences in Steps (7), (8), and (9)

End

Figure 4-2: Localisation process

4.3 Experiments

In order to evaluate the proposed fingerprinting approach, the proposed approach was implemented on real sensor nodes. In this section, the main features of the proposed system, such as Graphical User Interface (GUI), the mobile and beacon nodes' model, and experimental test-beds, are illustrated.

4.3.1 Graphical User Interface

In order to facilitate the collection and segmentation processes of the tracking area, the map of the area is stored on a laptop and a user interface, based on VB.net, was designed. In this section, the collection process, and the segmentation process are illustrated.

4.3.1.1 Collection Process

In the first phase, the user has to distribute the beacon nodes over the tracking area, and then collect the RSS readings at several reference points. This can be achieved by a single click on the displayed map which selects the reference point on the map and then stores the RSS readings from each beacon node. A total number of 70 and 60 measurement points are identified and collected from distinct physical locations on test-beds 1 and 2 respectively. The proposed approach in this chapter offers low power consumption when reasonable numbers of reference points are collected (70 and 60 measurements). The GUI of the proposed system is shown in Figure 4-3.

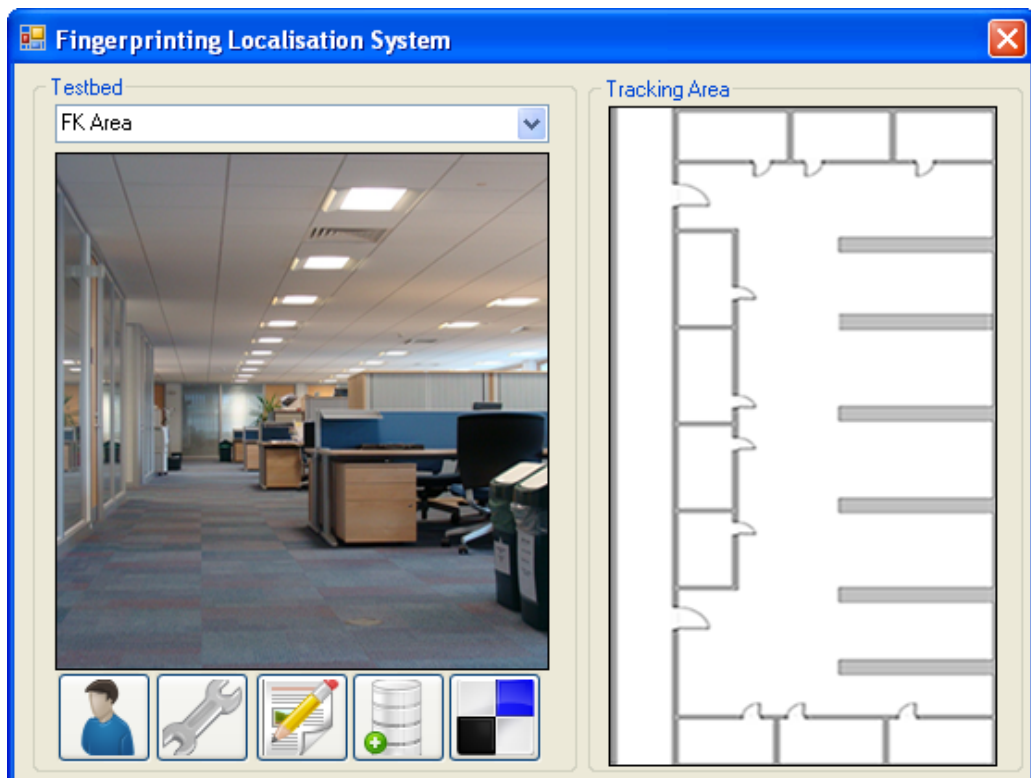

Figure 4-3: GUI for the proposed system

4.3.1.2 Segmentation Process

Dividing the tracking area into sub-areas can be achieved in one of two ways: manual or autonomous. The manual selection can be processed by left-clicking and selecting the desired sub-area on the displayed map. The system is designed to check if there is a common feature among reference points. In the autonomous process, the system divides the area into sub-areas randomly and then checks the RSS values for the reference points in that area. If these reference points have a

common feature, then the system will consider it as a small area, and separate it from the other area. Otherwise, the selected sub-area will be reduced and the previous step is repeated. The autonomous segmentation steps are shown in Figure 4-4.

In the estimation phase, the mobile target collects RSS values from beacon nodes in its area and transfers these values to the sink node; it then displays the final position on the map.

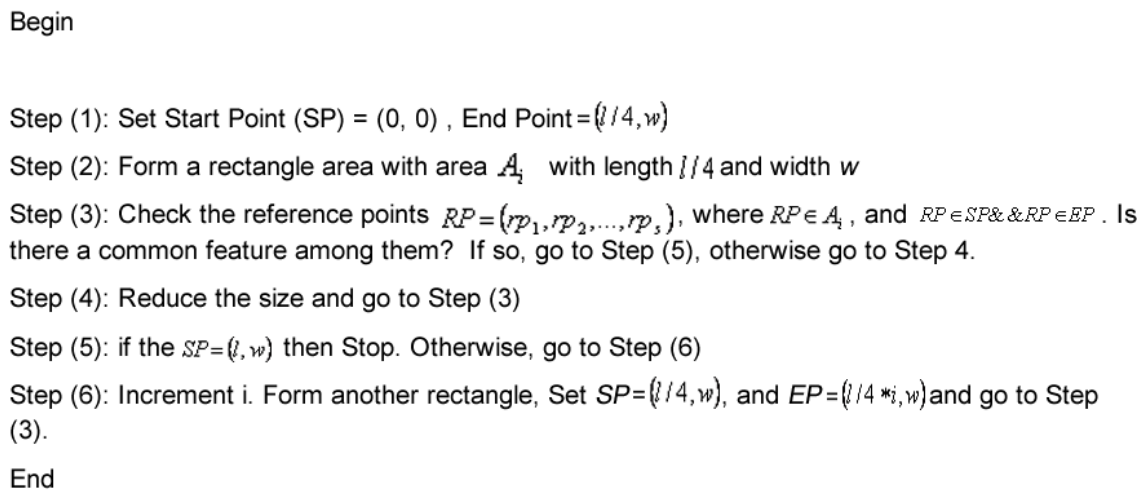

Figure 4-4: Autonomous segmentation process

4.3.2 Mobile and Reference Node Model

Similar to the previous chapter, a JN5139-EK010 sensor node platform was used for both the mobile target and for beacon nodes, in order to test the validity of the proposed fingerprinting approach.

The proposed system was implemented through the ZigBee sensor network. As stated above, ZigBee standard offers 3 main roles: coordinator, router and end-device nodes. In the experiments, the mobile target and beacon nodes were considered as router devices. However, the coordinator was considered as a sink node which is responsible for collecting localised information from the mobile target and transferring it to a PC via a serial cable.

4.3.3 Experimental Test-beds

The proposed approach was evaluated in two different experiment test-beds in order to test its efficiency and accuracy. The experimental test-bed 1 was located in

the 1st floor of the Holywell Park building at Loughborough University. Its layout has dimensions of 41.5 × 11.3 m. As shown in Figure 4-5, test-bed 1 includes obstacles and walls, which affect the localisation accuracy. The experimental test-bed 2, depicted in Figure 4-6, is located in the Sir David Wallace Sports Hall at Loughborough University; it has dimensions of 30.5 × 11.3 m. For both test-beds, the origin of the coordinate system (0,0) was placed at the left bottom corner.

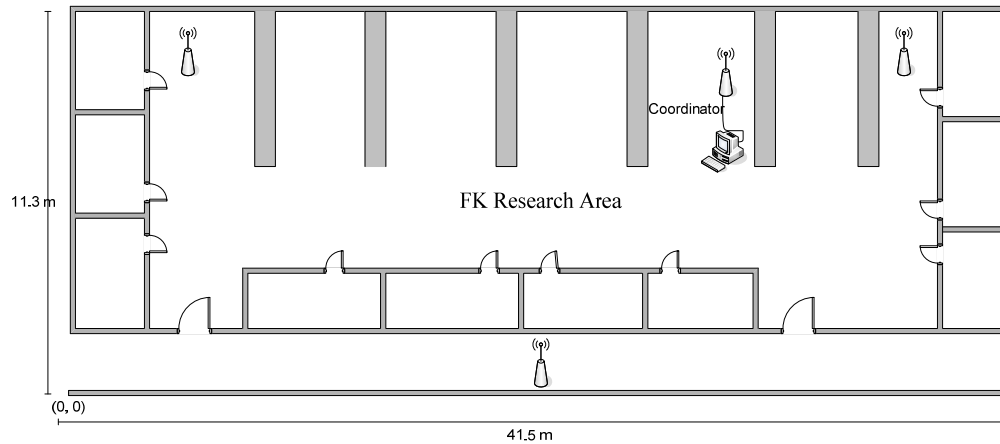

Figure 4-5: Test-bed 1, FK office test environment

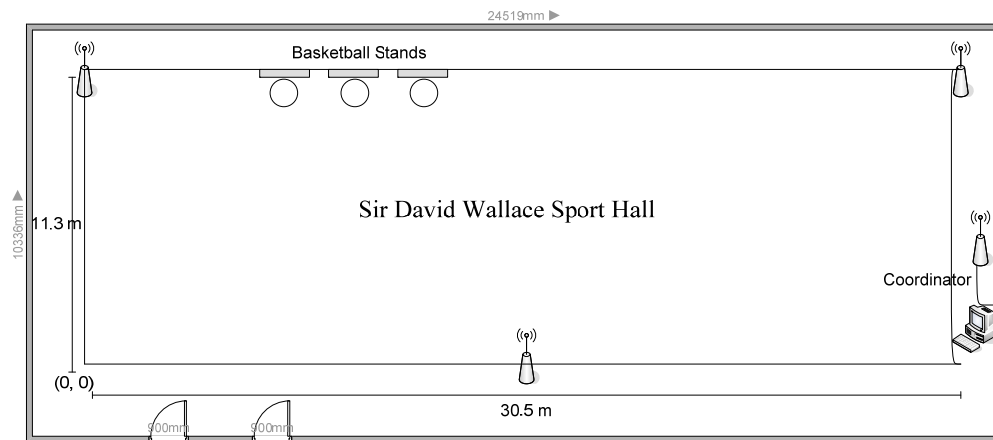

Figure 4-6: Test-bed 2, Sports hall test environment

4.4 Testing Results and Performance Evaluation

To verify the validity of the proposed system described in this chapter, the system was implemented in real experiments conducted in indoor environments using Jennic sensor nodes. The proposed system was evaluated through measuring the localisation error, the effect of the number of reference points collected on the

accuracy of the localisation, and the efficiency of the proposed segmentation methods.

4.4.1 Localisation Accuracy

Localisation error can be described as the distance between the real location and the estimated location. This localisation accuracy is evaluated based on two factors: firstly, the effect of the number of samples collected on the localisation accuracy was evaluated based on two different methods. The localisation error between the approach proposed in this chapter and the RBF NN module was compared.

As stated in Chapter 2, the offline phase in the fingerprinting localisation approaches can be achieved by applying one of two techniques: DB based or NN based. In this section, the efficiency for both techniques is compared. The main benefit of a NN is that prior knowledge of the noise distribution is not required. Noisy distance measurements can be used directly to train the network with actual coordinate positions. According to Shareef et al. (2008), the RBF NN module offers the greatest efficiency in terms of localisation accuracy and memory requirements. As shown in Figure 4-7, the localisation accuracy for the approach proposed in this chapter is better than the RBF NN method as the RBF method needs to be trained at every single grid point; this requires the gathering of a large number of reference points during the offline phase. However, the 3NNF method estimates the mobile target's position based on the unique features assigned to each sub-area, and other RSS readings which are not involved in the identified features are not taken in consideration which might affect the localisation accuracy.

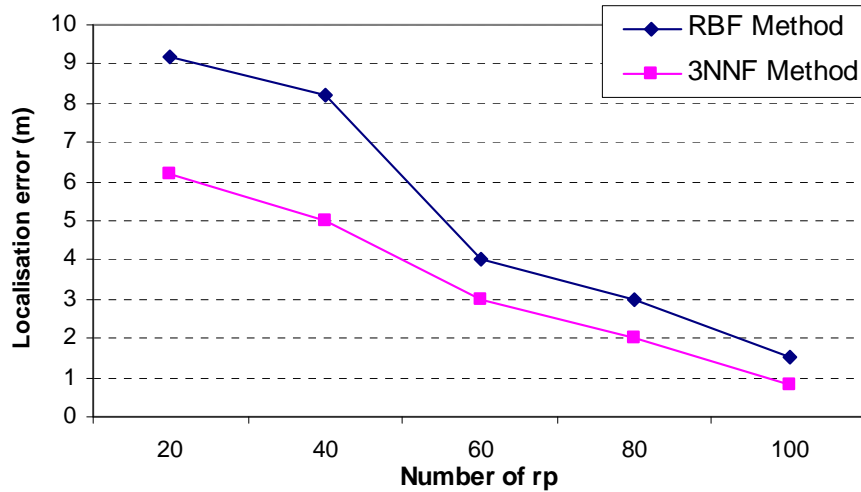

Figure 4-7: Error distance based on the number of reference points

Secondly, the localisation accuracy is evaluated based on the localisation method used in the estimation phase. Figures 4-8 and 4-9 show the localisation error for the proposed fingerprinting localisation approach when RBF NN method was used in test-beds 1 and 2 respectively. The localisation error was between 1.5 and 4 m. However, the localisation error was between 1 and 3.5 m when the 3NNF method was used in the estimation phase for both test-beds (test-bed 1 and 2) as shown in Figures 4-10 and 4-11 respectively. In both figures, the number of reference points (r), test points (t), and estimated points (e) are depicted.

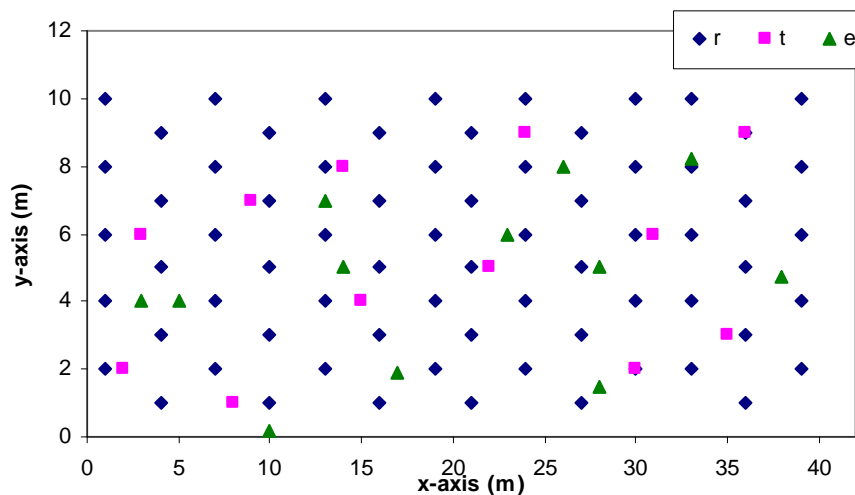

Figure 4-8: Localisation error using RBF method in test-bed 1

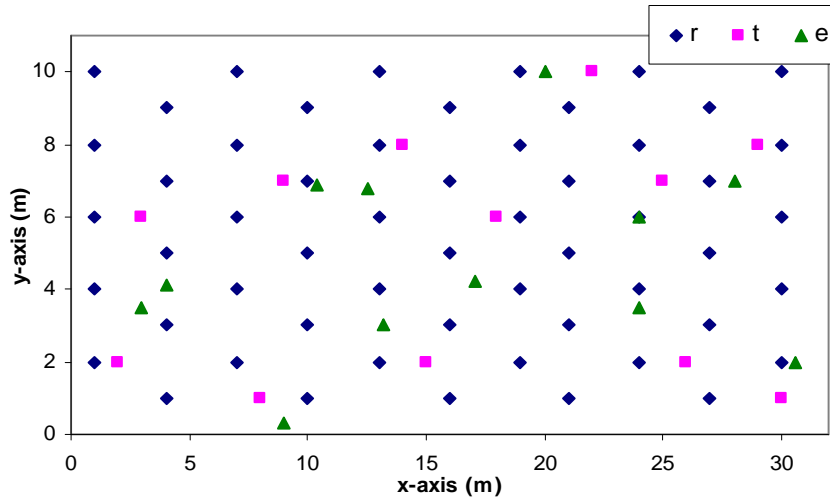

Figure 4-9: Localisation error using RBF method in test-bed 2

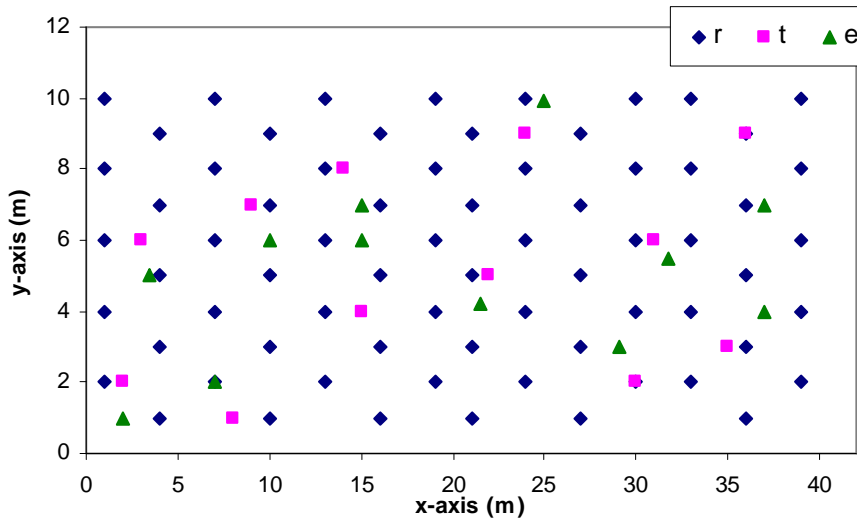

Figure 4-10: Localisation error using 3NNF method in test-bed 1

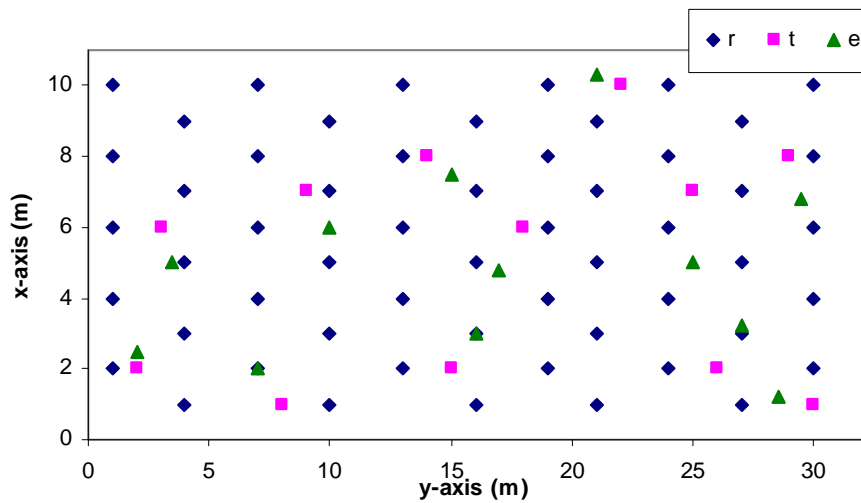

Figure 4-11: Localisation error using 3NNF method in test-bed 2

4.4.2 The Efficiency of the Segmentation Process

Assigning features to the divided area is a critical task in the proposed approach. As previously discussed, the segmentation can be achieved in two ways. In this section, the ability of the proposed system to divide the whole area into sub-areas is evaluated. The system was evaluated using two different test-beds.

The autonomous segmentation process works efficiently in open environments, such as in test-bed 2. Figure 4-12 depicts the RSS values from each beacon node in each sub-area. However, deploying an autonomous process in environments where obstacles and walls are situated is a challenging task as the RSS behaves irregularly in different areas. Thus, it was a challenging task for the autonomous segmentation to achieve the division process. The proposed autonomous process was not able to divide test-bed 1 into sub-areas. A manual segmentation was used instead; Figure 4-13 shows the irregular distribution of RSS values in a complex environment.

Figures 4-12 and 4-13 show how the tracking area is divided into sub-areas based on a unique feature for each one. Tables 4-3 and 4-4 show the assigned features for test-beds 1 and 2 respectively.

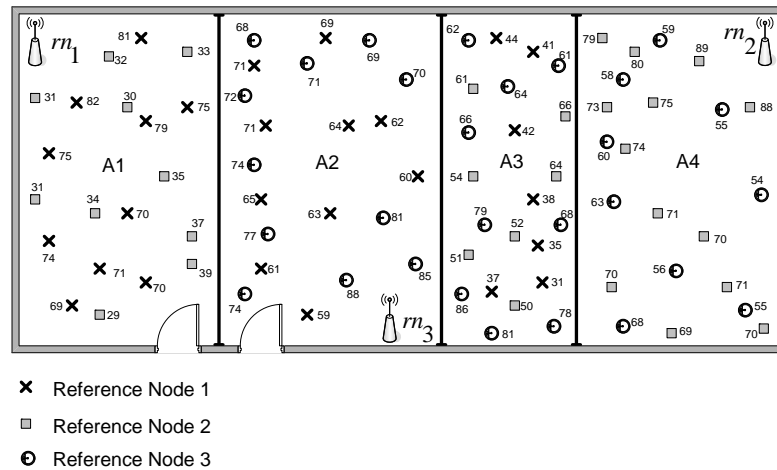

Figure 4-12: Autonomous segmentation process through test-bed 2

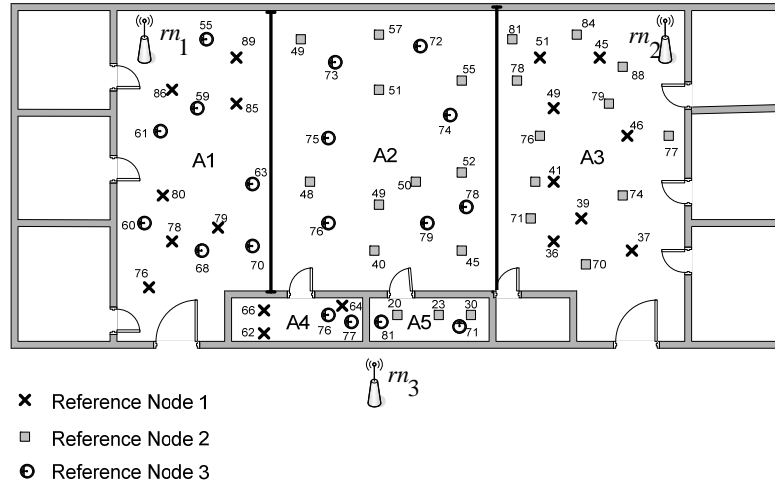

Figure 4-13: Manual segmentation process through test-bed 1

Table 4-3: Assigned categories for test-bed 1

<i>Sub-area</i>	<i>Category</i>	<i>Features</i>
A_1	C_{A_1}	$b_1 \in (70 - 81)$
		$b_2 \in (29 - 39)$
A_2	C_{A_2}	$b_1 \in (59 - 71)$
		$b_3 \in (69 - 88)$
A_3	C_{A_3}	$b_1 \in (31 - 44)$
		$b_2 \in (50 - 66)$
		$b_3 \in (61 - 86)$
A_4	C_{A_4}	$b_2 \in (69 - 89)$
		$b_3 \in (54 - 68)$

Table 4-4: Assigned categories for test-bed 2

<i>Sub-area</i>	<i>Category</i>	<i>Features</i>
A_1	C_{A_1}	$b_1 \in (76-89)$ $b_3 \in (55-70)$
A_2	C_{A_2}	$b_2 \in (40-57)$ $b_3 \in (72-79)$
A_3	C_{A_3}	$b_1 \in (36-51)$ $b_2 \in (70-88)$
A_4	C_{A_4}	$b_1 \in (62-66)$ $b_3 \in (76-79)$
A_5	C_{A_5}	$b_2 \in (20-30)$ $b_3 \in (71-81)$

4.5 Discussion

Fingerprinting for WSN has received little attention recently in tracking applications. The proposed fingerprinting approaches in (Li et al. 2006; Small et al. 2000; Li et al. 2005) offer reasonable localisation accuracy, however, they require collecting a large number of reference points. This procedure introduces two problems: the first one is the problem of collecting fingerprinting samples in terms of cost and labour, and the second is the need to search through the collected samples to determine the target's location.

Obviously, the need for more reference points and measurements indicates that the offline stage is a critical task in terms of time and labour. Different NN modules have been used in several fingerprinting localisation approaches as in (Ahmad et al. 2006; Battit et al. 2002; Shareef et al. 2008) in order to reduce the total number of reference points collected, therefore reducing the time needed to complete the offline phase. Conversely, through experiments, it has been shown that NNs performs well in the area on which it has been trained, and consequently, NNs need to be trained at each grid point in order to offer reasonable localisation accuracy. This procedure adds time and power-consumption to the whole WSN. The approach presented in this chapter does not require the collection of a large number of reference points as it is based on identifying unique features for each sub-area. Consequently, the searching procedure is achieved in a short time period.

An efficient fingerprinting localisation approach was implemented using a WSN by Shareef et al. (2008). The implementation of this approach was limited in scale as it was implemented in a small area (300×300 cm). Conversely, the approach proposed in this chapter was deployed in two huge areas (test-bed 1 and test-bed 2) with sizes of 41.5×11.3 m and 30.5×11.3 m respectively.

A significant localisation system is proposed by Bahl and Padmanabhan (2000), and this proposed system offers good localisation accuracy. However, it is based on the nearest neighbour (nn) method in order to compute the target's coordinates. This includes finding out the two nearest points to the estimated reference point based on the collected RSS values. However, the 3NNF method computes the final location based on the features between the reference points and the estimated point. Figure 4-14 shows the localisation error for both the 2nn and 3NNF methods while Table 4-5 shows a comparison between the previous fingerprinting approaches and the approach proposed in this chapter.

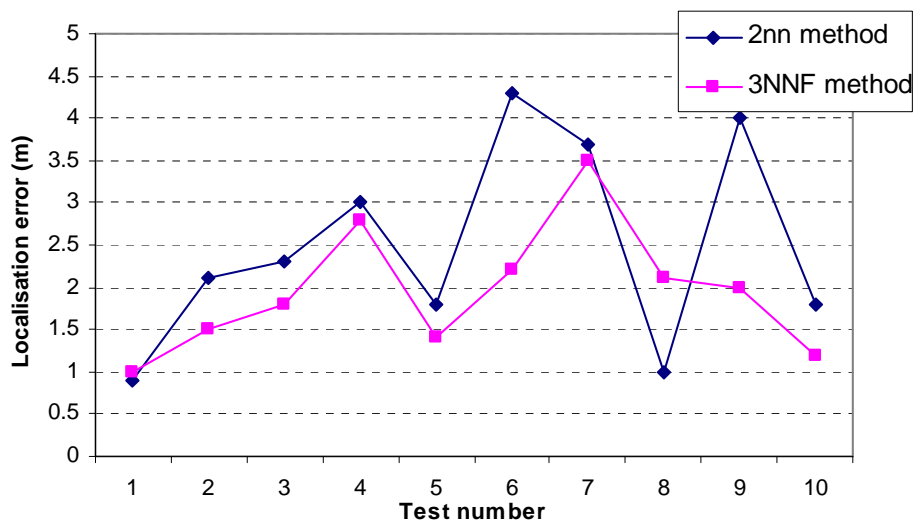

Figure 4-14: Localisation error for two systems

The proposed system includes dividing the whole area into sub-areas based on unique features which uniquely distinguish each sub-area. For most existing fingerprinting systems, any changes to the environments, which alter the collected and stored features at the scenes, require recollecting the predefined data. Conversely, the approach proposed in this chapter does not require reference points to be recollecting from the whole tracking area in the case of changes. It only requires data to be recollecting from the area which has been changed.

Table 4-5: Comparison between fingerprinting approaches

<i>Localisation approach</i>	<i>Area size (m)</i>	<i>Number of reference points</i>	<i>Localisation error (m)</i>
Approach by Li et al. (2006)	NA	132	1 – 4
Approach by Small et al. (2000)	Hall	441	0.5 – 7.8
RADAR approach by Bahl and Padmanabhan (2000)	43.5 × 22.5	70	2 – 3
Approach by Li et al. (2005)	23 × 17.5	> 100	1.78
Approach by Ahmad et al. (2006)	NA	300	0.2 – 2.2
Approach by Battiti et al. (2002)	25.5 × 24.5	200	2 – 3
Approach by Shareef et al. (2008)	300 × 300	121	0.1 – 0.4
RBF Approach	41.5 × 11.3	70	1 – 6
3NNF Approach	41.5 × 11.3	70	1 – 3.5

4.6 Summary

RSS based localisation systems are more competitive in terms of both accuracy and cost compared to other localisation systems. The proposed fingerprinting approach in this chapter offers minimum localisation error (1-3.5 m) compared with the triangulation approach proposed in Chapter 3 (2-6 m). However, fingerprinting methods suffer from the fact that they require a large DB and a long training phase; this increases the size and computational burden of the DB.

The implemented work in this chapter offers three advantages over the existing approaches. Firstly, the total number of reference points that had to be collected during the offline phase was reduced. Secondly, the proposed approach offers good localisation accuracy as it is based on 3NNF localisation method. Thirdly, a problem which might arise when any changes on the tracking area have been made has been overcome by dividing the tracking area into sub-areas.

In this chapter, a segmentation process has been designed and implemented in order to divide a tracking area into small areas. The proposed autonomous method only works well in open environments and cannot be used in noisy ones. Manual segmentation can be used in any environment but it requires additional effort and time, in addition to experience regarding the system and how to divide the tracking area.

CHAPTER 5

A DECENTRALISED TRACKING APPROACH

5.1 Background and Motivation

Two localisation approaches were proposed in the previous chapters with reasonable localisation accuracy. This chapter concentrates on the tracking efficiency in terms of power-consumption. In real time tracking applications, it is important to transmit the final coordinates for each mobile target to a central computer in order to display their current positions there. As previously discussed in Chapter 2, there are two ways of communications between nodes (centralised and decentralised). Tracking several mobile targets issue through hundreds of sensor nodes requires the transmission of the location data from beacon nodes to the central node, which normally results in a series of hops through the network. Each of these hops increases the consumption of the limited energy, and therefore precipitates failures within the network as the energy of the beacon nodes becomes increasingly impaired.

As shown in Chapter 2, several tracking systems have been developed recently. However, most of these tracking systems were developed and implemented to work with small number of sensor nodes. In this chapter, a

decentralised tracking system is proposed to track multiple mobile targets in an energy efficient way.

The system proposed in this chapter aims to reduce the power-consumption for the network when the tracking of multiple mobile targets is required through a large number of sensor nodes. The proposed decentralised approach includes grouping the mobile targets in a given area, and selects a mobile target leader for each group. The mobile target leader is responsible for receiving localisation information from other mobile targets and transmitting this information to the central node. This system is applicable to track several mobile targets synchronously with the minimum communication costs, in applications such as tracking employers in a work area, and tracking patients and doctors in a hospital. Figure 5-1 depicts the tracking of multiple mobile targets problem when deploying a high density of sensor nodes. The proposed system is evaluated through implementation using the NS2 simulator environment.

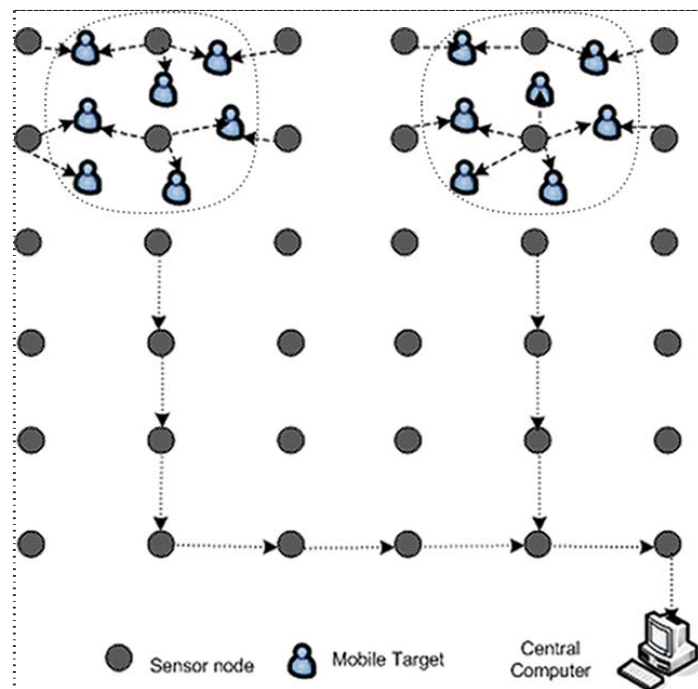

Figure 5-1: Tracking multiple mobile targets problem

5.2 Decentralised Tracking Approach

The proposed system is based on decentralised localisation computation. This means that all the localisation information can be processed on the mobile target device. Only the final coordinates are transmitted to the central node. This reduces

the total number of messages transmitted over the network, and hence reduces the power-consumption for WSN. In this section, the proposed system is illustrated in detail, which aims to track the location of multiple mobile targets with minimum power-consumption. The proposed system consists of 3 main phases, as shown in Figure 5-2.

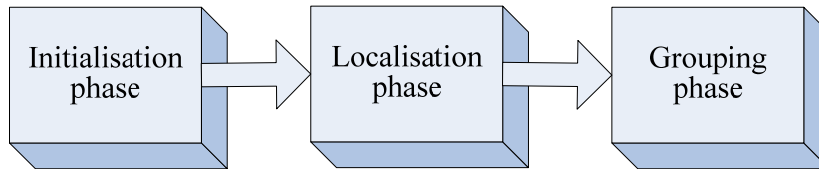

Figure 5-2: Main phases of decentralised tracking system

5.2.1 Initialisation Phase

This phase includes starting the network, and assigning a network address to beacon and mobile nodes. Then, the mobile targets enter the tracking area. Each mobile target checks the beacon nodes in its range, and other mobile targets in its range. Each mobile target subsequently computes the number of hops between itself and the central node.

5.2.2 Localisation Phase

In this phase, each mobile target has to compute its current location based on the collected readings from beacon nodes in its range. The localisation method proposed in Chapter 3 is used to estimate the mobile targets' locations. This process is repeated every 4 seconds to estimate the mobile targets' locations synchronously.

5.2.3 Grouping Phase

A mobile target leader mg has to be chosen in this phase. The main ideas behind choosing a mobile target leader are the following:

1. Reducing the total number of messages transmitted to the central node over the network, and hence the amount of energy consumed during the tracking process is reduced.
2. Managing and organising other mobile targets' locations.

To illustrate this phase, assume $R = \{b_1, b_2, b_3, \dots, b_n\}$ represents the beacon nodes in the area of interest, with the total number n , and

$M = \{MT_1, MT_2, MT_3, \dots, MT_m\}$ represents the mobile targets with the total number m .

Assume that $SM = \{MT_1, MT_2, \dots, MT_z\}$ where z is the total number of mobile targets in a given area, within the same transmission range, and each mobile target MT is covered by at least three beacon nodes to estimate its current location. Each mobile target checks the number of hops between itself and the central node. The mobile target node with the lowest number of hops to the central node is elected to be a mobile leader node. The mobile target leader has to have the following characteristics:

1. It has the minimum number of hops to the central node.
2. It has high energy, above a specific threshold.

The leader mobile target receives the localisation information from other mobile targets in its range, and transmits this information to the central node every 4 seconds. The flow chart for the proposed system is shown in Figure 5-3.

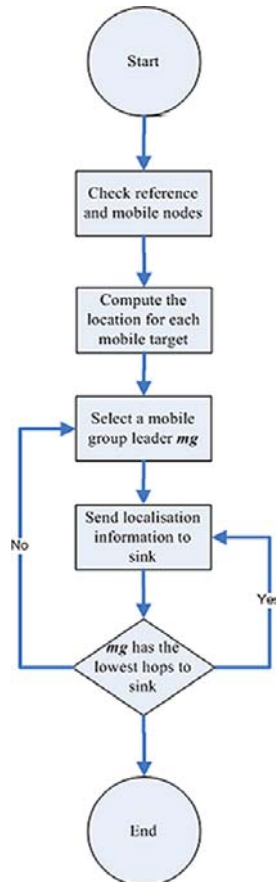

Figure 5-3: Flow chart to implement the improved decentralised approach

5.3 Simulation Setup

In order to evaluate the proposed improved decentralised approach, three different approaches were implemented. Firstly, a centralised localisation approach was considered, which included transmitting the localisation information from each beacon node covering the mobile target to a central node. Secondly, a decentralised tracking system required that each target node estimates its current position and transmits it to the central node. Thirdly, an improved decentralised approach, which included grouping the mobile targets which set in the same transmission range, and then selecting a leader node closer to the central node in order to transmit the localisation information to the central node. Figure 5-4 shows the proposed algorithm for the proposed work.

```

Begin

1 Initialisation phase:
  1.1 For each mobile target MT
    1.1.1 Send 'HELLO' messages to all beacon and mobile target nodes in its
    area
    1.1.2 Await responses from beacon and mobile target nodes
    1.1.3 Compute the number of hops between itself and the sink node
  1.2 For each beacon node rn: send responses to each mobile target mt

2 Localisation phase:
  2.1 For each mobile target MT
    2.1.1 Find out its current position based on the readings collected from
    beacon nodes

3 Grouping phase:
  3.1 A mobile target is chosen to work as a leader node based on the number of hops
  between the mobile target and the sink node
  3.2 The leader mobile target collects the localisation information from the sub-mobile
  nodes
  3.3 The leader mobile target transmits the collected localisation information to the
  sink node
  Repeat 3.1 every 8 seconds
  Repeat 3.2 every 4 seconds

End

```

Figure 5-4: An improved decentralised algorithm

There are two different types of devices in the test-bed: firstly, the beacon node. This includes the stationary sensor nodes with known positions distributed over the tracking area. Secondly, the mobile target node, which represents the

mobile target nodes which need to be tracked. The mobile target is considered as a PDA in the experiments in order to be able to calculate its current position and transmit it to a central node. However, the beacon node is considered as a sensor device which has some limited computation and communication capabilities. Table 5-1 presents some simulation parameters used in the simulation experiments.

Table 5-1: Simulation parameters

<i>Parameter name</i>	<i>Parameter value</i>
Packet size	127 bytes
InitEng	27.00 mA.h
rxPower	49.00 mA
txPower	44.00 mA
Simulation time	360 seconds
Number of nodes	56
Number of mobile targets	20
Average hops	5
Radio model	TwoRayGround
Antenna type	OmniAntenna
Grid size	75 x 65 m ²
Routing protocol	AODV
Mac protocol	MAC/802.15.4

The experiment test-bed consists of 56 sensor nodes and one central node placed on the right corner for the tracking area, as depicted in Figure 5-5. It was assumed that the mobile targets are distributed into 2 groups, and the mobile targets in each group set in the same transmission range.

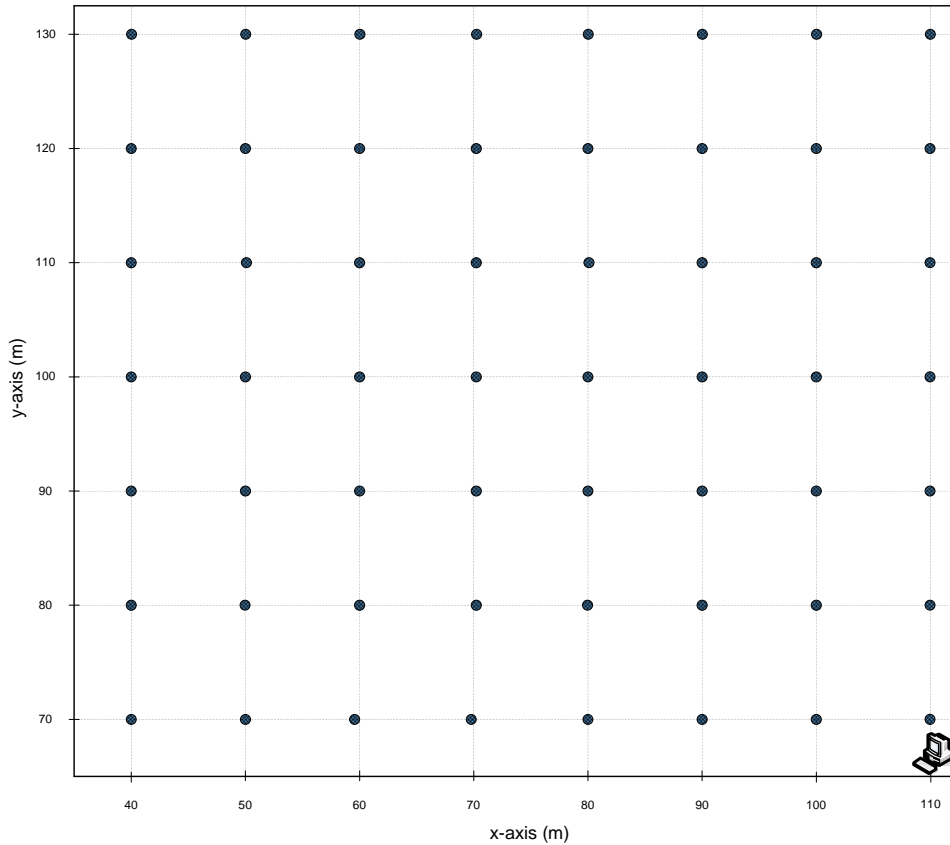

Figure 5-5: Experimental test-bed

5.4 System Evaluation

In this section, three scenarios are examined (centralised, decentralised, and an improved decentralised approaches). Two performance metrics are evaluated: Firstly, total number of messages transmitted over the network; and secondly, the power-consumption for the WSN.

5.4.1 Communication Costs

One of the critical issues in developing a tracking system for sensor nodes is the issue of battery life. Sensor devices are designed to work for periods of from a few months to many years. The proposed approach aims to minimise the total number of messages transmitted over the network in order to reduce the amount of energy consumed. In this section, the total number of messages transmitted to the central node for the three scenarios was evaluated.

In the centralised localisation approach, the localisation messages must be transmitted to a central computer. The total number of messages nm_{loc} transmitted over the network is represented by Equation (5-1).

$$nm_{loc} = 3 \cdot m \cdot \frac{ft}{4} \quad (5-1)$$

where ft , and m refers to the total time of the experiment, and the number of mobile targets set in one transmission range respectively.

However, in the basic decentralised approach, two types of messages are transmitted over the network. Firstly, the messages nm_{loc} transmitted between beacon and mobile target nodes; this is represented in Equation (5-1). Secondly, the messages nm_{cen} transmitted between mobile targets and central node, as presented in Equation (5-2).

$$nm_{cen} = m \cdot \frac{ft}{4} \quad (5-2)$$

The improved decentralised approach deals with three types of messages transmitted over the network, as follows:

1. Local messages nm_{loc} : representing the total number of messages exchanged between each mobile target and beacon nodes, shown in Equation (5-1). These messages are not required to reach the central node (sink node).
2. Mobile messages nm_{mob} : representing the total number of messages transmitted between the mobile target leader and other mobile targets in its range. This type of messages does not affect the energy for stationary sensor nodes, as the communications are between the mobile targets. This is represented by Equation (5-3).

$$nm_{mob} = (m - 1) \cdot \frac{ft}{4} \quad (5-3)$$

3. Global messages nm_{glb} : representing the total number of messages transmitted between the mobile target leader and the central node. This is represented by Equation (5-4). The leader node can send 5 mobile targets' positions in every single packet.

$$nm_{\text{glb}} = \frac{m}{5} \cdot \frac{ft}{4} \quad (5-4)$$

The improved decentralised approach does not require a high number of messages to be exchanged between mobile target node and beacon nodes, even when a large number of mobile targets is required to be tracked. The calculations are processed in the mobile target node, with no need for centralised computations. Figure 5-6 shows a comparison of the messages required to be transmitted among three scenarios. The centralised approach requires transmitting a high number of messages between beacon nodes and central node. However, decentralised approach requires fewer messages to be transmitted when the total number of mobile targets is not large. The improved decentralised approach achieves the lowest number of messages required to be transmitted over the network when the density of mobile target nodes is high.

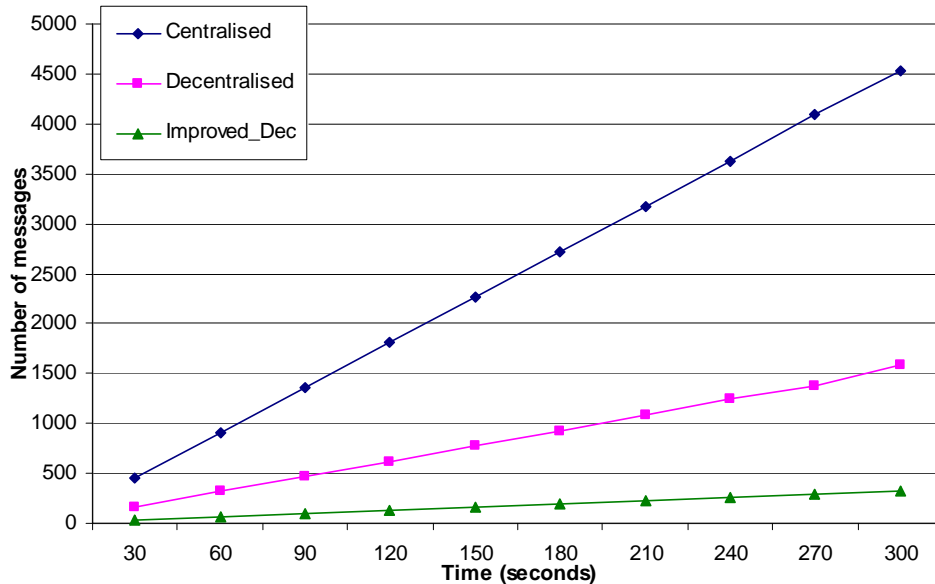

Figure 5-6: Total number of messages for the three systems

5.4.2 Power-consumption

In this section, the power-consumption of each approach is evaluated. Firstly, the power-consumption in the centralised approach P_{cen} is presented in Equation (5-6). Secondly, the power-consumption in the decentralised approach P_{dc} is presented in Equation (5-7). Thirdly, the power-consumption in the improved decentralised approach P_{im} is presented in Equation (5-8).

$$P(nm) = (nm \cdot P_{tx}) + (nm \cdot P_{rx}) \quad (5-5)$$

$$P_{cen} = P(nm_{loc}) \cdot h \quad (5-6)$$

$$P_{dc} = P(nm_{loc}) + (P(nm_{cen}) \cdot h) \quad (5-7)$$

$$P_{im} = P(nm_{mob}) + (P(nm_{glb}) \cdot h) \quad (5-8)$$

where $P(nm)$, P_{tx} , P_{rx} and h are the powers required to transmit a total number of messages nm , transmission power, reception power, and number of hops respectively.

Figure 5-7 compares the battery life of the three approaches (centralised, decentralised, and improved decentralised). As shown, the improved decentralised method achieves longer battery life than both the centralised and decentralised approaches, as it requires a lower number of messages to be exchanged between nodes, and therefore reduces the power-consumption of the whole network.

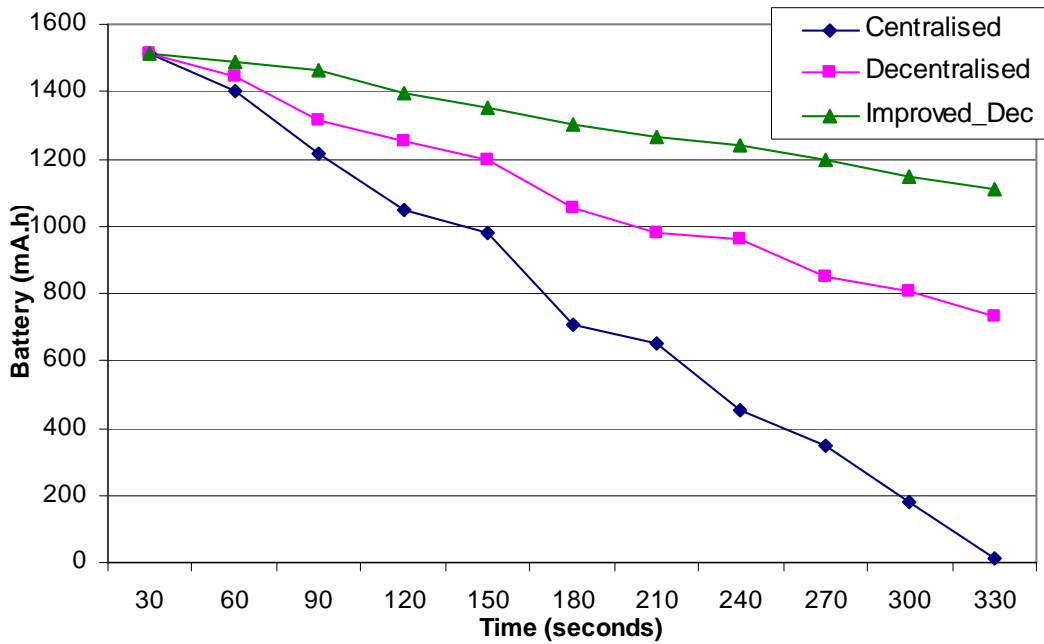

Figure 5-7: Evaluating the power consumption for the three approaches

5.5 Discussion

Centralised based localisation approaches are much more power consuming than distributed approaches. Distributed tracking solutions are more attractive for large sensor networks including thousands of nodes. However, decentralised approaches require transmitting a high number of messages when the density of mobile targets is high. An improved decentralised approach is proposed in this chapter in order to reduce the total number of messages transmitted over the network and hence decrease the power-consumption.

Centralised tracking systems offer efficient communication cost when deployed with a small number of sensor nodes. The centralised systems proposed in (Alippi and Vanini, 2006; Sugano et al. 2006; Doherty et al. 2001) require transmitting the following details to the central node: sensor ID, target ID, packet number and sensor-to-target distance. However, deploying these systems with a high density of sensor nodes requires high power-consumption, as each localisation message must be transmitted via a multi-hop network to a central node.

There is no need to send the localisation information to a central node in a decentralised system, as all the calculations are processed in the mobile target device. The proposed decentralised systems proposed in (Lazos et al. 2005; Shang et al. 2003; Bulusu et al. 2002; He et al. 2003) are efficient for tracking and

localising in large sensor networks. However, these systems are impractical to track a large number of mobile targets as they require a high number of messages to be transmitted between mobile targets and the central computer.

The improved decentralised approach achieves lower power-consumption than both centralised and decentralised approaches. The mobile target leader manages to receive localisation information from other mobile targets and transmits this information to the central computer.

5.6 Summary

In this chapter, an improved decentralised tracking approach is proposed to track the location of multiple mobile targets with minimum communication cost among sensor nodes. The proposed approach achieves an efficient tracking system in terms of localisation and power-consumption by grouping the mobile targets which are set in the same transmission range.

The proposed system aims to increase the lifetime of beacon nodes by reducing the total amount of messages transmitted over the network. The proposed system in this chapter requires attaching a laptop or PDA to each mobile target, in order to process all the communication on the mobile target device. However, it reduces the total number of messages transmitted to the central node, and consequently reduces the total amount of energy consumed in the tracking process. The performance evaluation in terms of communication cost and power-consumption was conducted using NS2 simulator.

CHAPTER 6

TRACKING THROUGH ZIGBEE NETWORK

6.1 Background and Motivation

Two localisation methods have been proposed in Chapters 3 and 4. The methods proposed include tracking a single mobile target, and do not support tracking multiple mobile targets. This chapter focuses on the tracking multiple mobile targets through ZigBee network standard. The existing ZigBee based localisation approaches require deploying the proposed system with coordinator and router nodes. Tracking through the ZigBee network standard is a challenging task when the density of router and end-device nodes is low. However, tracking using full roles of ZigBee standard offers a power efficient solution, as end-device nodes can go to sleep mode, while router nodes have to be activated all the time.

Localisation methods based on RSS require a minimum of three reference nodes to triangulate a mobile target's position. Consequently, due to the previously discussed characteristics of end-devices in Chapter 1, where each end-device can only communicate with one parent node, there may not be three reference nodes available for triangulation of the mobile target node. In a ZigBee WSN this can be caused by one of two issues:

1. The existing end-devices are already connected to existing routers in the WSN. Hence this mobile node can only communicate with the router nodes.
2. In systems where multiple mobile targets that need to be tracked. End-devices in a given area may already be connected to a mobile target. Consequently, a second mobile node moving into the given area will not be able to connect with the end-devices until the first mobile node is disconnected.

In this chapter, the tracking system proposed in Chapter 3 is extended to be able to track multiple mobile targets through ZigBee standard. Moreover, a possible tracking solution presented to the problems of ZigBee networks, when the problems arise due to issues 1 and 2.

This chapter addresses the research challenges in localisation and tracking of multiple mobile targets through the implementation of a ZigBee based real-time surveillance applications. The proposed ZigBee based tracking system is based on a RF localisation method. However, the interference issue can affect the localisation system and hence offers less accurate localisation estimation. A time management method is proposed in this chapter in order to overcome the interference limitation through localising target nodes in WSN.

6.2 Tracking Multiple Mobile Targets

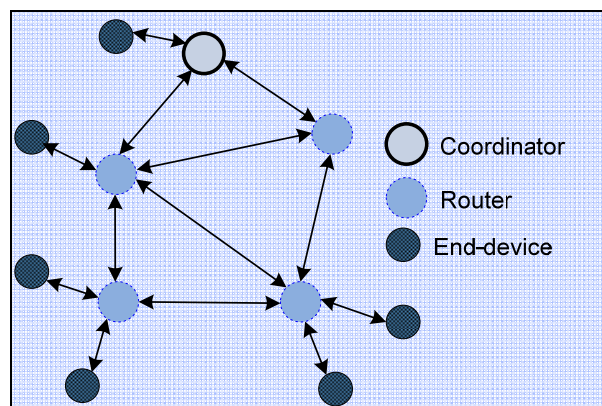

Figure 6-1: Mesh ZigBee network

The proposed tracking system is based on ZigBee network standard. As stated before, ZigBee network offers three types of devices (coordinator, router, and end-device nodes) as depicted in Figure 6-1. In this section, an approach for tracking

multiple mobile targets is proposed when a tracking is required by using the full ZigBee roles. For simplicity, the tracking process is divided into five phases, as shown in Figure 6-2. Table 6-1 shows several parameters definition.

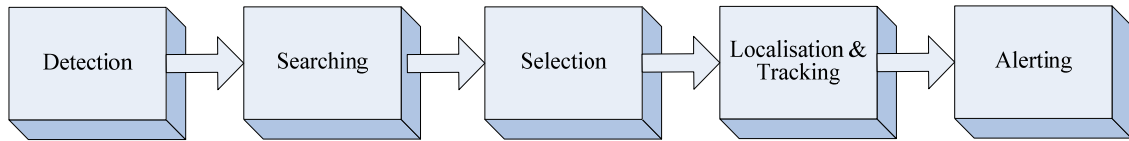

Figure 6-2: Tracking process

Table 6-1: Parameters definition

<i>Parameter</i>	<i>Definition</i>
br_i	beacon router node with serial number i
be_i	beacon end-device node with serial number i
μ_{ef}	the average environment factor between three reference nodes, where they form a triangle
dm_j	Dynamic mobile node with known position, computed based on other reference nodes

6.2.1 Detection

Detecting the first position of the mobile target can help in reducing the localisation error. This process can be achieved by fixing router nodes at each entrance in the tracking area. As soon as one of them receives signals from any target node, it reports this to the coordinator and all beacon nodes in its vicinity.

6.2.2 Search

During the search stage, the mobile target tries to find three beacon nodes to which it can connect to triangulate its position. This consists of three stages:

1. The mobile target node tries to find three router nodes to connect with initially, as they give the highest localisation accuracy. If less than three router nodes are available, the mobile target node connects with any available routers if any as depicted in Figure 6-3, and then starts stage 2.
2. The mobile target node searches for available end-devices in range and connects with sufficient end-devices. This happens when the mobile target asks the closest router if it is connected to any end-devices, if so, the mobile target asks the router to disconnect its end-devices, as depicted in Figure 6-4. The disconnected end-devices can be

connected to the mobile target as shown in Figure 6-5. Therefore, the total number of routers n_r and end-devices n_e connected to the mobile target equal three. Another problem arises when the tracking of multiple mobile targets is required through the same area. As shown in Figure 6-6, the mobile targets MT_1 and MT_2 are connected to $\{br_1, be_3, be_4\}$ and $\{br_1, be_6, be_7\}$ respectively. However, if there are not enough end-devices to satisfy Equation (6-1), as the mobile target MT_3 can only connect to a single router node, then the mobile target enters stage 3.

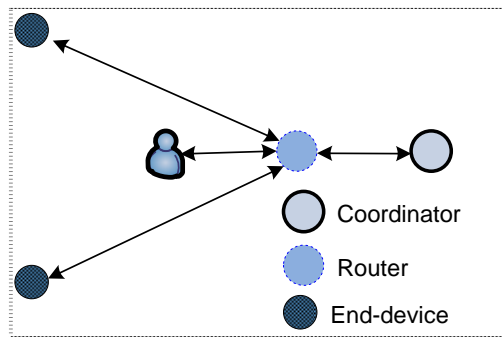

Figure 6-3: Communication problem using ZigBee

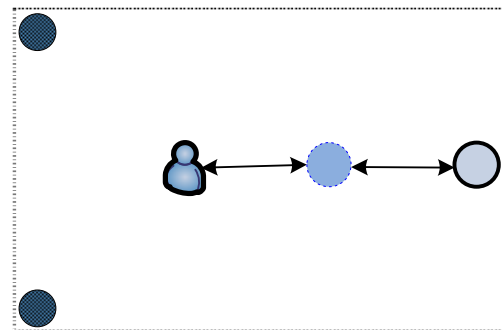

Figure 6-4: Disconnection process

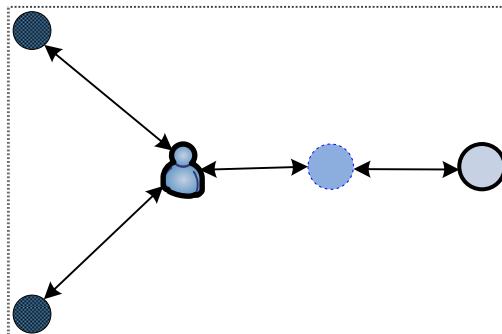

Figure 6-5: Connection process

$$n_r + n_e \geq 3 \tag{6-1}$$

3. The mobile target node searches for other mobile targets in range, so that the total number of routers n_r , end-devices n_e , and dynamic mobile targets n_d connected to the mobile target are equal to 3. However, if there are not enough beacon nodes and dynamic mobile targets in range to satisfy Equation (6-2), then triangulation of the mobile node is not possible.

$$n_r + n_e + n_d \geq 3 \quad (6-2)$$

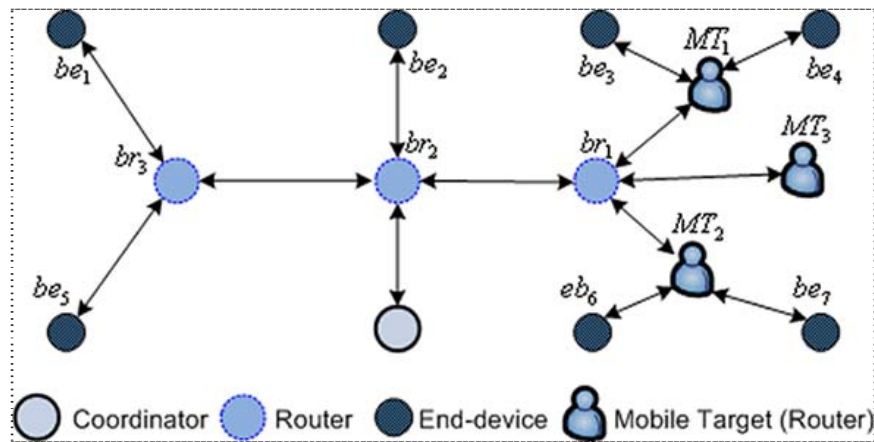

Figure 6-6: Tracking multiple mobile targets problem through ZigBee

Therefore, tracking multiple mobile target nodes can be carried out by dividing the multiple targets scenario into a series of single mobile target nodes, in order to solve tracking multiple mobile targets problem.

6.2.3 Selection

ZigBee Network (NWK) layer provides the mechanisms for joining and leaving the network, applies security to frames, and routes messages to their intended destinations. The discovery of one-hop neighbours and saving of relevant neighbour information are carried out at the NWK layer. Each mobile target node keeps a routing table, which includes information about neighbouring nodes in order to transmit messages to them (Baronti et al. 2007).

After detecting the first position for the target node, the target node has to select 3 beacon nodes in its range in order to triangulate its current location. Through experiments, it has been seen that the indoors transmission range for a Jennic sensor node is 20-25 m. It has been found that localising a target node based

on 3 beacon nodes offers efficient localisation accuracy, compared with localisation based on more than 3 beacon nodes. The difficulty in calculating the localisation error increases as the number of environment factors increases. Moreover, using a large number of environment factors causes the WSNs energy to be depleted faster. However, it is possible for a mobile target to connect with more than 3 beacon nodes. This results in the problem of which 3 router nodes to choose to use for triangulation.

A RSS based localisation system is proposed in Chapter 3 to reduce the positioning error for localising a single target node based on the ZigBee network standard in indoor environment. This system works by finding out the relationship between RSS values and distances for each pair of beacon nodes in order to predict the environment characteristics. The calculated environment factor ef between beacon nodes can offer some prediction information to a mobile target node in order to increase the localisation accuracy. The proposed system was implemented with a small number of beacon nodes (3 beacon nodes). In this chapter, the method is expanded to make it reliable when used with a high number of nodes.

There are 4 different triangles $(\Delta a_1, \Delta a_2, \Delta a_3, \Delta a_4)$ which can be formed as shown in the tracking area in Figure 6-7. Each mobile target MT_k (where $k=1,2,\dots,m$ and m is the total number of mobile targets) is covered by total number of beacon nodes n . The average environment factor μ_{ef} is calculated between each 3 adjacent beacon nodes when they form a triangle shape, as shown in Equation (6-4). For instance, in Figure 6-7, if a mobile target MT_i can talk to these beacon nodes (b_1, b_2, b_4, b_5) there will be two possible triangles Δa_1 and Δa_2 which consist of (b_1, b_4, b_5) and (b_1, b_5, b_2) respectively. Equation (6-5) has to be applied in order to find the right triangle which includes the target node.

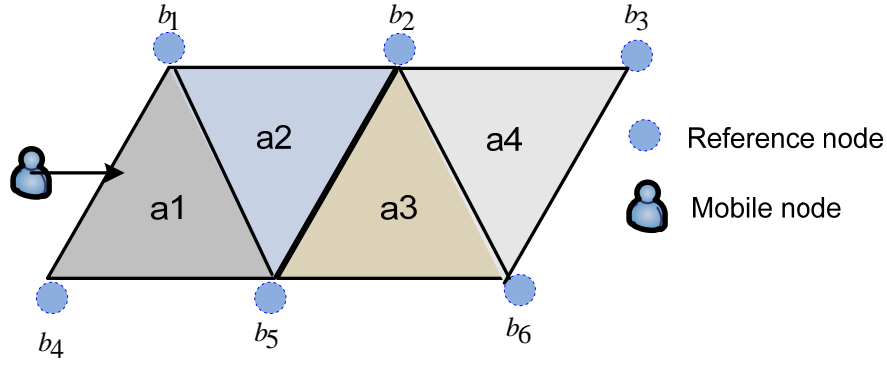

Figure 6-7: Localisation through area of triangles

$$ef_{ij} = \left(\frac{rss(b_i, b_j)}{dist(b_i, b_j)} \right) \quad (6-3)$$

$$\mu_{ef} = \frac{ef_{1j} + ef_{2j} + ef_{3j}}{3} \quad (6-4)$$

$$dist(b_i, MT_l) = \frac{rss(b_i, MT_l)}{\mu_{ef}} \quad (6-5)$$

where j is the beacon node serial number, $j = \{1, 2, 3\}$, $rss(b_i, b_j)$ refers to the received signal strength value between beacon nodes b_i and b_j , and $dist(b_i, b_j)$ refers to the distance between beacon nodes b_i and b_j .

6.2.4 Localisation and Tracking

In this phase, two issues are discussed: interference and localisation, as both of these issues affect the localisation accuracy.

6.2.4.1 Interference Issue

The interference affects coverage and capacity, and limits the effectiveness for the localisation system. In this section, the interference among ZigBee-sensor nodes is considered. Through experiments, it was found that transmitting packets from two beacon nodes to one mobile target at the same time can apparently increase the

localisation error, as sometimes both of the transmitting nodes use the same radio channel.

There are two methods to overcome the interference between sensor nodes. The first one is the frequency diversity which means that each message has to be transmitted separately at two different frequencies. The work presented by Reichenbach and Timmermann, (2006) includes an indoor localisation system based on a RSS technique. The proposed system was tested using Chipcon module which feature a simple frequency switching between 868.28 MHz and 915.03 MHz. Transmitting each message in two different frequencies from all beacon nodes to each mobile target adds additional cost and power-consumption.

The second method includes transmitting messages to the mobile node in several time slots in order to avoid collision between adjacent beacon nodes. For instance, if the mobile target is covered by three beacon nodes, then the mobile target will manage to communicate to each beacon node at each time as shown in Figure 6-8. This reduces the interference between beacon nodes and consequently improves the localisation accuracy.

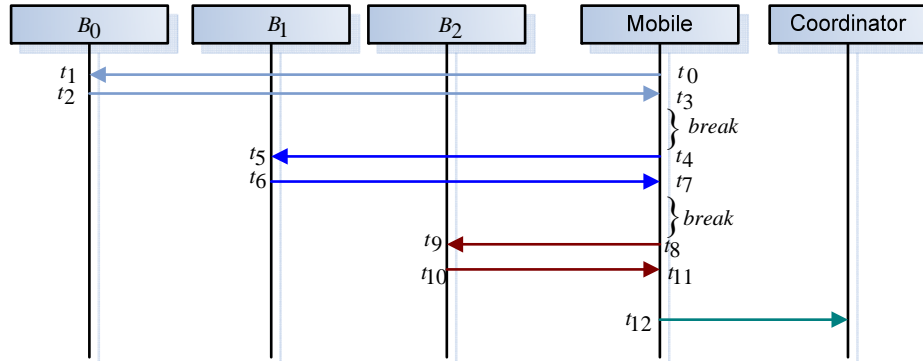

Figure 6-8: Time management method for mobile target node

6.2.4.2 Localisation Issue

RSS based localisation systems have been deployed widely in several works. The selection process requires finding out the suitable triangle which includes the target node. Once the correct area has been identified, the localisation method in Chapter 3 is used to further reduce the localisation error and select which beacon node the mobile target is closest to in the given area.

A minimum of three beacon nodes are needed to estimate the target's location. A triangulation method is applied to calculate the final position for each target node.

6.2.5 Alerting

After calculating the mobile target's position, each mobile target has to send its current coordinates to the coordinator, and then the coordinator must alert beacon nodes which lie near the mobile's target trajectory by sending them "warning" messages so they are aware of the approaching of mobile target nodes and can take proper actions, for instance, activating the beacon nodes in the mobile's target trajectory.

Alerting involves activating appropriate beacon nodes in the network in order to track the target nodes. As soon as any router node br_i receives a high RSS value from the mobile target node MT_j , then the beacon router br_i has to alert the beacon nodes in its range by managing the sleep time for each end-device node, in order to track the mobile target node, as shown in Figure 6-9.

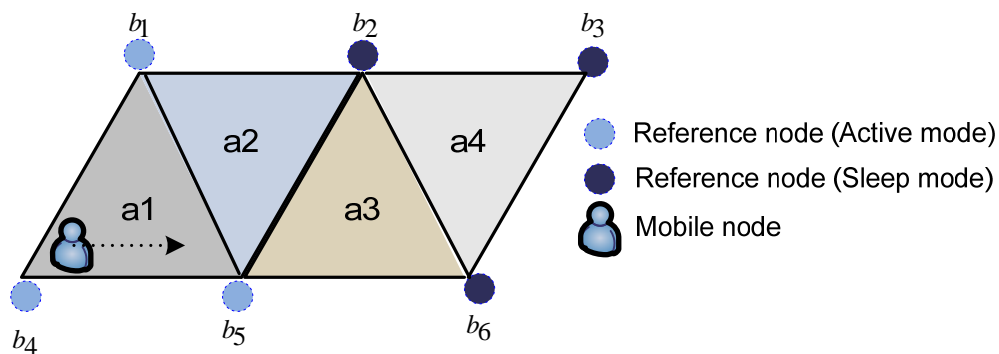

Figure 6-9: Alerting process

6.3 Experiment Setup

The experimental test-bed consists of seven beacon nodes and three mobile targets. First a set of experiments was made to establish the relationship between RSS measurements and the distance values. The achieved relationship can be used to estimate the distance between beacon and target nodes.

6.3.1 Sensor Node Model

Each sensor node has a unique MAC address and location coordinates. For each beacon node, the MAC address with its current location was registered and stored them in an Access DB. This data has to be available to the coordinator, in order to display the position for the mobile target node. The pseudo code runs on

each beacon router and end-device nodes are depicted in Figures 6-10 and 6-11 respectively.

Algorithm 1: Code runs on each reference router node

```

01: while (IsMobileAround)
02:   { transmit("ack"); //message to mobile nodes
03:     // on request
04:     disconnect_end_devices(); // on request
05:     // from router node
06:     transmit("ef"); // to all mobile nodes
07:     transmit("wake up"); // to all beacon nodes
08:   }
09: Timer_Calc_EF(every 10 seconds)
10: { ef = RSS / dist; }
11: end

```

Figure 6-10: Pseudo code runs on each beacon router node

Algorithm 2: Code runs on each end-device node

```

01: while (awake)
02:   { transmit("ack"); // message to mobile nodes
03:     // on request
04:     while (disconnected)
05:       { search_for_parent(); }
06:     transmit("high RSS"); // to sink node
07:   }
08: end

```

Figure 6-11: Pseudo code runs on each end-device node

6.3.2 Experiment Test-bed

For evaluation purposes, the proposed localisation system was deployed in the FK research area lab (Figure 6-12 shows the office test environment 41.5×11.3 m), and it consists of 7 beacon nodes distributed over the FK lab as depicted in Figure 6-13.

In the experiments, the sink node is considered as a coordinator and does not participate in the localisation process, the only task for it is to receive localisation information from mobile nodes and transmit this information to a laptop to display the current positions for each mobile target node.

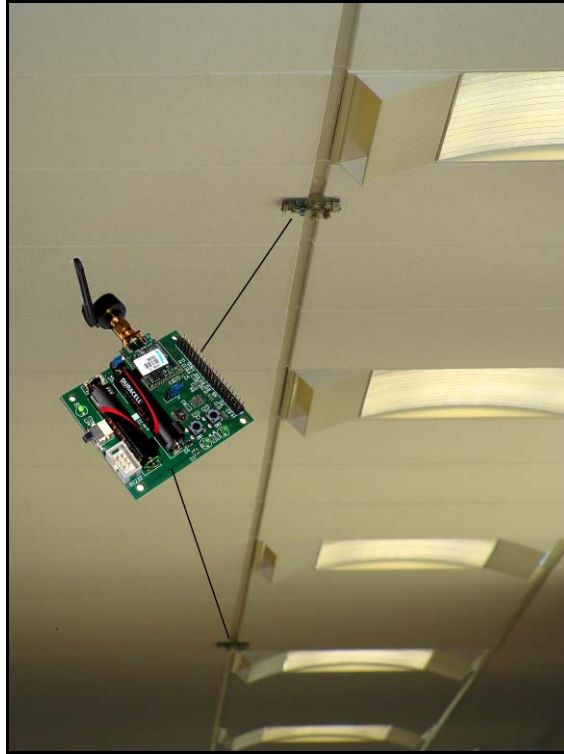

Figure 6-12: FK office test environment

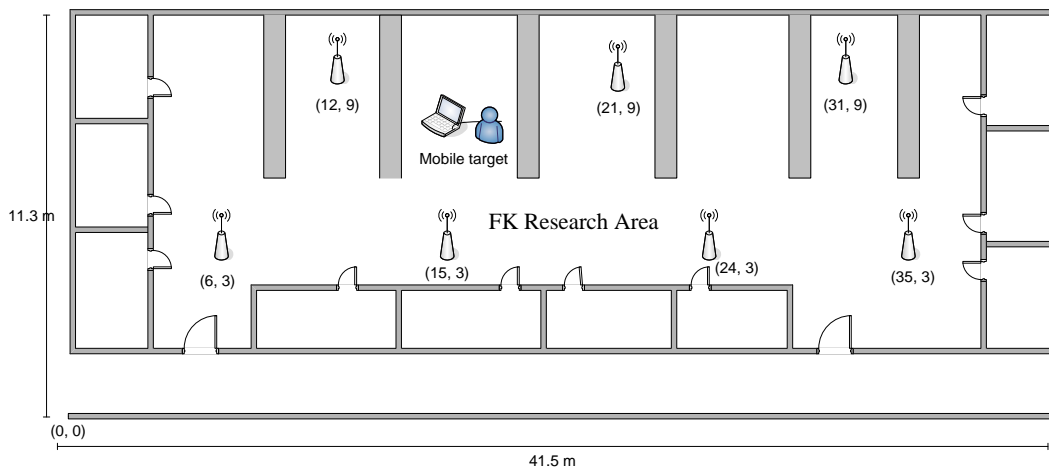

Figure 6-13: FK office test layout

6.3.3 Target Node Model

The mobile target node device is the same as the beacon node. It has the ability to calculate its current location based on the collected readings from the beacon nodes in its range, and transfer its current location to a coordinator. The mobile target node is connected to a laptop computer via serial cable in order to display its current position on a map, and it's responsible for finding its current coordinates and subsequently transmitting it to a coordinator node every 5 seconds. The mobile target algorithm is shown in Figure 6-14.

Algorithm 3: Code runs on each mobile node

```

01: search(routers);
02: if (noOfRouters < 3)
03: { check_endDevices(); }
04: if (noOfRouters > 3)
05: { select_three_references();
06:   aveEF = (ef1 + ef2 + ef3) / 3;
07: }
08:
09: Timer_Transmit(every 1 second)
10: { for (i = 1; i <=3 i++)
11:   transmit("req", rn(i));
12: }
13: end

```

Figure 6-14: Pseudo code runs on each mobile target node

6.4 System Evaluation

This section reports results obtained through real experiments conducted in an indoor environment using Jennic sensor devices. The proposed system was evaluated through measuring the localisation error, evaluating the efficiency of tracking multiple mobile targets, evaluating the interference between sensor nodes, and measuring the power-consumption.

6.4.1 Tracking Accuracy

The localisation error E was calculated every 5 seconds based on measuring the difference between the actual position and the approximated position for each mobile node MT_j .

For simplicity, three different localisation accuracy classes were proposed, and each mobile target has to be assigned to one of these classes. The proposed system will deal with the mobile target nodes as a First Come First Serve principle. Figure 6-15 depicts the status for each mobile target and the assigned class.

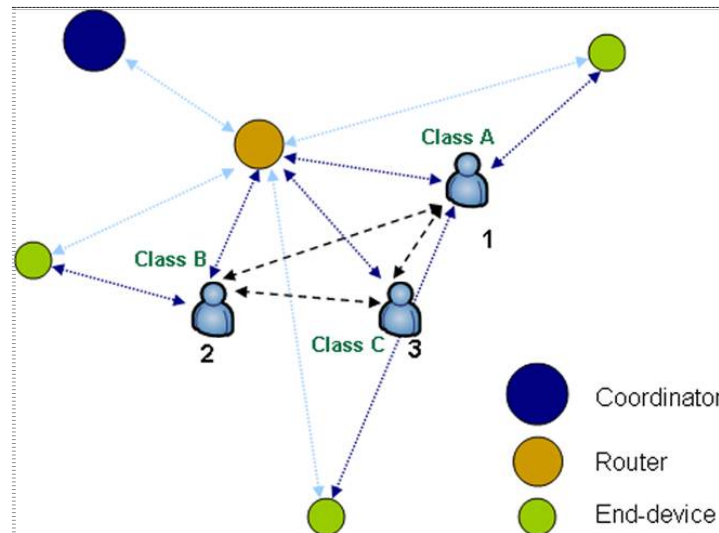

Figure 6-15: Tracking process through ZigBee network

The first case (Class A) includes a single mobile node MT_j and 3 beacon nodes (b_i, b_{i+1}, b_{i+2}) in its range. In this case, the mobile target can communicate directly to the three beacon nodes and computes its current position. This class offers the best localisation accuracy, as the mobile target node is covered by 3 beacon nodes with known positions.

The second case (Class B) includes a single mobile node MT_j with unknown position, another single mobile node MT_{j+1} with known position, and 2 beacon nodes (b_i, b_{i+1}) . Through experiments, the tracking accuracy is lower than Class A, as the mobile target node is covered by 2 beacon nodes with known position, and 1 dynamic beacon node.

The third case (Class C) involves a single mobile node with unknown position MT_j , other 2 mobile nodes with known position (MT_j, MT_{j+1}) and 1 beacon router node b_i . Class C offers the worst tracking accuracy as the mobile target nodes is covered by 1 beacon node and 2 dynamic beacon nodes.

Table 6-2 shows the tracking accuracy and localisation error for each class. The tracking accuracy for Class A, B, and C are evaluated in Figures 6-16, 6-17, 6-18 respectively.

Table 6-2: Localisation accuracy for each class

<i>Class grade</i>	<i>No. fixed beacon nodes</i>	<i>No. mobile (dynamic position)</i>	<i>Accuracy (%)</i>	<i>Localisation error (m)</i>
Class A	3	0	70-85	0.2-1.5
Class B	2	1	50-65	1-2
Class C	1	2	40-50	1-3

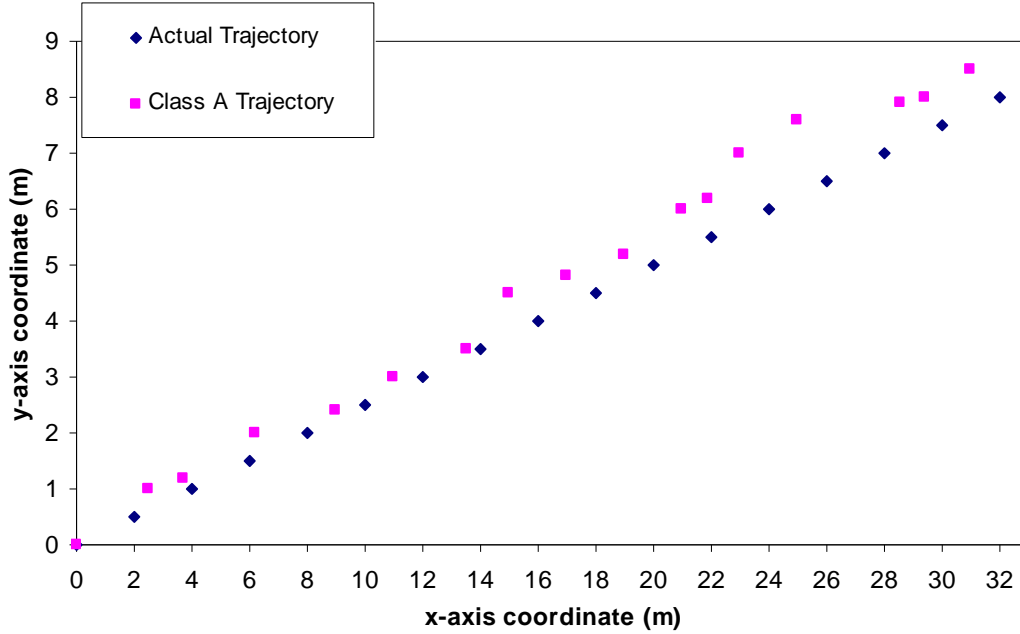

Figure 6-16: Localisation accuracy for class A

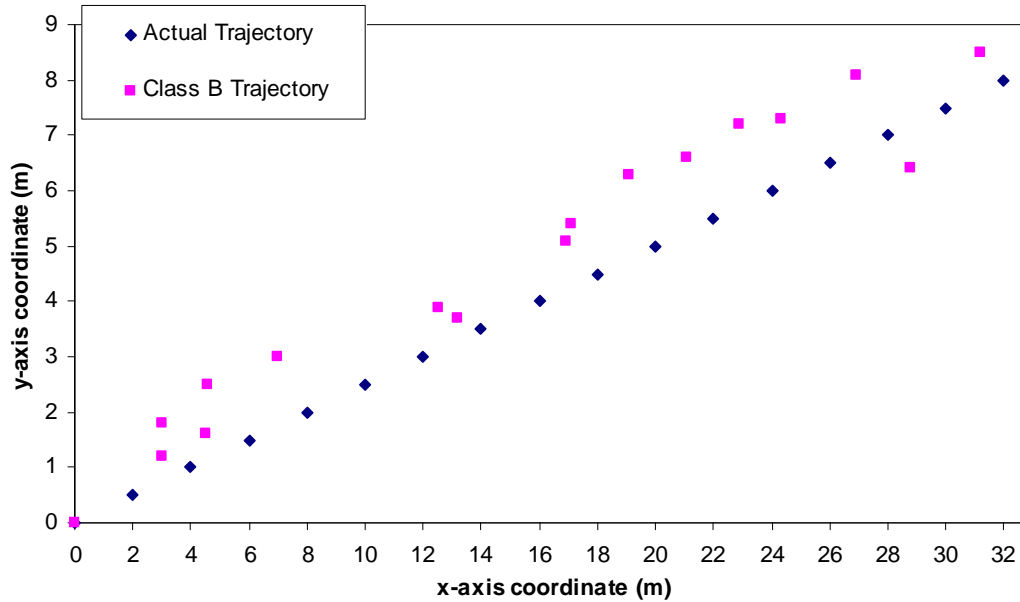

Figure 6-17: Localisation accuracy for class B

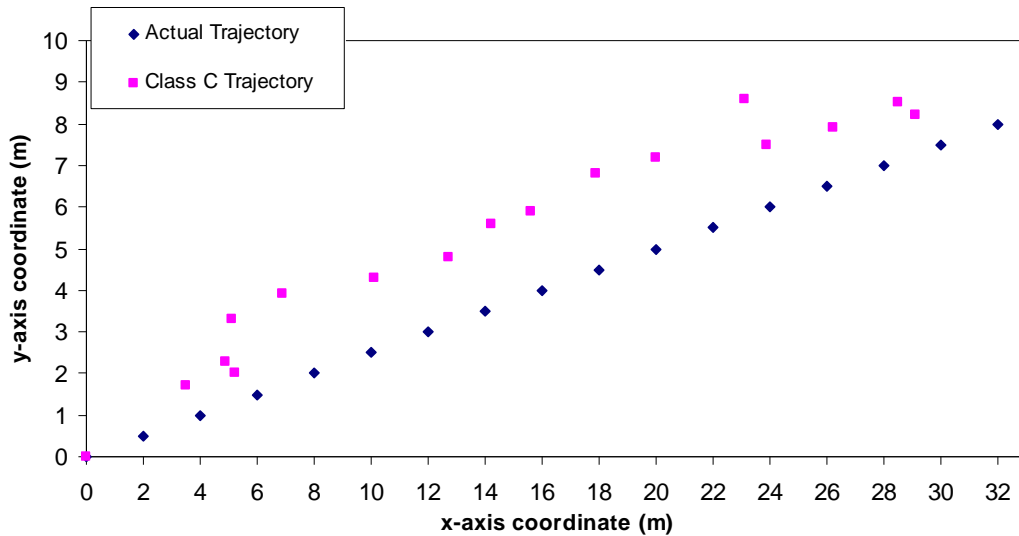

Figure 6-18: Localisation accuracy for class C

6.4.2 Collision Avoidance

In order to validate the interference effect, two experiments were conducted; the first one includes transmitting beacon messages from beacon nodes at the same time. The second experiment works by scheduling transmitting messages to beacon nodes. Figure 6-19 shows the localisation error in both cases.

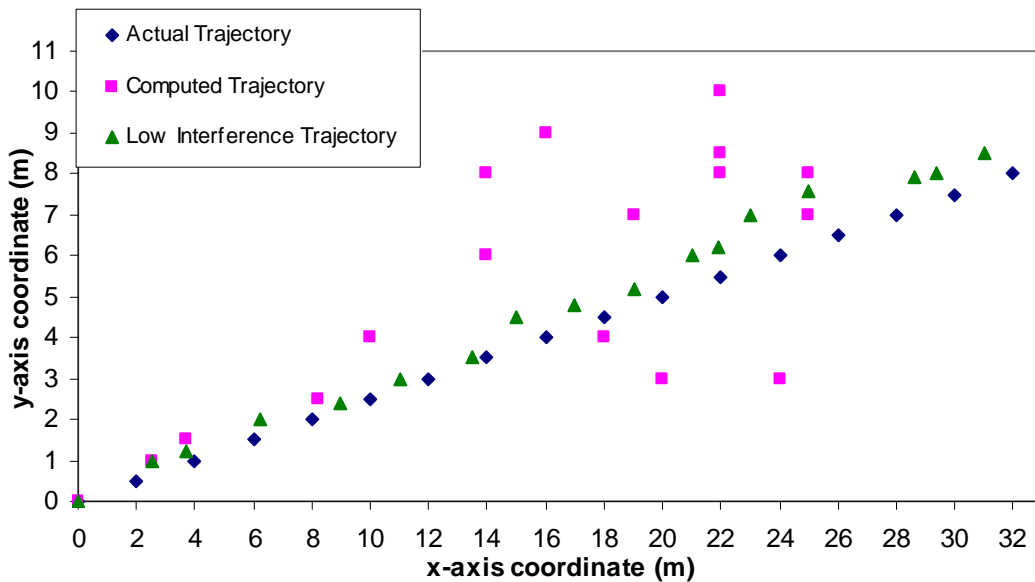

Figure 6-19: Evaluating the collision avoidance effect

6.4.3 Power-consumption

The main idea behind using the full roles of ZigBee network is to minimise the power-consumption for the network. In this section, the total power-

consumption is evaluated for two experiments. The first experiment (A) consists of 6 router devices and a single mobile target moves in the tracking area as shown in Figure 6-20. The second experiment (B) includes 2 router nodes and 4 end-device nodes as depicted in Figure 6-21. The final time for both experiments was 9 minutes, and the initial energy for each sensor node was 4mA.h . The power-consumption P is represented on Equation (6-6). Table 6-3 show the power charge in microampere mA for each phase.

Table 6-3: Power-consumption for each phase

<i>Phase</i>	<i>Charge (mA)</i>
Wake from Sleep	9.00
Transmit Data	44.00
Receive Data	49.00
Sleep (RAM contents not held)	0.0035
Sleep (RAM contents held)	0.025

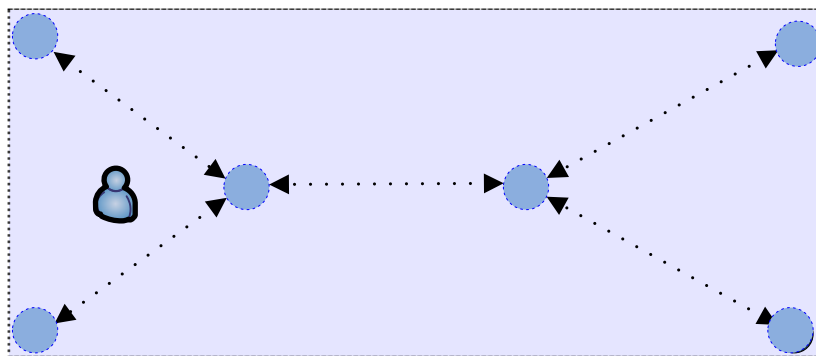

Figure 6-20: Tracking process through experiment A

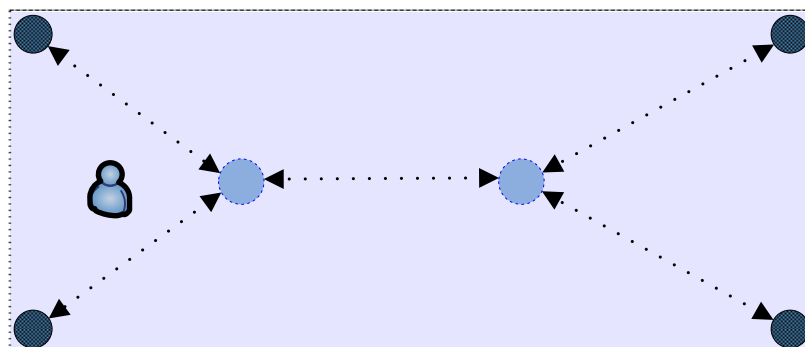

Figure 6-21: Tracking process through experiment B

$$P = (nm \cdot p \cdot \frac{ft}{4}) + (na \cdot p_{act}) + ((n - na) \cdot p_{drm}) \tag{6-6}$$

where nm refers to the total number of messages transmitted over the network, p is the power required for sending and receiving a single packet, ft is the final time, na is the total number of beacon nodes in the active mode, n is the total number of beacon nodes in the tracking area, p_{act} is the power consumed in the active mode, and p_{drm} is the power consumed in the sleep mode.

Involving end-device nodes in the tracking process can reduce the total power-consumption of ZigBee networks. Figure 6-22 shows the difference in power-consumption for the two experiments (A and B). As shown, experiment B offers long battery life than experiment A, as end-device nodes can go to sleep mode as soon as they have completed the required tasks.

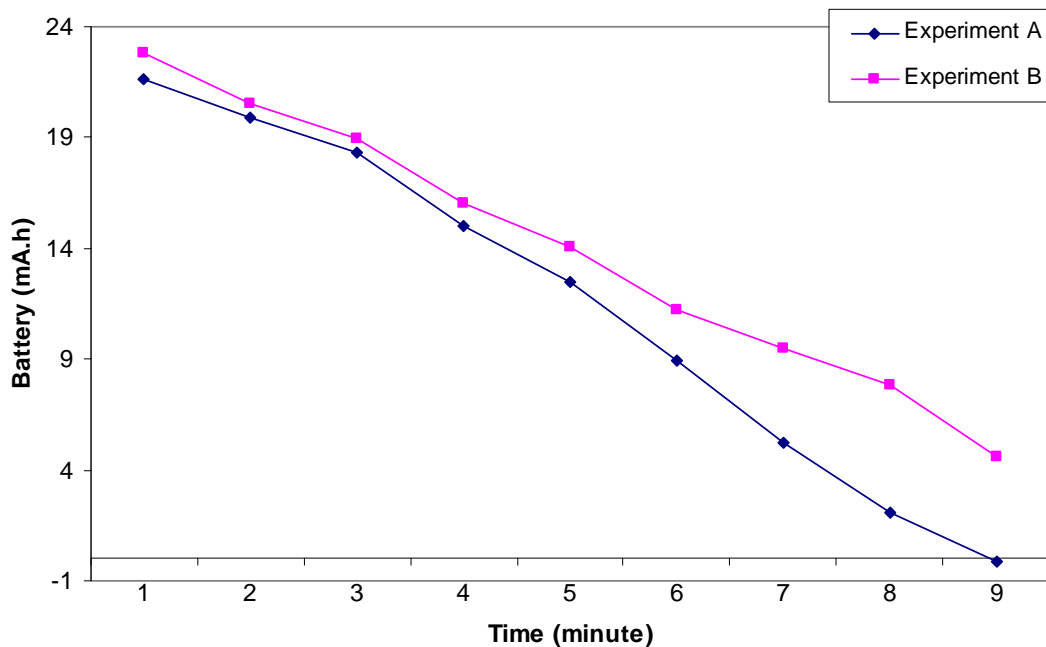

Figure 6-22: Evaluating the power-consumption for experiments (A & B)

6.5 Discussion

Tracking through ZigBee network standard has received low attention recently due to the limited communication capabilities of such a network. The main advantages behind deploying the proposed tracking system with ZigBee network is the simplified implementation process with the provided protocol suit of ZigBee. Moreover, the low complexity, fast calculation, and the minimum resource requirements, make ZigBee standard an ideal network solution for wireless sensor applications.

Several localisation and tracking applications have been proposed recently for several applications. The implementation of previous studies was limited in scale, as the system proposed by Reichenbach and Timmermann (2006), which was implemented in a small area (300×300 cm), and the system proposed by Sugano et al. (2006) was implemented where the density of nodes was 0.27 nodes/ m^2 . The work proposed in this chapter was implemented in a realistic environment (11.3×41.5 m) where the density of beacon nodes is low (0.05 node/ m^2).

ZigBee network standard can achieve a low power-consumption when the density of end-device nodes is greater than density of router nodes, as the end-device nodes can go to a hibernation mode as soon as they have completed the required task. End-device nodes are a power-efficient solution for WSNs. The approaches proposed in (Sugano et al. 2006; Blumenthal et al. 2007; Jang and Skibniewski, 2007) include deploying their systems based on router and coordinator devices to track a mobile target. End-device nodes were not deployed in their experiments, and that increases the power-consumption and cost for tiny sensor networks.

The implemented work by Blumenthal, et al. (2007) and Alhmiedat and Yang (2008), concentrate on tracking and localising a single target node in indoor environment. The mobile target was considered as a coordinator in their experiments, which limits the proposed solutions from tracking multiple mobile targets. The system proposed in this chapter considers the mobile target as a router node in order to track multiple targets nodes synchronously.

The system implemented in this chapter does not require strict time synchronization, nor any need for coordination between the beacon nodes, and depends only on the received signal values with no need for any additional hardware. The proposed approaches in (Jung and Sukhatme (2001); Li et al. (2002); Takahashi et al. 2008b) offer efficient ZigBee-based localisation approaches, but each one requires additional devices to be attached to every single node.

6.6 Summary

In this chapter, the ability of tracking multiple mobile targets using ZigBee was investigated, in order to reduce the power-consumption for the whole ZigBee

network. The presented system was deployed in indoor environment where GPS, ultrasound, and infrared technologies are inefficient.

A ZigBee based tracking system has been designed and implemented in this chapter to track multiple mobile targets wherever the density of router and end-device nodes is low. The proposed system is scalable to work in a very large distributed network of sensor nodes. The implemented system has overcome some of tracking limitations such as localisation accuracy, communication cost, interference, and the ability to track multiple mobile targets simultaneously.

A RSS based localisation method is applied in the proposed tracking system with no need for any additional hardware and with minimum power cost. End-device nodes are incorporated in the tracking process in order to offer reasonable accuracy wherever the density of router nodes is low.

Finally, a simple solution has been proposed to overcome the interference problem. The proposed solution includes managing transmitting beacon messages from beacon nodes to each mobile target.

CHAPTER 7

AN ENERGY EFFICIENT TRACKING APPROACH

7.1 Background and Motivation

A ZigBee based tracking system has been proposed and implemented in the previous chapter. The approach offers low power-consumption compared with the existing ZigBee based localisation approaches. However, this chapter concentrates on different energy efficient issues for tracking applications to reduce the total power-consumption.

Tracking systems using a high number of low-cost sensor nodes have been proposed for use in diverse applications including civil, military and wildlife monitoring applications. In tracking applications, each sensor node attempts to send the target's location information to a sink node. Deploying a tracking system with a high number of sensor nodes results in the following limitations: high packet dropping rate, high congestion, transmission delay, and high power-consumption (Vaidyanathan et al. 2004).

In this chapter, the power-consumption issue for tracking applications is taken into consideration. Therefore, to deal with energy efficient target tracking in a WSN two problems should be addressed: First, energy-efficiency to minimise the power-

consumption for the whole WSN. Second, the tracking accuracy to estimate the mobile targets' locations. The approach proposed in this chapter minimises the power-consumption required for tracking applications while achieving real-time tracking with low localisation error. Three metrics are utilised for the purposes of evaluation: the total number of messages transmitted in the network, overall power-consumption, and the quality of the tracking accuracy. The proposed system is implemented using the NS2 simulation environment.

7.2 An Energy Efficient Approach

The proposed system attempts to optimise energy-consumption by minimising both the sampling interval and the number of nodes involved in target tracking, while offering reasonable localisation accuracy. In this section, the system requirements are defined for target tracking applications and identify three performance metrics. Then, several energy-saving strategies are investigated to meet these requirements. A system design is illustrated in detail next.

7.2.1 System Requirements and Metrics

The information of interest regarding the mobile targets includes: position p , direction d , and velocity v . As soon as this information is found, only a small set of sensor nodes are activated while other sensor nodes stay in the sleep mode.

Requirements: consider a network $R = \{b_1, b_2, \dots, b_n\}$ with a total number of beacon nodes n , and $M = \{MT_1, MT_2, \dots, MT_z\}$ with a total number of mobile targets z . nb represents the total number of observer nodes which sense the mobile target MT . $ns = n - nb$ is the total number of beacon nodes in sleep mode. The application requires the sensor network to report the mobile targets' locations to the sink node with low power-consumption and reasonable positioning accuracy.

Problem Definition: knowing the requirements for the mobile tracking application, energy-saving strategies are needed to be developed in order to minimise the overall power-consumption while maintaining realistic tracking accuracy.

7.2.2 Energy Saving Strategies

Minimising the overall number of messages transmitted over the network can reduce the power-consumption of the whole WSN. The first three strategies are aggregation based. Moreover, a simple energy-efficient prediction system is introduced in the latest strategy in order to activate the right set of beacon nodes. Table 7-1 includes definitions for several parameters.

Table 7-1: Parameters definitions

<i>Parameter</i>	<i>Name</i>	<i>Definition</i>
<i>ob</i>	Observer node	A beacon node which senses any mobile target
<i>s</i>	Sink node	A node which needs to be informed about the targets' locations
<i>si</i>	Sampling interval	How often the sink node has to be informed about a target's position
<i>l</i>	Leader node	A node which works as a leader in order to aggregate location information and transmit it to the sink node
<i>v</i>	Velocity	The mobile target's speed
<i>P</i>	Power-consumption	The total power-consumption over a period of time

Strategy One: (Naive) all beacon nodes in the network have to be in active mode in order to sense the mobile target. Beacon nodes which sense the presence of the mobile target MT_j broadcast $\{p_i, q_i(t)\}$ to the sink node, where p_i is the position of beacon node i , and q_i is the quality of the observation at time t . There is no local processing or data aggregation in this strategy. Therefore, this strategy offers the worst energy efficiency, as the sampling interval is very high, since each beacon node has to transmit its reading to the sink node every 2 seconds ($si=2$) (Ditze et al. 2008).

Strategy Two: (Differential based) like the previous strategy, all beacon nodes stay in active mode. Once the mobile target MT_j enters the beacon node's detection range b_i , b_i then reports the observation to the sink node. From this time, it is assumed by the sink node that the beacon node b_i can observe the mobile target MT_j . As soon as the mobile target MT_j leaves the detection range for sensor b_i , then b_i reports this to the sink node. The observer node b_i broadcasts $\{p_i, q_i(t), \Delta t\}$, where Δt is the total duration time for tracking the mobile target MT_j by the beacon node b_i . In this strategy, the sink node is responsible for computing the location of

each mobile target. This strategy includes reducing the power-consumption as there is no need to send messages periodically to the sink node, as stated in the first strategy. In this strategy, the sampling interval si is based on the mobile target's speed, as presented in Equation (7-1), and hence the si is less than in the previous strategy, as observer nodes transmit their reading to the sink node only when the mobile target MT_j enters their detection range and when it leaves. The same idea for this strategy is proposed by Ditze et al. (2008).

$$si = \frac{tr}{v} \quad (7-1)$$

where tr and v are the transmission range, and velocity value respectively.

Strategy Three: (Leader based) in this strategy, a leader node has to be elected each time in order to aggregate the relevant location information and transmit the latest position information to the sink node. Unlike in the previous strategy, as soon as any mobile target MT_j enters the sensor's range b_i , b_i reports this to the leader node instead of the sink node. The leader node l_k aggregates the position information collected from the beacon nodes $\{b_i, b_{i+1}, \dots, b_w\}$, where w is the total number of observer nodes which cover the mobile target MT_j , and informs the sink node. As soon as the mobile target MT_j moves away from any beacon nodes' range b_i , then b_i will report this to the leader node. The leader node l_k will then re-compute the target's position and report that to the sink node. Only when the mobile target moves away from any beacon's range, will the leader node report that to the sink node. A leader node is chosen every time the mobile target moves away from the previous leader.

The sampling interval in this strategy is lower than in the previous strategies, as the leader node needs to aggregate the collected localisation information before transmitting it to the sink node. The sampling interval is presented as follows:

$$si = \frac{tr}{v} - agt \quad (7-2)$$

where agt is the time needed to collect the localisation information from observer nodes.

Strategy Four: (Prediction based) this strategy includes the aggregation strategy 3 with a prediction system in order to reduce the power-consumption of the whole network. Most of the energy is consumed during the idle period waiting for possible targets. Beacon nodes should spend a minimal time in the active mode and stay in sleep mode as long as possible. Therefore, a large amount of energy is saved if the system does not require all the beacon nodes to be activated for the whole tracking period.

The prediction system works by computing the velocity and direction of each mobile target, based on the localisation information collected from the observer node. The leader node has to make these computations and then activate only the essential beacon nodes required to track the mobile targets; other beacon nodes stay in sleep mode. This strategy is described in detail in the next section.

7.2.3 System Design

In this section, an energy saving scheme is presented for target tracking in WSNs. The main stages are presented in this section for the 4th strategy as it offers the lowest power-consumption, as will be shown in the evaluation section. The main stages are depicted in Figure 7-1.

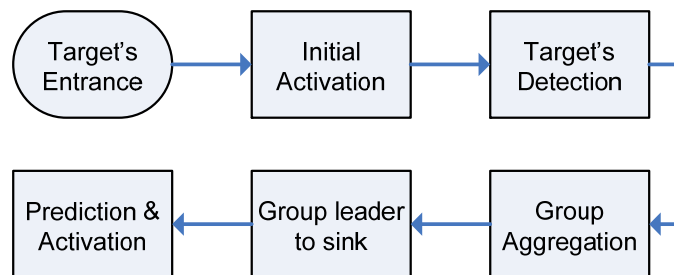

Figure 7-1: Main stages

1. Initial Activation: the beacon nodes are divided based on the activating mode, into two main types: sentry and non-sentry nodes. Sentry nodes include a small number of beacon nodes which have to stay active all the time in order to sense any approaching mobile target. Non-sentry nodes are end-device nodes which stay in sleep mode until they are woken up by a leader node. In this phase, all

beacon nodes stay in the sleep mode when there are no targets to be tracked in order to save power.

2. Target Detection: unlike localisation sensors which are used in traditional tracking systems, binary systems use binary sensors which offer 1-bit of data, representing the presence or absence of the mobile target in the sensing range. Binary sensors are unable to produce any other information, such as distance to the beacon node or direction of arrival.

The mobile target position q is estimated through the binary sensor as $q \in \{0,1\}$, where $q=0$ when the target is out of the beacon node's b_i detection range, and $q=1$ when the mobile target is within the range of the beacon node b_i . A centroid method is used to find the final position for each mobile target. The final position can be calculated based on Equations (7-3) and (7-4).

$$x(MT) = \frac{\sum_{i=0}^k x_i}{k} \quad (7-3)$$

$$y(MT) = \frac{\sum_{i=0}^k y_i}{k} \quad (7-4)$$

where $x(MT)$, $y(MT)$ are the x-coordinate and y-coordinate for the mobile target MT , and k is the total number of observer nodes.

3. Group Aggregation: the proposed system is designed to work with a ZigBee network. Therefore, every end-device node in each group belongs to one, and only one, router node. The proposed model includes dividing the wireless sensor area into small groups. Each group includes a number of end-devices and one or more router nodes; the group is represented by a single leader node which has the responsibility of aggregating the localisation reports from observer nodes, and transmitting the target's position to the sink node.

Each group can be in either the active or the inactive state at a specific point in time. The active group includes activating all the beacon nodes in that group, while the inactive state includes deactivating the beacon nodes in that group. The leader node has to have the following characteristics:

1. High energy, over a specific threshold.
2. It has to be a router node.
3. It has to be in the mobile target's trajectory.
4. It has a large number of sub-nodes which sense the mobile target.

4. Group Leader to Sink Report: after the group aggregation, the leader node aggregates the collected readings from end-device nodes and reports a single message to the sink node. The aggregation function is typically simple as it needs only to find out the average of the mobile target's position based on the location information collected from observer nodes.

The sink node is responsible for computing the mobile target's trajectory. A Kalman filter is used to establish the mobile targets'. This is a recursive filter that assesses the state of a dynamic system from a series of noisy measurements. The Kalman filter takes advantage of the dynamics of the target to remove the consequences of noise and to offer a good estimation (Ditze et al. 2008).

5. Prediction and Activation: tracking based on a single beacon node offers low localisation accuracy; a group of sensors have to be collaborated in order to track and locate the target's position. A group of end-device nodes needs to be activated as soon as one of the group's members detects a mobile target. Before activating a set of beacon nodes, a prediction method has to be applied first in order to predict the future movement of the mobile target and then activate the right set of beacon nodes. This stage includes three main phases: A) Prediction mechanism, B) Activation mechanism, and C) Recovery mechanism.

A) Prediction mechanism: the idea of the prediction phase is that a beacon node that is not performing the duty of mobile tracking should stay in sleeping mode as long as possible. Meanwhile, a beacon node which has a mobile target in its range, known as an observer node, should try to wake up the beacon nodes in its vicinity to track the mobile target. The leader node is responsible for activating a set of beacon nodes in the mobile target's trajectory based on the speed and direction of each mobile target. The prediction is based on the direction and speed of mobile targets. The velocity v can be computed based on Equation (7-5), and direction d can be identified based on measuring the distance between two points the mobile target passed through.

$$v = \frac{|p_t - p_{t+u}|}{\Delta t} \quad (7-5)$$

where p_t is the position coordinate for the mobile target at time t , u is a time unit, and Δt is the difference between t and $t+u$.

B) Activation mechanism: activation can be achieved as soon as the leader node l_k predicts the future movement of the mobile target MT_j , then l_k will send activating messages to the next leader node l_{k+1} in order to activate its sub-nodes to track the mobile target. As soon as the new leader l_{k+1} or any of its beacon nodes detects the mobile target MT_j , then l_{k+1} will send a confirmation message to inform the previous leader l_k that the mobile target is in its vicinity. Meanwhile, the leader node l_k requests all sub-nodes to go into deep sleep unless one of them is sensing the mobile target.

The leader node may wake up some destination beacon nodes s seconds before the target enters their area. s is based on the speed of the mobile target; it is usually very small. The activation procedure is based on the mobile target's velocity as it is based on the following equation:

$$s = \frac{dst - c}{v} \quad (7-6)$$

where dst and c is the distance between the target node and the new beacon group, and distance constant in order to activate the beacon nodes which set in the mobile target's trajectory.

In this section, an activation heuristic mechanism is proposed which is used to activate a set of beacon nodes. The proposed mechanism called Heuristic All_Routers. This mechanism includes activating the beacon nodes in the trajectory of the estimated position. Additionally, the observer nodes also inform the router nodes surrounding the trajectory in order to wake up their sub-nodes.

C) Recovery mechanism: the proposed system needs a recovery mechanism to relocate the missing mobile target in cases when the beacon node fails or the mobile

target is lost. In such a case, the leader node will wake up the previous beacon nodes and other leader nodes in its range. In this mechanism, the proposed system applies Heuristic All_Routers, but if the All_Routers recovery fails, then the observer node will wake up all the beacon nodes in the network for a mobile relocation which ensures a 0% missing rate. The beacon nodes can be woken up using a recovery message which is transmitted via an ultra low energy paging channel.

7.3 Implementation

In the previous section, the design and development are outlined of an energy-efficient WSN based tracking system. Simulations were carried out in order to evaluate the proposed strategies. This section presents the simulation environment, network topology, the target model, and the beacon model. The proposed model was evaluated using an NS2 simulator. For evaluation purposes, relevant parameters from actual sensor devices were collected and fed them into simulation runs. Several assumptions were made and are listed below:

1. Perfect spherical propagation.
2. Each sensor node is equipped with a simple detection sensor which offers two possible values: 0 or 1.
3. The mobile target's speed range is 1-5 km/hour.
4. A single packet is required to carry the localisation information.
5. The average communication range is 30 m.
6. Beacon nodes are synchronous.
7. The aggregation time: $agt = 100$ ms.

7.3.1 Network Topology

The simulation model includes 145 beacon sensor devices in a (120×120) m monitored area. The sensing coverage for end-device nodes is 15 m and is 30 m for router device nodes. Table 7-2 includes simulation parameter values.

The proposed tracking system is based on a ZigBee network standard. Three ZigBee components were used in the simulation. The coordinator node works as a sink node to collect information from router nodes while router nodes have the

responsibility for routing messages between nodes; in addition, each router node might work as a leader for a period of time. End-device nodes collect the localisation information about the mobile target and transmit their readings to the router node. Each end-device node can talk to only one router within on hop. End-device nodes spend their time in sleep mode to save energy while router and coordinator nodes have to be active all the time. The sink node is located at the centre of the network; all nodes can reach the sink within an average of two hops.

Table 7-2: Simulation parameter values

<i>Parameter name</i>	<i>Parameter value</i>
Detection range	10 <i>m</i>
Target speed (v)	0.5 - 4 <i>m / second</i>
Transmission range (tr)	15 <i>m</i>
InitEng	2.00 <i>mA.h</i>
rxPower (p_{rx})	49.00 <i>mA</i>
txPower (p_{tx})	44.00 <i>mA</i>
p_{act}	12.80 <i>mA</i>
p_{drm}	0.0035 <i>mA</i>
Packet Size	127 bytes
Simulation time	180 <i>seconds</i>
Number of nodes	145
Antenna type	OmniAntenna
Radio model	TwoRayGround
Grid size	120 × 120 <i>m</i> ²
Distance between neighbours	10 <i>m</i>
Routing protocol	AODV
MAC Protocol	MAC/802.15.4
System loss	1.0

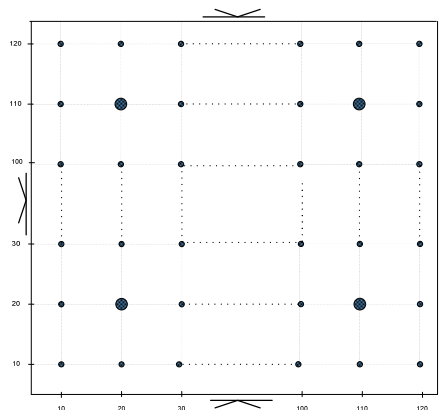

Figure 7-2: Sensor network topology

7.3.2 Beacon Node Model

The beacon node model is based on Jennic's wireless sensor device. Each sensor device is equipped with a radio transceiver to communicate with its neighbours. A simple localisation device needs to be deployed with each beacon node and each sensor node has a local processing unit to process the localisation information. End-device and router nodes can perform the localisation operation while the sink node has the responsibility of collecting localisation information from router nodes and producing a trajectory for each mobile target.

7.3.3 Mobile Target Model

In the simulation, it was assumed that the mobile target is a blind target as there is no localisation device attached to it. Mobile targets can enter the tracking area at four location ranges as shown in Figure 7-2. The entry angle is selected to be between -15 and 15 degrees. The mobile targets change the velocity randomly with an average speed of around 3 km/h, which matches the walking speed of humans.

7.4 System Evaluation

In order to produce a long-term tracking system that meets the requirements of several applications, power-efficiency is both essential and critical for WSN tracking systems. As stated above, three main issues have to be evaluated. In this section, the total number of messages, power-consumption and tracking accuracy are evaluated.

7.4.1 Total Number of Messages

In this section, the total number of messages transmitted over the network is evaluated for the first three strategies. In the first strategy, the observer nodes transmit a single message to the sink node every 2 seconds. The total number of messages nm_{loc} which need to be transmitted over the network is presented in Equation (7-7). The sampling interval is high, as the sink node needs to be informed about the mobile target's location every 2 seconds, hence $si=2$.

Fewer messages are transmitted in the second strategy as the observer nodes have to transmit their readings only when the mobile target enters and leaves their

detection range. The total number of messages is presented in the following equation with sampling interval $si = \frac{tr}{v}$

$$nm_{loc} = \frac{nb \cdot ft}{si} \tag{7-7}$$

where nb and ft are the number of observer nodes and the total time of the simulation respectively.

In the third and fourth strategies, each observer node transmits its localisation report to a leader node and then a leader node aggregates the localisation information from observer nodes and transmits a single report to the sink node. In this strategy, two types of message need to be transmitted: local and global. Local messages nm_{loc} include the total number of messages which needs to be transmitted among observer and leader nodes, as presented in Equation (7-7). These messages do not reach the sink node as they are required to be transmitted to the leader node. Global messages nm_{glb} include the total number of messages which reaches the sink node from leader nodes, based on the AODV routing protocol and as presented in Equation (7-8). For both equations, the sampling interval is $si = \frac{tr}{v}$.

$$nm_{glb} = \frac{ft}{si} \tag{7-8}$$

Table 7-3 shows the total number of local and global messages transmitted over the network for three strategies through different sample frequency values. Figure 7-3 presents the total number of messages which needs to be transmitted for each strategy.

Table 7-3: Number of messages transmitted

<i>Strategy</i>	<i>Sampling interval</i>	<i>Local messages</i>	<i>Global messages</i>
Strategy 1	2	381	0
Strategy 2	4.5	166	0
Strategy 3	4.5	165	40
Strategy 3	3.3	218	57
Strategy 3	6.6	114	29

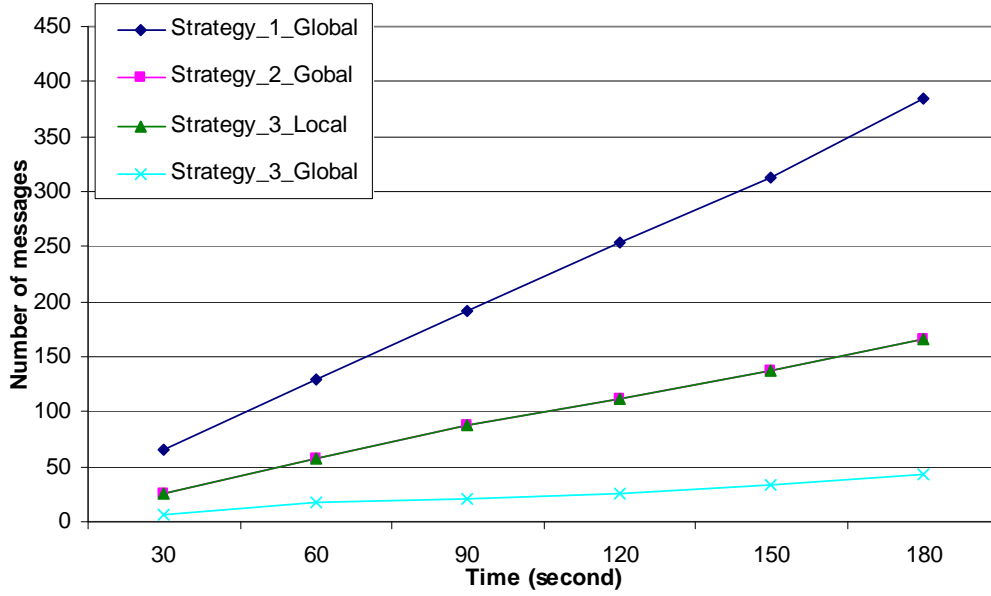

Figure 7-3: Total number of messages for the three strategies

7.4.2 Power-consumption

In the previous section, the total number of messages transmitted over the network is evaluated. Each transmitted packet requires a specific amount of energy; therefore, reducing the total amount of messages transmitted over the network will reduce the total power-consumption. In this section, the total energy consumed over a period of time for each strategy is evaluated.

The first strategy offers the worst power-efficient solution, as the sampling interval is high. The second strategy offers a reasonably power-efficient system, as the sampling interval is lower than the first one. However, the power-consumption P in both strategies is represented in the following equation:

$$P = P(nm_{loc}) + ((n - nb) \cdot P_{act}) \tag{7-9}$$

$$P(nm) = \left((nm \cdot P_{tx}) + (nm \cdot P_{rx}) \right) \cdot h \tag{7-10}$$

where $P(nm)$, P_{rx} , and P_{tx} are the power needed to transmit a number of messages nm , the transmission power, and the reception power respectively.

The collected localisation information from observer nodes is transmitted to a leader node in the third strategy; the leader node aggregates the collected

information and transmits a single packet to the sink node. The power-consumption in the third strategy is based on the target speed and is represented in the following equation:

$$P = p \left(nm_{glb} \right) + ((n - nb) \cdot P_{act}) \quad (7-11)$$

where P_{act} is the power needed for sensor nodes in active mode for every time unit.

As seen in the previous equations, in strategies (1-3) most of the energy is consumed while the beacon nodes are in the active mode. The third aggregation strategy reduces the power-consumption for the observer nodes but a high level of energy is still consumed during the waiting process. The fourth strategy includes reducing power-consumption by deactivating beacon nodes that are away from the mobile targets' trajectory.

In the fourth strategy, only the beacon nodes which sense the mobile target are in the active mode; other beacon nodes have to stay in sleep mode. The power-consumption is represented in the following equation:

$$P = P \left(nm_{glb} \right) + (ns \cdot P_{act}) + ((n - nb) \cdot P_{drm}) \quad (7-12)$$

where P_{drm} is the power needed for sensor nodes in the sleep model for every time unit. Figure 7-4 shows the energy required for each strategy within 3 minutes of tracking time. Strategy four offers an efficient solution for WSN tracking applications.

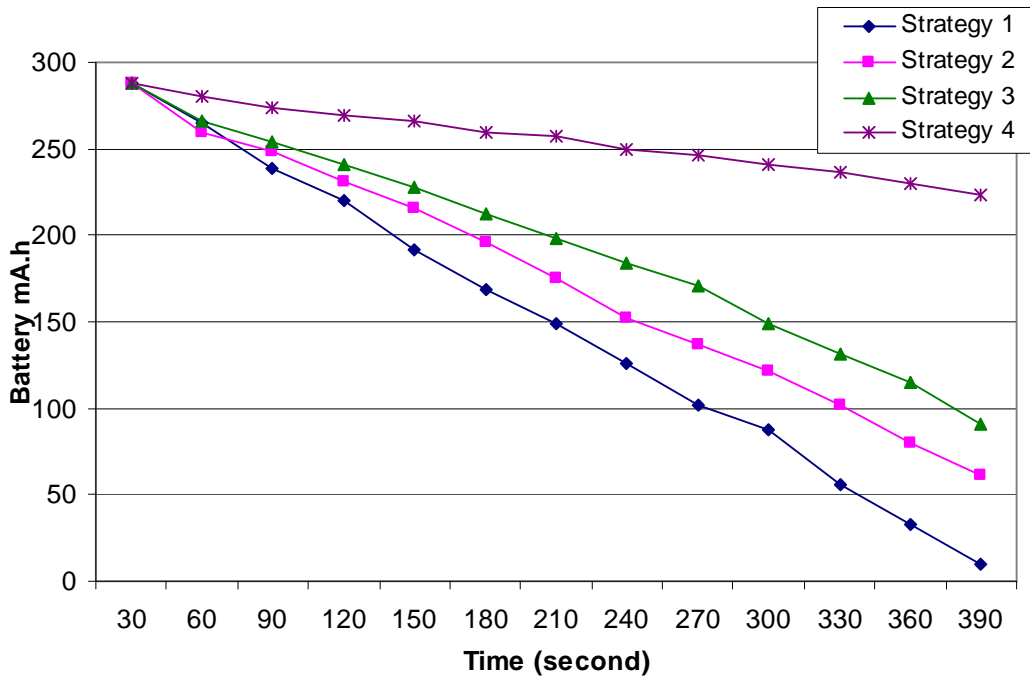

Figure 7-4: Power-consumption for the four strategies

7.4.3 Tracking Accuracy

The accuracy of each strategy is evaluated in this section. Figure 7-5 shows the actual trajectory for the two mobile targets travelling at different speeds. Figures (7-6, 7-7, and 7-8) illustrate the tracking accuracy for the first, second and third strategies respectively.

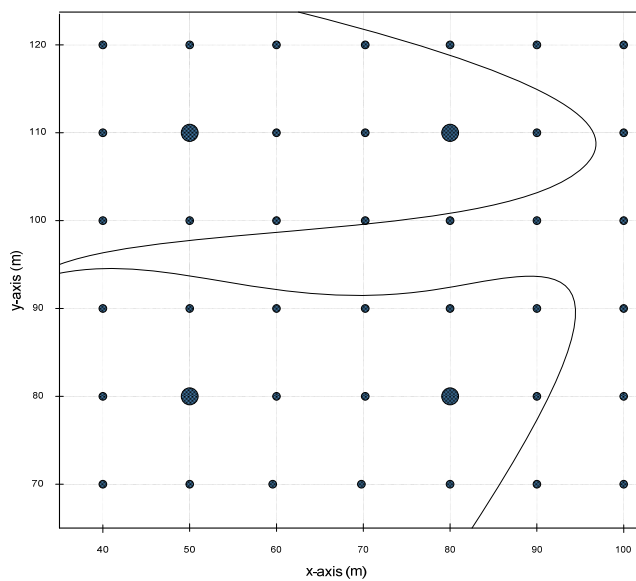

Figure 7-5: Real trajectory

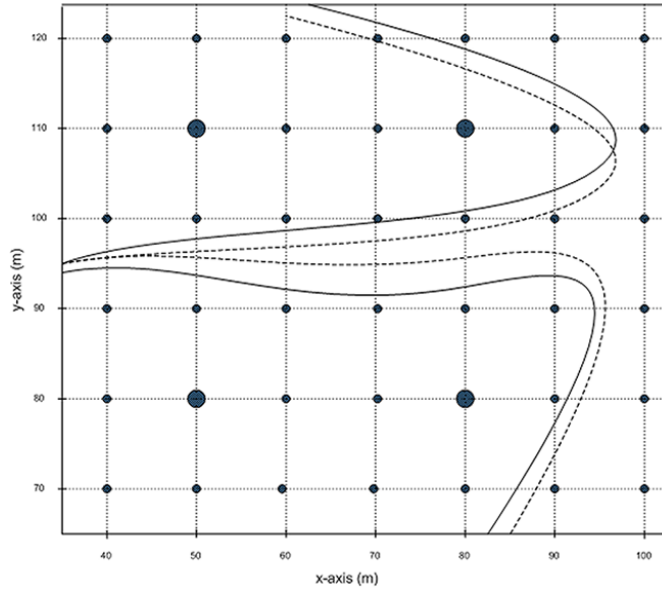

Figure 7-6: Approximated trajectory for strategy 1

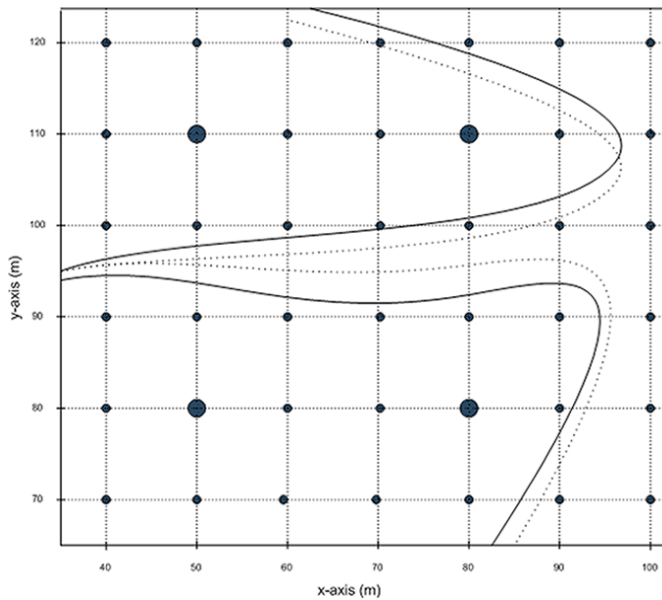

Figure 7-7: Approximated trajectory for strategy 2

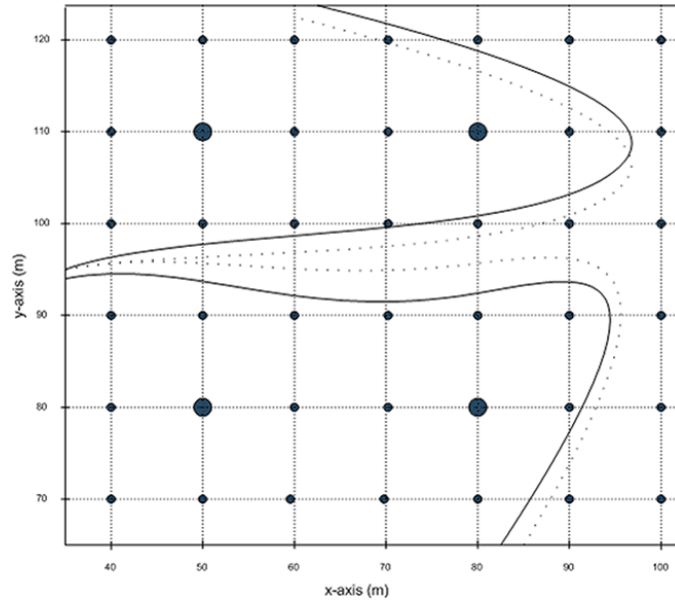

Figure 7-8: Approximated trajectory for strategy 3

7.5 Discussion

Tracking mobile targets through WSNs is a vital research area in wireless sensor applications while power-consumption is a critical issue in designing and developing a tracking system application for tiny sensor networks. In this chapter, four different energy efficient schemes were evaluated in order to reduce the power-consumption for WSN based tracking applications. The first strategy offers the worst power-consumption since each observer node has to send its readings to the sink node. However, this strategy offers high localisation accuracy but suffers from a high packet dropping rate and high congestion in the WSN. On the other hand, the second strategy, proposed by Ditze et al. (2008), reduces the overhead communication as the observer nodes have to inform the sink node when any target enters and leaves their detection area. This strategy offers a lower power-consumption than the previous one.

In the third strategy, a leader node is elected every time the mobile target moves to another area. The leader node is responsible for aggregating the localisation information from observer nodes and for transmitting it to the sink node. This strategy offers lower power-consumption than that presented by Ditze et al. (2008), as the leader node transmits its reading when a new observer node senses any mobile target.

However, the fourth strategy offers the best power efficiency, as it includes activating the beacon nodes that are set in the target's node trajectory while deactivating the other sensor nodes. The proposed heuristic mechanism All_Routers is an efficient activation heuristic one in terms of activating the right beacon nodes with a low missing rate.

The proposed system achieves a critical advantage over the works proposed in (Ditze et al. 2008; He et al. 2008; Vaidyanathan et al. 2004) as it turns off the beacon nodes which are not involved in the tracking process. However, the systems proposed in (Xu et al. 2004; He et al. 2006; Pattem et al. 2003) include prediction based systems that pay no attention to the issue of data aggregation.

Energy efficient approaches are required for WSN applications, as each sensor node has limited energy constraints. The proposed approach in this chapter integrates both the data aggregation and prediction methods that offer low power consumption for WSN based tracking applications.

7.6 Summary

This chapter presented the results of a study concerning tracking, through WSNs, multiple mobile targets simultaneously travelling at different speeds, concentrating on the trade-offs between the amount of messages which need to be transmitted to the sink node, power-consumption and tracking accuracy. In this chapter, several energy-efficient schemes for tracking applications are implemented and evaluated. The data aggregation and prediction methods offer power-efficient solutions for sensor networks and achieve reasonable tracking accuracy.

A novel aggregation strategy is proposed in Strategy 3 and this is integrated with a prediction system in order to reduce the power-consumption for the whole WSN.

CHAPTER 8

CONCLUSIONS AND FUTURE WORK

8.1 Conclusions

It is quite important to know the position of nodes in a communications network where there are a huge number of sensor nodes, but attaching GPS receivers or other complicated sensors to sensor nodes would be an expensive and impractical solution. In addition, tracking mobile targets is a quite challenging issue due to constraints in the communication, computation, and energy features of a sensor network. Therefore, investigating economical localisation algorithms for WSN is a significant task.

The work on this thesis has been motivated by the importance of the location discovery through WSN field. The research efforts have been directed towards designing and implementing localisation algorithms that lead the sensor network to be location aware.

In this thesis, three main issues for tracking applications through WSN's were focussed upon. Firstly, localisation accuracy; two localisation approaches were proposed to localise mobile targets with low localisation error. Secondly, network standard; a ZigBee based tracking approach was implemented to track multiple mobile targets efficiently while using the full ZigBee roles. Thirdly, power-

consumption: two energy efficient approaches were presented and evaluated, to save energy for WSN based tracking applications.

8.2 Outcomes

Although a wide range of localisation approaches have been proposed in the literature, none of them satisfactorily address all of the algorithms' requirements in such a resource-constrained network. The main impetus of this work was to cover some of the gaps in the existing approaches by developing a practical tracking application for WSN.

This work has made contributions for tracking mobile targets through WSN. The main purposes of this thesis were to investigate the possibility of enhancing the localisation accuracy for RSS based localisation approaches by deploying triangulation and fingerprinting methods. Moreover, reducing the power-consumption required for tracking applications by deploying decentralised, data aggregation, and prediction methods was a key concern among several objectives listed in the first chapter. Each objective was achieved, as follows:

8.2.1 Outcome 1: Research current literature

The review of literature revealed that there was a gap in the previous localisation and tracking approaches. The existent published research did not solve the issues related to localisation and tracking through WSN, particularly tracking through ZigBee standard. The majority of the literature was mainly based on simulation experiments, with little attention given to real experiments. This adds some limitations when deploying these systems in real situations. Chapter 2 pointed out the direction for designing and implementing an efficient tracking system in terms of localisation accuracy and power-consumption.

8.2.2 Outcome 2: Improve localisation accuracy

As stated in the literature, most of the existing RSS based approaches are designed to be implemented in outdoor environments. Some others require a specific spherical radio propagation assumption. Therefore, these systems are not efficient solutions for indoor tracking applications.

This objective was achieved by proposing two RSS based localisation approaches. Firstly, a triangulation based approach was proposed in Chapter 3. This system offers reasonable localisation accuracy in indoor environments with obstacles, by predicting the environment characteristics in the tracking area.

Secondly, a fingerprinting based approach was proposed in Chapter 4. The implemented system offers good localisation accuracy for indoor tracking applications, and reduces the total time required for the offline phase.

8.2.3 Outcome 3: Achieve low power-consumption for tracking large numbers of mobile targets

This objective was achieved in Chapter 5. The designed system includes grouping the mobile targets in the tracking area, and selects a single leader mobile for each group. The proposed system achieves lower power-consumption than the existing centralised and decentralised approaches.

The proposed system was implemented using NS2 simulation model, and compared with two existing systems. It was shown that the proposed decentralised approach offers low power-consumption with reasonable localisation accuracy.

8.2.4 Outcome 4: Propose a ZigBee based multiple mobile tracking approach

The fourth objective was to design and implement a ZigBee based tracking approach for tracking the position of multiple mobile targets simultaneously. This was achieved by the system designed and implemented in Chapter 6. The proposed system includes 5 main stages, and overcomes several problems for the existing ZigBee based approaches. This system integrates end-device nodes in the tracking process in order to reduce the energy-consumption for the ZigBee based tracking approaches. Moreover, take the advantages for the distributed end-device nodes when the density of router nodes is low.

The tracking system has three significant advantages compared with those in the existing literature. Firstly, the system is robust, and offers reasonable localisation information. Secondly, in order to address the energy efficiency, the system achieves minimum power-consumption as it is deployed using the full

ZigBee roles (coordinator, router, and end-device nodes). Thirdly, the system overcomes the interference problem by proposing a time management method.

8.2.5 Outcome 5: Propose an energy-efficient approach for tracking applications

The issue of energy efficiency is a critical one for tracking applications, and more power-efficient solutions have received significant attention in recent years. The tracking system has to be an energy efficient one. Practically, that means requiring little computation, especially in terms of communication.

As stated previously, two problems have to be taken in consideration before designing and implementing an energy-efficient tracking approach: power-consumption, and tracking accuracy. For the first problem, a novel data aggregation method was proposed and integrated with a prediction model in Chapter 7. On the other hand, for the second problem, a centroid approach was deployed to estimate the mobile targets' locations. Through simulation experiments, it was shown that the proposed system requires minimum power-consumption while offering reasonable localisation accuracy.

8.2.6 Outcome 6: Implement the proposed approaches

Two experimental environments were used to implement and test the efficiency of the proposed approaches.

1. Real experiments: the proposed approaches in Chapters 2, 3, and 6 were implemented using Jennic sensor nodes.
2. Simulation experiments: NS2 simulation model was used to test the efficiency for the approaches proposed in Chapters 4 and 7.

8.2.7 Outcome 7: Publish the proposed work

It was essential in this thesis to test the implemented work. The finding from the surveys described in this thesis was presented at an academic conference, namely the Convergence of Telecommunications Networking and Broadcasting (2007). A journal paper was also published by the International Journal of Advanced Mechatronic Systems (2008). One more conference paper was published at academic international conference, namely Automation and Computing. Another

paper was accepted for presentation at IECON09 conference of the IEEE Industrial Electronics Society (2009).

8.3 Potential Extensions of the Research

The findings of the thesis have certainly opened doors for more research work to be carried out in the area of tracking mobile targets through WSN. One of the most important developments and improvements that should be considered in future research is to improve the localisation accuracy of the proposed tracking system by using other localisation technologies, such as ultrasound. The proposed approaches in this thesis should be extended to be deployed in a larger area, which could include a large, multi-storey building. This is important to test the accuracy and efficiency of the proposed tracking system in a large area.

Future investigation could be done to extend the proposed power-efficient system to multiple-target scenarios, in addition to implementing the proposed approach on real sensor nodes. The future work includes implementing the proposed system in real sensor networks, and testing the efficiency of tracking multiple mobile targets through a WSN, while achieving low power-consumption.

One of the most important developments and improvements that should be added to a future fingerprinting approach proposed in Chapter 4, is to improve the autonomous segmentation process by adopting Artificial Intelligence, in addition to increasing localisation accuracy by focusing on other localisation methods

REFERENCES

-
- [1] Ahmad, U., Gavrilov, A., Nasir, U., Iqbal, M., Seong, J. C., and Sungyoung, L. “In-building Localization using Neural Networks”, *IEEE International Conference of Intelligent Systems*, Islamabad, Pakistan, March 2006.
- [2] Akyildiz, I.F., Weilian, Su., Sankarasubramaniam, Y., and Cayirci, E. “A survey on sensor networks”, *IEEE Communications Magazine*, August 2002.
- [3] Alhmiedat, T., and Yang, S. “A Survey: Localization and Tracking Mobile Targets through Wireless Sensor Network”, *PGNet International Conference*, ISBN: 1-9025-6016-7, 2007.
- [4] Alhmiedat, T., and Yang, S. “A Decentralised Low-power ZigBee-based Localization Approach”, *14th International Conference on Automation and Computing*, Brunel University, West London, UK, 2008a.
- [5] Alhmiedat, T., and Yang, S. “A ZigBee-based Mobile Tracking System through Wireless Sensor Networks”, *International Journal of Advanced Mechatroci Systems*, Vol. 1, No. 1, pp. 63-70, 2008b.

-
- [6] Alhmiedat, T., and Yang, S. "Tracking Multiple Mobile Targets Based on ZigBee Standard", *Proceedings of the 35th Annual Conference of the IEEE Industrial Electronics Society*, Porto, Portugal, November 2009.
- [7] Alippi, C., and Vanini, G. "A RSSI based and calibrated centralized localization technique for Wireless Sensor Networks", in *Proc. of IEEE International Conference on Pervasive Computing and Communications (PerCom)*, Pisa, Italy, pp. 301–305, March 2006.
- [8] Aslam, J., Butler, Z., Crespi, V., Cybenko, G., and Rus, D. "Tracking a Moving Object with a Binary Sensor Network", *International Conference on Embedded Networked Sensor Systems*, pp. 150-161, 2003.
- [9] Bahl, P., and Padmanabhan, V. N. "Radar: an in-building RF based user location and tracking system," in *Proceedings of 19th Annual Joint Conference of the IEEE Computer and Communications Societies (INFOCOM '00)*, Vol. 2, Tel Aviv, Israel, March, pp. 775-784, 2000.
- [10] Baronti, P., Pillai, P., Chook, V.W., Chessa, S., Gotta, A., and Hu, Y.F. "Wireless sensor networks: a survey on the state of the art and the 802.15.4 and ZigBee standards", *Elsevier Computer Communications* 30 (7), pp.1655–1695, 2007.
- [11] Battiti, R., Nhat, T. L., and Villani, A. "Location-aware computing: a neural network model for determining location in wireless LANs," *Tech. Rep. DIT-02-0083*, University of Trento, Trento, Italy, February 2002.
- [12] Benavoli, A., and Chisci, L. "Improved estimation for object localization via sensor networks", *Networking, Sensing and Control, IEEE International Conference*, pp. 302-306, 2007.

-
- [13] Blumenthal, J., Grossmann, R., Golatowski, F. and Timmermann, D. “Wighted centroid localization in ZigBee based sensor networks”, *Folien IEEE International Symposium on Intelligent Signal Processing, WISP*, Madrid, Spain, 2007.
- [14] Blumenthal, J., Reichenbach, F. and Timmermann, D. “Position estimation in ad-hoc wireless sensor networks with low complexity”, *Joint 2nd Workshop on Positioning, Navigation and Communication (WPNC 05) and 1st Ultra-Wideband Expert Talk*, pp.41–49, 2005.
- [15] Bulusu, N., Bychkovskiy, V., Estrin, D., and Heidemann, J. “Scalable, ad hoc deployable rf based localization”, *Grace Hopper Celebration of Women in Computing Conf*, Vancouver, British Columbia, Canada, 2002.
- [16] Bulusu, N., Heidemann, J., and Estrin, D. “Density Adaptive Algorithms for Beacon Placement in Wireless Sensor Networks”, *Proceedings 21st International Conference on Distributed Computing Systems*, pp. 98, 2001.
- [17] Bulusu, N., Heidemann, J., and Estrin, D. “GPS-less low-cost outdoor localization for very small devices”, *IEEE Personal Communications*, Vol. 7, pp. 28–34, 2000.
- [18] Ditzel, M., Lageweg, C., Janssen, J., and Theil, A. “Multi-target Data Aggregation and Tracking in Wireless Sensor Networks”. *Journal of Networks*, Vol. 3, No. 1, pp. 1-9, 2008.
- [19] Doherty, L., Pister, K. S. J., and El Ghaoui, L. “Convex Position Estimation in Wireless Sensor Networks,” *IEEE INFOCOM*, Vol .3, pp. 1655-1663, 2001.
- [20] El-Rabbany, A. “Introduction to GPS: the Global Positioning System”, *Boston, MA : Artech House*, 2002.

-
- [21] Ergen, S. C. "ZigBee/IEEE 802.15.4 Summary", Available Online:
<http://pages.cs.wisc.edu/~suman/courses/838/papers/zigbee.pdf>. 2004.
- [22] Galstyan, A., Krishnamachari, B., Lerman, K., and Patten, S. "Distributed Online Localization in Sensor Networks Using a Moving Target", *International Symposium on Information Processing in Sensor Networks*, Vol. 3, pp. 61-70, 2004.
- [23] Gupta, R., and Das, S. R. "Tracking Moving Targets in a Smart Sensor Network," *IEEE Veh. Technol. Conf.*, Vol. 5, pp. 3035-3039, 2003.
- [24] Hannikainen, M., Lavikko, T., Kukkala, P., and Hamalainen, T. "TUTWLAN—QoS supporting wireless network", *Telecommunication Systems—Modelling, Analysis, Design and Management*, pp. 297–333, 2003.
- [25] He, T., L. Gu, L. Luo, T. Yan, J. Stankovic, T. Abdelzaher, and S. Son. "An Overview of Data Aggregation Architecture for Real-time Tracking with Sensor Networks", *In Proc IEEE, RTAS*. pp. 55-66, 2006.
- [26] He, T., Stankovic, J. A., Huang, C., Abdelzaher, T., and Blum, B. M. "Range-Free Localization Schemes for Large Scale Sensor Networks," *Proceedings of the Annual International Conference on Mobile Computing and Networking, MOBICOM*, pp. 81-95, 2003.
- [27] He, T., Vicaire, P., Yan, T., Cao, Q., Zhou, G., Gu, L., Luo, L., Stoleru, R., Stankovic, J. A., and Abdelzaher, T. "Achieving Long-Term Surveillance in VigilNet", *In nfocom*, 2006.
- [28] Hightower, J., Boriello, G., and Want, R. "SpotON: An indoor3D Location Sensing Technology Based on RF Signal Strength", *University of Washington CSE Report 2000-02-02*, February 2000.

-
- [29] Hu, L. and Evans, D. "Localization for mobile sensor networks", In *Proceedings of the Tenth Annual International Conference on Mobile Computing and Networking (MOBICOM)*, Philadelphia, PA, September 2004.
- [30] Ilyas, M., and Mahhoub, I. "Handbook of Sensor Networks: Compact Wireless and Wired Sensing Systems" *CRC Press LLC*, 2005.
- [31] Jang, W., and Skibniewski, M. J. "Wireless Networks-Based Tracking and Monitoring on Project Sites of Construction Materials," *Journal of Civil Engineering and Management, VGTU, ISSN 1392-3730*, 2007.
- [32] Jung, B. and Sukhatme, G.S. "Tracking Multiple Moving Targets using a Camera and Laser Rangefinder", *Technical Report IRIS-01-397, Institute for Robotics and Intelligent Systems (IRIS)*, University of Southern California, 2001.
- [33] Karl, H., and Willig, A. "Protocols and Architectures for Wireless Sensor Networks", *John-Wiley*, New York, 2005.
- [34] Kolodziej, K. W., and Hjelm, J. "Local Positioning Systems: LBS Applications and Services", *CRC Press, Taylor & Francis Group*, 2006.
- [35] Krishnamachari, B. "Networking Wireless Sensors", *In Cambridge University Press*, 2005.
- [36] Kurth, D., Kantor, G., and Singth, S. "Experimental Results in Range Only Localization with radio", *IEEE/RSJ International Conference on Intelligent Robots and Systems*, Oct. 27-31, 1:974-979. ISBN: 0-7803-7860. INSPEC: 8380371. DOI: 10.11 09/ IROS. 2003.
- [37] Kushwaha, M., Volgyesi, P., Ledeczki, A., Molnar, K., Maroti, M., and Sallai, J. "Sensor node localization using mobile acoustic beacons," *2nd IEEE*

-
- International Conference on Mobile Ad-Hoc and Sensor Systems, MASS*, pp. 483-491, 2005.
- [38] Laasonen, K., Raento, M., and Toivonen, H. "Adaptive on-device location recognition", In *Proceedings of the Second International Conference on Pervasive Computing*, Springer-Verlag, pp. 287–304, 2004.
- [39] Labiod, H., Afifi, H., De Santis, C. "Wi-Fi, Bluetooth, ZigBee and WiMAX", 1st Edition, Springer, 2007.
- [40] Laitinen, H., Lahteenmaki, J., and Nordstrom, T. "Database correlation method for GSM location". In *Proceedings of the 53rd IEEE Vehicular Technology Conference*, Rhodes, Greece, May 2001.
- [41] Lamarca, A., Chawathe, Y., Consolvo, S., Hightower, J., Smith, I., Scott, J., Sohn, T., Howard, J., Hughes, J., Potter, F., Tabert, J., Powledge, P., Borriello, G., and Schilit, B. "Place Lab: Device Positioning Using Radio References in the Wild", *3rd Annual Conference on Pervasive Computing*, 2005.
- [42] Lazos, L., Poovendran, R., and Capkun, S. "ROPE: robust position estimation in wireless sensor networks," *Fourth International Symposium on Information Processing in Sensor Networks* (IEEE Cat. No. 05EX1086), pp. 31, 2005.
- [43] Lee, H., Wicke, M., Kusy, B., and Guibas, L. "Localization of mobile users using trajectory matching," in *ACM MELT*, 2008.
- [44] Lennvall, T., Svensson, S., and Hekland, F. "A comparison of wireless hART and zigbee for industrial applications", In *Proc. of 7th IEEE International Workshop on Factory Communication Systems, WFCS*, 2008.

-
- [45] Li, B., Dempster, A., Rizos, C., and Barnes, J. "Hybrid Method for Localization using WLAN", *Spatial Sciences Conference*, Melbourne, Australia, September 2005.
- [46] Li, B., Salter, J., Dempster, A. G., and Rizos, C. "Indoor Positioning Techniques Based on Wireless LAN", *Proceedings of AusWireless*, Sydney, Australia, March 2006.
- [47] Li, D., Wong, K., Hu, Y., Sayeed, A. "Detection, classification and tracking of targets in distributed sensor networks", *IEEE Signal Processing Magazine*, Vol. 19, No. 2, pp. 17-29, 2002.
- [48] Maeda, M., Ogawa, T., Machida, T., Kiyokawa, K., Takemura, H. "Indoor Localization and Navigation Using IR Markers for Augmented Reality", *Proc. 10th International Conference on Human-Computer Interaction (HCI International 2003)*, pp. 283-284, 2003.
- [49] Mallick, M. "Mobile and Wireless Design Essentials", 1st edition, *Wiley Publishing, Inc. Indianapolis, Indiana*, 2003.
- [50] Mechitov, K., Agha, G., Kwon, Y., and Sundresh, S. "Poster abstract: Cooperative tracking with binary-detection sensor networks," *SenSys'03: Proceedings of the First International Conference on Embedded Networked Sensor Systems*, pp. 332-333, 2003.
- [51] Nagpal, R., Shrobe, H., and Bachrach, J. "Organizing a global coordinate system from local information on an ad hoc sensor network," *Information Processing in Sensor Networks Proceedings*, Vol. 2634, pp. 333-348, 2003.
- [52] Niculescu, D., and Nath, B. "DV Based Positioning in Ad Hoc Networks," *In Journal of Telecommunication Systems*, Vol. 22, pp. 267-4, 2003.

-
- [53] Paschos, G. S., Vagenas, E. D., and Kotsopoulos, S. A. "Real-time localization for wireless sensor networks with multiple beacon transmissions," in *Proceedings of the 5th International Network Conference (INC '05)*, Island of Samos, Greece, July 2005.
- [54] Pattem, S., Poduri, S., and Krishnamachari, B. "Energy-quality tradeoffs for target tracking in wireless sensor networks", *In Proc. of 2nd Intl. Conf. on Information Processing in Sensor Networks (IPSN'03)*, 2003.
- [55] Priyantha, N. B., Chakraborty, A., and Balakrishnan, H. "The Cricket location-support system," *MobiCom 2000. Proceedings of the Sixth Annual International Conference on Mobile Computing and Networking*, pp. 43, 2000.
- [56] Ramanathan, P. "Location-centric approach for collaborative target detection, classification, and tracking in sensor networks," in *Proceedings of IEEE CAS Workshop on Wireless Communication and Networking*, September 2002.
- [57] Rappaport, T. S. "Wireless Communications: Principles and Practice", *Prentice-Hall Inc., New Jersey*, 1996.
- [58] Reichenbach, F., Blumenthal, J. and Timmermann, D. "Improved precision of coarse grained localization in wireless sensor networks", *9th DSD Conference*, Dubrovnik, Croatia, pp.630–637, 2006.
- [59] Reichenbach, F. and Timmermann, D. "Indoor Localization with low complexity in wireless sensor networks", *Proceeding of the IEEE (INDIN'06)*, pp.1018–1023, 2006.
- [60] Rodriguez, M., Pece, J. P., and Escudero, C. J. "In-building location using Bluetooth", *Technical report*, Universidade da Coruna, 2005.

-
- [61] Shang, Y., Fromherz, M. P. J., Ruml, W., and Zhang, Y. "Localization from mere connectivity," *Proceedings of the International Symposium on Mobile Ad Hoc Networking and Computing (MobiHoc)*, pp. 201-212, 2003.
- [62] Shareef, A., Zhu, Y., and Musavi, M. "Localization Using Neural Networks in Wireless Sensor Networks", *1st International Conference on Mobile Wireless MiddleWARE, Operating Systems, and Applications*, Innsbruck, Australia, 2008.
- [63] Shorey, R., Ananda, A., Chan, M., and Ooi, W. 'Mobile, Wireless, and Sensor Networks' *Canada, John Wiley & Sons, 2006*.
- [64] Small, J., Smaliagic, A., and Siewiorek, D. "Determining user Locations For Context Aware Computing Through the Use of a Wireless LAN Infrastructure", *Institute for Complex Engineered Systems, Carnegie Mellon University, Pittsburgh, PA 15213, USA, 2000*.
- [65] Sugano, M., Kawzoe, T., Ohta, Y., and Murata, M. "Indoor Localisation System using RSSI Measurement of Wireless Sensor Network based on ZigBee Standard," 2006.
- [66] Takahashi, S., Wong, J., Miyamae, M., Terada, T., Noma, H., Toriyama, T., Kogure, K., Nishio, S., "A ZigBee based Sensor Node for Tracking People's Locations", *ACM International Conference Proceeding Series*; Vol. 281, New York, USA, 2008.
- [67] Tanenbaum, S. A. "Computer Networks". 4th edition, Pearson Education, Inc. *Publishing as Prentice Hall PTR. Upper Saddle River, New Jersey 07458*, 2003.
- [68] Terwilliger, M., Gupta, A., Bhuse, V., Kamal, Z., and Salahuddin, M. "A localization system using wireless network sensors: a comparison of two

-
- techniques,” in *Proceedings of the 1st Workshop on Positioning, Navigation and Communication (WPNC '04)*, Hanover, Germany, March 2004.
- [69] Vaidyanathan, K., Sur, S., Narravula, S., and Sinha, P. “Data Aggregation Techniques in Sensor Networks”. *Technical Report OSU-CISRC-11/04-TR60*. Ohio State University, Columbus, 2004.
- [70] Want, R., Hopper, A., Falcao, V., and Gibbons, J. "The Active Badge Location System," *ACM Transactions on Information Systems : A Publication of the Association for Computing Machinery.*, Vol. 10, pp. 91-102, 1992.
- [71] Ward, A., Jones, A., and Hopper, A. "A new location technique for the active office," *IEEE Personal Communications*, Vol. 4, pp. 42-7, 1997.
- [72] Whitehouse, K., and Culler, D. "Macro-calibration in sensor/actuator networks," *Mobile Networks and Applications*, Vol. 8, pp. 463-472, 2003.
- [73] Xu, Y., Winter, J., and Lee, W. “Prediction based Strategies for Energy Saving in Target Tracking Sensor Networks,” *mdm, IEEE International Conference on Mobile Data Management (MDM'04)*, pp.346, 2004.