



This item was submitted to Loughborough's Institutional Repository (<https://dspace.lboro.ac.uk/>) by the author and is made available under the following Creative Commons Licence conditions.



CC creative commons
COMMONS DEED

Attribution-NonCommercial-NoDerivs 2.5

You are free:

- to copy, distribute, display, and perform the work

Under the following conditions:

BY: **Attribution.** You must attribute the work in the manner specified by the author or licensor.

Noncommercial. You may not use this work for commercial purposes.

No Derivative Works. You may not alter, transform, or build upon this work.

- For any reuse or distribution, you must make clear to others the license terms of this work.
- Any of these conditions can be waived if you get permission from the copyright holder.

Your fair use and other rights are in no way affected by the above.

This is a human-readable summary of the [Legal Code \(the full license\)](#).

[Disclaimer](#) 

For the full text of this licence, please go to:
<http://creativecommons.org/licenses/by-nc-nd/2.5/>

Modelling and Managing Project Complexity

Simon Austin¹, Andrew Newton², John Steele² and Paul Waskett²

1 Loughborough University, Leicestershire, LE11 3TU, UK e: s.a.austin@boro.ac.uk

2 AMEC Ltd, Stratford-on-Avon, CV37 9NJ, UK e: firstname.lastname@amec.com

Abstract

The Architecture, Engineering and Construction (AEC) industry, like many other, is increasingly aware of the need to improve efficiency and effectiveness to thrive in an increasingly competitive marketplace. A key discovery in their search for improvements is the benefits of repeatability in both processes and products. However, although the latter has seen significant advances, such as the adoption of pre-assembly and standardised components and systems, the industry has experienced far greater difficulties identifying ways of capturing, understanding, and replicating work processes. The identification and removal of waste from the process can only be achieved once the process has been captured. Their repeated use and development, combined with analysis with the Analytical Design Planning Technique, enable the improvement of work practices and culture in terms of integration, decision-making and reductions in re-work.

Introduction

To achieve anything more than a superficial understanding of the building design process, the complexities of the design activity have to be identified and represented in an appropriate manner. Graphical models are the ideal mechanism to achieve this. They allow the decomposition of complex systems into interrelated sub-elements that can be represented in the form of diagrams and text that are easier to assimilate. Modelling the information flows within a particular system or process can lead to a greater understanding of that process (Austin *et al.* 1996) and these models can then be applied by designers to help avoid the careless processing of incomplete or inaccurate information during the development of design solutions (Kraol 1983). This paper

describes the approaches taken by Loughborough University, AMEC and other industrial collaborators to modelling and analysing the building design process. These models have taken the form of a high-level description of the entire project process, as well as more detailed studies of each of the phases of which it is comprised, combined with their analysis with the Analytical Design Planning Technique (ADePT).

There are significant differences between the nature of the individual phases of the project process during progression from early stage design through to the later stages. These differences have influenced the choice of modelling notation to apply to each phase, with the models changing progressively from being frameworks for negotiation and agreement (with little focus on co-ordinated information flow) toward highly co-ordinated models representing structured information transfer (Figure 1) using sophisticated modelling notations. Nevertheless, the use of the project process as the basis for each of these models has ensured that they can be integrated and their interfaces aligned, thus identifying gaps and overlap.

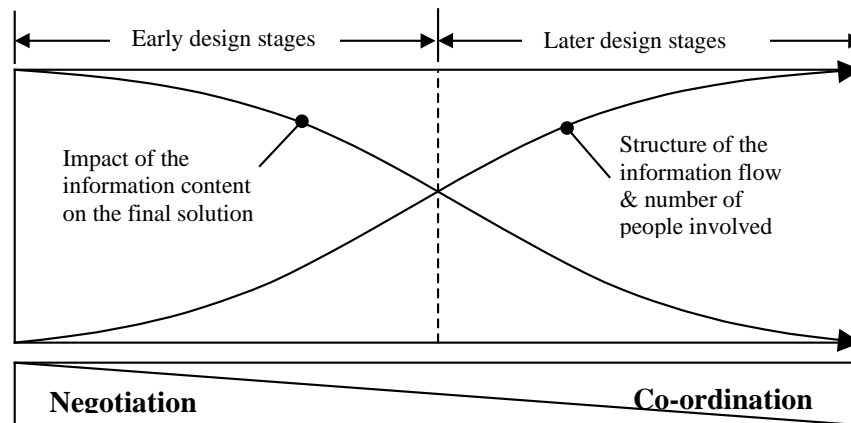

Figure 1 The Changing Nature Of The Project Process

The Project Process

The Generic Design and Construction *process protocol* (GDCPP), being developed by Salford and Loughborough Universities in conjunction with a number of industrial

collaborators, defines the design and construction process as four broad stages, which are then further categorised into ten discrete phases as shown in figure



2.

Figure 2 The Phases of a Construction Project Process defined by the GDCPP

The GDCPP was developed from a client perspective, with the main focus being the uneducated or one-off client (Kagioglou *et al.* 1998). However, the generic nature of the model ensures that it can be applied by a variety of client types on a variety of projects, and can be adapted to reflect the internal cultures and working practices of specific organisations, within the common structure of the generic framework. The GDCPP not only describes the physical stages of the process, but also addresses its management. This is an integral component in achieving project success (Pugh 1986) and the Protocol defines eight key management areas (Development, Project, Resource, Design, Production, Facilities, Health & safety, statutory and legal, and Process) involved at each phase. The Protocol is being defined to an increasingly detailed level, with 270 level-two activities within the 10 phases (plus standard start-up, on-going and end-of-phase activities) now identified.

The overriding aim of the map itself is to improve the collaboration between companies in the traditionally fragmented construction industry. However, it also attempts to

provide a standard framework for clients around which they may enhance the effectiveness of their work (Sheath *et al.* 1996). It can also contribute to culture change by improving communication and process management between the fragmented groups within the construction industry. In particular, it provides a common language by which all parties can locate themselves and their processes within the project organisation as a whole. It has already been adopted by several major UK construction organisations as a vehicle for investigating their processes or addressing the specific requirements of large projects.

The remainder of this paper outlines the development of the models that represent some of the design stages of the GDCPP and how the processes can be improved by application of ADePT.

The Early Design Stages – Concept And Scheme

The early phases of the design process have received relatively little attention, even though decisions made during this period have the most far-reaching effects on the remainder of the project. It is recognised that early stage design often fails to deliver outputs that meet the expectations of clients. These failings, which typically become manifest in the need for redesign and poor quality cost advice are, primarily, the result of: i) poor communication between stakeholders; ii) ineffective collaboration; iii) little understanding of the complexity of the interdisciplinary nature of design; and iv) weak and unconsidered decision-making. The existing design procedures that are available to the interdisciplinary design team tend to be lists of deliverables rather than guidance documents providing design teams with an outline of what to do and by what method it should be achieved. In this respect, there seems to be an over-reliance on the experience of designers to 'know how to design'. At present, no consistent approach to early stage design exists within the building industry (Austin *et al.* 2001a). Two research projects involving Loughborough University and AMEC have addressed this issue through the development and analysis of generic models of the early stage design process, with each using very different approaches to capturing and representing the processes.

In the Mapping Conceptual Design project, undertaken in collaboration with the University of Cambridge, a generic framework was developed, comprising five phases and twelve activities, for use as a guiding principle rather than a structured plan of work. Figure 3 shows the framework, which was refined in workshops and subsequently developed into a generic process model that clustered the design activities in relation to the manner in which they were commonly addressed (Macmillan *et al.* 2001). Additionally, this model accounts for the design team's need to focus on, and maintain, team performance. In this respect, successful collaborative conceptual design is much more dependent upon the level of negotiation and agreement than the formal co-ordination and transfer of information between team members (Figure 1).

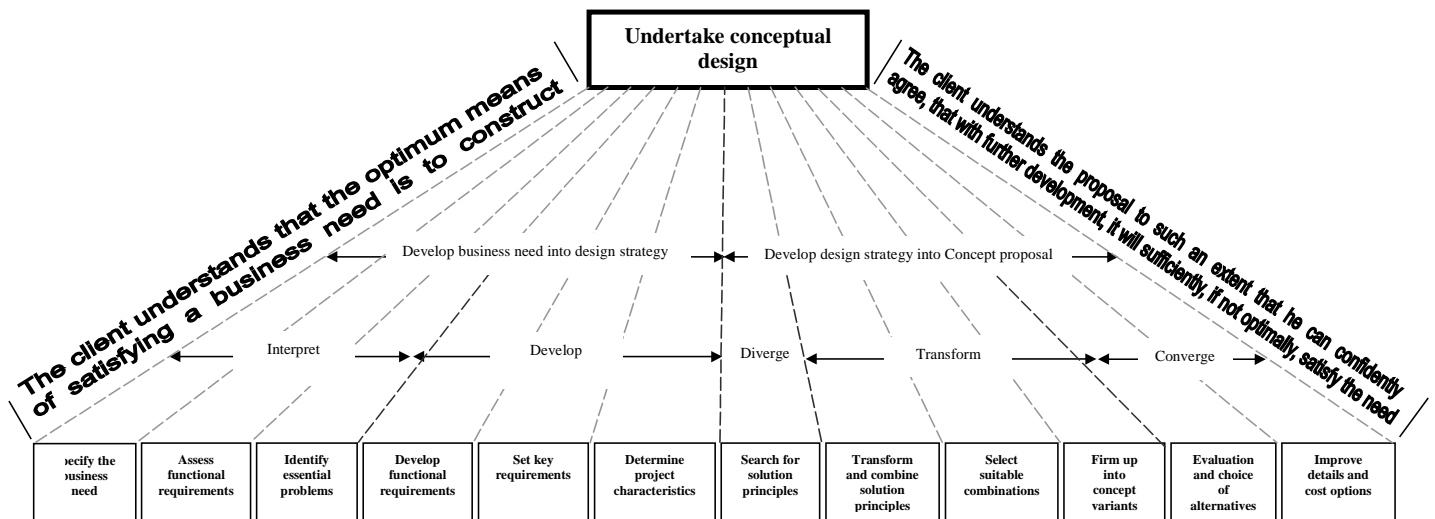

Figure 3 An Overview of the Conceptual Design Framework

The scheme design stage was modelled in a different manner owing to the need for improved co-ordination as the project process advances. It is clear that both the concept and scheme design stages are primarily concerned with information gathering and decision-making to enable the team to propose a solution to the stakeholders needs. However, as the project progresses into scheme design the cost of the developing solution must be established and the risks involved in its delivery assessed. Thus, this research developed a model of the scheme design stage centred on decision-making and

the resulting transfer of design and cost information between the project team (including the client) as an integrated process (Baldwin *et al.* 1997). This was initiated by defining the high-level activities undertaken during the scheme design period and sub-dividing these into their component parts. This process was repeated a number of times until the lowest level design tasks were identified for each discipline. In this way a four-level hierarchy of activities was produced (an example developed for detailed design is shown in figure 4). In order to develop the process model from this work breakdown structure, information flows between the tasks were captured and represented using a structured modelling technique, IDEF0. This notation, which has been used primarily in the manufacturing and business process re-engineering domains, uses boxes to define activities and processes with arrows denoting information transfer between them. The notation was modified slightly (and renamed IDEF0v) to enable a differentiation between information transfer within and across disciplines to be represented, thus enabling the building design process to be captured in a more appropriate and useful manner. The resulting model, which comprises some 150 tasks and 1500 information flows, represents a network of tasks connected by the flow of information between them.

The Late Design Stages – Detailed Design and Production Information

The transition from scheme design into detail design brings with it a shift from negotiation and agreement being the principle driver for the design process to the co-ordination of the design activity becoming of greater significance to project success. This shift in focus is commonly recognised within the industry and reinforces the importance of effective design management in facilitating a co-ordinated design, within budget, and ensuring the smooth running of projects. To deliver improved planning of projects a Loughborough University-based research project developed the ADePT methodology (see below), a component of which involved the construction of a model of the detailed design process. As with the scheme design model discussed previously, the detailed design model was derived by first developing a hierarchical breakdown of the activities involved in the design process (Figure 4) before identifying the information flows between those activities to generate the model (Figure 5). However, this model differs from the scheme model in that it is global in nature and is not based on a single project

type. The tasks and information flows contained within the detailed model can be tailored to represent the basis of any project, with only minor alterations being required to generate the project specific version.

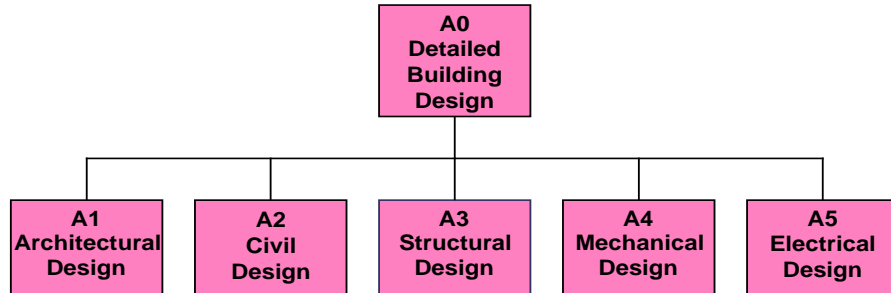

Figure 4 The Highest Level of the Discipline-Based Work Breakdown Structure

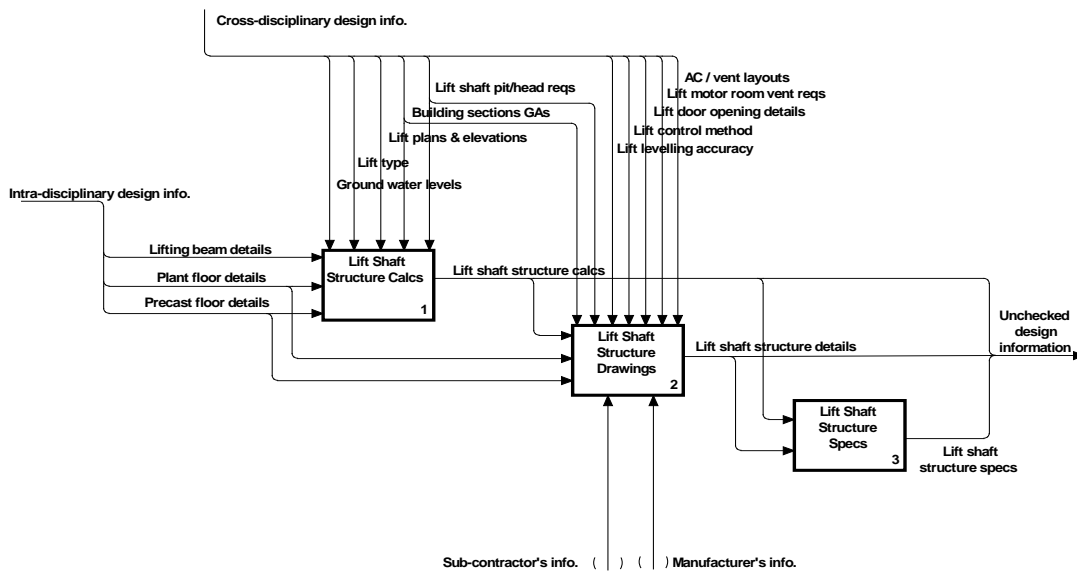

Figure 5 An IDEF0v Diagram from the Detailed Design Model

This global model, which was also developed using the IDEF0v notation, is structured in a manner that reflects the discipline-based way in which industry currently works (representing architectural, civil and structural engineering, and mechanical and electrical engineering activities). The model comprises some 150 diagrams containing 580 design tasks and 4600 information requirements (Austin *et al.* 1999). In applications

to date, the global model has been found to contain approximately 90% of the tasks required to produce project specific models. This figure will increase as the model evolves through further application on a wider range of projects.

The effectiveness of this model, and the opportunities for improved planning afforded by the ADePT methodology, has also driven the development of models of the production information stage of the project process. This work, which has been undertaken as part of the Integrated Collaborative Design (ICD) research project, has involved both modelling the exchange of information between the design team and suppliers undertaking the fabrication activities, and identifying how the process model and associated analytical techniques (including ADePT) can be used to improve decision-making and activity scheduling.

Using the same approach to model development described previously, the exchange of information between the design team and suppliers undertaking the fabrication and construction activities has been modelled (Hammond *et al.* 2000). The models have captured the metamorphosis of the intangible design information into tangible construction materials (Figure 6).

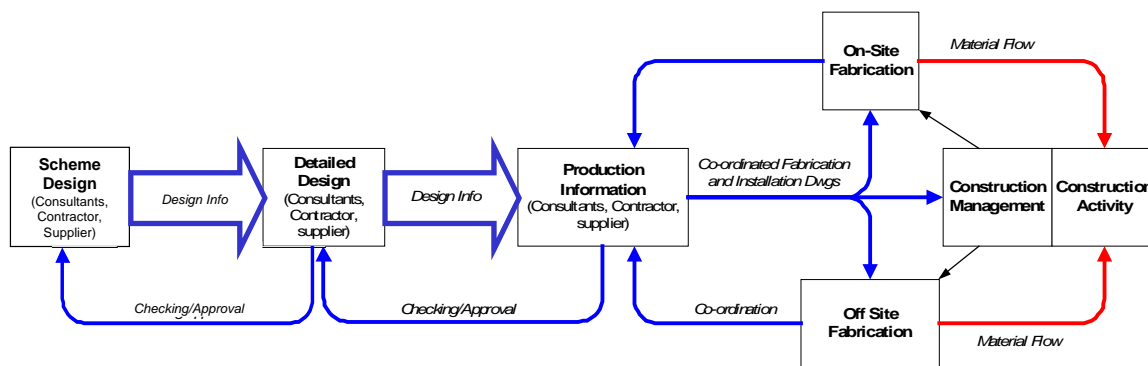

Figure 6 A Model of the Changing Nature (from Information to Material) of Exchanges

These models have enabled the interfaces between consultant-based design and supplier-based design to be aligned, allowing the skills and expertise of each to be dovetailed, and potential duplications and deficits in the design process to be identified and managed. As such, the models have facilitated both the optimisation of the design process to a level beyond that which may currently be achievable, and the removal of

unnecessary projects costs in terms of: reduced prime cost to the client; higher fee profit for designers; and reduced effort and abortive work.

The Analytical Design Planning Technique (ADePT)

Introduction

Effective design planning requires the application of techniques that can account for the complexity and non-linearity of the design process. Traditionally, owing to the successful application of planning techniques such as the Critical Path Method (CPM) in construction, the design process has been planned in a similar manner. Unfortunately, the iterative nature of the building design process makes the application of such techniques wholly inappropriate. The ADePT methodology, which was developed in response to this need, provides a powerful, yet simple, means of understanding the interdependencies between tasks in the design process.

ADePT can take process models, optimise them and then be used to manage the resulting complexity. The methodology, shown in figure 7, comprises three stages. Firstly, a model of the building design process of a project is produced, in both graphical and database format, showing the relationship between design activities based on the flow of information in the process. Secondly, dependency structure matrix (DSM) analysis identifies an optimum sequence of activities based upon the dependency and availability of design information as defined in the design process model. Finally, the matrix analysis is linked to a planning and scheduling package so that design programmes can be produced when resources and duration of tasks are allocated to the re-sequenced activity schedule.

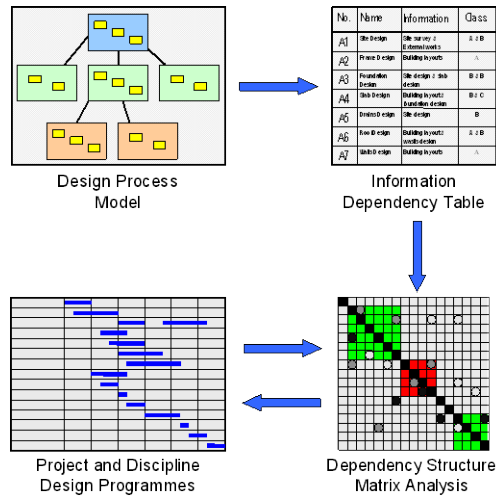

Figure 7 An Overview of the Analytical Design Planning Technique

An example of a Dependency Structure Matrix (DSM), the second part of ADePT, is shown in Figure 8.

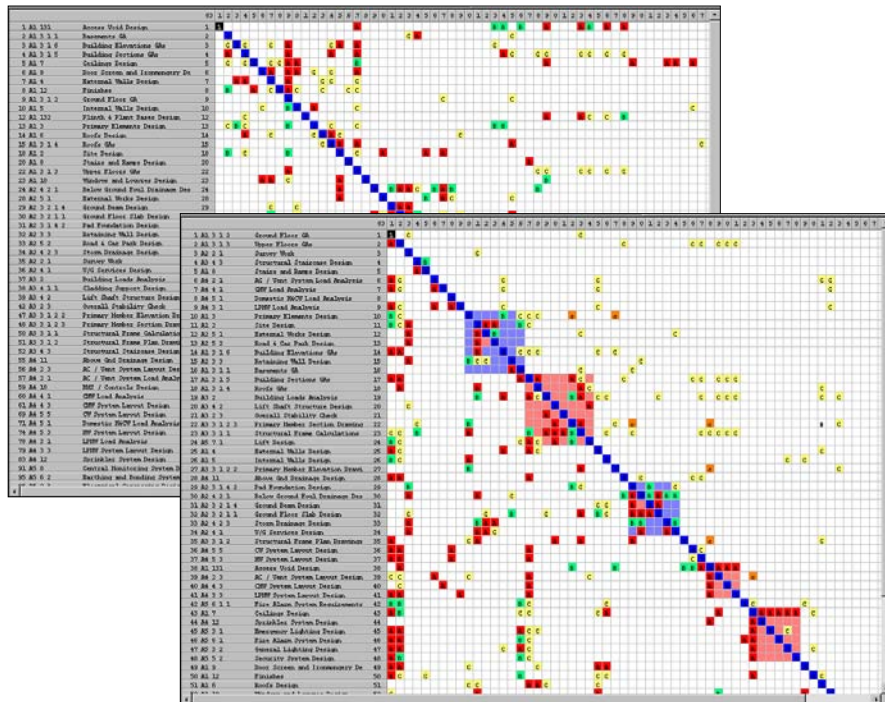

Figure 8 A Simple Example of Dependency Structure Matrix Analysis

In the matrix tasks are initially listed alphabetically in the rows of the matrix. The order is mirrored in the columns. A mark in the matrix represents a dependency of the task in the row upon the task in the column, the dependencies being weighted on a three point scale (A, B, C) on the basis of the strength of dependency. If design is undertaken in the order on the matrix from top-left to bottom-right, there is a considerable need for iteration within the process. Figure 8 also shows the matrix following analysis to determine the optimal sequence of tasks such that iteration is reduced to a minimum. It can be seen that the number of critical marks above the diagonal is greatly reduced, as is the scale of iteration within the process which is indicated by the shaded blocks.

ADePT challenges designers to place greater emphasis on understanding and analysing the process of design. More specifically it offers a means of illustrating to the client, designers and building contractors, the importance of timely release of information, appropriate quality of information and fixing of design, and the resulting implications for cost, design flexibility and risk. It also ensures that the appropriate information is exchanged between members of the design team and that the problem of information overload is minimised. Variations can be assessed rapidly, allowing objective decisions to be made about the resulting changes to project duration, resource levels and engineering economics (Austin *et al.* 2000). Some of the practical application of ADePT and associated benefits are described below.

Improving the Design Process

The integration of stages of a project and team members within each stage changes to the ways a project is managed and team members behave and interact. Where the design team may be co-located or expected to develop the design through a series of workshops, this suggests a change to the way complex co-ordination is approached. The blocks of interdependent design activity require a concerted management effort, rigorous review strategy and a strong link to the client's decision-making and approval processes. They also highlight where a concurrent, collaborative working strategy is appropriate for the team members, who must liaise closely in all decisions, understand each others' design requirements and constraints, and have confidence in each others' commitment to the achievement of a common aim.

The graphical nature of a matrix allows the impact of changes and variations to be envisaged quickly and easily, by moving tasks within the matrix (usually down the order) to simulate them being undertaken following the change. The tasks that must then be re-examined are clearly indicated by the matrix. This is a particularly useful feature where the work of one design discipline is affected by the decisions of another, or where the design in general is delayed by the decisions of the client.

A further area is the co-ordination of work between the design phases, to ensuring that adequate design development is undertaken in each discipline to provide the required cost certainty and confidence to the client. The Generic Design and Construction *process protocol* (GDCPP) should provide a means of identifying the timely introduction of suppliers into the design process, a benefit that is beginning to be seen during the latter stages of a design project from the implementation of ADePT.

Integrating Design and Construction

Scheduling the design process with ADePT identifies the optimal sequence of tasks to satisfy the development of a design solution. In practice, it is unlikely that this sequence will be realistic because of the production constraints put on the process by the need to deliver a project in a short a time-scale as possible. However, comparison with a view of the ideal construction sequence (which is relatively easy to determine with the use of readily available project planning tools), provides a good starting point to integrate design within the wider project process (Figure 9).

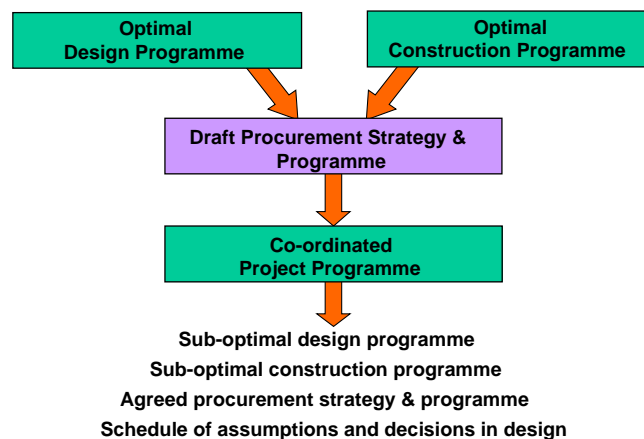

Figure 9 A Schematic of the Integration of Design and Construction Processes

This integration is not straight-forward, as the two processes do not fit together comfortably. In order that they are integrated, the constraints that each process puts on the other must be considered. The schedule is produced through the analysis of the constraints on the design process: the cost of fixing or estimating information within the design can be compared against the risk of not doing so, thereby allowing the engineering economics in design to be assessed and logged in a risk register. As such, ADePT can act as a tool to compliment risk management. It identifies areas of design where risks are present, illustrates the scale of risk in the design process itself (in a similar way to evaluating the effects of change) and contributes to the development of a legacy risk register.

Having established an approach to undertaking the design and an agreed procurement strategy, each contract can be examined to determine who in the supply chain is best placed to undertake the design. The matrix analysis stage of ADePT also provides a means of assessing the impact of each package of work upon the others, and the need for co-ordination between them. This is in accordance with the UK construction industry's call for integration within the project supply chain, and the application of ADePT to the fabrication design stage (production information) of a project has been undertaken through the Integrated Collaborative Design project (Austin *et al* 2001b). This project is determining strategies for integrating contractors and suppliers into the consultants' design process in a manner that is both timely and that allows the design co-ordination and contracts to be effectively managed. The key to this approach is that participants should be introduced into the project early enough to allow their design to be co-ordinated with other parts of the project, and as late as possible such that their design is not constrained by decisions made by the consultant.

Challenges and Benefits

Through the development and application of design process models the design team can make more considered decisions, as they are aware of all factors relating to the design task at hand and the other activities it influences. This enables risks to be identified and transferred into the risk management process, thus allowing effective control measures to be introduced. In analysing the process models as part of ADePT, the tasks within the

model can be programmed optimally to deliver improved efficiency in the design production process, savings on design fee expenditure, and benefits in the form of improved co-ordination with construction (resulting in improvements in cost, programme performance, and predictability).

The use of the process models within ADePT also improves project team performance by fostering trust and encouraging collaborative working. In order to improve and maintain both efficiency and effectiveness integrated teams must achieve a collaborative, continuous-improvement culture of 'right on time, first time' over the course of a number of projects. Designers and constructors must improve their understanding of the process, in conjunction with their roles and responsibilities within it, if this is to be achieved. Capturing and representing these complex processes in the form of models, and analysing them using the ADePT methodology provides a mechanism to achieve this, in addition to improving the effectiveness and efficiency of the design planning process. The testing and application of ADePT has demonstrated that it is a viable technique with which to plan, manage and control design work and aid integration of the design and construction processes. The technique is being further developed and made available to practising planners, project managers and designers through an Internet-provided software application called PlanWeaver.

Through the use of process modelling, DSM analysis and the production of design programmes, the planning of complex design projects can be approached in a more systematic, informed, and efficient manner compared with current practice.

References

Austin S, Baldwin A, Newton A 1996. A Data Flow Model To Plan And Manage The Building Design Process. *Journal of Engineering Design* - Vol. 7, No. 1: 3-25.

Austin S, Steele J, Macmillan S, Kirby P and Spence R. 2001a. Mapping the conceptual design activity of interdisciplinary teams. *Design Studies*, Vol. 22, No. 3, April: 211-232.

Austin S, Baldwin A, Hammond J, Murray M, Root D, Thomson D and Thorpe A. 2001b. *Design Chains – a Handbook for Integrated Collaborative Design*. In press, Thomas Telford, London.

Austin S, Baldwin A, Li, B & Waskett P 1999. Analytical Design Planning Technique: A Model of the Detailed Building Design Process. *Design Studies*, Vol. 20, Issue 3, April: 279 - 296.

Austin S, Baldwin A, Li, B & Waskett P 2000. Integrating Design In The Project Process. *Proceedings of the ICE, Civil Engineering, November*. 177-182.

Baldwin A, Austin S, Pendlebury M. 1997. The Interface Of Early Stage Design And Cost Advice In The Building Design Process. In *Proc of the 13th ARCOM Annual Conference, Cambridge*, Vol.2: 395-404.

Hammond J, Choo H J, Tommelien I, Austin S, Ballard G. 2000. Integrating Design Planning, Scheduling And Control With Deplan, *Proceedings 8th Annual IGLC Conference*, Brighton, July 2000.

Kagioglou M, Cooper R, Aouad G, Hinks J, Sexton M, Sheath DM. 1998. *A Generic Guide To The Design And Construction Process Protocol*. University of Salford, UK.

Kraol L 1983. Implementation Experiences Of Design Applications. In *Proceedings Of The International Conference On Computers In Architecture '83*. On-line conferences Ltd: 65-80.

Macmillan S, Steele J, Austin S, Kirby P and Spence R 2001. Development of a generic conceptual design framework. *Design Studies*, Vol. 22, No. 2, March: 169-191.

Pugh S. 1986. Design Activity Models – World-wide Emergence And Convergence. *Design Studies*, Vol.7, No.3: 167-173.

Sheath D M, Woolley H, Cooper R, Hinks J and Aouad G. 1996. A Process For Change - The Development Of A Generic Design And Construction Process Protocol For The U.K Construction Industry. In *CIT'96*. Sydney, Australia.