



This item was submitted to Loughborough's Institutional Repository (<https://dspace.lboro.ac.uk/>) by the author and is made available under the following Creative Commons Licence conditions.



CC creative commons
COMMONS DEED

Attribution-NonCommercial-NoDerivs 2.5

You are free:

- to copy, distribute, display, and perform the work

Under the following conditions:

BY: **Attribution.** You must attribute the work in the manner specified by the author or licensor.

Noncommercial. You may not use this work for commercial purposes.

No Derivative Works. You may not alter, transform, or build upon this work.

- For any reuse or distribution, you must make clear to others the license terms of this work.
- Any of these conditions can be waived if you get permission from the copyright holder.

Your fair use and other rights are in no way affected by the above.

This is a human-readable summary of the [Legal Code \(the full license\)](#).

[Disclaimer](#) 

For the full text of this licence, please go to:
<http://creativecommons.org/licenses/by-nc-nd/2.5/>

NT-87-24-3

THE FORMULATION, CHARACTERISTICS, AND SOLUTION OF HVAC SYSTEM OPTIMIZED DESIGN PROBLEMS

J.A. Wright, Ph.D. V.I. Hanby, Ph.D.

ABSTRACT

Heating, ventilating, and air-conditioning (HVAC) system design can be markedly improved through the application of numerical optimization procedures within the design process. This paper describes a procedure for the formulation and solution of HVAC system optimization problems that has been implemented in a library of computer programs. Consideration is given to the interaction between the simulation of the systems performance and the optimized design objective and constraint functions. Conclusions are drawn from example applications, and suggestions are made for the further development of a solution algorithm.

INTRODUCTION

At an early stage in the design process, the HVAC engineer must consider alternative solutions to the design problem. Selection of the most appropriate system is often based upon the engineers experience and intuition, there being insufficient resources available to thoroughly explore each alternative design. Detailed design of the chosen system continues with the size of the components selected to meet the peak loads on the system and to perform efficiently while operating under arbitrarily chosen conditions (such as flow and return temperatures). This process leads to a workable design solution (Stoecker 1971) which:

1. Meets the requirements of the purpose of the system (such as providing the required amount of heating or cooling).
2. Will have satisfactory life and maintenance costs.
3. Abides by all constraints (such as size, temperature, and noise).

Introduction of system simulation techniques increased the exploratory power available to the engineer by allowing him to investigate the performance of alternative designs for a wide range of operating conditions. In early simulation procedures, the choice of system modeled was limited to those available on a standard menu of systems and control strategies. Flexibility in modeling nonstandard and innovative designs was achieved later with the introduction of component based simulation procedures in which the system configuration is related to the engineer's schematic diagram and is compiled using a menu of components (Murray 1984).

For a comparison of different systems to be valid, the engineer must ensure that the design parameters (equipment selections and controller set points) are such that the system is operating at its "best." Although system simulation techniques have increased the exploratory power available, the onus is still on the engineer to select appropriate design parameters, which, when performed manually, is both haphazard and time-consuming. The approach described in this paper is one in which a data base of component selections and controller set points is automatically searched to find the combination of parameter values that gives the optimum performance of the system as defined by a specified criterion (such as

J.A. Wright, Lecturer, Department of Architecture and Building Engineering, The University of Liverpool, Merseyside, England, and V. I. Hanby, Lecturer, Department of Civil Engineering, Loughborough University of Technology, Leicestershire, England.

operating or life-cycle cost).

The Optimized Design of HVAC Systems

Selection of the optimum HVAC system is based on both qualitative and quantitative parameters. To ensure a true comparison of systems, the quantitative parameters must represent the optimum selection of the system components and control settings. The procedure for the optimized design of HVAC systems has three elements (Figure 1):

1. The "expert," whether the designer or expert system software, identifies the possible system configurations based on an outline of the application.
2. For each system, the value of the design parameters is optimized for a given criterion.
3. The criteria values of each system are used as the quantitative parameters in the assessment of each system's performance, thus enabling the selection of the optimum system.

The ease with which an optimization procedure for a given system configuration can be developed is limited by the physical connections between the components and by the product ranges available (Figure 2). For each component, there are two sources of product range; first, the components could be supplied by one of several manufacturers and, second within a given manufacturer's range, there will be geometric and variable differences that further divide each range into different products.

For a given combination of product ranges, there will be a local optimum choice of component sizes and control settings. Changing the product range for one component can influence the optimum size of other components in the system, indicating that there are two levels of optimization in sizing the system; finding the optimum combination of product ranges, and, for that combination, finding the optimum size of the components. Numerical optimization procedures require numerically identifiable parameters for which to search. It is impracticable to assign meaningful numerical values to product ranges when they are distinguished merely by supply from different manufacturers. This limits the search for the optimum combination of product ranges to an exhaustive one (Figure 3). However, the sizes of the components can be defined numerically, allowing the optimum selection of components for a given combination of product ranges to be performed by numerical optimization techniques.

THE FORMULATION OF THE OPTIMIZATION PROBLEM

The optimum selection of HVAC system components and control settings can be described according to the elements of a numerical optimization problem:

1. The problem variables; those variables that are searched by the optimization algorithm in order to minimize the value of the objective function.
2. The design constraints; functions that limit the solution to a practicable one.
3. The objective function; a criterion (such as first cost) that is to be minimized.

The formulation of some constraints and objective functions, in HVAC design problems, is particularly dependant upon the procedure used to simulate the performance of the system, and, therefore, the type and format of the simulation procedure must be considered when developing an optimization procedure.

HVAC System Problem Variables

The problem or design variables in HVAC system optimization studies are the parameters normally used to describe the selection of HVAC components. These represent the physical size and operating point of the component or may be associated with the capacity of the component. For example, the parameters used to specify the selection of centrifugal fans are impeller diameter and running speed, the impeller diameter representing the physical size of the fan and running speed its operating point. Conversely, the manufacturers' catalog numbers used to identify the selection of package chillers are more often related to the peak

duty of the chiller than its physical dimensions. Such catalog numbers can form suitable design variables with which to size package components, as they are an indication of both physical size and operating point of the component. A further group of problem variables are those that dictate the operating point of the system and are generally represented by the controller set points.

HVAC System Design Constraints

The most important of the HVAC system design constraints is that the optimum solution must be one in which all components operate within their design limits under both extreme and peak load conditions. Other design constraints arise from Codes of Practice, restrictions on configuration and on the size of components and fluid variable values. The general category of these constraints is of non linear functions in the form of equality, inequality, or range constraints. For example:

An equality constraint: The water flow and return connections of a heating coil can be specified to be on the same side of the coil. This requires an even number of tubes per circuit, giving the sparse equality constraint:

$$\text{fractional part of } (\text{tubes} / (2 \text{ circuits})) = 0$$

An inequality constraint: The limiting values of fluid velocities can be expressed as smooth nonlinear inequality constraints:

$$\text{water velocity} \leq 5.9 \text{ ft/s } (1.8 \text{ m/s})$$

A range constraint: The number of water tubes in a cooling coil must always be greater than or equal to the number of water circuits:

$$0 \leq (\text{circuits} - \text{tubes}) / (1 - \text{tubes}) \leq 1$$

HVAC System Design Objective Functions

The objective functions used in HVAC system design are the criteria used by design engineers to appraise and compare alternative design solutions. Those implemented in this research are:

1. Net energy consumption of the system
2. Primary energy consumption of the system
3. Capital cost of the system
4. Annual operating cost of the system
5. Net present value of the system
6. Payback period of the system

System Simulation and Optimized Design

A system simulation procedure is central to the development of HVAC system optimized design software, as the results of the simulation are used to predict the energy consumption of the system and to compute values of the constraint functions. The attributes required of a simulation procedure are:

1. The procedure must be a performance simulation (i.e., find the operating point of the system), so that the results can be used in evaluating the constraint functions as well as in predicting the system's energy consumption.
2. The procedure should be component-based to maintain flexibility in defining alternative system configurations and to promote the development of component performance, energy, cost, and constraint models.

It is feasible that an optimization procedure could be developed to operate with any simulation procedure having the above attributes, providing that the appropriate interfacing protocol could be developed. However, an area in which it is difficult to generalize is the formulation of a constraint function that represents the performance of one or more components outside its normal range of operation, since in this region the results are meaningless and often lead to failure of the simulation. Formulation of such a constraint, therefore, is dependent upon being able to interpret the results that are available on failure of the simulation.

The characteristic of the simulation procedure that most affects the validity of the constraint and objective functions is the way in which the performance of the system is simulated over a range of climatic and zone loads. The approach adopted in this research is to drive the simulation through a profile of loads for up to 25 time periods.

The validity of any constraint value influenced by the system's performance will depend on the degree to which the load profile represents the real load conditions. If the complete range of conditions under which the system is expected to perform are not included in the load profile, then, when these conditions are encountered in practice, some of the constraints may be violated. This is particularly important with respect to the component-undersizing constraint, as many components have to cope with both minimum and maximum loads. Further, extreme load conditions perhaps not normally used in the selection of components can prove invaluable if included in a load profile, as they improve the reliability of the undersized component constraint. For example, the selection of a cooling coil is normally based upon the peak cooling load, but if the conditions of extreme humidity often encountered early in the morning are not included in the load profile, then the selected cooling coil may not be able to cope with the dehumidification load imposed.

A load profile of several time periods provides a convenient means of integrating the system's energy consumption. However, as for the constraint functions, the range of conditions represented by the profile can influence the validity of this and other objective functions. The least obvious parameters affected are costs. Often components are assembled from primary and ancillary items such as a fan and its drive motor. Selection of the ancillary item is dependent upon the peak load on the item and, therefore, the calculated capital cost value of the complete assembly can only be ensured if the peak loads are included in the profile. Similarly, in the U.K., fuel tariffs are often related not only to usage but also peak demand. Finally, the component maintenance cost calculations adopted in this research are related to the peak load on specified items of plant (Milbank et al. 1971), again emphasizing the need to model peak loads.

COMPONENT MODELS

The central building blocks of the optimization procedure implemented in this research are the component models. Each component model is required to have the following characteristics: a performance model in which all the required operating characteristics of the component are reproduced, an energy model to enable the energy consumption of the component to be assigned to the related objective functions, a cost model including capital and maintenance cost, and, lastly, a constraint model to define the practicable region in which the component may operate (Hanby and Wright 1986).

Component Performance Models

Component performance models must reproduce the operating characteristics of the component as predicted by the manufacturer. To this end, the most widely available and applicable type of model is the steady-state, lumped parameter, input-output model, as it is rare for manufacturers to test the dynamic performance of components. The steady-state performance models implemented in this work have been written in terms of the system variables (temperature, mass flow rate, pressure, etc.) which means that derived quantities such as power consumption do not appear as terms in the equations. The equations are written in residual form with all the terms appearing on one side of the expression leaving a vector of residuals, \underline{f} , which has a value of zero at the solution. For example, if the pressure drop across a fitting is given by

$$P_i - P_o = k \frac{m^2}{\rho A^2}$$

then this would be cast as

$$f(l) = (k m^2 / \rho A^2 2) - (P_i - P_o)$$

where

P_i = pressure at inlet

P_o = pressure at outlet

k = pressure loss coefficient

m = mass flow rate

ρ = density

A = duct cross-sectional area at inlet

$f(l)$ = residual

Component Energy Models

Component energy models are formulated from three sources of energy flux; direct terms, ancillary terms, and extraneous terms. Direct terms represent the energy flux that can be calculated without reference to any other component, such as, the heat supplied from a heating coil. Ancillary energy terms arise where simplified component models are used. In a heat recovery wheel model, the wheel and its drive motor could be modeled as two separate components, each one of which would provide a direct term. However, it is more compact to model the complete assembly in an integral fashion and in this case the power consumption of the motor becomes an ancillary energy term. In order that subsystems can be modeled, extraneous energy terms are introduced to represent the direct energy flux of components not explicitly included in the system modeled. For example, in a problem in which the fans are omitted, the energy consumption of the fans can be approximated from the pressure losses across the other components in the system, this loss formulated from extraneous energy terms. However, the accuracy to which extraneous terms represent the energy consumption of implicit components is limited as the efficiency of this component is not always included in the formulation.

Component Cost Models

Development of rigorous component capital cost functions, which are applicable to a wide range of manufacturers' data, has proved difficult due to a lack of available data and the diverse way in which different manufacturers present their data. The response to this has been to develop a general strategy for data storage. Data can be stored for a combination of polynomial curve fit coefficients and data constants representing the manufacturers' tabulated data.

Component Constraint Models

The difficulty in forming rigorous mathematical component undersizing constraints has led to a procedure which simply rejects infeasible solutions, the constraints providing no more than a check on feasibility. This has allowed the component constraint functions to be written in the general form of range constraints:

$$lbi \leq ci(x) \leq ubi$$

where

lbi = constraints lower bound

ubi = constraints upper bound

$ci(x)$ = constraint

This, together with simple bounds on the variables, has proved adequate for most cons-

straints, although they may not always be defined in the most rigorous fashion.

PROBLEM DEFINITION AND EXECUTION

Computer software has been developed to formulate and solve HVAC system optimization problems (Wright 1986). Its operation is in two phases, the problem definition phase and the solution execution phase.

Problem Definition

Definition of the complete optimization problem is in two parts. First, the system configuration is compiled by selecting components from a menu and defining the links between the components by labeling the system variables (mass flow rates, temperatures, etc.) of each component with numbers that are used to formulate a connectivity matrix. Some of the system variables can be taken outside the set of variables in the simulation (declared exogenous) and given fixed values or driven by the load profile. Exogenous variables (such as chilled water temperature and control set points) can also be defined as problem variables in the optimization problem.

Formal definition of the optimization problem, which is held in a set of describing matrices, begins with the identification of the problem variables. The matching dimensions of adjacent components are identified and the system operating variables, which will influence the optimum solution, selected. Appropriate product ranges and the range of values for the system variables are chosen. Completion of the problem definition is achieved with the selection of the design constraints and an objective function. Objective functions for which energy consumption is a parameter require the definition of a system energy model formulated from appropriate component energy terms. Fuel costs and interest rates are assigned for use with economics-related objective functions.

Execution

Execution begins with the selection of an initial set of problem variable values (products and operating variable values) which combine to provide a system that operates within all the specified constraints (the initial feasible point). From this point, the optimization algorithm successively changes the problem variable values in such a way as to reduce the value of the objective function while satisfying all constraints. For each change in value of the problem variables, the performance of the system is simulated. This is necessary for two reasons:

1. To establish that the current system design satisfies all the constraints.
2. To provide system variable values for use in evaluating the component energy terms for energy-related objective functions.

The operating point of the system for a given time period in the load profile is found by solving a set of simultaneous equations, formed from the component residual equations, by use of the generalized reduced gradient algorithm developed by Lasdon et al. (1978).

If maximum efficiency of the optimization solution process is to be obtained, then the characteristics of the optimization algorithm must match those of the problem. Many classical optimization problems are solved using gradient-based techniques that employ the derivatives of the objective and constraint functions to assess the location of the desired optimum. However it is common for components to be available in a range of discrete sizes. This discrete characteristic of the problem variables severely affects the stability of the numerical procedures required to calculate the derivatives and suggests that HVAC optimized design problems would best be solved using a direct search algorithm that based its search strategy on a simple comparison of the function values at a series of trial points.

An examination of available direct search algorithms revealed that none had been developed specifically for use with discrete problem variables and nonlinear constraints and objective functions. The most successful algorithm implemented in this research is a modified version of the Hooke and Jeeves (1960) pattern search. This algorithm bases its search strategy on a series of exploratory probes about the current solution point, followed by an accelerated move towards the optimum. Although this algorithm has proved a useful tool for investigating

the characteristics of HVAC optimized design problems, its suitability for solving them is limited when the solution lies on a constraint, as the algorithm tends to fail when this is the case.

GENERAL PROBLEM CHARACTERISTICS AND EXAMPLE OPTIMIZATION

In developing an algorithm to solve HVAC optimization problems, it is important to consider the general characteristics of the problem. These have been investigated through a variety of problems, of which the most informative have been the optimized design of a swimming pool heat recovery system. Two schemes were considered, a run-around coil system (Figure 4) and a package chiller heat recovery system (Figure 5). The run-around coil system is comprised of an uncontrolled run-around coil, which recovers waste heat from the exhaust air of the swimming pool hall and transfers it to the colder fresh air intake. Any additional heat requirement is supplied via a heating coil, which is proportionally controlled by the action of a three-port diverting valve. Conversely, in the package chiller system, the total heat requirement is supplied solely by the package chiller, which recovers waste heat from the exhaust air via a cooling coil connected to the evaporator. Heat is supplied from the condenser via a heating coil that is proportionally controlled by the action of a three-port diverting valve. Operation of the chiller is controlled by varying the speed of the centrifugal chiller proportionally to the condenser water flow temperature.

The constraints imposed on each system design are: all components must operate within their performance limits (the "undersizing" constraint), the face velocity of each coil must not exceed 8.2 ft/s (2.5 m/s), the coil water velocity per water circuit must not exceed 5.9 ft/s (1.8 m/s) and finally there must be sufficient water tubes in each coil to form the required number of circuits. The conditions under which each system is required to operate are that the system must supply air at a temperature of 82.4 F (28° C) and a moisture content of 0.0062 lb/lb (kg/kg) with a fresh air supply of 50.9 F (10.5° C) and same moisture content. The return air condition is set at a temperature of 82.4 F (28° C) and moisture content of 0.0132 lb/lb (kg/kg). Both supply and return air are provided at a mass flow rate of 952.4 lb/min (7.2 kg/s).

The problem variables, product ranges, and solution for a net energy consumption of the package chiller system are given in Table 1. The solution indicates that the major factor influencing the size of the coil in this problem is the chiller duty, as the solution tends towards a coil of small face area. Lower limits are placed on the height and width of this coil by the undersizing constraint for the coil in meeting the required supply air condition. The solution obtained for the condenser water mass flow rate and temperature set point, together with the size of coil, just meet the correct controlled air temperature. The size of cooling coil has little effect on the chiller duty, and thus the main influence on its size is the exhaust fan power, giving a coil of maximum face area.

Problem Characteristics

The behavior of the objective and constraint functions is difficult to describe as more than a function of two dimensions. Figure 6 shows the net energy consumption of the package chiller system in relation to the number of coil rows and chiller size. This illustrates the general characteristic of the solution to lie on one or more constraint. It is, however, less common for the solution to lie in a "valley bottom," the more common trait is illustrated in Figure 7. This shows the capital cost in relation to the width and height of both heating coils of the run-around coil system. The discontinuity in this function is caused by a change in manufacturing techniques and is a common characteristic of all capital cost related functions.

It is common for the objective function to be independent of certain variables, their value only affecting the constraint functions. This is most notable for the capital cost objective function in which the system's operating variables are rarely parameters in the capital cost models and only become active in the optimization if a constraint is encountered.

A similar characteristic that causes numerical problems, arises when the optimum value of a variable is only marginally influenced by the objective function. Numerical instability can occur for energy-related objective functions when either a change in value of a variable or a combination of variables produces a small change in the value of the objective function. The cause of this instability is that when small changes in energy-related objective

functions occur, the value of the change is more influenced by the accuracy of the operating point found by the system simulation algorithm than by the actual change in component performance.

Figure 8 illustrates the unstable nature of the net energy objective function in relation to the supply fan diameter and additional heating coil of the run-around coil system. This instability occurs due to the strong interaction between coil and fan, the fan power acting to offset the coil duty. Marginal changes in the objective function value are then influenced by inaccurate changes in the operating point of the extract fan even though these are only in the order of 0.06 % for the fans power. This characteristic implies that further research is required to establish the level of accuracy required for a change in value of the objective function to be significant.

CONCLUSIONS

A component-based procedure has been established for the definition of HVAC system optimized design problems. Consideration has been given to the effect that the simulation of the system's performance has on the integrity of the objective and constraint function evaluations. The procedure has been implemented in a modular suite of computer programs.

Solution of HVAC system optimization problems is by the application of direct search methods. The pattern search algorithm implemented has proved a useful tool in solving these problems but has a tendency to fail when constraints are encountered. With a view to developing a more robust algorithm, the general characteristics of the problem have been investigated through examples. The characteristics of the problem are that the problem variables are a mixture of discrete and continuous variables, the objective and constraint functions are non linear, and the solutions tend to lie on one or more constraint.

Apart from matching these characteristics, future algorithms must cope with the difficulties that arise from the objective and constraint function formulations. The mathematical formulation of a constraint representing the performance of the system or components outside the normal range of operation is dependent upon the system simulation solution procedure. Should such a constraint in future research prove difficult to formulate, then the optimization algorithm will be limited to one that operates solely within the feasible region or with simple rejection of infeasible points.

In order to eliminate numerical instability of the objective functions, additional research is required to establish the level of accuracy that is acceptable for changes in the objective function values.

REFERENCES

- Hanby, V.I.; and Wright, J.A. 1986. "A component modeling methodology for HVAC optimisation studies." Proceedings of the Second International Conference on System Simulation in Building. Laboratoire de Thermodynamique, Universite de Liege, Belgium.
- Hooke, R.; and Jeeves, T.A. 1960. "Direct search solution of numerical and statistical problems." Journal of Association of Computing Machinery. Vol. 8. pp. 212-229.
- Lasdon, L.S.; Warren, A.D.; Jain, A.; and Ratner, M. 1978. "Design and Testing of a generalised reduced gradient code for non linear programming." ACM Transactions on Mathematical Software, V4/1. pp. 31-50.
- Milbank, N.O.; Dowdall, J.P.; and Slater A. 1971. "Investigation of maintenance and energy costs for services in office buildings." Building Research Station Current Paper 38/71. Building Research Station, Garston, Watford, U.K.
- Murray, M.A.P. 1984. "Components based performance simulation of HVAC systems." Doctoral Thesis. University of Technology, Loughborough, U.K.
- Stoecker, W.F. 1971. Design of thermal systems. McGraw-Hill Book Company.
- Wright, J.A. 1986. "The optimised design of HVAC systems." Doctoral Thesis, University of Technology, Loughborough, U.K.

TABLE 1
Product Range and Solution for the Optimized Design of the Package Chiller System
(Net Energy Objective Function)

COMPONENT	VARIABLE	RANGE	SOLUTION
Supply Fan	Diameter	35 - 44 inch (0.9 - 1.12 m)	44 inch (1.12 m)
Extract Fan	Diameter	35 - 44 inch (0.9 - 1.12 m)	44 inch (1.12 m)
Heating Coil	No. of Rows	2 - 10	4
	Width	39 - 79 inch (1.0 - 2.0 m)	59 inch (1.5 m)
	Height	39 - 79 inch (1.0 - 2.0 m)	69 inch (1.75 m)
Cooling Coil	Water Circuits	10 - 30	30
	No. of Rows	2 - 10	2
	Width	39 - 79 inch (1.0 - 2.0 m)	79 inch (2.0 m)
	Height	39 - 79 inch (1.0 - 2.0 m)	79 inch (2.0 m)
Chiller	Water Circuits	10 - 30	20
	Catalog No.	50 - 90	70
Condenser	Mass Flow Rate	264.5 - 793.7 lb/min (2.0-6.0 kg/s)	343.9 lb/min (2.6 kg/s)
	Temperature (set point)	85.1 - 121.1 F (29.5-49.5 °C)	101.3 F (38.5 °C)
Evaporator	Temperature	41.0 - 48.2 F (5.0 - 9.0 °C)	48.2 F (9.0 °C)

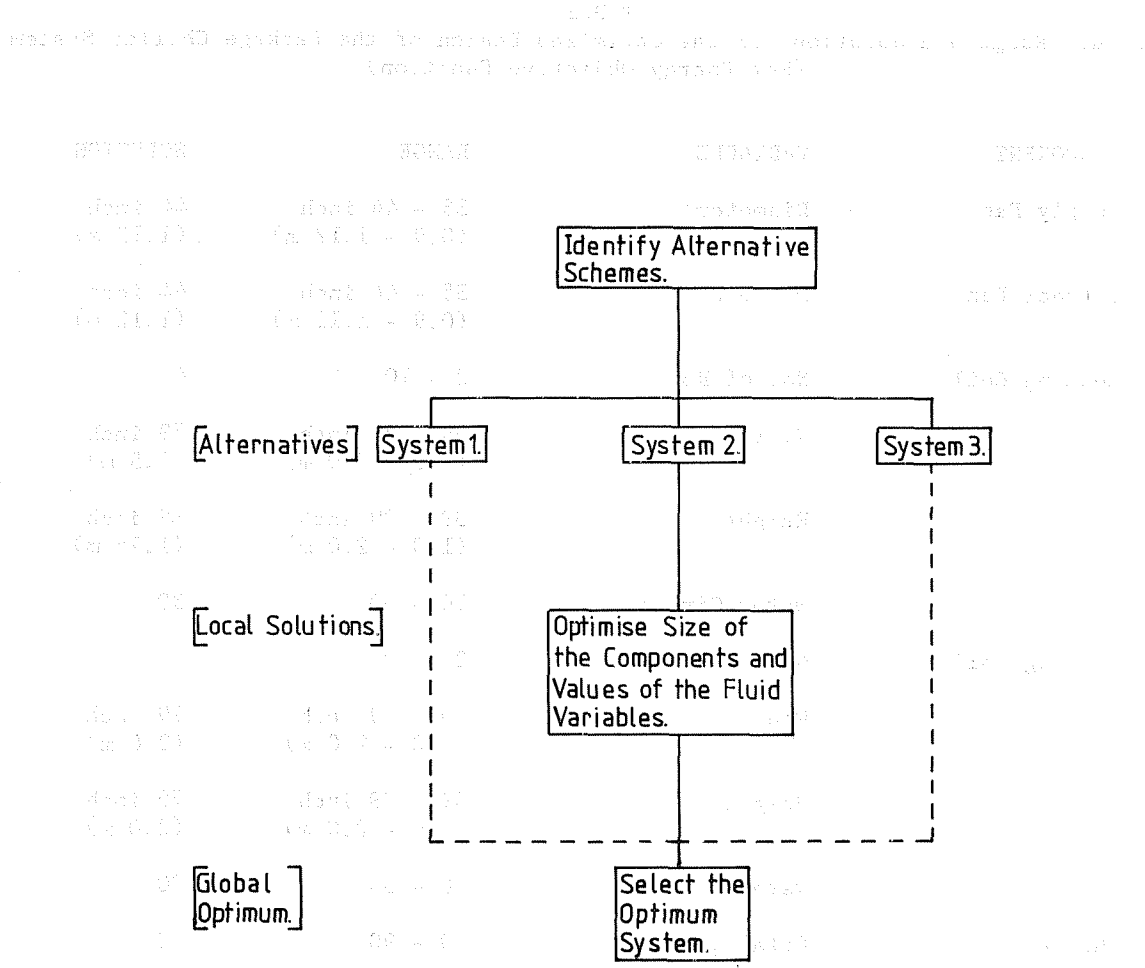

Figure 1. The optimized design of HVAC systems

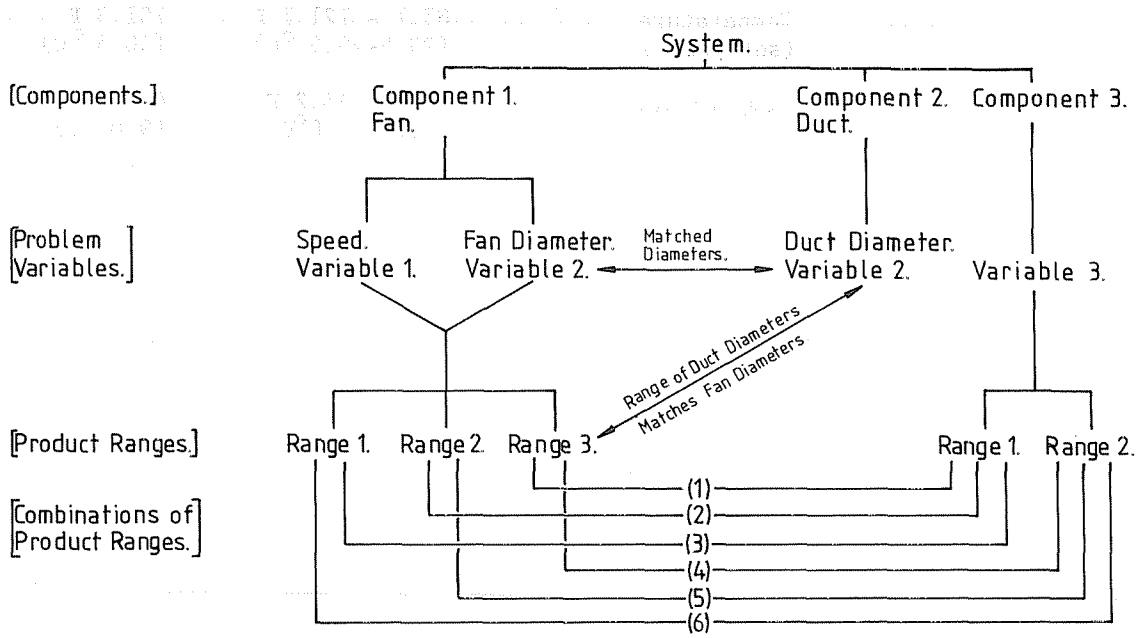

Figure 2. The relationships in optimized component selection

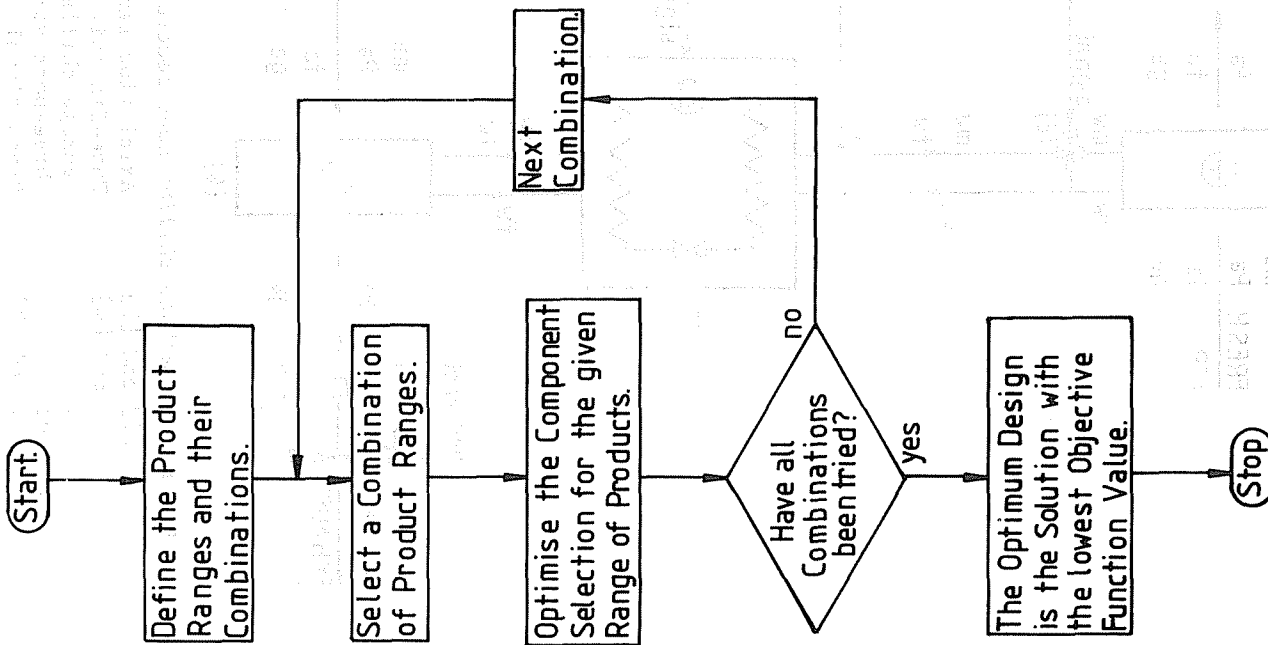

Figure 3. The process of optimized component selection.

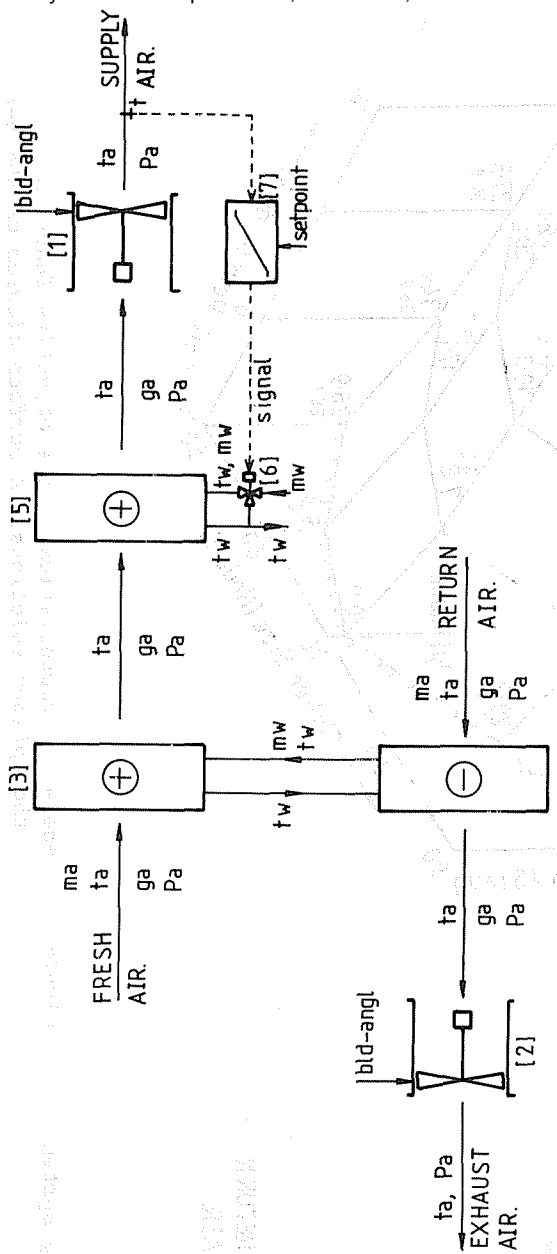

Figure 4. Run-around coil system

- Node: [1] and [2] Axial flow fan
- [3], [4], and [5] Tube-fin coil
- [6] Three-port valve
- [7] Proportional controller

Variable: ma	Mass flow rate of air
ta	Air temperature
ga	Air moisture content
Pa	Pressure (total)
mw	Mass flow rate of water
tw	Water temperature
bld-angl	Fan blade angle
set point	Controller set point
signal	Controller output-signal

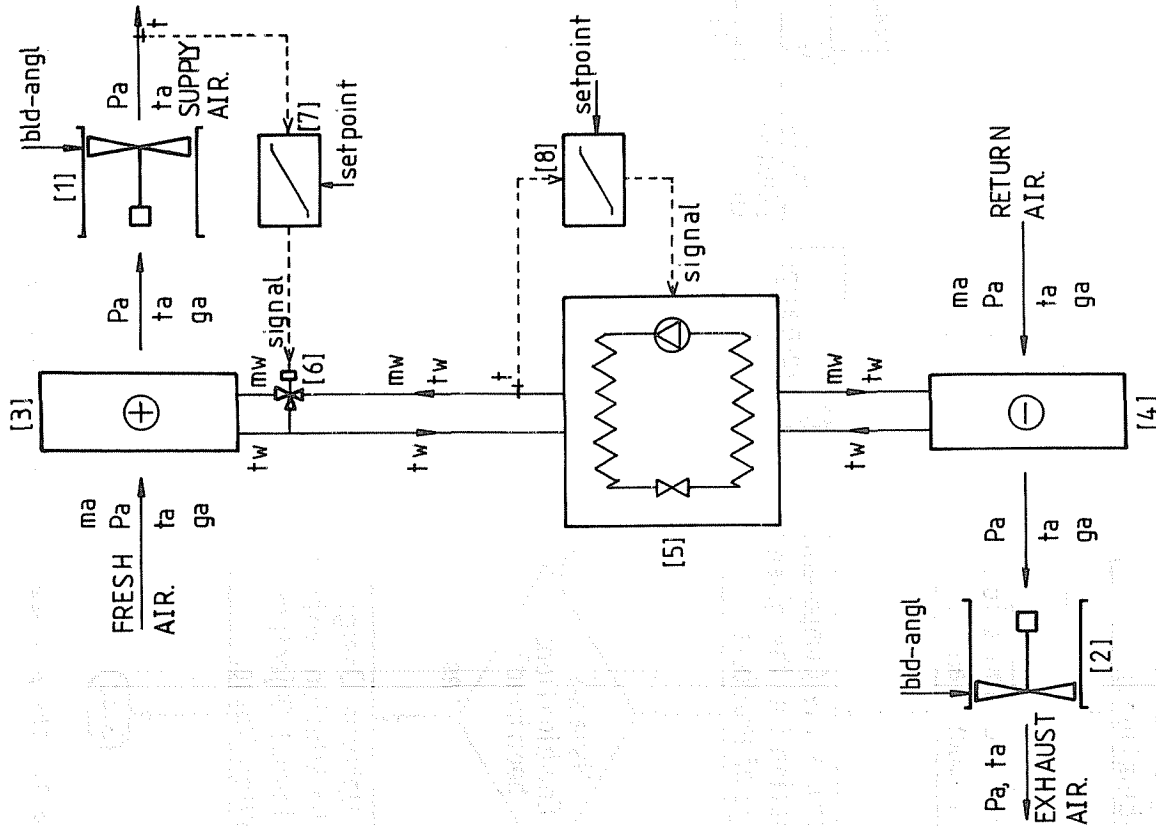

Figure 5. Package chiller heat recovery system
 Node: [1] and [2] Axial flow fan
 [3] and [4] Tube-fin coil
 [5] Package chiller
 [6] Three-port valve
 [7] and [8] Proportional controller

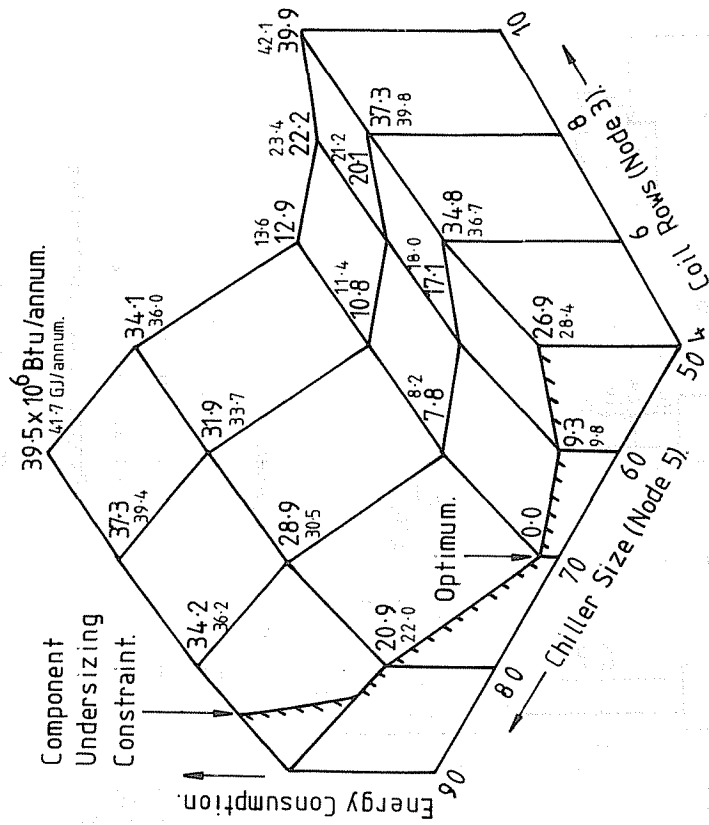

Figure 6. General characteristics of the objective function and of the optimum solutions. A surface diagram of the net energy consumption of the package chiller system illustrated in Figure 5. The energy consumption is shown as the increase in value over that at the optimum.

682 Pounds Sterling
1084 U.S. Dollars.

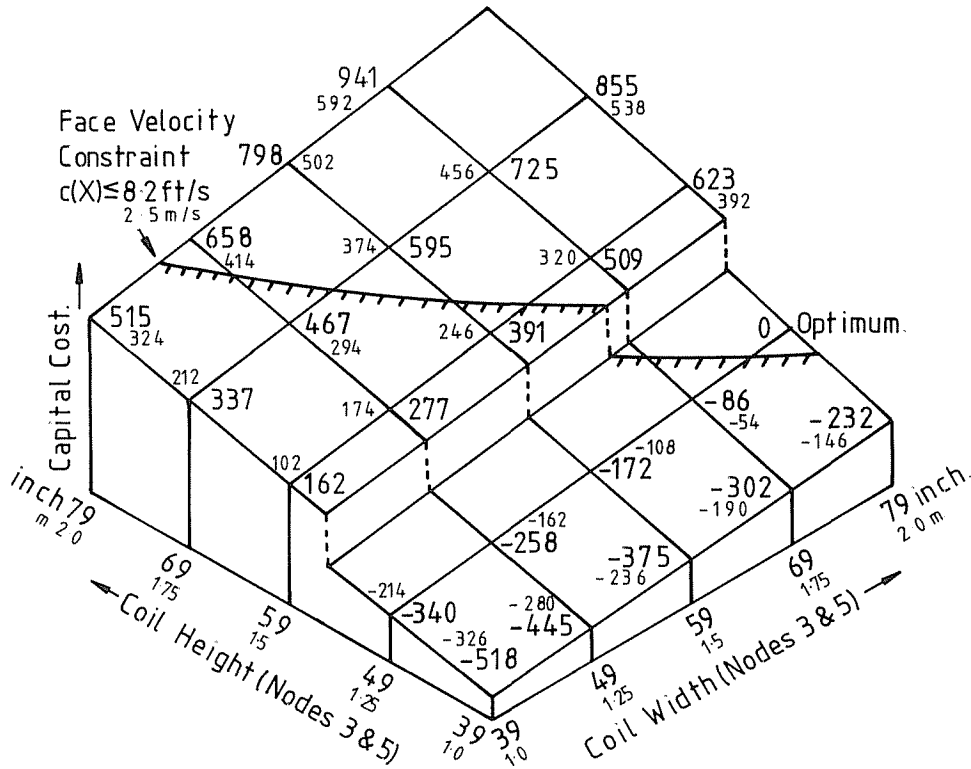

Figure 7. General characteristics of the objective function and of the optimum solutions. A surface diagram of the first cost of the run-around coil system illustrated in Figure 4. The cost is shown as the increase in value over that at the optimum

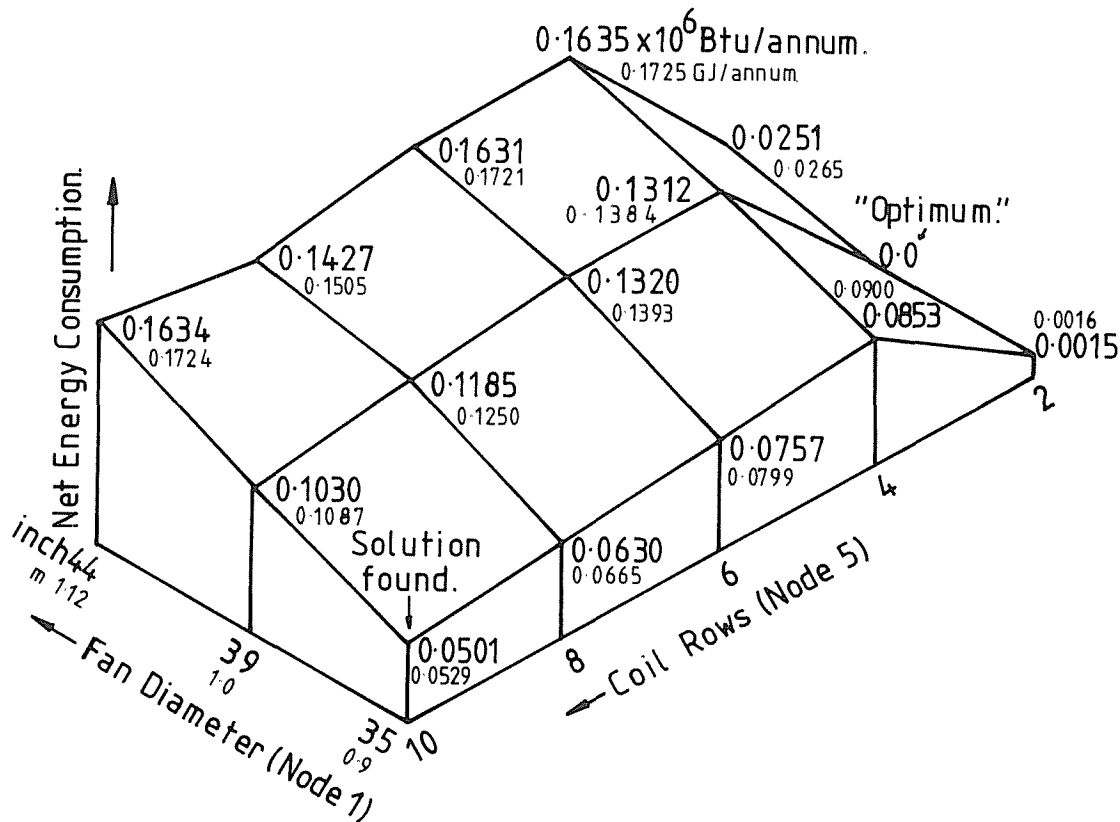

Figure 8. Numerical instability of the objective function. A surface diagram of the net energy consumption of the run-around coil system illustrated in Figure 4. The energy consumption is shown as the increase in value over that at the optimum (644.9×10^6 Btu/annum, 680.4 GJ/annum).