



This item was submitted to Loughborough's Institutional Repository (<https://dspace.lboro.ac.uk/>) by the author and is made available under the following Creative Commons Licence conditions.

 **creative commons**  
C O M M O N S D E E D

**Attribution-NonCommercial-NoDerivs 2.5**

**You are free:**

- to copy, distribute, display, and perform the work

**Under the following conditions:**

 **Attribution.** You must attribute the work in the manner specified by the author or licensor.

 **Noncommercial.** You may not use this work for commercial purposes.

 **No Derivative Works.** You may not alter, transform, or build upon this work.

- For any reuse or distribution, you must make clear to others the license terms of this work.
- Any of these conditions can be waived if you get permission from the copyright holder.

**Your fair use and other rights are in no way affected by the above.**

This is a human-readable summary of the [Legal Code \(the full license\)](#).

[Disclaimer](#) 

For the full text of this licence, please go to:  
<http://creativecommons.org/licenses/by-nc-nd/2.5/>

# INTERNATIONAL JOURNAL OF CHEMICAL REACTOR ENGINEERING

---

*Volume 7*

2009

*Article A69*

---

## **Transdermal Drug Delivery by Microneedles: Does Skin Metabolism Matter?**

Barrak Al-Qallaf\*      Daisuke Mori<sup>†</sup>      Lola Olatunji<sup>‡</sup>  
Diganta Bhusan Das\*\*      Zhanfeng Cui<sup>††</sup>

\*University of Oxford, b\_alqallaf@hotmail.com

<sup>†</sup>Biocom Systems Inc., daisuke.mori@biocom.co.jp

<sup>‡</sup>Loughborough University, b\_118ers@hotmail.co.uk

\*\*Loughborough University, d.b.das@lboro.ac.uk

<sup>††</sup>University of Oxford, zhanfeng.cui@eng.ox.ac.uk

ISSN 1542-6580

Copyright ©2009 The Berkeley Electronic Press. All rights reserved.

# Transdermal Drug Delivery by Microneedles: Does Skin Metabolism Matter?

Barrak Al-Qallaf, Daisuke Mori, Lola Olatunji, Diganta Bhusan Das, and Zhanfeng Cui

## Abstract

Microneedle arrays have been shown to increase skin permeability for the transdermal delivery of drugs with high molecular weights. Various theoretical studies have been proposed to predict the drug transport behaviour after drug injection using microneedles. However it is important for the optimal design of microneedle systems to consider the effects of biological factors such as skin metabolism and variations in pharmacokinetic parameters as well as to improve the enhancement of skin permeability. A mathematical model for microneedle systems is introduced and applied to simulate the verapamil transport with metabolism in the skin. A comparative analysis for a transdermal delivery of verapamil from microneedles is presented in this paper. The results indicate that the skin metabolism does not markedly affect the skin permeation after verapamil injection using microneedles.

**KEYWORDS:** microneedles, transdermal drug delivery, pharmacokinetics, modelling, skin metabolism, reaction

## INTRODUCTION

A number of mathematical frameworks have been developed for evaluating both the skin permeation and blood concentration of drug delivered using microneedle arrays (Al-Qallaf and Das, 2009a; Al-Qallaf and Das, 2009b, Davidson et al, 2008; Al-Qallaf et al, 2007; Lv et al, 2006; McAllister et al, 2003). In most of these cases, the metabolism of the drug has not been considered. Consequently the skin permeation and blood concentration of the drug have been modelled assuming no drug metabolism in the viable skin. For example, we have previously evaluated the effects of volume of distribution ( $V_b$ ) and elimination rate constant ( $K_e$ ) on the fentanyl concentration in blood without considering the skin metabolism (Al-Qallaf et al, 2007; McAllister et al, 2003). Other general mathematical models for molecule transport across skin have also been proposed which have not included the influence of skin metabolism, see e.g., the reviews by Godin and Touitou (2007) and, Yamashita and Hashida (2003). Similarly, Simon et al (2006) proposed a mathematical model of iontophoretic transdermal drug delivery and assumed no drug metabolism in the viable skin. Although these modelling studies were useful, there are a number of situations where drug metabolism in skin during transdermal delivery in general, and microneedle arrays specifically, might be important. For example, Yamashita and Hashida (2003) argue that the skin metabolism may be an important factor for developing transdermal drug delivery approach. Indeed many studies considered the influence of drug metabolism in skin (Boderke et al, 200; Sugibayashi et al, 1999; Bando et al, 1997; Auton, 1993). However, these studies are insufficient in determining the implications of the skin metabolism for transdermal drug delivery using microneedles. This is obvious because the drugs are injected in the viable epidermis in this case instead of the top of the skin, and the influence of the path lengths for drug transport across skin on the kinetics of metabolism may be different. This has been explained in more detail in the subsequent sections.

The purpose of this paper is to develop a mathematical framework to examine the importance of considering skin metabolism for drug delivery using microneedle arrays. In particular, we are interested to determine the implications of verapamil delivery using microneedle arrays. Verapamil is used for many medical purposes such as preventing heart attack (Simonetti et al, 1986) lowering blood pressure (Trewet and Ernest, 2008), and stopping cluster headache attacks (Tobin and Flitman, 2008) and diarrhea due to microscopic colitis (Scheidler and Meiselman, 2001). The administration of verapamil is often done orally. However it has been shown that the bioavailability of verapamil may be reduced by 80-90% if the oral route is chosen (Choi et al, 2008, Michel et al, 2006). On the other hand, others argue that it can be delivered by transdermal route which seems to improve the bioavailability of verapamil (Shah et al, 1992a). Shah et al. (1992b)

concluded that not all the amount of delivered verapamil reached the blood circulation. One of the possible reasons to explain this effect was that the verapamil could be metabolized in the skin (Shah et al 1992b). Assuming that one wishes to adopt transdermal routes for delivery of verapamil, it is not certain what role the microneedle arrays could play for its delivery. To this end, one needs to determine the advantage of microneedles over a normal patch for verapamil delivery and determine the implications of verapamil metabolism in skin. To analyse these issues, we have carried out simulations for both common transdermal patch and microneedle arrays in this paper.

As mentioned previously, many theoretical models of transdermal drug delivery have been proposed to study the influence of skin metabolism. However, most of these models have studied the influence of skin metabolism for the full skin thickness (i.e., the stratum corneum and viable skin together). In fact, skin metabolism occurs primarily in the viable epidermis (Amsden and Goosen, 1995). In order to validate this fact we have carried out simulations of the common patch with two hypothetical cases. To make a logical comparison, the simulations of these two hypothetical cases have been carried out for the same transdermal drug delivery system (i.e., common patch) with the same input parameters. The first case represents the common patch on the top of the stratum corneum. The second case represents the common patch on the top of the viable epidermis. A comparison for these two hypothetical cases has been presented to show the influence of skin metabolism. Based on the result of this comparison, we have carried out another simulation for the microneedle arrays. The simulations of microneedles have been carried out by adopting a previous microneedle model (Davidson et al, 2008). In addition, several studies have been obtained by carrying out simulations using SKIN-CAD<sup>®</sup> (Kimura and Tojo, 2007; Tojo and Hikima, 2007; Mori et al., 2003). However, to our best knowledge, skin metabolism has not been considered during the simulations carried out for these previous studies.

In this work, a study of both skin permeation and verapamil concentration in blood have been carried out based on a diffusion model including a metabolic process. Improving upon our previous work (Davidson et al, 2008; Al-Qallaf et al, 2007) we have introduced mono and bi-layer diffusion models with two compartment model to estimate verapamil concentration in blood when either applied as a patch or injected using microneedle. In all cases, the cumulative amounts of verapamil permeated per unit area of skin with and without skin metabolism have been numerically determined. Moreover, the distribution of verapamil across skin for the transdermal delivery using microneedles has been obtained. Therefore, the analysis of both verapamil permeation and the verapamil concentration in blood are thought to be useful. In particular, this is important to identify the impact of skin metabolism when applying the transdermal delivery of

verapamil using microneedles. In fact, this helps to clarify the argument about the assumption of neglecting skin metabolism in viable skin as discussed previously.

## MODELING STRATEGY

A schematic diagram of the developed mathematical framework of transdermal delivery of verapamil for both the patch and microneedle arrays is illustrated in Figure 1. There are two main transdermal drug delivery systems in the figure: a transdermal patch containing verapamil at a homogeneous concentration (Shah et al, 1992c) and a microneedle array coated with verapamil solution (Davidson et al, 2008). Application of the transdermal patch is divided into two hypothetical cases that represent application on the top of either the stratum corneum or viable epidermis.

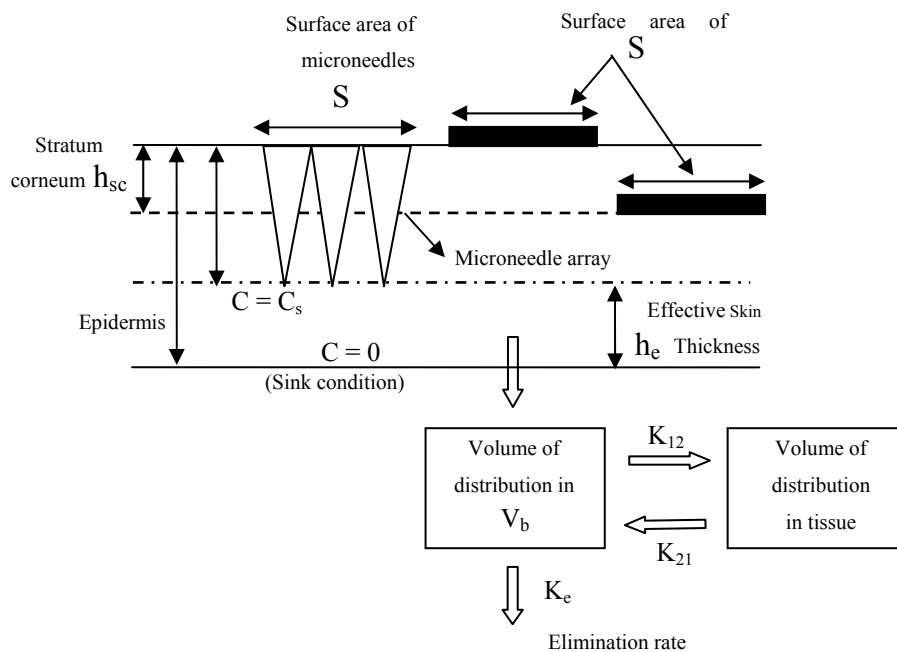

Fig.1. Schematic diagram of transdermal drug delivery for both patch and microneedle arrays (adopted from Al-Qallaf et al.(2007))

In the first case, verapamil penetrates the stratum corneum, partitions towards and penetrates the viable epidermis and then enters the blood circulation (Tojo, 1987). In the second case, verapamil diffuses across the viable epidermis and then is absorbed by the blood circulation. Although this is a hypothetical case designed purely for the purpose of this study, the result obtained for this case is expected to be useful since it has been shown that drug may be metabolized in the viable epidermis (Amsden and Goosen, 1995). In the figure,  $S_a$  is the surface area

of both the transdermal patch and microneedle arrays,  $L$  is the penetration depth of microneedles,  $H_{\text{eff}}$  is the effective skin thickness (i.e., effective path length of molecules in tissue) that verapamil molecules can pass in the tissue from microneedle which depends on the needle geometry (Davidson et al, 2008). Verapamil is defined to get absorbed into two compartments (i.e., blood compartment and tissue compartment) with first order elimination kinetics (Tojo, 1987).

### Model assumptions

The mathematical framework in this work is based on the following assumptions:

(1) The skin metabolism is defined to follow first order kinetics (Lee et al, 1996; Sato and Mine, 1996; Tojo et al, 1985; Hadgraft, 1980; Tu et al, 1979). This assumption has been chosen since most of the mathematical models that have been presented to describe the metabolic kinetics of drug during its diffusion through skin follow the first order kinetics as compared to Michaelis-Menten kinetics (Sugibayashi et al, 1999; Sugibayashi, et al 1996; Higuchi et al, 1983). Furthermore, Lipscomb and Poet (2008) concluded that in vivo drug concentration is usually below the Michaelis-Menten constant ( $K_m$ ) which leads to essentially consider the first order kinetics. In particular, the transdermal drug delivery has been reported to follow first order kinetics (Papa et al, 2009; Prodduturi et al 2009; Shakeel et al, 2008).

(2) The distribution of the enzyme in the viable skin is assumed to be uniform (Boderke et al, 2000). Liu et al. (1990) proposed a theoretical diffusion model to examine the enzyme distribution. This model was based on the assumption of uniform enzyme distribution. The outcome of this study supports this assumption since the theoretical results agreed well with their experimental data. In another study, a mathematical absorption model with skin enzyme distribution has been developed (Hakima et al, 2006). The investigation shows a uniform enzyme distribution across skin. No significant differences have been observed between the uniform enzyme distribution model and non-uniform enzyme distribution model (Sugibayashi et al, 1999, Tojo et al, 1994). Therefore, this assumption is easily applicable to represent the drug diffusion profile across skin (Bando et al, 1996) which leads to a simplified theoretical model (Yamaguchi et al, 2006; Boderke et al, 2000).

(3) For the simulations carried out using SKIN-CAD<sup>®</sup> (Biocoms systems, 2006), the transport of verapamil across skin is described by one-dimensional diffusion model (Lv et al, 2006; Boderke et al, 2000). For the sake of simplicity, the one-dimensional diffusion has been assumed as this allows one to consider the effects of drug metabolism alone and not any other effects (e.g., dimensionality). Such assumption has been used in many mathematical models to describe the

transdermal drug delivery using microneedles (Lv et al, 2006; McAllister et al, 2003). In particular, several studies have been obtained by carrying out simulations using SKIN-CAD<sup>®</sup> which assume one-dimensional method (Kimura and Tojo, 2007; Tojo and Hikima, 2007; Mori et al, 2003). The numerical results agreed well with the experimental data.

(4) The diffusion coefficients are assumed to be constant in each layer (Boderke et al, 2000) although they may be different. The diffusion coefficient of verapamil has been shown to be three orders of magnitude less in the stratum corneum as compared to viable skin (Shah et al 1992a). It has been defined that the diffusion coefficient in the viable epidermis and dermis are of the same magnitude (Yamaguchi et al, 2008; Tojo, 2005). Therefore, it is acceptable to assume a constant value of the diffusion coefficient across the viable skin.

(5) All the verapamil molecules are assumed to be taken up by the blood circulation (Al-Qallaf et al, 2007). This assumption has been previously explained in detail in previous publications e.g. Al-Qalaf et al (2009c) and Davidson et al (2008).

(6) The body pharmacokinetics is defined to follow two-compartment model (Shah et al, 1992c; Anderson et al, 1982). The two-compartment model for verapamil has been chosen in consistency with previous studies which indicate this to be a better model as compared to the one-compartment model (Bertera et al, 2008; Syvanen et al, 2008). Ahmed et al. (1992) investigated the pharmacokinetic behaviour of verapamil for a range of models. Their results showed that the two-compartment model was the most appropriate model as compared to one-compartment and three-compartment models.

(7) At  $x=h$  (Figure 1), the concentration of verapamil is defined to be zero (sink condition) (Al-Qallaf et al, 2007; Mori et al, 2003; Tojo, 2005). This assumption has also been previously explained in detail in Al-Qalaf et al (2009c) and Davidson et al (2008).

(8) The back diffusion of verapamil in skin is ignored (Al-Qallaf et al, 2007; Tojo, 2005; Shah et al, 1992c). This has been done since the diffusion coefficient of verapamil is small in the stratum corneum (Shah et al, 1992c). Therefore, it seems to be acceptable to ignore the back diffusion (Tojo, 2005).

### **Governing equations characterizing the skin concentration**

The skin is represented by a bi-layer model which has two layers, stratum corneum and viable skin.

In the case of neglecting the skin metabolism, the movement of verapamil across skin (Fig. 1) is based on Fick's second law as:



Across the stratum corneum

$$\frac{\partial C_{sc}}{\partial t} = D_{sc} \frac{\partial^2 C_{sc}}{\partial x^2} ; \quad 0 < x < h_{sc} \quad (1)$$

Across the viable skin

$$\frac{\partial C_{vs}}{\partial t} = D_{vs} \frac{\partial^2 C_{vs}}{\partial x^2} ; \quad h_{sc} < x < h \quad (2)$$

The initial verapamil concentration in skin is assumed to be zero. The boundary conditions used in this work for solving all the governing equations are:

At the surface of the skin, the verapamil concentration is:

$$C = C_s \quad \text{at} \quad x = 0 \quad (0 < t \leq t_a) \quad (3)$$

Verapamil is assumed to be delivered at a constant rate, i.e., a constant skin surface concentration is maintained (Shah et al, 1992c).

At the interface between stratum corneum and viable skin, the verapamil concentration is:

$$C_{sc} = K_{sc/vs} C_{vs} \quad \text{at} \quad x = h_{sc} \quad (0 < t) \quad (4)$$

At the bottom of the skin epidermis, the concentration of verapamil is:

$$C = 0 \quad \text{at} \quad x = h \quad (0 < t) \quad (5)$$

where  $C$  is the verapamil concentration,  $D$  is the diffusion coefficient and the subscripts  $s$ ,  $sc$  and  $vs$  represent the skin surface, the stratum corneum and the viable skin, respectively,  $t$  is time,  $x$  is the distance in a given skin layer,  $K_{sc/vs}$  is the partition coefficient between the stratum corneum and the viable skin,  $t_a$  is the duration of application of the drug delivery system,  $h_{sc}$  is the stratum corneum thickness and  $h$  is the epidermis thickness (i.e., distance to blood vessel).

As is well known, the metabolic reaction occurs in the viable skin and not in the stratum corneum (Tojo, 2005; Scheafer et al, 1982). Therefore, in the case of considering the metabolism the following equation is used instead of equation (2):

$$\frac{\partial C_{vs}}{\partial t} = D_{vs} \frac{\partial^2 C_{vs}}{\partial x^2} - KC_{vs} \quad (6)$$

where  $K$  is the first order metabolic reaction rate constant.

As shown in Fig. 1, solid microneedles pierce the stratum corneum allowing verapamil to effectively bypass this barrier to diffusion. Therefore, the skin is represented by a mono-layer diffusion model in this work. The injected verapamil by microneedles diffuses across viable skin obeying Fick's second law until it reaches blood vessels (Al-Qallaf et al, 2007; Tojo, 2005; Boderke et al, 2000).

### Governing equations characterizing the blood concentration

The verapamil concentration in blood after imposing the transdermal drug delivery is given by the following two-compartmental pharmacokinetic model (Tojo, 20005);

$$V_b \frac{dC_b}{dt} = \left( \frac{dQ}{dt} \right) S_a - (K_e + K_{12}) C_b V_b + K_{21} C_t V_t \quad (7)$$

$$V_t \frac{dC_t}{dt} = K_{12} C_b V_b - K_{21} C_t V_t \quad (8)$$

where  $K_e$  is the elimination rate constant from the blood compartment,  $K_{12}$  and  $K_{21}$  are the transfer rate constants between compartments,  $dQ/dt$  is the penetration rate of verapamil through the skin,  $S_a$  is the surface area of the delivery system,  $V_b$  and  $V_t$  are the volumes of distribution in the blood and the tissue compartments, respectively,  $C_b$  and  $C_t$  are verapamil concentrations in the blood and the tissue compartments, respectively. The tissue compartment refers to the poorly perfuse non-fatty tissues such as muscle.

### Method of solution

The governing equations with the initial and boundary conditions (1) – (8) have been implemented and solved using the software, SKIN-CAD® (Biocom systems, 2006). The working principle of SKIN-CAD® has been explained in details elsewhere (Al-Qallaf et al, 2007; Tojo, 2005) and are not discussed here. In this work, we have predicted verapamil concentration in blood for the transdermal drug delivery with and without skin metabolism by using mono-layer

and bi-layer diffusion models in case of applying the microneedle arrays and the patch, respectively.

The diffusion of coated verapamil has been modelled in 3D using the software, FEMLAB® (Comsol, 2005). The steady state diffusive flux of verapamil through the blood interface has been calculated by assuming that the concentration of verapamil on the needle surface is constant (Davidson et al, 2008). This allows us to obtain the effective skin thickness by determining the flux from the simulations. The effective skin thickness ( $h_e$ ) in case of applying microneedles is calculated as (Davidson et al, 2008):

$$h_e = D_{vs} \frac{C_a}{J_{ss}} \quad (9)$$

where  $C_a$  is verapamil concentration at the coated surface area of microneedles and  $J_{ss}$  is the average steady-state flux through the blood interface. This is then used as an input parameter for SKIN-CAD®. This approach has been adopted following the work by Davidson et al (2008), which have previously shown that the effective skin thickness is influenced by the microneedle geometry. Equation (9) determines the effective path length of drug molecules once released from the microneedles.

## RESULTS AND DISCUSSION

The impacts of the pharmacokinetic variables with skin metabolism have been studied by Shah et al. (1992c) However, this study was based on transdermal drug delivery by common patch on the top of stratum corneum. According to Shah et al. (1992c) there is a large difference in the pharmacokinetics variables of verapamil. Following this study we have evaluated the influence of pharmacokinetic variables on verapamil with the consideration of skin metabolism for both common patch and microneedle arrays. The values of the pharmacokinetics variables, which were used in our simulations, are shown in Table 1.

Table 1. Pharmacokinetics variables of verapamil obtained from the references.

Parameters	$V_b \times 10^4$ (ml)	$V_t \times 10^4$ (ml)	$K_e \times 10^{-4}$ (s <sup>-1</sup> )	$K_{12} \times 10^{-4}$ (s <sup>-1</sup> )	$K_{21} \times 10^{-4}$ (s <sup>-1</sup> )
References					
Koike et al. (1979)	6.47	8.34	1.50	6.22	3.94
Eichelbaum et al. (1981)	27.39	13.14	0.79	2.12	2.78
Anderson et al. (1982)	2.63	5.18	1.58	2.19	1.11

To further quantify the influence of skin metabolism, we have hypothetically considered the patch at the top of viable epidermis with and without skin metabolism. We hypothesized this case since the metabolic process occurs in the viable epidermis as mentioned previously.

The philosophy of this modelling strategy relies on comparing two hypothetical cases of transdermal delivery of verapamil using patch. This comparison is useful to evaluate the influence of skin metabolism and hence whether to consider the metabolic process in case of coated microneedles with verapamil. There seems to be no previous study which considered the effect of metabolism while using microneedles. To achieve a logical result, those two cases have been simulated with a transdermal patch with the same input parameters. Based on this result, we have carried out simulations of transdermal delivery of verapamil using microneedles. The input parameters of those simulations are shown in Table 2.

Table 2. Model parameters used in this work for analyzing the blood concentration of verapamil penetrated through the skin with and without skin metabolism for both common patch and microneedle arrays (Tojo, 1987; Shah et al, 1992c; Al-Qallaf et al, 2007).

Parameters	Patch		Microneedles	
	case one <sup>a</sup>	case two <sup>b</sup>	case one <sup>c</sup>	case two <sup>d</sup>
Duration for medication (calculation): $t_m$ (hour)	48		8	
Duration of application: $t_d$ (hour)	24		4	
Surface area of microneedle arrays/patch: $S_a$ (cm <sup>2</sup> )	80		2	
Thickness of stratum corneum: $h_{sc}$ (cm)	0.002	-	-	
Distance to blood vessel: $h$ (cm)	0.02	0.018	0.02	
Effective skin thickness: $h_e$ (cm)	-	-	0.00819	0.00827
Diffusion coefficient in stratum corneum: $D_{sc}$ (cm <sup>2</sup> /s)	$7 \times 10^{-11}$	-	-	
Diffusion coefficient in viable skin: $D_{vs}$ (cm <sup>2</sup> /s)	$7 \times 10^{-8}$			
Stratum corneum/viable skin partition coefficient: $K_{sc/vs}$ (-)	8	-	-	
Volume of distribution: $V_b$ (ml)	variable			
Volume of distribution: $V_i$ (ml)	variable			
Elimination rate constant: $K_e$ (s <sup>-1</sup> )	variable			
Transfer rate constant: $K_{12}$ (s <sup>-1</sup> )	variable			
Transfer rate constant: $K_{21}$ (s <sup>-1</sup> )	variable			
Skin surface concentration: $C_s$ (mg/ml)	344	43	43	
First order reaction metabolic rate constant: $K$ (s <sup>-1</sup> )	$5.61 \times 10^{-4}$		-	$5.61 \times 10^{-4}$

### Effect of skin metabolism in case of patch

To examine the implications of skin metabolism in transdermal drug delivery of common patch, we have simulated cumulative amount permeated across the skin and blood concentration of verapamil with and without skin metabolism using model parameters as shown in both Table 1 and Table 2. As previously explained, this has been done by comparing one case where the transdermal patch is applied on the top of the stratum corneum (i.e., case one) with a hypothetical case where it is applied on the top of the viable epidermis without the stratum corneum (i.e., case two).

Fig. 2 shows the cumulative amount of verapamil permeated per unit area of skin with and without metabolism when using the patch for case one. The cumulative amounts of verapamil permeated per unit area of skin with and without metabolism reached approximately  $360 \mu\text{g}/\text{cm}^2$  and  $830 \mu\text{g}/\text{cm}^2$ , respectively, in 24 hours during the patch application. The calculated permeation flux without skin metabolism is approximately 2.3 times higher than that with skin metabolism during the patch application. The results seem to suggest that skin metabolism is an important factor for the transdermal delivery of verapamil.

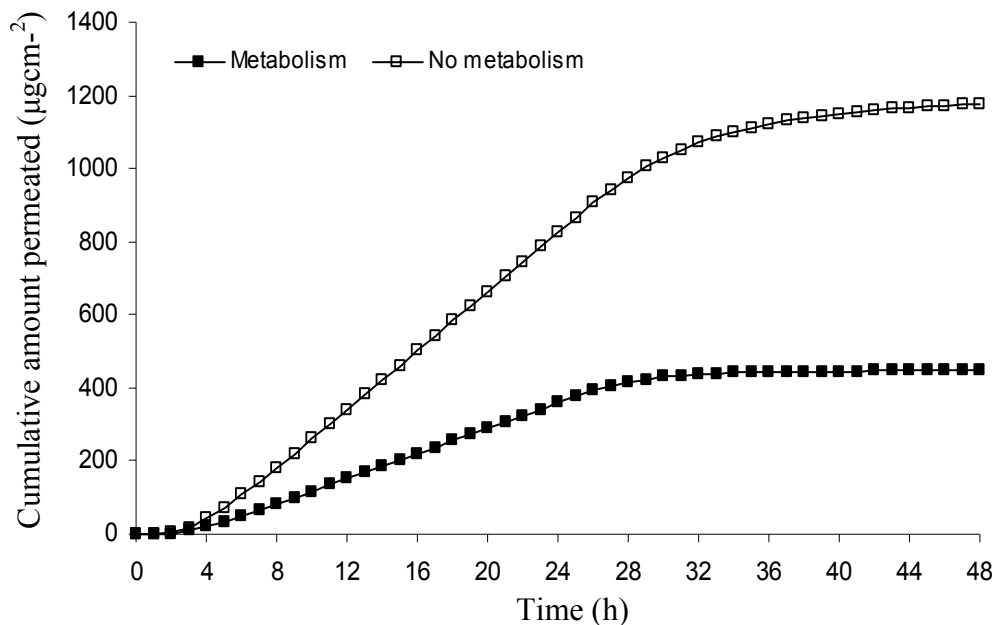

Fig.2. The effect of skin metabolism on the cumulative amount of verapamil permeated into blood per unit area of skin following transdermal delivery using patch (i.e., on the top of the stratum corneum) for the input parameter adopted from Anderson et al(1982).

The effects of skin metabolism on the blood verapamil concentration using patch for case one are shown in Fig. 3. These simulations have been done using various literature values for pharmacokinetic parameters as shown in Table 1. The maximum verapamil concentration in blood ( $C_{b,max}$ ) is different between the two cases (i.e., with and without metabolism). In case of considering skin metabolism, the maximum verapamil concentration in blood ( $C_{b,max}$ ) for the pharmacokinetics parameters given by Anderson et al, (1982) Koike et al. (1979) and Eichelbaum et al. (1981) reached 0.09, 0.04 and 0.02  $\mu\text{g/ml}$ , respectively. On the other hand, it reached 0.21, 0.09 and 0.04  $\mu\text{g/ml}$  in case when skin metabolism is not considered. As expected, the results indicate that skin metabolism has a noticeable influence for the transdermal delivery of patch on the top of the stratum corneum. This result agrees well with the results presented by Shah et al. (1992c) qualitatively. The obtained results show that the skin metabolism is a relatively important factor for the process of transdermal delivery of verapamil if a patch is used (case one) since the difference in the maximum blood concentration is more than double as compared between both cases (i.e., with and without skin metabolism).

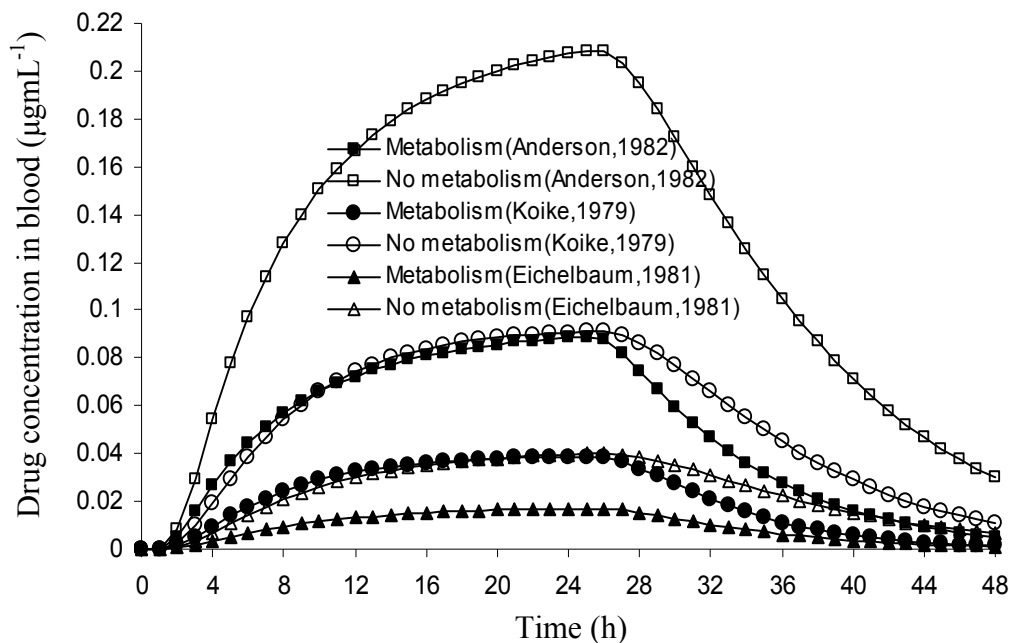

Fig.3. The effects of various pharmacokinetic parameters with and without skin metabolism on the blood verapamil concentration following transdermal delivery using patch (i.e., on the top of the stratum corneum).

In contrast, Fig. 4 represents the cumulative amount of verapamil permeated per unit area of skin with and without skin metabolism for transdermal delivery by applying the patch on the top of the viable epidermis (case two). As explained previously, this case has been proposed to identify the importance of whether to consider the metabolic process in viable epidermis by comparing this case (i.e., case two) with the previous case (i.e., case one). The cumulative amounts of verapamil permeated per unit area of skin with and without metabolism reached approximately  $9700 \mu\text{g}/\text{cm}^2$  and  $14000 \mu\text{g}/\text{cm}^2$ , respectively, in 24 hours. A less remarkable difference has been observed by comparing the simulated data with and without skin metabolism.

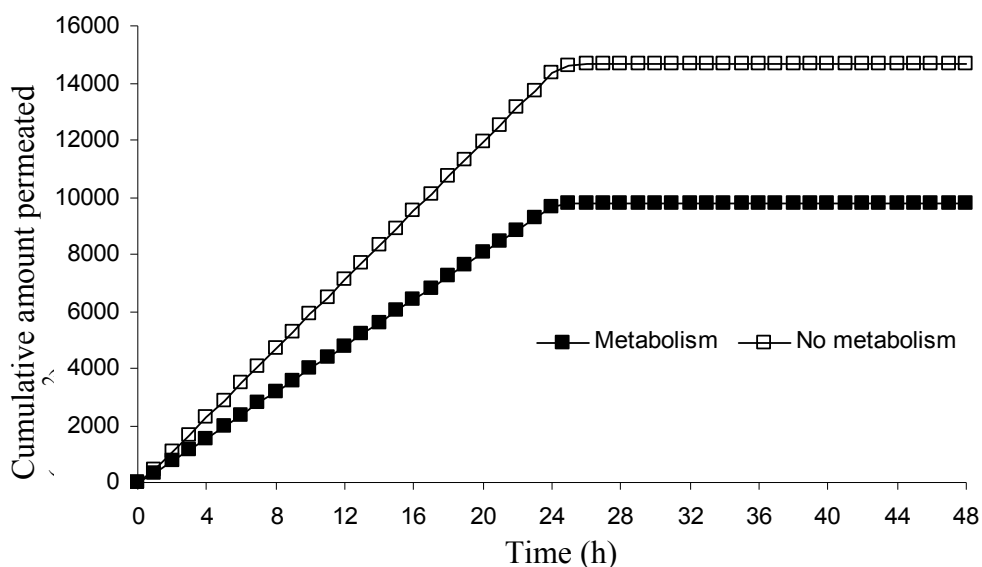

Fig.4. The effect of skin metabolism on the cumulative amount of verapamil permeated into blood per unit area of skin following transdermal delivery using patch (i.e., on the top of the viable epidermis) for the input parameter adopted from Anderson et al (1982)

The simulated blood concentrations in case two are shown in Fig. 5. Less observable differences have been shown for this case as compared with the previous case. This is because the differences in the maximum blood concentration between both cases (i.e., with and without skin metabolism) are less (<30%) than the previous case (>50%) for all the pharmacokinetic parameters presented. For example, in case of considering skin metabolism, the maximum verapamil concentration in blood ( $C_{b,max}$ ) for the pharmacokinetic parameters given by Anderson et al (1982). reached  $2.2 \mu\text{g}/\text{ml}$ , whereas, it reached  $3.2 \mu\text{g}/\text{ml}$  in case when skin metabolism is not considered. Therefore, these simulations show that the skin metabolism has a lower influence which could be neglected as

compared with the case of transdermal delivery of verapamil by applying the patch on the top of stratum corneum (case one). The result of this case motivated us to further study the influence of skin metabolism during the injection of microneedles as discussed below.

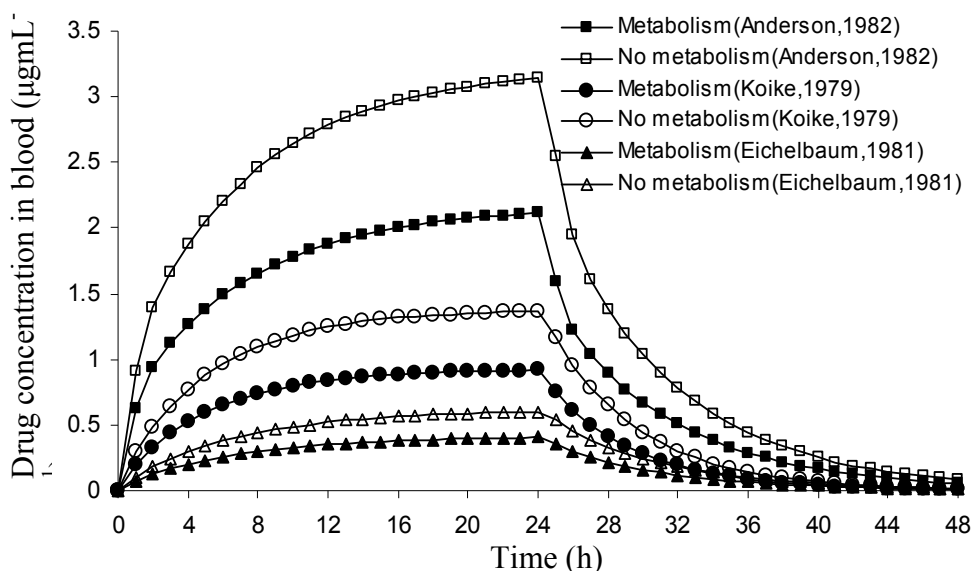

Fig.5. The effects of various pharmacokinetic parameters with and without skin metabolism on the blood verapamil concentration following transdermal delivery using patch (i.e., on the top of the viable epidermis).

### Effect of skin metabolism in case of microneedle systems

Motivated with the previous results and to further study the skin metabolism effect, we have carried out simulations of transdermal delivery of verapamil using microneedle arrays with and without considering skin metabolism of the microneedle model as shown in Fig. 6.

In case of not considering the skin metabolism effects, equation (2) has been used to describe verapamil transport across skin. On the other hand, in case of considering the skin metabolism effects, equation (6) has been used. Then the average flux of both cases has been determined by using FEMLAB® as discussed previously in section 2.2. The effective skin thickness ( $h_e$ ) of transdermal delivery of verapamil using microneedles with and without skin metabolism has been calculated according to equation (9) for the parameters shown in Table 2. The utility of using the effective skin thickness has been previously explained in section 2.2. This has been used as an input parameter to calculate the verapamil concentration in blood by using SKIN-CAD®. No significant difference has been



observed in the effective skin thickness for both cases (i.e., with and without skin metabolism). This similarity appears because the effective skin thickness mainly depends on the flux at the blood interface which was almost the same for both cases since that microneedle reach much nearer to the blood interface where the drugs have only minimal contact with the dermal enzyme (Sugibayashi et al, 1996; Higuch et al , 1983).

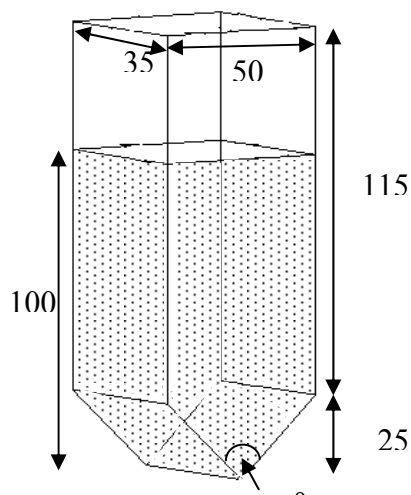

Fig.6. Schematic diagram of a microneedle model used in this work (i.e., the dotted area represents the surface area coated with verapamil).

Figure 7 shows the cumulative amount permeated per unit area of skin for verapamil with and without metabolism. The cumulative amounts of verapamil permeated per unit area of skin with and without metabolism reached approximately  $4900 \mu\text{g}/\text{cm}^2$  and  $5400 \mu\text{g}/\text{cm}^2$ , respectively. These figures also show that the differences between both cases (i.e., with and without skin metabolism) are lower as compared with the previous cases (i.e. case one and two). This result is consistent with our claim to not consider skin metabolism when designing microneedle arrays.

The verapamil concentration in blood starts to reduce after four hours as the duration of application is 4 hours as shown in Figure 8. In all cases, insignificant differences have been observed between both cases (i.e., with and without skin metabolism) (6-9%) when compared to case one (>50%). This is because the maximum verapamil concentration in blood ( $C_{b,\text{max}}$ ) in both cases (i.e., with and without skin metabolism) for the pharmacokinetic parameters given by Anderson et al (1982), Koike et al (1979). and Eichelbaum et al (1981). reached approximately  $0.1 \mu\text{g}/\text{ml}$ ,  $0.04 \mu\text{g}/\text{ml}$  and  $0.01 \mu\text{g}/\text{ml}$ , respectively. Altogether, the obtained results show that the skin metabolism is a relatively weak function of the process of transdermal delivery of verapamil if microneedle is

used since the difference in both the maximum blood concentration and cumulative amount of verapamil permeated into blood per unit area of skin are almost the same as compared between both cases (i.e., with and without skin metabolism).

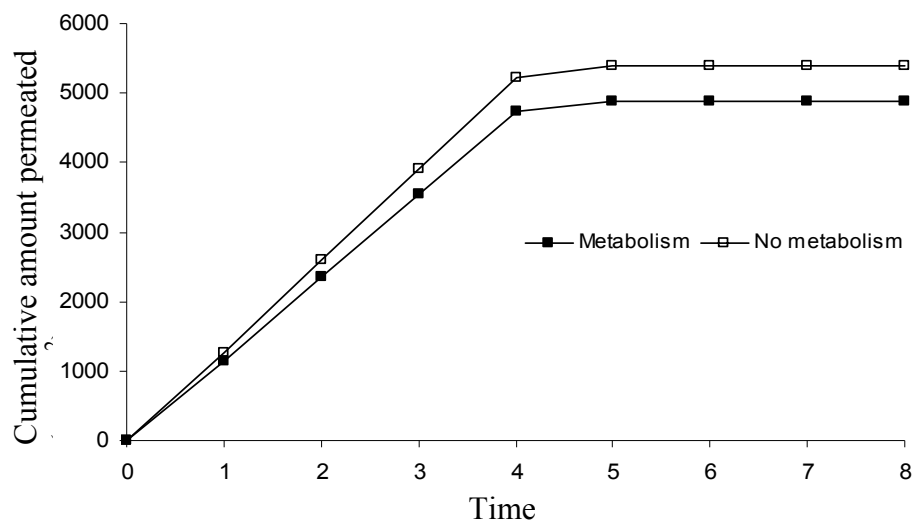

Fig.7. The effect of skin metabolism on the cumulative amount of verapamil permeated into blood per unit area of skin following transdermal delivery using microneedle arrays for the input parameter adopted from Anderson et al (1982).

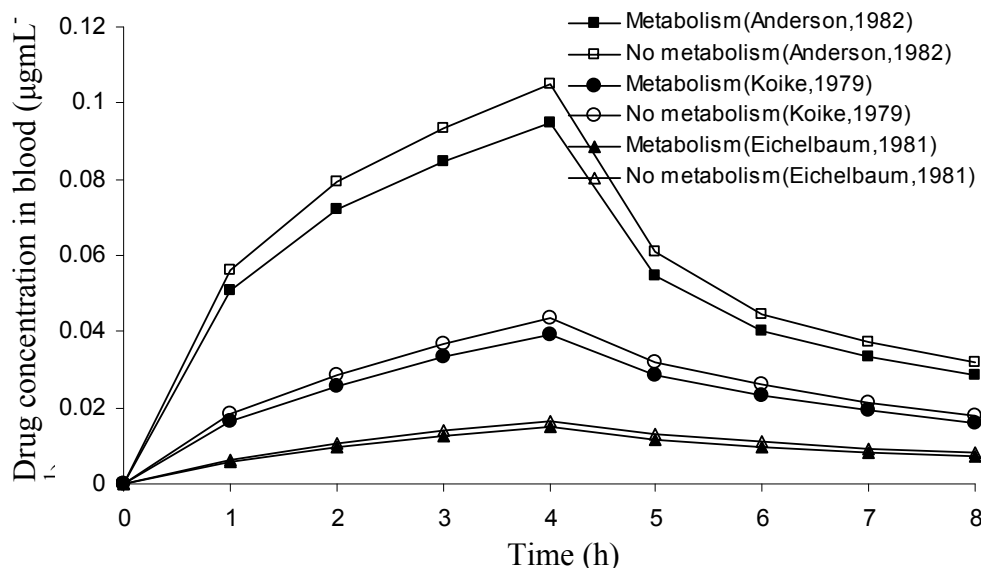

Fig.8. The effect of various pharmacokinetics parameters with and without skin metabolism on the blood verapamil concentration following transdermal delivery using microneedle arrays.

To further achieve a better knowledge of the transdermal delivery of verapamil using microneedles, the distribution of verapamil across skin in 3D has been obtained as shown in Fig. 9. This figure shows the distribution of verapamil concentration across skin without metabolism. This simulation has been utilized to determine the effective skin thickness ( $h_e$ ) in order to use this value as an input parameter for the previous simulations which mimic the transdermal delivery of verapamil using microneedles. However, the distribution of verapamil concentration across skin with metabolism has not been presented since the concentration profile of both cases (i.e., with and without metabolism) are almost the same as shown previously in Fig. 8. During the injection of microneedles, the drug molecules are assumed to move through an isotropic media which is consistent with many previous works (e.g., Davis, 2003). The detailed explanation of FEMLAB has been avoided in this paper due to brevity of the paper and since they were explained in our other work (Davidson et al., 2008; Al-Qallaf et al., 2009).

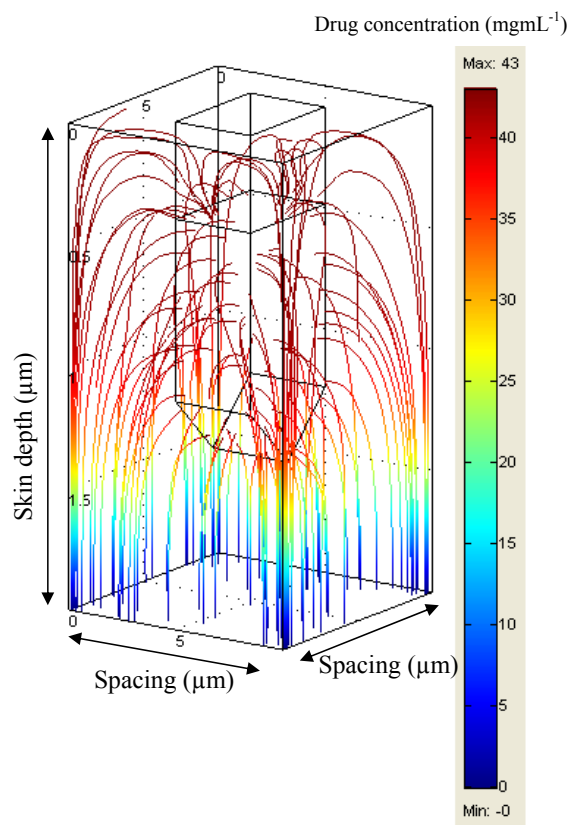

Fig.9. Distribution of verapamil across skin without metabolism in 3D of the microneedle model. (the length 135μm refers to the penetrated length of the microneedle, i.e. the length of the microneedle that has inserted into the skin, due to the property of the skin, the full length of the microneedle will not insert. The length of microneedle is 160 μm and the upper 0.5μm length of the microneedle is the uncoated length of the microneedle that has inserted into the skin.

All together, our result implies that the degree of skin metabolism effect is common patch (case one) > common patch (case two) > microneedles. This result indicates that skin metabolism will greatly influence the transdermal delivery of verapamil in the skin including the diffusion barrier (i.e., stratum corneum) and will not influence so much when the diffusion barrier is bypassed and the diffusion path length of the viable epidermis decreases. This conclusion accords well with the results conducted by Boderke et al (2000). The results obtained from the group's experiment indicated that skin metabolism is connected with epidermal residence time, and this influenced the effect of metabolism on transdermal drug delivery. It has been shown here that the path length is much less using microneedles as compared to when the patch is placed on the skin surface. Hence a shorter epidermal residence time, which justifies the results of the numerical simulation showing that the when using microneedles the effect of skin metabolism is almost eliminated. To sum up, the findings indicate that not only the transdermal delivery of verapamil using microneedles has been improved but also the influence of skin metabolism has been reduced as compared with the transdermal delivery using common patch.

## CONCLUSION

In recent years, microneedle arrays have been shown as one of the most promising technologies to deliver drugs across skin. However, more evaluations are needed to identify its usage for a medical application. One of these issues that should be examined clearly is the implication of drug metabolism in the skin on drug delivery by the microneedles. In this work, verapamil has been used as a model drug to simulate the influence of skin metabolism for microneedles. The mono-layer and bi-layer skin diffusion models have been used to allow us to determine the effects of skin metabolism for all the cases of transdermal delivery of verapamil. The simulated results suggested that verapamil metabolism in the skin had a lower effect on the blood concentration in case of the patch applied on the top of viable epidermis and consequently in case of microneedle systems. These also supported our previous assumption of not considering drug metabolism in the skin for the process of transdermal drug delivery using microneedles (Al-Qallaf and Das, 2009a; Al-Qallaf and Das, 2009b; Davidson et al, 2008; Al-Qallaf et al, 2007). On the other hand, the skin metabolism should be considered for the transdermal delivery of verapamil by applying a patch on the top of the stratum corneum. This mathematical modelling could be useful to design the microneedle systems of the drug metabolized in the skin.

## REFERENCES

Ahmed, J.H., Elliott, H.L., Meredith, P.A., Reid, J.L. "Low-dose verapamil in middle-aged and elderly patients with angina pectoris: No evidence of increased susceptibility to the cardiac effects". *Cardiovascular Drugs and Therapy*, 1992, 6, 153-158.

Al-Qallaf B., Das D. B., Mori D., Cui Z. F., "Modelling Transdermal Delivery of High Molecular Weight Drugs from Microneedle Systems", *Philosophical Transactions of the Royal Society A*, 2007, 365, 1861, 2951-2967.

Al-Qallaf B., Das D. B., "Optimization of Square Microneedle Arrays for Increasing Drug Permeability in Skin", *Chemical Engineering Science*, 2008, 63, 9, 2523-2535.

Al-Qallaf B., Das D. B., "Optimizing Microneedle Arrays to Increase Skin Permeability for Transdermal Drug Delivery", *Annals of the New York Academy of Sciences*, 2009a, 1161, 83-94.

Al-Qallaf B., Das D. B., "Optimizing Microneedle Arrays for Transdermal Drug Delivery: Extension to Non-square Distribution of Microneedles", *Journal of Drug Targeting*, 2009b, 17(2), 108-122.

Al-Qallaf, B., Das, D.B., Davidson, A. "Transdermal drug delivery by coated microneedles: Geometry effects on drug concentration in blood". *Asia-Pacific Journal of Chemical Engineering*, 2009, doi:10.1002/apj.353 (in press).

Amsden B. G., Goosen M. F. A., "Transdermal Delivery of Peptide and Protein Drugs: an Overview", *AIChE Journal*, 1995, 41, 8, 1972-1997.

Anderson P., Bonderson U., Sylvén C., "Clinical Pharmacokinetics of Verapamil in Patients with a Trial Fibrillation", *European Journal of Clinical Pharmacology*, 1982, 23, 1, 49-57.

Auton T. R., "Concentration-Flux Relations for a Multicellular Biological Membrane with Metabolism", *Mathematical Biosciences*, 1993, 115, 1, 103-117.

Bando H., Sahashi M., Yamashita F., Takakura Y., Hashida M. "In vivo evaluation of acyclovir prodrug penetration and metabolism through rat skin using a diffusion/ bioconversion Model". *Pharmaceutical Research*, 1997, 14, 1, 56-62.

Bertera, F.M., Mayer, M.A., Opezzo, J.A.W., Taira, C.A., Hocht, C. (2008) "Comparison of different pharmacodynamic models for PK-PD modeling of verapamil in renovascular hypertension". *Journal of Pharmacological and Toxicological Methods*, 2008, 57, 212-219.

Biocom Systems Inc., "SKIN-CAD<sup>®</sup>, Simulator for Skin Pharmacokinetics", 2006, Fukuoka, Japan.

Boderke P., Schittkowski K., Wolf M., Merkle H. P., "Modeling of Diffusion and Concurrent Metabolism in Cutaneous Tissue", *Journal of Theoretical Biology*, 2000, 204, 393-407.

Bando H., Sahashi M., Yamashita F., Takakura Y., Hashida M., "In Vivo Evaluation of Acyclovir Prodrug Penetration and Metabolism Through Rat Skin Using a Diffusion/ Bioconversion Model", *Pharmaceutical Research*, 1997, 14, 1, 56-62.

Choi D. H., Shin W. G., Choi J. S., "Drug Interaction between Oral Atorvastatin and Verapamil in Healthy Subjects: Effects of Atorvastatin on the Pharmacokinetics of Verapamil and Norverapamil", *European Journal of Clinical Pharmacology*, 2008, 64, 5, 445-449.

Comsol AB, "FEMLAB<sup>®</sup> 3 multiphysic modelling; Documentation", 2005, Stockholm, Amsterdam.

Davidson A., Al-Qallaf B., Das, D. B., "Transdermal Drug Delivery by Coated Microneedles: Geometry Effects on Effective Skin Thickness and Drug Permeability", *Chemical Engineering Research and Design*, 2008, 86, 11, 1196-1206.

Davis, S.P. "Hollow microneedles for molecular transport across skin". Ph.D. thesis, 2003, Georgia Institute of Technology, USA.

Eichelbaum M., Somogyi A., Unruh G. E. V., Dengler H. J., "Simultaneous Determination of the Intravenous and Oral Pharmacokinetic Parameters of D,L-Verapamil Using Stable Isotope-labelled Verapamil", *European Journal of Clinical Pharmacology*, 1981, 19, 2, 133-137.

Godin B., Touitou E., "Transdermal Skin Delivery: Predictions for Humans from in Vivo, ex Vivo and Animal Models", *Advanced Drug Delivery Reviews*, 2007, 59, 11, 1152-1161.

Hadgraft J., "Theoretical Aspects of Metabolism in the Epidermis", *International Journal of Pharmaceutics*, 1980, 4, 229-239.

Higuchi, W.I., Gordon, N.A., Fox, J.L., Ho, N.F.H., "Transdermal delivery of prodrugs". *Drug Development and Industrial Pharmacy*, 1983, 9(4), 691-706.

Hikima, T., Maibach, H.I., Tojo, K. "Skin enzymes distribution in transdermal drug delivery". *The Annual AIChE Meeting*, 2006, San Francisco, USA.

Lipscomb, J., Poet, T.S. "In vitro measurements of metabolism for application in pharmacokinetic modelling". *Pharmacology & Therapeutics*, 2008, 118, 82-103.

Khafagy E., Morishita M., Onuki Y., Takayama M., "Current Challenges in non Invasive Insulin Delivery Systems: a Comparative Review", *Advanced Drug Delivery Reviews*, 2007, 59, 15, 1521-1546.

Kimura, C., Tojo, K. "Development of a stick-type transdermal eyelid delivery system of ketotifen fumarate for ophthalmic diseases". *Chem. Pharm. Bull.*, 2007, 55(7), 1002-1005.

Koike Y., Shimamura K., Shudo I., Saito H., "Pharmacokinetics of Verapamil in Man", *Research Communications in Chemical Pathology and Pharmacology*, 1979, 24, 1, 37-47.

Lee A. J., King J. R., Rogers T. G., "a Multiple-Pathway Model for the Diffusion of Drugs in Skin", *IMA Journal of Mathematics Applied in Medicine & Biology*, 1996, 13, 2, 127-150.

Liu, P., Higuchi, W.I., Ghanem, A.H., Bergstrom, T.K., Good, W.R. "Quantitation of simultaneous diffusion and metabolism of  $\beta$ -estradiol in hairless mouse skin: Enzyme distribution and intrinsic diffusion/metabolism parameters". *International journal of Pharmaceutics*, 1990, 64, 7-25.

Lv, Y. G., Lie, J. & Xu, B., "Modeling of Transdermal Drug Delivery with a Microneedle Array", *Journal of Micromechanics and Microengineering*, 2006, 16, 2492-2501.

McAllister D. V., Wang P. M., Davis S. P., Park J. H., Canatella P. J., Allen M. G., Prausnitz M. R., "Microfabricated Needles for Transdermal Delivery of Macromolecules and Nanoparticles: Fabrication Methods and Transport Studies", *Proceedings of the National Academy of Science*, 2003, 100, 24, 13755-13760.

Michel T., Brunton L. L, Lazo J. S and Pharker KC Eds., “Treatment of Myocardial Ischemia”, “The Pharmacological Basics of Therapeutics”, 2006, Goodman & Gilmans, McGraw-Hill, New York, 11<sup>th</sup> ed.

Mori D., Kawamata H., Tojo K., “Drug Concentration-Time Profile in the Plasma Following the Dissolution-Type Transdermal Delivery”, *Journal of Chemical Engineering of Japan*, 2003, 36, 1, 45-48.

Papa, J., Marton, S., Suvegh, K., Zelko, R. “The influence of metolose structure on the free volume and the consequent metoprolol tartrate release of patches”. *International Journal of Biological Macromolecules*, 2009, 44, 6-8.

Prodduturi, S., Smith, G.J., Wokovich, A.M., Doub, W.H., Westenberger, B.J., Buhse, L. “Reservoir based fentanyl transdermal drug delivery systems: Effect of patch age on drug release and skin permeation”. *Pharmaceutical Research*, 2009, 26(6), 1344-1352.

Sato K., Mine T., “Analysis of in Vitro Rat Skin Permeation and Metabolism of SM-10902, Prodrug of Synthetic Prostacyclin Analogue”, *International Journal of Pharmaceutics*, 1996, 1-2, 135, 127-136.

Schaefer H., Zesch A., Stuttgen G., “Skin Permeability”, Chapter 3, 1982, Springer-Verlag, New York.

Scheidler M. D., Meiselman M., “Use of Verapamil for the Symptomatic Treatment of Microscopic Colitis”, *J Clin Gastroenterol*, 2001, 32, 4, 351–352.

Shah H. S., Tojo K., Chien Y. W., “Transdermal Controlled Delivery of Verapamil: Characterization of in Vitro Skin Permeation”, *International Journal of Pharmaceutics*, 1992a, 86, 2-3, 167-173.

Shah H. S., Tojo K., Chien Y. W., “Development and Clinical Evaluation of a Verapamil Transdermal Delivery System”, *Journal of Controlled Release*, 1992b, 22, 2, 125-132.

Shah H. S., Tojo K., Chien Y. W., “Transdermal Controlled Delivery of Verapamil: Determination of in Vitro/in Vivo Relationship”, *Journal of Controlled Release*, 1992c, 22, 2, 133-140.



Shakeel, F., Baboota, S., Ahuja, A., Ali, J., Shafiq, S. "Accelerated stability testing of celecoxib nanoemulsion containing cremophor-EL". *African Journal of Pharmacy and Pharmacology*, 2008, 2(8), 179-183.

Simon L., Weltner A. N., Wang Y., Michniak B., "a Parametric Study of Iontophoretic Transdermal Drug-Delivery Systems", *Journal of Membrane Science*, 2006, 278, 1-2, 124-132.

Simonetti I., Trivella M. G., Michelassi C., Parodi O., De Nes D.M., L'abbate A., "Dose Response Scrutiny of Coronary Vasodilation After Intracoronary Verapamil in Man. a Quantitative Cineangiographic Study", *European Heart Journal*, 1986, 7, 10, 848-858.

Sugibayashi K., Hayashi T., Morimoto Y., "Simultaneous transport and metabolism of ethyl nicotinate in hairless rat skin after its topical application: the effect of enzyme distribution in skin", *Journal of Controlled Release*, 1999, 62, 1-2, 201-208.

Syvanen, S., Hooker, A., Rahman, O., Wilking, H., Blomquist, G., Langstrom, B., Bergstrom, M., Udenaes, M.H. "Pharmacokinetics of P-Glycoprotein inhibition in the rat blood-brain barrier". *Journal of Pharmaceutical Sciences*, 2008, 97(12), 5386-5400.

Tobin J., Flitman S., "Cluster-Like Headaches Associated With Internal Carotid Artery Dissection Responsive to Verapamil. Headache", *The Journal of Head and Face Pain*, 2008, 48, 3, 461-466.

Tojo K., "Mathematical Models of Transdermal and Topical Drug Delivery", 2005, Biocom Systems Inc, Japan, 2<sup>nd</sup> ed.

Tojo K., "Mathematical Model of Iontophoretic Transdermal Drug Delivery", *Journal of Chemical Engineering in Japan*, 1989, 22, 5, 512-518.

Tojo K., "Mathematical Modelling of Transdermal Drug delivery", *Journal of Chemical Engineering in Japan*, 1987, 20, 3, 300-308.

Tojo, K., Hikima, T. "Bioequivalence of Marketed Transdermal Delivery Systems for Tulobuterol". *Biol. Pharm. Bull.*, 2007, 30(8), 1576-1579.

Tojo, K., Yamada, K., Hikima, T. "Diffusion and metabolism of prednisolone farnesylate in viable skin of the hairless mouse". *Pharmaceutical Research*, 1994, 11(3), 393-397.

Tojo K., Valia K. H., Chotani G., Chien Y. W., "Long-Term Permeation Kinetics of Estradiol: (IV) a Theoretical Approach to the Simultaneous Skin Permeation and Bioconversion of Estradiol Esters", *Drug Development and Industrial Pharmacy*, 1985, 6-7, 11, 1175-1193.

Trewet C. B., Ernst M. E., "Resistant Hypertension: Identifying Causes and Optimizing Treatment Regimens", *Southern Medical Journal*, 2008, 101, 2, 166-173.

Yamaguchi, K., Mitsui, T., Yamamoto, T., Shiokawa, R., Nomiya, Y., Ohishi, N., Aso, Y., Sugibayashi, K. "Analysis of in vitro skin permeation of 22-Oxacalcitriol having a complicated metabolic pathway". *Pharmaceutical Research*, 2006, 23(4), 680-688.

Yamaguchi, K., Mitsui, T., Aso, Y., Sugibayashi, K. "Structure-permeability relationship analysis of the permeation barrier properties of the stratum corneum and viable epidermis/dermis of rat skin". *Journal of Pharmaceutical Sciences*, 2008, 97(10), 4391-4403.

Yamashita F., Hashida M., "Mechanistic and Empirical Modeling of Skin Permeation of Drugs". *Advanced Drug Delivery Reviews*, 2003, 55, 9, 1185-1199.

Yu C. D., Fox J. L., Ho N. F., Higuchi W.I., "Physical model evaluation of topical prodrug delivery simultaneous transport and bioconversion of vidarabin-5'-valerate II: parameter determinations", *Journal of Pharmaceutical Sciences*, 1979, 68, 11, 1341-1346.