



This item was submitted to Loughborough's Institutional Repository (<https://dspace.lboro.ac.uk/>) by the author and is made available under the following Creative Commons Licence conditions.



CC creative commons
COMMONS DEED

Attribution-NonCommercial-NoDerivs 2.5

You are free:

- to copy, distribute, display, and perform the work

Under the following conditions:

BY: **Attribution.** You must attribute the work in the manner specified by the author or licensor.

Noncommercial. You may not use this work for commercial purposes.

No Derivative Works. You may not alter, transform, or build upon this work.

- For any reuse or distribution, you must make clear to others the license terms of this work.
- Any of these conditions can be waived if you get permission from the copyright holder.

Your fair use and other rights are in no way affected by the above.

This is a human-readable summary of the [Legal Code \(the full license\)](#).

[Disclaimer](#) 

For the full text of this licence, please go to:
<http://creativecommons.org/licenses/by-nc-nd/2.5/>

AN AIR SOURCE HEAT PUMP MODEL FOR OPERATION IN COLD HUMID ENVIRONMENTS

L.A. Steijger⁽¹⁾, R. Buswell⁽²⁾, V. Smedley⁽³⁾, S. K. Firth⁽²⁾ and P. Rowley⁽¹⁾

⁽¹⁾ Centre for Renewable Energy Systems Technology, University of Loughborough, Loughborough, United Kingdom

⁽²⁾ Department of Civil and Building Engineering, University of Loughborough, Loughborough, United Kingdom

⁽³⁾ East Midlands Renewable Energy Ltd, Derby, United Kingdom

1. ABSTRACT

There is considerable interest in the use of heat pumps as a potential low-carbon alternative to fossil fuel-based domestic space heating and hot water systems. In many cases, heat pumps are combined with other energy sources such as solar thermal and/or electric resistive heating, to ensure that building thermal loads can be met, and in order to minimise carbon emissions from such integrated systems. Whilst meeting the comfort demands in the occupied space, relatively complex control strategies are required in comparison to simple thermostatic control typically implemented to control gas fired heating systems in domestic buildings. Well characterised models of the principal components of these systems are required to explore and identify the most appropriate strategies in simulation. However, models of air source heat pumps (ASHPs) operating in humid climates, such as the UK, are limited. This paper presents an experimental setup designed to capture the operation of the ASHP in conditions similar to those found throughout a typical heating season in the UK. Results from a number of tests on a 10kW ASHP are presented in terms of the coefficient of performance (COP) and the steady-state operation are used to develop a model using empirical curve fitting. The overall maximum time constant is also established. The resulting model calculates COP as a function of air humidity, air temperature on the evaporator side and water temperature on the condenser side.

Key words: Air source heat pumps, empirical model

2. INTRODUCTION

Simulations can be used to study the performance of various physical system or component configurations in order to identify suitable values for control parameters that aim to reduce running time, reduce energy consumption and minimise operating costs (Fu et al, 2003). The identification of appropriate control strategies is increasingly important for domestic systems that have two or more sources of heat generation. Well defined and realistic models of the key components, of which ASHP's are one, is essential. ASHP's offer great advantages in terms of cost and a reduction in installation time, but a disadvantage is that by using external air as the heat source, makes them sensitive to the prevailing air condition. In humid climates such as the UK it is common to observe close to saturation conditions for significant periods during the heating season, which results in partially or fully wet coil operating conditions. In colder periods this can lead to frost formation on the evaporation coil, to prevent excessive frost build up the ASHP must run from time to time in reverse, to free the air-side coil of ice. The identification of these characteristics has been the focus of the work described in the paper, this work was carried out in order to develop a model that more correctly reflects the likely operating conditions for an ASHP in a cold humid environment.

The paper presents the test set up, data from a series of tests performed on a 10kW domestic packaged ASHP unit. A model is developed that describes the ASHP operation for approximately 70% of typical heating seasons in the midlands of the UK.

3. MODELLING HEAT PUMPS

Existing literature describes approaches for the development of heat pump performance models. One such approach for heat pump performance simulation involves characterising the operation in terms of the underlying physics of the processes in each of the individual components, i.e. the compressor, condenser, expansion valve and evaporator. The simultaneous solution of the equations describing mass, momentum and heat-balance equations, thermodynamic and thermo-physical property relationships and heat or work transfer relationships needs to be executed to generate an output from the model (Welsby et al, 1988). The governing equations take the form of ordinary differential equations in dynamic models, compared with algebraic equations used in steady-state modelling (Ahrens et al, 1983). System variables such as refrigeration mixture, compressor efficiency and the refrigerant flow through the heat exchangers, however, have a great influence on the overall performance of a heat pump and are difficult to model. The result is that first-principle based modelling of heat pumps is complex, error prone and of limited practical use (Heap et al, 1979).

Another approach is to treat the heat pump as a ‘black box’, modelling the internal thermodynamic and heat transfer processes implicitly in the relationship (Morrison et al. 2004). Taking the empirical data and fitting a mathematical curve to this is one such approach, and has been proven effective for modelling heat pumps. A key parameter for assessing heat pump operation in heating mode is the COP. This is defined as the ratio of the amount of heat output (in this case heating of water) to the energy input, in this case the electrical energy used to drive the refrigerant pump. In an ASHP the heat source is the ambient air, the driving power is electricity and the heat is transferred to water in the heat distribution circuit. The variables of each of these components are listed in Table 1. Not all of these variables need to be explicitly modelled since many have little impact on the COP and therefore can be neglected, simplifying the resulting solution.

Table 1: Required variables for ASHP modelling.

Air inlet properties	Electrical properties	Water outlet properties	Time constants
Inlet temperature of the air	Voltage	Inlet temperature	Starting up time constant
Outlet temperature of the inlet air	Current	Outlet temperature	De-freezing time constant
Air Humidity of the inlet air	Frequency	Flow rate	Heat transfer time constant
Air Humidity of the outlet air	Power factor	Density	
Flow rate through the evaporator		Specific heat capacity	
Wind regime over the heat pump (angle and speed)			

3.1. SELECTION OF INLET AIR PARAMETERS

The air inlet temperature is a key parameter used for the characterisation of ASHP. A simple model as used by Andre et al (2008) that models the temperature difference between the cold air inlet and the hot water output. According to Heap et al (1979) air humidity has an influence on the performance of an air source heat pump; if the temperature on the evaporator is above freezing, the latent heat from the condensing air moisture will increase the performance. However, if the temperature of the evaporator coil is below freezing, ice will collect eventually closing off the flow around the evaporator fins. Chen et al (2009) studied the influence of the air humidity and recorded a 10% fluctuation in COP with an air humidity variation of 65 to 90%: Freezing of the evaporator coil was stated as the main reduction in performance. The inclusion of air humidity as an input parameter is therefore critical when modeling ASHP performance in locations with a high prevalence of excessive humidity at low ambient temperatures.

If we assume that the air is not re-circulated, the air leaving the heat pump has no influence on the heat pump anymore and hence has no bearing on the performance of the heat pump. Exhaust air parameters like the temperature and humidity are assumed to have no influence on the performance. In practical operation, in confined spaces this might not be the case, but installation recommendations should limit this type of circulation.

The flow rate through the evaporator coil, is considered to be constant. In a real installation the evaporator coil will experience the collection of, dust, pollen, leaves, etc on the air-side coil surface (Pak et al, 2003), which could have a detrimental effect on the performance. The effects of variable wind velocity (Yao et al, 2004) can also influence performance, but these issues are beyond the scope of the work reported here.

3.2. ELECTRICAL PARAMETERS

The heat pump is controlled through on/off switching of the compressor, and as such is representative of the most commonly installed ASHP units used for domestic applications. ASHP's are electrically driven and the input electrical supply is assumed here to be a nominal 230V at 50Hz. It is recognised that to accurately calculate the COP of the heat pump, the time varying characteristics of the input power need to be determined precisely, this necessitates an accurate power factor measurement. As partial loading of heat pumps using frequency inverters for the compressor becomes more common, the voltage frequency and/or the partial load factor will need to be included (Bettanini et al, 2003).

3.3. WATER OUTLET PARAMETERS

The heat on the condenser side of the heat pump is transferred into a fluid (typically water) via a heat exchanger. Here the water is not mixed with antifreeze or other liquids, and so the relevant properties are taken to be: density, 998 kg/m³, expansion coefficient, 0.21 x10⁻³/°C and specific heat $c_p = 4.1855$ kJ/kg°C @ 25°C. The heat transferred to the waterside can be evaluated using equation 1:

$$Q = \rho V c_p \Delta T \quad (1)$$

Where ρ is the density, V is the volume, c_p is the specific heat capacity and ΔT the temperature difference between the water inlet and water outlet temperature. Variations in density and specific heat are considered to be negligible over the range of temperatures experienced during normal operation. The heat transferred into the water on the condensing side is determined by the heat exchanger configuration and operating conditions. The heat transfer on the refrigerant side is given by equation 2.

$$Q = \rho V \Delta h_{\text{vap}} \quad (2)$$

with Δh_{vap} the specific latent heat of evaporation. From (1) with a given heat output Q , a set flow rate V and a constant density and specific heat, either the heat distribution loop outlet or inlet temperatures are required to determine the temperature difference over the evaporator coil.

Water mass flow rate through the heat exchanger is also important, particularly if the flow rate is sufficiently low such that it is laminar, this will have a significant impact on heat transfer coefficient.

3.4. SYSTEM TIME CONSTANTS

The aspects discussed above are the static parameters of a heat pump. To generate optimised control, the time constants within the system also need to be known, especially the start-up time

constant. This is the time between starting the heat pump and the output power reaching 63% of its end value with all other parameters fixed.

Another performance related time constant is the duration between defrost cycles. This time constant is dependent on the temperature and the air humidity. As stated previously, Chen et al (2009) recorded the time between defrost cycles as a function of the air humidity and temperature.

The third time constant relates to the heat capacity of the heat pump coils. If the flow is varied within the coil, there could be a delay in temperature variation due to the heat capacity of the heat exchanger within the ASHP.

From the above discussion the focus of the simulation will be on the temperature and humidity on the evaporator coil/air inlet side of the ASHP, the water in, outlet temperature and the flow rate of the water in the condenser side of the heat pump. Time constants, especially the starting up time, also need to be established.

4. EXPERIMENTAL SET-UP

The test rig as shown in Figure 1 was built up in an environmental chamber. Water was connected to the ASHP via a three way valve (Valve1) and a water mass flow controlling two way valve (Valve2). A pump provided the necessary flow for circulation. The water outlet temperature ($T_{w,out}$) at the condenser is controlled by adjusting the water mass flow rate (Valve2). The condenser water inlet temperature ($T_{w,in}$) can be controlled by mixing the warm water from the outlet with the cold external feed (Valve1). A bypass valve placed in parallel with Valve2 ensures a minimum flow rate. The flow is measured with a calibrated oval gear flow meter, with an accuracy of $\pm 0.5\%$ of the maximum flow. The power that the air pump consumed under standard conditions was 2.5 kW. (compressor and fan)

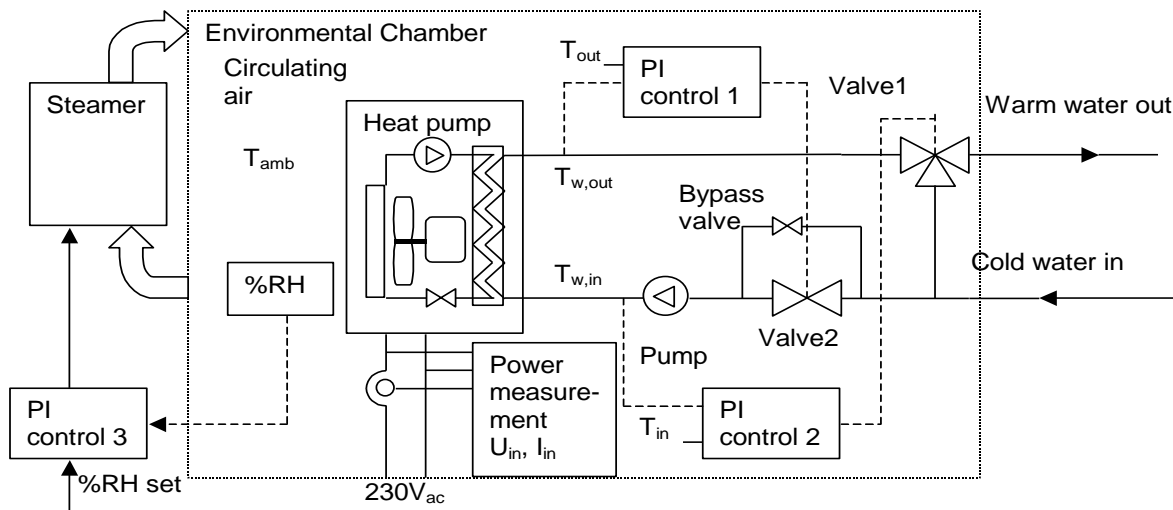

Figure 1: Schematic model of the Test rig.

The principle of the test is based on defining a starting temperature and air humidity, within the chamber, and then letting the ASHP run cooling the chamber down and thus varying the inlet air temperature on the evaporator side. The tests are started at an air temperature of 15°C and tests verified that the rate of change in air temperature was slow compared to the time constants of the ASHP, and so the test measurements can be considered to be made at, or close to, steady-state. Air humidity is maintained at the desired value by adding steam via a steam humidifier in the supply air duct to the chamber.

Temperatures are measured using PT1000 elements to DIN EN 60751 Class Y. The maximum error on the temperature measurements is calculated at ± 0.2 °C. Humidity is measured to $\pm 3\%$ and the power measurements (voltage, current and power) to an error of $\pm 0.5\%$.

4.1. THE TEST SERIES

The range of each of the driving environmental input variables on the air-side needs to be determined. For the U.K., CIBSE gives guidance on average temperature and air humidity, but not in correlation to each other over a heating season. If a heating hour is defined as when the ambient temperature is less than 15°C, an estimate of the heating season can be made using weather data from the nearest geographically located weather station. Weather data from Sutton Bonnington airfield was obtained, applying above 15°C limit it can be calculated that for 72.2% of the heating season period, the air temperature is between 2°C and 15°C with a humidity of higher than 75%.

Since the heat pump COP decreases with increasing temperature difference between ambient air temperature and the hot water set point, the heating flow temperature ($T_{w, out}$) in the dwelling should be as low as possible: A flow temperature ($T_{w, out}$) of 35 °C to 50°C has been assumed. The return flow into the heat pump ($T_{w, in}$) will under normal operating conditions be approximately 10 °C – 20 °C lower than the feed temperature. The volumetric flow rate in domestic water based heating system is normally between 0.05 and 0.5 litres/second.

A series of tests were developed to characterise this region of operation. Each of the following test were run for ambient air temperatures through the range 15°C down to 2°C:

COP as a function of the air humidity: The air humidity was controlled at 85% RH, 90% RH and 100% RH. The water outlet temperature ($T_{w, out}$) at the condenser is set at 40°C and the water inlet temperature ($T_{w, in}$) to the condenser heat exchanger was held constant at 20°C. The data was used to generate the curves for the dependency on the air humidity.

COP as a function of the condenser outlet water temperature: The outlet water temperature ($T_{w, out}$) after the condenser heat exchanger is controlled at 40°C, 45°C and 50°C. The air humidity is kept constant at 90% RH and the inlet temperature ($T_{w, in}$) to the condenser heat exchanger is set at 20°C. This data has been used to generate the standard COP curves of the heat pump.

COP as a function of the inlet water temperature ($T_{w, in}$): The inlet water temperature was controlled at 20°C, 25°C and 30°C, the air humidity was set at 90%RH and the outlet temperature was set at 45°C. From this set of measurements the dependency on the inlet temperature has been determined.

4.2. MEASURED DATA

Data was collected every 10 seconds and each test was approximately 5 hours in duration (the time it takes to cool the room from 15°C to 2°C). Figure 2 depicts data from one test: The ambient air can be seen to change at a rate of approximately 1 degree every 20 minutes. The plot shows noise on the calculated COP that can be attributed to the condenser water inlet flow regulation in order to maintain the inlet and outlet temperature settings. The fluctuation in the air humidity is a result of the used steamer, once the internal overflow was full, a drain and a following automatic refill sequence resulted in a slight fluctuation of the air humidity.

As the two control loops interact with each other, to obtain stability, the output temperature control was set within a time constant of 1 minute control, the control for the inlet temperature was set at 10 minutes. As extra heat was added to the test chamber at start to maintain a slow decrease in temperature, as the test series continued, this heat was switched off manually if the temperature did not decrease for more than 0.1 °C in 10 minutes. As a result, some step changes in the temperature and COP are visible in the curves. (around 11:30 and 13:00)

The COP has been calculated for each of the test series. To do this using the quasi-steady data, the ambient air temperature was used to calculate bin samples that fell into sequential bins of 1°C,

from 15°C down to 2°C. The data for each variable was averaged according to the samples that fell into each bin, and these were used in the analysis to represent the steady-state performance characteristics of the ASHP.

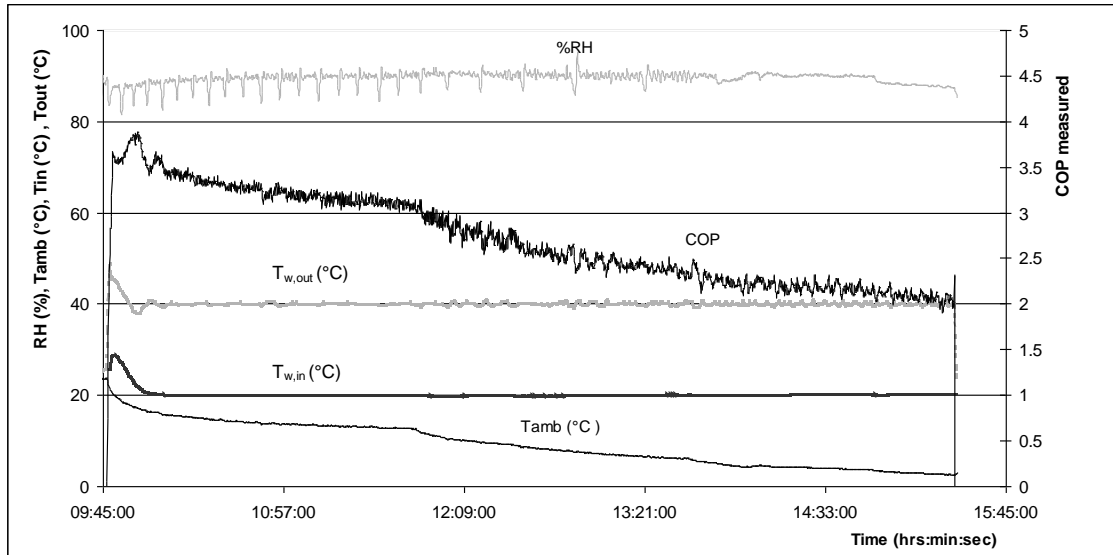

Figure 2: data from one of the test series. On the left axis from top to bottom the %RH, outlet water temperature, inlet water temperature and the ambient air temperature. On the right axis the calculated COP of the heat pump.

5. RESULTS

For each of the test series the results are presented and discussed. Appropriate models from the literature are then identified and applied to sequentially build up a new model for ASHP operation in cool, humid environments.

5.1. COP AS A FUNCTION OF THE AIR HUMIDITY

Three test series were conducted and the results plotted in Figure 4. Note that the limitations of the environmental test chamber resulted in the 100% humidity test series ceasing at 6°C: The steam humidifier, prevented a further reduction in temperature while maintaining 100% saturation.

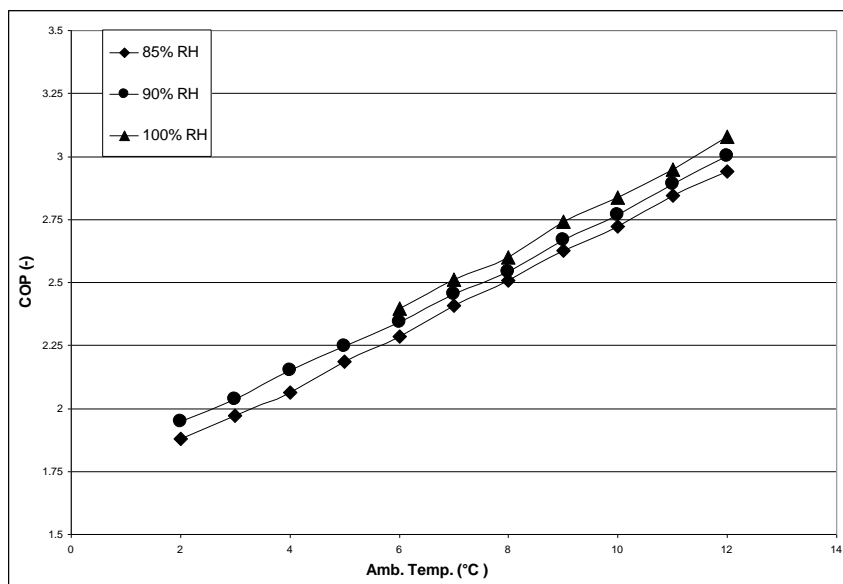

Figure 3: COP as a function of the air humidity. The outlet water temperature was controlled to 40 °C, the inlet water temperature controlled at 20 °C, The ambient temperature varied between 14 and 2 °C.

Figure 3 shows the dependence of COP on ambient air temperature, and a weaker, but not insignificant dependence on air humidity. The coil was operating in at least partially wet conditions during the test, and so further tests are required to determine dry coil operation. It was noted during the test that the exhaust air was measured to be close to saturation throughout most of the test period.

5.1.1. Model development

The model used by Morrison et al (2004) (Equation 3) uses input variables air inlet temperature and humidity, and a formula to link the two. It uses a linear equation to link the ambient air T_{amb} with the outlet water temperature $T_{w,out}$. It does not, however, give values of the system parameters a_1 to a_3 :

$$COP = (a_1 + a_2(T_{w,out} - T_{amb})) (1 - a_3 (T_{amb} - T_{wetbulb}) / (T_{amb} - T_{dewpoint})) \quad (3)$$

When calculating a value for constant a_3 for the relationships shown in Figure 3 it was found that the solution for a_3 varies between $2.2 < a_3 < 4$, with an ambient air temperature range of between 2°C and 14°C . Therefore this approach was rejected due to the large variation.

Another approach is to take the viewpoint from an evaporation dynamics point of view. It was noted that the exhaust air was saturated. We hence could assume that the evaporator coil was covered in moisture and air was blowing over it. As such the evaporator coil is operating in a similar state as the wick in the wet bulb measurement, i.e. a balance between the condensation and evaporation on a wet surface. So if the (dry bulb) air temperature is compensated for the air moisture content by the same amount as the difference in dry and wet bulb temperature, the COP model is compensated for the air humidity. Or with other words, if the input for the model is not the dry bulb, but the wet bulb temperature, not only the ambient (dry bulb) temperature, but also the air humidity is automatically incorporated into the model.

Lawrence (2005) derived a simple approximation for a correlation of the dew point and the air humidity for air humidity's higher than 50%:

$$T_d = T_{amb} - (100 - \%RH) / 5 \quad \text{or} \quad T_{amb} - T_d = (100 - \%RH) / 5 \quad (4)$$

In the measurement range of 2°C and 14°C and air humidity higher than 80%, the factor between the wet bulb depression and the dew point depression ranges from approximately 1.5 to 2.5. Assuming the average of 2, the depression is:

$$T_{amb} - T_{wetbulb} = \Delta T_{rh} = - (100 - \%RH) / 10 \quad (5)$$

With the air humidity changing from 85% to 100 %, the temperature difference caused by the air humidity ΔT_{rh} caused an effective ambient air temperature increase of 1.5°C . This is confirmed by our measurement results. So the measurements confirm that instead of using the dry bulb temperature for calculating the COP, for high air humidity's, the wet bulb temperature is more appropriate as input value for the model. If only the relative humidity is known, the wet bulb temperature can be calculated using equation (5).

So at high air humidifies ($>85\%$), using the wet bulb temperature instead of the dry bulb temperature compensates for the air humidity in this experiment.

5.2. COP AS A FUNCTION OF THE CONDENSER OUTPUT WATER TEMPERATURE

The results are shown in Figure 4. There is a significant dependency on the temperature difference between the air temperature and the condenser water output temperature. As the temperature difference between the air temperature T_{air} and the water outlet $T_{\text{w,out}}$ increases, the COP decreases, confirming the characteristics observed in most of the relevant literature.

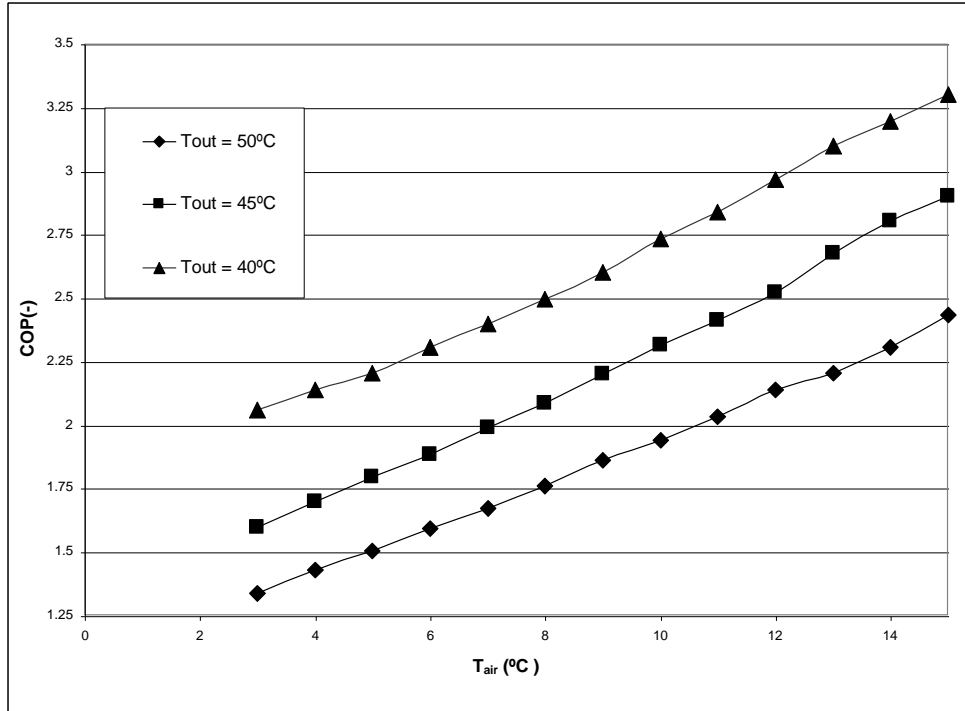

Figure 4: COP as function of the ambient temperature and condenser water outlet temperature.

Baek et al (2005) already formulated an equation with the temperature dependencies (using the wet bulb and outlet water temperature as the effective temperatures):

$$\text{COP} = a_0 + a_1 T_{\text{wet bulb}} + a_2 T_{\text{wet bulb}}^2 + a_3 T_{\text{w,out}}^2 + a_4 T_{\text{w,out}} + a_5 T_{\text{wet bulb}} T_{\text{w,out}} \quad (6)$$

with a_0 to a_5 system constants, depending on the heat pump.

Using these graphs and equation 5, a numerical solution generates the relationship between the COP on one side and the wet bulb temperature $T_{\text{wet bulb}}$ and the water temperature $T_{\text{w,out}}$ on the other side of the equation. As the polynomial equation used by Baek et al (2005) is quadratic the highest term has been assumed quadratic for the equations. With a $T_{\text{w,out}}$ of 40°C the polynomial describing the curve is:

$$\text{COP} = 0.0021 T_{\text{wet bulb}}^2 + 0.069 T_{\text{wet bulb}} + 1.82 \quad (7)$$

Similar for $T_{\text{w,out}} = 45^\circ\text{C}$ and 50°C :

$$\text{COP} = 0.0018 T_{\text{wet bulb}}^2 + 0.072 T_{\text{wet bulb}} + 1.36 \quad (8)$$

$$\text{COP} = 0.0009 T_{\text{wet bulb}}^2 + 0.073 T_{\text{wet bulb}} + 1.12 \quad (9)$$

With these three equations we have a relationship between the coefficients with the only variable the output temperature. An equation can be established for the quadratic term, the linear term and the constants. If we use the three points to fit a curve for the output temperature, we can determine the coefficients for this heat pump:

$$\begin{aligned} \text{COP} = & \left\{ -1.2 \cdot 10^{-5} T_{w,\text{out}}^2 + 9.6 \cdot 10^{-4} T_{w,\text{out}} - 0.017 \right\} T_{\text{wet bulb}}^2 \\ & + \left\{ 0.0003 T_{w,\text{out}} + 0.057 \right\} T_{\text{wet bulb}} \\ & + \left\{ 0.0043 T_{w,\text{out}}^2 - 0.46 T_{w,\text{out}} + 13.3 \right\} \end{aligned} \quad (10)$$

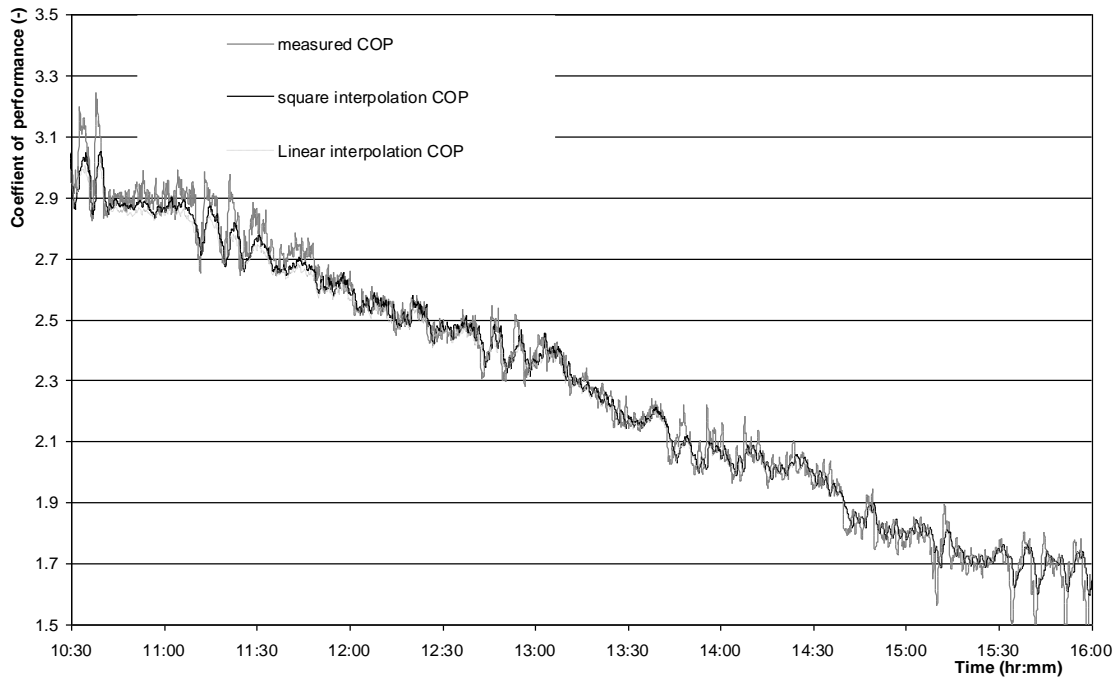

Figure 5 The difference of a square polynomial interpolation and a linear interpolation for the quadratic term is negligible for this heat pump. The quadratic interpolation is slightly better with higher $T_{\text{wet bulb}}$ and $T_{w,\text{out}}$

It has two extra terms comparing with Baek et al (2005). These extra terms are the result of a polynomial interpolation on the quadratic term of the equation. A constant would have resulted in the same formula as Baek et al (2005) and the differences between the two methods is negligible as shown in Figure 5.

Combining (4) and (9) it is possible to check the measured data against the computed model. The result is shown in Figure 6. Although the instantaneous error peaks at 10%, the moving average over 60 periods (10 minutes) after start-up is below 2.5 %. This is due to the fast control of the flow for the instantaneous value, whereas the model is based on the temperatures only, which have a time lag as shown in the next paragraph.

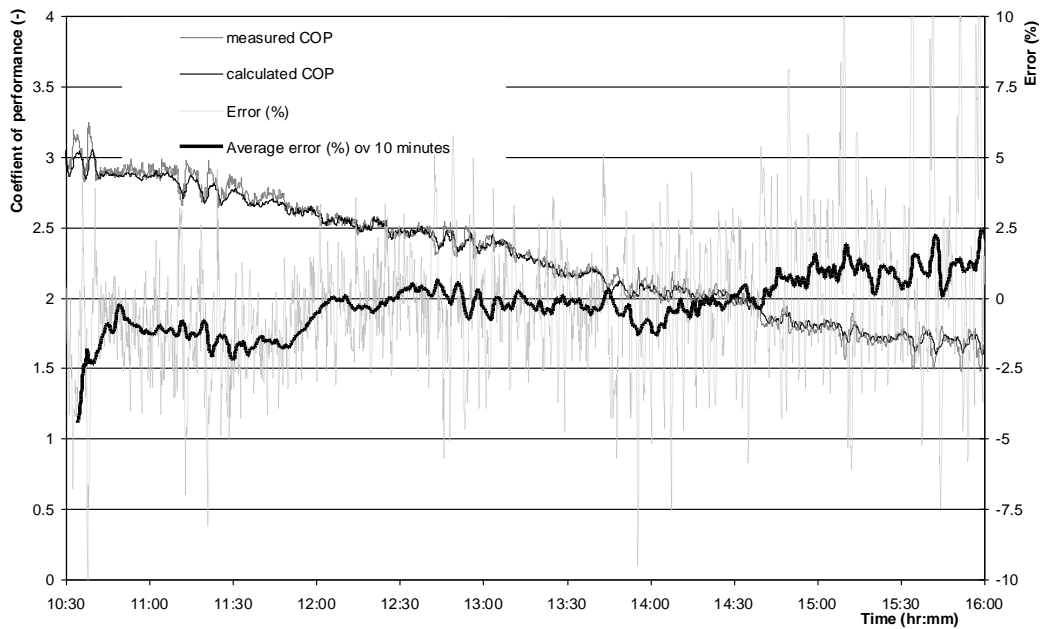

Figure 6 Comparison of the model with the real values. As the instantaneous error is peaking at 10% due to the fast control of the flow rate, the rolling average error averaged over 60 samples is less than 2.5 % after start-up.

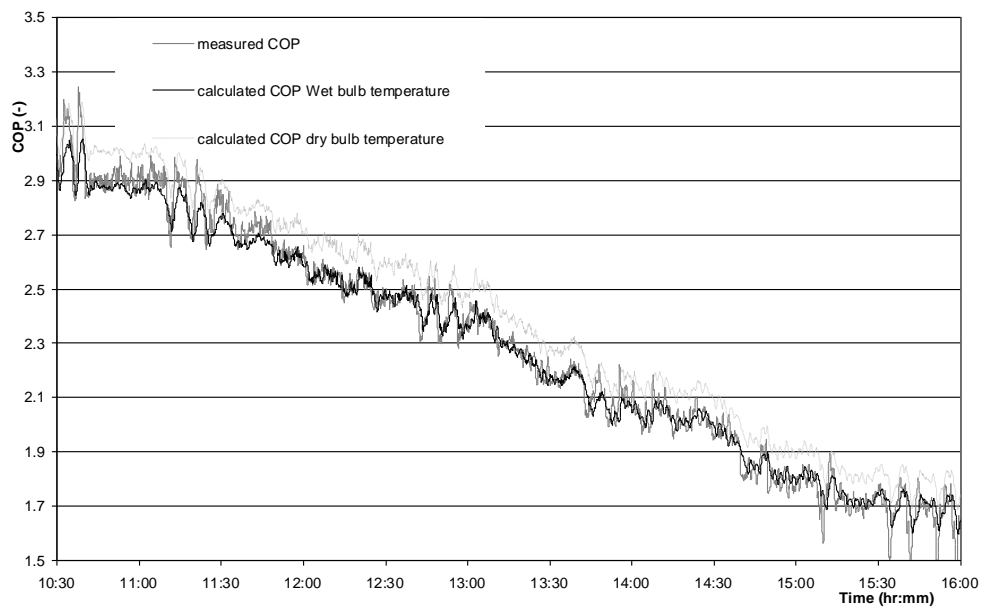

Figure 7 Comparison of the model with the difference in using the dry and wet bulb temperature. Using the dry bulb temperature creates an offset between the real measured COP and the calculated COP in the model.

Figure 7 shows the influence of the air humidity. If the normal ambient temperature is used, the COP follows a curve just above the more accurate curve using the wet bulb temperature.

The advantage of the new model is that it combines the findings of Baek with a compensation for the influence of the air humidity. This results in an error less than 2.5 % in an average over 60 samples.

5.3. COP AS A FUNCTION OF CONDENSER WATER INLET TEMPERATURE

Figure 8 shows no major influence of the condenser inlet temperature on the performance on the COP. However, the plot demonstrates that the flow rate through the water heat exchanger is fully turbulent. The flow rate changes from 0.14 l/s with an inlet temperature of 30°C and ambient temperature of 15°C to 0.04 l/s with an ambient temperature of 2°C and an inlet temperature of 20°C. The outlet temperature was controlled to 45 °C. If there was an influence from the flow rate, the graphs would not overlay each other and disperse at a low flow rate if the flow was to change from turbulent to laminar. It was observed that there was a drop in heat transfer as the flow rate dropped below 0.01 l/s, which was attributed to the onset of laminar flow in the water side of the condenser heat-exchanger.

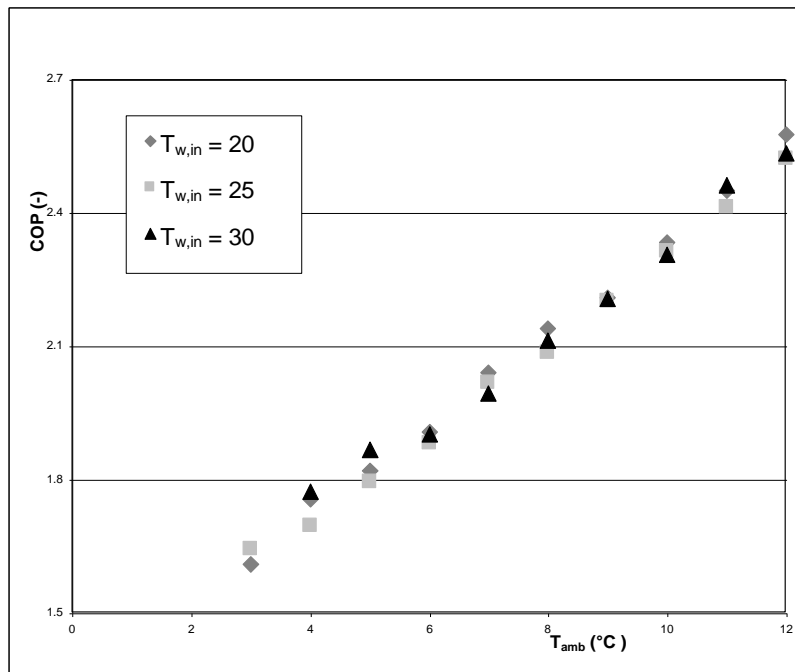

Figure 8: COP as function of the condenser water inlet temperature. Outlet temperature was held constant at 45, flow rate of the water was modulated, inlet temperature between 12 and 3 °C.

5.4. TIME CONSTANT OF HEAT PUMP

To establish if a heat pump can be modelled with a steady-state simulation or dynamic modelling is necessary, the time constants of the heat pump need to be known. If the time constants are much less (<100 times) than the steady-state running time of the heat pump, the error will be less than 1 %, can be ignored. If the time constants are >100 times the steady state of the heat pump, the error cause by this will be larger, and has to be taken into consideration. As the heat pump under test has a constant compressor speed, the time constant of switching the unit on and the heat output need to be established.

Figure 9 shows the input current and the output temperature during switch on. The heat output shows similarity with a first order system and a time constant between approx. 30 to 40 seconds.

If the running time of this heat pump is much larger than the time constant of the heat pump (assume time step of simulation >100 times the time constants of the heat pump i.e. between 3000 and 4000 seconds). The error due to the start up time can be neglected as the start-up time is 40 seconds and is therefore negligible when compared with the heat pump running time.

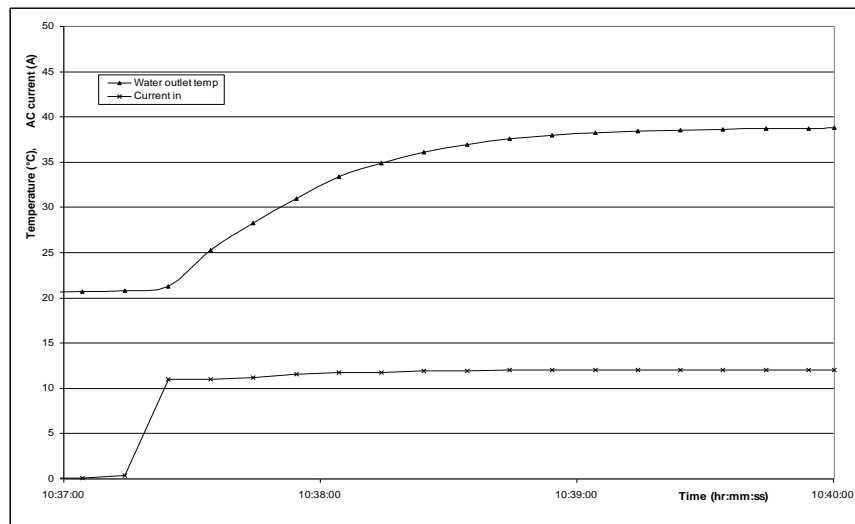

Figure 9 Switching on time constant of the heat pump. The time constant between switching on the heat pump and generating heat out is approximately 40 seconds.

The control for the flow rate is run on a 10 second cycle, well within the time constant of the heat pump. This is the reason for the relative large instantaneous error between the model and the measurements.

6. CONCLUSION

To develop control strategies and parameters settings, modelling is a useful tool. However, the results of the simulation are as good as the models used. This paper looked into all the relevant parameters and confirmed, albeit with different equations, the previous studies. A new empirical model, combining the findings of Baek et al (2005) and Morrision et al (2004) and time constants have been established for one heat pump, and the error over a rolling average of 60 samples (which equates 10 minutes) is less than 2.5% of the measured values. This model, in its present form, needs to be refined. More empirical data comparisons need to be made, particularly with different types of heat pumps and lower air humidity's. The model may then be used to conduct a full parametric implementation of heat pumps for developing control and optimisation strategies. In addition, expansion of the model is to consider inverter driven heat pumps, the effect of clogging up the evaporator coil and/or defrosting need to be researched, and for a more accurate dynamic model, transients and start-up influences needs to be developed. More research is hence necessary to obtain an universal air source heat pump model.

References:

- Ahrens, F. W., 1983, "Heat pump modeling, simulation and design", Heat Pump Fundamentals.
- Andre, P., Georges, B., Lebrun, J., Lemort, V., Teodorese, I.V., 2008 "From model validation to production of reference simulations: how to increase reliability and applicability of building and HVAC simulation models", Building Serv. Eng. Res. Technol. 29, 1
- Bettanini, E., Gastaldello, A., Schibuola, L., 2003, "Simplified models to simulate part load performances of air conditioning equipments", Eighth International IBPSA Conference, Eindhoven.
- Baek, N.C., Shin, U.C., Yoon, J.H., 2005, "A study on the design and analysis of a heat pump heating system using wastewater as a heat source", Solar Energy, Volume 78, Issue 3.

Chen, Y.-g., Guo, X.-m., Yang, Z., 2009, "Dynamic defrosting characteristics of air source heat pump and effects of outdoor air parameters on defrost cycle performance", Applied Thermal Engineering, Volume 29, Issue 13.

CIBSE guide 1986, The Chartered Institute of Building Engineers, London

Fu, L., Ding, G., Zhang, C., 2003, "Dynamic simulation of air-to-water dual-mode heat pump with screw compressor", Applied Thermal Engineering 23

Heap, R.D., 1979 *Heat Pumps* 2nd ed. E&F Spon Ltd, London.

Incropera, F.P., and DeWitt, D.P., 2006. *Fundamentals of Heat and Mass Transfer*. 6th ed. John Wiley & Sons, Hoboken, NJ.

Mark G. Lawrence, 2005, "The Relationship between Relative Humidity and the Dewpoint Temperature in Moist Air: A Simple Conversion and Applications", Bulletin of the American Meteorological Society

Morrison, G.L., Anderson, T., Behnia, M., 2004, "Seasonal performance rating of heat pump water heaters", Solar Energy 76.

Pak, B.C., Baek, B.J., 2003, "Impacts of Fouling and Cleaning on the Performance of Plate Fin and Spine Fin Heat Exchangers", KSME International Journal, Vol. 17.

Welsby, P., Devotta, S., Diggory, P.J., 1988, "Steady- and Dynamic State Simulations of Heat Pumps. Part I: Literature Review", Applied Energy 31.

Yao, Y., Jiang, Y., Deng, S., Ma, Z., 2004 "A study on the performance of the airside heat exchanger under frosting in an air source heat pump water heater/chiller unit", International Journal of Heat and Mass Transfer 47