

PPAD 9/33/39

Quality and field of
vision - a review of the
needs of drivers and
riders

Phase 1 Report

Undertaken on behalf of

The Department of the Environment,
Transport and the Regions

Prepared by

Dean Southall

Sharon Cook

Richard Tait

Claire Quigley

July 1999

Contents

1.	
Introduction.....	1
2. Interested parties.....	2
2.1 The current positions of interested parties.....	2
2.2 Trends in motorcycle ownership.....	4
2.3 Visor sales.....	5
3. Directives, Regulations and Standards.....	6
3.1 Vehicle glazing.....	6
3.1.1 ISO Standard 3537, ECE Regulation No. 43 and Council Directive 92/22/EEC.....	6
3.1.2 Scope:.....	6
3.1.3 General specification:.....	6
3.1.4 Definitions of glazing types:.....	6
3.1.5 Structural and testing requirements.....	7
3.1.6 Optical quality testing and abrasion resistance.....	10
3.1.7 EEC type-approval markings.....	17
3.2 Automotive windscreen repair.....	18
3.2.1 BS AU 242a:1998 - Code of practice.....	18
3.2.2 Scope.....	18
3.2.3 General specification.....	18
3.2.4 BS AU 251:1994 - Performance.....	20
3.2.5 Scope.....	20
3.2.6 Definitions.....	20
3.2.7 Testing.....	20
3.2.8 M.O.T. Inspection Manual - Windscreens.....	21
3.2.9 Reason for rejection.....	21
3.3 Motorcycle helmet visors.....	22
3.3.1 ECE regulation No. 22 (<i>Incorporating 05 series of amendments - draft proposal</i>) and British Standard BS 4110:1999.....	22
3.3.2 Scope:.....	22
3.3.3 General specification:.....	22
3.3.4 Definitions:.....	23

3.3.5 Optical quality testing and scratch resistance.....	25
3.4 Motorcycle goggles.....	31
3.4.1 BS EN 1938:1999.....	31
3.4.2 Scope.....	31
3.4.3 General specifications - Optical requirements.....	31
3.4.4 Optical test methods.....	31
3.5 Rationale for existing optical quality approval values.....	37
3.6 Drivers' field of vision - A-pillar obscuration.....	37
3.6.1 Council Directive 77/649/EEC.....	37
3.6.2 Scope.....	37
3.6.3 General specification.....	37
3.6.4 Definitions.....	39
4.	
Research.....	41
4.1 Rider Vision.....	41
4.1.1 The Function of Visors and Goggles.....	41
4.1.2 Abrasions.....	42
4.1.3 The use of tinted visors in daylight.....	42
4.1.4 The use of tinted visors at night.....	43
4.1.5 Tinting vs Abrasions.....	44
4.1.6 Coloured Lenses.....	46
4.1.7 Visors - Safe Practice.....	46
4.1.8 Visors - Subjective Opinions.....	47
4.1.9 Other Aspects which may affect visual acuity through visors.....	47
4.1.10 Conclusions to rider vision.....	48
4.2 Drivers vision.....	49
4.2.1 Tinting.....	49
4.2.2 Justification for reduced tinting levels.....	49
4.2.3 Justification for not reducing tinting levels.....	51
4.2.4 General findings.....	58
4.2.5 Haze and Abrasion.....	59
4.2.6 Abrasion.....	60
4.2.7 Reflectance.....	65
4.2.8 Screen bands.....	65
4.2.9 A-Pillar Obstructions.....	66
4.2.10 Conclusions to driver vision.....	68
4.3 Alternatives and new developments.....	69
4.3.1 Alternatives.....	69
4.3.2 New developments.....	70
4.3.3 Water and dirt resistant windscreens.....	71
5. Accident data.....	72
5.1 STATS 19.....	72
5.2 TRL fatals database.....	72
5.3 The Glasgow database.....	72
5.4 South Yorkshire Police AIB.....	73
6. Interviews with drivers and riders.....	74
6.1 Car driver experiences and opinions.....	75

6.1.1	Windscreen misting.....	75
6.1.2	Windscreen cleaning.....	75
6.1.3	Sun glare.....	76
6.1.4	Tinted windows.....	76
6.1.5	A-pillar obscuration.....	76
6.1.6	Summary - drivers.....	77
6.2	Rider Experiences and Opinions.....	78
6.2.1	Summary findings.....	79
6.2.2	Misting.....	79
6.2.3	Glare.....	79
6.2.4	Changing from tinted to clear visors when visibility declines.....	80
6.2.5	Alternatives to tinted visors.....	80
6.2.6	Abrasion.....	81
6.2.7	Summary - riders.....	81
7.	Plan for Phase 2.....	82
7.1	Surveys.....	82
7.1.1	Windscreen rake survey.....	82
7.1.2	Windscreen damage/repair survey.....	82
7.1.3	Windscreen haze survey.....	83
7.1.4	Windscreen abrasion survey.....	83
7.1.5	Visor usage survey.....	83
7.1.6	A-pillar survey.....	83
7.2	Quality of vision trials.....	84
7.2.1	Variables - visor/goggle trials.....	85
7.2.2	Variables - windscreen trials.....	85
7.2.3	Methodology.....	86
7.2.4	Outputs.....	87
7.3	Field of view (A-pillar) trials.....	87
7.3.1	Variables.....	88
7.3.2	Methodology.....	88
7.3.3	Outputs.....	90
7.4	Proposals and costings.....	90
7.5	Amendments to legislation and enforcement practices.....	90
7.6	Final report.....	92
7.7	Work plan.....	92
7.7.1	Scheduling.....	92
7.7.2	Items for consultation.....	93
8.	References.....	95
9.	Appendices.....	98
9.1	Appendix 1. Contacts.....	98
9.2	Appendix 2. Driver vision survey data.....	101
9.3	Appendix 3. Motorcyclists eye protection survey data.....	109

1. Introduction

It is the responsibility of the Department of the Environment, Transport and the Regions (DETR) to promote safe use of the UK road network. Driver vision has been identified as major determinant to this and factors which impede it require further investigation.

This project is specifically concerned with the effect on driver / rider vision of:

- windscreen and visor tinting, installed light transmission, haze, abrasion, damage and repair,
- the use and positioning of wider structural member (particularly A-pillars) to improve crashworthiness, aerodynamics and rigidity.

The first phase of the work is to understand the current status regarding the above factors and the rationale for it. A variety of sources have been consulted for this information including:

- establishing contact with interested parties,
- reviewing and establishing the basis of EC Directives and other regulations,
- reviewing and summarising previous, current and proposed research,
- analysing available accident data,
- interviewing drivers and riders.

A detailed work plan for the remainder of the project has been developed based on the results of the Phase 1 findings and on the professional experience ICE Ergonomics has in this field.

2. Interested parties

A wide range of individuals and organisations with a specialist interest or expertise related to the scope of the project have been identified. The project team have had direct communications with, members of relevant BSI committees, motorcycling organisations, window tinting companies, visor manufacturers, vehicle glazing companies, test houses and others undertaking research directly relevant to the project. The list of contacts is provided in Appendix 1

The technical and background information so obtained appears in the appropriate sections of this report. Below we summarise the current position of interested parties with regard to the issue of amending the regulations/standards covering the transmission levels of motorcyclists' eye protection.

2.1 The current positions of interested parties

Members of BS PH/2/5, with the exception the DETR, proposed and supported a reduction in the minimum eye protector luminance transmittance from 50% to 18%, known as Filter Category 2 (see Table 2 in the Draft revision to BS 4110, document number 97/540067, dated 9/1/97).

Colin Fowler (Vision Sciences Dept, Aston University) states in a letter to the committee, dated 1st September 1997, that the current 50% transmittance would not protect against sun glare. He cites BS 2724:1987 'Sunglare protectors for

general use' which states that for protection from sunglare while driving, filters should have a transmittance of between 29.1% to 17.8% (the source of this data is not known to us at this time).

Ronald Rabbetts, a practising optometrist and member of the BSI committees PH/2 eye protection and PH/2/1 Sunglasses, contacted ICE to provide information on the theoretical benefits of tinting. A tinted lens, he states, reduces discomfort glare by a factor of its transmittance raised to the power of 0.6. Thus a pale tint with a transmittance of 85% reduces the glare to 0.91 of its previous value, 50% transmittance to 0.65 and 20% (a fairly dark sunglass but in the range allowed by BS EN 1836 for vehicle drivers) to 0.38 of the original glare index. (ICE has yet to re-run these calculations to confirm the conclusion).

The members proposing or supporting this proposal recognised potential safety disbenefits and suggested the following provisos:-

- that Category 2 visors should not be used during darkness or conditions of poor visibility,
- that they should be marked 'For daytime use only' or the equivalent (a draft symbol was circulated for comment:-
- RoSPA considered Category 2 filter acceptable only for riders with good eyesight who did not wear spectacles or contact lenses.
- That it be made a statutory offence under RVLRs to wear a Category 2 visor at night.
- that the means of attaching the visor to the helmets should be manufactured to enable easy fitting and removal without tools to encourage responsible use i.e. changing between 'clear' and tinted as light conditions change.

The DETR, in a letter from Peter O'Reilly (26th Feb. 1998) to BSI, set out in detail their concerns and reasons for opposing Category 2 filters. In summary DETR's objections are based on the lack of any new evidence to suggest that a compelling case can be made on grounds of road safety for a further reduction. A major concern is the issue of potential misuse, i.e. riders using darker visors during darkness and poor visibility. They also point out that when experiencing glare from low sun, the contrast between bright sun and normal light is such that adequate vision can only be achieved by obscuring the sun completely. DETR suggest that this is best solved by using a helmet or visor with a removable peak or perhaps by a visor with a graduated tint. (Bob Heath argues that such graduated visors do not address the issue of glare reflected from the road surface.)

The British Motorcyclists Federation has 130,000 member including affiliates, and over 12,000 individual members. Trevor Magner of the BMF and a member of the BS committee stated that while the BMF is interested in the tinting issue, it is not currently a high priority, campaigning issue. He believes that fogging (misting) is a greater issue than abrasion now that the new BS 4110 standard increases the abrasion resistance requirement. Mr Magner is concerned that anti-fog/mist surfaces may be too soft and vulnerable to scratching (interior surfaces)

and that fogging may be a helmet design issue i.e. ventilation.

2.2 Trends in motorcycle ownership

In 1997 there were 626,000 licensed motorcycles in the UK, compared to 978,000 in 1987 (Transport Statistics Great Britain 1998). Over this ten-year period there has been a significant change in the types of machine owned. In 1987, $\frac{2}{3}$ of licensed machines were under 125cc, in 1997 nearly $\frac{2}{3}$ were over 125cc, with the largest single category being machines over 500cc. (See Table 1)

Table 1. Licensed motorcycles

We can speculate on the possible reasons for this shift in ownership; changes in the motorcycle driving test, fewer people using a motorcycle to commute to work and an increase in the number of older riders returning to motorcycling. The shift to larger machines may contribute to an increased market for tinted visors. The riders of more powerful and faster machines may have more disposable income, seek more ways of increasing their perceived safety and given the high-tech nature of modern motorcycling may seek out the latest technology in their protective equipment.

2.3 Visor sales

Sales figures give an indication of the numbers of different types of visor in use and the demand for tinting. Bob Heath supplied figures for their popular 2mm replacement visors over the last 8 years – 61% clear, 39% smoke (all BS4110ZA certified).

3. Directives, Regulations and Standards

The following chapter is a précis of the legislative literature pertaining to vehicle glazing, windscreen repair and motor cycle helmet visors. It pays particular reference to the visual/optical properties required and the processes of approval testing.

3.1 Vehicle glazing

3.1.1 ISO Standard 3537, ECE Regulation No. 43 and Council Directive 92/22/EEC.

3.1.2 Scope:

‘ . . . applies to safety glazing and materials for glazing intended to be fitted in the form of a windscreen or other glazing or separating panels on motor vehicles and their trailers . . . ‘.

3.1.3 General specification:

‘ . . . safety glazing shall be adequately transparent, cause no noticeable deformation of objects seen through the windscreen, nor cause any confusion between the colours used on road signs. In the event of windscreen breakage the driver must continue to be able to brake and bring his vehicle to a halt in complete

safety'.

3.1.4 Definitions of glazing types:

- glazing:- a pane of glass consisting of a single sheet of glass having undergone a special treatment intended to increase its mechanical strength and to limit its fragmentation when smashed.
- ordinary laminated glass windscreens:- at least two sheets of glass held together by at least one sheet of plastic material that is sandwiched between them, where neither sheet of glass has been treated in such away as to increase its mechanical strength and to limit its fragmentation when smashed.
- treated laminated glass windscreens:- at least two sheets of glass held together by at least one sheet of plastic material that is sandwiched between them, where at least one sheet of glass has undergone a special treatment intended to increase its mechanical strength and to limit its fragmentation when smashed.
- plastic-coated safety glass:- glazing with a coat of plastic material on its inner surface.
- plastic-glass windscreens:- laminated glazing having a single sheet of glass and one or several sheets of plastic laid one on top of the other, at least one of which serves as a sandwich layer. The sheet(s) of plastic is (are) located on the inner surface when the glazing is fitted to the vehicle.
- double glazing:- a unit consisting of two panes assembled at the factory in a permanent manner and separated by a uniform space.
- uniformly toughened glass windscreens:- a glass pane consisting of a single layer of glass which has been subjected to special treatment (*either thermal or chemical*) to increase its mechanical strength and to condition its fragmentation after shattering.

3.1.5 Structural and testing requirements

The ECE Regulation No. 43 and EEC Directive 92/22 provide a description of the apparatus, test conditions and procedure for each of the following mechanical, environmental and optical tests:

3.1.5.1 Mechanical strength

- Fragmentation test:- to verify that the fragments and splinters produced by smashing of the pane of glass are such to minimise the risk of injury and in the case of treated laminated glass windscreens to check residual visibility after shattering.
- 227g ball-impact test:- to assess the adhesion of the inter-layer in laminated glass and the mechanical strength of uniformly toughened glass.
- 2260g ball impact test:- to assess the ability of the laminated glass to resist ball penetration.

- Headform test:- to verify the glass panes compliance with the requirements relating to the limitation of injury in the event of impact of the head against the windscreen.

3.1.5.2 Resistance to the environment

- Abrasion test:- to determine whether the resistance of a safety-glass pane to abrasion exceeds a specified value.
- High-temperature test:- to verify that no bubbles or other defects occur in the inter-layer in a laminated glass or glass-plastics pane when the latter is exposed to high temperatures over an extended period of time.
- Resistance to radiation test:- to determine whether the light transmittance of laminated glass, plastic-glass and plastic-coated glass panes exposed to radiation over an extended period of time is significantly reduced thereby or whether the glazing is significantly discoloured.
- Resistance to humidity test:- to determine whether a laminated-glass, plastic-glass and plastics-coated glass pane will withstand, without significant deterioration, the effects of prolonged exposure to atmospheric humidity.
- Resistance to temperature change test:- to determine whether the plastic material(s) used in safety glazing will withstand, without significant deterioration, the effects of prolonged exposure to extreme temperatures.
- Fire resistance test: to verify that the inner face of a pane of safety glass has sufficiently low burn rate.
- Resistance to chemical agents test:- to determine whether the inner surface of a pane of safety glass will withstand, without significant deterioration, the effects of exposure to the chemical agents likely to be present or used in a vehicle.

3.1.5.3 Optical qualities

- Light transmission test: to determine whether the regular transmission of safety-glass panes exceeds a specified value.
- Optical distortion test: to verify that the distortion of objects as seen through the windscreen is not to such an extent as to be likely to confuse the driver.
- Secondary image separation test: to verify that the angular separation of the secondary image from the primary image does not exceed a specified value.
- Colour identification test: to verify that there is no risk of confusion of colours as seen through a windscreen.

3.1.6 Optical quality testing and abrasion resistance

3.1.6.1 Light transmission testing:

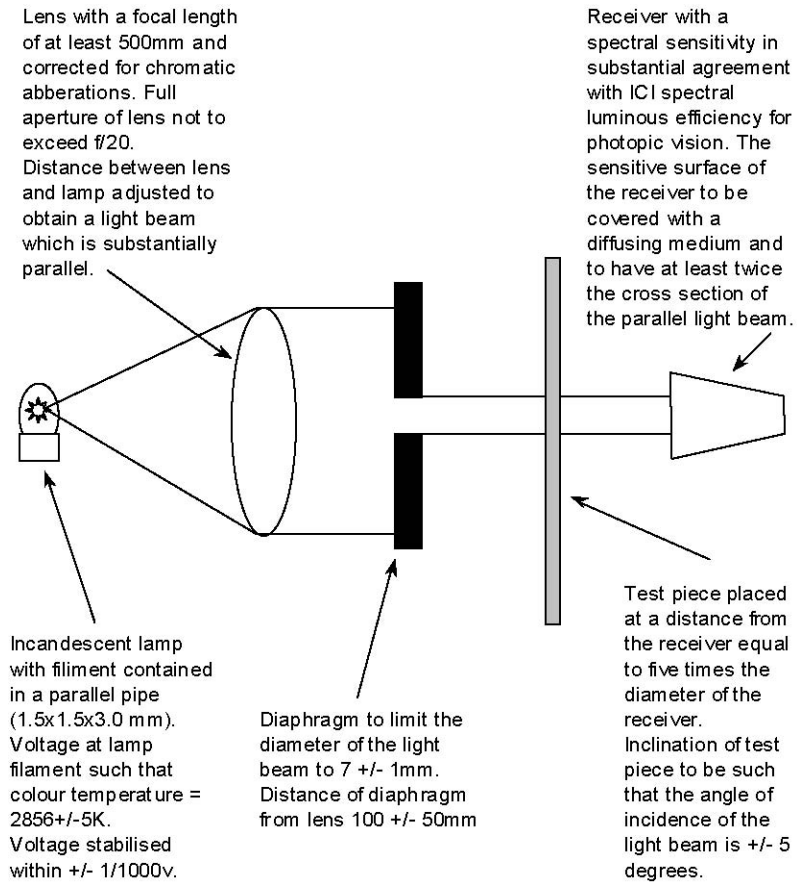

Figure 1. Light transmission measuring apparatus.

The regular transmission measured shall not, in the case of windscreens, be less than 75%

3.1.6.2 Testing the degree of hazing or light scatter due to abrasion

The process and apparatus for testing resistance to abrasion are detailed below.

The abrasive wheels are each 45-50mm in diameter and 12.5mm thick, consisting of a special finely-screened abrasive embedded in a medium-hard rubber. The wheels have a hardness of 72 ± 5 IRHD.

The abrasive wheels are mounted in such a way that each wheel rests on the test specimen under a pressure applied by a mass of 500g. The wheels rotate in opposite directions and exert a compressive and abrasive action along curved lines over an annular area of about 30 square cm.

Test piece mounted on a horizontal turntable (deviation from horizontal plane not to be greater than ± 0.05 mm at a distance of 1.6mm from the turntable periphery) revolving counter-clockwise at 65 to 75 rev/min.

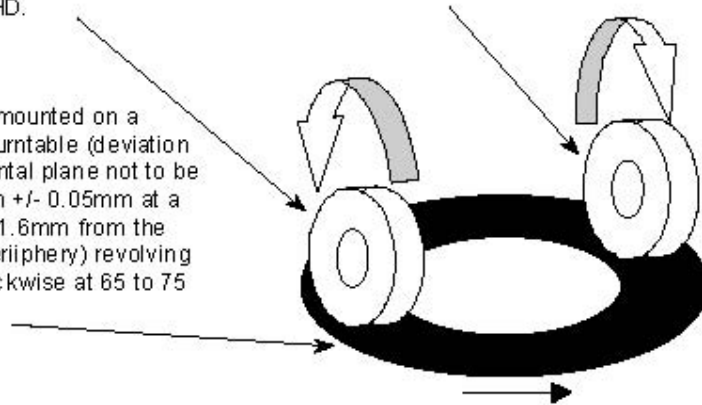

Figure 2. Abrading instrument

The apparatus for measuring the amount of abrasion and subsequent light scatter are detailed below:

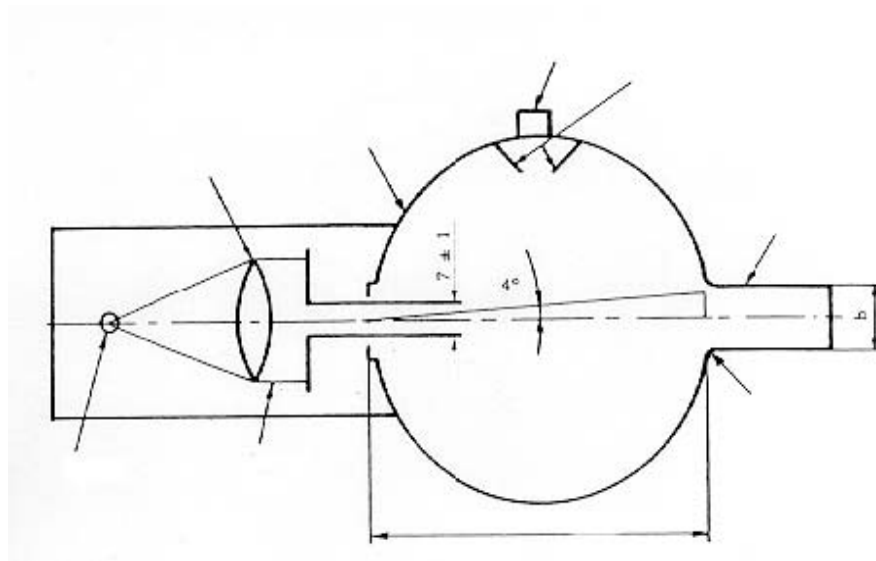

Figure 3. Hazameter- Light transmission test

The hazameter measures light scattered as a result of abrasion on the surface of the test piece. The lamp, voltage, lens and diaphragm are as detailed for the apparatus used in the light transmittance test. The integrating sphere is equipped with entry and exit ports and a photo electric cell mounted in such a way that it cannot be reached by light coming directly from the entrance port. The exit port is provided with a reflectance standard or a light trap which will absorb all the light when no test piece is inserted in the light beam. The interior surface of the integrating sphere and reflectance standard shall be of substantially equal reflectance.

The test conditions are:

- temperature 20 +/- 5 °C
- pressure 860 to 1060 mbar
- relative humidity 60 +/- 20 %
- test pieces conditioned for a minimum of 48 hours

With the test piece mounted immediately against the entrance port of the integrating sphere, four readings are taken as indicated in the following table:

Table 2. Hazameter readings

Repeat the readings for T1, T2, T3 and T4 at four equally-spaced positions on the test piece.

Total transmittance
$$T_t = \frac{T_2}{T_1}$$

Diffuse transmittance
$$T_d = \frac{T_4 - T_3(T_2/T_1)}{T_1}$$

Percentage haze or light scattered
$$\frac{T_d}{T_t} \times 100\%$$

3.1.6.3 Optical distortion test

- Optical deviation:- the angle between the true and apparent direction of a point viewed through the safety-glass pane, the magnitude of the angle being a function of the angle of incidence of the line of sight, the thickness and inclination of the glass pane and the radius of curvature at the point of incidence.
- Optical distortion:- the algebraic difference in angular deviation $\Delta\alpha$ measured between two points M and M' on the surface of the safety glass pane, the distance between the two points being such that their projections in a plane at right angles to the direction of vision are separated by a given distance Δx .

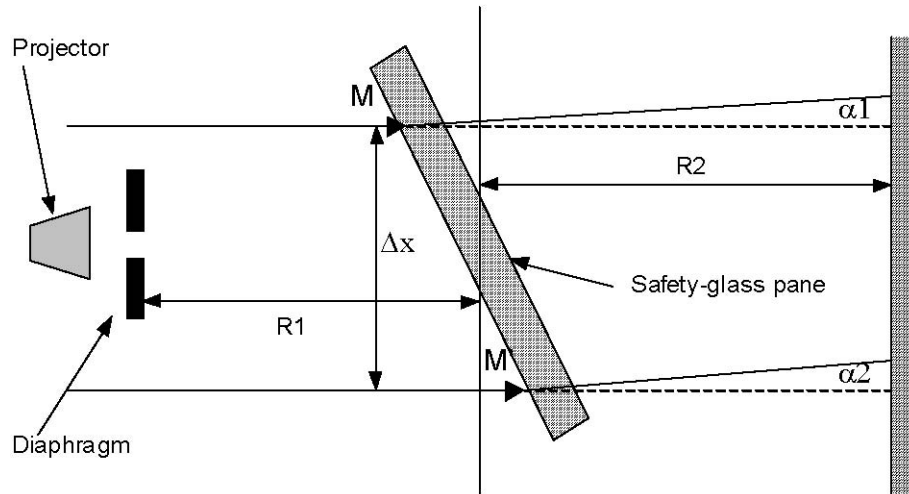

Figure 4. Arrangement of the apparatus - optical-distortion test.

The distortion test entails the projection of an appropriate slide (raster) onto a display screen through the safety glass pane being tested. The change caused in the shape of the projected image by the insertion of the safety glass pane in the line of sight provides a measure of the distortion.

In the absence of the safety glass pane to be examined the dimensions of the circular shape shall be such that when they are projected the circles have a diameter of:

$$\frac{R1 + R2}{R1} \Delta x$$

on the screen, where $\Delta x = 4\text{mm}$ (see Figure 4)

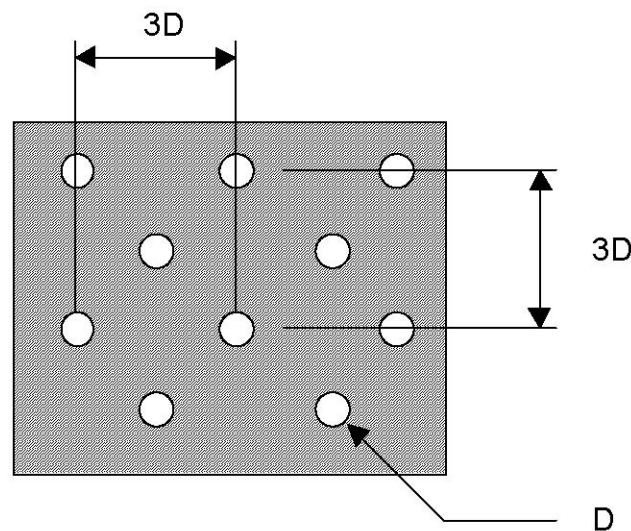

Figure 5. Example of raster slide - optical-distortion test

Where a rapid assessment with a possible margin of error of up to 20% is sufficient, calculate the value of A from the limit value $\Delta\alpha L$ for the change in deviation and the value of R2, for the distance from the safety glass pane to the display screen:

$$A = 0.145\Delta\alpha L \times R^2$$

The relationship between the change in diameter of the projected image Δd and the change in angular deviation $\Delta\alpha$ is given by:

$$\Delta d = 0.29\Delta\alpha \times R^2$$

The type of windscreen shall be considered satisfactory as regards optical distortion if optical distortion does not exceed 2' of an arc in the main zone of the windscreen.

3.1.6.4 Secondary-image separation test

Two test methods are recognised:

- target test
- collimator-telescope test

Target test

This method involves viewing an illuminated target through the safety glass pane. The target shall preferably be one of the following types:

- a) an illuminated ring target whose outer diameter, D , subtends an angle of N minutes of an arc at a point situated at x metres (Figure 6a) or
- b) an illuminated ring and spot target whose dimensions are such that the distance, D , from a point on the edge of the spot to the nearest point on the inside of the ring subtends an angle of n minutes of an arc at a point situated at x metres (Figure 6b).

Where:

n is the limit value of secondary-image separation,

x is the distance from the safety glass pane to the target (not less than 7m)

$$D = x \cdot \tan n$$

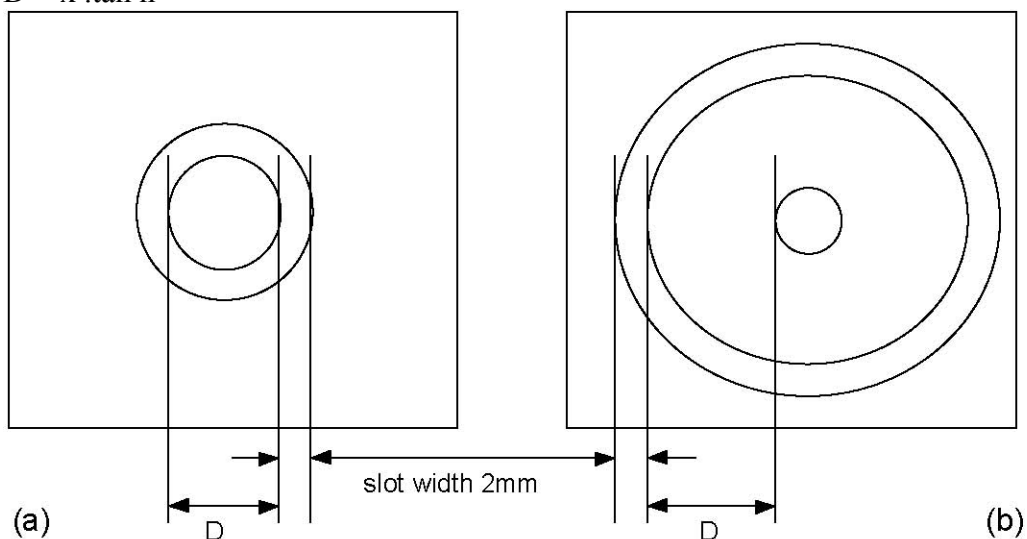

Figure 6. Dimensions of targets - secondary image separation test

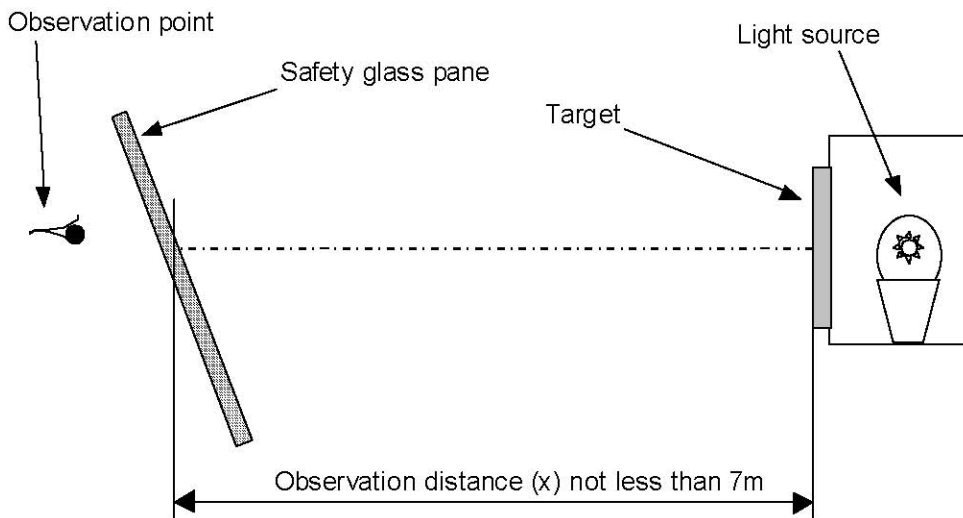

Figure 7. Arrangement of apparatus - secondary image separation test

When the ring target is used, the primary and secondary images of the circle will separate but should not exceed the limit value n .

When the ring spot target is used, the secondary image of the spot shifts beyond the point of tangency with the inside edge of the circle but should not exceed the limit value n .

3.1.6.5 Identification of colours test

When a windscreen is tinted four windscreens shall be tested for identifiability of the following colours:

- white
- selective yellow
- red
- green
- blue
- amber.

3.1.7 EEC type-approval markings

- I made of toughened glass (I/P if it is coated)
- II made of ordinary laminated glass (II/P if it is coated)
- III made of treated laminated glass (III/P if it is coated)
- IV if it is made of plastic glass
- V if this is a pane of glass other than a windscreen
- VI if it is a double glazed unit

3.2 Automotive windscreen repair

3.2.1 BS AU 242a:1998 - Code of practice

3.2.2 Scope

‘ . . . gives recommended practices for repairing laminated windscreens damaged by impacts. It applies to HGVs, coaches and passenger cars.

Recommendations include:

- the type and size of damage that can be repaired
- the area on the windscreen in which repairs of particular types can be made
- procedures for the repairer
- steps to assess the quality of finished repairs
- reports and records for completion and retention by the repairer

3.2.3 General specification

The type and size of damage that can be repaired should be limited as a function of the position of the damage on the windscreen (Table 3 and Figure 8)

Table 3. Windscreen zones and permitted repairs

The MOT test permits repairs to damage in Zone A up to 10mm in diameter and 40mm in all other areas.

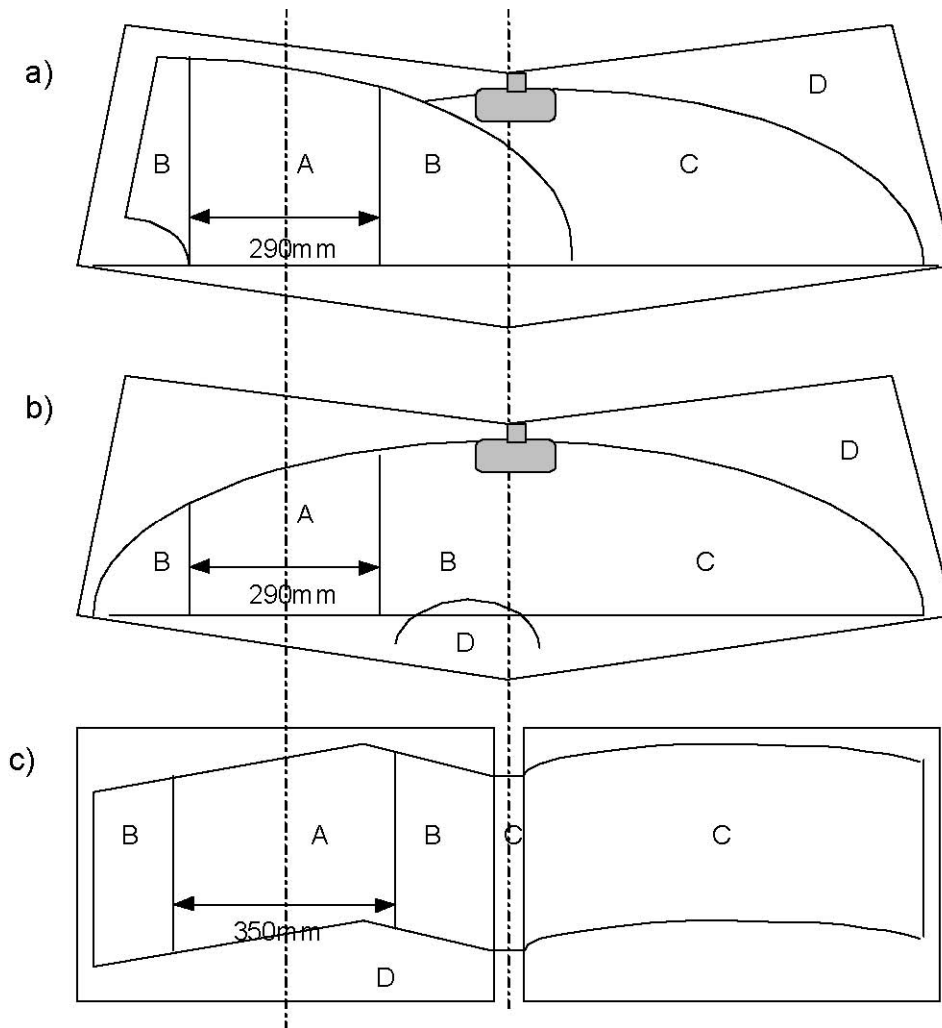

Figure 8. Windscreen repair zones - a) Passenger car with two wipers, b) passenger car with single wiper, c) HGV/Coach with two wipers

The following restrictions regarding the type and size of damage should be complied with:

- damage extending through all layers of glass should not be considered repairable in any area of the windscreen
- damage with a crater at the point of impact exceeding 5mm in diameter should not be considered repairable
- if damage, delamination or irreversible contamination (dirt, water) of the inter-layer has occurred, the windscreen should not be considered repairable

The repairer should inspect the repaired area to ensure it conforms such that:

- repairs should not show significant optical defects. The damaged area should be clear, but small imperfections may be acceptable;
- visual inspections should be carried out from the inside of the vehicle, under good illumination from a distance of 230mm with normal corrected vision;
- if after repair a residual small dull spot is visible in the damaged area, the spot should not exceed 5mm in diameter;
- repaired areas should be free of voids, air bubbles or foreign materials;

- repaired areas should not interfere with windscreen wiper function.

3.2.4 BS AU 251:1994 - Performance.

3.2.5 Scope

‘ . . . specifies performance requirements for the windscreen repair systems, including the materials used, to be employed for the repair of laminated windscreens that have been damaged by impacts’. It is applicable to the repair of HGV, coach and passenger car windscreens.

3.2.6 Definitions

windscreen repair material:- a plastics resin material containing as its essential ingredient an organic substance of high molecular weight which is polymerized during the repair procedure to provide adhesive strength and a colourless, weatherproof transparent filler.

3.2.7 Testing

Each of the resin repair materials supplied with the repair system shall be subjected to the following tests:

- Resistance to humidity
- Resistance to high temperature
- Resistance to radiation
- Visual appearance
- Optical distortion
- Light scatter
- Impact resistance (2260g ball and headform)
- Mechanical strength

3.2.8 M.O.T. Inspection Manual - Windscreens

Repaired windscreens - must be inspected to the same test criteria as original unrepaired windscreens. Repairs must be judged solely on the basis of whether they interfere with vision. An ‘invisible’ or barely detectable repair, finished flush with the surrounding glass, does not count as damage even if it exceeds the limit on damage allowed in the test.

Scratches - scratches on the windscreen, i.e. light surface scratching, is not to be considered damage. However, an area of concentrated scratching such as caused by the prolonged use of a defective wiper blade which obscures vision is to be considered a reason for rejection if it meets the fail criteria.

3.2.9 Reason for rejection

In Zone ‘A’(the swept area of the windscreen in a vertical band 290mm wide, centred on the steering wheel): -

- damage not contained within a 10mm diameter circle
- a windscreen sticker or other obstruction encroaching more than 10mm
- a combination of minor damage areas which seriously restricts the driver’s view

In the remainder of the swept area: -

- damage not contained within a 40mm diameter circle
- a windscreen sticker or other obstruction encroaching more than 40mm

Tinting films are not subject to reason for rejection.

Opaque edging on windscreens is not regarded as part of the windscreen.

3.3 Motorcycle helmet visors

3.3.1 ECE regulation No. 22 (*Incorporating 05 series of amendments - draft proposal*) and British Standard BS 4110:1999.

3.3.2 Scope:

‘ . . . applies to protective helmets for drivers and passengers of mopeds and of motor cycles with or without side-car and to the visors fitted to such helmets or intended to be added to them.

3.3.3 General specification:

. . . . ‘It must be possible to manoeuvre the visor out of the field of vision with a simple movement of one hand. . . .

. . . ‘The surface of the visor in the peripheral field of vision of the helmet may include the lower edge of the visor, provided that it is made of a material with at least the same transmittance as the rest of the visor.

Visors shall have a luminous transmittance $\tau_v \geq 80\%$, relative to the standard illuminant D65. A luminous transmittance $80\% > \tau_v \geq 50\%$, is also permissible if the visor is marked with the symbol shown below and/or with the English words “DAYTIME USE ONLY”. The luminous transmittance shall be measured before the abrasion test.

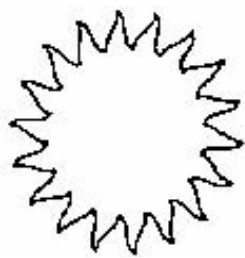

Daytime use only

Visors shall be free from any significant defects likely to impair the vision, such as bubbles, scratches, inclusions, dull spots, holes, mould marks, scratches or other defects originating from the manufacturing process in the field of vision.

Visors shall in addition be sufficiently transparent, shall not cause any noticeable distortion of objects as seen through the visor, shall be resistant to abrasion, resistant to impact and shall not give rise to any confusion between the colour used in road sign and signals. The relative visual attenuation quotient (Q) (*before the abrasion test*) shall not be less than:

0.80 for red and yellow signal lights

0.60 for green signal light
0.40 for blue signal light

3.3.4 Definitions:

- peak:- an extension to the shell of the helmet above the eyes.
- visor:- a transparent protective screen extending over the eyes and covering all or part of the face.
- goggles:- transparent protectors that enclose the eyes
- ocular areas:- two circles of minimum diameter 52mm spaced symmetrically about the vertical centre line of the visor, the distance between the centres of the circles being 64mm measured in the horizontal front plane of the visor as worn.
- luminous transmittance (τ_v)

$$\tau_v = \frac{\int_{380nm}^{780nm} S_{D65\lambda}(\lambda) \cdot V(\lambda) \cdot \tau_F(\lambda) \cdot d\lambda}{\int_{380nm}^{780nm} S_{D65\lambda}(\lambda) \cdot V(\lambda) \cdot d\lambda}$$

- relative visual attenuation quotient (Q)

$$Q = \frac{\tau_{sign}}{\tau_v}$$

where:

τ_v is the luminous transmittance of the visor relative to the standard illuminant D65.

τ_{sign} is the luminous transmittance of the visor relative to the spectral power distribution of the traffic signal light.

τ_{sign} is given by the equation:

$$\tau_{sign} = \frac{\int_{380nm}^{780nm} S_{A\lambda}(\lambda) \cdot V(\lambda) \cdot \tau_F(\lambda) \cdot \tau_S(\lambda) \cdot d\lambda}{\int_{380nm}^{780nm} S_{A\lambda}(\lambda) \cdot V(\lambda) \cdot \tau_S(\lambda) \cdot d\lambda}$$

where:

$S_{A\lambda}(\lambda)$ is the spectral distribution radiation of CIE standard illuminant A (or

3200K light source for blue signal light) See: ISO/CIE 10526, CIE standard colorimetric illuminants.

$S_{D65\lambda}(\lambda)$ is the spectral distribution of radiation of CIE standard illuminant D65. See: ISO/CIE 10526, CIE standard colorimetric illuminants.

$V(\lambda)$ is the spectral visibility function for daylight vision. See: ISO/CIE 10527, CIE standard colorimetric observers.

$\tau_S(\lambda)$ is the spectral transmittance of the traffic signal lens

$\tau_F(\lambda)$ is the spectral transmittance of the visor

3.3.5 Optical quality testing and scratch resistance

A test piece (minimum dimension 50mm x 50mm) is taken from the flattest part of the visor (within a defined area) and undergoes ambient-temperature and hygrometry conditioning. Next it is washed, rinsed and dried before undergoing luminous transmittance and light diffusion testing. After testing it is subjected to an abrasion test before undergoing the light diffusion test again.

3.3.5.1 Luminous transmittance testing.

In a parallel beam, with the test specimens being irradiated vertically, the spectral transmittance values between 380nm and 780nm are determined. The transmittance and visual attenuation quotient can then be calculated from the given formulae. To calculate the luminous transmittance the spectral distribution of the standard illuminant D65 and the spectral values of the colorimetric 2° standard observer CIE 1931 according to ISO/CIE 10256. The product of the spectral distribution (D65) and spectral values of the standard observer is given in Annex 14 of ECE regulation No. 22.

3.3.5.2 Light diffusion testing

There are three methods given in Annex 11 of ECE Regulation No. 22 to measure the light diffusion of visors both before and after the abrasion test. However, for each method ('a', 'b' and 'c') the light diffusion shall not exceed the following values:

Table 4. Visor maximum light diffusion values

For reasons of brevity only method 'a' is described here.

Method 'a'

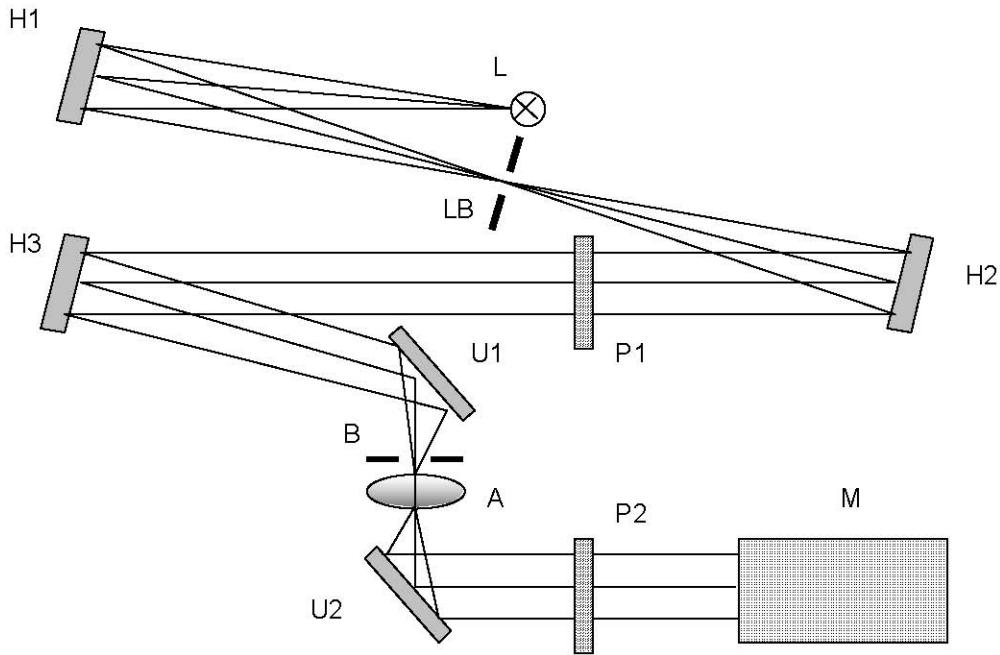

Figure 9. Light diffusion measuring apparatus

- L High pressure Xenon lamp
- H1, H2, H3 Spherical concave mirrors - focal length 150mm, diameter 40mm.
- U1, U2 Flat mirrors
- B Diaphragms - either annular with an outer circle diameter of 21mm and an inner circle diameter of 15.75mm or circular with an aperture diameter of 7.5mm.
- A Achromatic lens with a focal length of 200mm and a diameter of 30mm
- LB Circular diaphragm with an aperture diameter of 1mm
- P1, P2 Positions of visor
- M Silicon detector corrected according to curve $V(\lambda)$ fitted with a diffusing screen.

The above assembly (Figure. 9) collects all the unscattered light originating from the visor up to an angle of 0.72° using the circular diaphragm and all the scattered light between the angles of 1.5° and 2° using the annular diaphragm (This angular area is important in the case of night riding, where a range in the immediate proximity of headlights has to be observed).

The measurements taken are:

Table 5. Light diffusion measurements

$$\text{Luminous transmittance} = \frac{T_{1c}}{T_{0c}} \times 100$$

$$\text{Light diffusion} = 597 \times \frac{(T_{1a} - T_{2a})}{T_{1c}}$$

3.3.5.3 Abrasion test

Three kilograms of 0.5/0.7mm grain size quartz sand is allowed to drop through a gravity tube from a height of 1.65m on to the sample to be tested. The test piece revolves on a turntable, which is mounted at 45° to the gravity tube, at a speed of 250 +/- 10 rpm (Figure 10).

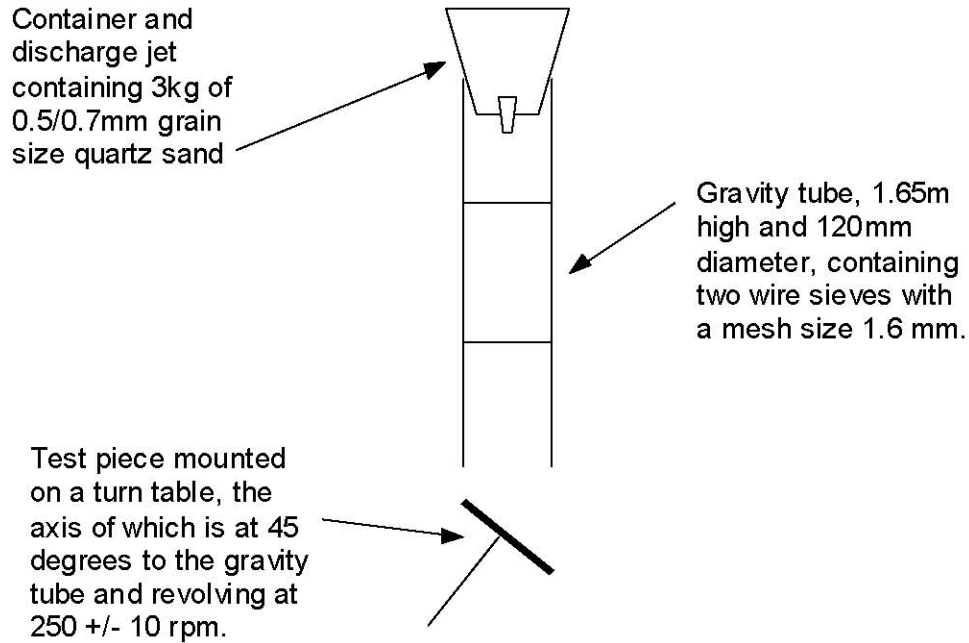

Figure 10. Sand spray apparatus - abrasion test.

3.3.5.4 Tests of refractive powers - visors

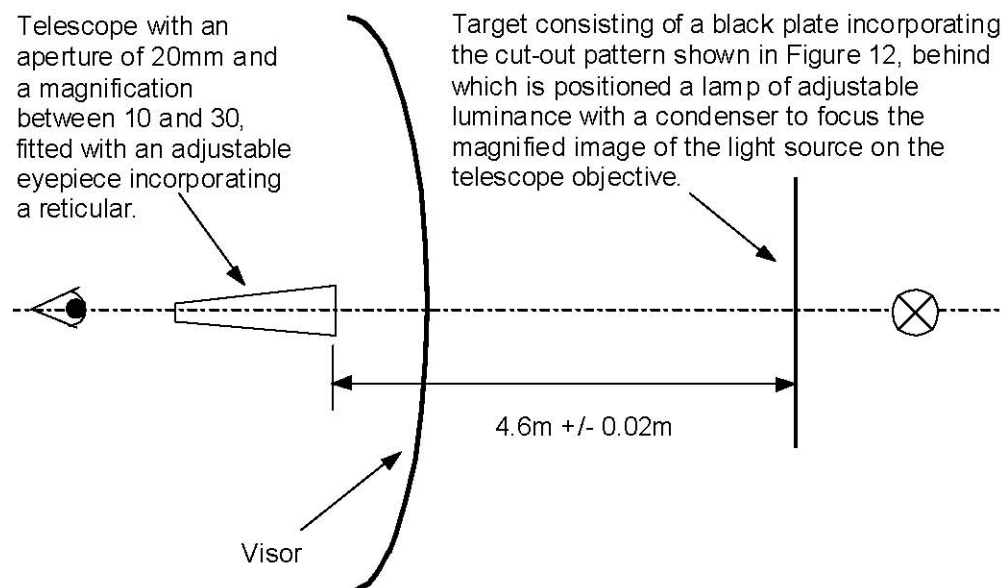
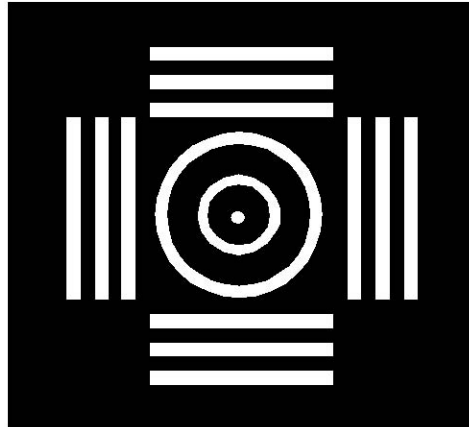

Figure 11. Apparatus for measuring the spherical and astigmatic refractive powers of a visor.



- The large annulus has an outer diameter of 23 ± 0.1 mm with an annular aperture of 0.6 ± 0.1 mm.
- The small annulus has an inner diameter of 11.0 ± 0.1 mm with an annular aperture of 0.6 ± 0.1 mm.
- The central aperture has a diameter of 0.6 ± 0.1 mm.
- The bars are nominally 20 mm long and 2 mm wide with a nominal 2 mm separation.

Figure 12. Telescope target - visor's refractive power test

The spherical and astigmatic refractive powers of a visor are measured by getting an observer to focus the telescope's reticule and the target and to align the telescope to obtain a clear image. This setting is regarded as the zero point of the focusing scale of the telescope. The focusing adjustment of the telescope is then calibrated with calibration lenses having positive and negative spherical refractive powers of 0.06 m^{-1} , 0.12 m^{-1} and 0.25 m^{-1} (tolerance $\pm 0.01 \text{ m}^{-1}$)

The visor is mounted in front of the telescope and :

- for visors without astigmatic refractive power the telescope is adjusted until the image of the target is perfectly resolved. The spherical power of the visor is then read from the scale of the telescope.
- for visors with astigmatic refractive power the target, on the visor, is rotated in order to align the principle meridians of the visor with the bars on the target. The telescope is focused firstly on one set of bars (measurement D1) and then on the perpendicular bars (measurement D2). The spherical power of the visor is the mean of D1 and D2, while the astigmatic refractive power is the absolute difference of the two measurements.

3.3.5.5 Determination of the difference in prismatic refractive power

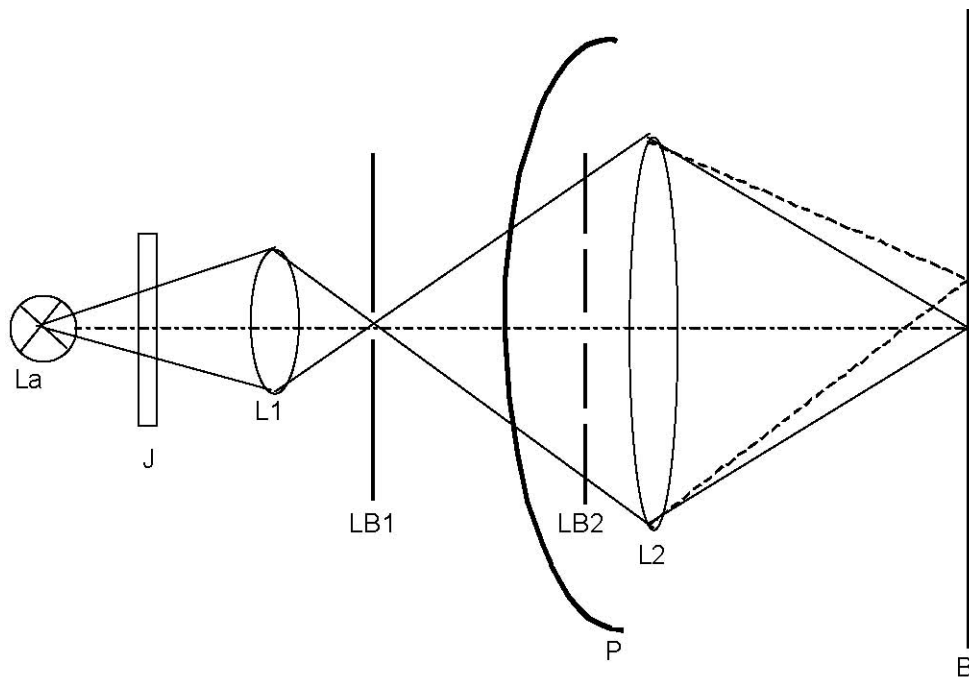

Figure 13. Apparatus for measuring prismatic difference.

Where:

La light source e.g. small filament lamp or laser with wavelength of 600 ± 70 nm.

J interface filter, with peak transmittance in the green part of the spectrum (required only if filament lamp is used).

L1 achromatic lens with focal length between 20 and 50 mm

LB1 diaphragm with diameter of aperture 1mm nominal.

P visor

LB2 diaphragm with apertures 64mm apart (ocular separation)

L2 achromatic lens, 1000mm nominal focal length and 75mm diameter.

B image plane

The diaphragm LB1, illuminated by the light source, is adjusted in such a way that it produces an image on the plane B when the visor (P) is not in position. The visor is placed in front of the lens L2 so that the axis of the visor is parallel to the optical axis of the test assembly. The vertical and horizontal distance between the two displaced images arising from the two ocular areas of the visor are measured. These distance in cm are divided by 2 to give the horizontal and prismatic difference in cm/m.

If the light paths which correspond to the two eye regions cross, the prismatic refractive power is 'base in' and if the light paths do not cross, it is 'base out'.

3.4 Motorcycle goggles

3.4.1 BS EN 1938:1999

3.4.2 Scope

This European Standard specifies requirements and test methods for goggles for motorcycle and moped users (excluding goggles for off-road or competition use).

3.4.3 General specifications - Optical requirements

Oculars for goggles are attributed to three categories (see Table 7). Oculars shall have a luminous transmittance value superior or equal to 18%.

3.4.4 Optical test methods

The optical test methods for goggles are described in EN167:1995 and are similar to the methods for windscreen and visor optical testing, above.

Tests for spherical, astigmatic and prismatic refractive powers, light diffusion, and transmittance are described.

The following table summarises the minimum/maximum optical property values required for approval under UK and European Regulations and Standards.

Table 6. Optical performance values

3.5 Rationale for existing optical quality approval values

Although an extensive literature review was conducted, which identified previous research investigating the effects of degradation on the optical properties of vehicle glazing and motor cycle helmet visors, no firm evidence of any previous research having influenced the current legislative performance conditions was found. Similarly, consultation with personnel involved on the various Standards Committees has so far failed to identify the scientific basis on which current EC or BSI approval is granted. Reference made in a DETR published document to research carried by TRL, which apparently influenced the original lowering of the minimum visor luminous transmittance value from 80% to 50%, transpired to be an informal and unpublished process. However, some further investigation is still to be completed which may yet identify the rationale behind the current specifications.

3.6 Drivers' field of vision - A-pillar obscuration

3.6.1 Council Directive 77/649/EEC

3.6.2 Scope

‘... applies to the 180° forward field of vision of the drivers of vehicles in category M₁ (cars).

3.6.3 General specification

There shall be no obstructions, other than those created by A pillars and/or vent window division bars, rear-view mirrors and windscreen wipers, in the driver's 180° forward direct field of vision below a horizontal plane through V_1 and above three planes through V_2 , one being perpendicular to the plane X-Z and declining forward 4° below the horizontal and the other two being perpendicular to the plane Y-Z and declining 4° below the horizontal. (Figures 14). The angle of binocular obstruction of each A pillar shall not exceed 6° (Figure 15).

No vehicle shall have more than two A pillars.

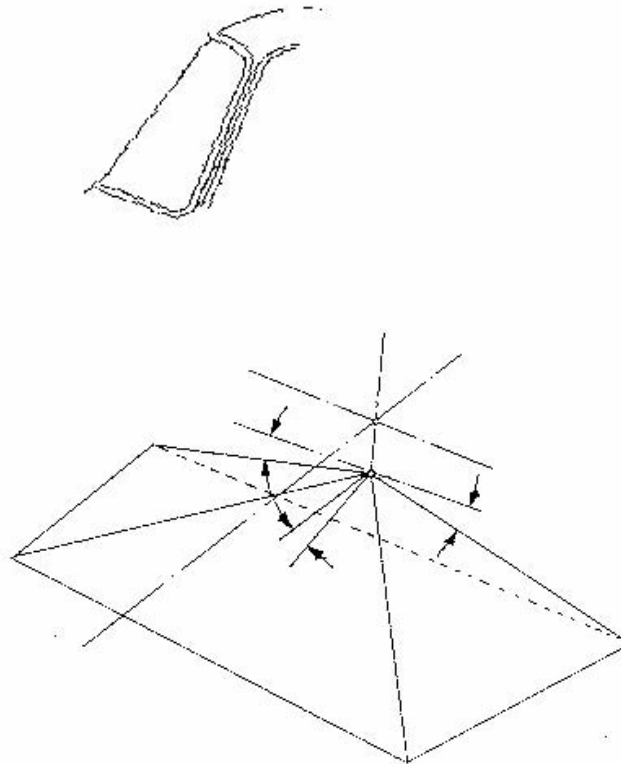

Figure 14. Direct field of vision specification

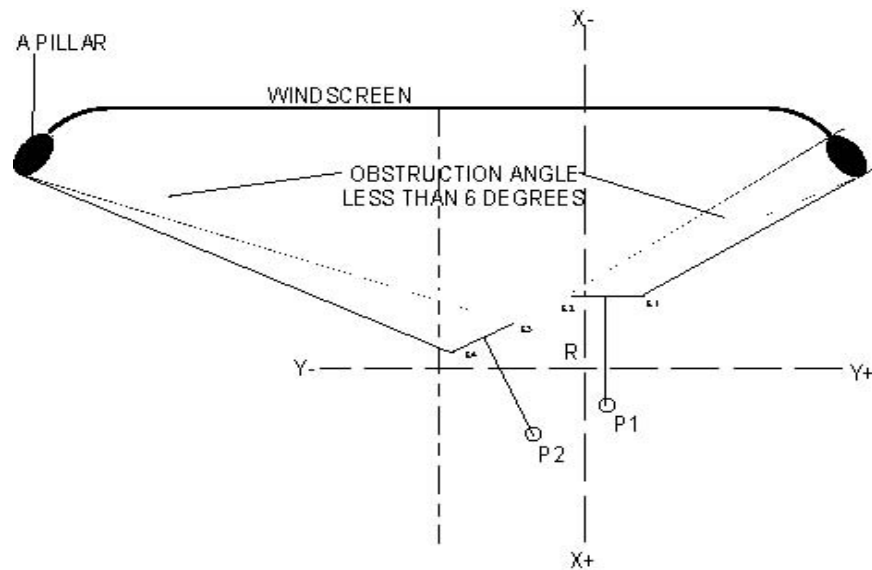

Figure 15. Maximum A pillar obscuration angle

3.6.4 Definitions

A-pillar:- means any roof support forward of the vertical transverse plane located 68mm in front of the V points and includes non-transparent items, such as windscreen mouldings and door frames, attached or contiguous to such a support.

Primary reference marks:- are defined as ‘holes, surfaces, marks and identification signs on the vehicle body which may be the control points used for body-assembly purposes.’

R-point (seating reference point):- defined by the vehicle manufacturer relative to primary reference marks and:

- has co-ordinates determined in relation to the vehicle structure;
- is the theoretical position of the point of torso/thighs rotation (H-point) for the lowest most rearward normal driving position.
- forms the origin of a three-dimensional reference grid

H-point:- is the intersection, in a longitudinal vertical plane, of the theoretical axis of rotation between the thighs and torso of a human body which indicates the position of a seated occupant in the passenger compartment.

Three-dimensional reference grid:- is a reference system which consists of a:

- Vertical longitudinal plane X-Z (+ve X to rear; -ve X to front)
- Horizontal plane X-Y (+ve Y to right; -ve Y to left)
- Vertical transverse plane Y-Z (+ve Z up; -ve Z down)

P-points:- are points about which the driver’s head rotates when he views objects on a horizontal plane at eye level. Two P-points, P_1 and P_2 , are defined which account for some relative movement of the torso as the head is rotated. P_1 and P_2 are positioned relative to the R-point using the three-dimensional grid references.

Table 8. Drivers head rotation point (P) relative to vehicle's 'R' point

E-points:- correspond to the driver's eye position. E_1 and E_2 are 65mm apart and are a 104 mm from P_1 and P_2 .

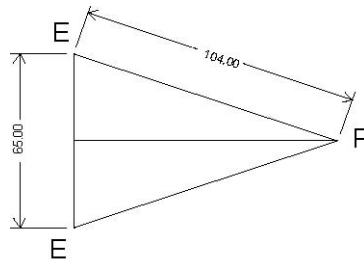

Figure 16. Distance of eye points (E1 & E2) relative to head rotation point (P)

V points are points whose position in the passenger compartment is determined as a function of vertical longitudinal planes passing through the centres of the outermost designated seating positions on the front seat and in relation to the R point.

4. Research

4.1 Rider Vision

Road accident statistics generally tend to show that rate of motorcycles involved in road accidents is higher than cars. For example, an accident study in Germany found that of 10000 licensed vehicles in 1983, the number of fatal accidents involving cars was 25, while for motorbikes, it was 62 (Timmerman, 1985). There could be a number of possible contributing factors to the higher level of motorcycle fatalities. The motorcyclist's failure to see the oncoming hazard could be one such factor. This may be a result of the riders own negligent behaviour (carrying out other tasks which takes their attention away from the road ahead) or due to equipment failure (reduced vision through a visor). Vision through a visor can become reduced through dirt and also when cleaning the visor, abrasions may occur. A visor fitted poorly to the helmet may also lead to abrasions (Waters, 1982). In addition, vision can be reduced by tinting the visor.

4.1.1 The Function of Visors and Goggles

The main function of visors on crash helmets and goggles is to help with rider vision by preventing the wind, dust particles and dirt getting into riders' eyes. However, clear visors do not assist riders' vision when faced with high levels of glare. Glare has been defined as "The dazzling sensation of a relatively bright light which produces unpleasantness or discomfort, or which interferes with optimum vision"(Phillips and Rutstein, 1965). Road users will experience two main types of glare on the road. Firstly, glare could occur at night when driving towards oncoming vehicle headlights. It has been shown by a survey carried by the Road Research Laboratory that 15% of oncoming vehicles dazzled drivers (Phillips and Rutstein, 1965). Secondly, daytime glare experienced on sunny

days, particularly when the sun is low shortly before dusk and when the sun is shining on wet roads, can be a particular problem to riders of motorcycles.

At present, motorcyclists are required to use helmet-mounted visors or goggles which conform with BS4110 (1999: Specifications for Eye Protectors for Vehicle Users) allowing transmittance levels of no less than 50% during the day, to allow for some daylight glare protection, and no less than 80% at night.

4.1.2 Abrasions

A study by Timmerman (1985) looked at how motorcycle helmet visors can contribute to a loss of clarity of vision, particularly after receiving abrasive damage over a high level of usage. Of the 400 visors in use which were tested, the average scattered light component was calculated at 14.4% (i.e. on average, 14.4% of the visors' surface had scattered light), with moped riders as a group having the worst average scattered light level at 21%. It was also found that moped riders and the less experienced motorcycle riders were generally those who used poor visors in terms of the level of damage and from studying accident data, young inexperienced riders were also those who tended to be the ones who were involved in the most accidents involving injuries. It was therefore concluded that damaged or abraded visors increase the risk of accidents to motorcyclists and that to reduce the likelihood of abraded visors being used on the road, better scratch-resistant materials should be used and a greater awareness of the risks of badly abraded visors should be enforced at rider training level.

4.1.3 The use of tinted visors in daylight

Helmet sun visors used by U.S. Navy jet pilots were assessed in terms of their visual acuity in a study by Morris et al.(1991). This report consisted of two studies.

Firstly, the visual acuity of helmeted pilots was tested under four daytime conditions, these being high and low contrast stimuli and low contrast under glare, with and without visors of 12% transmission. The results revealed that the threshold of visual acuity was worst when with low contrast stimuli under glare when using a visor and was significantly worse than the reduction in acuity under glare with no visors. This suggests that visors of 12% transmission may reduce exposure to glare but also considerably reduce the visual acuity threshold.

The second study investigated the effects of five visor's transmittance on contrast acuity, spot detection and sensitivity. The transmittances investigated were 100% (i.e. no visor), 50%, 25%, 12.5% and 6.3%. In terms of spot detection, the spot was required to be significantly larger to be seen with 6.3% transmission than with all other filters, while acuity was found to be worse with the same transmission compared with having no filter at all, but no differences were found with other filter transmissions. In terms of contrast sensitivity, filter density was not a significant factor. It was concluded that filter density can be varied over a wide range before significantly affecting acuity, spot detection or contrast sensitivity (down to 12.5% transmission) and suggest that at least 500cd/m² should reach the eye when wearing visors or sunglasses.

4.1.4 The use of tinted visors at night

Cooper (1983) undertook research to investigate the effects of tints on distance at which objects on unlit roads can be seen at night. Practical tests were carried out by measuring an observer's seeing distance of an object positioned just beyond a glare source (dipped headlights). It was found that seeing distance was reduced by about 6% (3 metres) when a tinted visor of 41% transmission was used instead of a visor with 90% transmission. A theoretical method of measuring seeing distances for different degrees of transmission, with and without glare, was also undertaken. The results supported the findings of the practical tests, as a predicted reduction in seeing distance of 3.4 metres was reported.

Other evidence to support a prohibition of tinting at night was outlined by Wolf et al. (1960, in McLean et al, 1979), who suggested that tinted glass impedes dark adaptation, visual acuity and depth perception.

The undesirability of the use tinted visors at night was also commented upon by Gilkes (in Waters, 1982) who found no evidence that the use tints offer any clear advantage and so to avoid any misuse should not be permitted at all.

In documents provided by DETR titled "Speed Related Severity To Motorcyclists" and "Reduction in Seeing Distance Caused By Tinted Visors And Its Effect On Motorcycle Impact Velocity", it was reported that reduced visor transmittance leads to reduced seeing distances, therefore impact velocities increase, which in turn increases the chance of a more serious injury occurring. As a result, it was recommended that visor tinting should be prohibited.

An article in the journal "Motor Cycle Rider" (1997) states the case for reducing the allowable daytime minimum transmission of tinted visors from the current level of 50% as stated in BS4110. The motorcycle eye protector sub-committee proposed amendments which included better impact resistance, improved abrasion testing and the use of heavier tints to protect from sun glare. It is stated that to provide riders with effective glare protection, a transmission level of 25% would be necessary. As it is stated in this article that contemporary research shows that "scratching is the primary cause of accidents" but "heavily tinted visors fail to play a major part", reducing the minimum transmission tinted visors for use during daylight should not increase accident risks, particularly if interchangeable tinted/clear visor pairs are used which are safer and easier to remove than wearing sunglasses behind a visor.

However, DETR gives reasons for why the current minimum transmission for tinted visors should not be reduced from 50% to 18%. A reduction was said not to be appropriate for visors as they are not easy to change or remove, unlike goggles under sudden deterioration in the light conditions.

4.1.5 Tinting vs Abrasions

As part of an in-depth accident study carried out by the University of Adelaide Road Accident Research Unit (McLean et al, 1979), trends in motorcycle accidents, including evaluating the effectiveness of existing safety measures, were investigated. Accidents involving riders who were wearing visors were examined to determine the extent to which the visors contributed to the accident. Sixteen of the sixty-nine riders involved in the study had clear visors fitted to helmets. The

nine visors which were scratched or dirty were not thought to have affected the riders pre-accident performance. Of the four occasions where clean tinted visors had been worn, it was suggested that one visor may have contributed to the accident, as the rider had failed to see a parked car, but one of many factors could have contributed to the accident.

Another case mentioned in this study involved a rider who was wearing glasses with photosensitive lenses in addition to a scratched tinted visor. It was possible that, although the rider was looking downwards to locate a noise, the visor contributed to the accident because the rider again failed to see a parked car. Both this and the previous accident were similar in that they both occurred under night conditions. At the time of publication, the use of tinted visors (less than 85% transmission) was completely prohibited in Australia (AS1609)(Wigan, 1979) and this study appears to support this for at least night conditions.

An individual case discussed in Waters (1982) involved a rider who was wearing a tinted and abraded visor (34% transmission) at night at the time of driving in to the back of a parked truck (Hope Ide et al. 1981). Visual acuity tests were carried out on the visor to determine the extent to which it would have contributed to the accident. This revealed that the visor did greatly impair vision and that it was the tinting which was more important than abrasion in reducing the vision.

An accident study carried out by Pedder and Hagues (1981), also reported in Waters, found that, of the 117 helmets recovered from fatal accidents, 53 had visors, of which 6 were tinted, and one was accompanied with goggles. Nearly half of all the visors were considered abraded enough to impair the rider's vision and four were known to have contributed to causing the accident. Of the tinted visors, one was thought to have contributed to the accident, but this visor was also badly abraded, so it could not be said which was the greater contributory factor to the accident. Therefore, it was concluded that abrasions could be a factor in 8% of motorcycle accidents, but that tinting had no effect.

Another study by Pedder and Hague (in Waters, 1982) tested visual acuity on various tinted and abraded visors, again at night. The effect of moderate tinting did not move the visual acuity along the visual acuity scale by more than one point and serious reductions in acuity were not found until there was marked scratching of the visor. It was therefore concluded that "the use of moderately tinted visors in excess of 50% have not shown to be a serious hazard and, if daytime use continues to be allowed, consequences of occasional inadvertent or deliberate abuse of them don't appear to be likely to be serious".

4.1.6 Coloured Lenses

Up to now, the reviewed literature has only reported results concerning visors of neutral density or grey. However, a study into yellow coloured lenses for the purpose of night driving was undertaken by Phillips and Rutstein (1965). They reported on research which found that wearing yellow glasses at night improves subjective discomfort, glare and fatigue, but that visual acuity decreased or was at least no better when wearing glasses tinted with colour. The study by Phillips and Rutstein themselves investigated into how tinted spectacles and contact lenses affect recovery times after experiencing glare from an oncoming vehicle. The

results found that although the majority of participants expressed an increase in comfort, their visual performance was worse, i.e. glare recovery times were increased significantly, when wearing tinted spectacles and contact lenses.

4.1.7 Visors - Safe Practice

The Department of Transport (1981) have endeavoured to ensure riders do not use tints at night by outlining in a Proposed Manual on motorcycling the uses of visors and goggles. Their advice to riders is to not use when scratched, pull over and clean visors if dirty, not to use tints at night, not to spray tinting material on and to wear corrective lenses if necessary. The use of clean visors is also outlined in a training leaflet published by the Royal Society for the Prevention of Accidents (RoSPA, 1991) aimed at new motorcyclists and the 1978 version of the Highway Code advises the rider “do not use tinted optical equipment of any kind at night or in conditions of poor visibility” (in Waters, 1982).

Wigan (1979) undertook a review of the standards in use at the time in Australia and other parts of the world for automotive eye protection including visors and goggles. In terms of tinted visors, most standards tend to agree on a minimum transmittance level of around 85% for a clear visor, including AS1609, German standard DIN 58218 and US Voluntary Standard VESC-8 (Vehicle Equipment Safety Commission). In addition, VESC-8 also states that a visor with less than 85% transmittance should be considered tinted and should not be used at night. This paper concludes that more research is needed into the extent to which tinted and abraded visors contribute to the cause of accidents to make specifications more clear cut and until this is done, the quickly replaceable tinted and clear visor pair appears to be the most effective way to overcome conflicts in requirements.

4.1.8 Visors - Subjective Opinions

A number of studies have carried out surveys involving visor users and their opinions on the use of visors. U.S. Navy jet pilots involved in the study carried out by Morris et al.(1991) were asked about visors and sunglasses. It was found that there was much variation in the uses of sunglasses and the types worn. It was suggested by some pilots that a variety of visors with a range of optical densities should be available rather than the single density in use at the time, so they could use the visor which suited them best.

Wigan (1979) reported that users of motorcycle visors prefer clean, unscratched visors to scratched clear visors for use at night and to protect from glare when wearing a clear visor, it was advised by optometrists to wear sunglasses in the visor. However, there were many disadvantages to this (i.e. potentially increased scatter, physical danger in an accident, difficulty to remove when riding) which made this option no better than having a replaceable tinted/clear visor pair. It was also suggested in Wigan that users will use alternatives to clear visors if they are unable to wear tinted visors to protect themselves from glare, including no face protection at all and sunglasses with unknown impact protection.

4.1.9 Other Aspects which may affect visual acuity through visors

As well as tinting and abrasions, there was also a limited amount of discussion in the literature concerning other aspects which may affect the quality and field of vision through motorcycle visors, such as fogging and visor rake angle. A report

by Vaughan et al. looked into developing a test method to assess the fogging of complete eye protectors. This study was carried out after it was found from a survey carried out by the Health and Safety Executive that fogging was the main reason why eye protectors were not being used when needed. A method which could be used to measure the amount of time it took for the clarity of a viewed image (in terms of frequency) to be reduced to 50% and 75% of its original value was devised. This could be of use in the future to test motorcycle visors for reduced clarity in terms of fogging.

It was commented by Wigan (1979) that motorcycle visors are very prone to fogging, and combined with abrasions and dirt, can be more important to the user in terms of reducing vision than tinting. Also mentioned is the fact that helmet visors can often have a rake angle of up 30° , which could also have an effect on visual acuity.

Hayward and Marsh (1988) suggest that as well as better misting (fogging) and abrasion prevention techniques helping to improve the acuity of motorcycle riders view through a visor, this is in turn causing riders' fields of view to be limited. This study also tested how tinted visors with transmission 33.6% affected a riders area of visual field. The results revealed that the area of visual field was no different, with or without the tinted visor. However, this was mainly due to the visual field already being reduced by the helmet thereby making any effect the tint may have had on target detection.

4.1.10 Conclusions to rider vision

To conclude, the literature tended to suggest that there was difficulty, when looking at accident data, in determining the level of contribution tinting and abrasions have on the cause of accidents, as it is rarely the case that a tinted visor involved in an accident will not be abraded as well. It is also often difficult to say whether either were the main cause of an accident.

From looking at the experimental studies, it appears that abraded visors reduced visual acuity more than tinted visors and at a quicker rate. Most studies tend to agree that tinted visors are acceptable at day, sometimes at lower transmissions than the currently accepted 50%, but should be strictly prohibited at night. Interchangeable tinted/clear visor pairs appear to be a more acceptable and efficient way of getting the most out of tinted visors for day and clear visors for night, as opposed to the method of wearing sunglasses under clear visors, which some riders have been reported to do. Very little research on the fogging of visors was found to be available to evaluate the extent to which it could affect the visual acuity of motorcycle riders and understand the extent to which it could be a problem.

4.2 Drivers vision

The project scope, as defined in section 1.0 of this report, included an investigation of those factors which affect driver vision. The literature reviewed has indicated that the factors which affect the quality of vision through the windscreen have undergone investigation in the past twenty years as discussed

below.

4.2.1 Tinting

There are two opposed bodies of thinking regarding the tinting of vehicle glazing. One body, who would like to see transmission levels lowered, believe that there is a net benefit to the road user population in doing this. The other body hold the opinion that the risk to safety is not outweighed by the benefits tinting provides.

4.2.2 Justification for reduced tinting levels

The following benefits to tinting have been cited in the literature.

4.2.2.1 Tinting and accidents

A common concern expressed by the anti-tinting body is that tinting will increase accidents. However studies by Gittelsohn 1973 and Hills 1976 show this not to be the case. In Hills' work a statistical analysis of more than 6000 accidents indicated that vehicles with tinted windscreens:

- Were not over-represented in day and night-time accidents,
- Did not present an increased risk when used by older drivers at night-time compared to during the daytime (Hills 1976).

However other authors have suggested that there were insufficient statistical controls on this data to be confident that accidents are not increased).

4.2.2.2 Tinting and visibility

Roper (as reported in Zwahlen and Schnell 1994) used square targets of 40.64cm side length and uniform reflectance of 0.075 to be detected through a clear windscreen of 88% transmittance and a tinted windscreen of 73% transmittance. The results of the study showed that using a clear windscreen, initial target detection distances of 76-123m were obtained. When the tinted windscreen was used detection distances were reduced by 5%. From this work, Roper concluded that daytime heat absorbing benefits outweigh the loss in visibility at night.

A study by Rompe and Engel 1987 (in Taylor undated) found that for low contrast objects at night, subjects with spectacles have poorer detection rates, times and distances than those with normal eyesight. However for high contrast objects there is no problem. From this it was argued that the benefits of tinting can be gained by applying it to the rear window and since only high contrast objects eg overtaking vehicles are seen at night, transmission levels of 40% are acceptable in rear windows. Even when the rear window transmittances were combined with mirror reflectance losses, which reduced the luminance available to the driver to 12%, test performance was still acceptable.

Prof. Stephen Dain (in Mukherjee 1997) suggests that tint levels to a minimum of 35% are acceptable and Mukherjee refers to BS EN 1936:1997 which permits sunglasses to have luminous transmittances as low as 8% for daytime driving.

However there may be incidents when the detection of low contrast is important eg detecting a pedestrian when reversing at night, and therefore the 40% transmittance proposed above may not be acceptable.

4.2.2.3 Tinting and colour perception

Hills 1976 states that colour vision, visual fields and stereoscopic vision have been shown to be of little or no significance for accident causation.

Mukherjee 1997 suggests that coloration issues can be addressed by using the sun glass standards BS EN 1936:1997.

4.2.2.4 Tinting and glare

Sayer and Traube 1994 found no studies regarding discomfort glare, although Weigt 1986 quotes company car drivers using tinted windscreens who stated that they were not blinded by the headlights of other vehicles at night. However the sample size and the controls used in this survey are not known.

4.2.2.5 Tinting and thermal comfort

Mukherjee 1997 claimed improved thermal comfort during the daytime as a benefit of tinted windscreens which is in agreement with Hurst and Scroger 1974 (in Sayer and Traube 1994).

Work by Hills 1976 showed that in a moving vehicle in the daytime, a tinted windscreen reduced the interior temperature by 0.5-1.5° compared to a vehicle with an untinted screen.

4.2.2.6 Further benefits of tinting

Tinting offers privacy and security and offers increased visual appeal (Mukherjee 1997).

4.2.3 Justification for not reducing tinting levels

4.2.3.1 Tinting and accidents

Little research concerning the affect of tinting on road accidents was found. McFarland et al (in Clark 1993) showed that the night-time accident rate reduces as illumination increases. He argued that since the converse must be true, tinting is likely to increase the night-time accident rate. It was estimated that the ambient lighting from street lighting, signals, etc would need to be increased by 15% to compensate for the effects of tinting. Similar work by Wolf et al (in Proffitt 1996) found that for a given level of dark adaptation, the threshold for detecting light increases when viewing through tinted glass by an amount corresponding to the reduced transmittance value i.e it takes 30% more light to see a target through 70% transmittance glass

In 1991 in Australia, the Primary Vision Area of the windscreen was decreased from 85% to 75% by pressure from the motor trade. Those not in favour of tinting estimated a 2% long-term increment in road night-time accident rate at an additional cost to Australian road users of \$40million per annum. They concluded that the daytime benefits do not compensate for this (Clark 1993).

Clark also stated that research which states no increase in accidents due to tinting is frequently subject to experimental bias, poor statistics, etc, and therefore must be interpreted with caution.

4.2.3.2 Tinting and visibility

Contrast effects: A report for the Virginia General Assembly concluded that ‘...window tinting reduces the ability to detect targets that would be difficult to see through untinted glass, and that this could be a safety liability, especially when ambient light is low’. (Proffitt et al 94). This is supported by Sayer and Traube, who in their 1994 review of visibility research, stated that ‘The existing literature appears to leave little doubt that motor vehicle window transmittance can influence a drivers’ ability to detect objects/obstacles, particularly in dusk or night-time conditions.’ US NHTSA suggests that at twilight a driver is twice as likely not to see a minimal contrast object, such as an unlit bicycle, through 50% transmittance compared to 70% transmittance (the generally agreed standard for windscreens and front side windows).

Rompe and Engel 1987 found that for low contrast objects on the road, accident risk increases greatly for low transmission windscreens. Blackwell (in Hills 1976) similarly concluded that the poorer the visibility of an object, such as a pedestrian in dark clothing, the more detrimental the effects of tinting.

Physiological effects: Several studies have shown that reduction in visibility at low luminance levels is more pronounced for spectacle wearers. Weigt 1986 found that spectacle wearers have more inaccurate detections at low contrast levels with tinted windscreens. Rompe and Engel (in Taylor undated) found that low contrast objects have poorer detection rates, times and distances when viewed by spectacle wearers compared to those with normal eyesight. Rompe and Engel 1987 state that this phenomena is most noticeable for transmission levels below 77%. They conclude that the use of low light transmission windscreens for spectacle wearing drivers is unacceptable.

The effects of age on vision when combined with tinting produce similar difficulties in detection at the threshold level (Allen et al 1996).

Driving effects: A number of studies have been undertaken to determine the affect of windscreen transmittance on various measures relevant to the driving task. Sayer and Traube 1994 in their research review stated that work by Derkum 1993, Heath and Finch 1953, Owens et al 1992, Rompe and Engel 1987 and Waetjen 1992 indicated the negative effects of reduced transmittance on target recognition and detection, visual acuity, reaction time and driving speed.

Target detection: Dunn 1973 (in Proffitt 1996) showed analytically that the probability of target detection decreases with reduced contrast and transmittance values. Contrast sensitivity decreases at a higher rate for transmittance values below 80%. Similarly a study for the Virginia General concluded that ‘..increased levels of window-tinting were associated with an increase in the number of failures to detect a pedestrian in rear-view mirrors and with a decrease in the distance needed to detect this target’ (Proffitt 1996).

Distance perception: A general conclusion by Haber 1955 (in Proffitt 1996) is that distance perception is reduced by tinting. Proffitt 1996 stated that depth perception was reduced by 25-30% when 65-72% filters were used. Research reported by Clark 1993 indicated that objects lit by direct and/or opposing

headlights experience a 5-7% reduction in visibility distance. Pedestrians and cyclists (low contrast objects) experience a reduction in visibility distance of 30%. Olson 1996 quoted the findings of previous studies of the visibility distance for clear and tinted windscreens which showed comparative losses ranging up to 6% for tinted glazing whereas Doane and Rassweiler 1955 (in Proffitt 1996) found that tinting reduces detection distance by 3%. Both Heath and Finch 1953, who compared 89% and 71% transmittance, and Dunn 1973, who compared 96% and 78% transmittance, found a reduction in detection distance of 4.5m for reduced transmittance glazing. However Allen et al 1996 state that although losses in visibility distance may be relatively small, they are usually based on the detection targets being lit which is the condition where tinting has least effect on detection. A further study which suggests that detection distances may be underestimated in the literature is the statement by Hills 1976 that independent researcher have found the reductions in night-time seeing distances to be as great as 30-45%.

Visual acuity: Proffitt 1996 reports that visual acuity is reduced for targets when viewed through tinted glass. For transmission values of 65-72%, targets size needs to be increased by 10-20%.

A generalisation with respect to tinting, noted by Clark 1993, is that work supporting tinting is undertaken or funded by the motor industry whilst work by independent vision professionals does not support tinting.

4.2.3.3 Tinting and colour perception

It can be shown that windscreens can selectively filter red wavelength and that rake, which increases the distance the light has to travel through the glass, intensifies this effect. Measurements of increased rake resulting in increased absorption are shown in the table below.

Table 9. Effect of windscreen rake on light absorption

Measurements with a Pritchard Spectra Photometer showed the following transmissions at 60° rake

The table above shows that the effect of tilting and tinting a windshield results in a greater loss of red light transmittance thus making brake lights and signal lights more difficult to detect (Allen et al 1996). Such an effect will be worse for protanopes (those who are red-colour blind) than those who are normally sighted. (A normal colour sighted person looking through a tinted windscreen will experience a reduction in red sensitivity similar to being a protanope. There is evidence to suggest that a protanopic driver wearing sunglasses looking through a tinted windscreen may not see any red light at all!). To compensate for the loss in colour sensitivity a protanope needs about four times the light intensity required by a normal observer to see a red light (Coles and Brown 1966 in Charman 1997).

Clark 1993 stated that spectrally selective sunglasses and tinted windshields may give a combined transmittance as low as 4%. The combination of windscreen, sunglasses and contact lenses has been investigated, but Dain et al (in Sayer and Traube 1994) were only able to conclude that the reduction in transmission presented a risk to drivers which they could not quantify. Clark 1993 states that adequate relief is a function of: wide-brimmed hats, sun visors and sun glasses

which are readily removable.

4.2.3.4 Tinting and thermal comfort

Hurst and Scroger 1974 (in Hills 1976) stated that windscreen tinting has a minimal effect on thermal comfort. The heat balance is largely affected by infrared against which the pigments used in the tinting have minimal effect.

Clark 1993 states that 'occupant skin surface temperatures can result in discomfort due to a combination of direct solar radiation and high ambient temperature. Tinting can reduce this but effect is small and inadequate; light clothing, sun visors and air conditioning are more effective'.

Allen et al 1996 state that the maximum heat that glazing can reduce is 50% because 50% is supplied by visible light. The heat which is absorbed heats the glass and raises the temperature on both sides and then radiates heat. It is estimated that only 25% of the energy can be kept out of the car. Since the window area is responsible for less than 30% of the energy uptake, only 7.5% is eliminated by tinting. It is suggested that a white-painted and insulated roof would remove up to 44%.

4.2.3.5 Tinting and glare

Glare significantly effects detection and the closer the glare source the shorter the detection distance with dirty or scratched windscreens. Helmers & Lundkvist found that it was the increased levels of stray light resulting from the glare which caused the decrease in detection distances. However the detrimental effects of glare from oncoming vehicles are not reduced by transmission. Sayer and Traube 1994.

Proffitt 1996 states that disability glare is not affected by transmission levels whilst Sayer and Traube 1994 indicate that there is no relevant research data concerning discomfort glare or veiling glare from reflections from the dashboard. For sunglasses 50% luminous transmittance is given as upper limit therefore not achievable by windscreen. Adequate relief is a function of : wide-brimmed hats, sun visors and sun glasses which are readily removable. (Clark 1993).

4.2.3.6 Tinting and privacy

Clark 1993 found that for daytime, the apparent luminance of occupants is 85 to 65% for clear screens, but for 75% transmission windscreens this is reduced to 75% to 40%. While tinting offers increased privacy (although there is no literature which specifically addresses this Sayer and Traube 1994) and increased security for occupants, it is said to degrade road safety, encourage risky driving, reduces the ability for road users to make eye contact and limits the ability of the police to see into the vehicle. The study for the Virginia General Assembly concluded that '... in general, higher levels of window tinting made seeing inside a vehicle more difficult'. This resulted in concerns for patrol officers approaching vehicle in the course of their duties. (Proffitt et al 1996). This is in agreement with the work by Stackhouse and Hancock 1992 (in Sayer and Traube 1994) who examined the ability of approaching personnel to detect various objects, including a firearm, on the vehicle. They found that the subjects were sensitive to changes in the transmission level of the glazing and that this affected their ability to detect

the firearm.

Clark 1993 found no literature to support the claim for increased buyer appeal.

4.2.3.7 Summary study

Many of the aspects discussed above are illustrated in the study described below. Four major manufacturers of after market films petitioned NHSTA for change in regulations to allow film to be applied to the side and rear of passenger car windows reducing transmission to 35%. The film in conjunction with 70% transmission already permitted results in transmission levels of 24.5%. NHSTA invited comment on this proposal from a wide variety of sources. The 78 responses from state agencies/departments dealing with transport safety and law enforcement are given in Table 10 below.

Table 10. Questionnaire responses

4.2.4 General findings

4.2.4.1 Rake angle and transmission

A document by Prof. Stephen Dain, University of New South Wales, (reported in Mukherjee 1997), indicated the following relationship between transmission level and rake angle.

Table 11. Relationship between windscreen light transmission and maximum rake angle

Smith and Bryant 1976 (as reported in Mukherjee 1997) showed that rake angles in excess of 60° from the vertical were common.

4.2.4.2 Recommended levels

Dunn 1973 (in Proffitt 1996) showed analytically that the probability of target detection decreases with reduced contrast and transmittance values. Contrast sensitivity decreases at a higher rate for transmittance **values below 80%**.

Rompe & Engel 1987 (in Proffitt 1996) found increased in visual performance for spectacle wearers at levels **below 70%**.

Weigt 1986 stated that a car glazed with a **windscreen of at least 75%, front-side windows of 70%, rear-side windows of 60% and a back window of 40%** is a good compromise between thermal comfort and driver vision. However the tests were conducted using a rake of 35% not 60% which would reduce visibility performance further.

Rompe and Engel 1987 (in Taylor undated) suggested **40% to the rear**.

Prof. Stephen Dain (in Mukherjee 1997) suggests that tint levels to a **minimum of 35%** are acceptable.

4.2.5 Haze and Abrasion

From the moment a car is first driven on the road, abrasions to the windscreens will occur. Damage to windscreens can be a result of windscreen wiper use, hand cleaning, ice scraping and small particles, such as stones and sand, hitting the windscreen (Allen, 1969, in Helmers and Lundkvist, 1988). The resultant haze and abrasions on windscreens will increase the amount of stray light viewed by a driver. Stray light has been defined as the “light incident on a windscreen which is partially deviated from its original direction by scattering from damaged areas of its surrounding surface” as opposed to useful light which is the “portion of light transmitted without disturbance”. The measurement and effect of abraded windscreens have been discussed in a number of studies.

Allen 1974 (in Sayer and Traube 1994) stated that dirt contributes to reducing drivers visual performance especially under conditions of glare. Glare substantially effects driver visual performance when windscreens are worn (scratched) or dirty due to the stray light produced and the closer the glare source, the shorter the detection distance. (Sayer and Traube 1994). Owens et al 1992 (in Sayer and Traube 1994) note that the light scatter caused by glare is has a greater effect on acuity than age, target contrast or transmittance.

Rompe and Engel (1974) found that for low contrast objects on the road, the risk of accidents increases rapidly with untinted windscreens and haze effects of 1.2%. A further study in 1984 showed that the probability of detecting targets of varying contrast decreased from 91% with a clear windshield to 73% with a windshield having a moderate level of haze (Olson 1996). Work reported by Weigt (1986) showed that a tinted windscreen of 77.4% transmittance and 1.5% haze performed on a par or worse than various tinted windscreens of illegal transmittance. Rompe and Engel (in Weigt 1986) found for viewing objects at the lowest level of contrast through clear windscreens:

- No scatter 75% correct answers
- 1.5% scatter 55% correct answers

The research described above would suggest that haze has a serious detrimental effect on driver vision.

4.2.6 Abrasion

4.2.6.1 Measurement of abrasions

Allen 1969 showed a correlation between the number of miles driven and the number and severity of scratches resulting from wiper operation. At approximately 50,000 miles the windscreen should be replaced or re-polished to restore optimum vision at night against headlight glare (Allen et al 1996).

The problem of dirt and scratches on the windscreen was discussed by Allen et al. (1996). It was suggested that windscreen dirt and scratches can mainly be a problem at night when encountering glare. It is suggested that the windshield should be replaced or repolished to restore the optimum vision in order to protect from headlamp glare at night. A test for scratch deterioration is suggested. This involves observing the sun’s reflection in the windscreen and seeing whether

bright scratch rings show up around the image of the sun, which indicates an older windscreen.

An instrument used to measure scattered light across a windscreen in daylight is described in Timmerman (1986). The results of testing 250 cars using this stray light measuring device found a linear increase in the wear of the windscreens due to impact with small stones with mileage and a more than linear increase of wiper damage. However, it was stated that the level of wear varied among vehicles of identical mileage depending upon the type of use (e.g. motorway, urban, country roads).

Allen (1974) undertook tests to determine the amount of surface dirt and damage on a population sample of vehicles. The results of these tests revealed that dirt and abrasion were common in the sample, with windscreen wiper abrasions being particularly prevalent.

To measure stray light caused by windscreen abrasion, a stray light analyser was used by Haase et al. This enabled two values to be found. Firstly, a mean value of the area of the windscreen which is affected by general haze, and a peak value, which is due to scratches and wiper damage. It was found that both mean and peak values increased with the mileage of the car.

Chmielarz et al (1988) also used a stray light analyser to obtain measurements of windscreen damage in selected regions of Germany and Sweden. Significant regional differences were found, contributions to these differences being made by weather conditions, geographical differences and road conditions, which increase the wear to windshields. Other factors which were found to increase the amount of wear included mileage, parking behaviour (garaged better than on the street) and also age. Younger drivers in Germany had vehicles with higher stray light indexes. Reasons given for this were that younger drivers do not keep large enough distances to preceding cars or that they are less likely to be able to afford more recent cars. Variables such as windscreen cleaning habits, the types of roads used by the driver (e.g. city, country roads, motorways) and smoking habits did not make a difference to the amount of windscreen wear.

Green and Burgess (1981) also measured stray light levels carried out a series of studies to investigate the effect of worn windshields on driver visibility. Stray light levels were measured using a special measuring instrument similar to the stray light analyser used in the previous studies and also using a laboratory method. The results were compared so that the reliability and validity of the measuring instrument could be investigated and found similar results using the instrument and the laboratory method.

4.2.6.2 The effect of abraded windscreens

Allen 1974 (in Sayer and Traube 1994) reported that windshield wear contributed to reducing driver visual performance under conditions of glare. This is due to the stray light produced by the windscreen. Derkum 1991 (in Sayer and Traube 1994) measured 28 vehicles windscreens in various conditions of wear and found moderate-to-high negative correlations between the measurement of scattered light and visual acuity.

Rompe and Engel 1984 and 1987 (in Sayer and Traube 1994) showed that target detection is reduced and speed decreased due to the stray light caused by worn screens. Helmers and Lundkvist 1988 (in Saye and Traube 1994) found that stray light from worn windscreens reduced driver visual performance between 9-25%.

Chauhan and Charman discuss the Mandelbaum effect and the implications it may have on night driving. The Mandelbaum effect occurs when it seems impossible to focus on something in the distance when viewing it through a screen. This could be because given the choice of two targets, a distant one (i.e. the road) and a nearer one which is at the tonic accommodation level (dark focus, resting state) (i.e. the windscreen), the eye will prefer the latter (Owens, 1979, 1984, Adams and Johnson, 1991, in Chauhan and Charman). Testing was carried out to investigate the Mandelbaum effect using both clear and abraded windscreens. However, it was found that rain and scratches produced negligible changes in the accuracy of driver's focusing.

Kessler (1993) discusses how the deterioration of automobile glazing causes stray light by transmission or reflection and how this can affect what the driver can see through the windscreen. Scattered light can often produce "ghost images", i.e., images of glare sources (e.g. headlights) seen by the driver in other parts of their field of view, so instead of seeing one glare source, the driver will see two, the original glare source and the same glare source deflected off the windscreen.

The effects of the windscreen damage on static and dynamic driving tasks were measured and an evaluation into how practical resurfacing the damaged windscreen would be was undertaken (Allen, 1974). The results revealed that dirt and abrasion tended to interfere with the view of the road at night. A recommendation was made to increase public awareness of the problem of windscreen damage and replace or resurface windscreens when considerable damage occurs.

The effect on readaptation times (using a Landolt ring) after being dazzled by a bright light source when looking through a worn screen and a new screen were investigated (Timmerman, 1986). The results revealed longer readaptation times when using a worn screen than a new screen.

Pfeiffer (1970) also found reaction times increased as the level of stray light from a windscreen increased when detecting objects in a static simulation of an opposing situation between two vehicles.

Green and Burgess (1981) undertook a study to investigate the effect of various degrees of windshield damage on participants' response time to safely proceed and rate of errors when viewing a road scene at night. It was found that the rate of errors did not increase as a result of an increase in the severity of windscreen damage, however response times did increase. When adding a glare source to the road scene, error rates were still not affected, but response times increased even more.

Green and Burgess (1981) also reported on an accident study carried out by the

Highway Safety Research Institute in 1978 called the Collision Performance and Injury Report (CPIR). Of 9218 accidents studied, 39 were reported to have a visibility limitation due to the windscreen condition which was considered a potential causal factor of the accident. Two of these were reported to have damaged windscreens prior to the accident which were considered a contributing cause. It was concluded that windscreen damage was not the major cause of any of the accidents.

Olson (1996) reported on a study by Rompe and Engel (1984) which found that the “probability of detecting targets of varying contrasts decreased from 91% with a clear windshield to 73% with a windshield with moderate haze”. The probability decreased even more when a glare source was introduced.

As part of series of tests, Timmerman (1986) carried out a test to investigate worn windscreens at night using Scattered Light Index (SLI) as a measure. Object recognition distances were found to be 7% worse with a windscreen of SLI of 1.7 than with a new windscreen. Peaks with a SLI of 5.0 were found to be mainly caused by wiper damage. Subjective questioning was also undertaken, which found that a SLI of 0.7 or worse was considered to be unsafe for further use.

Tests were also carried out by Haase et al. to investigate the effect of the level of stray light from a windscreen on visibility distances of various objects when encountering an oncoming vehicle. Visibility distance decreased as the stray light index increased and was worsened when the oncoming vehicle low beams were incorrectly positioned. It was concluded that windscreen wear could be a potential contributor to night time accidents as the results show that it causes a reduction in vision at night.

Green and Burgess (1981) carried out a series of four full-scale experiments into the effect of windscreen damage on object detection distances when viewing lights from an opposing vehicle. The first investigated whether detection distances decreased when introducing a new windscreen compared to having no windscreen at all due to stray light. The results found that there was a small decrease in detection distances with a new windscreen (97 -98% of no windscreen condition). The second trial looked at differences in detection distances between a new and a worn windscreen. The worn windscreen was found to reduce visibility considerably, particularly when opposing lights were low beam, as opposed to parking lights, and the target was dark.

The aim of the third experiment was to investigate whether there any differences could be found between windscreens of similar wear in terms of visibility performance. The differences between the two worn windshields (SLI values of 3.04 and 2.50) were very small. The final experiment investigated whether a relationship between the SLI values of windscreens and target detection distances (under headlight illumination) could be found. Detection distances decreased as the SLI values increased, the decrease being more severe as the glare source increased in intensity, and the relationship was found to be approximately linear.

It was concluded that target detection distances were reduced by an increase in windscreen wear, bright opposing glare sources and darker targets.

4.2.7 Reflectance

Sayer and Traube 1994 state that no studies with respect to windscreen reflectance were found. The only additional documentation found by ICE was Allen et al 1996 which provided some general discussion concerning reflection namely that it reduces contrast and increases glare and can be reduced by covering the vehicles dash with a dull black cloth.

4.2.8 Screen bands

Little research was found concerning the performance of screen bands. A report for the US Department of Transportation, NHSTA, entitled 'The effect of light absorbing media on driver visual performance' recommended that shaded bands should not be used unless they do not enter the drivers line of sight. This is because their intended purpose is to reduce glare; they are not designed to work in the same way as sunglasses. Shaded bands do not protect the retinal damage which can be caused by wavelengths of 400-1400 nanometers which pass through vehicle glazing. The reduction in discomfort caused by looking through a shaded band, opposed to a clear or tinted windscreen, may not sufficiently discourage a driver from looking towards the sun e.g. when waiting for a traffic light signal to change, and so may result in retinal damage.

4.2.9 A-Pillar Obstructions

Along with the rear view mirror, the hood and the fenders, the A-pillars have been identified as the main obstructers of the visual field from the driver's seat (Allen, 1996). An object on collision course with the vehicle may be obstructed by the A-pillars, causing the object to be overlooked until it is too late to avoid it. Therefore, the design of the A-pillar is an important factor when trying to maximise the drivers' forward field of view.

4.2.9.1 Design and measurement of A-pillars

Haslegrave (from Peacock and Karwoski in "Automotive Ergonomics") discusses binocular vision and how it can have "very little effect on the view of distant objects... but can have a considerable effect on obscuration caused by objects in the near field of view". This can affect the design of A-pillars, as if the width of the A-pillar is less than the width between the eyes, distant objects will be visible, only a portion of the road directly beyond the pillar will be obscured. EEC Directive 77/649 deals with the binocular obscuration of the A-pillar and takes into account both eye and head turn when assessing the extent of obscuration.

The main techniques used to measure direct field of view are also discussed. The first involves an observer describing the view while sitting in a vehicle, the second uses a camera instead of an observer placed in the position of the driver's eye, which provides a permanent record. The third technique uses lights to represent the driver's eyes, so wherever an object obstructs the field of view, including the A-pillars, the light is obscured. The area of obscuration of the A-pillars or any other objects can be measured using a reference grid marked on a screen which surrounds the vehicle. An alternative to using this sort of laboratory testing is to use computer based modelling systems, such as SAMMIE (Systems for Aiding Man-Machine Interaction).

It is reminded that visual requirements must be incorporated with other design necessities. Most importantly, the positioning and thickness of the A-pillars is essential to the mechanical strength of the vehicle as they form part of the cage which protects the vehicle occupants in the incident of impact or rollover. Therefore, visual requirements should be given consideration at the earliest stage possible in the design process, as this will avoid complex modifications later on.

Fowkes (1986) describes the legislation set out for forward field of view in EEC directives 77/649 and 81/643. This includes a limit set for the binocular obscuration of each A-pillar, which should not exceed 6° from two eye points rotated around a simulated neck pivot.

A-pillars have been described as being potentially able to restrict essential visibility of road signs, oncoming vehicles and pedestrians during driving (Porter and Stearn, 1986). Therefore, a technique to quantify forward field of view was developed. Participants in a trial evaluating the designs of five cars were given a SAMMIE generated visibility grid and were asked to draw on areas which were obscured by objects, such as the A-pillars. Qualitative and quantitative analyses were undertaken by comparing all the completed visibility charts from the same vehicle and then comparing them with the cars in question in order to quantify the angle of A-pillar obscuration. This resulted in the A-pillars of the vehicle in question being moved further around the side of the windscreen and also being reduced in width by removing its thick trim.

Fosberry and Mills (1956) measured windscreen pillar obscuration angles in various cars and found a variation from 2° to 12° . A comparison of these pillar widths were made with the requirements at the time, which revealed that only five out of the fifteen conformed to the recommended requirements and one failed to comply by a negligible amount.

4.2.9.2 The effect of A-pillar design

Bhise carried out an investigation into the “visual field requirements of vehicles in freeway merging situations”, looking at the search and behaviours of drivers. The results included the findings that the A-pillar on the driver’s side caused the greater field of impairment and that 5% of vehicles were found to be in this obscured area at the time of measurement.

Chong and Triggs (1989) investigated the effects of detecting targets when in the vicinity of window post such as an A-pillar. Participants were asked to focus towards a fixation point under one of three conditions, either a mark on a solid post, or at a light through an aperture in an open post or at a light when no post was present. They were then asked to undertake a detection task. A second task was undertaken to measure the effect of various sizes of aperture in the open post on visual accommodation. Detection rates were significantly better with the open post than with the closed post and were worse when the size of the aperture of the open post decreased. It was concluded that visual performance can be influenced in two ways. Firstly, visual accommodation can be influenced such that inappropriate visual accommodation towards the post can occur. Secondly, the presence of a target up to 1-2 degrees from the edge of the post results in them

being detected less easily.

A study by Roscoe and Hull (1982, in Chong and Triggs) found that targets were poorly detected when positioned close to the edges of an intervening post and that the detection of distant targets was affected by post with widths greater than the observers interocular distance.

4.2.10 Conclusions to driver vision

The research concerning the influence of vehicle glazing on driver vision indicates that there is little accident data regarding its effects on road safety.

One aspects of vehicle glazing, tinting, is the subject of much debate regarding the extent to which its benefits outweigh its disadvantages when in use on the road. Tinting, which has been the focus of much research in the 1980s and 1990s, appears to be a particular problem for low contrast objects viewed under low ambient lighting conditions and this is especially the case for spectacle wearers. Experimental work has found that tinting reduces detection rates and increases detection distances and can also reduce the ability of drivers to perceive red lights. Tinting does offers some reduction in interior temperatures but it may not be as effective as other means. Tinting also offers increased privacy although this may be detrimental to the eye contact made between road users and to the police when approaching vehicle occupants. Little research has been conducted with respect to glare but tinting is thought to have little effect if any.

Haze probably has a more detrimental effect on driver vision than tinting and abrasion is also problematic, particularly from windscreen wipers, hand cleaning, stones and dirt. Little data was found regarding reflectance.

As well as causing complete obscuration of part of a driver's forward field of view, A-pillars do appear to interfere with the detection of objects in close vicinity. However, it is clear from the few studies found that further work is required.

4.3 Alternatives and new developments

4.3.1 Alternatives

4.3.1.1 Reverse tilt windscreen

The problems described in the preceding sections concerning glare, thermal discomfort, etc all arise from the rearward slope of the windscreen which has arisen due to the need for aerodynamic performance. If the angle of tilt of the windscreen was to be reversed this would:

- minimise reflections since the glass would reflect the shaded inside portions of the roof,
- shield against the glare from the reflected light caused by the windscreen dirt,
- be less prone to the effects of frost, collect dew or trap air borne dust on outside,
- be easier to clean inside,
- assist in reducing vehicle lift. (Allen et al 1996).

4.3.1.2 Vehicle and people treatments

A combination of vehicle and people treatments could be employed to alleviate some of the problems caused by current windscreen design.

Thermal reductions can be achieved by 'A white roof paint plus roof insulation would eliminate at least 44 per cent of the solar radiation uptake'. (Allen et al 1996). This effect can be improved by appropriate use of light clothing, sun visors, wide brimmed hats, sunglasses and air conditioning. This is more effective than the benefits offered by tinting and more flexible according to the ambient conditions. Clarke 1993.

4.3.2 New developments

4.3.2.1 Light sensitive glazing

'Research Frontiers' proprietary suspended particle device (SPD) technology enables users to electronically and precisely control the passage of light through, windows, sunroofs, sunvisors, mirrors and eyewear, as well as enabling brighter easier to read flat panel displays for computers and other products. SPD film can be controlled automatically by means of a photocell or other sensing or control device, or adjusted manually by the user.' (Research Frontiers Press Release).

The film (activatable material) is laminated between glass or plastic which have transparent, electrically conductive coatings on their inner surfaces which contact the film. When low-current AC voltage is applied to the film the light absorbing particles within the droplets comprising the film align themselves to produce a clear film. If no voltage is applied the particles lie randomly within the droplets and the film is dark blue. (It should be technically possible in the future to produce black or grey). The extent of light transmission is controlled by the amount of voltage applied.

If such a technology could be widely applied in vehicle glazing and rider eye protection the benefits of reduced transmittance by day could be employed without giving rise to disbenefits in conditions of lower ambient illumination.

4.3.3 Water and dirt resistant windscreens

An article by Snooks (1988) looked at the latest window and mirror technology including water and dirt resistant windscreens. These work by applying a special solution which diffuses into the surface of the windscreen and prevents raindrops joining up to form a film. At speeds above 40mph, these drops are blown away from the airflow. As well as raindrops, other benefits to using this solution is that it can help to reduce insect contamination and reduce wiper blade wear.

5. Accident data

5.1 STATS 19

It was proposed that the extent of any road safety issues, caused as a result of poor quality drivers/riders vision, might be assessed through the investigation and analysis of accident data. This methodology has proved unsuccessful or inconclusive for any accident database using the STATS 19 form as its input. Whilst many vehicle, weather and road environment conditions are recorded, no

opportunity is provided for gathering information regarding specific vehicle components unless the attending officer has added additional written notes. These notes are not coded and for this reason are not retrievable through database interrogation.

5.2 TRL fatals database

The Transport Research Laboratory (TRL) maintains a database of road traffic accidents involving fatalities. This is compiled using old police reports which contain full details of the accident. Again, details relating to the condition of vehicle glazing or motor cycle crash helmet visors are not entered on the database. However, the TRL have offered to alert their data entry clerks to our specific needs and will flag reports for our attention if they consider there is a driver visibility issue involved.

5.3 The Glasgow database

This database is held at TRL and records motorcycle accidents where the rider sustained a head injury. Pre 1994 only accidents involving fatal head injuries were recorded but since then non-fatal head injuries have been included - data entry ended in February 1998. No information about the visor used at the time of these accidents was entered on to the database but a small sample of the visors underwent an informal, subjective investigation for evidence of misuse (tinted visors used at inappropriate times) but none was found. TRL have offered to release a sample of these visors for our own investigation should we require them.

5.4 South Yorkshire Police AIB

South Yorkshire Police Accident Investigation Branch have compiled a database of over 200 cars which have been stopped for having side and rear window light transmittance values less than 70%. Roadside testing is now possible with a portable, hand-held device called "Tintman". While none of these vehicles were involved in road traffic accidents, there is evidence that an accident involving a car pulling out in front of a motor cyclist was due, predominantly, to the fitting of tinting film to the side windows. It is believed that the light transmittance value of the side window, through which the car driver failed to notice the oncoming motorcyclist, was about 16%. South Yorkshire Police AIB have offered to assist our research in any way they can.

6. Interviews with drivers and riders

To help ensure that the scope of the testing programme planned for Phase 2 of the project addressed all the key issues a survey was undertaken to seek riders and drivers views on the quality of vision through car windows and motorcyclists' eye protection systems.

Face-to-face interview were conducted with a random selection of drivers in the Loughborough area to seek information on their experiences of the effects of misting, glare, and A-pillar design on visibility. The desirability of tinted windows was also explored as an additional means of probing the issues of sun-glare and dazzle.

In order to obtain first-hand information about the perceived visual performance

of the eye protection options currently available to motorcyclists, a small survey was undertaken of professional and non-professional riders.

Face to face interviews were conducted with 28 motorcyclists drawn from the general public in and around the Loughborough area. The professional rider sample comprised members of Nottinghamshire Police Traffic Section and the Automobile Association's mobile patrol officers. A postal survey was used for the professional riders.

A copy of the questionnaires and the data tables are provided in Appendix 2 and 3.

6.1 Car driver experiences and opinions

Interviews were completed with 30 drivers (14 male, 16 female).

Sample details are given below:-

Table 12. Age and years of driving

Table 13. Age of vehicle

6.1.1 Windscreen misting

Two thirds of the drivers reported that their windscreen sometime or often misted up (21/30). As might be expected this mainly occurred under damp conditions (rain, damp occupants) and when the weather was cold. Cold early mornings being cited on a number of occasions.

Nearly all drivers clear the screen with the car's fan (20/22) and 7/22 said that they sometimes or often had to do this while driving. If this latter point is substantiated then it implies that a not insignificant proportion of drivers regularly drive with reduced visibility through the windscreen.

6.1.2 Windscreen cleaning

The film of dirt which gradually accumulates on the interior surface of the windscreen not only reduces light transmission but also encourages moisture to condense on the screen leading to misting. The dirt film also causes a proportion of light passing through the screen to be scattered resulting in a veiling luminance (haze).

Of 26 replies, 7 drivers had cleaned their screen within the last week, 13 within the last month and 6 less recently than this. The majority (21/29) do not clean the screen regularly but just when they notice it is dirty. Whilst any conclusions which may be drawn from this must be tentative, given for example that we do not know at present the rate at which dirt accumulates on windscreens, we should consider that a significant proportion of windscreens could be suffering haze and misting unnecessarily.

Having stated the above, 23/30 stated that they rarely or never experienced problems with vision due to accumulated dirt on the inside of their car windows.

6.1.3 Sun glare

Problems associated with bright sunlight while driving were experienced often or sometimes by 20/29 drivers, with 4 stating this was often a problem. However only 1 driver reported ever having had an accident or near miss due to this (when reversing out of their drive).

Remedial actions drivers take include using the cars' sun visors (16) and/or wear sunglasses (10).

6.1.4 Tinted windows

None of the respondents had had their windows tinted and of the eight who stated they had tinted windows they were all an OE light tint. Only one driver claimed that the tint influenced their purchase decision when buying the car, stating that as well as reducing glare it gave a degree of privacy.

If cost is ignored, 13/20 drivers said they would have tinted windows. For 9 of them this would include the windscreen, so as to reduce glare.

6.1.5 A-pillar obscuration

The ages of the cars in this small sample means that many of the respondents cars will not have the newer design of A-pillar, which tends to be thicker and more raked. This limits the extent to which conclusions can be drawn from this part of the survey.

11/29 drivers said that the A pillar sometimes or often restricts their vision out of the car and 14 stated that they sometimes or often had to move their head to see round it.

In order to assess whether drivers perceive the trend for increased thicknesses and rakes of A pillar as detrimental to vision, they were asked how the pillar on their current car compared with other cars they had driven. 10 stated it was the same, 8 that it was better and 5 that it was worse.

Two drivers reported near misses that they had experienced as a result of A pillar obscuration. One had had several near misses at T-junctions in several cars and the other had failed to see an approaching car at a roundabout.

6.1.6 Summary - drivers

The drivers in this survey did not experience a significant problem with sun glare, which would motivate them to seek tinted windows.

The most significant observation is the frequency with of screen misting which is cleared while driving (using the fan). This would appear to imply that it is not uncommon for people to drive with impaired visibility through the windscreen.

The drivers interviewed did not clean their screens on a regular basis and this could have implications for the frequency of misting and 'haze'.

6.2 Rider Experiences and Opinions

Completed questionnaires were obtained from 28 members of the public (25 male, 3 female) and 14 professional riders (all male). Sample details are given below:-

Table 14. Age and years of riding

Table 15. Size of motorcycles ridden

Table 16. Use of motorcycle (multiple responses allowed)

Table 17. Frequency of riding

6.2.1 Summary findings

All the riders in the sample used visors and full faced helmets.

Having asked the riders how frequently they rode in different weather conditions they were asked an open question for any comments with a prompt for vision problems.

The main problems raised were:-

- *Rain* (5/14 professional, 1/28 public): water droplets on the visor, which caused light scatter and multiple images of car headlamps.
- *Misting* (5/14 professional, 3/28 public): particularly when riding slowly.
- *Glare* (in bright sunlight) (3/14 professional, 3/28 public).
- *Abrasion* problems were not spontaneously mentioned by any of the riders.

6.2.2 Misting

When asked specifically about this most of the professional riders claimed that their visors suffered from it 'sometimes' or 'often' (13/14). A lower proportion of general riders suffered this problem (12/28) however this may reflect how often riders reported riding in the rain (13/14 professionals 'often' ride in the rain compared to 12/28 general riders).

Misting was reported as being a particular problem at slow speeds, where air circulation through the helmet is insufficient to clear the visor.

6.2.3 Glare

Sun glare was reported as a problem by a high proportion of both professional (11/14) and general (19/28) riders. Whilst the main problem for both groups occurs when the sun is low in the sky, the professionals also reported problems during bright sunlight when the road surface is wet.

Confirming the glare problem, 24/28 public and 11/14 professional riders stated that some form of glare reducing eye protection would be useful in conditions of low sun or bright sunlight.

A smaller proportion of riders has actually resorted to tinted visors. Of the general public 12/28 stated that their visor was tinted (and at least one of these was used

for racing). The range of tinted visors used reflects the current market and includes blue iridescent, gold, black, mirror finish etc). From the responses it would appear the five of the tinted visors would have luminance transmissions below the current required minimum.

Half of the riders in the sample have ridden with tinted visors at night time or in conditions of poor visibility (14/28 general public and 6/14 professional). It is interesting to note that while only 1/14 professional riders is currently using a tinted visor, 8/14 have tried one at some time. The most frequent reason (and reported benefit) being to reduce glare. Seven of these eight riders reported the main disadvantage as being the reduced visibility at lower light levels (dusk, overcast sky and night time). Of all the riders, ten stated that the visor reduced their ability to see under these conditions. A further 2 stated that they adjusted their riding accordingly so it must be assumed that their vision was also reduced.

6.2.4 Changing from tinted to clear visors when visibility declines

Two issues raised by this option were addressed in the survey: how easy is it to change a visor and would riders be prepared to do it?

18/28 general public riders stated that they would be prepared to use tinted visors in bright daylight and change to clear when visibility was poor and at night time. A high proportion (11/14) of professional riders would accept this option, which may result from them having to ride in almost all weather conditions.

It would appear that physically changing the visor is not generally a problem, with 34/38 riders who had ever changed their visor stating that the ease with which they could do it was at least 'acceptable'.

6.2.5 Alternatives to tinted visors

Nearly all the riders had used sunglasses as a means of reducing sun glare while riding (36/42). Three had used helmet peaks and only one had tried a sun-strip. The one benefit of using sunglasses as a means of glare reduction, reported by several riders in the survey, was the ability to put them on or take them off according to conditions.

The most frequent problem cited was the discomfort of wearing sunglasses under some helmets.

6.2.6 Abrasion

The riders did not appear to consider abrasion a significant problem with their visors. 13/14 professional riders and 19/28 of the general riders stated that scratches were 'rarely' or 'never' a problem. Given the average age of their visors (21 months) this must reflect upon the good abrasion qualities of the coatings used on current visors and the effectiveness of the current standard.

However it may be worth considering that as most abrasion will be the result of repeated cleaning and the effects of air borne abrasives, it is likely that riders will adapt to a degree of abrasion and be unaware of some degree of reduced vision.

6.2.7 Summary - riders

The high levels of abrasion resistance of modern materials means that scratched visors are no longer a significant problem for riders.

Misting-up however is a problem, especially when travelling at slow speeds.

Sun-glare, either direct when the sun is low in the sky, or when reflected off wet road surfaces is a significant problem. However riders report that tinted visors do reduce their vision under lower light levels.

Sunglasses are a partial solution to the problem but can often be uncomfortable when worn under a helmet.

7. Plan for Phase 2

Consideration of the work undertaken for Phase 1 confirms that the areas of investigation required by the client are valid and that no other major areas of concern have arisen. In light of this, ICE propose to proceed with the plan of work outlined in their initial proposal to DETR in January 1999. This can now be described in greater detail due to information obtained from the Phase 1 research.

Phase 2 is concerned with identifying the effects on visibility imposed by tinting, haze, abrasion, damage/repair and the size and positioning of structural members and from there defining methods of good practice to account for them.

Prior to the trials, data concerning the representative levels to be replicated in the test work needs to be collected. These levels will be identified through a series of surveys which are described below.

7.1 Surveys

7.1.1 Windscreen rake survey

It is envisaged that a survey of approximately 30 windscreens will be undertaken to identify typical windscreen rakes in common use today. The focus of the survey will therefore be on newer (less than five years old) and the more popular models of vehicles.

7.1.2 Windscreen damage/repair survey

Contact has been made with, and promises of assistance for Phase 2 obtained from, Auto Glass and a professional windscreen replacement service, Save-a-Screen. Samples of damaged screens will be made available to ICE to survey and it is envisaged that repaired screens can also be made available from these sources. Although it is difficult to precisely determine the age of a screen, the age of the vehicle from which it was removed (and possibly its mileage) can be recorded as an approximate guide. It is proposed that prior to inclusion in the trials the windscreens will undergo an initial assessment to determine to what extent windscreen repair is a significant factor affecting driver vision.

7.1.3 Windscreen haze survey

Screen haze which reduces light transmittance and increases light scatter may possibly be measured as part of the windscreen rake survey or the windscreen damage/repair survey described above. A further source of windscreens to measure in this respect would be at a MOT test station where a variety of vehicles

could be assessed at minimal inconvenience to all parties involved. The successful completion of this survey is dependent upon identifying with the client a practical method of measurement which adequately meets DETRs objectives.

7.1.4 Windscreen abrasion survey

The screens measured as part of the haze survey will be cleaned and re-measured. The extent of light scatter measured after cleaning will provide an indication of the degree of abrasion. (The difference in the light scatter measures made before and after cleaning will be attributable to the effects of haze). The successful completion of this survey is dependent upon identifying with the client a practical method of measurement which adequately meets DETRs objectives.

7.1.5 Visor usage survey

Visor misuse in terms of the proportion of visors currently in use which have transmittances below the legal minimum may be obtained by surveying retailers regarding the number and type of visors sold.

A survey of visor misuse will be undertaken. This will not only enable the prevalence of use of illegal visors to be identified, but, by sampling riders at different times of the day and night, the prevalence of inappropriate use for the ambient lighting conditions can also be determined.

Identification of the proportions of both types of misuse from accident data and police sources is not possible for the reasons discussed in section 5.0.

7.1.6 A-pillar survey

Surveys will be made of a range of vehicles to determine A-pillar widths, eye-to-A-pillar geometries and the resultant degree of obscuration imposed. A selection of current and older vehicles will be surveyed to maximise the range of pillar designs to be included in the work. Typical examples may include the Audi A4 and the mini Metro or Volkswagon Polo.

The results of the survey will enable two-dimensional plots to be constructed to enable a graphic comparison of different thicknesses and geometries. BS 6389:1983 / ISO 5721-1981 provide a methodology for this. In addition the survey will also provide the basis of the range of dimensions to be assessed in the experimental work.

Where possible this survey will be conducted in conjunction with the other vehicle surveys described above.

7.2 Quality of vision trials

The visor/screen trials will investigate the effect of tint, haze, abrasion and screen damage on the ability to recognise signals and detect objects on the roadway under conditions of bright sunlight, low sun, overcast, dawn, dusk and night-time (with and without streetlighting). The effects of rain and glare will also be considered.

The extent and consequences of misuse will also be investigated.

7.2.1 Variables - visor/goggle trials

The variables to be considered for the visor/goggles trials include:

Table 18. Visor/Goggle trials variables

7.2.2 Variables - windscreen trials

The variables to be considered for the windscreen trials include:

Table 19. Windscreen trials variables

7.2.3 Methodology

The methodology for the visor/goggle trials and the windscreen trials will be the same and this is described below.

Test equipment

In order to accurately control the levels for the variables and so precisely quantify the results of their interaction, ICE proposes to use its model road facility. Most of the ambient lighting conditions, road conditions, detection objects and signals have already been replicated in other work and so can be readily applied in this context.

Windows, visors and goggles to the levels specified above will be used. These will be held in-situ by one or more purpose built rigs.

Participants

The participants which ICE will use for this work will be a representative sample of the driving public drawn from its database of 400 individuals. It is proposed at this stage that a minimum sample of 20 participants will be used for the work.

Procedure

Based on our previous work it is proposed that a target detection / signal recognition task will be undertaken using the timed exposure shutter. The general procedure will be for the participant to look into the model road through the viewing aperture. The road scene will be exposed by the shutter for 300msec which is approximately equivalent to the brief glimpse drivers may typically give when scanning the road scene as part of their normal driving. The scene will be viewed under each visor, goggle and windscreen viewing conditions under the range of ambient lighting conditions as described above. When the shutter is released and the scene comes into view, a reaction time will be initiated. The participant will be asked to state 'yes' or 'no' according to whether one of the pre-defined target is present in the road scene. (A target is either a signal light or a small object in the road). On hearing the participants response, the experimenter will stop the timer and record the time taken to respond. The participant will then be required to state what they saw as a means of determining both the accuracy of their detection and as a precaution against a perceived safe response of yes always being given. As a further measure against response bias, the targets will not be present on half the occasions that the road scene is exposed for view. This will introduce an element of uncertainty as to what will be encountered in the next viewing scene thereby making the procedure more realistic of the road situation.

Measures

The measures to be used to compare the performance of each visor, goggle and windscreen condition under the various ambient light levels will be:

- the number of times a target was correctly identified,

- the time taken to make the correct identification.

Pilot trials

Preliminary trials to fine-tune the test procedure described above will be undertaken through one or more pilot trials, as required.

7.2.4 Outputs

Visor/goggle trials

On completion of the trials the results regarding the number of correct detections can be used to determine which level of eye protection is most appropriate for each of the ambient conditions tested and which level offers the best compromise across all the conditions. The results will also indicate the extent of the disbenefits which may arise if visors/goggles are misused in unsuitable conditions.

Windscreen trials

With respect to the windscreen trials, the results will determine the maximum tinting levels for use in vehicle glazing. The effect on vision of haze, abrasion, damage/repair and installed light transmission will also be determined and recommendations made concerning acceptable levels for each of these.

7.3 Field of view (A-pillar) trials

The field of view (A-pillar) trials will investigate the effect on driver forward vision of the current trend for improved structural and aerodynamic performance which has resulted in changes in the size and positioning of A-pillars. Concern has been expressed regarding the risk to road safety of these structures in terms of the blind spots they cause and drivers ability to compensate for them.

7.3.1 Variables

The variables to be considered for the A-pillar trials include:

Table 20. A-pillar trials variables

7.3.2 Methodology

Test equipment

A purpose built rig will be constructed to replicate a variety of A-pillar thicknesses and geometries. The rig will be surrounded by a circular screen onto which a road scene will be placed. Incorporated at a representative viewing angle within the screen will be a p.c. monitor which will scroll through pages of road signs which the participant will need to 'follow'.

On top of the rig will be a projector on a turn-table. This will permit the projector to display an image at any given location on the screen in participants forward field of view. Two types of image will be used, one to be representative of a child and one to be representative of something smaller such as a ball or a cat. The luminance contrast of the projected image onto the screen will be carefully controlled to ensure that the object will be visible when it is in un-obstructed view. (This is not a visibility test in terms of contrast-detection and it is for this reason that a suitable background to aid detection will be used).

Participants

The participants which ICE will use for this work will be a representative sample

of the driving public drawn from its database of 400 individuals. It is proposed at this stage that a minimum sample of 20 participants will be used for the work.

Procedure

Each participant will sit within the test rig which will be set to one of the pillar designs to be tested. To make the task of object detection more representative of the driving situation, a primary task requiring a high degree of attention will be undertaken. This will take the form of searching road signs, which are displayed at intervals on a p.c. monitor, for a given town. The specific town which the participant is looking for may not always be present but the participant will need to search the road sign to determine this since, if the town is present, the directional arrow beside it will need to be 'followed' i.e. the participant will need to undertake some action to represent a turn to the right or left. (This task has been successfully used in previous DETR trials). The participant will be prompted at intervals by the experimenter that an object may appear in the road scene i.e. on the screen surrounding the rig. If they see it they will need to respond by stating 'yes' and giving the location of the object. To add an element of uncertainty, the object will only appear on half the number of occasions that the participant is prompted. In addition the intervals between the point where the participant is prompted by the experimenter and the point where the object appears will be variable thereby adding further uncertainty. On those occasions where an object is projected, the initiation of the display of the object will start a reaction timer which will be stopped on the participant saying 'yes'. The participant's response and the time taken to make it will be recorded by the experimenter. When all objects have been presented in all locations (in a randomised order), the participant will be given an opportunity to rest whilst the rig is modified to the next A-pillar design to be assessed.

Measures

The same measures will be used as were used for the quality of view trials namely:

- the number of times a target was correctly identified,
- the time taken to make the correct identification.

Comparison of participants scores on each of these measures will enable a comparison of the visual loss, and therefore risk to safety, caused by different A-pillar designs.

Pilot trials

Preliminary trials to fine-tune the test procedure described above will be undertaken through one or more pilot trials, as required.

7.3.3 Outputs

The results of these trials will provide a scientific basis for determining if recent trends in A-pillar size and positioning are likely to contribute a risk to road safety. The test results will be supported by 2-dimensional graphical representations to enable easy visual comparisons to be made.

7.4 Proposals and costings

The optimum levels for the various factors which affect visibility will be identified from the test programme and their implementation costs investigated. The relevant contacts made in Phase 1 will be approached to obtain realistic industry costings.

In light of the lack of availability of accident data to date, a full cost-benefit analysis may not be possible. However, if this is the case, all relevant information found in the course of the project will be presented for consideration with the client and alternative methods for appraisal will be discussed.

Estimates of potential misuse will be obtained from the visor survey (see section 7.2.5) and, in conjunction with the results of the testwork, will provide an indication of the scale of the problem associated with the misuse of visors.

7.5 Amendments to legislation and enforcement practices

For those visibility enhancements which are not judged to be cost prohibitive, amendments to the relevant standards, regulations and Directives, as identified in section 3.0, will be proposed.

The proposals will follow the format of legislative amendments made in previous DETR projects. Similarly the recommendations made can be used as the basis for Codes of Practice for those aspects not covered by existing legislature.

7.6 Final report

The final report will cover all aspects of the work undertaken in the course of this project. As well as a clear statement of the project objectives and recommendations, full reference will be made to the initial research, experimental testing and results analysis thereby documenting the scientific integrity of the work.

The final project report will include:

- executive summary,
- abstract,
- introduction,
- method,
- results,
- discussion,
- conclusions,
- recommendations.

Hard copies

Two draft copies and five hard copies of the final report will be made available to the client.

Electronic copies

The report will also be made available in electronic form on 3.5" disk in Microsoft Word 6.0 format.

7.7 Work plan

7.7.1 Scheduling

A work plan showing how the activities described for Phase 2 will be achieved is presented below.

7.7.2 Items for consultation

The rider and driver interviews indicated that misting is considered to be an important factor contributing towards the quality of vision. It is therefore proposed to discuss in greater detail with the client the most effective means for considering misting as well as reflection, haze and abrasion within the scope of the phase 2 testing.

Table 21. Phase Two tasks and scheduling

8. References

9. Appendices

9.1 Appendix 1. Contacts

9.2 Appendix 2. Driver vision survey data

Interview sample

Total sample size = 30 , (14 male, 16 female)

Age and years of driving

Age of vehicle

Have you ever had a new windscreen fitted?

Does mist on the inside of your windscreen ever reduce your vision outside the car?

If Yes: under what circumstances?

How do you clear it?

Do you ever have to clear it while driving?

When did you last clean the inside of your windscreen of accumulated dirt?

Comments

Do you clean the inside of your windows routinely or just when you notice they are dirty.

Have you ever experienced problems with vision because of accumulated dirt on the inside of your windows (e.g. due to dazzle from headlights at night)?

Comments e.g. vision problems experienced

Do you ever experience problems driving in bright sunlight?

Comments e.g. vision problems experienced

If yes what do you do about it?

Have you had any accidents or near misses because of glare or dazzle from bright sunlight?

Description

- Winter low sun (previous car), especially if windscreen frosty - can't see parked cars as back out of drive

Are any of the windows in your car tinted?

If yes, Were they tinted when you acquired the car?

Did it influence your purchase decision?

-

Like tinted windows as give privacy and reduce glare

Ignoring the cost, would you consider having tinted windows in your car?

Which?

Why?

Thinking now about the pillars at the side of the windscreen in your car (A pillars). Would you say that they ever restrict your vision out of the car?

Are you aware of ever having to move your head to be able to see around the pillar?

How does this pillar compare to other cars you have driven in terms of its effects on visibility?

Comments

Have you had any accidents or near misses because of things being obscured by this pillar?

Description

- Approaching T junction 3 or 4 near misses over the years (various cars)
- Near miss, roundabouts, didn't see car

9.3 Appendix 3. Motorcyclists eye protection survey data

Interview sample

Public = 28, 25 male, 3 female

Professional (Police and AA) = 14, 14 male, 0 female.

Age and years of riding

Size of motorcycles ridden

Use of motorcycle (multiple responses allowed)

Frequency of riding

Motorcycle club membership

Motorcycle magazines and newspapers read

Type of helmet and eye protection worn

Age of current eye protection

How often would you say you ride under the following conditions?

Comments e.g. vision problems

Comments e.g. vision problems

Do you even have problems seeing through your visor or goggles due to misting up/fogging?

Comments e.g. circumstances, vision problems

Professionals

General public

Have you/do you ever experience problems due to scratches on your visor/goggles?

Comments e.g. circumstances, vision problems

Professionals

- With heavy use during police patrol work the visor last at least two years. However the visor is usually cleaned before the start of each shift and the helmet placed in a protective bag between shifts
- Latest "ZA" visors rarely scratch and if they do, do not unduly obscure vision or cause "starring" as old technology visors
- mainly sunlight glare
- never had problems because visor changed on regular basis
- I change the visor when scratched
- I change it as soon as it is scratched
- Always change visor if it gets scratched and always clean daily
- Stone chips and cleaning scratches
- replaced if affected

General public

- gradual build up of scratches until a new visor is required.
- in bright sun light
- don't let it get scratched
- throw away if get any on
- people knock it and scratch it
- replace them if get scratched
- cheap visor will scratch
- change if gets scratched
- what wears them out
 - throw away if gets scratched
- look after it
- sunshine causes problems

Do you ever experience problems of glare from bright sunlight while riding?

Comments e.g. circumstances, vision problems

Professionals

- Low sun & reflected glare
- Low sun conditions or wet road surfaces in bright sunny conditions
- Unable to see without squinting causing eye strain
- particular problem when riding into sun, especially when low in sky or over wet roads

- wear sunglasses
- Riding over brown hills into sunlight vision problem blindness for a few seconds. Early morning sun rises, you don't know when its going to get you in the eyes. Bright sunlight reflecting off wet roads (evil)
- The visor is clear, you need a tinted visor
- I have to use sunglasses to stop this
- use sunglasses

General public

- Low sun
- when sun is low
- Tinted visor
- with dark visors
- Low sunlight
- Sunglasses help a peak would be useful sometimes but is a problem at higher speeds
- as above
- glare
- every day
- Glare a real problem, even with smoked visor
- and headlights are major problem
- wear tinted visor when need to
- will reflect sun, very difficult to see
- sun of wet roads
- dazzle
- dark in sun and clear when not
- but I generally wear sunglasses anyway, whether on bike or in car
- If can't glasses, reflective glare off wet roads in bright sunlight is evil

Do you find times when visors/goggles which reduce glare would be useful?

Comments – why and when?

Professional

- When the sun is low
- Sunrise and sunset especially during winter low sun positions
- Bright sunlight generally - low sun e.g. late evening
- Always wear sunglasses
- Dark visors are particularly good at reducing glare in bright sunlight conditions. Even when slightly overcast - relieve eye strain /Headaches during daylight only though
- Obviously in bright sunlight and glare caused by sun, lights, glare from wet roads. Reduces eyestrain.
- Riding in wet sunny conditions also snow conditions
- Bright sun brings on hay fever and sneezing
- It would be nice if you could have a reactor type visor like you can by glasses lens
- low winter sun

General public

- Most of time
- Bright sunlight

- Bright sunlight
- As for bright sunlight - sunglasses too limited & complicated
- for sunlight
- in the evening , against sunlight
- bright sunlight, car headlights & built up areas
- Bright sunlight , headlights at night
- use sunglasses
- bright sunlight
- every day
- sun, all the time
- full headlights main problem
- bright sunlight
- smoked/tinted are very good to reduce glare . All the time good, but night no good
- sunlight
- Sunlight
- bright lights of cars affect vision
- problems if use in dark - change colour visor would be a possibility
- wear tinted when sunny
- bright sunlight
- at times when sun straight in eyes. Wearing sunglasses is difficult
- when wet but bright

Is/are your visor/goggles tinted?

- Blue Iridescent
- dark
- gold
- Gold#1 ¼ tint
- medium
- race v dark
- V dark
- Blue mirror finish
- illegal black
- legally smoked
- black for racing

Have you ever used tinted visors or goggles?

Amount and colour

- dark (medium)
- blue mirror finish
- all black
- light smoked glare
- Black or graduated
- Graded
- Blue externally/black inside
- Slight tint black
- light tint black
- Black tint

- light tint black

Why?

- comfort & style
- during bright day
- looks better than clear
- reduce glare
- on my old helmet
- long time ago
- To reduce glare
- During motorcycle racing events
- Avoid glare
- reduce glare effectively - more comfortable than wearing sunglasses
- Just to try but preferred sunglasses
- To stop sun glare
- Cut glare
- to reduce glare

What were the benefits of the tinted visor/goggles?

- Reduced glare & reduced eye squint
- Reducing glare and dazzle to an acceptable level without the need to wear sunglasses under the helmet. Being a person who wears spectacles the only other option is to wear clip-on sunglasses which are heavy or prescription sunglasses which are expensive
- Aid Vision
- Particularly good at reducing glare - eye strain/headaches. Much more comfortable than wearing specs under helmet which dig into bridge of nose above ears - might cause injury in RTA
- Gave good all round tinted vision and not as cumbersome as sunglasses
- Stop glare from bright sunlight (safer to ride)
- Cuts glare helps to stop sneezing due to hay-fever helps prevent migraine through bright light
- did not trust the tinted visor for U/V eye protection
- Loss eye strain
- sun & looks good
- Looks good, can see in bright light
- Comfort with vision
- convenience & vision in sunlight
- reduced glare
- better vision & cosmetic
- reduced glare
- reduce glare
- reduce glare
- reduced glare
- reduce glare
- very good in sun as I ride most in sun. rubbish at night. Look good
- Reduces glare without need for glasses
- See where going, don't have sun visor & not able put sunglasses on like drivers can
- no benefits

Were there any disadvantages to using tinted visor/goggles?

- Night time visibility impaired
- Tints do not allow for changes in light levels or failing light conditions ie. on a bright sunny day entering an area with overhanging trees, entering a tunnel etc. could cause problems
- Had to carry spare clear visor if trading at night in same journey
- Unsuitable for riding on unlit roads at night
- Can't remove visor if it goes dark, because of reduce light
- Poor visibility at night (not safe)
- Night time use been out in the rain
- dark days
- not really
- can't see at night
- When it gets dark cant see
- limited visibility at dusk
- caught out at night/overcast
- You cant see at night
- Night time if get caught without clear visor then have to come back without one on
- not always smoked enough - still have problems with glare even with tinted visor
- if gets dark or cloudy get reduced vision
- night times could not use
- shouldn't wear at night
- night riding problems

Have you ever ridden with tinted visor/goggles at night or during poor visibility?

Comments

- Tinted visors at night severley affected contrast. Kerbs and road edges merge and are difficult to pick out
- With a graduated tint visor which had a yellowish tint. The yellow tint enhanced vision in low light conditions as per night driving glasses
- Left home in bright sunlight and got caught in heavy rain/spray - no real affect on vision. Returned home after dark with dark visor - which partially reduced vision on unlit road - No problems on roads with street lighting
- Used yellow glasses/goggles at night to reduce glare - better visibility
- I change visor
- you can not see a thing in the dark
- reduce vision
- just riding. No problems
- On way home at night or if gets overcast. No real probs - go slower
- visibility vastly reduced
- adjust riding to suit visibility
- Couldn't see at all
- as previous
- no problems
- never worn tinted visor
- not very good
- lots of times fog, snow, night and rain

- wouldn't want to
- couldn't see well - not choose to do it
- couldn't see well
- Is hard, swap for clear
- Long time ago
- Are you legally allowed to ride at night with tinted visor

Would you be prepared to use tinted visor/goggles in bright daylight and change to clear at times of poor visibility and night-time?

Thinking about removing and re-fitting your visor to your helmet, would you rate this task as...

Have you used any other type of eye protection for glare when riding e.g. a helmet peak, sunglasses or sun strip

What?

- Sunglasses (32 people responded)
- Sunglasses & Helmet peak
- Sunglasses - on road Peak - off road
- Sunglasses under tinted visor
- all above. peak rubbish sunglasses rubbish, sun strip ok but might as well have tint

Comments

- I don't like riding with sun glasses under a helmet
- Used to prevent glare during sunny conditions
- Very good and can be removed easily if visibility decreases
- As already stated, they are uncomfortable to wear (bridge of nose/above ears) Could cause injury in impact
- Helmet peak used on off road motorcycle. use sunglasses during daylight on regular basis
- Glasses are best option for me, but after a long time riding they become uncomfortable.
- regular use in bright sun conditions
- To stop sun glare
- Ease of removal & can be worn at your journeys end i.e. race meetings etc.
- It improves your vision and alert
- very good
- cutting of glare

What were the benefits of using these?

- Reduced glare in bright sunshine
- easier to change than a visor
- avoid glare
- Reduction of glare
- Reduce glare for sun/lights but this is counteracted by lack of comfort
- lass eyestrain.

- Reduce glare etc.
- Easier to store i.e. in your pocket can be removed easily when it goes dark
- reduces glare
- They mist up
- they are uncomfortable under a crash helmet digging in your ears and nose
- Only having to remove as the light falls also under ground car parks which we do a lot of work in
- Reduces light - comfort
- Eye protection with visor up
- wears spectacles as well so can replace specs with corrective sunglasses
- convenient if caught out by poor visibility
- good visibility
- so easy to take off
- reduce glare
- Multi purpose i.e. useful off the bike. Mine are prescription sunglasses
- reduce glare
- reduce glare
- reduces glare enough to be able to see - legal tint isn't enough to reduce enough
- reduce glare
- peak looks rubbish and not effective. Glasses not comfy
- reduce glare
- reduce glare
- reduces glare
- reduce glare
- Easy to remove when necessary
- Offer some protection to eyes without steaming up and allows air to filter when hot.
- e.g. slow moving
- reduce glare

Were there any disadvantages to using these?

- Problems when entering shadows etc.
- can be uncomfortable under the helmet padding
- slightly uncomfortable
- Glasses do not fit particularly well in helmets
- Discomfort
- Only if cleaned properly
- No provided not too dark tint
- Tinted visors be made legal for daytime riding
- Change visor when scratched use a fogcity shield inside visor for misting
- I have tried many different types of motorcycle helmet makes and up to now none of them have a very good anti misting system. I am currently using the shoei A-V this has a good visor easy to remove and the best anti fogging
- I think that we could look at some form of demisting system that works all the time and is cheap
- Not really
- cant take off when riding
- same as wearing glasses
- not really
- cant take off when riding
- tight fit in helmet

- Need to keep safe when not in use. One is thrown into darkness going through a tunnel or dark wooded area
- move around on face, not designed to fit within helmet
- not if wear proper sports sunglasses - wrap around (otherwise get blind spots)
- remember take sunglasses off first before helmet
- makes head hurt due to pressure of helmet after time
- Wrong that not legal - should be legalised. Need more information so everyone knows what is what
- Problems in tunnels or darker areas - see less also glasses mist up more often than visor
- look horrible
- Have to carry around
- risk of damage to eyes as not high impact awkward to take off if sunglasses in tunnel etc when riding.

Do you have any other comments about tinted visors/goggles, scratches or misting/fogging?

- I have now swapped to using contact lenses because of problems with spectacles steaming up. The only thing which seems to prevent fogging is application of washing up liquid to the inside face of the visor but it needs to be done prior to every days use
- a lot of sports bike rider, I suppose, wear them for other reasons other than anti-glare. i.e. image, pose
- Personally, I find misting /Fogging more of a problem than glare
- I believe that tinted visors up to 75% tint should be legal for use during daylight, as they are a great benefit. Most helmet manufacturers have visor fitting/removing systems which are easy to operate some can be changed whilst still wearing this helmet
- Scratched or poorly maintained visors/goggles are the main cause of visibility reduction. I do not feel that dark/tinted visors, if used safely are any risk and would be preferable to wearing sunglasses
- there are plenty of anti fog products on the market now, some are easy to use, some work well i.e. fog shield, Bob Heath anti fog spray. tinted visors are now seen by many young riders as a fashion statement rather than being practical .
- Let rider decide what's best for them
- Tear-off good option 3 @£5.00 take off in dark & use up to 12 times you can use more for extra tint
- Scratches need throw away as soon as happens. Tinted visors if used properly are good. Crazy that legal to ride with clear visors and sunglasses at night, yet not legal to use dark visor in sun
- Can remove at night time . Should be legalised darker visors
- Nice to make steam-up visor and scratch resistant visor - be prepared to pay more as would be value for money
- scratches are big problem have to replace visor as can be distracting. have to be prepared to change tinted visor if using one
- much nicer not to have tinted visors
- should legalise dark visor
- tinted visors can be seen as intimidating to other people
- Tinted visor might reduce contrast if sun goes in, effects all vision, but would be good in sunny weather

- I don't think eye protection has moved on very much since the days of motorcycling unlined clothing and helmet protection.
- Prescription glasses are fiddle to take on and off and are susceptible to damage by taking helmet off before removing glasses etc.

Over	Not over	1987	1997
	50cc	352	96
50cc	125cc	347	143
125cc	150cc	4	1
150cc	200cc	39	12
200cc	250cc	78	44
250cc	350cc	13	10
350cc	500cc	46	54
500cc		99	265
All over 50cc		626	530
All engine sizes		978	626
		thousands	

Reading	With test piece	With light trap	With reflectance standard	Quality represented
T1	No	No	Yes	Incident light
T2	Yes	No	Yes	Total light transmitted by test piece
T3	No	Yes	No	Light scattered by instrument
T4	Yes	Yes	No	Light scattered by instrument and test piece.

e11 AA Foundation for Road Safety Research

Zone	Area	Permitted repair
A	Centred on a longitudinal vertical plane passing through the centre of the driver's seat and bounded by the arc described by the driver's wiper	damage within a circle 10mm in diameter
B	area wiped on driver's side, excluding zone A	damage within a circle 15mm in diameter
C	area wiped on passenger's side, excluding zone B	damage within a circle 25mm in diameter

D	areas excluding zones A, B and C.	damage within a circle 40mm in diameter
Note 1 - For HGV and coach windscreens, damage up to 150mm in length may be repaired		
Note 2 - Repairs less than 100mm apart should not be carried out.		

Before abrasion	After abrasion
0.65 cd/m ² /l (method 'a' and 'c')	5.0 cd/m ² /l (method 'a' and 'c')
2.5 % (method 'b')	20 % (method 'b')

Visor position	Diaphragm type	Detector reading	Measurement
P1	Circular	flux T _{1c}	Undiffused light transmitted by the visor.
P1	Annular	flux T _{1a}	Total diffused light originating from the visor and from the apparatus
P2	Annular	flux T _{2a}	Diffused light coming from the apparatus only
No visor sample	Circular	flux T _{0c}	The total light

Optical property	Windscreens (ECE Reg. No. 43)	Laminated windscreen repair (BS AU 251:1994)	Visors (ECE Reg. No. 22 - incorporating 05 series of amendments)	Goggles (BS EN 1938:1999)	Sunglasses (BS EN1836:1997)
Luminous Transmittance. Light transmission	>75% windscreens >70% windows other than windscreens (9.1.4.1)		Visors shall have a luminous transmittance $\tau_v \geq 80\%$, relative to the standard illuminant D65. A luminous transmittance $80\% > \tau_v \geq 50\%$ is also permissible if	18% to 80% depending on filter category (see table 7 below)	3% to 80% depending on filter category (see table 7 below)

			the visor is marked 'For Daytime Use Only'. (6.15.3.4).		
Spectral Transmittance			For wavelengths between 500nm and 650nm the spectral transmittance of the visor shall not be less than $0.2\tau_v$. (6.15.3.7)	As BS EN1836:1997	For wavelengths between 500nm and 650nm the spectral transmittance of filters suitable for road use and driving (categories 0, 1, 2, or 3) shall be not less than $0.2\tau_v$ (4.1.2.2)
Recognition of signal lights. Relative attenuation quotient (Q)			<ul style="list-style-type: none"> • 0.8 for red and yellow signal lights • 0.6 for green signal light • 0.4 for blue signal light <p>Note: BS 4110:1999 (Visors for vehicle users) specifies $Q \geq 0.8$ for red, yellow, green and blue signal light recognition.</p>	As BS EN1836:1997	The relative visual attenuation quotient Q of filters of categories 0, 1, 2, and 3 shall be:- <ul style="list-style-type: none"> • >0.8 for red and yellow signal lights, • > 0.4 for the blue signal light and • >0.6 for the green signal light. (4.1.2.2.2)
Identification of colours	When a windscreen is tinted the following colours shall be identifiable:-				The relative visual attenuation quotient of filters of scale numbers 5-1.1

	(9.4) white selective yellow red green blue amber				to 5-3.1 and 6- 1.1 to 6-3.1 (suitable for driving) for signal lights red, yellow, green and blue shall not be less than 0.8 (<i>BS EN 172:1994 - 4.2.3</i>).
Optical distortion	A windscreen type will be considered satisfactory if optical distortion does not exceed:- (9.2.6) • 2' of arc (M1 category vehicle, windscreen zone A) • 6' of arc (M1 category vehicle, windscreen zone B) • 2' of arc (M and N category vehicles, windscreen zone I)	Optical distortion of the repaired area shall not exceed 2' of arc. (8.6)			
Secondary image separation	A windscreen type shall be considered satisfactory if secondary image separation does not exceed:- (9.3.5) • 15' of				

	<p>arc (M1 category vehicle, windscreen zone A)</p> <ul style="list-style-type: none"> • 25' of <p>arc (M1 category vehicle, windscreen zone B)</p> <ul style="list-style-type: none"> • 15' of <p>arc (M and N category vehicles, windscreen zone I)</p>				
<p>Resistance to abrasion Light scatter (%) Light diffusion (cd/m²)/lx</p>	<p>Resistance to abrasion will be considered satisfactory if the light scatter as a result of abrasion does not exceed:-</p> <ul style="list-style-type: none"> • 2% for laminated glass windcreens (<i>Annex 6</i>) • 2% for laminated glass panes (<i>Annex 7</i>) • 4% for safety glass panes faced with plastic material (<i>Annex 9</i>) • 2% for the outer face of glass/plastic windcreens and panes and • 4% for the inner face of glass plastic windcreens and panes (<i>Annex 10 and</i> 	<p>The mean value of the light scatter through four repaired areas shall be not more than 4% above the value of the light scatter through the base glass. (8.7.1). 8% after exposure to high humidity. (8.7.2).</p>	<p>The light diffusion before abrasion shall not exceed 0.65 (cd/m²)/lx (test method a & c) or 2.5% (test method b) (7.8.3.2.1.2)</p> <p>Note: Reg 22 Abrasion test is by falling sand method)</p> <p>Following UV conditioning and abrasion the visor samples shall show a light scatter value not greater than 10% on either surface (BS 4110:1999</p>	<p>Light diffusion before abrasion =</p> <p>Single lens goggles (Type A) not to exceed 1 (cd/m²)/lx.</p> <p>Multiple lens goggles (Type B) not to exceed 2 (cd/m²)/lx. (<i>Table 1</i>)</p> <p>After abrasion test the goggles oculars shall have a reduced luminance factor of not more than 12 (cd/m²)/lx. (4.7.2)</p>	<p>When tested the reduced luminous coefficient of the filters in the new state shall not exceed the value of 0.65 (cd/m²)/lx (4.3)</p>

	11)		5.5) Note: Abrasion test by revolving wheel method)		
--	-----	--	--	--	--

Resistance to radiation	Total light transmittance does not fall below:- <ul style="list-style-type: none"> • 95% of the original value before irradiation for windscreens; • 70% in the case of panes other than windscreens • 75% in the case of windscreens in the zone (9.2.5) where regular transmittance is measured (6.3.1.1) 	The total luminous transmittance of the repaired area shall be >95% of the original value before irradiation, and not less than an absolute minimum value of 75%. (8.4)		Following irradiation the relative change in the luminous transmittance shall be less than $\pm 5\%$ for filters of category 0, less than $\pm 10\%$ for filters of category 1 and less than $\pm 20\%$ for filters of all other categories. (4.6)
-------------------------	--	---	--	--

Table 7. Sunglasses and goggle filter categories (Table 1 EN1836:1997 and Table 2 EN 1938:1999)

Filter category	Description	Range of luminous transmittance(τ_v) %	
0 Sunglasses	Clear or very light tint	80	100
1 Sunglasses	Light tint	43	80
2 Sunglasses	Medium tint	18	43
3 Sunglasses	Dark tint	8	18

4 Sunglasses	Very dark tint	3	8
1 Goggles		80	100
2 Goggles		43	80
3 Goggles		18	43



V_2



V_2

V_1

4°

V_2

V_1

4°

4°

4°

P-point	X	Y	Z
P ₁	+35mm	+20mm	+627mm
P ₂	+63mm	- 47mm	+627mm

	90°		60°	
	White	Red	White	Red
Clear	88%	85%	79%	75%
Tint	73%	60%	65%	49%



SAE minimum specification of 70% is not met

Endangers law enforcers (cannot see weapons)	32
Prevents eye contact between road users	24
Reduced visibility in darkened conditions	24
General reduced visibility	22
Data promoting increased transmission is not sufficient	18
Current technology is sufficient re: health hazards eg absorbing radiation	17
Promotes criminality	14
Viewing forward traffic through rear window of car in front is impeded	11
Reduced visibility to those with poor eyesight	9
No guaranteed benefits re: reduction of UV, infrared, reduced temperatures etc	8
No guarantee of improved safety eg reduced laceration, prevented ejection	6
Reduction of glare, haze etc not guaranteed	5
Fashion accessory	3

Transmission level	Acceptable rake angle
Untinted	67°
85%	61°
75%	20°

	Age	Years driving
Average	42	23
Minimum	21	4
Maximum	72	54

(Years)	Age of car	How long owned
Average	7.3	2.9
Minimum	2	0.1
Maximum	15	13

	General public		Professional	
	Age	Years riding	Age	Years riding
Average	41	15	39	20
Minimum	22	1	32	15
maximum	73	44	5	25

	General public	Professional
Up to 250cc	3	0
260 – 500cc	7	0
510 – 1000cc	16	1
Over 1000cc	2	13

	General public	Professional
Commuting	21	7
Professional	6	13
Leisure	34	14

	General public	Professional
Daily	13	13
Weekly	11	0
Monthly	4	1

Variable	Level	
Visor/goggle transmission	Clear 59% (Current), 18% (Requested), 43% (CEN goggles)	
Tint colour	Black/neutral, Blue, Yellow	
Signal light recognition	Red (traffic light or vehicle presence light - whichever is dimmer) Amber, Green	
Object detection	Small object	
Ambient road conditions	Busy street environment	
Ambient lighting	Daytime-dry Daytime-wet-fog Daytime-wet-glare Dusk/Dawn/overcast	Night-time (lit)-dry Night-time (unlit)-dry Night-time (unlit)-wet -fog Night-time (unlit)-wet-glare

Variable	Level
Transmission	75% Council Directive 92/22/EEC for windscreens 70% Council Directive 92/22/EEC for side and rear windows 53% , 37%, 22% (transmittance values for materials currently available on the market)
Rake	To be determined from survey - see section 7.2.1
Damage/repair	To be determined from survey - see section 7.2.2
Haze	To be determined from survey - see section 7.2.3
Abrasion	To be determined from survey - see section 7.2.4
Signal light recognition	Red (traffic light or vehicle presence light - whichever is dimmer) Amber, Green
Object detection	Small object
Ambient road conditions	Busy street environment

Ambient lighting	Daytime-dry Daytime-wet-fog Daytime-wet-glare Dusk/Dawn/overcast	Night-time (lit)-dry Night-time (unlit)-dry Night-time (unlit)-wet -fog Night-time (unlit)-wet-glare
------------------	---	---

Variable	Level
A-pillar thickness	To be determined from survey - see section 7.2.6
A-pillar position	To be determined from survey - see section 7.2.6
A-pillar rake	To be determined from survey - see section 7.2.6
Object detection	Small (ball) and large (child pedestrian)
Ambient road conditions	Busy street environment
Ambient lighting	Daytime-dry

	1999	2000					
	August	September	October	November	December	January	February
Surveys and prep							
Visor - Trial (1)							
Visor - Data analysis (1)							
Visor - Trial (2)							
Visor - Data analysis (2)							
A-pillar - Prep							
A-pillar - Trials							
A-pillar - Data analysis							
Visor survey							
Develop/cost new reqts							
Draft amendments to regs							
Report/Revision							

AUTHOR	TITLE	DATE	JOURNAL/SOURCE	PUBLISHER
Allen et al	Forensic aspects of vision and highway safety	1996		Lawyers & Judges Publishing Co, Inc
Allen, M J	Windscreen dirt and surface damage effects	1974	Australian Road Research Vol. 5, No. 6	
Bhise, V D	Visual search by			

	drivers in freeway merging: implications for vehicle design			
Burns, N.R. et al	Effects of car window tinting on visual performance: a comparison of elderly and young drivers	1999	Ergonomics, Vol 42, No.3, 428-443	
Charman, W N	Vision and Driving	1997	Road Safety Research Report No. 2	The Department of Transport
Chauhan K and Charman N	The Mandelbaum effect and night driving		Report and papers for Link-TIO	UMIST
Chmielarz, M et al	Vision-impairing wear of windshields	1988		
Chong, J et al	Visual Accommodation and target detection in the vicinity of a window post 1989	1989	Human Factors, 31(1), pp 63 - 75	The Human Factors Society
Clark, B A J	Visual handicaps allowed by road vehicle standards	1996		Defence Science & Tech Org.
Clark, B A J	Day-time hazards of windshield tinting	1993	Road & Transport Research	
Cooper, B R	Night-time seeing distances with tinted motorcycle helmet visors	1983	Working Paper	TRRL
Cunningham, g	After-market-film on passenger car windows and light transmission	1993	Vision in Vehicles	Elsevier Science Limited
Dain, SJ	Review of the visual issues related to tinted side automotive windows	1997	Pentagon Auto-Tint	University of New South Wales
Department of Transport	Proposed Manual on Motorcycle riding	1981		TRRL
Derkum, H	Effects of various transmission levels in windshields on perception	1994	Vision in Vehicles	Elsevier Science Limited
Enright A	Same is more: Audi's A4	1999	Article	The Times
Fosberry RAC and Mills BC	Measurements of the driver's visibility from private cars and commercial vehicles and some recommendations for minimum visibility requirements	1956	MIRA	
Fowkes, M	The legislative determination of the drivers field of view	1986	Vision in Vehicles	Elsevier Science Limited
Gittelsohn A M	Tinted windshields don't increase	1973	Automotive Engineering	

	accident risk			
Green P and Burgess WT	Windshield Damage and Driving Safety	1981	Final Report	The University of Michigan
Haase, O et al	Vision impairment by worn windshields during night-time driving			
Haslegrave, C.M.	Visual aspects in vehicle design		Automotive Ergonomics - Peacock and Karwowski	
Hayward J M & Marsh R J	Visual field restriction caused by motor cycle helmets	1988	Vision in Vehicles II eds. A. G. Gale et al	Elsevier Science Limited
Helmers, G and Lundkvist S-O	Detection distances to obstacles on the road seem through windscreens in different states of wear	1988	VTI rapport	Swedish Road and Traffic Research Institute
Hills, B	Tinted Windshields: Effects on visibility, thermal comfort and accident rates	1976		TRRL
Kebler, F R	Light diffusion characteristics and visibility interferences in automobile windshields	1993	Vision in Vehicles - IV eds. A. G. Gale et al	Elsevier Science Limited
Khalid, H M & Ooi, P C	Effects of motorcycle helmets on task performance and user acceptability	1996	Vision in Vehicles - V eds. A.G. Gale et al	Elsevier Science Limited
Klein, R.	Age-related eye disease, visual impairment, and driving in the elderly	1991	Human Factors 33(5), pp 521 - 525	The Human Factors Society
McKnight, A J & McKnight, A S	The effects of motorcycle helmets upon seeing and hearing	1994	Accident Analysis and Prevention, Vol.27, No.4, pp493-501	Elsevier Science Limited
McLean, A J et al	Adelaide in-depth accident study 1975 - 1979	1979		The University of Adelaide
Morris, A et al	Visual acuity of the US navy jet pilot and the use of the helmet sun visor	1991	Aviation, Space and Environmental Medicine	Aerospace Medical Association
Mukherjee, P	Car Window Tinting - a Consultative Document	1997	Supplement	
Olson, P.L.	Visibility problems in nighttime driving	1987	SAE Technical Papers	SAE
Olson, P.L.	Forensic aspects of driver perception and response	1996		Lawyers & Judges Publishing Co, Inc
Phillips, A J & Rutstein A	Glare - A study into glare recovery time with night driving	1965	The British Journal of Physiological Optics Vol. 22, No. 3	British Optical Association

	spectacles			
Porter, J M & Stearn, M C	A technique for the comparative assessment of external visibility characteristics in road vehicles	1986	Vision in Vehicles	Elsevier Science Limited
Proffitt, D.R. et al	The effect of reduced transmittance window tinting on drivers' ability to detect targets in their rear-view mirrors	1996		Virginia department of transportation
Rompe K & Engel G.	The influence of windshields with low light transmission in driver's vision	1987	SAE Technical Papers	SAE
RoSPA	Starting off		Guide to Safer Motorcycling	RoSPA
Sayer, J R & Traube E C	Factors influencing visibility through motor vehicle windshields	1994	US Department of Commerce NTIS	UMTRI
Slade, S V and Dunne MCM	Visual acuity, voluntary driving restriction and road crashes	1996		Aston University
Snook, S.	Automotive Glass	1998	Engineering	
Taylor J F	Tinted glazing on vehicles			
Timmermann, A.	Direct measurement of windscreen surface wear and the consequences for road safety	1986	Vision in Vehicles	Elsevier Science Limited
Timmermann, A.	Reduction in vision through used crash-helmet visors	1985	Research Institute of Auto-Sicht	TRRL
Timmermann, A.	An instrument to measure scattered light due to windshield wear			
Unknown	Speed related severity of injury to motorcyclists - visors			
Unknown	The DETR Rational against a reduction in minimum light transmittance	1979	BS 4110	BSI
Unknown	Through the glass darkly	1997	Motor cycle Rider	
Unknown	Research Frontiers grants licence to ... to manufacture and sell for making variable transmission films for "smart windows" ...	1999	Research Frontiers	Press Release

Vaughan, n et al	Development of an objective method for assessing the fogging of complete eye protectors; Final report			EC funded project MAT1-CT 940042
Waters PE	The effects of tinting and abrasion of motorcyclists visors on night time vision	1982	BSI draft document	
Weigt, P	Darker glasses in the rearward field of view	1986	Vision in Vehicles	Elsevier Science Limited
Wigan M R	Towards improved standards for automotive eye protection	1979	Australian Journal of Optometry 62.8	
Zwahlen, H.T. & Schnell, T.	Visibility through tinted automobile windshields at night	1994	Ergonomics and Design, Vol 4	IEA

Organisation	Contact	Notes
ACPO	Mr Hugh Alford	Not yet contacted
Metropolitan Police	PC Ian Kerr	For category 2 visors for daytime use. Would like to see it made a statutory offence under RVL R to wear during hours of darkness. See letter to BS of 22 Dec 95
South Yorkshire Police	PC Mick Logan Accident Investigation Branch	Using Tintman - 200 vehs tested and on database.
Police Traffic	PC Steve Hume	Have replaced Fog City interior visor film with Pinlock which has been very good at anti-misting.
Brian Langar	Not contacted AA views obtained via David Lang	
AA	Andrew Howard	Not contacted AA views obtained via David Lang
AA	David Lang Chief Engineer	On BS PH/2/5 committee. In favour of category 2 filters
RAC	Paul Evans Technical Services Engineer	On BS PH/2/5 committee. In favour of category 2 filters (see letter to Cathy Bassey, 16 Sept 97)
BMF	Trevor Magner	See note below
ACU	Geoff Lovatt Road race and Technical Secretary	Not contacted - obtained letter via Bob Heath : For category 2 filters. Mainly concerned with racing but also that if BS4110 is not amended road and race riders will still obtain visors that are not certified. See letter to BS 25th Sept 97.
RoSPA	Kevin Clinton Project Manager (Road Safety)	Kevin sent letter 5/7 confirming and copying previous letters (April & June 97): Does not consider category 2 visors would cause problems for a rider with good vision no spectacles or contact lenses. But has concerns that they would be used in unsuitable conditions.

Trading Standards LACOTS	Alison Edwards	To be contacted re enforcement at point of sale
BSI	Miss Cathy Bassey Project Manager Secretary to PH/2/5	Has circulated members with details of project and request for assistance. BS4110 1999 is latest. Changes to abrasion not tints. No tinting work ongoing.
BSi Testing	Alan Harding (PPE)	DS visited. Has just done some work for DETR on abrasion. Results provided. Demonstrated test equip for visors.
BSi Testing	Paul Parkins (Windscreens)	
BSi PH/2/5	Alan Goodman Ex BSI testing	
BSI	John Bowlt Chair BS PH/2/5	sunglasses expert, BSI committee member (chair) Confirmed view of committee. Papers available if required
Chair BS PH/2 & member PH/2/5	Paul Clarke Inspec Laboratories Ltd	Provided information on Sunglasses standards Misting test is comparative but in Paul's view questionable.
CEN	Ernest Suter Chair TC85 WG1 – sunglasses TC WG5 visors	Developed drop grit test – has sent us details of the background to this new form of abrasion test.

Glazing industry

Pilkingtons (Triplex)	Peter Pennells	To be contacted
Glass and Glazing Federation	Stephen Rice Technical Officer	To be contacted
Pilkington special glass ltd	Chris Rogers Member of BSI committee PH/2 - eye protection	Pilkington special glass manufacture sunglasses for use when driving and may be interested in participating in the study. Re: traffic light signal recognition etc, set out in European sunglasses standard BS EN 1836.

Vehicle glazing repairers/tinters

Pentagon Auto-tint	Peter Mukherjee Director	Demonstrated car window tinting and provided information on materials, reasons for tinting and research on tinting effects.
Auto Glass	Steve Eccleston Quality Manager	Will demonstrate repairs etc. Liaises with AA, RAC, Halfords and Pilkington on quality control.
Save-a screen	Marcel	Self employed one-man business based in Shepshed. Can supply used windscreens for tests and demonstrate repairs.

Motorcycle helmet, visor and goggle manufacturers

Motor Cycle Industry Association Ltd	F Finch Marketing Services Manager Mark Foster Chief Executive Nick Brown Researcher	Mr Finch is on BS PH/2/5 committee. In favour of Category 2. Make it illegal to wear a visor less than 80% in dark or poor light. Mark the visors to help enforcement. See letter to committee of 7 Aug 1997
Bob Heath Visors	Bob Heath	Meeting held. Views as per others on BS committee for visors

Researchers		
UMIST	Prof. W.N. Charman	Wrote review report on vision and driving. Contacted for opinions and current relevant work and contacts.
TRL	Brian Hills/Bryan Cooper/ Brian Chin (helmets)	Consulted regarding previous visor vision test
Aston University	Colin Fowler Director of Clinical Studies	Contacted for opinions and current relevant work and contacts.
Aston University	Dr Mark C M Dunne PhD MCOptom	Contacted for opinions and current relevant work and contacts.
Health and Safety Laboratories Sheffield	Nick Vaughan	Has been co-ordinating a EC-funded research project on assessing resistance of eye protectors to fogging by condensed moisture, which may be relevant. So far the work has only considered goggles and spectacles, but some of the principles and techniques may be common to visors.

	Age	Years driving
Average	42	23
Minimum	21	4
Maximum	72	54

(Years)	Age of car	How long owned
Average	7.3	2.9
Minimum	2	0.1
Maximum	15	13

No	Yes
27	3

never	8
rarely	1
sometimes	18
often	3

- Cold weather
- Cold weather
- At night
- In winter - cold weather outside and people breathing condensation
- Raining & cold
- winter
- Cold days, evenings worse
- very cold and have heaters on
- Cold weather
- Clears very quickly
- Winter od Summer rain
- Early morning
- Early morning
- Winter mornings
- Cold outside, damp people inside
- Rain
- cold early mornings
- Cold, rain
- back windscreen & front when raining
- cold
- Muggy or damp weather
- Winter, cold
- Rain, cold and damp people in car

Fan	20
cloth	1
hand	0
other	1

never	8
rarely	6
sometimes	6
often	1

Within the last week	7
Within the last month	13
Within the last 3 months	4
Longer	2

- Only did it once - keep fan on until clear and keep on to keep clear
- If fan on then clears throughout drive (until clear)
- When mists up

- If very cold with lots of people in the car
- Wait until gone
- Won't drive if can't see
- Leave fan/heater on until clear
- Rain
- use hand or leave fan on
- only initially when set off

Routinely	8
when dirty	21

never	20
rarely	3
sometimes	7
often	0

- blobs in line of sight
- Glare from sun
- Dazzle, blobs in line of vision
- Momentarily - wipe away as drive
- Keep cloth in car
- Smears can scatter glare and make it worse
- Night-time, oncoming cars - dazzle rain, lessened vision
- reduced visibility, especially in daylight, low sun

never	8
rarely	1
sometimes	16
often	4

- My eyes are very susceptible to bright lights so I wear prescribed distance sunglasses
- impossible to see due to glare off road - one occasion
- Temporary blinded, slow down
- Dazzle, reflected dazzle from other car windows, squint if very bright
- If in your eyes
- Glare - real problem. Winter sunshine very bad
- Glare
- glare
- Glare, not able to see
- Adjust eyes
- Glare
- Would if not wear sunglasses

- Always wear sunglasses
- Too bright
- dazzle from low sun and reflected sun
- Glare - reflection of dashboard onto windscreen
- wear cap
- Can't see, glare
- Dazzle
- glare
- low sun cases glare & dazzle

- Wear sunglasses & use visor
- see previous
- visor down, drove slowly
- Put visor down
- Use visor flap, squint if necessary
- Put visor down, wear sunglasses
- Put sunglasses on (paler in middle) - make sure glass demisted before set off - anticipatory action
- Sunglasses
- Put visor down to prevent it
- Always drive with visor down
- Put visor down
- Wear sunglasses, pull visor down
- Sunglasses
- Sunglasses
- wear sunglasses and pull down visor
- Visor down, squint, slow down
- Squint
- visor down, put on sunglasses
- Visor down
- visor down
- put visor down and sunglasses on
- put visor down, other visor on passenger side as well if it helps. Slow down and concentrate on road immediately in front.

No	21
Yes	1

Yes	8
No	19

- All windows tinted grey
- rear and side rear windows grey
- All of them, green on top windscreen. All a bit grey

- Slight tint, grey
- Slight tint, grey
- Windscreen tinted at top - green others just slightly grey
- Top of windscreen is blue
- all greyish

Yes	8
No	0

Yes	1
No	7

Yes	13
No	7

- front
- At top of windscreen
- Never seen any to compare with
- Windscreen
- Windscreen, all of them
- have tinted windows in other car, paid to put them in. Don't use this car for long journeys
- Windscreen and front sides
- Side & back possible mild tint on front to help glare
- All of them
- Look tacky
- Windscreen and side windows
- All
- just a fashion thing to have tinted. Like to keep colours and brightness as they are, mesopic times of day want as much light as possible (as at night)
- Windscreen
- Windscreen
- all of them
- windscreen
- To help stop glare
- Only at top, not get in way of vision - would be a problem if tinted at sides of windscreen
- If it would cut down glare, not matter for rest
- would do back ones if had children
- Reduce glare
- Car too old
- Like tinted windows. But might reduce visibility if front ones done
- Save wearing sunglasses

- Reduce glare into driver and front and back passengers
- had before & liked them
- to reduce glare
- reduce glare
- have had tinted windows in previous car and liked them

never	13
rarely	5
sometimes	7
often	4

- Turning 90degrees onto other road
- Roundabouts
- Punto always restricted vision - Ford Escort roundabouts cause problems
- Tight T junctions, when leaning forward to see
- Turning right at T junctions, leaning forward, small angle to see left between tak stickers, pillar and rear-view mirror
- Quite narrow
- Turning onto major road
- Are very thin on this car
- Turning right
- back ones more a problem
- 90degree turns, pulling out onto dual carriageways off slip roads
- Two cars approaching junction - one obscured and roundabouts
- Looking right for 90 degree junction
- reversing into spaces - difficult judge where sides are
- Roundabouts or corners
- twisty bends

never	11
rarely	4
sometimes	10
often	4

- Roundabouts & reversing
- When peering round 90degree turns
- Roundabouts
- sit back and look through side window instead
- A little bit, when turning
- will do at some point
- Might do but unaware
- as previous plus when parking
- have learnt to do it . Saab was worst car for it
- parking

- twisty bends
- sign posts when stationery

same	10
better	8
worse	5

- Better than older Polo
- Worse than mini, better than punto
- Similar
- Later versions of same car were improved. Other Volvos also better
- Narrower than newer cars driven
- Better than older cars
- Never really noticed
- better than Ford Mondeo
- Worse than small cars - Nova
- No difference
- better than Saab
- better than Nissan Micra
- Never really been a problem
- Mazda about average. Saab was worse
- Worse than Toyota starlet
- is wider than escort
- same as other Rovers, better than some others
- only ever had Renault

Yes	2
No	27

	General public		Professional	
	Age	Years riding	Age	Years riding
Average	41	15	39	20
Minimum	22	1	32	15
maximum	73	44	5	25

	General public	Professional
Upto 250cc	3	0
260 – 500cc	7	0
510 – 1000cc	16	1
Over 1000cc	2	13

	General public	Professional
Commuting	21	7

Professional	6	13
Leisure	34	14

	General public	Professional
Daily	13	13
Weekly	11	0
Monthly	4	1

	General public	Professional
None	21	5
BMF	1	2
Institute of Advanced Motorcyclists	1	6
Blue Knight Motorcycle Club	0	2
Kent Advanced Motorcycle Group	2	0
Kawasaki Riders Club	2	0
Ducati Club	1	0

	General public	Professional
None	5	1
Motor Cycle News	12	8
Ride	3	3
Bike	6	7
Performance Bike	7	1
Superbikes	3	1
Motorcycle Sport	0	1
Classic Bike	2	0
The Classic Motorcycle	2	0
Streetfighter	2	0
Other	2	0

	General public	Professional
Helmet		
Full face	28	14
Open face	0	0
Other	0	0
Eye protection		
Visor	28	14
Goggles	0	0
other	0	0

Months	General public	Professional

Average	20	21
Newest	1	1
Oldest	96	60

	Professional			
	Never	Rarely	Sometimes	Often
Rain	0	0	1	13
Darkness	0	0	1	13
Bright sunlight	0	0	2	12
Fog/mist	0	1	7	6
Snow	1	7	0	1

- Misting!
- rain blurs vision on visor at low speeds and can get through vents onto inside of the visor where it cant be wiped clear
- rain - vision obscured droplets/misting Fog - misting/condensation
- Bright sunlight causes problems, due to having no sun visor to pull down. Sunglasses are uncomfortable and may affect BS Standards in impact? rain droplets/mist on o/s of visor can be a problem especially at night.
- Problems in bright sunlight with clear visor - glare from sun, so sunglasses worn under visor
- In rain visors fog up, Bright sunlight you require proper sunglasses, snow conditions dazzle at times
- Difficult in rain in slow riding conditions - at speed wind throws rain droplets off
- Visor misting tried fog city made a small improvement
- steaming up
- misting

	General public			
	Never	Rarely	Sometimes	Often
Rain	3	9	8	8
Darkness	2	8	11	7
Bright sunlight	0	1	6	21
Fog/mist	8	6	8	6
Snow	17	6	0	4

- None other than traditionally associated with motor cycles
- Limited vision at night
- before tinted visors, low sun caused problems
- Chose tinted visor to avoid glare from sunlight
- Simpson visor v dark
- Misting up is a problem, under fog/mist and sometimes under rain. Dead flies are a problem sometimes and long journeys in the summer.
- clear visor will repleat in sun and steam in rain

- rain - visor steams up and lift visor so you get rain in your face and still cant see. Rain & dark, droplets and you get 10000 sets of headlights coming towards you
- glasses often uncomfortable with helmet and when raining need windscreen wipers when sunny need to change to sunglasses

	General public	Professional
Often	5	4
Sometimes	11	9
Rarely	3	1
Never	8	0

- Cold days - Wet conditions water running down inside of visor
- Usually conditions or rain when the rider is relatively warm. It is necessary to then with the visor up to see the road ahead or to attempt to clear the fogging the eyes are then unprotected
- Fog/Mist/rain constant wiping of outside surface with glove - distancing from attention on road
- Visor always mists during cold and wet weather when fully closed
- Visions of mist up in rain/fog and on cool damp mornings, Help up at junctions/lights/traffic. Not normally too bad whilst on move. I usually keep visor slightly open for ventilation.
- Early morning(using helmet when coming out of the warm home into cold air) heavy rain falls, winter riding
- Heavy rain
- I use a fogcity - Very Good
- I use a fogcity
- When damp or early morning
- Bad weather conditions
- rain
- Use washing up liquid
- when riding in town
- cold autumn nights
- winter evenings
- In winter waiting at traffic lights, junctions etc.
- anti-fog helmet
- rain
- cold and hot weather - condensation and perspiration
- rain, fog and night
- In traffic, put visor up to help see, then when put it down it's wet inside
- Insert to prevent air form nose & mouth reaching visor - anti-fog mask
- cold
- wet weather
- rain or cold
- especially if raining hard

- If visor doesn't mist, glasses often do

	General public	Professional
Often	2	0
Sometimes	7	1
Rarely	3	7
Never	16	6

	General public	Professional
Often	5	5
Sometimes	14	6
Rarely	0	1
Never	9	2

	General public	Professional
Yes	24	11
No	0	2
Don't know	4	1

	General public	Professional
Yes	12	1
No	16	13

	General public	Professional
Yes	16	8
No	12	6

	General public	Professional
Yes	14	6
No	14	8

	General public	Professional
Yes	18	11
No	10	3

	General public	Professional
not done	4	0
very easy	11	9
easy	7	2
acceptable	2	3
difficult	4	0

very difficult	0	0
----------------	---	---

	General public	Professional
Yes	22	14
No	6	0