



This item was submitted to Loughborough's Institutional Repository (<https://dspace.lboro.ac.uk/>) by the author and is made available under the following Creative Commons Licence conditions.

  
C O M M O N S D E E D

**Attribution-NonCommercial-NoDerivs 2.5**

**You are free:**

- to copy, distribute, display, and perform the work

**Under the following conditions:**

 **Attribution.** You must attribute the work in the manner specified by the author or licensor.

 **Noncommercial.** You may not use this work for commercial purposes.

 **No Derivative Works.** You may not alter, transform, or build upon this work.

- For any reuse or distribution, you must make clear to others the license terms of this work.
- Any of these conditions can be waived if you get permission from the copyright holder.

**Your fair use and other rights are in no way affected by the above.**

This is a human-readable summary of the [Legal Code \(the full license\)](#).

[Disclaimer](#) 

For the full text of this licence, please go to:  
<http://creativecommons.org/licenses/by-nc-nd/2.5/>

# Uncertainty in Model Based Condition Monitoring

R.A.Buswell and J.A.Wright

## Abstract

Model based techniques for automated condition monitoring of HVAC systems have been under development for some years. The generation of false alarms has been identified as a principal factor affecting the potential usefulness of condition monitoring in HVAC applications. Results from the application of these methods to systems installed in real buildings have highlighted the difficulty in selecting good alarm thresholds that balance robustness (lack of false alarms) and sensitivity (early detection). This paper demonstrates that this balance can be met in a transparent and analytical manner, through the application of uncertainty analysis. The paper discusses the sources of uncertainty associated with component models and system measurements. A Condition Monitoring scheme applied to a typical HVAC cooling coil subsystem installed in a real building is presented. Faults are artificially introduced into the system and are used in conjunction with fault-free operation to demonstrate the sensitivity and robustness of the scheme. The principle conclusions drawn by the paper consider the likely minimum magnitudes of faults that can be detected in typical HVAC systems, without false alarm generation. More broadly however, the paper demonstrates that the issue of uncertainty affects all aspects of system monitoring, modelling and control.

**Key Words:** Uncertainty Analysis, Model Uncertainty, Model Structure, Measurement Uncertainty, Fault Detection, Condition Monitoring, Air-Conditioning, Heat Exchanger, Physical Modelling, Sensors, HVAC, Information Poor Systems.

## Introduction

Over recent years there have been considerable research efforts into developing condition monitoring technologies for HVAC equipment. Many approaches have been developed, including the application of fuzzy logic, artificial neural networks, parameter estimation, rule bases and hybrid approaches, such as combining physical modelling techniques with radial basis function networks. At the forefront of this research has been the work of Annex 25 of the International Energy Agency (IEA) (Hyvärinen, 1997a). The developed approaches were generally evaluated using simulation methods. Subsequently, IEA Annex 34 (Dexter and Pakenen, 2001) investigated the practical application and demonstration of some of the technologies developed in Annex 25. The work demonstrated that the following requirements are important for the successful implementation of condition monitoring in real HVAC systems:

- low rate of false alarms;
- quick detection of developing faults;

Table 1: Sources of Uncertainty Associated with General Uncertainty Categories

Measurements	Model Structure
sensor	detail
data handling	assumptions
noise	configuration data

- robust to atypical disturbances.

One of the contributing projects to IEA Annex 34 applied different fault detection and diagnosis techniques to several HVAC subsystems (Norford et al., 2000; Norford et al., 2002). With respect to the detection of faults, the main issues were demonstrated to be:

- in general, abrupt faults could be detected;
- in general, degradation faults had to be quite large before detection was unambiguous;
- and the reliability measures used, were not sufficiently robust, hampering the ‘fault alarm’ threshold selection.

Highly uncertain measurements and the lack of experimental control that exist in real HVAC plant are the cause of these problems. The effectiveness of any model based condition monitoring scheme, is therefore dependent on the magnitude of uncertainty in both the measurements and models (Buswell, 2001).

This paper describes the sources the uncertainty in terms of the measurements and first principles based models. A condition monitoring scheme that accounts for all these uncertainties is described and applied to a cooling coil subsystem installed in a real system. The conclusions are focused on the minimum fault magnitude that can be detected without false alarm. Demonstrated throughout, is that uncertainty does affect all aspects of system monitoring, modelling and control.

## Sources of Uncertainty

Figure 1 maps the uncertainty flow path of a model based condition monitoring scheme where the prediction error is used as the fault presence indicator. The sources of uncertainty that influence the sensitivity and robustness of a model based condition monitoring scheme can be attributed to the measurements and the model structure. Table 1 lists the sources of uncertainty in these two categories. Influences on the sensor uncertainties are; type and design; published characteristic/conversion tables; associated dynamics; and age. Data handling is affected by; installation (Son, 1998); data handling, such as truncation and rounding; and analogue to digital conversion. Measurement noise can be influenced by; flow rate and flow regime in terms of the heat transfer coefficient at the sensing element; radiation, from other surfaces such as coils, or the sun; approximation to the mean fluid temperature that is implied by the measurement; and noise induced in the analogue signal by external factors (Oughton, 1985). The uncertainty in the model structure can be influenced by the level of model complexity; model simplification implies some approximation of the process in the

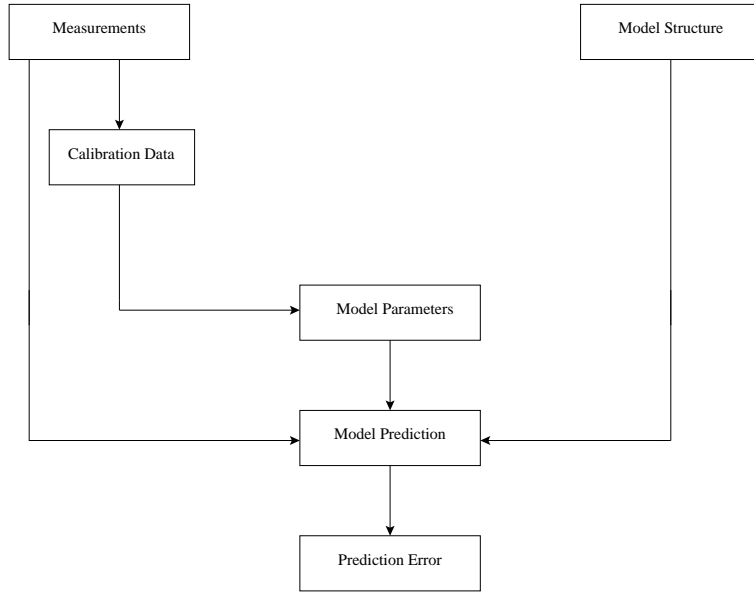

Figure 1: Condition Monitoring Scheme Uncertainty Flow Diagram.

model description and can result uncertainty. Often assumptions are required to simplify a process description, i.e. an homogeneous air condition into a coil. The uncertainty may be accounted for in the measurement uncertainty, but it may also influence some aspect of the estimated uncertainty in the heat transfer process calculations in the model. The configuration data has a strong influence on the uncertainty in the model because this is where the data uncertainty (measurement uncertainty in particular) is assimilated. This is especially important where models require calibration from system data. Typically, the data available from HVAC systems for model calibration purposes are not from the complete range of operation. Considerations over the uncertainty in the resulting calibrated model with respect to the expected operating range (extrapolation), therefore, also requires prudence.

A final consideration is required when steady-state models are used with data containing transients. If transients are present in data, then the model predictions will be degraded. The unwanted data can be filtered out, or included in the calculations with the necessary increase the uncertainty magnitude.

The uncertainty in the prediction error is estimated by propagating the input measurement and model structural uncertainties through the whole condition monitoring scheme. Using the method established by Kline and McClintock (1953), the uncertainty in the system output can be estimated by,

$$U_y^2 = B_y^2 + P_y^2 + R_y^2, \quad (1)$$

where,  $U_y$  is the 95% estimate of uncertainty in the prediction error,  $y$ .  $B$  represents the estimate of the bias uncertainty present in the measurements.  $P$  represents the random uncertainty in the measurements and includes the estimation of uncertainty associated with using steady-state models with data containing transients.  $R$  represents the uncertainty in the model structure and the uncertainty from the model calibration process. All three contributions are estimated at the 95% confidence level and are discussed in more detail in the following sections.

## Bias Uncertainty in the Measurements

Information from HVAC systems is readily available by monitoring the measurements used for control. Model based condition monitoring methods often rely on these measurements, and not on special, additional instrumentation, for economical reasons. This reduces the level experimental control and can therefore increase the uncertainty in condition monitoring schemes. Bias in the measurements should be minimised and a methodology for accomplishing this keeping the sensors *in-situ*, is given in (Buswell, 2001). Some bias uncertainty will always exist in the measurements and is principally attributed to:

- instrumentation, calibration and data gathering;
- measurement representation of the ‘bulk’ average property or quantity of a fluid.

Data gathering operations are usually an in-built feature of HVAC control systems. The former issue can be resolved by a review of the system documentation and by the employment of typical calibration procedures. Depending on the fluid and measurement, the latter issue is more difficult to quantify. The most significant effect in air temperature measurements is stratification. There is little published work investigating these problems, excepting Carling and Isaksson (1999) and Johnson et al. (1998), and some guide lines are given in Buswell (2001).

Although uncertainty needs to be reviewed on a case-by-case basis, the characteristics of the test system reported in this paper are typical of those in the majority of HVAC systems. It can be expected that these uncertainties will remain the key influences in most HVAC systems. In addition, many of the models used in HVAC calculations are not spatially distributed, and so the lumped representation of the fluid’s properties and quantities will generally be an important influence on model prediction uncertainty.

Using a development of the method established by Kline and McClintock (1953), given by Coleman and Steele (1995), the measurement bias uncertainty contribution,  $B_y^2$ , in Equation 1 is given by,

$$B_y^2 = \sum_{i=1}^J \theta_i^2 B_i^2 + 2 \sum_{i=1}^{J-1} \sum_{k=i+1}^J \theta_i \theta_k \rho_{B_{ik}} B_i B_k. \quad (2)$$

where  $B$  represents the 95% estimates of the bias uncertainties in the measurements,  $J$  is the number of variables and  $\theta_i = \frac{\partial y}{\partial x_i}$ . Given the standard deviation  $S_i$  and assuming the large sample assumption is applicable,  $P_i = 2S_i$ .  $\rho_{B_{ik}}$  is the correlation coefficient that relates the correlations between uncertainty sources.

## Random Uncertainty and Transient Data

Steady state models are often considered over dynamic model because of their simplicity. When transients are present in the data, model predictions can be poor. The unwanted data can be discarded using a filtering technique and has been a common approach (Hyvärinen, 1997b). These ‘steady-state detectors’ typically require thresholds and parameters to be set, and these can be difficult to tune to ensure good performance. An alternative is to consider transient data and estimate a suitable magnitude of uncertainty proportional to the transient effects on the model output.

Using a fixed time window, the mean and variance for each input variable is calculated. The mean values form the inputs to the scheme. The variance associated with each variable

is a measure of the magnitude of the random uncertainty contribution. An exponential relationship is applied to relate the variance to the uncertainty magnitude due to the transients. The relationship tends to a minimum as the system approaches steady-state. Minimum and maximum values of variance are estimated from the operating range of each variable. This allows the exponential relationship to be normalised and therefore applicable to all variables. Although there are a number of parameters to establish, the selection of maximum variance can be conservative and the approach is not sensitive to their values. The minimum variance is simple to establish from system data. The contribution to  $U_y^2$  is given as,

$$P_y^2 = \sum_{i=1}^J \theta_i^2 P_i^2,$$

where  $P_i^2$  is the uncertainty adjusted for the presence of transients (See Buswell (2001) for further details).

## Uncertainty in the Model Structure

The assessment of model structural uncertainty is an issue that has not been addressed in the literature. The simplifications and assumptions that allow the construction of simple models must by definition contain some uncertainty. These simplifications are based on information about the system. The quality and understanding of this information will, therefore, influence the uncertainty evaluation process. Uncertainty can also be present where iterations are required to solve model's equations. The convergence criteria introduces some uncertainty into the model prediction, however, this can usually be set to have a negligible impact on the uncertainty in the output.

There are two models used in the scheme; an SHR- $\varepsilon$ - $N_{tu}$  water to air heat-exchanger model (based on the Holmes (1982) model) and a first principles based model of a three port control valve and actuator. The models are similar to those in (Buswell et al., 2002). The SHR- $\varepsilon$ - $N_{tu}$  model requires one parameter to be selected. The valve and actuator model are calibrated through the adjustment of a number of parameters according to some test data.

Given the implemented model configuration, the uncertainty in the SHR- $\varepsilon$ - $N_{tu}$  model is present in the;

- cross-flow/counter-flow approximation in this class of coil;
- convergence criteria;
- physical constants;
- fluid flow regimes;
- resistance (to heat transfer) parameters;
- treatment of mass transfer.

A full discussion of the uncertainty is discussed in Buswell (2001). The uncertainty attributed to the model structure and parameters is given by,

$$R_y^2 = \sum_{i=1}^J \theta_i^2 R_i^2,$$

where  $R_i$  are the uncertainty contributions.

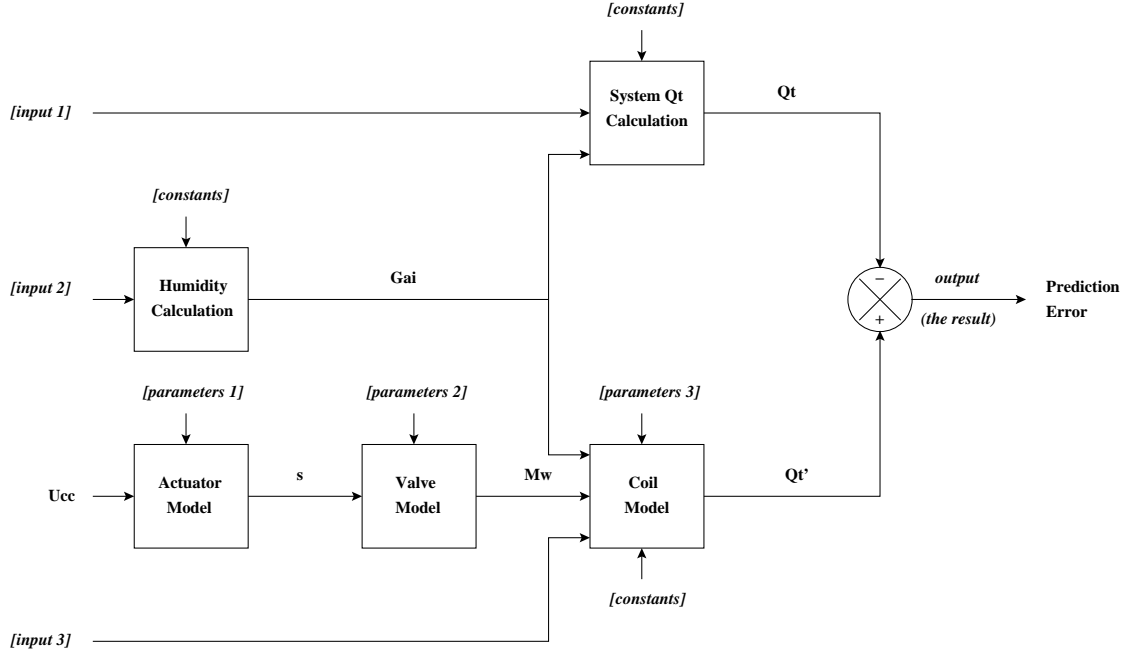

Figure 2: Information Flow Diagram for the Condition Monitoring Scheme.

## The Condition Monitoring Scheme

Model based condition monitoring compares the measured performance of the target system with a model that describes the system operating correctly. The difference between the model output and the actual system output is the ‘prediction error’ or ‘residual’. The significance of the prediction error indicates whether the system can be regarded as operating correctly or not. The uncertainties in the model structure, model parameters, measurements and in the system’s proximity to steady-state are used to ascertain the uncertainty in the prediction error. If the confidence limits, given by the uncertainty  $\pm U_y$ , about the prediction error,  $y$ , are such that  $y - U_y < 0.0\text{kW} < y + U_y$ , the system is operating correctly. If  $y - U_y > 0.0\text{kW}$  or  $y + U_y < 0.0\text{kW}$  then the system performance is significantly different from that predicted by the model. The system operation is therefore abnormal, and, for the purposes of this research, is considered to indicate the presence of a fault in the system<sup>1</sup>.

Figure 2 depicts the information flow diagram for the proposed condition monitoring scheme. The parenthesis indicates arrays of data, detailed in Table 2.  $u_{cc}$ ,  $s$ ,  $\dot{m}_w$ ,  $G_{ai}$ ,  $Q_t$  and  $Q'_t$  refer to the control signal to the cooling coil, valve stem position, water mass flow rate ( $\text{kg s}^{-1}$ ), humidity ratio of the air onto the coil ( $\text{kg kg}^{-1}$ ), actual total heat transfer and predicted total heat transfer (kW), respectively. The ‘humidity calculation’ block generates the humidity ratio of the air into the coil using the ratio of the outside air,  $V_{aa}$  ( $\text{m}^3\text{s}^{-1}$ ), to return air,  $V_{sa}$ ,  $j$ , in the supply air stream given by,  $j = V_{aa}/V_{sa}$ . The ‘system  $Q_t$  calculation’ block represents the air side total heat transfer calculation,  $Q_t = \dot{m}_a (h_{ai} - h_{ao})$ , where  $h_{ai}$  and  $h_{ao}$  are the air inlet and outlet enthalpies respectively ( $\text{kJ kg}^{-1}$ ).

<sup>1</sup>Generally the existence of a fault is conditional on there being some cost/benefit associated with correcting the abnormal behaviour (T. M. Rossi, 1994).

Table 2: Arrays of Input Data in the Condition Monitoring Scheme.

Input 1	Input 2	Input 3	Param. 1	Param. 2	Param. 3	Constants
$\dot{V}_{sa}$	$\dot{V}_{sa}$	$\dot{V}_{sa}$	$\omega$	$\beta$	$S_{UA}$	$Cp_a$
$T_{sa}$	$\dot{V}_{aa}$	$T_{ai}$	$a_l$	$\gamma$	$l_w$	$Cp_w$
$T_{ai}$	$T_{aa}$	$T_{wi}$	$a_h$	$\dot{m}_{w_{max}}$	$l_h$	$\rho_a$
$T_{ao}$	$T_{ra}$	-	-	-	$d_t$	$\rho_w$
$H_{sa}$	$H_{aa}$	-	-	-	$n_r$	-
-	$H_{ra}$	-	-	-	$n_c$	-
-	-	-	-	-	$r_a$	-
-	-	-	-	-	$R_m$	-
-	-	-	-	-	$r_w$	-

The reference model of the cooling coil subsystem predicts the total heat transferred in the heat exchange process. The subsystem model consists of component models of the control valve, actuator and heat-exchanger (similar to those described in Buswell et al. (2002)). The reference model is calibrated to more precisely represent the test subsystem. This is achieved by the adjustment of a number of parameters. The parameters are estimated by inspection of the equipment, design information and training data. The training data is generated by open loop tests that step the system throughout the range of operation.  $\omega$ ,  $a_l$ ,  $a_h$ ,  $\gamma$  and  $\beta$  represent the actuator and valve parameters relating to hysteresis, low activation point, high activation point, valve authority and valve curvature characteristic. The  $UA$  scaling factor,  $S_{UA}$ , is dimensionless and describes the increase/decrease in the  $UA$  ( $WK^{-1}$ ) of the target coil with respect to a reference coil at 100% duty. These five parameters are estimated from the training data after the other parameters listed in Table 2 have been established. These parameters,  $l_w$ ,  $l_h$ ,  $d_t$ ,  $n_r$ ,  $n_c$ ,  $R_m$ ,  $r_a$  and  $r_w$ , are respectively; the length and width of the coil (m), the tube diameter (m), the number of rows and circuits the resistance to heat transfer of the tube material ( $_{(rows)}m^2KW^{-1}$ ), the heat transfer resistance coefficients for the air and water sides ( $_{(rows)}Km^2s^{0.8}W^{-1}m^{-\nu}$ ).  $Cp_a$ ,  $Cp_w$ ,  $\rho_a$  and  $\rho_w$  represent the fluid specific heat capacities ( $Jkg^{-1}K^{-1}$ ) and densities ( $kgm^{-3}$ ).

The condition monitoring scheme generates an alarm when the prediction error becomes significantly non-zero. There must be a flow of air over the coil and water flow through the primary circuit if the measurements are to be applicable to the calculations. The scheme, therefore, only allows alerts to a significant change in system operation when the fluid mass flow rates are non-zero.

## The Test System

The system was a full size test facility, described in (Norford et al., 2000). The nominally rated 35kW cooling coil subsystem formed part of a variable-air-volume air-handling unit serving test zones. Figure 3 depicts the system. Air temperature measurement was available either side of the coil,  $T_{ai}$  and  $T_{ao}$  ( $^{\circ}C$ ). Air volumetric flow rate measurements are available on the return air,  $\dot{V}_{ra}$ , ambient,  $\dot{V}_{aa}$ , and supply air,  $\dot{V}_{sa}$ , paths. The relative humidity and temperature (local to the humidity sensors) measurements are available for the recirculated,



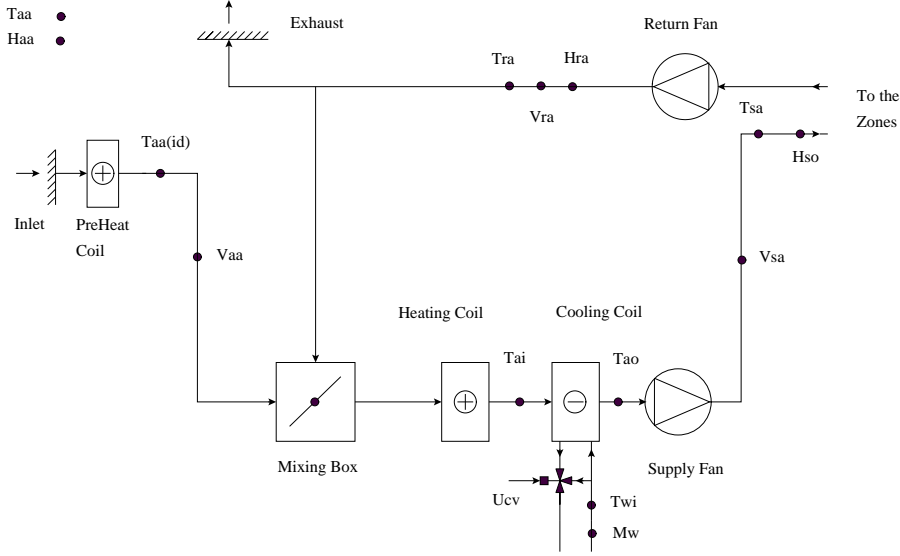

Figure 3: The Test subsystem.

$H_{ra}$  (%) and  $T_{ra}$ , ambient,  $H_{aa}$  and  $T_{aa}$ , and supply air,  $H_{sa}$  and  $T_{sa}$ . The mixed air humidity, therefore has to be estimated from the ambient and return measurements, as depicted in Figure 2. Water temperature entering,  $T_{wi}$  the coil was available. Finally, the primary circuit water mass flow rate,  $\dot{m}_{w,max}$  ( $\text{kgs}^{-1}$ ) was measured. The mass flow through the coil is not typically measured in HVAC systems. In this instance, the part load mass flow rate needed to be estimated using a valve/actuator model that has the cooling coil control signal,  $u_{cc}$ , as an input.

Due to system constraints, the cooling coil was served by two chilled water sources during the tests periods. In winter a local 35 kW two-stage, reciprocating, air-cooled chiller, was used. In the spring and summer test periods, chilled water was supplied by a central plant serving the test facility and other buildings in the vicinity. The chilled water circuits local to the cooling coil were served by a fixed speed pump and the coil was controlled by varying the water mass flow rate via a three port mixing valve installed in a diverting application. The winter test conditions were selected to generate conditions that required no load on the cooling coil. A pre-heat coil in the outside air duct was used to adjust the ambient air temperature to achieve the required conditions.

## Results

In order to evaluate the implications of uncertainty on condition monitoring, two operational modes are required: ‘fault free’ and ‘fault present’. Under ‘fault present’ operation the control system parameters are the same as for normal operation. The system has a monotonic fault condition imposed on it. The system seeks to maintain the desired space conditions despite the fault and will achieve this unless the fault is so severe as to cause the system to saturate. Two fault conditions have been selected on the basis that the conditions affect opposite ends of the operating range and they can both be implemented in the system in a repeatable manner. The fault conditions are:

Table 3: Approximate Magnitudes of the Fault Levels Implemented as a Percentage of Maximum Water Mass Flow ( $1.6\text{kgs}^{-1}$ ), in Ascending Order of Severity.

Fault Level	Leakage (%)	Under Capacity (%)
No Fault	0.0	100
1	2.5	70
2	4.5	40
3	7.0	25

- control valve leakage;
- and coil under capacity.

The leakage fault is implemented by incorporating an additional leg with a flow control valve that, if open, allows water to by-pass the control port of the valve. Thus, there can be water flow through the coil when the control valve is closed. This fault is most apparent when the valve is closed and hence should be most visible in winter, less so during spring and will be unlikely to be observed during the summer period. Three magnitudes levels of leakage implemented. The coil capacity fault also introduced in three stages. This was implemented by increasing the effective mixing valve control port resistance by the installation of an additional valve. The increased resistance reduced the flow of chilled water through the coil. Table 3 gives the approximate magnitude of each fault level relative to the maximum water mass flow rate (taken as  $1.6\text{kgs}^{-1}$ ), for both faults.

The leakage fault was implemented in spring and winter and the under capacity fault in spring and summer and all three seasons had fault free days. No fault detection is possible if either  $V_{sa} = 0.0\text{m}^3\text{s}^{-1}$  or  $\dot{m}_w = 0.0\text{kgs}^{-1}$  and the fault indicators used are set to zero in these cases. The fault free and fault present data for each season is shown in Figures 4 to 10.

The condition monitoring scheme yielded no false alarms (Figures 4, 6 and 8). Each fault implemented over the three trial periods was detected. Winter provided the most decisive detection of the presence of valve leakage (Figure 7). The summer operating conditions clearly identified the presence of under capacity (Figure 5). The spring conditions (Figures 10 and 9) demonstrated that detection was possible, but the evidence is likely to be more sparse, unless the fault magnitude is increased. Concluding comments are:

- in absolute terms, leakage is easier to detect than under capacity, due to the nature of the non-linear, high gain, heat-exchanger characteristics at the low end of operation;
- the valve needs to be closed if leakage is to be detected, but the detection of under capacity does not need to be at the saturation point;
- the uncertainty in the system under high load conditions, would require faults to affect the total load by  $> 5.0\text{kW}$  and  $>3.0\text{kW}$  for under capacity and leakage respectively (14% and 9% of the rated coil duty);
- on typical summer days, detection of a leakage in the valve is not likely since normally  $U_{cc} \neq 0.0$ ;

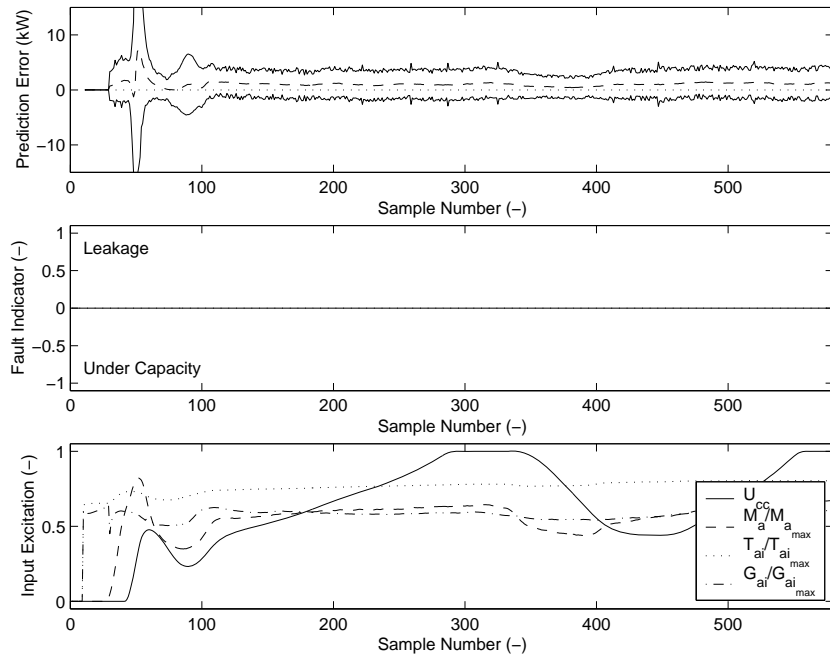

Figure 4: Summer Normal Operation (No Fault).

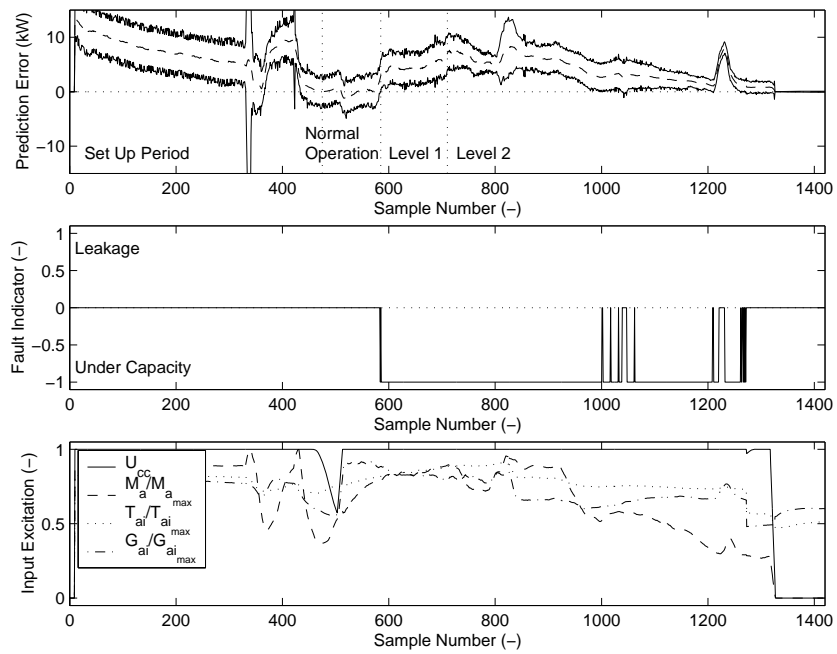

Figure 5: Summer Under Capacity (Fault Levels 1 and 2).

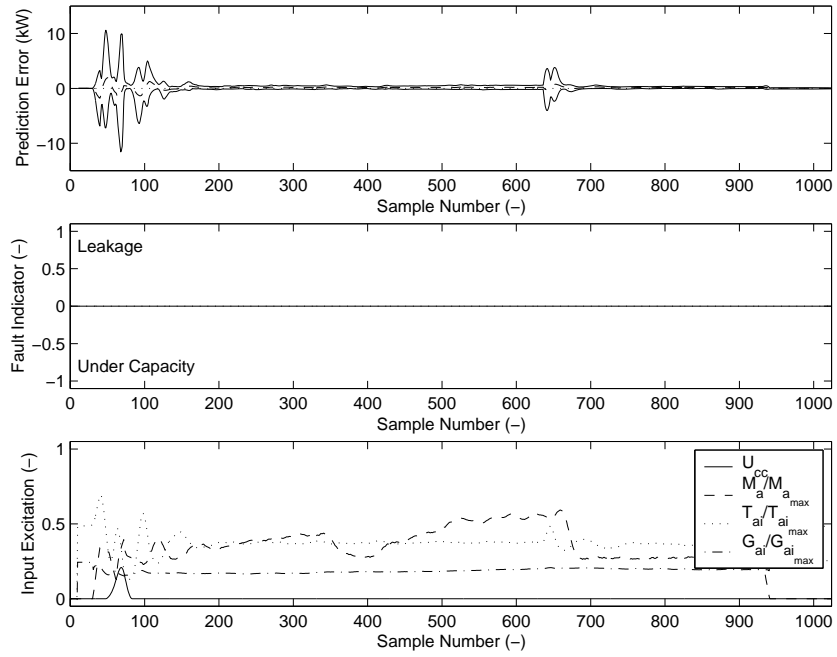

Figure 6: Winter Normal Operation (No Fault).

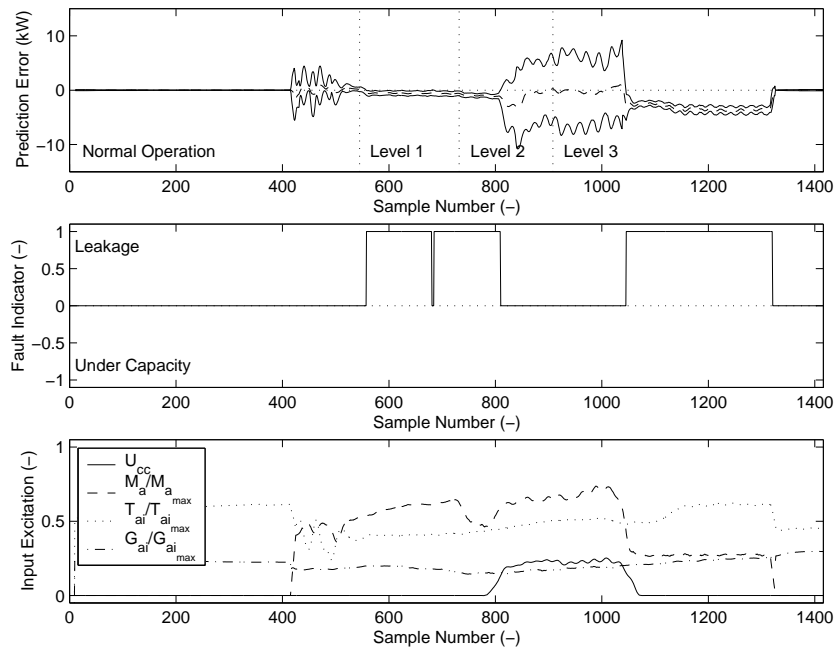

Figure 7: Winter Leakage (Fault Levels 1, 2 and 3).

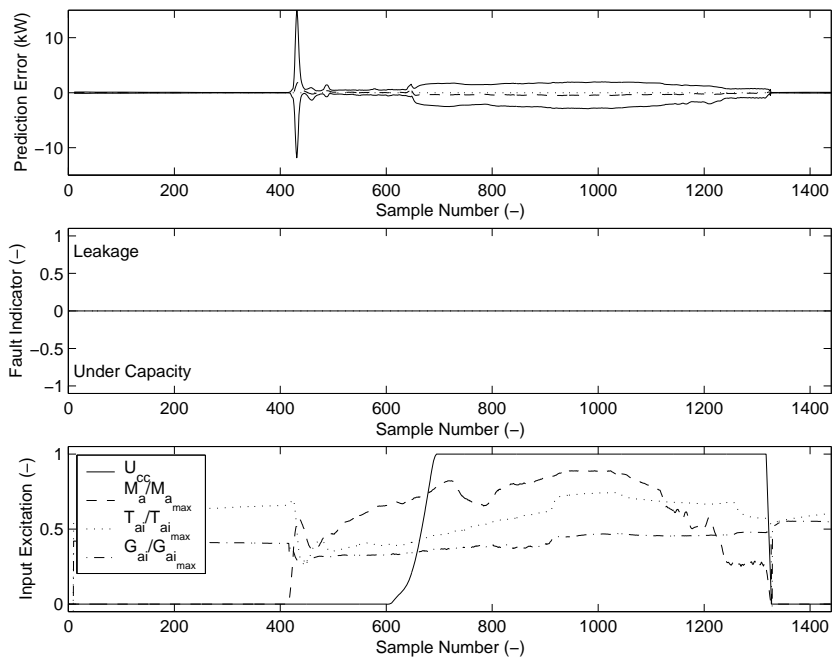

Figure 8: Spring Normal Operation (No Fault).

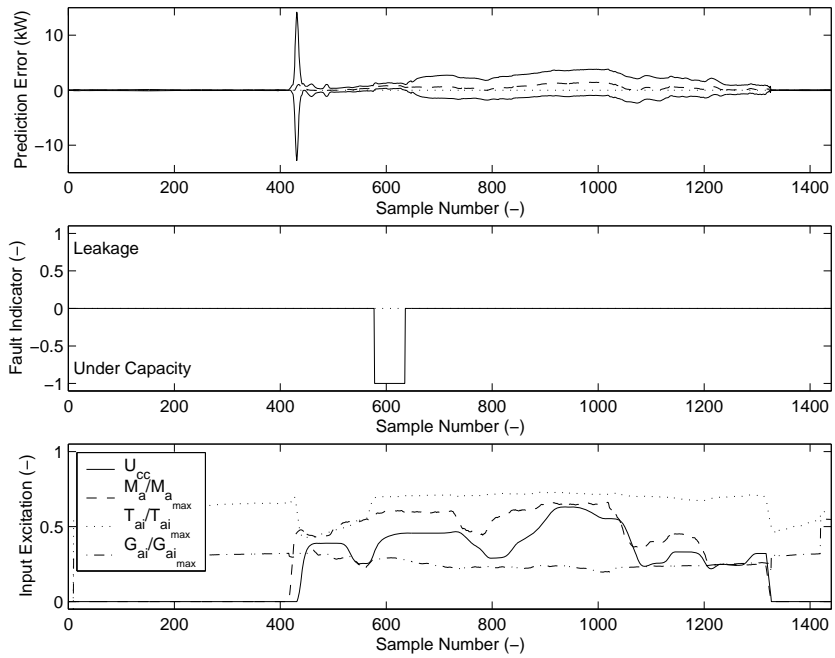

Figure 9: Spring Under Capacity (Fault Level 3).

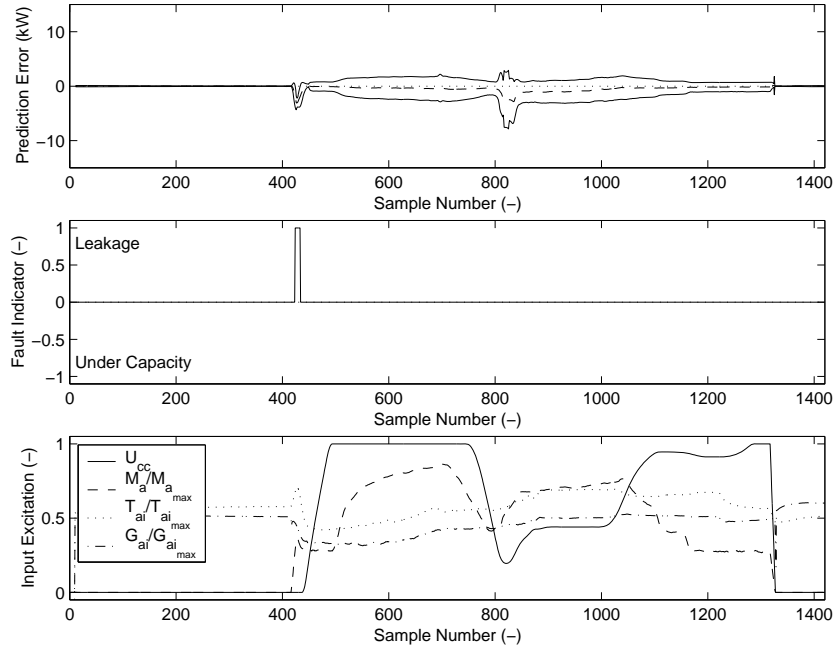

Figure 10: Spring Leakage (Fault Level 3).

- the under capacity fault in the summer could be detected at the smallest level implemented (a 30% reduction in maximum flow rate  $\approx 0.5\text{kgs}^{-1}$ );
- the smallest level of leakage could be detected (2.5% of the maximum water flow rate,  $\approx 0.04\text{kgs}^{-1}$ ).

## Conclusions

The difficulty in selecting good alarm thresholds that balance robustness and sensitivity were identified as a principle issue in the successful application of condition monitoring techniques. This paper demonstrated that this balance can be met in a transparent and analytical manner, through the application of uncertainty analysis. The sources of uncertainty were discussed. A Condition Monitoring scheme that accounted for all these uncertainties was implemented on a typical HVAC cooling coil subsystem installed in a real building. It was demonstrated that the scheme generated no false alarms and was able to detect all faults implemented. Specific conclusions are:

- a transparent and analytical approach to establishing the balance between sensitivity and robustness is possible using uncertainty analysis;
- commonly used engineering methods and judgement can be employed to establish values of uncertainty, resulting in a straightforward configuration procedure;
- the test system was fairly typical of HVAC systems and consequently, Table 4 summarises reasonable estimates of generally applicable, *minimum* fault magnitudes, that can be detected in real systems;

Table 4: The Magnitudes of Faults that can be Detected in Each Season, in Terms of Total Heat Transfer and as a Percentage of Full load (35.0kW).

Season	Leakage (kW)	(%)	Under Capacity (kW)	(%)
Summer	>3.0	9	>5.0	14
Spring	>1.0	3	>2.5	7
Winter	>0.5	1	-	-

- by implication, uncertainty affects all aspects of system monitoring, modelling and control.

### Acknowledgements

The authors acknowledge the use of the test data generated under the ASHRAE funded research project 1020-RP.

### References

- (1998). *Sontay Product Catalogue, 1999*. Sontay, England.
- Buswell, R, A. (2001). *Uncertainty in the First Principles Model Based Conditioning Monitoring of HVAC Systems*. Loughborough University, UK. Ph.D. Thesis.
- Buswell, R, A., A. Wright, J, I. Salsbury, T, and P. Haves (2002, December). Non-linear recursive parameter estimation applied to fault detection and diagnosis in real buildings. In *Proceedings of System Simulation in Buildings '02*, Liège, Belgium.
- Carling, P. and P. Isaksson (1999). Temperature measurement accuracy in an air-handling unit mixing box. In *Proceedings of the third international symposium on heating, ventilation and air-conditioning*.
- Coleman, H. W. and W. G. Steele (1995, October). Engineering application of experimental uncertainty analysis. *American Institute of Aeronautics and Astronautics 33, No. 10*.
- Dexter, A. and J. Pakenen (2001). *Demonstrating Automated Fault Detection and Diagnosis in Real Buildings*, Volume VTT Symposium 217. VTT Building Technology, Espoo, Finland.
- Holmes, M. J. (1982, December). The simulation of heating and cooling coils for performance analysis. In *Proceedings of System Simulation in Buildings '82*, Liège, Belgium.
- Hyvärinen, J. (1997a). *IEA Annex 25 Final Report*. VTT, Espoo, Finland.
- Hyvärinen, J. (1997b). *IEA Annex 25 Final Report, Volume II - Real Time Simulation of HVAC Systems for Building Optimization, Fault Detection and Diagnosis, Technical Papers of IEA Annex 25*. VTT, Espoo, Finland.
- Johnson, A. B., C. J. Simonson, and R. W. Besant (1998). Uncertainty analysis in the testing of air-to-air heat/energy exchangers installed in buildings. *ASHRAE Transactions 104 Pt. 1B*.

- Kline, S. J. and F. A. McClintock (1953, Jan.). Describing uncertainties in single-sample experiments. *Mechanical Engineering* 75 No. 3.
- Norford, L. K., A. Wright, J. A. Buswell, R., and D. Luo (2000). *Final Report of ASHRAE Research Project 1020-RP: Demonstration of Fault Detection and Diagnosis in Real a Building*. Massachusetts Institute of Technology and Loughborough University.
- Norford, L. K., A. Wright, J. A. Buswell, R., D. Luo, J. Klaassen, C, and A. Suby (2002). Demonstration of fault detection and diagnosis methods for air-handling units (ashrae 1020-rp). *HVAC & R Research* 8, Number 1.
- Oughton, R. J. (1985). *Applications Manual: Automatic Controls*. CIBSE, London, England.
- T. M. Rossi, J. E. B. (1994). Reducing operating costs with optimal maintenance scheduling. Working paper, distributed at the 8th meeting of IEA Annex 25, Stuttgart, Germany.