



This item was submitted to Loughborough's Institutional Repository (<https://dspace.lboro.ac.uk/>) by the author and is made available under the following Creative Commons Licence conditions.

  
C O M M O N S D E E D

**Attribution-NonCommercial-NoDerivs 2.5**

**You are free:**

- to copy, distribute, display, and perform the work

**Under the following conditions:**

 **Attribution.** You must attribute the work in the manner specified by the author or licensor.

 **Noncommercial.** You may not use this work for commercial purposes.

 **No Derivative Works.** You may not alter, transform, or build upon this work.

- For any reuse or distribution, you must make clear to others the license terms of this work.
- Any of these conditions can be waived if you get permission from the copyright holder.

**Your fair use and other rights are in no way affected by the above.**

This is a human-readable summary of the [Legal Code \(the full license\)](#).

[Disclaimer](#) 

For the full text of this licence, please go to:  
<http://creativecommons.org/licenses/by-nc-nd/2.5/>

# Optimised Building Form for Environmental Sustainability



**Monjur Mourshed\***

Department of Built Environment, University of Central Lancashire, Preston, PR1 2HE, UK.

**Denis Kelliher, Marcus Keane**

Department of Civil and Environmental Engineering, National University of Ireland, Cork, Ireland.

## ABSTRACT

*Built environment professionals have the opportunity to contribute towards a significant reduction in GHG emissions using green design principles. The starting point of green design is the optimum building form that requires less energy to construct and to operate, provided that the other design goals are satisfied. Using the interoperability based Architectural Design Optimisation Tool (ArDOT) software environment, this research was aimed at the optimisation of form and orientation of an example building in two different climatic locations. The optimisation process was driven by the results from the building simulation software, integrated into ArDOT using Industry Foundation Classes (IFC). The objectives were to reduce annual demand for energy and to maximise daylight availability. The applicability of the framework has been investigated in the early stages of architectural design, where required parameters for building simulation are not fully known. A standards based mapping is used to compensate for the missing data and to enable the design team the access to detailed based simulation programs. The results from the research show the advantages of using mathematical optimisation techniques for environmental sustainability through a directed exploration of the solution space.*

## Keywords

*Building energy efficiency, building form, multidisciplinary decision making, mathematical optimisation.*

## INTRODUCTION

Buildings are one of the biggest emitters of Greenhouse Gases (GHG), accounting for about 45% of carbon emissions in the UK. Built environment professionals thus have the unique opportunity to contribute towards a significant reduction in GHG emissions using green design principles. The starting point of green design is the optimum building form that requires less energy to construct and operate, provided that the other design goals are satisfied. The search for an optimum form satisfying predefined design objectives is a complex decision making activity that involves multidisciplinary appraisal of building performance against set criteria. Collaborative and performance based design depends heavily on the ability of the concerned stakeholders to communicate with each other using unambiguous representations of the domain. The 'ambiguity' usually arises from the differing representations, subscribed to by various professional groups involved in the design and construction of buildings. To facilitate

---

\*Corresponding author. Email address: mmourshed@uclan.ac.uk  
Copyright © 2006 Global Built Environment Network. All rights reserved.

communication and collaboration, semantics based interoperable standards, such as Industry Foundation Classes (IFC)<sup>1</sup> (IAI 2005) and Standard for Exchange of Product model data (STEP)<sup>2</sup> (ISO 1994) have been developed. They offer significant advantages in removing barriers to effective collaboration and the integration of performance appraisal tools and processes. However, the success of interoperability based solutions for multidisciplinary performance appraisal relies on the applicability of the appraisal/simulation tools in different lifecycle stages of a building. Building simulation tools are developed mostly in research organisations and focus on ‘*modelling for simulation*’ than on the integration with the design process. “A large amount of input processing is required even to simulate a small subset of the domain. Complicated processes to accomplish tasks made their use limited to occasional validation of the proposed idea than to assist in the design development” (Mourshed *et al.* 2003a).

Decisions regarding building form and orientation are made during the early stages of design, which is characterised by loosely defined representation of the domains involved. The use of building simulation in the design process, on the other hand, requires specialist knowledge on simulation and a rich set of information which are not necessarily available at early stages. Standard based mapping of information; i.e. substituting simulation parameters with widely accepted standards can facilitate simulation assisted design exploration by compensating for the missing data. Examples of mapping for concurrent multi-domain performance evaluation can be found in (Mahdavi *et al.* 1997). This offers an alternative to simplified simulation tools and improves the accuracy of performance evaluation by allowing the design team members access to the detailed based simulation tools. Augenbroe and Hensen (2004) have elaborated on the advantages of detailed based simulation over the simplified ones for environmental design of buildings.

Exploration of the solution space; e.g. all the possible solutions for a particular design, is another important design task for enhanced sustainability. Simulation/appraisal of building performance can only help if the solution/design space is searched effectively. A large number of design variables for buildings makes this task difficult to accomplish. Parametric simulations do not provide the bigger picture as only a small subset of variables (typically  $n=2$ ) can be effectively analysed and visualised. For a directed exploration of the solution space, numerical optimisation methods can be applied to enhance simulation assisted design.

ArDOT (Architectural Design Optimisation Tool) (Mourshed *et al.* 2003b) is an integrated and interoperability based software environment that enables concurrent and multidisciplinary performance appraisals and decision making in architecture. For a directed search of the solution space, ArDOT uses mathematical optimisation techniques; i.e. gradient and non-gradient based methods. ArDOT enables the decision maker, in this case an architect, to understand the dynamic interplay of a large number of design variables.

This paper reports on the application of the ArDOT framework in optimisation of form and orientation of an example building in two different climatic locations (moist mid-latitude and arid). Kilkenny<sup>3</sup>, Ireland and Phoenix<sup>4</sup>, AZ have been chosen as the locations for the experiment using the Köppen climate classification modified by Trewartha (1968).

## **ARDOT: ARCHITECTURAL DESIGN OPTIMISATION TOOL**

ArDOT framework is designed as a flexible, reusable, scalable and distributed three-tier information system (Figure 1). Interoperability between the implemented and future toolsets is provided by the third layer called ‘process management’ that contains integration logic. The core layer is used for data representation where project data is stored and shared. Examples of three-tier system architecture based on IFCs can be found in (Faraj *et al.* 1999; Keane and Kelliher 2001; Owolabi *et al.* 2003; Yang 2003; Lam *et al.* 2004). Server-side process management tier contains SDAI (ISO 1998) interface to connect to IFC based product model

database(s). The topological logic resides in this layer which extracts necessary information from the database and serves the requests from client side applications, otherwise known as domain logic. To serve XML/HTTP requests, a web server is connected to the SDAI sub-layer via extensions. Web services can also be implemented via SOAP<sup>5</sup> interfaces to web server. User system interfaces or GUI can either be standalone or web applications.

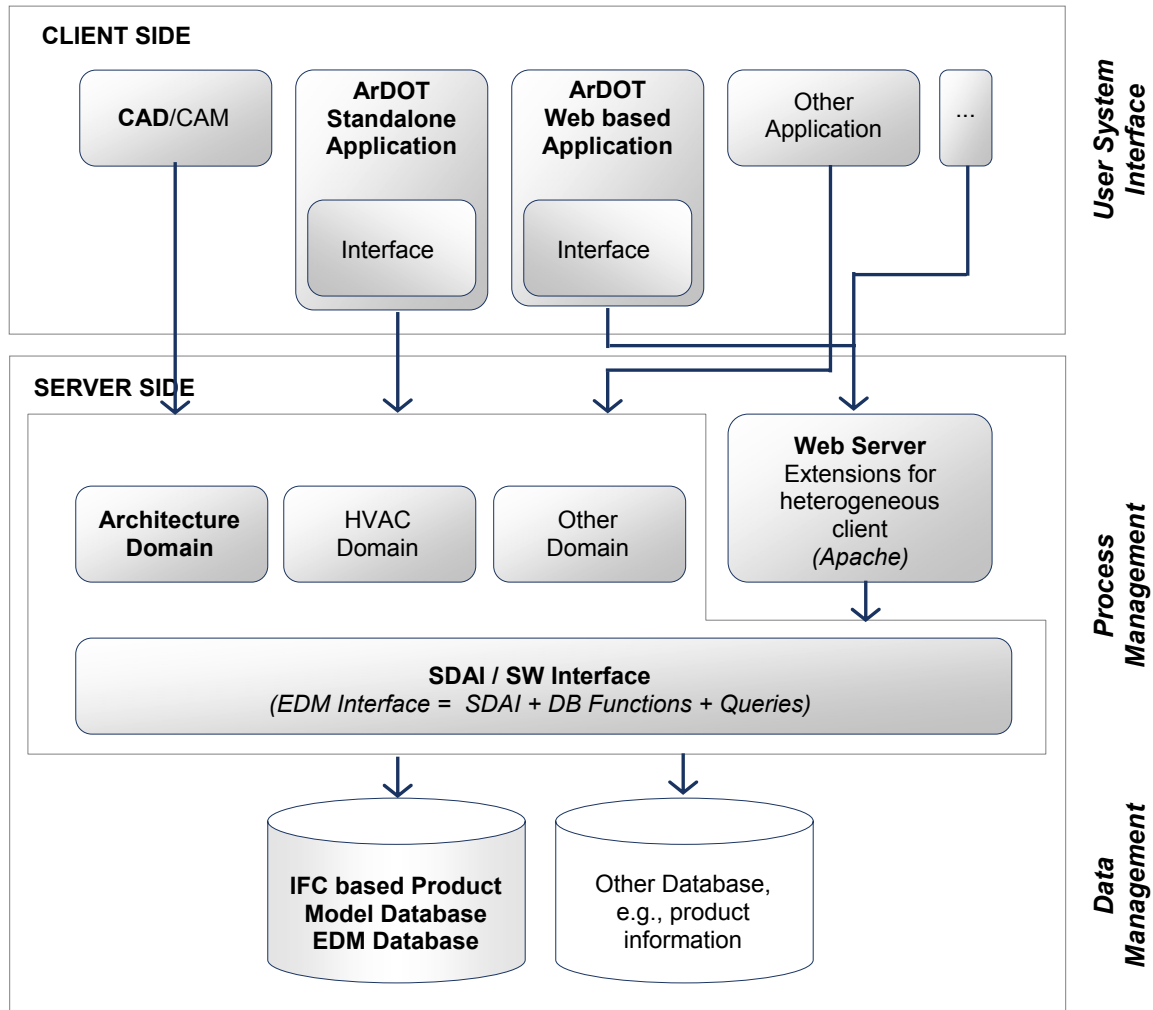

Figure 1: ArDOT framework.

Two variants of the user interface have been implemented in ArDOT: browser based thin client and Java based multi-platform application. Population of Product Model Database (PMD) usually starts with the initial sketches done by the architect in IFC compliant CAD system. IFC objects are extracted using SDAI access methods and mapped against the application logic, defined in an XML schema. ArDOT provides a framework for further manipulation of architectural form by combining building simulation and optimisation techniques for informed decision making. j3d<sup>6</sup>, a Java3D API provides 3D graphics rendering in real time for ArDOT. 3D visualisation module of ArDOT is shown in Figure 2 where building form can be viewed in either parallel or perspective mode. The UI also allows zooming, rotation and translation of views. Components of the Java based ArDOT including the implemented optimization algorithms are shown in Figure 3.

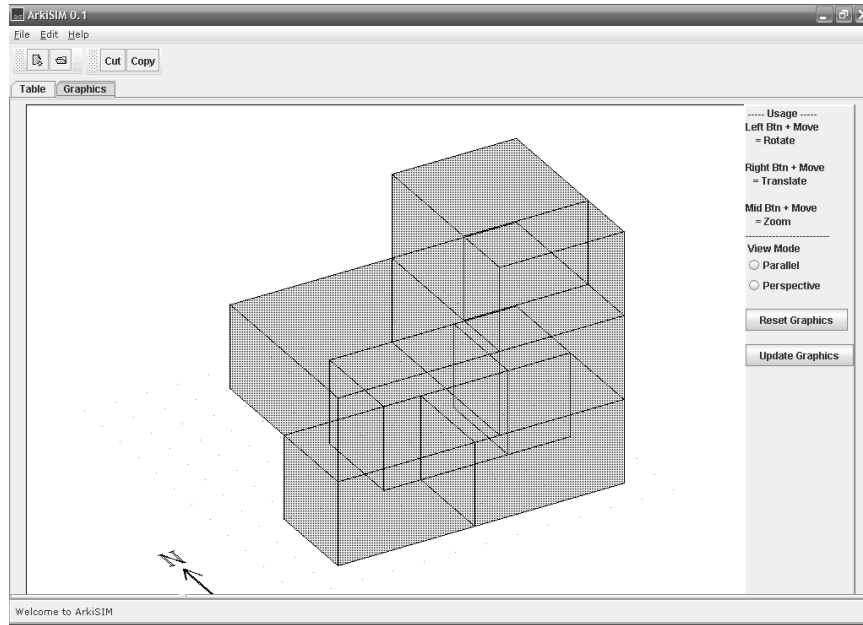

Figure 2: 3D visualisation in ArDOT.

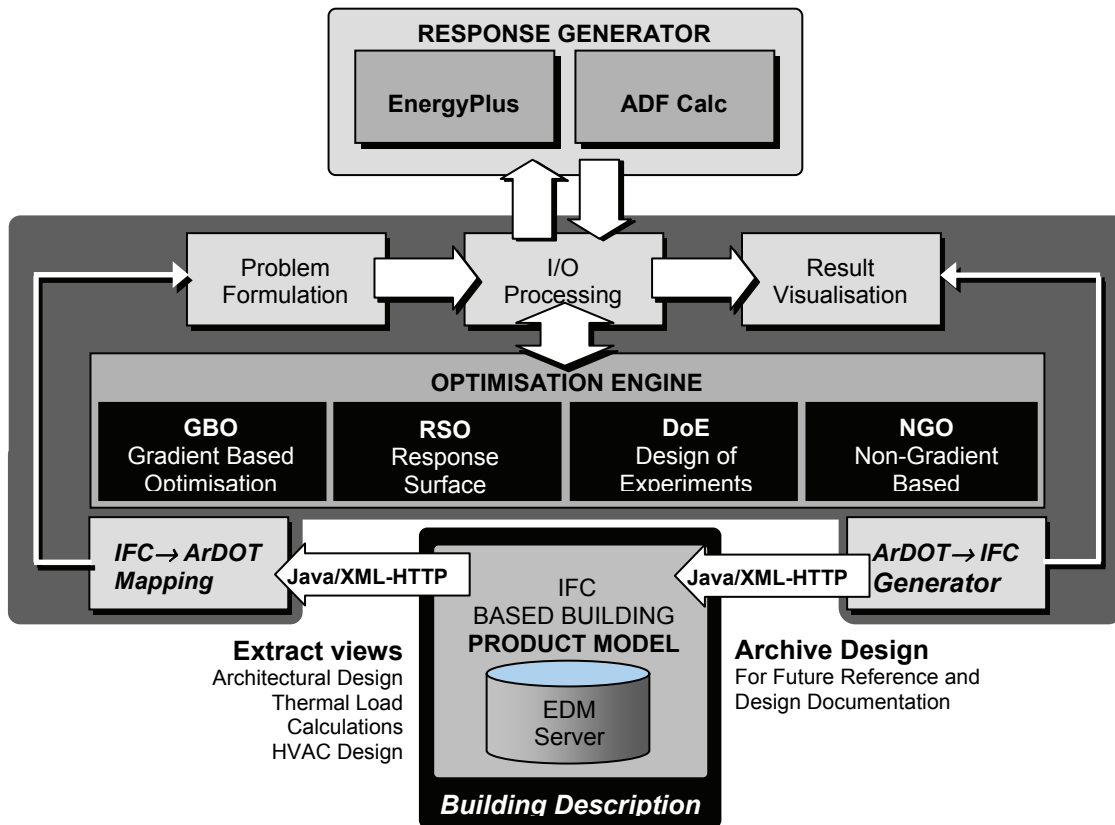

Figure 3: Components of the Java based ArDOT system, source (Mourshed et al. 2003b).

## PROBLEM FORMULATION

To test the applicability of the framework in multidisciplinary decision making, environmental design of buildings has been chosen as the domain of discourse. The decision for the selection of domain was governed by the availability of industry standard simulation tools which had undergone decades of development. Reviews of trends and advancements of building simulation can be found in (Hensen *et al.* 2002; Malkawi 2004). The experiment demonstrates vertical integration among applications from a single domain as well as provides mechanisms for cross-domain horizontal integration. EnergyPlus (Crawley *et al.* 2001) has been chosen as the simulation engine to model multi-domain environmental design problems. EnergyPlus is a versatile simulation engine capable of modelling loads and annual energy use for an entire building. The accuracy of EnergyPlus has been validated against other building energy programmes using the BESTEST method (Witte *et al.* 2001). To demonstrate the versatility of the framework in combining multiple response generators, a separate hard-coded module has been added to compute average daylight factor (DETR 2002) of the proposed designs. The tool to compute average daylight factor is hereafter called ADF Calc. *Daylight factor* can be a valuable design tool, particularly at the early design stages, as described in (Loe and Mansfield 1998; DETR 2002) through the use of a simplified design method developed by the Building Research Establishment (BRE) which is implemented in ADF Calc. The method relates an Average Daylight Factor,  $DF_{avg}$ , to the glazed area within the zone. This factor is defined as the ratio of a room's average internal illuminance at the working plane to that of the external global horizontal illuminance, expressed as a percentage of standard overcast sky conditions:

$$DF_{avg} = \frac{\sum (W \tau \theta M)}{A(1 - R^2)} \quad (1)$$

where:  $DF_{avg}$  is the Average Daylight Factor,  $W$  is the area of each window ( $m^2$ ),  $\tau$  is the transmittance of each glazing,  $\theta$  is the vertical angle of visible sky, measured from the centre of the window opening in the plane of the inside window wall,  $M$  is the maintenance factor based on angle of glazing and cleanliness,  $A$  is the total internal surface area of the space ( $m^2$ ), and  $R$  is the area weighted average reflectance of all surfaces making up  $A$ .

### Multi-criteria decision making

This experiment has been designed with two interdependent objective functions. Annual cumulative energy consumption and a predefined ADF have been selected as objectives for the optimisation problem. An increase in the ADF results in greater availability of daylight; sometimes offering significant energy savings by offsetting a portion of the electric lighting load. This may also increase cooling or heating loads because of heat gain or loss through increased glazing in façades, respectively. Reduction in internal gains can result in lower cooling demands in hot climates but higher heating demands in cold climates which may be compensated by solar gains during daytime. In addition to energy savings, daylighting generally improves occupant satisfaction and comfort (LANL 2002), which may be one of the design objectives provided that the cumulative energy consumption remains at an acceptable level. A one-zone, single-storied commercial building with an aggregate floor area of 500  $m^2$ . has been tested here. There are four windows on four cardinal sides of the building expressed as a fraction of the cardinal wall areas. Other than the fraction glazing on the four sides, building azimuth and building aspect ratio (width/length) are allowed to change. Graphical representation of the problem is shown in Figure 4. Values of design variables for starting points are given in Table 1. Values for objective ADF varies from 2% to 8% in 7 different runs. Simulation is performed based on two separate schedules: regular and extended office hours.

The reason behind running the building with two schedules is to see the impact of the absence of daylight during winter nights on building form and orientation. Parameters for implemented optimisation algorithm are given in Table 2.

Table 1: Values of design variables for starting points

Variables	Starting point value
Building azimuth (deg)	0.0
Building aspect ratio	0.15
North glazing fraction	0.5
South glazing fraction	0.5
East glazing fraction	0.5
West glazing fraction	0.5

Table 2: Parameters for implemented optimisation algorithm

Design control information			
Optimisation method	SQP (Sequential Quadratic Programming)		
Objective	Minimise		
Constraint tolerance	-0.03		
Violated constraint tolerance	0.003		
Gradients calculated by	First forward difference		
Relative finite difference step	0.001		
Minimum finite difference step	0.0001		
Optimiser parameters			
Relative hard convergence criteria	0.001		
Consecutive iteration for convergence	2		
Maximum number of iteration	100		
Design response information			
	Objective	Constraint	
Total Energy Consumption	Yes	No	
Daylight Factor	No	Yes	
Design constraints information			
	Bound	Limit	Scale Factor
Daylight Factor	Lower	Variable	1.0
Design objectives information			
	Worst value	Weight factor	Target
Total Energy Consumption	Undefined	1.0	Minimise

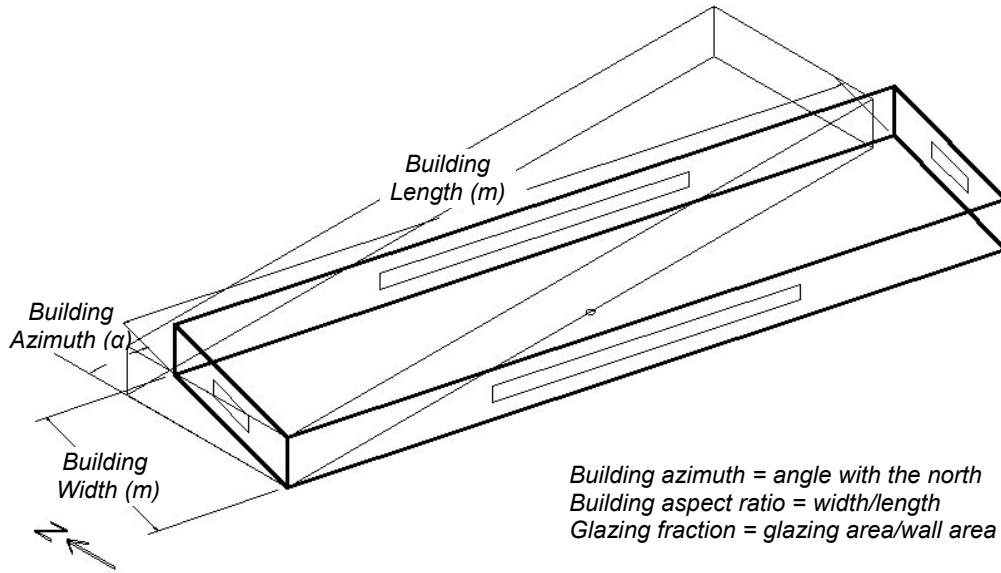

Figure 4: Graphical description of the problem under study.

## DISCUSSION OF RESULTS

Results for the building in Kilkenny, operating in regular schedule, are shown in Figure 5 (interpreted variables). Values of objective function (Total Energy Consumption) increases with the corresponding increase in the constraint value (Average Daylight Factor). The results also show relatively benign characteristics of Kilkenny climate. Relatively larger value of south glazing fraction and corresponding area of glazing reinforces conventional wisdom of bioclimatic design in Marine climates such as Kilkenny. The dominance of south glazing over other cardinal sides is visible from the resultant graphs.

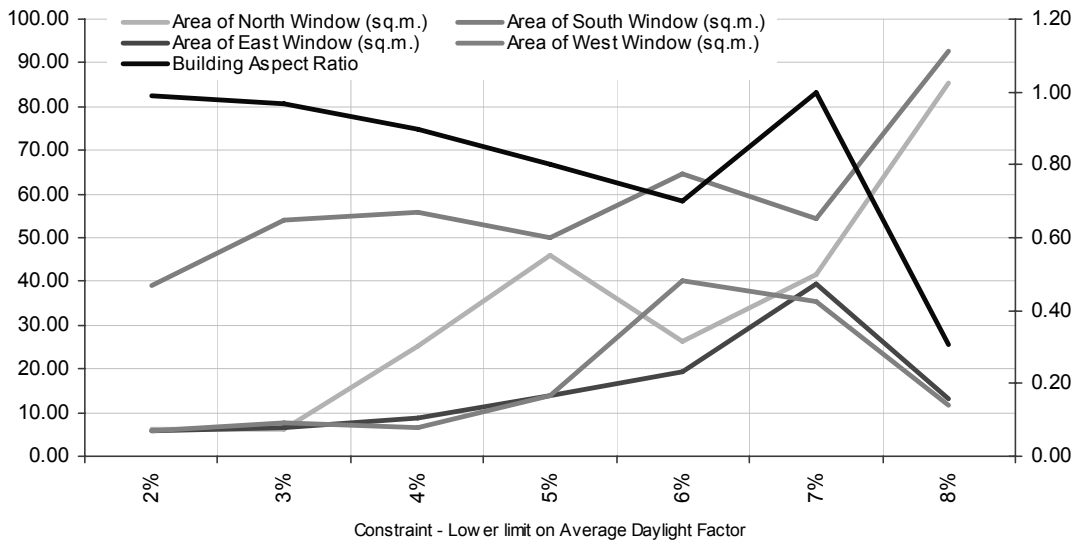

Figure 5: Interpreted design variables for Kilkenny, regular occupancy schedule.



Results for the study in Kilkenny with extended occupancy schedule in Figure 6 show pronounced difference than that of regular occupancy in Figure 5. Glazing on east and west sides are lower than that of south sides and continuous except for the ADF value of 7%. Pareto curves for Kilkenny with regular and extended occupancy schedules are shown in Figure 7a and 7b respectively.

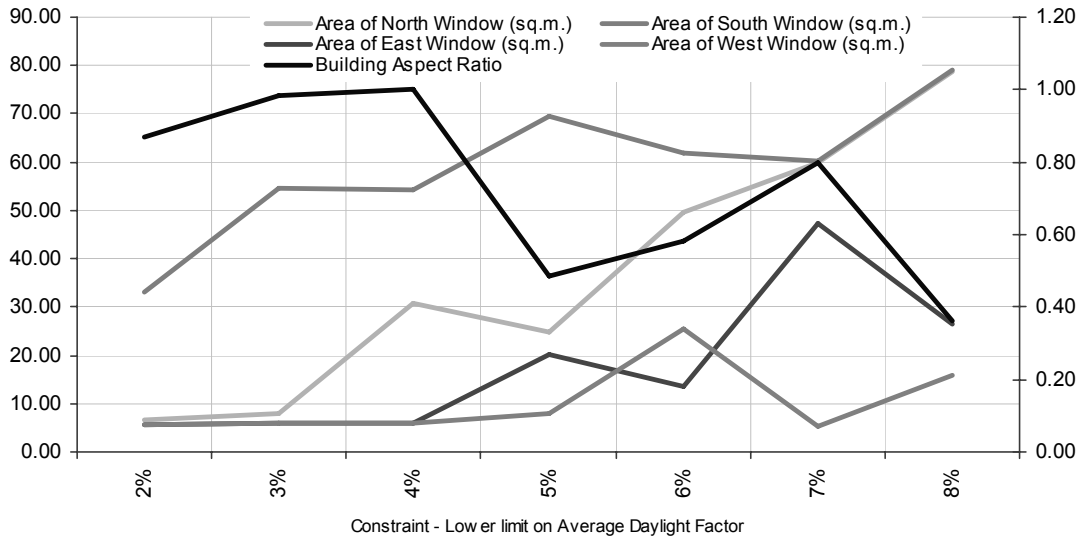

Figure 6: Interpreted design variables for Kilkenny, extended occupancy schedule.

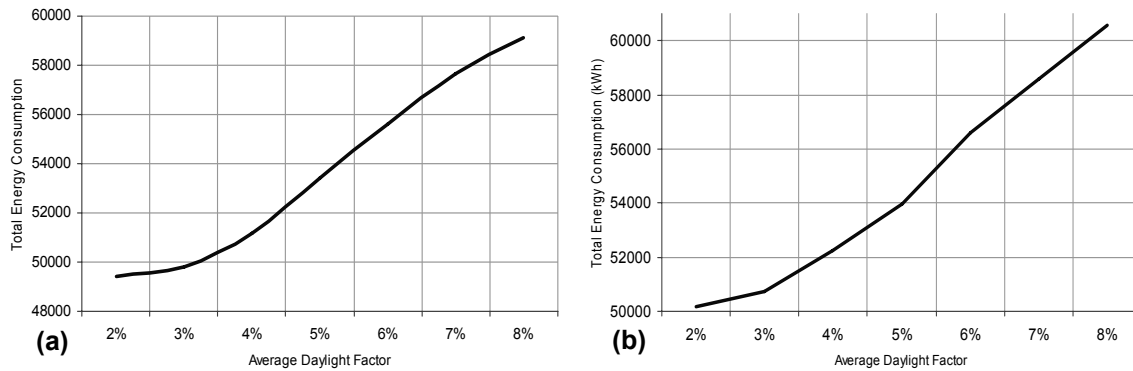

Figure 7: Pareto curves for Kilkenny: (a) regular and (b) extended occupancy schedule.

Results for Phoenix with regular occupancy schedule show a tendency towards maximisation of north glazing as the most feasible strategy for increasing glazing percentage. The reduction of solar heat gain seems to be the most efficient of bioclimatic strategies for Phoenix which is reflected in interpreted design variables in Figure 8. An increase in glazing area in the east and west is the last resort. Climatic parameters in Phoenix are more pronounced, hence the gradual increase in the values of design variables.

The drop in building aspect ratio for ADF values of 2% and 8% is more pronounced for buildings with extended schedule in Phoenix (Figure 9) mainly due to the night-time climate parameters affecting the form. Building aspect ratio of 0.23 at ADF 8% is a sharp decrease from initial 0.98 at ADF 2% which can be said to be resulted from the need to dissipate heat during the extended period. Increased surface will allow the building to cool down quicker than a more compact form. North glazing dominates the composition of the building envelope

followed by south glazing. Pareto curves for Phoenix with regular and extended schedule are shown in Figure 10a and 10b respectively.

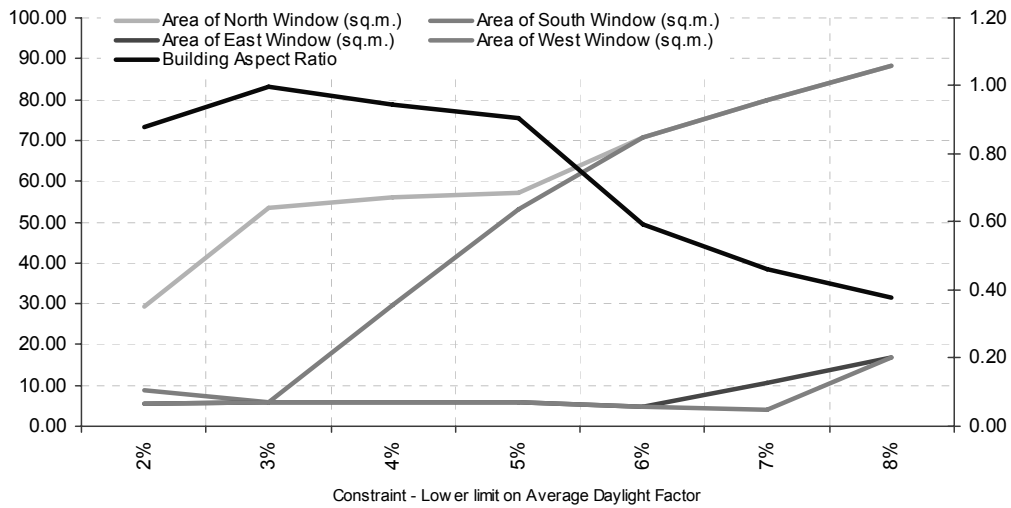

Figure 8: Interpreted design variables for Phoenix, regular occupancy schedule.

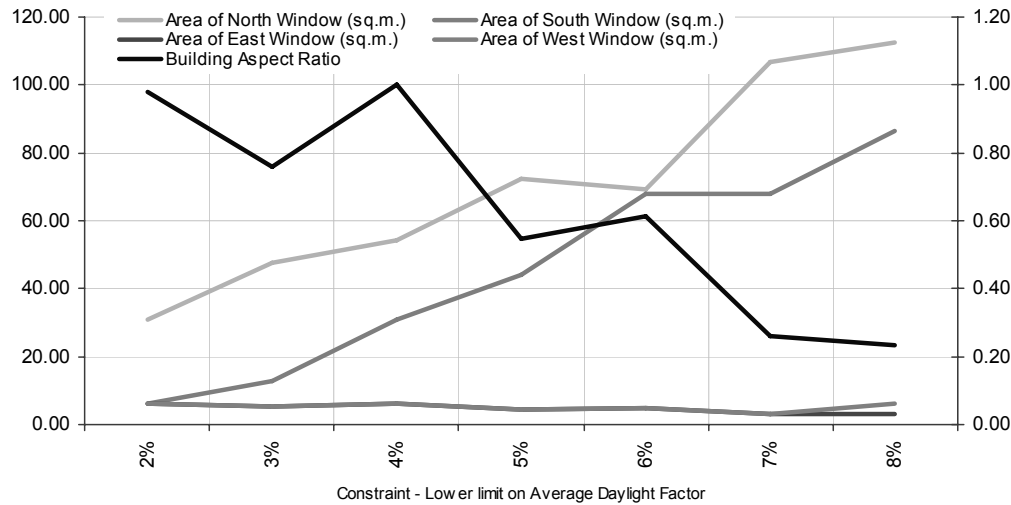

Figure 9: Interpreted design variables for Phoenix, extended occupancy schedule.

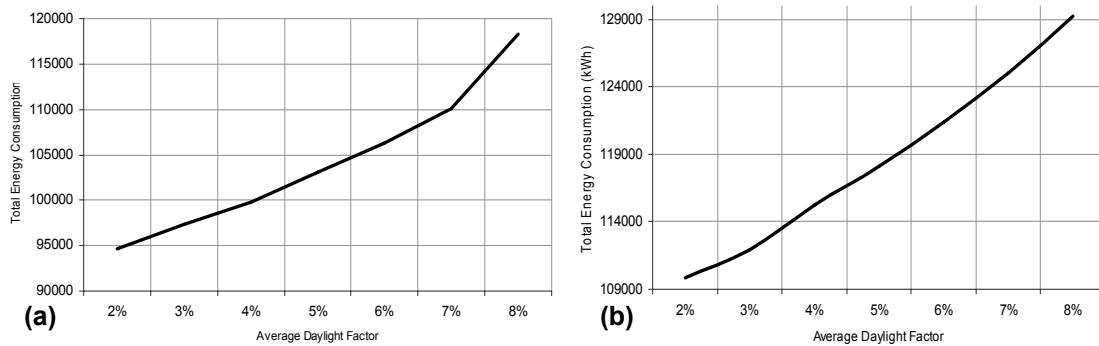

Figure 10: Pareto curves for Phoenix: (a) regular and (b) extended occupancy schedule.

## CONCLUSIONS

The study on multi criteria optimisation of environmental design of buildings shows the effectiveness of the application of mathematical optimisation in early stages of design. Unlike computationally expensive non gradient based methods used by Wetter and Wright (2003), gradient based methods such as SQP (Sequential Quadratic Programming), as tested in this study are efficient in converging to optimum. Multi-criteria optimisation of the study problem in different occupancy patterns conforms to the conventional wisdom in environmental design of buildings in respective climates. Application of Pareto optimality in multi-criteria optimisation shows how designers can perform informed decision making during design development.

The implementation of the integrated framework ArDOT, demonstrates the fact that integration and interoperability can be achieved during early stages of design. Interpolation of architectural standards for use as defaults during the translation between IFC and simulation input files show that the detailed building simulation capabilities can be brought to architectural designers at early stages of design; as opposed to the suggestions made by many: either (a) the use of simplified simulation programmes (Augenbroe 2002) or (b) incorporating simulators during early design exploration (McElroy and Clark 1999).

## REFERENCES

- Ahmad, N. and Wyckoff, A. (2003). *Carbon dioxide emissions embodied in international trade of goods*. DSTI/DOC(2003)15. OECD Publications.
- Augenbroe, G. (2002). Trends in building simulation. *Building and Environment*, 37(8-9), 891-902.
- Augenbroe, G. and Hensen, J. (2004). Simulation for better building design. *Building and Environment*, 39(8), 875-877.
- Crawley, D.B., Lawrie, L.K., Winkelmann, F.C., Buhl, W.F., Huang, Y.J., Pedersen, C.O., Strand, R.K., Liesen, R.J., Fisher, D.E., Witte, M.J. and Glazer, J. (2001). EnergyPlus: creating a new-generation building energy simulation program. *Energy and Buildings*, 33(4), 319-331.
- DETR (2002). *Desktop Guide to Daylighting - for Architects*. 245. Department of Environment, Transport and Regions, United Kingdom.
- Faraj, I., Alshawi, M., Aouad, G., Child, T. and Underwood, J. (1999). Distributed Object Environment: Using International Standards for Data Exchange in the Construction Industry. *Computer-Aided Civil and Infrastructure Engineering*, 14(6), 395-405.
- Hensen, J.L.M., Lamberts, R. and Negrao, C.O.R. (2002). A view of energy and building performance simulation at the start of the third millennium. *Energy and Buildings*, 34(9), 853-855.
- IAI (2005). *IAI international: mission, vision and goal*. [Online]. Available from: <[http://cig.bre.co.uk/iai\\_uk/iai/page3.htm](http://cig.bre.co.uk/iai_uk/iai/page3.htm)>
- ISO (1994). *Industrial automation systems and integration - Product data representation and exchange - Part 1: Description methods: Overview and fundamental principles*. ISO 10303-1:1994. Geneva: ISO.
- ISO (1998). *Industrial automation systems and integration - Product data representation and exchange - Part 22: Implementation methods: Standard data access interface*. ISO 10303-22:1998. Geneva, Switzerland: ISO.
- Keane, M. and Kelliher, D. (2001). Green building design management. *International Journal of Architectural Management, Practice and Research*, 16, 263-271.

- Lam, K.P., Wong, N.H., Mahdavi, A., Chan, K.K., Kang, Z. and Gupta, S. (2004). SEMPER-II: an internet-based multi-domain building performance simulation environment for early design support. *Automation in Construction*, 13(5), 651-663.
- LANL (2002). *LANL Sustainable Design Guide*. Los Alamos: Los Alamos National Laboratory.
- Loe, D. and Mansfield, K.P. (1998). *Daylighting Design in Architecture: Making the Most of a Natural Resource*. Garston, Watford: Building Research Establishment.
- Mahdavi, A., Mathew, P. and Wong, N.H. (1997). A homology-based mapping approach to concurrent multi-domain performance evaluation. In: *The second conference on computer aided architectural design research in Asia: CAADRIA*, Hsinchu, Taiwan, 17-19 April 1997, 237-246.
- Malkawi, A.M. (2004). Developments in environmental performance simulation. *Automation in Construction*, 13(4), 437-445.
- McElroy, L.B. and Clark, J.A. (1999). Embedding simulation within energy sector businesses. In: *BS '99: Sixth International IBPSA Conference*, Kyoto, Japan, 1197-1202.
- Mourshed, M.M., Kelliher, D. and Keane, M. (2003a). Integrating Simulation in Design. *IBPSA News*, 13(1), 21-26.
- Mourshed, M.M., Kelliher, D. and Keane, M. (2003b). A tool to optimise environmental design of buildings. In: *BS2003: Eighth International IBPSA Conference*, Eindhoven, Netherlands, 919-926.
- Owolabi, A., Anumba, C.J. and El-Hamalawi, A. (2003). Architecture for implementing IFC-based online construction product libraries. *Electronic Journal of Information Technology in Construction*, 8, 201-218.
- Trewartha, G.T. (1968). *An introduction to climate*. New York: McGraw-Hill.
- Wetter, M. and Wright, J. (2003). Comparison of a generalized pattern search and a genetic algorithm optimization method. In: *BS2003: Eighth International IBPSA Conference*, Eindhoven, Netherlands, 1401-1408.
- Witte, M.J., Henninger, R.H. and Glazer, J. (2001). Testing and Validation of a New Building Energy Simulation Program. In: *BS2001: Seventh International IBPSA Conference*, Rio de Janeiro, Brazil, 353-360.
- Yang, Q.Z. (2003). IFC-compliant design information modelling and sharing. *Electronic Journal of Information Technology in Construction*, 8, 1-14.

## NOTES

<sup>1</sup> IFCs are developed by the International Alliance for Interoperability (IAI). Website: <http://www.iai-international.org/>

<sup>2</sup> STEP is an international standard for the computer-interpretable representation and exchange of industrial product data. It has been developed and maintained by the ISO/TC-184-SC4 committee of the International Organisation for Standardisation (ISO). Website: <http://www.tc184-sc4.org/>

<sup>3</sup> Kilkenny, Ireland falls under group C: moist subtropical mid-latitude climates of type *Cfb*: *marine* in Köppen climate classification. The climate is characterized by low annual temperature in high latitude region, winds from the oceans moderate the climate and summers are quite cool. Places are usually humid with mild winters; average temperature of the coldest month ranges between -3°C to 18°C.

<sup>4</sup> Phoenix, AZ is classified as part of type *BWh: arid climate* in Köppen climate classification and characterised by deficient and irregular precipitation. Climate is hot and dry with a mean annual temperature of above 18°C; maximum daytime temperature during the summer can reach above 50°C.

<sup>5</sup> Simple Object Access Protocol is a w3 standard. <http://www.w3.org/TR/soap/>

<sup>6</sup> j3D is a Java 3D api. <http://java3d.j3d.org/>