

Drivers' field of view from large vehicles

Phase 2: Report

Undertaken on behalf of

The Department of Environment,
Transport and the Regions (DETR)

Prepared by

Dean Southall
Richard Tait
Tony Walsh

June 1998

Check

CONTENTS

Executive Summary	1
1. Introduction.....	2
2. Accident data	3
2.1 Truck accidents	3
2.2 Bus and coach accidents	5
3. Surveys of operators, manufacturers and drivers	6
3.1 Method.....	6
3.2 Sample.....	6
3.3 Truck results	7
3.3.1 Problems identified	7
3.3.2 Truck types	8
3.3.3 Truck vision solutions.....	9
3.4 Bus and coach results.....	9
3.4.1 Problems identified	9
3.4.2 Bus and coach types.....	10
3.4.3 Bus and coach vision solutions	11
3.5 Conclusions.....	11
4. Vehicle swept paths	14
5. Field of view requirement.....	15
6. Assessment of fields of view - Regulations and Directives	19
6.1 Regulations and Directives	19
6.1.1 Direct field of view	19
6.1.2 Current direct field of view regulations (M ₁ vehicles only)	20
6.1.3 Problems with current direct field of view Regulations	22
6.2. Current rear-view mirror Regulations.....	24
6.2.1 Method of determining driver's eye points.....	24

6.2.2 Mirror dimensions.....	27
6.2.3 Mirror optical characteristics	29
6.2.4 Minimum number of compulsory rear-view mirrors	29
6.2.5 Mirror positioning.....	31
6.2.6 Problems with current rear-view mirror Regulations	31
7. Assessment of existing vehicle design	34
7.1 Selection of assessment vehicles	34
7.1.1 Trucks	34
7.1.2 Buses & Coaches	35
7.2 Measuring and modelling of selected vehicles	36
7.3 Modelling of road environments for vehicle manoeuvres	36
7.4 Size and position of field of view 'targets'	38
Appendix 1	44
Table A: Analysis of bus drivers vision environment	44
Table B: Analysis of coach drivers vision environment.....	46
Table C: Analysis of truck drivers vision environment.....	48

Executive Summary

The overall objective of this phase of the study has been to identify problems with drivers' field of view from current large vehicles.

A large survey of drivers, operators and manufacturers was conducted which identified a number of issues pertaining to drivers' field of view, vehicle design and road environment. On the basis of this information, as well as a continuing review of accident data and analysis of vehicle swept path plots, it has been possible to develop a first stage field of view requirement.

The field of view requirement defines areas around a vehicle which the driver should be able to see or otherwise detect objects. At this stage the field of view requirement does not stipulate whether this should be by direct or indirect means. It is an aim of the Phase 3 report to make recommendations for the most appropriate means of achieving the requirement.

The development of the field of view requirement has provided the necessary criteria by which current vehicle designs and the adequacy of current Regulations and Directives are being assessed.

The assessment of existing Regulations and Directives has already identified inadequacies in their application to large vehicles which points to specific areas for new or amended regulations.

The short list of vehicles which will be used to quantify the effectiveness of current vehicle designs has been made. These vehicles have been precisely measured to produce the dimensional data necessary to carry out the Man-Model CAD assessment. The vehicles have been successfully modelled and the field of view assessment is in progress. The development of solutions and methods to improve drivers' field of view from large vehicles will be undertaken in parallel with the field of view assessment and the findings will be reported separately.

1. Introduction

The objective of this phase of the study is to make a detailed analysis of drivers' field of view from trucks, buses and coaches. The findings of this phase will then be used as the basis for developing recommendations for any necessary improvements to drivers' field of view.

The drivers' field of view analysis has been based on a number of tasks:-

- a continuing review of accident information;
- surveys of drivers, operators and manufacturers of large vehicles;
- a review of current Regulations and Directives in view of accident data and driver, operator and manufacturer experiences;
- the development of assessment criteria for assessing field of view from large vehicles;
- the measurement of drivers' field of view from large vehicles.

(This task is still underway and upon completion a separate report will be submitted describing the findings and implications).

2. Accident data

Direct notifications of accidents involving trucks, buses and coaches continue to be received via ICE's contacts with local police forces. At the time of writing we have reports of 78 truck and 64 bus/coach accidents. The information available from these reports is limited and deciding whether the accident was likely to have involved a driver vision element is somewhat subjective unless specific reference was made in the report to, for example, 'blind spots'.

2.1 Truck accidents

On subjective criteria, 30 of the 78 truck accidents notified to ICE may have a driver vision element. Of these, 2 resulted in fatalities (to other road users), 15 were serious, 7 were slight and 6 involved no personal injury.

The data does not implicate any particular types or model of vehicle.

Explicit reference to blind spots was made in six cases, although three of these were foreign trucks with left hand drive.

The manoeuvres being undertaken at the time of the accidents were:-

Reversing	9 (1 fatal, 4 serious, 4 slight)
Turning left	4
Turning right	0
Straight on	5
Changing lane	6
At a roundabout	2
At traffic lights	2
Not known	2

The relatively high proportion of reversing accidents had not been identified previously and attempts to confirm this finding via other sources will be made throughout the course of the remainder of this study. However, it suggests that the study should consider options to address reversing accidents. It may prove

useful to find out if any studies have been conducted on the effectiveness of devices such as reversing alarms, rear CCTV or auto reverse braking.

The second source of information on trucks was a study, undertaken by the Metropolitan Police, of accidents involving HGV's and vulnerable road users at road junctions. The study includes data for the years 1988 to 1994 but no information directly relating to visibility is given in the study. However, it indicates the direction of movement of those involved in the accident and so identifies the more hazardous manoeuvres. The findings are summarised in Table 1 below:-

Table 1: Number of accidents at road junctions between HGVs and vulnerable road users indicating direction of travel at time of incident

Motorcycle vs HGV - 20 cases

Motorcycle manoeuvre	Number	HGV manoeuvre	Number
Turning left	4	Turning left	4
Straight on	11	Straight on	7
Turning right	1	Turning right	4
Ahead opposite	4	Ahead opposite	5

Pedestrians vs HGVs - 91 cases

Pedestrian manoeuvre	Number	HGV manoeuvre	Number
From near-side	66	Turning left	12
Straight on	1	Straight on	68
From off side	24	Turning right	11
		Reversing	1

Pedal cycles vs HGVs- 54 cases

Pedal cycle manoeuvre	Number	HGV manoeuvre	Number
Turning left	7	Turning left	35
Straight on	45	Straight on	15
Turning right	1	Turning right	3
Ahead opposite	1	Ahead opposite	1

This data shows that the majority of collisions between HGVs and pedestrians or motorcycles occur when the truck is travelling straight ahead, which would be

expected on the basis of 'exposure', however some may be due to the large blind spot immediately in front of high cabs.

One in four collisions between cyclists and HGVs also occur when the truck is travelling straight ahead. However they are much more frequent when the truck is turning left and the cyclist travelling straight on (65%) confirming the 'classic' scenario.

The lower incidence of reversing accidents in this data compared to ours may be due to the Metropolitan Police study only including accidents at junctions.

2.2 Bus and coach accidents

Of the 64 accidents reported to ICE, only 5 appear to have a driver field of view component:-

- a left turning coach was in collision with a cyclist riding along its near-side, resulting in the death of the cyclist.
- a bus reversing from a stand collided with a pedestrian walking behind the bus, fatally injuring the pedestrian.
- a bus pulling away from a stop knocked over a pedestrian (no injury details).
- a pedestrian, refused entry to the bus, fell under the near-side wheels of the bus, as it pulled away, without the driver being aware.
- a bus entering a roundabout collided with a cyclist already on the roundabout (no further details).

A case of a fatality, recently received from VSE, involved a child falling under the near-side front wheel of a bus. The report states that the design of the near-side mirror system did not permit the driver to adjust the mirrors to give a view of this area.

3. Surveys of operators, manufacturers and drivers

In view of the lack of detailed information available from accident records, these surveys aimed to fill the knowledge gaps in specific areas:-

- problem areas in current vehicle design,
- types of vehicle with specific field of view problems,
- vehicle manoeuvres where field of view is a particular issue,
- any potentially effective solutions which have been implemented.

3.1 Method

Postal questionnaires were designed (see Phase 1 report) and sent to vehicle operators and manufacturers and face-to-face interviews were conducted with drivers. The interview format followed that of the postal survey but included specific prompts to encourage coverage of types of manoeuvre (turning left, turning right, pulling away etc.) and road environments (T-junctions, cross roads, roundabouts etc.)

3.2 Sample

Vehicle operators and manufacturers were identified from appropriate trade directories. Driver interview locations were selected to cover a wide range of vehicles and journey types:-

- Junction 23 truck stop, (Shepshed)
- Securicor, (Loughborough)
- Parcel Force, (Barrow-upon-Soar)
- ARC Quarry, (Shepshed)
- Nottingham City Transport, (Buses)
- Winsons Coaches, (Loughborough)

An initial postal questionnaire response rate of 10% was increased to 24% following a second mail-out to non-respondents.

Table 2: Postal questionnaire respondent rate

Postal Survey	Sent	Returns	%
Truck Manufacturer	16	9	56
Truck Operator	99	19	19
Bus Manufacturer	39	7	18
Bus Operator	104	26	25
Total	258	61	24

Driver interviews	
Trucks	16
Buses	12
Coaches	6
Total	34

3.3 Truck results

3.3.1 Problems identified

Drivers identified the following major problem with vision from trucks areas (listed here with no priority of significance):-

- A near-side blind spot next to the trailer. Some of the driver's who reported this did not have a cantrail mounted, close proximity, mirror to show this area. Those that did said that near-side vision was not a problem;
- Traffic obscured by A-pillars and mirrors when trying to view oncoming traffic to the right (off-side) at roundabouts. It is difficult to see motorcycles approaching at speed. Some criticised mirror size and position;
- Traffic coming from the left at Y-junctions is impossible to see when joining main roads at an angle. Some stated that a wide angle mirror might help in some situations;
- Turning left at junctions was a problem when cyclists try to undertake on the near-side and the driver is unable to see them;
- Driver's need to stop a few feet before pedestrian crossings so that they can see pedestrians crossing in front of the cab;
- When reversing left with an articulated vehicle, normal mirrors only show the side of the trailer and not the rear end;
- Drivers cannot see anything directly behind at all;
- Some articulated vehicles have few windows to the sides and rear of the cab and this makes direct viewing very difficult;

- When changing lane to overtake, the normal offside mirror alone does not offer enough view of the road width to view traffic approaching from behind.

Operators identified the following problems:-

- A near-side blind spot next to the trailer;
- The height of the lower, and some times upper, edge of the windscreen on larger HGVs restricting the view to the front;
- A restricted view along the near-side;
- A restricted view to the rear when reversing;
- 'Driver' issues such as not adjusting mirrors appropriately and installing mascots etc. in the window area.

Manufacturers responses were largely similar to those of the operators but included the following additional observations and comments:-

- The height of the H-point. When the driver's seat is raised to maximum extent, sideways vision for some drivers can be obstructed by the door cantrail;
- Drivers use mirrors that are incorrectly set for the width of the vehicle and it's body. Manufacturers claim this is a common occurrence, reflecting poor operator practices.

3.3.2 Truck types

There are indications from the survey that particular features of some current designs may be improved. These include H-point height in relation to window surround and windscreen dimensions. It would also appear that larger vehicles present greater problems. However, overall the responses from the survey did not clearly identify that problems are restricted to any particular type, make or model of truck.

3.3.3 Truck vision solutions

Three of the manufacturers identified body engineering solutions:-

- positioning mirrors to the requirements of European Directive 71/127/EEC;
- maximising the glazed area of the cab;
- minimising intrusive items, e.g. sun visor, sun blinds, binnacle profile.

Two manufacturers identified alternative technologies which they believed would be most effective in improving the drivers' field of view. These were, remote operated mirrors, heated mirrors, obstacle detectors (close proximity warning beeper, for reversing) and CCTV.

The only method employed by truck operators was the use of a close proximity, cantrail mounted mirror which reduces the near-side blind spot. Operators did not report the use of any other technology to overcome vision problems. Given the reversing problems they had identified we were surprised that none of them referred to the readily available, and not uncommon, reversing alarm systems. However this may be due to them not considering this a 'field of view' issue.

3.4 Bus and coach results

3.4.1 Problems identified

Drivers of buses and coaches identified a number of issues regarding mirrors, reversing and near-side vision which are similar to those affecting truck drivers. They also referred to a number of problems specific to buses and coaches which included, in no order of significance, the following:-

- The width of the rubber safety seals on the closing edges of bi-fold passenger entry doors;
- Screens and body work behind bus and coach entry doors which obscure passengers and two-wheelers at the kerb side;
- Bus number and destination information boards, in the near-side window behind the passenger door, obscuring driver vision to the rear/left;

- Mirrors, especially on the off-side, can obscure forward vision;
- Offside windows with horizontal division bars at eye level;
- Security screens with horizontal cross bars at eye level;
- Transfers on entrance doors;
- Coaches with low position driver's seats have poor vision to the near-side;
- High seat coaches have poor immediate forward vision.
- Mirrors can be located so they are viewed through the side windows or windscreen with no standardisation.

Operators identified similar problems and additionally:-

- Blind spots caused by 'A' and other pillars;
- Wide door pillars;
- High dashboards (binnacles).
- Metal bars on near-side front window adjacent to the luggage rack;.
- Night-time reflections from security screens etc.;
- Poor rear vision making drivers very reliant on exterior mirrors.

Manufacturers identified problems similar to those already identified by drivers and operators i.e.:-

- Central safety rubbers on double opening doors;
- Near-side pillar;
- Wide 'A' pillars;
- High line coaches with no rear window.

3.4.2 Bus and coach types

There are indications from the survey that particular features of some current designs may be improved. Such features include mirror location, door frame/rubber design, locations and shape of body structural pillars etc. Low drivers' seat coaches offer some advantages but also introduce some vision problems. Overall the responses from the survey do not clearly indicate the

problems as being restricted to any particular type, make or model of bus or coach, rather that the issues raised are concerned with the detailed implementation of vehicle features. This is complicated in the bus/coach industry where chassis builder, body supplier and operator modifications result in a wide range of in service vehicle layouts.

3.4.3 Bus and coach vision solutions

Several operators commented on systems used to try and overcome vision problems. Additional mirrors have been implemented by some operators but this will require further investigation to establish the type used. Remote operated mirrors appear to be effective in one case. Practical problems with these seem to stem from costly maintenance mainly due to the high instance of damage in inadvertent contacts and in one case due to vandalism. Obstacle detectors and CCTV are being investigated by 3 operators and as they claim that results seem positive in helping drivers overcome vision problems we shall be following this up during the next phase of the work.

Manufacturers' suggested engineering solutions include extending the windscreen and glass panelling of the doors downwards to give a better close proximity view of the immediate outside area of vehicles.

Drivers believe that increased mirror size would be more of a hindrance than benefit by causing direct visual obscuration.

One coach was observed that included rear view CCTV and the operator is very impressed with the advantages gained from this system.

3.5 Conclusions

The full findings from the surveys of drivers, manufacturers and operators have been tabulated in Appendix 1. However, a summary of the findings are shown in Table 3 below. Essentially, all large vehicle drivers identified the same types of manoeuvre as problematic, regardless of the group of vehicle they were driving - bus, coach or truck.

Table 3: Summary of findings from driver's survey

Manoeuvre	Obscuration	Problem	Main causes
Turning right at T-junction	N/S direct visibility.	Viewing traffic approaching from the left.	Transfers, notices and destination boards in driver's front 180° field of vision. Rubber safety strips on closing edges of bi-fold doors. N/S mirrors positioned at driver's eye level causing obscuration to direct vision.
Pulling in to lay-bys. Returning to left lane after overtaking.	N/S indirect rear visibility	Viewing traffic and other vulnerable road users on N/S.	Wrong type, positioning, size of rear-view mirror. Insufficient mirrors.
Joining a roundabout. Turning right at a junction.	O/S direct visibility	Viewing traffic approaching from the right	Large arrays of forward mounted, O/S, rear-view mirrors. A-pillars and side window division bars too wide.
Joining main road at Y-junction	N/S direct and indirect visibility	Viewing traffic approaching from left-rear of vehicle	Vehicle body work and/or passenger seating obscures vision over driver's left shoulder. Driver's low floor seating position in coaches.
Pulling away from stationary position i.e. traffic lights and give-way signs.	Immediate area forward of cab	Viewing pedestrians walking directly in front of vehicle.	High, rearward driver's seating position. High lower edge to windscreen. Steering wheel and dashboard facias protruding into cab front glazed area.

Reversing straight back and/or around bend/corner	Directly behind vehicle. Area behind articulated trailers when not parallel to tractor unit.	Viewing vulnerable road users positioned outside physical limitations of rear-view mirrors.	Vehicle articulation. No direct rear-view due to vehicle design and/or load.
---	--	---	--

This data has been used in the formulation of criteria for the field of view requirement used for assessing vehicles later in this report.

It is of interest to note that despite the range of problems expressed by drivers, operators and manufacturers, regarding vision from large vehicles, the surveys have revealed relatively little information about attempts to rectify or improve the problems.

4. Vehicle swept paths

Driving a vehicle is a dynamic process so the field of view requirement must accommodate this fact. This dynamic element necessitates that a driver should be able to view vulnerable road users for the entire duration of a manoeuvre. To define this type of requirement it is necessary to understand the way in which a vehicle behaves under the steering demands necessary to make a manoeuvre. The vehicles swept path and the body envelope occupied throughout a manoeuvre is of importance to the driver as it is the area in which interaction with other road users will occur. Information about the swept path and body envelope characteristics of vehicles has been obtained through use of a dedicated software package called 'WinTrack' from Savoy Computing Services Ltd. WinTrack allows the operator to 'drive' vehicles (either those stored in the software's library or those defined by the operator) through 2D road environments that have been drawn and stored in a file format available to most CAD packages. After 'steering' the vehicle through the road layout, WinTrack can then plot wheel tracks, body positions at given intervals, body envelopes and swept paths for the manoeuvre. An example of a WinTrack report showing a double decker bus negotiating a left turn can be seen in Figure. 1 below.

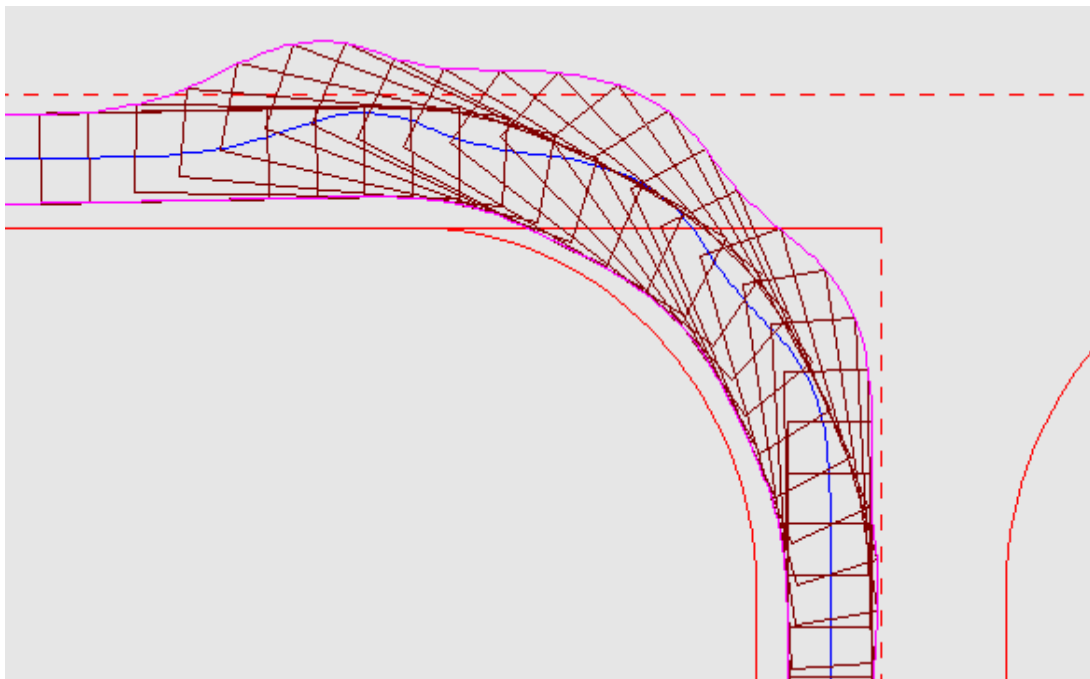

Figure 1: Double decker bus - swept path plot

5. Field of view requirement

The field of view requirement outlines the criteria by which vehicles are currently being assessed in the project. The requirement proposes that a vehicle's design should not obstruct the driver's direct or indirect vision of 'targets', representing vulnerable road users, positioned in areas around the vehicle which have been identified as hazardous. An ideal requirement would probably be 360° vision, for an infinite distance, all around the vehicle. In reality this could prove impracticable. Therefore, obtainable and realistic assessment objectives must be set by the requirement.

Accident data and driver's comments gathered from surveys identified areas of limited visibility from vehicles. However, these tended only to apply to specific driving conditions and situations. The field of view requirement must try to consider the driving task in its virtual entirety so that assessments based upon it will give some degree of confidence in a vehicles' field of view 'performance'.

As a starting point for the field of view requirement it was necessary to consider the area or envelope of space a vehicle will occupy as it manoeuvres through the road environment. As interaction with vulnerable road users can only occur within this envelope it seems reasonable to ensure that this area is covered. The envelope is quite different for articulated and rigid vehicles but the means by which the requirement has been developed for both types of vehicle is basically the same. The process for an articulated vehicle is explained below.

Using the WinTrack software, a 16.5m articulated truck (the longest vehicle commonly permitted on British roads, although legislation permitting drawbar vehicles of 18.75m is imminent and will also be considered) was driven in both forward and reverse directions, from a straight ahead position, to maximum articulation using full steering lock applied as quickly as possible. The plots of tractor and trailer body position at 1.5m intervals and the vehicle's swept path were then plotted (Figure 2).

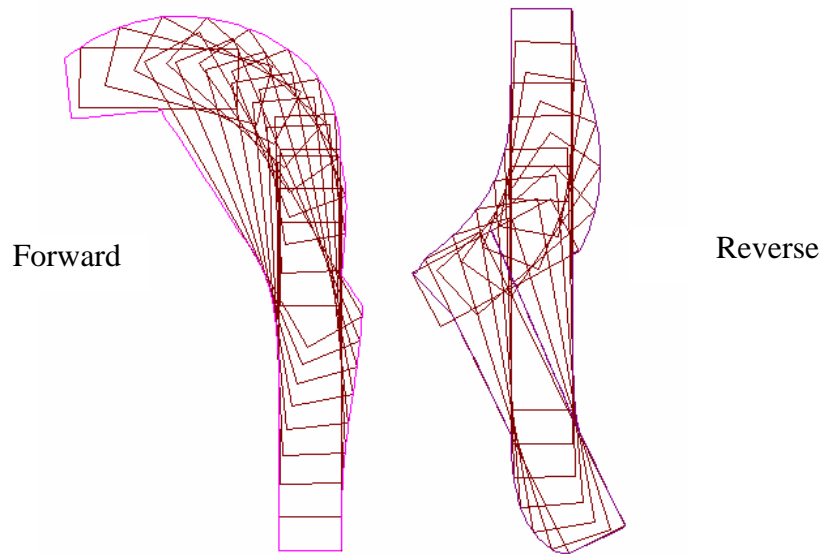

Figure 2: Articulated vehicle swept path plots.

The full extent of the swept path envelope that an articulated vehicle might occupy can now be seen for a forward and reverse manoeuvre under extreme steering conditions. Assuming that most manoeuvres will not be executed under such extreme conditions then the extent of any swept path, using lesser steering demands, would be contained in the areas defined by the boundaries illustrated in Figures 3 and 4.

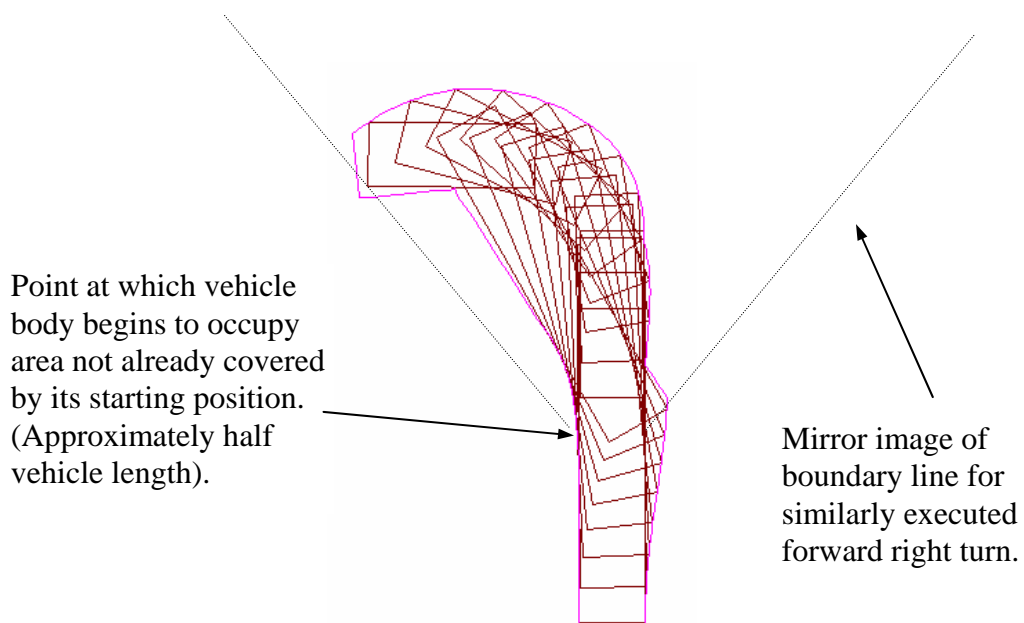

Figure 3: Field of view requirement for forward steering articulated truck.

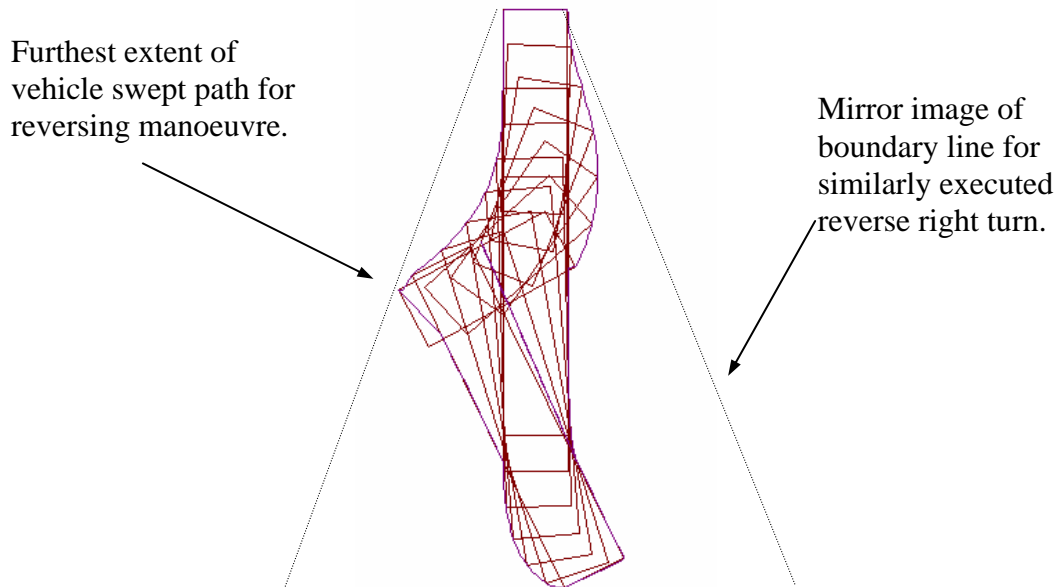

Figure 4: Field of view requirement for reverse steering articulated truck

A further area is defined for the field of view requirement by a semi-circle, the diameter of which runs through the driver's eye points, and with a radius equal to the stopping distance of a large vehicle, including driver's reaction distance, travelling at 56mph governed speed (see Figure 5). This speed limit has been selected because it is the maximum for roads where large vehicles and vulnerable road users e.g. motorcyclists might interact. This stopping distance has been calculated to be approximately 90m. (This figure is based on a braking test carried out by MIRA on behalf of 'Trucking International' magazine using a Mercedes Benz articulated truck fitted with drum brakes and an ABS system).

Finally, areas are included in the field of view requirement which are defined by lines running parallel to the vehicles length. The lines are at a distance of 3.65m from each side of the vehicle equating to the recommended lane width for a district distributor road (see Figure 5).

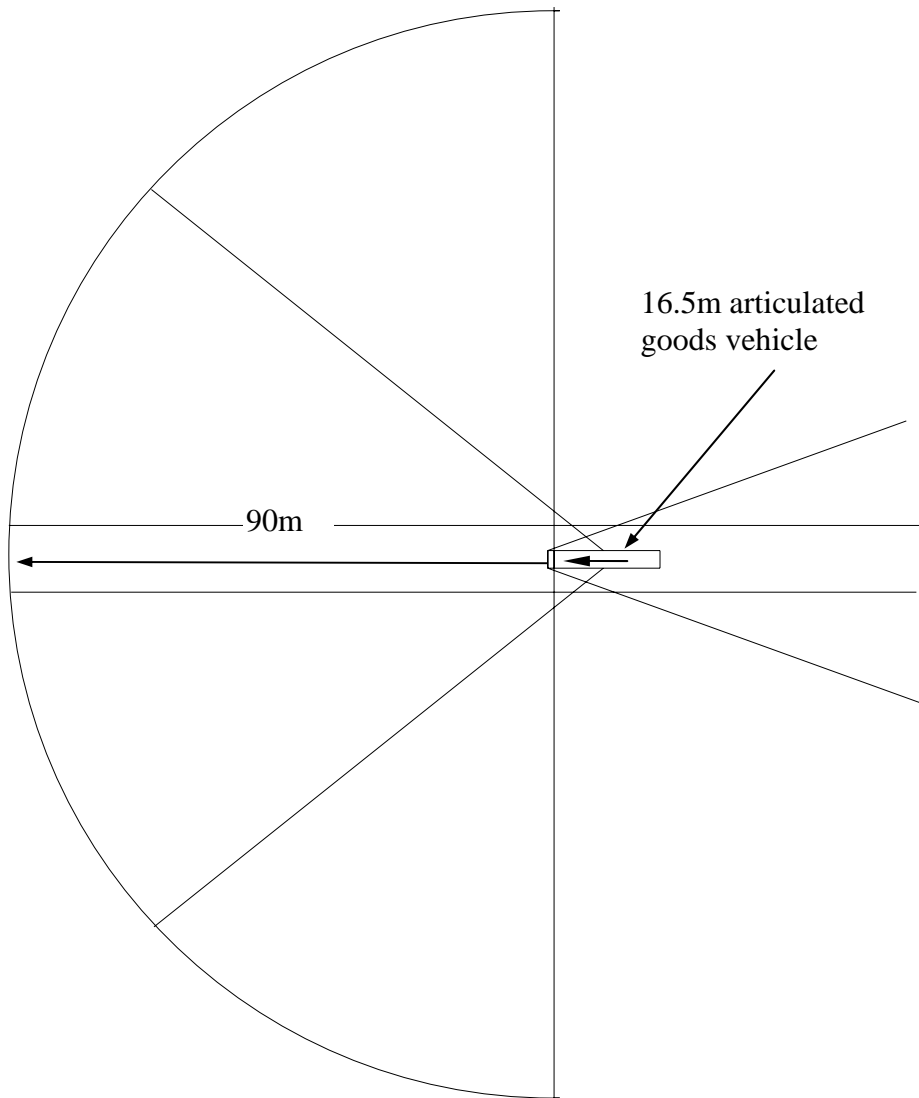

Figure 5: Plan view of drivers' field of view requirement

All areas defined by the field of view requirement have a vertical element equal to 1000mm (for details and explanation see Section 7.4, 'Size and position of FOV targets' page 38).

Having defined an outline field of view requirement there are now criteria against which to appraise current Regulations and Directives (Section 6 of this report) and also to assess the extent existing vehicle design provides drivers with an appropriate field of view (Section 7 of this report).

6. Assessment of fields of view - Regulations and Directives

6.1 Regulations and Directives

The Council of the European Communities categorise the vehicles of concern in this project as:

Table 4: EEC vehicle categories - designation and definition

Category	Definition
M ₂	Vehicles used for the carriage of passengers, comprising more than eight seats in addition to the driver's seat, and having a maximum mass not exceeding 5 tonnes.
M ₃	Vehicles used for the carriage of passengers, comprising more than eight seats in addition to the driver's seat, and having a maximum mass exceeding 5 tonnes.
N ₂	Vehicles used for the carriage of goods and having a maximum mass exceeding 3.5 tonnes but not exceeding 12 tonnes.
N ₃	Vehicles used for the carriage of goods and having a maximum mass exceeding 12 tonnes.

6.1.1 Direct field of view

Currently, the existing European Directive 77/649, relating to direct field of vision, only applies to vehicles in category M₁ - defined in Annex II of OJ No. L225/34 as, 'Vehicles used for the carriage of passengers, comprising no more than eight seats in addition to the driver's seat.'

Directorate General 3 at the European Commission has confirmed that a proposal for an amending Directive, to include larger vehicles (buses and goods vehicles), is currently being considered and should be submitted to member states during the present year (1998).

Although not directly applicable to large vehicles it is useful to review the existing regulations to determine a methodology for regulating minimum field of view requirements and also to identify where regulations will have to be altered or amended so that they might be applied to larger vehicles.

6.1.2 Current direct field of view regulations (M₁ vehicles only)

The following is an overview of the European Directive 77/649 as it relates to M₁ category vehicles.

The Directive states that:-

- There shall be no obstructions, other than those created by A pillars and/or vent window division bars, rear-view mirrors and windscreen wipers, in the driver's 180° forward direct field of vision below a horizontal plane through V₁ and above three planes through V₂, one being perpendicular to the plane X-Z and declining forward 4° below the horizontal and the other two being perpendicular to the plane Y-Z and declining 4° below the horizontal. (Figures 6 and 7).

V points are points whose position in the passenger compartment is determined as a function of vertical longitudinal planes passing through the centres of the outermost designated seating positions on the front seat and in relation to the R point;

- The angle of binocular obstruction of each A pillar shall not exceed 6° (Figure 8).
- No vehicle shall have more than two A pillars.

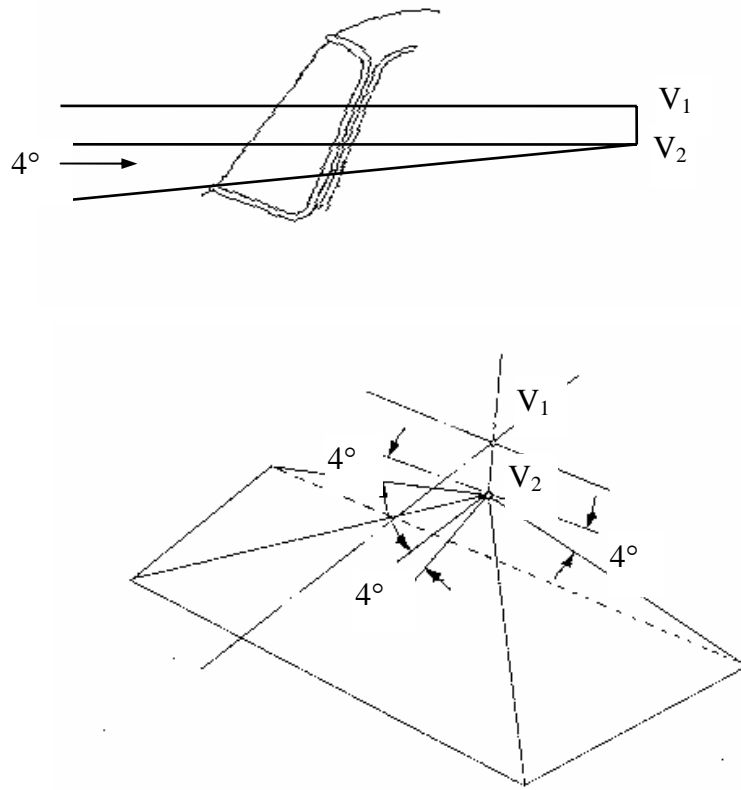

Figures 6 and 7: Direct field of view regulations (M₁ vehicles)

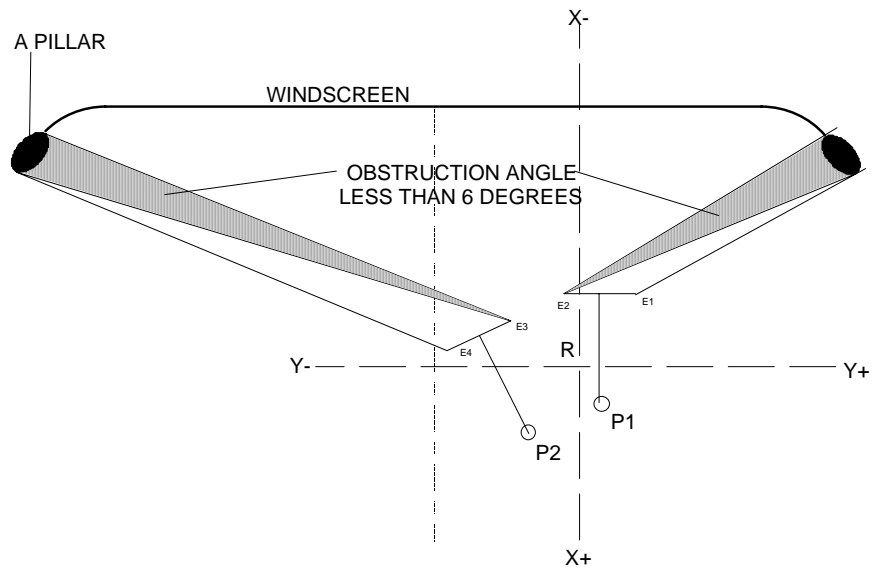

Figure 8. Maximum A pillar obscuration angle

6.1.3 Problems with current direct field of view Regulations

A number of factors have been identified if these direct field of view regulations were to be applied to large vehicles.

(1) The extent of the obstruction permitted in the driver's 180° forward direct field of vision would have to be significantly increased if current designs of large vehicles are not to be excluded by the Directive. As an example, the combined width of body work and rubber safety strips at the closing edges of passenger's, automatic, bi-fold doors in front entrance, single operator buses offer substantial obstruction to driver's direct field of vision within the forward 180° (see Figure 11).

(2) Rear-view mirrors are in the list of permitted obstructions to driver's field of vision for category M₁ vehicles. However, it may be necessary or desirable to place some size restriction in the case of exterior rear-view mirrors fitted to large vehicles. Forward mounted rear-view mirror clusters, housed in aero-dynamic shrouds, as fitted to some modern coaches, now offer significant obstruction to the driver's direct field of vision (see Figure 9). Coach drivers interviewed in the survey, carried out for this report, commented that such mirrors caused a large blind spot in an important area for approaching and entering roundabouts.



Figure 9: Forward mounted rear-view mirror clusters

(3) The current Directive, for M₁ category vehicles, states an angle of 4° below a horizontal plane should be unobstructed by any part of the vehicle other than the items already stated. This angle makes no account for driver's eye height above ground level. The range of driver's eye heights can be extensive in the categories of vehicle under consideration in this report. The driver of a large articulated tractor unit could have an eye height of around 2.6m, while the driver of a low driver position coach could be as little as 1.6m. Taken to extremes, vehicle design, under these conditions, could result in the driver of the articulated tractor unit not being able to see the road in front of the vehicle for 37m, while the coach driver would first see the road at 22m. More realistically, current designs of vehicles in categories N₂ and N₃ can potentially obscure pedestrians walking in front of the cab (see Figure 10).

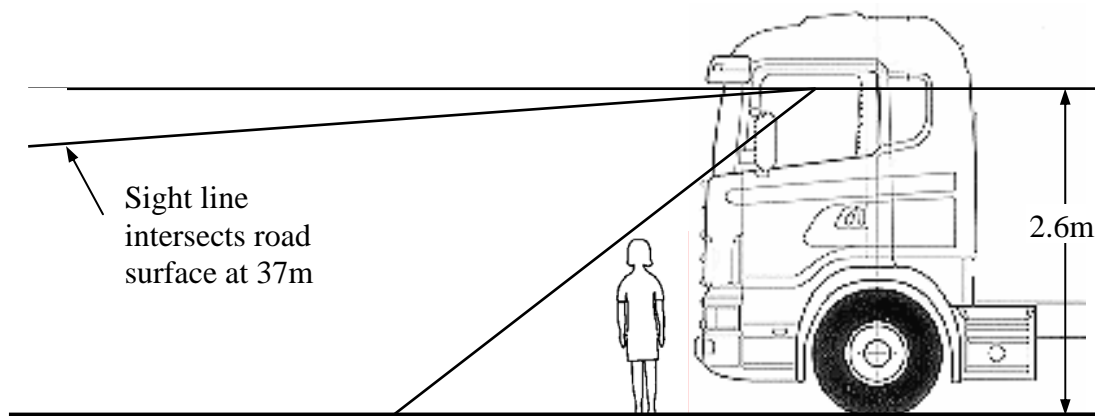

Figure 10: Sight lines from articulated vehicle tractor unit

(4) The construction techniques of some current large vehicles would contravene the existing Directive with regards to A pillar obscuration. Some designs have either, more than one A pillar, or an A pillar offering obstruction to vision greater than 6°. The use of single curved windscreens in some bus construction necessitates what could be defined as a second A pillar. The use of such windscreens improve driver visibility by reducing the amount of light reflected back in to the driver's eyes from bus interior lights at night.

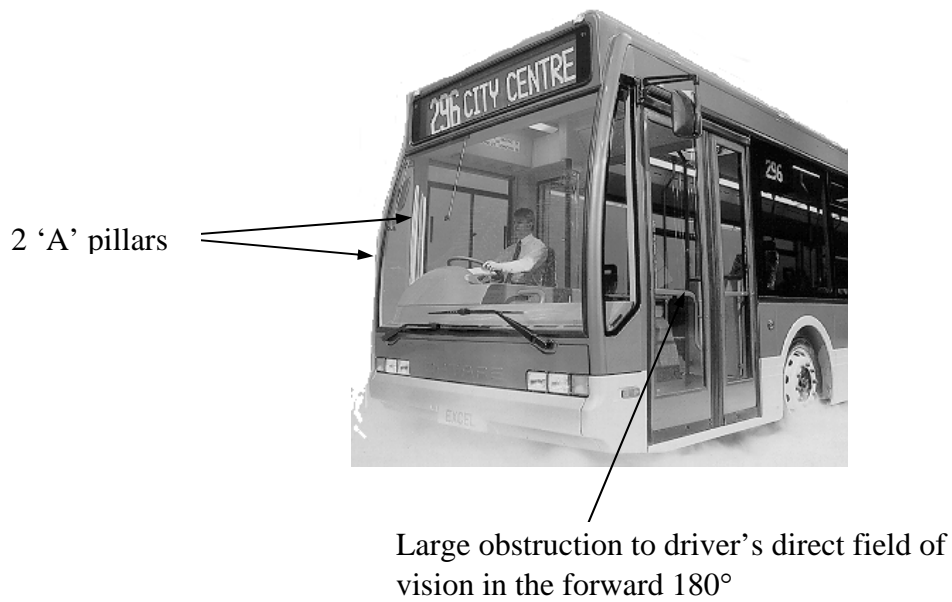

Figure 11: Obscuration in large vehicle due to A pillars and door design

6.2. Current rear-view mirror Regulations

European Community Directives relating to mirror field of view requirements do cover large vehicles in categories N₂, N₃, M₂ & M₃. The requirements are defined by areas on a plane at ground level that must be visible to the driver through the mirrors. The image boundaries are determined by:-

1. The location of mirrors with respect to the driver's eye;
2. The mirror dimensions;
3. The optical characteristics of the mirror.

6.2.1 Method of determining driver's eye points

Driver seated eye heights can range over 160mm and this is further extended by seat height and fore/aft adjustments. In order to define a field of view it is necessary to establish a driver's eye position from which all sight lines originate. The procedure for verifying the relative positions of the R and H points, from which driver's eye points can be determined, are defined in Annex III of Official Journal of the European Communities No. L267.

EEC Directives are written from the perspective of a left hand drive vehicle. The description below has been converted to a right hand drive perspective where appropriate.

Each manufacturer applying for vehicle type approval should specify an R point which is defined relative to primary reference marks.

Primary reference marks are defined as 'holes, surfaces, marks and identification signs on the vehicle body which may be the control points used for body-assembly purposes.'

R-point (seating reference point):-

- Has co-ordinates determined in relation to the vehicle structure;
- Corresponds to the theoretical position of the point of torso/thighs rotation (H-point) for the lowest most rearward normal driving position.

H-point - is the intersection, in a longitudinal vertical plane, of the theoretical axis of rotation between the thighs and torso of a human body which indicates the position of a seated occupant in the passenger compartment.

The R-point forms the origin of a three-dimensional reference grid.

The three-dimensional reference grid is a reference system which consists of a:-

- *Vertical longitudinal plane X-Z (+ve X to rear of vehicle; -ve X to front of vehicle)*
- *Horizontal plane X-Y (+ve Y to right of vehicle; -ve Y to left of vehicle)*
- *Vertical transverse plane Y-Z (+ve Z up; -ve Z down)*

P-points are positioned relative to the R-point.

P-points are points about which the driver's head rotates when he views objects on a horizontal plane at eye level. Two P-points, P₁ and P₂, are defined which account for some relative movement of the torso as the head is rotated.

P₁ and P₂ are positioned relative to the R-point using the three-dimensional grid references.

Table 5. Drivers head rotation point (P) relative to vehicle's 'R' point

P-point	X	Y	Z
P ₁	+35mm	+20mm	+627mm
P ₂	+63mm	- 47mm	+627mm

The eye points E₁ and E₂ are 65mm apart and are a 104 mm from P₁ and P₂.

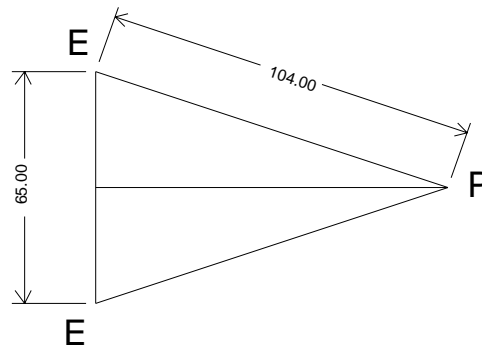

Figure 12: Distance of eye points (E₁ & E₂) relative to head rotation point (P)

6.2.2 Mirror dimensions

There are currently five classifications of rear-view mirror:-

- (1) Class I - Interior rear-view mirrors (*not relevant to large vehicles*)
- (2) Class II - Main exterior rear-view mirrors
 - The dimension of the reflecting surface must be such that it is possible to inscribe therein:
 - a rectangle 4cm high the base length of which has the value 'a'.
 - a segment which is parallel to the height of the rectangle and the length of which has the value 'b'.

The minimum value of 'a' and 'b' are:-

$$a = \frac{17}{1 + \frac{1000}{r}} \qquad b = 20\text{cm}$$

r = radius of curvature

- The field of vision for Class II exterior rear-view mirrors must be such that the driver can see the flat, horizontal portion of the road illustrated below.

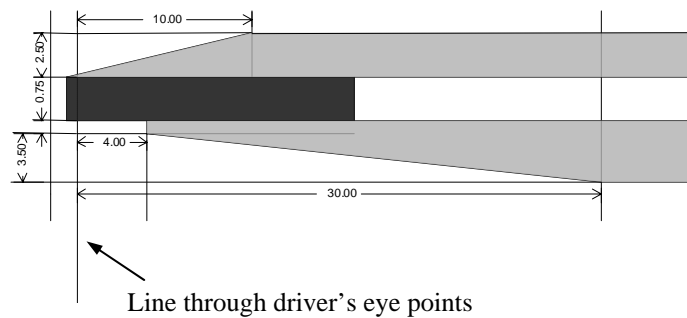

Figure 13: Class II rear-view mirror field of view

- (3) Class III - (*not relevant to large vehicles*)

(4) Class IV - 'Wide-angle' exterior rear-view mirrors

Dimensions must be such that it provides, if necessary in conjunction with Class II exterior rear-view mirror, the field of vision specified below:

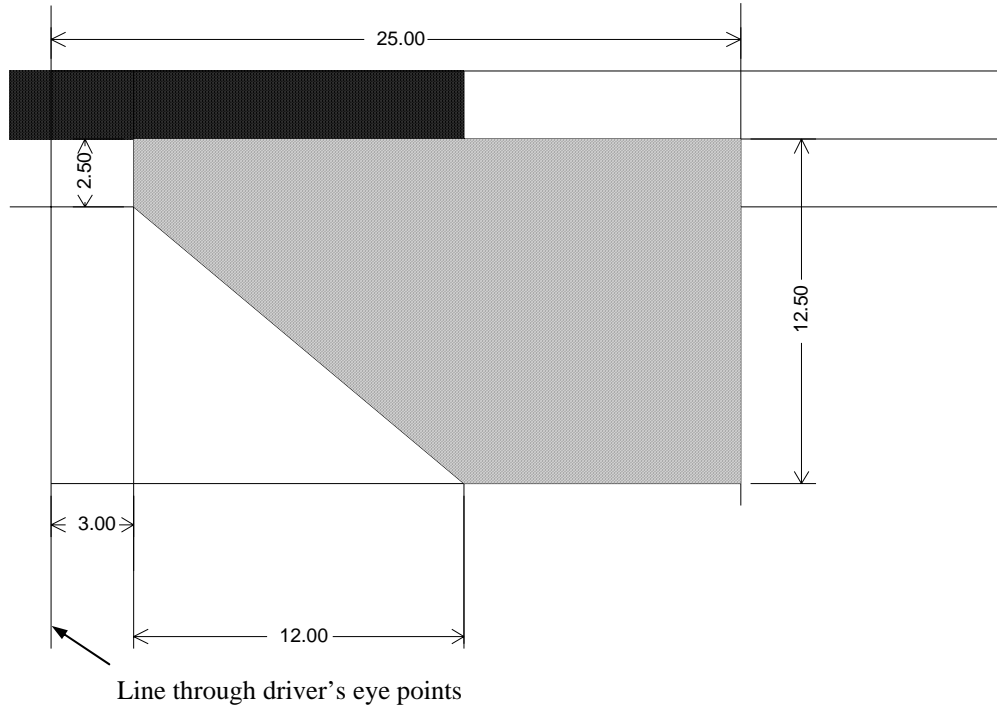

Figure 14. Class IV rear-view mirror field of view

(5) Class V - 'Close-proximity' exterior rear-view mirror.

Dimensions must be such that it provides, if necessary in conjunction with Class II exterior rear-view mirror, the field of vision specified below:

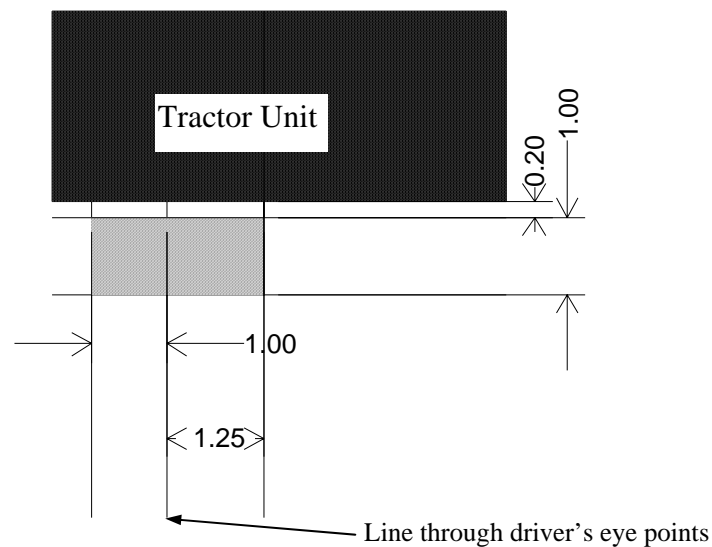

Figure 15: Class V rear-view mirror field of view

6.2.3 Mirror optical characteristics

Calculation of the radius of curvature 'r' of the reflecting surface of a rear-view mirror is the average of three points situated as close as possible to positions at one-third, one-half and two-thirds of the distance along the arc of the reflecting surface passing through the centre of this surface parallel to the segment 'b'.

'r' expressed in mm is calculated from the formula:
$$r = \frac{r_1 + r_2 + r_3}{3}$$

Table 6: Mirror radius of curvature

Mirror Classification	Radius of curvature
Class II	1800 mm
Class IV	450 mm
Class V	450 mm

6.2.4 Minimum number of compulsory rear-view mirrors

Table 7: Minimum number of mirrors required by vehicle category

Vehicle Category	Exterior rear-view mirrors		
	Class II	Class IV	Class V
M ₂	2 (1 on the left and 1 on the right)		optional (see note below)
M ₃	2 (1 on the left and 1 on the right)		optional (see note below)
N ₂	2 (1 on the left and 1 on the right)	optional	optional (see note below)
N ₃ rigid lorries with or without trailers	2 (1 on the left and 1 on the right)	optional	optional (see note below)
N ₃ articulated tractors	2 (1 on the left and 1 on the right)	1	1 (see note below)

Note: Class V rear-view mirrors must be mounted on vehicles in such a way that, regardless of their position after adjustment, no part of these mirrors or their holders is less than 2m from the ground.

6.2.5 Mirror positioning

Exterior rear-view mirrors shall be visible through the side windows or through the portion of the windscreen that is swept by the windscreen wiper (some exceptions for buses and coaches).

The prescribed exterior rear-view mirror on the driver's side of the vehicle must be so located that an angle of not more than 55° is formed between the vertical longitudinal median plane of the vehicle and the vertical plane passing through the centre of the rear-view mirror and through the centre of the straight line 65mm long which joins the driver's two ocular points.

Rear-view mirrors must not project beyond the external body work of the vehicle substantially more than is necessary to comply with the requirements concerning fields of vision.

Where the lower edge of an exterior rear-view mirror is less than 2m above the ground this rear-view mirror must not project more than 0.2m beyond the overall width of the vehicle.

6.2.6 Problems with current rear-view mirror Regulations

Some drivers of large articulated trucks have stated that there is a blind spot adjacent to the near-side wheel of their tractor units. This would appear to be the case when looking at a plan view (Figure 16) of the rear-view mirror requirements, at ground level, as stated in the EEC regulations. This claim, and the need to remedy it, seems to be substantiated by accident data, not only for trucks but also for coaches and buses.

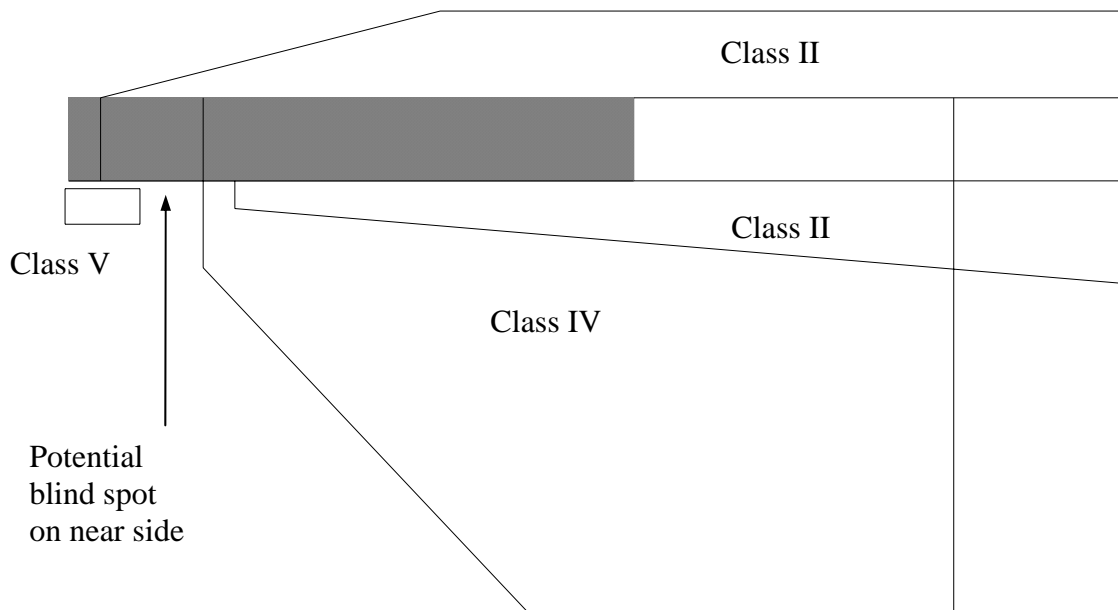

Figure 16: Area not covered by current rear-view mirror regulations

There is no obligation for rear-view mirrors, additional to Class II, on large vehicles other than articulated tractor units. Potentially, this leaves important areas surrounding these vehicles not covered by either direct or indirect field of view Regulations. For instance, the front near-side area of public service vehicles is particularly important as this is an area where high interaction between the vehicle and pedestrians occurs.

Drivers have also expressed concern about limited rear visibility when lane changing on motorways and dual carriage ways. The obligatory Class II mirror, on the off-side, need only permit the driver to see an area extending 2.5 metres parallel to the side of the vehicle. The driver of a large vehicle travelling to the farthest left extent of its lane may well not see a smaller vehicle approaching from behind in the farthest right extent of its lane. This scenario is particularly prevalent when roads are wet and the overtaking car is avoiding spray thrown up by the truck wheels - a situation where visibility is already reduced.

Another area where current mirror regulations may fall short is in their limitation to rear-view capabilities only. An area identified as blind to driver's of large goods vehicles has been the area directly in front of the cab. This area is deemed to be in the forward direct field of view region. However, with current vehicle

designs the elimination of this blind area is, probably, most readily achieved by using mirrors.

7. Assessment of existing vehicle design

7.1 Selection of assessment vehicles

Since neither the accident data or surveys implicated individual vehicles as possessing particular field of view problems it was decided to base the selection of vehicles for assessment on the most common vehicles in service the UK. By analysis of the detailed breakdown, by model and type, of the numbers of large vehicle registrations in recent years vehicles were selected which are representative of those operating on our roads today. It was decided to select three buses, three coaches and three HGV's.

7.1.1 Trucks

Transport Statistics Great Britain (1995) was used to identify the most common load types for rigid and articulated vehicles. These are shown in Table 8 below, where it can be seen that box bodies are the most common load type for both articulated and rigid HGV's:-

Table 8: Most common HGV load type

Articulated (Thousands)							
Box body	Flat lorry	Liquid Tanker	Tipper	Refrigerated	Live-stock	Dropside lorry	Other/not known
11.9	9.4	5.0	2.6	1.8	0.1	0.3	72.3

Rigid (Thousands)							
94.5	27.6	7.8	56.7	11.1	2.7	20.9	91.2

The size of vehicles to be analysed was based on information provided by SMMT for new HGV registrations in the UK for the year ending 1995. It was decided to select vehicles in 3 different size ranges, small medium and large.

Table 9: Goods vehicles over 3.5 tonnes licenced at end of 1994

HGV Type	>3.5 tonnes (Thousands)
Rigid	312
Articulated	103

Table 9 above, shows that there were approximately 3 times more rigid than articulated vehicles licensed on the road in 1994. Thus two rigid and one articulated truck would be included in the sample for assessment. SMMT data shown below (Table 10) provides the 3 most common registered vehicles of each class range for year ending 1995.

Table 10: Highest number of HGV registrations by make and model

Vehicle GVW (tonnes)	Make & model	Total registrations (1995)
7500	Iveco Ford New Cargo	4643
	Leyland DAF Series 45	3994
	Mercedes CVS	2902
> 15000	Mercedes CVS MK	1540
	Iveco Ford Super Cargo	1039
	Volvo FL6	1035
> 32520	Scania SC3	2503
	ERF EC	1352
	Volvo FH12	1253

From the above the following were finally selected so as to cover three different manufacturers and therefore design styles (Table 11). A sleeper cab was also included since their design may present particular visibility problems.

Table 11: Selected HGV vehicles

Vehicle GVW (Kgs)	Make & model		
> 7500	Leyland DAF Series 45	Rigid	Day
> 15000 < 32520	Iveco Ford Super Cargo	Rigid	Day
> 32520	Scania SC4	Artic	Sleeper

7.1.2 Buses & Coaches

Bus & Coach Statistics Great Britain 1995-96 figures show that for new vehicles there are 50,000 single deckers and 20,000 double deckers, including single decker coaches. The most common vehicles are double decker buses and single deckers with 36+ seats. **As the generally older design of double deck buses and stairway to the upper floor probably offer greater vision problems it was decided that two double-deck and one single deck bus would be used for the field of view analysis.**

Data on current vehicle sales was provided by Transport Resources International and identified the following as the vehicles with the highest sales:-

- Buses
 - Optare Excel (Low Floor)
 - Alexandar, Double Deck
 - Northern Counties Palatine Double Deck
- Coaches
 - Joncheere Mistral
 - Van Hool Alizee
 - Plaxton Premiere

7.2 Measuring and modelling of selected vehicles

The design data to enable computer modelling of the selected assessment vehicles was sought from their respective manufactures. However, data on buses and coaches was not forthcoming and the data supplied by manufacturers did not provide all the dimensions necessary for a complete vision analysis.

Therefore, it was necessary to collect dimensional data directly from the vehicles themselves. To do this a professional specification, 3-D digitiser and it's operator was commissioned from MIRA to work with ICE and SAMMIE staff in collecting the required measurements. The digitiser gave three-dimensional co-ordinates of all the points in the vehicles necessary to construct accurate computer models. Access to all the vehicles was granted by local franchised dealerships and operators.

7.3 Modelling of road environments for vehicle manoeuvres

Having accurately modelled the selected vehicles it was necessary to ensure that they have a realistic and representative road environment in which to operate. The vehicle's position relative to kerbs, lane markings and other road users is important in ensuring that a field of view assessment, carried out by computer modelling, is also representative of a real world environment.

From the driver's survey a number of vehicle manoeuvres, and the road junctions associated with them, became apparent as problematic. These road junctions are the ones selected to be modelled and which the vehicles will be 'steered through' to assess the drivers' field of view from them.

The road junctions and layouts were drawn using a simple CAD with dimensions following general practice for British road design (see Table 12 and Figure 17 below for details). The junctions selected are:

Table 12: Details of junction types and dimensions

Road junction or layout	Detailed description
T-junction (1)	7.3m width, single 2-lane district or local distributor road meeting the same with 10m kerb radius
T-junction (2)	6.1m width (min), local distributor, single 2-lane in residential area used by heavy vehicles meeting 7.3m width, single 2-lane district or local distributor road with 6m kerb radius
Y-junction	6.75m width, single 2 lane local distributor road joining 7.3m width, single 2-lane district or local distributor road at an angle of 45°
Roundabout	20m inscribed circle diameter with 11m diameter central island, fed by four 15m width, 4-lane primary distributor roads. Entry kerb radius = 20m, Exit kerb radius = 30m
Dual Carriageway with lay-by type Bus Stop	6.75m width dual carriageway with bus stop for one bus. Lay-by depth 2.6m, 44.6m long from transition to rejoin.
Loading/Dropping Bays (saw tooth layout)	4.0m width bays at 50° pitch. 20m overall width (turning reversing area)

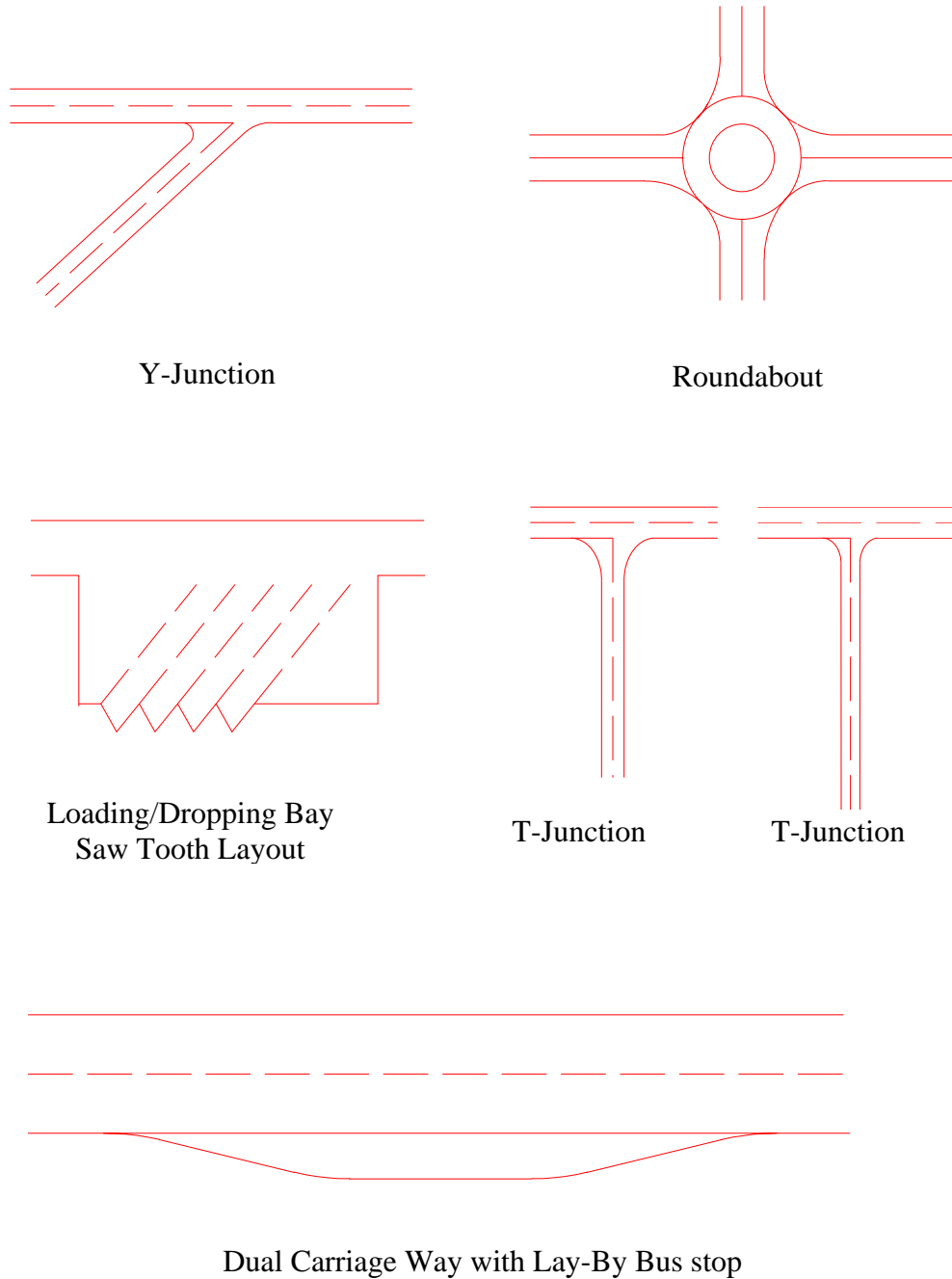

Figure 17. Road junctions and layouts

7.4 Size and position of field of view 'targets'

The 'targets' selected for the field of view requirement have, where appropriate, dimensions based upon anthropometric data for the 5th %ile male or female British population. This represents a worst case scenario likely to be encountered by drivers of large vehicles.

Anthropometric data for stature are based on a 1981, nationwide survey conducted by the Office of Population Censuses and Surveys (OPCS), while the remaining data are calculated using the technique of ratio scaling. Dimensions for bikes, pushchairs and cars are based on recommendations made for architects, planners and designers.

The vulnerable road users and their basic dimensions are listed below and these form the basis for the identification targets in the field of view requirement:-

- Mother with pushchair;
- Elderly woman over 65 years;
- Child aged 8 years;
- Adult cyclist;
- Small family car.

Table 13: Field of view requirement 'target' description

Target description	Stature	Shoulder Height	Shoulder Breadth	Head Breadth	Width
5 th %ile British woman, aged 19-45 yrs	1515	1225	330	135	195 (Chest/Bust Depth)
Mother with pushchair	As above		550 (Width)		1450 (Length, incl. Pusher)
5 th %ile British woman, aged 65-80 years	1475	1190	345	130	220 (Chest/Bust Depth)
5 th %ile British boy, 8 yrs old	1180	930	275	130	115 (Chest Depth)
5 th %ile British boy, 2 yrs old	850	675	215	130	100 (Chest Depth)
Small car	1460 (Height)		1700 (Width)		4500 (Length)
Cyclist	2050 (Height)		600 (Width)		1700 (Length)

(units = mm)

A single target which provides a reasonable compromise across all these dimensions is proposed as a simple rectangle 125mm wide x 1000mm tall.

Appropriately scaled targets are placed in the model road environment at positions identified as hazardous through accident data and driver surveys. The vehicle models are assessed for field of view capability against the requirement. Failure to see targets at any time while negotiating the junctions will identify areas where improvements may be necessary. Recommendations for ways and means of rectifying these short falls in the field of view requirement can then be made. At the time of writing the computer aided assessment of drivers' field of view from the selected vehicles is on going. The following illustrations (based on data from the Scania SC4, articulated, heavy goods vehicle tractor unit) are included to demonstrate the computer modelling output and abilities.

Figure 18: Plan view of Scania SC4 articulated truck with cyclist on nearside. Dark areas = unobstructed driver's view at ground level (for 95%ile driver) Lighter areas = unobstructed driver's view at 1m from the ground (for 95%ile driver). Area A and B show mirror obscuration to direct vision at ground level (light zone) and at 1m (dark zone).

Figure 19: Scania SC4 articulated truck in 3D world view in solid surface form.

**Figure 20: 95%ile drivers view from Scania SC4 articulated truck cab.
Lower (class II) mirror has a reflective lens diameter of curvature of 2100mm.
Pedestrians crossing in front of vehicle cab and cyclist on nearside.**

Appendix 1

Table A: Analysis of bus drivers vision environment

Obscuration	Cause	Road Environment and manoeuvre affected	Comments & Vehicle Types
N/S direct visibility	Cab security screens passenger doors position of mirrors(eye level) N/S corner pillar	Viewing oncoming traffic from left when turning right at junctions	<p>One response also identified glare problems from security screen that was overcome by positioning it at an angle.</p> <p>Another identified security screen with cross bars at eye level.</p> <p>Transfers on entrance doors.</p> <p>Concertina type passenger doors have greater obscuration - generally on older models Scania and Leyland National single deckers.</p> <p>Rubber seal could be reduced in width. Current width is for protection of passengers who may get trapped between closing doors. One driver stated that some rear doors have automatic opening devices. These could be used instead of having increased width seals.</p> <p>Some drivers stated that they will open doors to get a better view on n/s.</p> <p>Screens and bodywork behind passenger door can obscure oncoming traffic at angled junctions.</p> <p>Some vehicles have the bus number in the lower part of the side window - this can obscure traffic and two wheelers in this position (Dennis Arrow 303's)</p> <p>low floor buses offer much better front and n/s viewing. The mirror position will have to be investigated but a lower bus should give a better close proximity view of the vehicle (Optare Excel. Wright body on Scania chassis SD)</p>

O/S direct visibility	O/S mirror obscuration O/S pillar	Viewing oncoming traffic on right at roundabouts and junctions Changing lane	Mirror on some buses positioned at eye level. Should be positioned lower or higher. Optare two o/s pillars cause more obscuration. Some O/S windows have bars at eye level. Volvo SD (601-640) has good side window - no obscuration
Forward visibility	Centre pillar and windscreen wipers High dashboard	Moving off from stationary position. Traffic lights/bus stop Turning right at junctions (Centre pillar)	No one has really stated that this is a problem. However the presence of a centre pillar and vertically central positioned wipers does offer slight obscuration. Problems of viewing people to the front of the vehicle has not been stated as an issue.
Rear visibility	Little or no vision due to advertisements	Reversing anywhere Pulling out from lay-by bus stop on a road bending to left - cannot see oncoming traffic clearly.	Drivers stated that never supposed to use back window for viewing. In many cases the back is completely obscured now with advertisements. Optare Spectra no rear window at all
N/S indirect visibility	wrong type of mirror fitted mirror arms too short Incorrect position	Reversing Pulling in after overtaking Changing lane Pulling into bus stops	Need W/A and kerb mirror to show greater outer view and show close proximity blind spot. Prefer larger mirrors but have to be careful not to hit passengers waiting for bus. 351/2 mirrors can only be adjusted horizontally not vertically. Therefore cannot adjust to view closer to front side of vehicle.
O/S indirect visibility	wrong type of mirror fitted mirror arms too short?	Reversing Changing lane Pulling out of bus stops	Roe bodies have small mirrors so cannot see w/a enough for changing lanes.

Table B: Analysis of coach drivers vision environment

Obscuration	Cause	Road Environment & manoeuvre effected	Comments & Vehicle Types
N/S direct visibility	Side structure of body	Turning right at angled junction	<p>The view to the n/s is obscured by the bodywork at the first passenger position. This is more pronounced in low seat positioned coaches. Low driver seated positions drivers have to ask passengers to look out for them. Some coaches viewed had a window in this position to overcome the problem (DAF Caetano. Plaxton 3200 Paramount H reg). Driver stated that this tended to be in older rather than newer models. Those witnessed are still obscured to stop lookers-in seeing passengers leg positions.</p> <p>Some passenger doors have more glass than others (Bova no lower glass panel)</p>
O/S direct visibility	O/S A pillars and mirror bodywork behind driver	<p>Traffic approaching from right at T junctions</p> <p>Traffic approaching from right at slip roads off motorways</p>	<p>Although vision was obscured because of the presence of the pillar the drivers questioned did not state that it posed a problem, obviously they would prefer it if it was thinner. Almost all mirrors are placed above the drivers field of view and so do not pose a problem. In the case of the long arm mirrors however, an added mirror is positioned in a low vertical position and so causes obscuration. UK law states that drivers must be able to view mirrors through the wiped area of the blade, EC law does not. That is why UK buses require the additional mirror.</p> <p>Some o/s windows have horizontal bars placed at positions that obscure direct visibility of roads and mirrors. Other models just move these up higher to overcome the problem.</p> <p>When coach is positioned at angle</p>

Forward visibility	Higher windscreen line	Moving from a stationary position	In low seat vehicles the windscreen is also lower and so presents less of a problem. The problem obviously increases the higher the driver and windscreen become. The position of the dashboard can also obscure frontal vision. Plaxton 3500 has high seat and dashboard and offers worse frontal vision than lower seated counterpart. Rounded windscreens with a more forward seating position was preferred by all the drivers interviewed. This was witnessed in the Bova.
Rear visibility		Reversing	Some models of coaches have a small window positioned high on the rear which is also obscured by high seating at this point. Only HGV's and other high vehicles can be viewed using the window, not vulnerable road users. Some models have no rear window at all and so there is no visibility. Drivers have stated that they never use the rear window for any manoeuvres requiring rear vision and only use mirrors. Most divers interviewed stated that reversing was the most hazardous manoeuvre in their opinion. CCTV would overcome this problem and contacts have been made with regard to this. This could be followed up further.
N/S indirect visibility	Blind spot near wheel area due to single mirror use	Turning left at junction and exiting roundabout	Most coaches viewed have a single mirror on each side that does not offer visibility towards the front sides of the vehicle or wide of the vehicle. The long arm system has three mirrors that appear to overcome all vision problems.
O/S indirect visibility	Blind spot near wheel area due to single mirror use	Changing lane	Most coaches viewed have a single mirror on each side that does not offer visibility towards the front sides of the vehicle. The long arm system has three mirrors that appear to overcome all vision problems. Mirrors offering views of the outer lanes when changing lanes as well as the close proximity blind spot were considered a better option by drivers. One driver used a convex attachment to the normal view mirror but stated that the image was too distorted to be of any use. A better one was the squarer designs available.

Table C: Analysis of truck drivers vision environment

Obscuration	Cause	Road Environment and manoeuvre effected	Comments & Vehicle Types
N/S direct visibility	A pillars mirrors cab side structure	Turning right at T junction and angled junctions Turning left	Cannot see oncoming traffic from left. Have to try and arrive at junction perpendicular. Increased panelling at side and rear of artics reduces problem. Some cabs have less window area than others. Some vehicles have a lower door window which can be viewed to see other road users
O/S direct visibility	A pillars mirrors	At roundabout	Viewing oncoming traffic from right, particularly two wheelers. Drivers tend to be trained to view traffic as approaching junction to try and avoid stopping.
Forward visibility	High windscreen/cab height	Moving off from stationary position at traffic lights, etc	A pedestrian cannot be seen if close to cab. Drivers tend to stay back a few feet at crossings to allow for this.
Rear visibility	Cab/trailer structure	Reversing	Have to use mirrors for reversing straight back. Cannot see any vehicle that stays directly behind trailer. Residential areas and warehouse dropping zones are problems. Many drivers stated how important warning alarm is. Reversing at angle- some artics have rear window which can be viewed to show reversing path. Reversing to left - blind side reversing - big problem for artics without rear windows.
N/S indirect visibility	Cab height. Position/type/no of mirrors	Blind spot in close proximity to cab trailer area Turning left at junctions Exiting roundabouts	Many vehicles did not have a kerb view mirror and so any pedestrians/two wheelers in this area would not be in view. Taking wide turn to go left cars sometimes try and overtake on nearside of trailer. Angle of cab relative to trailer means that normal view mirror is looking at side of cab and not road (artics), therefore cannot see car/bike and so run over by trailer inwards

O/S indirect visibility	Cab height. Position/type/no of mirrors	Blind spot in close proximity to cab trailer area	Same as N/S but not as critical.
			I believe that lower floor window and front corner mirrors may be designed for close manoeuvring rather than collision avoidance. If this is true it may mean that even though they are present they may not be being used by drivers in the circumstances that we would require them to be.

