

PPAD 9/33/39

Quality and field of vision –  
A review of the needs  
of drivers and riders

Final report

*Prepared for:*

The Department for Transport, Local  
Governments and the Regions

*Prepared by*

Sharon Cook  
Claire Quigley  
Richard Tait

© February 2002

Check \_\_\_\_\_

## **Executive summary**

### **Overview of work undertaken**

Driver/rider vision has been identified as an important determinant to road safety. Its relationship to windscreen/visor tinting, installed light transmission, haze, abrasion, damage/repair and reflection forms the basis of a research programme undertaken by ICE Ergonomics on behalf of the DTLR.

A review of the research to date indicated that there was little, if any, accident data available to quantify the relative contribution of these aspects to road accidents; a finding supported by our own research into accident data in this area. However studies already undertaken suggest that tinting is only problematic for low contrast objects under conditions of low ambient lighting. In addition there is some indication that abrasion and haze (the build up of dirt on the screen interior also referred to as contamination) may be more problematic than tinting.

A review of relevant Directives, Regulations and Standards was undertaken along with specific surveys of driver and rider opinions. These confirmed and prioritised the aspects identified above as problematic to driving/riding. A further survey of visor usage indicated that visors with a luminous transmission of less than 50% (the legal daytime minimum) were available for use on the road and that visors with a luminous transmission less than 80% were frequently used on the road in low ambient lighting conditions. A 20% misuse rate was found in this surveying suggesting that the misuse of visors is a facet of motorcycle riding which needs to be considered when determining limits for luminous transmission levels.

Based on the above research an extensive experimental test programme was developed to investigate key areas in depth. The experimental work was based on the detection of potential roadway hazards under various ambient lighting conditions. Laboratory trials, conducted using a model road, were undertaken to assess a large combination of variables. Those factors which were found to be of most relevance were assessed in field trials to verify the findings. The design of

the trials and the interpretation of the results was undertaken by ICE Ergonomics in collaboration with a peer group of relevant experts in road user vision.

An expert appraisal was undertaken to investigate the alternative types of visors currently available to reducing glare. The results of this appraisal indicated that only a motorcycle helmet peak, a 50% visor, an iridium visor, a two-stage visor (clear outer visor with dark inner visor) and a mirror insert reduced discomfort glare from unacceptable to just acceptable levels. However, aside from the peak (which did not provide benefit against glare from high levels of ambient illumination), these alternatives if misused at dusk or at night on lit roads gave rise to shorter detection distances than the clear visor.

## **Recommendations**

### ***Luminous transmission***

Work indicated that in bright daylight reduced luminous transmission did not improve rider/driver safety since target objects were detected equally well under all luminous transmission levels i.e. there was no significant difference in the detection rates across the various levels of luminous transmission. Previous research, investigations within this study and the expert appraisal suggested that comfort may be a factor in the use of tinted materials.

Under levels of reduced ambient illumination, the results of the trials indicated that the minimum level of luminous transmission could be reduced from 50% to between 47% and 33.4% before there is any significant decrement to detection distance. Since this does not provide the same extent of tint as that defined in BS EN 1836:1997 for dark tinted sunglasses (8-18%) and very dark tinted sunglasses (3-8%) it is suggested that two-stage visors may provide some compromise. Peaks, used to obscure a low sun, are also of benefit. Photochromatic, and perhaps polarised, visors may provide a better solution, but the former are still under development and the authors were not aware of any work on the latter. It should be noted that a minimum transmission level of 12.5% for combinations of materials (e.g. sunglasses & screens) was defined by Morris et al. (1991) for avoiding a reduction in visual acuity, spot detection and contrast sensitivity.

***Abrasion***

The review of research and the information obtained from the survey of motorcyclists suggested that abrasion is not a problem for visors. However windscreens, based on the average from our sample vehicles, should be considered for replacement at 110,000 miles after installation to determine if the detrimental effects of abrasion warrant replacement. Much is dependent upon the extent and type of use, storage, geographical location, etc.

***Haze***

In addition to keeping the outside of the windscreen clean, the interior surface should also be cleaned. Based on our sample, windscreen interiors should be cleaned at least every 859 miles or 19 days.

**Future work*****Luminous transmission***

It would be beneficial to assess the performance of photochromatic, and perhaps polarised, visors when such become available to determine the benefits/disbenefits which they may offer. The performance of these visors should also be assessed against alternatives available at that time. Polarised visors should be similarly assessed.

***Abrasion/contamination***

It would be prudent to increase the sample number and the number of regions surveyed for windscreen abrasion and contamination to ensure nation-wide representation.

***Reflections***

The causes, effects on detection and means of minimising the disbenefits of reflections should be investigated, since this was identified as a primary source of visual problems in the driver survey.

***Fogging***

Visor fogging was identified as an area of concern in the rider survey and in a survey undertaken by the Health and Safety Executive. A method which could be

used to measure the amount of time it took for the clarity of a viewed image to be reduced to 50% and 75% of its original value was devised by Vaughan et al (undated) in response to the HSE survey. Further investigation should be made to determine if this work and ICE's work on veiling glare luminance could form the basis of a future test for motorcycle visors for reduced clarity due to fogging. Fogging was also identified as an area for further investigation with respect to cars since one third of the drivers whom ICE surveyed indicated that they used the car's fan to clear the screen while driving. The acceptable minimum levels to which the screen must be demisted in the shortest possible time, and the areas of the windscreen to which this should be applied, should be further investigated.

***Accident data***

Means to improve the quality of accident data should be investigated. Initial investigations could be made as part of the On-The-Spot study currently being undertaken by the Department.

## Table of contents

|   |    |
|---|----|
| Executive summary.....  | i  |
| 1.0 Introduction.....   | 1  |
| 1.1 Aims of Project .....   | 1  |
| 1.2 ICE Ergonomics.....   | 1  |
| 2.0 Research review .....   | 3  |
| 2.1 Rider vision.....   | 3  |
| 2.2 Drivers vision.....   | 12 |
| 2.3 Alternatives and new developments .....                                       | 31 |
| 3.0 Standards.....  | 35 |
| 3.1 Standards reviewed .....  | 35 |
| 3.2 Summary of standards.....   | 37 |
| 3.3 Rationale for existing standards.....   | 45 |
| 4.0 Accident data .....   | 47 |
| 4.1 STATS19 .....   | 47 |
| 4.2 TRL fatals database.....  | 47 |
| 4.3 The Glasgow database .....  | 47 |
| 4.4 Association of Chief Police Officers ACPO.....                                | 48 |
| 4.5 Automobile Association AA.....  | 49 |
| 4.6 Summary .....   | 49 |
| 5.0 Views of interested parties.....  | 51 |
| 5.1 The current position regarding light transmittance of motorcycle visors ..... | 51 |
| 5.2 Survey of drivers' views regarding quality of vision through car windows..... | 53 |
| 5.3 Survey of motorcyclists' views regarding quality of vision .....              | 59 |
| 5.4 Survey of visor usage.....  | 64 |
| 5.5 Summary of visor usage surveys .....  | 66 |
| 6.0 Luminous transmission trials - Initial laboratory study .....                 | 67 |
| 6.1 The model road .....  | 67 |
| 6.2 Test Variables .....  | 69 |
| 6.3 Test methodology.....   | 72 |
| 6.4 Bright daylight .....   | 72 |
| 6.5 Bright daylight with target objects in shadow .....                           | 73 |
| 6.6 Cloudy, overcast day.....   | 75 |
| 6.7 Low sun condition.....  | 76 |

---

|      |   |     |
|------|---|-----|
| 6.8  | Dawn/Dusk conditions.....                                     | 78  |
| 6.9  | Night time with street lights and headlamps - dry road.....   | 79  |
| 6.10 | Night time with street lights and headlamps - wet road.....   | 80  |
| 6.11 | Night time with headlamps only- dry road.....                 | 82  |
| 6.12 | Summary.....  | 84  |
| 6.13 | Conclusions/recommendations.....                              | 90  |
| 7.0  | Windscreen inclination - Installed luminous transmission..... | 91  |
| 8.0  | Luminous transmission trials – Second laboratory study.....   | 93  |
| 8.1  | Aim.....  | 93  |
| 8.2  | Methodology.....  | 93  |
| 8.3  | Results.....  | 94  |
| 8.4  | Discussions.....  | 99  |
| 8.5  | Conclusions.....  | 101 |
| 9.0  | Luminous transmission trials - Field study.....               | 103 |
| 9.1  | Methodology.....  | 103 |
| 9.2  | Results.....  | 108 |
| 9.3  | Discussion.....   | 111 |
| 9.4  | Conclusions and recommendations.....                          | 112 |
| 10.0 | Expert appraisal of visor alternatives.....                   | 115 |
| 10.1 | Introduction.....   | 115 |
| 10.2 | Methodology.....  | 116 |
| 10.3 | Results.....  | 123 |
| 10.4 | Discussion.....   | 134 |
| 10.5 | Conclusions.....  | 137 |
| 11.0 | Windscreen abrasion trials.....                               | 139 |
| 11.1 | Methodology.....  | 139 |
| 11.2 | Results/findings.....   | 142 |
| 11.3 | Conclusions.....  | 144 |
| 11.4 | Recommendations.....  | 144 |
| 12.0 | Windscreen internal contamination trials.....                 | 147 |
| 12.1 | Methodology.....  | 147 |
| 12.2 | Results/findings.....   | 149 |
| 12.3 | Conclusions and recommendations.....                          | 155 |

|      |  |     |
|------|--|-----|
| 13.0 | Colour identification trials .....               | 157 |
| 13.1 | Methodology .....                                | 157 |
| 13.2 | Results .....                                    | 158 |
| 13.3 | Conclusion .....                                 | 160 |
| 14.0 | Discussion and recommendations .....             | 161 |
| 14.1 | Driver and rider surveys .....                   | 161 |
| 14.2 | Experimental trials – laboratory and field ..... | 161 |
| 14.3 | Expert appraisal of visor alternatives .....     | 162 |
| 14.4 | Abrasion survey .....                            | 163 |
| 14.5 | Contamination survey .....                       | 163 |
| 14.6 | Recommendations .....                            | 163 |
| 15.0 | Future work .....                                | 167 |
| 15.1 | Luminous transmission .....                      | 167 |
| 15.2 | Abrasion and contamination .....                 | 167 |
| 15.3 | Reflection .....                                 | 167 |
| 15.4 | Fogging .....                                    | 168 |
| 15.5 | Additional considerations .....                  | 168 |
| 16.0 | References .....                                 | 169 |

## Appendices

|              |  |    |
|--------------|--|----|
| Appendix 1:  | Invitation to Tender - Work specification references | 1  |
| Appendix 2:  | Standards - Précis of legislative literature         | 9  |
| Appendix 3:  | TRL fatals database                                  | 29 |
| Appendix 4:  | Contacts for project                                 | 31 |
| Appendix 5:  | Driver vision survey                                 | 33 |
| Appendix 6a: | Motocyclists' eye protection survey                  | 43 |
| Appendix 6b: | Visor Usage Survey                                   | 57 |
| Appendix 7:  | Veiling glare luminance trials                       | 59 |
| Appendix 8:  | The lazer revolution helmet                          | 65 |
| Appendix 9:  | Future design considerations                         | 67 |
| Appendix 10: | Field of view report                                 | 69 |





## **1.0 Introduction**

### **1.1. Aim of the project**

It is the aim of the Department for Transport, Local Government and the Regions (DTLR) to provide a safe transport network. Driver/rider vision has been identified as an important determinant of this and factors which impede it require further investigation.

This project is specifically concerned with the effect on driver / rider vision of: windscreen and visor tinting, installed light transmission, haze, abrasion, damage/repair and reflections. Refer to Appendix 1 for a full outline of the project requirements. This included research into the drivers' field of view in passenger cars which is included in Appendix 10.

The research activities undertaken as part of this project and the extensive test programme derived from them are documented in this report.

### **1.2. ICE Ergonomics**

ICE Ergonomics is one of the largest ergonomics research and consultancy organisations in the UK. It was founded in 1970 and is wholly owned by Loughborough University. ICE has over twenty-five years experience in transport ergonomics, particularly applied research into driver vision in the road environment. It has provided advice in this field, based on scientific research, to several government departments thus helping to define both national and EC regulations.

In addition to the relevant specialists at ICE ergonomics, expert personnel from the Transport Research Laboratory (TRL), Defence Evaluation and Research Agency (DERA) and the Applied Vision Research Unit at the University of Derby formed a Peer Group who were consulted in the course of the work.



## **2.0 Research review**

ICE Ergonomic's library undertook a search of relevant internal and external databases. This included its internal collection of over 10,000 paper based items from the field of transport and vehicle ergonomics as well as the access to the databases of Transdoc, the International Road Research Database, Motor Industry Research Association, the Highway Research Information Service and the Transport Research Laboratory.

### **2.1 Rider vision**

Road accident statistics generally tend to show that the rate of motorcycles involved in road accidents is higher than cars. For example, an accident study in Germany found that of 10,000 licensed vehicles in 1983, the number of fatal accidents involving cars was 25, while for motorbikes, it was 62 (Timmerman, 1985). There could be a number of possible contributing factors to the higher level of motorcycle fatalities. The motorcyclist's failure to see the oncoming hazard could be one such factor. This may be a result of the riders own negligent behaviour (carrying out other tasks which takes their attention away from the road ahead) or due to equipment failure (reduced vision through a visor). Vision through a visor can become reduced through dirt accumulation and also, when cleaning the visor, abrasions may occur. A visor fitted poorly to the helmet may also lead to abrasions (Waters, 1982). In addition, vision can be reduced by using a tinted visor.

#### **2.1.1 The Function of Visors and Goggles**

The main function of visors on crash helmets and goggles is to assist with rider vision by preventing the wind, dust particles, dirt and other foreign objects getting into the riders' eyes. However, visors may not assist riders' vision when faced with high levels of glare. Glare has been defined as "the dazzling sensation of a relatively bright light which produces unpleasantness or discomfort, or which interferes with optimum vision"(Phillips and Rutstein, 1965). Road users will

experience two main types of glare on the road. Firstly, glare could occur at night when driving towards oncoming vehicle headlights. It has been shown by a survey carried by the former Road Research Laboratory (now the Transport Research Laboratory) that 15% of oncoming vehicles dazzled drivers (Phillips and Rutstein, 1965). Secondly, daytime glare experienced on sunny days, particularly when the sun is low shortly before dusk and when the sun is shining on wet roads, can be a particular problem to riders of motorcycles.

At present, motorcyclists are required to use helmet-mounted visors or goggles which conform with BS4110 (1979: Specifications for Eye Protectors for Vehicle Users) allowing transmittance levels of no less than 50% during the day, to allow for some daylight glare protection, and no less than 80% at night.

### **2.1.2 Abrasions**

A study by Timmerman (1985) looked at how motorcycle helmet visors can contribute to a loss of clarity of vision, particularly after receiving abrasive damage over a high level of usage. Of the 400 visors in use which were tested, the average scattered light component was calculated at 14.4% (i.e. on average, 14.4% of the visors' surface had scattered light), with moped riders as a group having the worst average scattered light level at 21%. It was also found that moped riders and the less experienced motorcycle riders were generally those who used poor visors in terms of the level of damage and from studying accident data, young inexperienced riders were also those who tended to be the ones who were involved in the most accidents involving injuries. It was therefore concluded that damaged or abraded visors increase the risk of accidents to motorcyclists and that to reduce the likelihood of abraded visors being used on the road, better scratch-resistant materials should be used and a greater awareness of the risks of badly abraded visors should be enforced at rider training level.

### 2.1.3 The use of tinted visors in daylight

Helmet sun visors used by U.S. Navy jet pilots were assessed in terms of their visual acuity in a study by Morris et al. (1991). This report consisted of two studies.

Firstly, the visual acuity of helmeted pilots was tested under four daytime conditions, using high and low contrast stimuli and low contrast under glare, with and without visors of 12% transmission. The results revealed that the threshold of visual acuity was worst when with low contrast stimuli under glare when using a visor and was significantly worse than the reduction in acuity under glare with no visors. This suggests that visors of 12% transmission may reduce exposure to glare but also considerably reduce the visual acuity threshold.

The second study investigated the effects of five visor's transmittance on acuity, spot detection and contrast sensitivity. The transmittances investigated were 100% (i.e. no visor), 50%, 25%, 12.5% and 6.3%. In terms of spot detection, the spot was required to be significantly larger to be seen with 6.3% transmission than with all other filters, while acuity was found to be worse with the same transmission compared with having no filter at all, but no differences were found with other filter transmissions. In terms of contrast sensitivity, filter density was not a significant factor. It was concluded that filter density can be varied over a wide range before significantly affecting acuity, spot detection or contrast sensitivity (down to 12.5% transmission) and suggest that at least  $500\text{cd/m}^2$  should reach the eye when wearing visors or sunglasses. This appears to be in conflict with the currently used BSEN1836:1997, concerning sunglasses which provides for a minimum luminous transmission value of 8% for driving. However, BSEN1938 (motorcycle goggles) appears to have taken this into account by limiting luminous transmittance to a minimum of 18%, the difference probably being due to the categorisation of light transmittance values in BSEN1836.

#### 2.1.4 The use of tinted visors at night

Cooper (1983) undertook research to investigate the effects of tints on the distance at which objects on unlit roads can be seen at night. Practical tests were carried out by measuring an observer's seeing distance of an object positioned just beyond a glare source (dipped headlights). It was found that seeing distance was reduced by about 6% (3 metres) when a tinted visor of 41% transmission was used instead of a visor with 90% transmission. A theoretical method of measuring seeing distances for different degrees of transmission, with and without glare, was also undertaken. The results supported the findings of the practical tests, as a predicted reduction in seeing distance of 3.4 metres was calculated.

Other evidence to support a prohibition of tinting at night was outlined by Wolf et al. 1960, (in McLean et al, 1979), who suggested that tinted glass impedes dark adaptation, visual acuity and depth perception.

The undesirability of the use of tinted visors at night was also commented upon by Gilkes (in Waters, 1982) who found no evidence that the use of tints offer any clear advantage and so to avoid any misuse should not be permitted at all.

In documents forwarded by DETR on "Speed Related Severity To Motorcyclists" and "Reduction in Seeing Distance Caused By Tinted Visors And Its Effect On Motorcycle Impact Velocity", it was reported that reduced visor transmittance leads to reduced seeing distances, therefore impact velocities increase, which in turn increases the chance of a more serious injury occurring. As a result, it was recommended that visor tinting should be prohibited.

An article in the journal "Motor Cycle Rider" (1997) states the case for reducing the allowable daytime minimum transmission of tinted visors from the current level of 50% as specified in BS4110. The motorcycle eye protector BSI sub-committee proposed amendments which included better impact resistance, improved abrasion testing and the use of heavier tints (with 18% transmission) to protect from sun glare. It is stated that to provide riders with effective glare protection, a transmission level of 25% would be necessary. As it is stated in this

article that contemporary research shows that “scratching is the primary cause of accidents” but “heavily tinted visors fail to play a major part”, reducing the minimum transmission tinted visors for use during daylight should not increase accident risks, particularly if interchangeable tinted/clear visor pairs are used which are safer and easier to remove than wearing sunglasses behind a visor.

In 1997, when submitting evidence to the BSI sub-committee, DETR explained why the current minimum transmission for tinted visors should not be reduced from 50% to 18%. A reduction was said not to be appropriate for visors as they are not easy to change or remove when light conditions suddenly deteriorate, which could encourage misuse.

### **2.1.5 Tinting vs Abrasions**

As part of an in-depth accident study carried out by the University of Adelaide Road Accident Research Unit (McLean et al, 1979), trends in motorcycle accidents, including evaluating the effectiveness of existing safety measures, were investigated. Accidents involving riders who were wearing visors were examined to determine the extent to which the visors contributed to the accident. Sixteen of the sixty-nine riders involved in the study had clear visors fitted to helmets. The nine visors which were scratched or dirty were not thought to have affected the riders pre-accident performance. Of the four occasions where clean tinted visors (level not specified) had been worn, it was suggested that one visor may have contributed to the accident, as the rider had failed to see a parked car, but this was one of many factors which could have contributed to the accident.

Another case mentioned in this study involved a rider who was wearing glasses with photosensitive lenses in addition to a scratched tinted visor (level not specified). It was possible that, although the rider was looking downwards to locate a noise, the visor contributed to the accident because the rider again failed to see a parked car. Both this and the previous accident were similar in that they both occurred under night conditions. At the time of publication, the use of tinted visors (less than 85% transmission) was completely prohibited in Australia



(AS1609)(Wigan, 1979) and this study appears to support this at least for night conditions.

An individual case discussed in Waters (1982) involved a rider who was wearing a tinted and abraded visor (34% transmission) at night at the time of driving in to the back of a parked truck (Hope Ide et al. 1981). Visual acuity tests were carried out on the visor to determine the extent to which it would have contributed to the accident. This revealed that the visor did greatly impair vision and that it was the tinting which was more important than abrasion in reducing the vision.

An accident study carried out by Pedder and Hagues (1981), also reported in Waters, found that, of the 117 helmets recovered from fatal accidents, 53 had visors, of which 6 were tinted (level not specified), and one was accompanied with goggles. Nearly half of all the visors were considered abraded enough to impair the rider's vision and four were known to have contributed to causing the accident. Of the tinted visors, one was thought to have contributed to the accident, but this visor was also badly abraded, so it could not be said which was the greater contributory factor to the accident. Therefore, it was concluded that abrasions could be a factor in 8% of motorcycle accidents, but no conclusions could be made about tinting because the sample of tinted visors was very small and all tinted visors were abraded to some extent.

Another study by Pedder and Hague (in Waters, 1982) tested visual acuity on various tinted and abraded visors, again at night. The effect of moderate tinting did not move the visual acuity along the visual acuity scale by more than one point and serious reductions in acuity were not found until there was marked scratching of the visor. It was therefore concluded that "the use of moderately tinted visors down to 50% have not shown to be a serious hazard and, if daytime use continues to be allowed, consequences of occasional inadvertent or deliberate abuse of them don't appear to be likely to be serious". In other words, reductions from 80 to 50% transmission would not cause a serious hazard, but would below 50%.

### 2.1.6 Coloured Lenses

Up to now, the reviewed literature has only reported results concerning visors of neutral density or grey. However, a study into yellow coloured lenses for the purpose of night driving was undertaken by Phillips and Rutstein (1965). They reported on research which found that wearing yellow glasses at night improves subjective discomfort, glare and fatigue, but that visual acuity decreased or was at least no better when wearing glasses tinted with colour. The study by Phillips and Rutstein themselves investigated into how tinted spectacles and contact lenses affect recovery times after experiencing glare from an oncoming vehicle. The results found that although the majority of participants expressed an increase in comfort, their visual performance was worse, i.e. glare recovery times were increased significantly, when wearing tinted spectacles and contact lenses.

### 2.1.7 Visors - Safe Practice

The Department of Transport (1981) have endeavoured to ensure riders do not use tints at night by outlining in a Proposed Manual on motorcycling the uses of visors and goggles. Their advice to riders is to not use when scratched, pull over and clean visors if dirty, not to use tints at night, not to spray tinting material on and to wear corrective lenses if necessary. The use of clean visors is also outlined in a training leaflet published by the Royal Society for the Prevention of Accidents (RoSPA, 1991) aimed at new motorcyclists and the 1978 version of the Highway Code advises the rider “do not use tinted optical equipment of any kind at night or in conditions of poor visibility” (in Waters, 1982).

Wigan (1979) undertook a review of the standards in use at the time in Australia and other parts of the world for automotive eye protection including visors and goggles. In terms of visors, most standards tend to agree on a minimum transmittance level of around 85% for a clear visor, including AS1609, German standard DIN 58218 and US Voluntary Standard VESC-8 (Vehicle Equipment Safety Commission). In addition, VESC-8 also states that a visor with less than 85% transmittance should be considered tinted and should not be used at night. This paper concludes that more research is needed into the extent to which tinted

and abraded visors contribute to the cause of accidents to make specifications more clear cut and until this is done, the quickly replaceable tinted and clear visor pair appears to be the most effective way to overcome conflicts in requirements.

### **2.1.8 Visors - Subjective Opinions**

A number of studies have carried out surveys involving visor users and their opinions on the use of visors. U.S. Navy jet pilots involved in the study carried out by Morris et al.(1991) were asked about visors and sunglasses. It was found that there was much variation in the uses of sunglasses and the types worn. It was suggested by some pilots that a variety of visors with a range of optical densities should be available rather than the single density in use at the time, so they could use the visor which suited them best.

Wigan (1979) reported that users of motorcycle visors prefer clean, unscratched visors to scratched clear visors for use at night and to protect from glare when wearing a clear visor, it was advised by optometrists to wear sunglasses inside the visor. However, there were many disadvantages to this (i.e. potentially increased scatter, physical danger in an accident, difficulty to remove when riding). It was also suggested that users will use alternatives to clear visors if they are unable to wear tinted visors to protect themselves from glare, including no face protection at all and sunglasses with unknown impact protection.

### **2.1.9 Other Aspects which may affect visual acuity through visors**

As well as tinting and abrasions, there was also a limited amount of discussion in the literature concerning other aspects which may affect the quality and field of vision through motorcycle visors, such as fogging and visor rake angle. A report by Vaughan et al. (undated) looked into developing a test method to assess the fogging of complete eye protectors. This study was carried out after it was found from a survey carried out by the Health and Safety Executive that fogging was the main reason why eye protectors were not being used when needed. A method was devised which could be used to measure the amount of time it took for the clarity of a viewed image (in terms of frequency) to be reduced to 50% and 75% of its

original value. It was suggested that this could be of use in the future to test motorcycle visors for reduced clarity in terms of fogging.

It was commented by Wigan (1979) that motorcycle visors are very prone to fogging, and combined with abrasions and dirt, can be more important to the user in terms of reducing vision than tinting. The severity of the rake of a helmet visor, which can often be up to 30°, could also have a negative effect on visual acuity.

Hayward and Marsh (1988) tested how tinted visors with transmission 33.6% affected a riders area of visual field. The results revealed that the area of visual field was no different, with or without the tinted visor. However, this was mainly due to the visual field already being reduced by the helmet thereby possibly making any effect the tint may have had on target detection.

#### **2.1.10 Conclusions to rider vision**

To conclude, the literature tended to suggest that there was difficulty, when considering accident data, in determining the level of contribution of tinting and abrasion to accident causation, as it is rarely the case that a tinted visor involved in an accident will not be abraded as well. It is also often difficult to say whether either were the main cause of an accident.

From the experimental studies, it appears that abraded visors reduced visual acuity more than tinted visors and at a quicker rate. Most studies tend to agree that tinted visors are acceptable at day, sometimes at lower transmissions than the currently accepted 50%, but should be strictly prohibited at night. Interchangeable tinted/clear visor pairs appear to be a more acceptable and efficient way of getting the most out of tinted visors for day and clear visors for night (Wigan, 1979) and helps to reduce visor misuse. This is opposed to the method of wearing sunglasses under clear visors, which some riders have been reported to do. The work of Morris et al. (1991) suggests an acceptable transmission level of 12.5% for combinations of materials (e.g. sunglasses & screens) to avoid reducing visual acuity, spot detection and contrast sensitivity. Therefore, the minimum for testing

could be set at 18% (filter category 2 as described in BSEN1836 - see table 6 in section 3).

Very little research on the fogging of visors was found to be available to evaluate the extent to which it could affect the visual acuity of motorcycle riders and understand the extent to which it could be a problem. However, methods have been developed to determine reduced clarity due to fogging (Vaughan et al, undated).

## **2.2 Drivers vision**

The project scope, as defined in section 1.0 of this report, included an investigation of those factors which affect driver vision. The literature reviewed has indicated that the factors which affect the quality of vision through the windscreen have undergone investigation in the past twenty years as discussed below.

### **2.2.1 Tinting**

There are two opposed bodies of thinking regarding the tinting of vehicle glazing. One body, who would like to see transmission levels lowered, believe that there is a net benefit to the road user population in doing this. The other body hold the opinion that the risk to safety is not outweighed by the benefits tinting provides.

Tinting and accidents

*Benefits*

A common concern expressed by the anti-tinting body is that increased tinting will lead to increased levels of accidents. However, studies by Gittelsohn 1973 and Hills 1976 show this not to be the case. In Hills' work a statistical analysis of more than 6000 accidents indicated that vehicles with tinted windscreens:

- Were not over-represented in day and night-time accidents,
- Did not present an increased risk when used by older drivers at night-time compared to during the daytime (Hills 1976).

However other authors have suggested that there were insufficient statistical controls on this data to be confident that accidents are not increased.

### *Disbenefits*

Little research concerning the affect of tinting on road accidents was found. McFarland et al (in Clark 1993) showed that the night-time accident rate reduces as illumination increases. He argued that since the converse must be true, by increasing the levels of tinting (no levels specified), this is likely to increase the night-time accident rate. It was estimated that the ambient lighting from street lighting, signals, etc would need to be increased by 15% to compensate for the effects of tinting. Similar work by Wolf et al (in Proffitt 1996) found that for a given level of dark adaptation, the threshold for detecting light increases when viewing through tinted glass by an amount corresponding to the reduced transmittance value i.e. it takes 30% more light to see a target through 70% transmittance glass.

In 1991 in Australia, the tinting of the Primary Vision Area (PVA) of the windscreen was decreased from 85% to 75% following pressure from the motor trade. The PVA is defined as the “area of the windshield through which the driver sees the road ahead and its traffic”. Those not in favour of tinting estimated a 2% long-term increase in the night-time road accident rate at an additional cost to Australian road users of \$40million per annum. They concluded that the daytime benefits do not compensate for this (Clark 1993).

Clark also stated that research which states no increase in accidents due to tinting is frequently subject to experimental bias, poor statistics, etc, and therefore must be interpreted with caution.

### Tinting and visibility

#### *Benefits*

Roper (as reported in Zwahlen and Schnell 1994) used square targets of 40.64cm side length and uniform reflectance of 0.075 to be detected at night through a clear windscreen of 88% transmittance and a tinted windscreen of 73% transmittance.

The results of the study showed that using a clear windscreen, initial target

detection distances of 76-123m were obtained. When the tinted windscreen was used night-time detection distances were reduced by 5%. From this work, Roper concluded that daytime heat absorbing benefits outweigh the loss in visibility at night.

A study by Rompe and Engel 1987 (in Taylor undated) found that for low contrast objects at night, subjects with spectacles have poorer detection rates, times and distances than those with normal eyesight. However for high contrast objects, detection was good for both those with and without spectacles. From this it was argued that the benefits of tinting can be gained by applying it to the rear window and since only high contrast objects (e.g. approaching headlamps) are seen at night, transmission levels of 40% are acceptable in rear windows. Even when the rear window transmittances were combined with mirror reflectance losses, which reduced the luminance available to the driver to 12%, test performance was still acceptable.

Prof. Stephen Dain (in Mukherjee 1997) suggests that side window tint levels to a minimum of 35% are acceptable and Mukherjee refers to BS EN 1836:1997 which permits sunglasses to have luminous transmittances as low as 8% for daytime driving (see table 6 in section 3).

However there may be incidents when the detection of low contrast is important eg detecting a pedestrian when reversing at night, and therefore the 40% transmittance proposed above may not be acceptable.

#### *Disbenefits*

**Contrast effects:** A report for the Virginia General Assembly concluded that ‘...window tinting reduces the ability to detect targets that would be difficult to see through untinted glass, and that this could be a safety liability, especially when ambient light is low’. (Proffitt et al. 1996). This is supported by Sayer and Traube, who in their 1994 review of visibility research, stated that ‘The existing literature appears to leave little doubt that motor vehicle window transmittance (no levels specified) can influence a drivers’ ability to detect objects/obstacles, particularly in dusk or night-time conditions.’ US NHTSA suggests that at

twilight a driver is twice as likely not to see a minimal contrast object, such as an unlit bicycle, through 50% transmittance compared to 70% transmittance (the generally agreed standard for windscreens and front side windows).

Rompe and Engel 1987 found that for low contrast objects on the road, accident risk increases greatly for low transmission windscreens (40%). Blackwell (in Hills 1976) similarly concluded that the poorer the visibility of an object, such as a pedestrian in dark clothing, the more detrimental the effects of tinting.

**Physiological effects:** Several studies have shown that reduction in visibility at low luminance levels is more pronounced for spectacle wearers. Weigt 1986 found that spectacle wearers have more inaccurate detections at low contrast levels with tinted windscreens. Rompe and Engel (in Taylor undated) found that low contrast objects have poorer detection rates, times and distances when viewed by spectacle wearers compared to those with normal eyesight. Rompe and Engel 1987 state that this phenomena is most noticeable for transmission levels below 77%. They conclude that the use of low light transmission windscreens (48% & 58%) for those who wear spectacles while driving is unacceptable.

The effects of age on vision when combined with tinting produce similar difficulties in detection at the threshold level (Allen et al 1996).

**Driving effects:** A number of studies have been undertaken to determine the affect of windscreen transmittance on various measures relevant to the driving task. Sayer and Traube 1994 in their research review stated that work by Derkum 1993, Heath and Finch 1953, Owens et al 1992, Rompe and Engel 1987 and Waetjen 1992 indicated the negative effects of reduced transmittance on target recognition and detection, visual acuity, reaction time and driving speed.

**Target detection:** Dunn 1973 (in Proffitt 1996) showed analytically that the probability of target detection decreases with reduced contrast and transmittance values. Contrast sensitivity decreases at a higher rate for transmittance values below 80%. Similarly a study for the Virginia General concluded that ‘..increased levels of window-tinting (from 88% to 13% transmission) were associated with an



increase in the number of failures to detect a pedestrian in rear-view mirrors and with a decrease in the distance needed to detect this target' (Proffitt 1996).

**Distance perception:** A general conclusion by Haber 1955 (in Proffitt 1996) is that distance perception is reduced by tinting. Proffitt 1996 stated that depth perception was reduced by 25-30% when 65-72% filters were used. Research reported by Clark 1993 indicated that objects lit by direct and/or opposing headlights experience a 5-7% reduction in visibility distance. Pedestrians and cyclists (low contrast objects) experience a reduction in visibility distance of 30%. Olson 1996 quoted the findings of previous studies of the visibility distance for clear and tinted windscreens which showed comparative losses ranging up to 6% for tinted glazing whereas Doane and Rassweiler 1955 (in Proffitt 1996) found that tinting reduces detection distance by 3%. Both Heath and Finch 1953, who compared 89% and 71% transmittance, and Dunn 1973, who compared 96% and 78% transmittance, found a reduction in detection distance of 4.5m for reduced transmittance glazing. However Allen et al 1996 state that although losses in visibility distance may be relatively small, they are usually based on the detection targets being lit which is the condition where tinting has least effect on detection. A further study which suggests that detection distances may be underestimated in the literature is the statement by Hills 1976 that independent researchers have found the reductions in night-time seeing distances to be as great as 30-45%.

**Visual acuity:** Proffitt 1996 reports that visual acuity is reduced for targets when viewed through tinted glass. For transmission values of 65-72%, targets size needs to be increased by 10-20%.

A generalisation with respect to tinting, noted by Clark 1993, is that work supporting tinting is undertaken or funded by the motor industry whilst work by independent vision professionals does not support tinting.

Tinting and colour perception

#### *Benefits*

Hills 1976 states that colour vision, visual fields and stereoscopic vision have been shown to be of little or no significance for accident causation.

Mukherjee 1997 suggests that coloration issues can be addressed by using the sun glass standards BS EN 1836:1997.

### *Disbenefits*

It can be shown that windscreens can selectively filter red wavelength and that rake, which increases the distance the light has to travel through the glass, intensifies this effect. Measurements of increased rake resulting in increased absorption are shown in the table below.

**Table 1: Effect of windscreen rake on light absorption**

|       | 0°    |     | 60°   |     |
|-------|-------|-----|-------|-----|
|       | White | Red | White | Red |
| Clear | 88%   | 85% | 79%   | 75% |
| Tint  | 73%   | 60% | 65%   | 49% |

Measurements with a Pritchard Spectra Photometer showed the following transmissions at 60° rake

The table above shows that the effect of tilting and tinting a windshield results in a greater loss of red light transmittance thus making brake lights and signal lights more difficult to detect (Allen et al 1996). Such an effect will be worse for protanopes (those who are red-colour blind) than those who are normally sighted. (A normal colour sighted person looking through a tinted windscreen will experience a reduction in red sensitivity similar to being a protanope. There is evidence to suggest that a protanopic driver wearing sunglasses looking through a tinted windscreen may not see any red light at all!). To compensate for the loss in colour sensitivity a protanope needs about four times the light intensity required by a normal observer to see a red light (Coles and Brown 1966 in Charman 1997).

Clark 1993 stated that spectrally selective sunglasses and tinted windshields may give a combined transmittance as low as 4%. The combination of windscreen, sunglasses and contact lenses has been investigated, but Dain et al (in Sayer and Traube 1994) were only able to conclude that the reduction in transmission presented a risk to drivers which they could not quantify.

### Tinting and glare

#### *Benefits*

Sayer and Traube 1994 found no studies regarding discomfort glare, although Weigt 1986 quotes company car drivers using tinted windscreens who stated that they were not blinded by the headlights of other vehicles at night. However the sample size and the controls used in this survey are not known.

#### *Disbenefits*

Glare significantly effects detection and the closer the glare source the shorter the detection distance with dirty or scratched windscreens. Helmers & Lundkvist 1988 found that it was the increased levels of stray light resulting from the glare which caused the decrease in detection distances. However the detrimental effects of glare from oncoming vehicles are not reduced by transmission, Sayer and Trabue 1994, who also found that there is no relevant research data concerning discomfort glare or veiling glare from reflections from the dashboard.

For daytime glare, AS 1067-1991 (Australian Standard) gives an upper limit to sunglasses as 50% - a level not achievable by windscreens. Clark (1993) states that adequate relief is a function of : wide-brimmed hats, sun visors and sun glasses which are readily removable, rather than through windscreen treatments.

### Tinting and thermal comfort

#### *Benefits*

Mukherjee 1997 claimed improved thermal comfort during the daytime as a benefit of tinted windscreens which is in agreement with Hurst and Scroger 1974 (in Sayer and Traube 1994).

Work by Hills (1976) showed that in a moving vehicle in the daytime, a tinted windscreen reduced the interior temperature by 0.5-1.5° compared to a vehicle with an untinted screen. However, manufacturers now supply glazing with solar properties to achieve temperature reductions without tinting.

*Disbenefits*

Hurst and Scroger 1974 (in Hills 1976) stated that windscreen tinting has a minimal effect on thermal comfort. The heat balance is largely affected by infrared against which the pigments used in the tinting have minimal effect.

Clark 1993 states that 'occupant skin surface temperatures can result in discomfort due to a combination of direct solar radiation and high ambient temperature.

Tinting (no level specified) can reduce this but effect is small and inadequate; light clothing, sun visors and air conditioning are more effective'.

Allen et al 1996 state that the maximum heat that glazing can reduce is 50% because 50% is supplied by visible light. The heat which is absorbed heats the glass and raises the temperature on both sides and then radiates heat. It is estimated that only 25% of the energy can be kept out of the car. Since the window area is responsible for less than 30% of the energy uptake, only 7.5% is eliminated by tinting (level not specified). It is suggested that a white-painted and insulated roof would remove up to 44%.

*Tinting and privacy**Benefits*

Tinting offers privacy and security and offers increased visual appeal (Mukherjee 1997).

*Disbenefits*

Clark 1993 found that for daytime, the apparent luminance of occupants is 85 to 65% for clear screens, but for 75% transmission windscreens this is reduced to 75% to 40%. While tinting offers increased privacy (although there is no literature which specifically addresses this Sayer and Traube 1994) and increased security for occupants, it is said to degrade road safety, encourage risky driving, reduces the ability for road users to make eye contact and limits the ability of the police to see into the vehicle. The study for the Virginia General Assembly concluded that '... in general, higher levels of window tinting made seeing inside a vehicle more difficult'. This resulted in concerns for patrol officers approaching vehicles in the course of their duties. (Proffitt et al 1996). This is in agreement

with the work by Stackhouse and Hancock 1992 (in Sayer and Traube 1994) who examined the ability of approaching personnel to detect various objects, including a firearm, in the vehicle. They found that the subjects were sensitive to changes in the transmission level of the glazing and that this affected their ability to detect the firearm.

Clark 1993 found no literature to support the claim for increased buyer appeal.

#### Summary study

Many of the aspects discussed above are illustrated in the following case study. Four major manufacturers of after market films petitioned NHSTA for a change in regulations to allow film to be applied to the side and rear of passenger car windows reducing transmission to 35%. The film in conjunction with 70% transmission already permitted results in transmission levels of 24.5%. NHSTA invited comment on this proposal from a wide variety of sources. The 78 responses from state agencies/departments dealing with transport safety and law enforcement are given in table 2 below.

**Table 2: Questionnaire responses**

|  |    |
|--|----|
| Endangers law enforcers (cannot see weapons)                                   | 32 |
| Prevents eye contact between road users  | 24 |
| Reduced visibility in darkened conditions                                      | 24 |
| General reduced visibility   | 22 |
| Data promoting increased transmission is not sufficient                        | 18 |
| Current technology is sufficient re: health hazards eg absorbing radiation     | 17 |
| Promotes criminality   | 14 |
| Viewing forward traffic through rear window of car in front is impeded         | 11 |
| Reduced visibility to those with poor eyesight                                 | 9  |
| No guaranteed benefits re: reduction of UV, infrared, reduced temperatures etc | 8  |
| No guarantee of improved safety eg reduced laceration, prevented ejection      | 6  |
| Reduction of glare, haze etc not guaranteed                                    | 5  |
| Fashion accessory  | 3  |

It can be seen from the table that the main concerns are regarding the reduction in visibility out of the vehicle for the driver, particularly in darkened conditions, and a reduction in visibility into the vehicle for other road users (e.g. law enforcers, other drivers), which may encourage anti-social behaviour.

### 2.2.2 General findings

#### Rake angle and transmission

A document by Prof. Stephen Dain, University of New South Wales, (reported in Mukherjee 1997), indicated the following relationship between transmission level and rake angle. Refer to Table 3.

**Table 3: Acceptable rake angle for given transmission levels measured perpendicular to the surface (in order to reach minimum windscreen requirement of 75% at normal incidence)**

| Transmission level | Rake angle<br>(measured from vertical) |
|--------------------|--|
| Untinted (92%)     | 67°                                    |
| 85%                | 61°                                    |
| 75%                | 20°                                    |

Smith and Bryant 1976 (as reported in Mukherjee 1997) showed that rake angles in excess of 60° from the vertical were common.

#### Recommended levels

Dunn 1973 (in Proffitt 1996) showed analytically that the probability of target detection decreases with reduced contrast and transmittance values. Contrast sensitivity decreases at a higher rate for transmittance **values below 80% (exact levels not specified)**.

Rompe & Engel 1987 (in Proffitt 1996) found decreases in visual detection performance for spectacle wearers at levels **below 70% (58% and 40%)** for low contrast targets in simulated twilight conditions.

Weigt 1986 stated that a car glazed with a **windscreen of at least 75%, front-side windows of 70%, rear-side windows of 60% and a back window of 40%** is a good compromise between thermal comfort and driver vision. However the tests were conducted using a front windscreen rake angle of 35° not 60° which would reduce visibility performance further.

Rompe and Engel 1987 (in Taylor undated) suggested **40% to the rear**.

Prof. Stephen Dain (in Mukherjee 1997) suggests that tint levels to a **minimum of 35%** for side windows are acceptable.

### 2.2.3 Haze, Damage and Abrasion

#### Introduction

From the moment a car is first driven on the road, abrasions to the windscreens will occur. Damage to windscreens can be a result of windscreen wiper use, hand cleaning, ice scraping and small particles, such as stones and sand, hitting the windscreen (Allen, 1969, in Helmers and Lundkvist, 1988). An additional source of visual degradation when driving is a greasy layer/film that builds up on the interior surface of a windscreen. This layer has been attributed to a number of contamination sources including atmospheric pollution drawn in when demisting or ventilating, internal pollution from smoking and food and, in the earlier years of a vehicle's life, from particles given off from interior trim plastics under strong sunlight.

The resultant haze and abrasions on windscreens will increase the amount of stray light viewed by a driver. Stray light has been defined as the “light incident on a windscreen which is partially deviated from its original direction by scattering from damaged areas of its surrounding surface” as opposed to useful light which is the “portion of light transmitted without disturbance”. The measurement and effect of abraded windscreens have been discussed in a number of studies.

#### Haze

Allen 1974 (in Sayer and Traube 1994) stated that dirt contributes to reducing drivers visual performance especially under conditions of glare. Glare substantially effects driver visual performance when windscreens are worn (scratched) or dirty due to the stray light produced and the closer the glare source, the shorter the detection distance. (Sayer and Traube 1994). Owens et al 1992 (in





from headlamp glare at night. A means for looking for scratch deterioration is suggested. This involves observing the reflection of the sun (or a stray light source) in the windscreen and seeing whether bright scratch rings show up around the image of the light source, which indicates an older windscreen.

An instrument used to measure scattered light across a windscreen in daylight is described in Timmerman (1986). The results of testing 250 cars using this stray light measuring device found a linear increase in the wear of the windscreens due to impact with small stones with mileage and a more than linear increase of wiper damage. However, it was stated that the level of wear varied among vehicles of identical mileage depending upon the type of use (e.g motorway, urban, country roads).

Allen (1974) undertook tests to determine the amount of surface dirt and damage on a population sample of vehicles. The results of these tests revealed that dirt and abrasion were common in the sample, with windscreen wiper abrasions being particularly prevalent.

To measure stray light caused by windscreen abrasion, a stray light analyser was used by Haase et al, undated. This enabled two values to be found. Firstly, a mean value of the area of the windscreen which is affected by general haze, and a peak value, which is due to scratches and wiper damage. It was found that both mean and peak values increased with the mileage of the car.

Chmielarz et al (1988) also used a stray light analyser to obtain measurements of windscreen damage in selected regions of Germany and Sweden. Significant regional differences were found, contributions to these differences being made by weather conditions, geographical differences and road conditions, which increase the wear to windshields. Other factors which were found to increase the amount of wear included mileage, parking behaviour (garaged better than on the street) and also age. Younger drivers in Germany had vehicles with higher stray light indexes. Reasons given for this were that younger drivers do not keep large enough distances to preceding cars or that they are less likely to be able to afford more recent cars. For these drivers, variables such as windscreen cleaning habits,

smoking habits and the types of roads used by the driver (e.g. city, country roads, motorways) did not make a difference to the amount of windscreen wear (which contradicts the findings of Timmerman, 1986).

Green and Burgess (1981) also measured stray light levels to investigate the effect of worn windshields on driver visibility. Stray light levels were measured using a special measuring instrument similar to the stray light analyser used in the previous studies and also using a laboratory method. The results were compared so that the reliability and validity of the measuring instrument could be investigated. This was found to give similar results to the laboratory method.

#### *The effect of abraded windscreens*

Allen 1974 (in Sayer and Traube 1994) reported that windshield wear contributed to reducing driver visual performance under conditions of glare. This is due to the stray light produced by the windscreen. Derkum 1991 (in Sayer and Traube 1994) measured 28 vehicles windscreens in various conditions of wear and found moderate-to-high negative correlations between the measurement of scattered light and visual acuity.

Rompe and Engel 1984 and 1987 (in Sayer and Traube 1994) showed that target detection is reduced and speed decreased due to the stray light caused by worn screens. Helmers and Lundkvist 1988 (in Sayer and Traube 1994) found that stray light from worn windscreens reduced driver visual performance between 9-25%.

Chauhan and Charman discuss the Mandelbaum effect and the implications it may have on night driving. The Mandelbaum effect occurs when it seems impossible to focus on something in the distance when viewing it through a screen. This could be because given the choice of two targets, a distant one (i.e. the road) and a nearer one which is at the tonic accommodation level (dark focus, resting state) (i.e. the windscreen), the eye will prefer the latter (Owens, 1979, 1984, Adams and Johnson, 1991, in Chauhan and Charman, undated). Testing was carried out to investigate the Mandelbaum effect using both clear and abraded windscreens. However, it was found that rain and scratches produced negligible changes in the accuracy of driver's focusing.

Kessler (1993) discusses how the deterioration of automobile glazing causes stray light by transmission or reflection and how this can affect what the driver can see through the windscreen. Scattered light can often produce “ghost images”, i.e., images of glare sources (e.g. headlights) seen by the driver in other parts of the their field of view, so instead of seeing one glare source, the driver will see two, the original glare source and the same glare source deflected off the windscreen.

The effects of the windscreen damage on static and dynamic driving tasks were measured and an evaluation into how practical resurfacing the damaged windscreen would be was undertaken (Allen, 1974). The results revealed that dirt and abrasion tended to interfere with the view of the road at night. A recommendation was made to increase public awareness of the problem of windscreen damage and replace or resurface windscreens when considerable damage occurs.

The effect on re-adaptation times (using a Landolt ring) after being dazzled by a bright light source when looking through a worn screen and a new screen were investigated (Timmerman, 1986). The results revealed longer re-adaptation times when using a worn screen than a new screen.

Pfeiffer (1970) in Allen (1974) also found reaction times increased as the level of stray light from a windscreen increased when detecting objects in a static simulation of an opposing situation between two vehicles.

Green and Burgess (1981) undertook a study to investigate the effect of various degrees of windshield damage on participants’ response time to safely proceed and on the rate of errors when viewing a road scene at night. Four degrees of damage were used in the tests; undamaged, chipped, moderately damaged and severely damaged. It was found that the rate of errors did not increase as a result of an increase in the severity of windscreen damage, however response times did increase (by up to approximately 8.5%). When adding a glare source to the road scene (i.e. simulated vehicle headlights), error rates were still not affected, but response times increased even more (by up to a further 5%).

Green and Burgess (1981) also reported on an accident study carried out by the Highway Safety Research Institute in 1978 called the Collision Performance and Injury Report (CPIR). Of 9,218 accidents studied, only 39 (0.4%) were reported to have a visibility limitation due to the windscreen condition which was considered to be a potential causal factor of the accident. Two of these were reported to have damaged windscreens prior to the accident which were considered a contributing cause. It was concluded that windscreen damage (e.g. chips and pits) was not the major cause of any of the accidents. Abrasion was not assessed as part of this study.

As part of a series of tests, Timmerman (1986) carried out a test to investigate worn windscreens at night using Scattered Light Index (SLI) as a measure. Object recognition distances were found to be 7% worse with a windscreen of mean SLI of 1.7 (equivalent to a vehicle with a mileage of over 155000miles) than with a new windscreen. Peaks with an SLI of 5.0 were found to be mainly caused by wiper damage. Subjective questioning was also undertaken, which found that a mean SLI of 0.7 or worse was considered to be unsafe for further use (equivalent to a vehicle with a mileage of 103,000miles).

Tests were also carried out by Haase et al. (undated) to investigate the effect of the level of stray light from a windscreen on visibility distances of various objects when encountering an oncoming vehicle. Visibility distance decreased as the stray light index increased and was worsened when the oncoming vehicle low beams were incorrectly positioned. It was concluded that windscreen wear could be a potential contributor to night time accidents as the results show that it causes a reduction in vision at night.

Helmers and Lundkvist (1988) carried out a series of four full-scale experiments into the effect of windscreen damage on object detection distances when viewing lights from an opposing vehicle. The first investigated whether detection distances decreased when introducing a new windscreen compared to having no windscreen at all due to stray light. The results found that there was a small decrease in detection distances with a new windscreen (97 -98% of no windscreen

condition). The second trial looked at differences in detection distances between a new and a worn windscreen. The worn windscreen was found to reduce visibility considerably, particularly when opposing lights were on low beam, as opposed to parking lights, and the target was dark. The aim of the third experiment was to investigate whether any differences could be found between windscreens of similar wear in terms of visibility performance. The differences between the two worn windshields (SLI values of 3.04 and 2.50) were very small. The final experiment investigated whether a relationship between the SLI values of windscreens and target detection distances (under headlight illumination) could be found. Detection distances decreased as the SLI values increased, the decrease being more severe as the glare source increased in intensity, and the relationship was found to be approximately linear. It was concluded that target detection distances were reduced (by 9% to 25%) by an increase in windscreen wear (up to 3.04 mean SLI), bright opposing glare sources and darker targets.

#### **2.2.4 Reflectance**

Sayer and Traube 1994 state that no studies with respect to windscreen reflectance were found. The only additional documentation found by ICE Ergonomics was Allen et al 1996 which provided some general discussion concerning reflection namely that it reduces contrast and increases glare and can be reduced by covering the vehicles dash with a dull black cloth.

#### **2.2.5 Screen bands**

Little research was found concerning the performance of screen bands. A report for the US Department of Transportation, NHSTA, entitled 'The effect of light absorbing media on driver visual performance' recommended that shaded bands should not be used unless they do not enter the drivers line of sight. This is because their intended purpose is to reduce glare; they are not designed to work in the same way as sunglasses. Shaded bands do not protect against the retinal damage which can be caused by wavelengths of 400-1400 nanometers which pass through vehicle glazing. The reduction in discomfort caused by looking through a shaded band, opposed to a clear or tinted windscreen, may not sufficiently

discourage a driver from looking towards the sun e.g. when waiting for a traffic light signal to change, and so may result in retinal damage.

### 2.2.6 Conclusions to driver vision

The research concerning the influence of various aspects of vehicle glazing on driver vision indicates that there is little accident data regarding its effects on road safety. However, what limited data is available suggests that windscreen damage (e.g. chipping and pitting) is the cause of very few accidents (Green and Burgess, 1981) whereas tinting is likely to increase the night-time accident rate (Clark, 1993).

One aspect of vehicle glazing, tinting, is the subject of much debate regarding the extent to which its benefits outweigh its disadvantages when in use on the road. Tinting, which has been the focus of much research in the 1980s and 1990s, appears to be a particular problem for low contrast objects viewed under low ambient lighting conditions (dawn, dusk and twilight) and this is especially the case for spectacle wearers (e.g. at 48% and 58% transmission, Rompe & Engel, 1987). It has been suggested that wearing spectrally selective sunglasses while viewing through tinted windshields may give a combined transmittance of as low as 4% (Clark, 1993) while the work of Morris et al. (1991) suggests that combinations of materials (e.g. sunglasses & screens) must not go below 12.5%. Both of these findings in some way conflict with BS EN 1836:1997 which permits sunglasses to have luminous transmittances as low as 8% for daytime driving. Experimental work has found that tinting reduces detection rates and increases detection distances and can also reduce the ability of drivers to perceive red lights.

As well as front windscreens, suggested minimums were given for side and rear windows. A minimum side window tint level of 35% has been suggested (Dain in Mukherjee, 1997), as has 40% to the rear (Taylor, undated). A car glazed with front-side windows of 70%, rear-side windows of 60% and a back window of 40% (plus a windscreen of at least 75%) has been reported as being a good compromise between thermal comfort and driver vision (Weigt, 1986). However, in a survey undertaken by the NHTSA, inviting comments about a proposed

reduction in transmission of side and rear car windows to 24.5%, concerns were expressed about compromise in safety for both the driver (reduced vision out of the vehicle) and for other road users (reduced vision into vehicle, thereby encouraging anti-social behaviour).

Tinting does offer some reduction in interior temperatures but it is unlikely to be as effective as other means. Tinting also offers increased privacy although this may be detrimental to the eye contact made between road users and to the police when approaching vehicle occupants. Little research has been conducted with respect to glare but tinting is thought to have little effect, if any.

Haze probably has a more detrimental effect on driver vision than tinting. It was reported that a tinted windscreen of 77.4% transmittance and 1.5% haze performed, when detecting targets, on a par or worse than various tinted windscreens of illegal transmittance e.g. 40% (Weigt (1986).

Damage and abrasion are also problematic, particularly from windscreen wipers, hand cleaning, stones and dirt although it depends on the extent and type of exposure. The Highways Safety Research Institute (in Green and Burgess, 1981) concluded that windscreen damage was not the major cause of any of the accidents in its study, while Haase et al. (undated) concluded that windscreen wear could be a potential contributor to night-time accidents as the results show that it causes a reduction in vision at night. Visibility through a worn windscreen was also found to reduce considerably in the presence of a glare source when viewing dark targets (Helmers and Lundkvist, 1988). With damage, response times increase, up to 8.5%, which again increases with a glare source by a further 5% (Green & Burgess, 1981).

Little data was found regarding reflectance, although Allen et al. (1986) reported on the negative effects it has (e.g. reduce contrast and increase glare), which can be reduced by covering the vehicle's dashboard with a dull back cloth. Similarly, little was found regarding screen bands, except that they should not be used in the same way as sunglasses, as this could result in retinal damage (NHSTA, 1973).

## 2.3 Alternatives and new developments

### 2.3.1 Alternatives

#### Reverse tilt windscreen

The problems described in the preceding sections concerning glare, thermal discomfort, etc all arise from the rearward slope of the windscreen which has arisen due to the need for aerodynamic performance. If the angle of tilt of the windscreen was to be reversed this would:

- minimise reflections since the glass would reflect the shaded inside portions of the roof,
- shield against the glare from the reflected light caused by the windscreen dirt,
- be less prone to the effects of frost, collect dew or trap airborne dust on outside,
- be easier to clean inside,
- assist in reducing vehicle lift. (Allen et al 1996).

#### Vehicle and people treatments

A combination of vehicle and people treatments could be employed to alleviate some of the problems caused by current windscreen design.

Thermal reductions can be achieved, for example, by a white roof paint plus roof insulation which would eliminate at least 44 per cent of the solar radiation uptake (Allen et al 1996). This effect can be improved by appropriate use of light clothing, sun visors, wide brimmed hats, sunglasses and air conditioning. This is more effective than the benefits offered by tinting and more flexible according to the ambient conditions (Clarke 1993).

### 2.3.2 New developments

#### Two-stage visors

A recent development with respect to motorcycle visors is the Lazer Revolution (see Appendix 8 for picture). This helmet has an integral sun shield which can be raised and lowered in front of the clear visor (from the rider's view). This is activated by way of a slider on the top of the helmet and, according to the



manufacturers literature, can be used one handed by a gloved hand in less than a second. When the clear lens is in position, the luminous transmission is 78%, with the tinted visor it is 20%. This product was assessed as part of the expert appraisal - refer to section 10.

#### Polarisation

The application of polarisation to visors should be investigated and the benefits/disbenefits to riders considered.

#### Light sensitive glazing

‘Research Frontiers’ proprietary suspended particle device (SPD) technology enables users to electronically and precisely control the passage of light through, windows, sunroofs, sun-visors, mirrors and eyewear, as well as enabling brighter easier to read flat panel displays for computers and other products. SPD film can be controlled automatically by means of a photocell or other sensing or control device, or adjusted manually by the user.’ (Research Frontiers Press Release).

The film (activatable material) is laminated between glass or plastic which have transparent, electrically conductive coatings on their inner surfaces which contact the film. When low-current AC voltage is applied to the film the light absorbing particles within the droplets comprising the film align themselves to produce a clear film. If no voltage is applied the particles lie randomly within the droplets and the film is dark blue. (It should be technically possible in the future to produce black or grey). The extent of light transmission is controlled by the amount of voltage applied. No information was received from the manufacturer about fail safe conditions in the event of equipment failure.

The same technology appears to be under review by Setra, part of EvoBus, specifically with respect to glazed roof panels in coaches. Due to confidentiality, investigations as to the suitability of this technology for windscreens has not been discussed.

Pilkington is also investigating the use of electrochromatic systems with specific reference to vehicle applications.

A number of parties are in the process of developing a photochromatic visor but, to date, none have been available for assessment.

If such a technology could be widely applied in vehicle glazing and rider eye protection the benefits of reduced transmittance by day could be employed without giving rise to disbenefits in conditions of lower ambient illumination.

### **2.3.3 Water and dirt resistant windscreens**

An article by Snooks (1988) looked at the latest window and mirror technology including water and dirt resistant windscreens. These work by applying a special solution which diffuses into the surface of the windscreen and prevents raindrops joining up to form a film. At speeds above 40mph, these drops are blown away by the airflow. As well as raindrop elimination, other benefits to using this solution are that it can help to reduce insect contamination and reduce wiper blade wear.



### **3.0 Standards**

A précis of the legislative literature pertaining to vehicle glazing, windscreen repair and motor cycle helmet visors is given in Appendix 2. It pays particular reference to the visual/optical properties required and the processes of approval testing. The same information is summarised below in a tabulated form.

#### **3.1 Standards reviewed**

##### **3.1.1 Vehicle glazing**

- ISO 3537:1993(E) Road vehicles – Safety glazing materials – Mechanical tests
- ECE Regulation No.43 Uniform provisions concerning the approval of safety glazing and glazing material
- Council Directive 92/22/EEC Safety glazing and glazing materials on motor vehicles and their trailers

##### **3.1.2 Automotive windscreen repair**

- BS AU 242a:1998 Automotive windscreen repair – Code of practice
- BS AU 251:1994 Specification for the performance of automotive laminated windscreen repair systems
- The M.O.T Inspection Manual – Windscreens

##### **3.1.3 Motorcycle helmet visors**

- ECE Regulation No.22 (incorporating 05 series of amendments) Uniform provisions concerning the approval of protective helmets and of their visors for drivers and passengers of motor cycles and mopeds
- BS 4110:1999 Specification for visors for vehicle users

##### **3.1.4 Motorcycle goggles**

- BS EN 1938: 1999 Personal eye protection – Goggles for motorcycle and moped users.



### 3.2 Summary of Standards

**Table 4: Optical performance values for vehicle glazing**

| <b>Optical property</b>                       | <b>Windscreens<br/>(ECE Reg. No. 43)</b>  | <b>Performance of<br/>automotive laminated<br/>windscreen repair<br/>(BS AU 251:1994)</b> | <b>The M.O.T Inspection Manual<br/>- Windscreens</b> |
|---|---|---|--|
| Luminous Transmittance.<br>Light transmission | >75% windscreens<br>>70% windows other than<br>windscreens (9.1.4.1)  |   |  |
| Identification of<br>colours                  | When a windscreen is tinted the<br>following colours shall be<br>identifiable:- (9.4)<br>White - selective yellow - red<br>Green – blue - amber |   |  |

|                    |   |   |   |
|--------------------|---|---|---|
| Optical distortion | <p>A windscreen type will be considered satisfactory if optical distortion does not exceed:-<br/>(9.2.6)</p> <ul style="list-style-type: none"> <li>• 2' of arc (M1 category vehicle, windscreen zone A)</li> <li>• 6' of arc (M1 category vehicle, windscreen zone B)</li> <li>• 2' of arc (M and N category vehicles, windscreen zone I)</li> </ul> | Optical distortion of the repaired area shall not exceed 2' of arc. (8.6) | <p>Light surface scratching in a concentrated area which obscures vision if it meets the fail criteria. (i.e. seriously restricts the driver's view).</p> <p><i>In Zone A</i> (this is a zone of 290mm width, centred on the centre of the steering column and within the swept (wiper) area of the screen) the screen can be rejected if:</p> <ul style="list-style-type: none"> <li>• Damage is not contained within a 10mm diameter circle,</li> <li>• A windscreen sticker or other obstruction encroaches more than 10mm,</li> <li>• A combination of minor damage areas which seriously restricts the driver's view.</li> </ul> <p><i>In the remainder of the swept area:</i></p> <ul style="list-style-type: none"> <li>• Damage not contained within a 40mm diameter circle,</li> <li>• A windscreen sticker or other obstruction encroaching more than 40mm</li> </ul> <p>Repaired screens should be judged as original unrepaired windscreens. An invisible or barely detectable repair, finished flush with the surrounding glass, does not count as damage even if it exceeds the limits given above.</p> |
|--------------------|---|---|---|

|  |  |   |  |
|--|--|---|--|
| Secondary image separation   | <p>A windscreen type shall be considered satisfactory if secondary image separation does not exceed:- (9.3.5)</p> <ul style="list-style-type: none"> <li>• 15' of arc (M1 category vehicle, windscreen zone A)</li> <li>• 25' of arc (M1 category vehicle, windscreen zone B)</li> <li>• 15' of arc (M and N category vehicles, windscreen zone I)</li> </ul>  |   |  |
| Resistance to abrasion<br>Light scatter (%)<br>Light diffusion (cd/m <sup>2</sup> )/lx | <p>Resistance to abrasion will be considered satisfactory if the light scatter as a result of abrasion does not exceed:-</p> <ul style="list-style-type: none"> <li>• 2% for laminated glass windscreens (<i>Annex 6</i>)</li> <li>• 2% for laminated glass panes (<i>Annex 7</i>)</li> <li>• 4% for safety glass panes faced with plastic material (<i>Annex 9</i>)</li> <li>• 2% for the outer face of glass/plastic windscreens and panes and</li> <li>• 4% for the inner face of glass plastic windscreens and panes (<i>Annex 10 and 11</i>)</li> </ul> | <p>The mean value of the light scatter through four repaired areas shall be not more than 4% above the value of the light scatter through the base glass. (8.7.1).<br/>8% after exposure to high humidity. (8.7.2).</p> |  |



|                         |  |   |  |  |  |
|-------------------------|--|---|--|--|--|
| Resistance to radiation | Total light transmittance does not fall below:- <ul style="list-style-type: none"><li>• 95% of the original value before irradiation for windscreens;</li><li>• 70% in the case of panes other than windscreens</li><li>• 75% in the case of windscreens in the zone (9.2.5) where regular transmittance is measured (6.3.1.1)</li></ul> | The total luminous transmittance of the repaired area shall be >95% of the original value before irradiation, and not less than an absolute minimum value of 75%. (8.4) |  |  | Following irradiation the relative change in the luminous transmittance shall be less than $\pm 5\%$ for filters of category 0, less than $\pm 10\%$ for filters of category 1 and less than $\pm 20\%$ for filters of all other categories. (4.6) |
|-------------------------|--|---|--|--|--|

**Table 5: Optical performance values for visors, goggles and sunglasses**

| <b>Optical property</b>                       | <b>Visors</b><br><i>(ECE Reg. No. 22 -<br/>incorporating 05 series of<br/>amendments)</i>  | <b>Visors</b><br><i>(BS 4110:<br/>1999)</i>   | <b>Goggles</b><br><i>(BS EN 1938:1999)</i>                  | <b>Sunglasses</b><br><i>(BS EN1836:1997)</i>  |
|---|--|---|---|---|
| Luminous Transmittance.<br>Light transmission | Visors shall have a luminous transmittance $\tau_v \geq 80\%$ , relative to the standard illuminant D65. A luminous transmittance $80\% > \tau_v \geq 50\%$ is also permissible if the visor is marked 'For Daytime Use Only'. (6.15.3.4). | Filter category 0 shall have a luminous transmittance $\tau_v$ of 80 to 100%.<br>Filter category 1 shall have a luminous transmittance $\tau_v$ of 50 to 80%.   | 18% to 80% depending on filter category (see table 6 below) | 3% to 80% depending on filter category (see following below).<br>Note: 3-8% not suitable for driving and road use.  |
| Spectral Transmittance                        | For wavelengths between 500nm and 650nm the spectral transmittance of the visor shall not be less than $0.2\tau_v$ . (6.15.3.7)  | For wavelengths of 280-315nm, filter categories 0 and 1 shall have a maximum spectral transmittance of $0.1\tau_v$ .<br>For wavelengths of 315-380nm, filter categories 0 and 1 shall have a maximum spectral transmittance equal to $\tau_v$ . | As BS EN1836:1997   | For wavelengths between 500nm and 650nm the spectral transmittance of filters suitable for road use and driving (categories 0, 1, 2, or 3) shall be not less than $0.2\tau_v$ (4.1.2.2) |

|  |   |   |                   |  |
|--|---|---|-------------------|--|
| Recognition of signal lights.<br>Relative attenuation quotient (Q) | <ul style="list-style-type: none"> <li>• 0.8 for red and yellow signal lights</li> <li>• 0.6 for green signal light</li> <li>• 0.4 for blue signal light</li> </ul> | Q ≥ 0.8 for red, yellow, green and blue signal light recognition. | As BS EN1836:1997 | The relative visual attenuation quotient Q of filters of categories 0, 1, 2, and 3 shall be:- <ul style="list-style-type: none"> <li>• &gt;0.8 for red and yellow signal lights,</li> <li>• &gt;0.6 for the green signal light</li> <li>• &gt; 0.4 for the blue signal light</li> </ul> <i>(4.1.2.2.2)</i> |
| Identification of colours  |   |   |                   | The relative visual attenuation quotient of filters of scale numbers 5-1.1 to 5-3.1 and 6-1.1 to 6-3.1 (suitable for driving) for signal lights red, yellow, green and blue shall not be less than 0.8<br><i>(BS EN 172:1994 - 4.2.3).</i>   |

|   |  |   |  |   |
|---|--|---|--|---|
| <p>Resistance to abrasion<br/>Light scatter (%)<br/>Light diffusion (cd/m<sup>2</sup>)/lx</p> | <p>The light diffusion before abrasion shall not exceed 0.65 (cd/m<sup>2</sup>)/lx (test method a &amp; c) or 2.5% (test method b) (7.8.3.2.1.2) <b>Note:</b> Reg 22 Abrasion test is by falling sand method and completed when 3 kg of sand have been projected through a gravity tube). Luminous transmittance measured after the test must not be less than 75% of the pre-test values.</p> | <p>Following UV conditioning and abrasion the visor samples shall show a light scatter value not greater than 10% on either surface (BS 4110:1999 5.5) <b>Note:</b> Abrasion test by revolving wheel method for 100 cycles)</p> | <p>Light diffusion before abrasion =</p> <p>Single lens goggles (Type A)<br/>not to exceed 1 (cd/m<sup>2</sup>)/lx.</p> <p>Multiple lens goggles (Type B)<br/>not to exceed 2 (cd/m<sup>2</sup>)/lx. (Table 1)</p> <p>After abrasion test the goggles oculars shall have a reduced luminance factor of not more than 12 (cd/m<sup>2</sup>)/lx. (4.7.2)</p> | <p>When tested the reduced luminous coefficient of the filters in the new state shall not exceed the value of 0.65 (cd/m<sup>2</sup>)/lx (4.3)</p>  |
| <p>Resistance to radiation</p>  |  |   |  | <p>Following irradiation the relative change in the luminous transmittance shall be less than ±5% for filters of category 0, less than ±10% for filters of category 1 and less than ±20% for filters of all other categories. (4.6)</p> |

**Table 6: Sunglasses and goggle filter categories** (*Table 1 EN1836:1997 and Table 2 EN 1938:1999*)

| <b>Filter category</b> | <b>Description</b>                                      | <b>Range of luminous transmittance(<math>\tau_v</math>) %</b> |     |
|------------------------|---|---|-----|
| 0 Sunglasses           | Clear or very light tint                                | 80  | 100 |
| 1 Sunglasses           | Light tint  | 43  | 80  |
| 2 Sunglasses           | Medium tint   | 18  | 43  |
| 3 Sunglasses           | Dark tint   | 8   | 18  |
| 4 Sunglasses           | Very dark tint<br>Not suitable for driving and road use | 3   | 8   |
| 1 Goggles              |   | 80  | 100 |
| 2 Goggles              |   | 43  | 80  |
| 3 Goggles              |   | 18  | 43  |

### **3.3 Rationale for existing Standards**

Although an extensive literature review was conducted, which identified previous research investigating the effects of degradation on the optical properties of vehicle glazing and motor cycle helmet visors, no published evidence of any previous research having influenced the current legislative performance conditions was found. However it can be seen that there is some similarity between the standards and the preceding research. Similarly, consultation with personnel involved on the various Standards Committees did not identify the scientific basis on which current EC or BSI approval is granted. Reference is made in a DETR document submitted to the BSI visor committee to research carried by TRL in 1983, which influenced the original lowering of the minimum visor luminous transmittance value from 80% to 50%. However this research was not published and so the rationale for the limits is not known to those who were not party to the BSI discussions. As a result of this research and related consideration, a minimum luminous transmittance of 50% was considered to be an appropriate balance between the benefits of tinting in bright conditions and the risks of inappropriate use. No rationale has been found to justify any further reduction below 50%.



## **4.0 Accident data**

### **4.1 STATS 19**

It was proposed that the extent of any road safety issues, caused as a result of poor quality drivers/riders vision, might be assessed through the investigation and analysis of accident data. This methodology has proved unsuccessful or inconclusive for any accident database using the STATS 19 form as its input. Whilst many vehicle, weather and road environment conditions are recorded, no opportunity is provided for gathering information regarding specific vehicle components unless the attending officer has added additional written notes. These notes are not coded and for this reason are not retrievable through database interrogation.

### **4.2 TRL fatals database**

The Transport Research Laboratory (TRL) maintains a database of road traffic accidents involving fatalities. This is compiled using old police reports which contain full details of the accident. Again, details relating to the condition of vehicle glazing or motor cycle crash helmet visors are not entered on the database. Data from this database has been provided and this is reported with other survey information in the section relating to the views of interested parties.

### **4.3 The Glasgow database**

This database is held at TRL and records motorcycle accidents where the rider sustained a head injury. Pre 1994, only accidents involving fatal head injuries were recorded, but since then non-fatal head injuries have been included - data entry ended in February 1998. No information about the visor used at the time of these accidents was entered on to the database but a sample of the visors underwent an investigation for evidence of misuse (tinted visors used at inappropriate times). Only one relevant accident was found which involved a lightly tinted and abraded (scratched) visor which was used at night.



#### 4.4 Association of Chief Police Officers ACPO and police forces

ACPO Traffic Committee stated that driver vision is an area of concern for them. However this was predominantly focussed on aspects of driver eyesight rather than visual interaction with/through vehicle components. Some forces however do have an active interest in this latter area with respect to both riders and drivers and these are discussed below. In general all the UK forces were unable to provide any accurate statistical information, or incident reports in sufficient number, to assist in quantifying those aspects of driver/rider vision which are of concern to this study.

The Accident Investigation Branch of one police force has compiled a database of over 200 cars which have been stopped for having side and rear window light transmittance values less than 70%. Roadside testing is now possible with a portable, hand-held device called "Tintman". While none of these vehicles were involved in road traffic accidents, there is evidence that an accident involving a car pulling out in front of a motor cyclist was due, predominantly, to the fitting of tinting film to the side windows. It is believed that the light transmittance value of the side window, through which the car driver failed to notice the oncoming motorcyclist, was about 16%. This force has provided data from their own survey of motorcycle visors which is reported with other survey information in the section relating to the views of interested parties.

Another police force considered the observed increase in the number of vehicles on the road with tinted glass to be a threat to road safety and undertook an enforcement campaign. Whilst they stated that their prosecution level was at 65% luminous transmission they found that any glass which appeared dark enough to warrant investigation usually had a luminous transmission level of 35% or less. Several prosecutions have also taken place in relation to the use of darkened, non-compliant crash helmet visors. Whilst this police force are aware that the sale of these visors is also prohibited, they consider the current arrangements regarding this to be ineffective due to the large numbers of such helmets in use on the road.

Responses from the Accident Investigation Unit at a further police force indicate their concerns that abrasion and misting are the main problems with respect to motorcyclists' vision.

#### **4.5 Automobile Association AA**

The response from the AA was that the areas of investigation within this study are not aspects about which AA members complain. The only reference which they are aware of in this area is the TRRL 'on-the-spot' accident causation research of the 1970s which suggested that various windscreen defects contributed to about 0.6% of accidents.

More recently, investigations of their own, have lead them to conclude that:

- tinted windscreens should be avoided for use by older drivers,
- old windscreens which have become scratched or pock marked should be replaced.

No statistical information of relevance to this study was available.

#### **4.6 Summary**

Discussions with those given above and other interested groups have confirmed that quality accident data in sufficient number and regional coverage is not available for use without an investment in resources beyond the scope of this study. However such information is necessary if the cost-benefits of amending windscreen and visor design and use is to be determined. It is therefore recommended that investigations be made into the precise nature of the information required and how this may most effectively be obtained, followed by the establishment of a specific database for analysis. Initial investigations could be made as part of the On-The-Spot study currently being undertaken by the Department and STATS19 special projects.



## **5.0 Views of interested parties**

A wide range of individuals and organisations with a specialist interest or expertise related to the scope of the project have been identified and approached by the project team. These include members of the relevant BSI committees, motorcycling organisations, window tinting companies, visor manufacturers, vehicle glazing companies, test houses and others undertaking research directly relevant to the project. Drivers and riders were also surveyed for their opinions. The list of contacts is provided in Appendix 4.

### **5.1 The current position regarding light transmittance of motorcycle visors**

The current position of some of the interested parties with regard to the issue of amending the regulations/standards covering the transmission levels of motorcyclists' eye protection is given below.

Correspondence, dated 1st September 1997, submitted by members of the BSI visor committee PH/25 stated that the current 50% transmittance would not protect against sun glare. The letter cited BS 2724:1987 'Sunglare protectors for general use' which states that for protection from sunglare while driving, filters should have a transmittance of between 29.1% to 17.8%. However it has not been possible to identify the justification for these limits.

A further letter from a practising optometrist and member of the BSI committees PH/2 eye protection and PH/2/1 Sunglasses, provided information on the theoretical benefits of tinting. A tinted lens, was stated to reduce discomfort glare by a factor of its transmittance raised to the power of 0.6. Thus a pale tint with a transmittance of 85% reduces the glare to 0.91 of its previous value, 50% transmittance to 0.65 and 20% (a fairly dark sunglass but in the range allowed by BS EN 1836 for vehicle drivers) to 0.38 of the original glare index.

Based in part on this information, the majority of the BSI visor committee are in favour of permitting visors with a luminous transmittance of 18%, recognising the potential safety disbenefits and suggested the following provisos:-

- that Category 2 visors (18%-43%) should not be used during darkness or conditions of poor visibility,
- that they should be marked 'For daytime use only' or the equivalent (a draft symbol was circulated for comment),
- that it be made a statutory offence under RVLRs to wear a Category 2 visor at night,
- that the means of attaching the visor to the helmets should be manufactured to enable easy fitting and removal without tools to encourage responsible use i.e. changing between 'clear' and tinted as light conditions change.

In addition, RoSPA considered Category 2 filter acceptable only for riders with good eyesight who did not wear spectacles or contact lenses.

In a letter to BSI dated 26<sup>th</sup> Feb. 1998, the then DETR set out in detail their concerns and reasons for not being able to support Category 2 filters. In summary DETR's concerns were based on the lack of any new evidence to suggest that a compelling case could be made on grounds of road safety for a reduction to 18% in addition to previous reduction from 80% to 50%. A major concern was the issue of potential misuse, i.e. riders using darker visors during darkness and poor visibility. They also pointed out that when experiencing glare from low sun, the contrast between bright sun and normal light is such that adequate vision can only be achieved by obscuring the sun completely. DETR suggested that this could best be solved by using a helmet or visor with a removable peak or perhaps by a visor with a graduated tint.

The British Motorcyclists Federation has 130,000 member including affiliates, and over 12,000 individual members. Both the BMF as a member of the BSI visor committee stated that whilst they are interested in the tinting issue, it is not currently a high priority, campaigning issue. They believe that fogging (misting) is a greater issue than abrasion now that the new BS 4110 standard increases the abrasion resistance requirement. They are also concerned that anti-fog/mist surfaces may be too soft and

vulnerable to scratching (interior surfaces) and that fogging may be a helmet design issue i.e. ventilation.

When revising BS4110, BSI visor committee members, with the exception the DETR, proposed and supported a reduction in the minimum luminance transmittance from 50% to 18%, known in the standards as Filter Category 2. However since the standard had to be consistent with national regulations, the minimum light transmittance in the BS remained unchanged at 50%. Some members of the committee were of the view that graduated visors do not address the issue of glare reflected from the road surface.

## 5.2 Survey of drivers' views regarding quality of vision through car windows

A survey was undertaken to seek drivers views on the quality of vision through car windows. Face-to-face interviews were conducted with a random selection of drivers in the Loughborough area to seek information on their experiences of the effects of misting, glare, haze, abrasion and A-pillar design on visibility. The desirability of tinted windows was also explored as an additional means of probing the issues of sun-glare and dazzle.

This survey was conducted in two stages. The first phase was concerned with windscreen misting, cleaning, sun-glare, tinted windows and A-pillar obscuration. The second phase was concerned with windscreen abrasion, damage, repair and reflections. The survey sample details are given in the tables below. Full survey details are given in Appendix 5.

**Table 7: Participant gender ratios**

| Survey 1 |        | Survey 2 |        |
|----------|--------|----------|--------|
| Male     | Female | Male     | Female |
| 14       | 16     | 15       | 21     |

**Table 8: Participant age and years of driving**

|         | Survey 1 |               |         | Survey 2 |               |
|---------|----------|---------------|---------|----------|---------------|
|         | Age      | Years driving |         | Age      | Years driving |
| Average | 42       | 23            | Average | 47       | 25            |
| Minimum | 21       | 4             | Minimum | 22       | 3.5           |
| Maximum | 72       | 54            | Maximum | 75       | 55            |

**Table 9: Age of vehicle**

| (Years) | Survey 1   |                |         | Survey 2   |                |
|---------|------------|----------------|---------|------------|----------------|
|         | Age of car | How long owned |         | Age of car | How long owned |
| Average | 7.3        | 2.9            | Average | 7.6        | 4.0            |
| Minimum | 2          | 0.1            | Minimum | 0.5        | 0.25           |
| Maximum | 15         | 13             | Maximum | 17         | 12.5           |

### 5.2.1 Windscreen misting

Two thirds of the drivers reported that their windscreen sometimes or often misted up (21/30). As might be expected this mainly occurred under damp conditions (rain, damp occupants) and when the weather was cold - cold, early mornings being cited on a number of occasions.

Nearly all drivers clear the screen with the car's fan (20/22) and 7/22 said that they sometimes or often had to do this while driving. If this latter point is substantiated then it implies that a not insignificant proportion of drivers regularly drive with reduced visibility through the windscreen.

### 5.2.2 Windscreen cleaning

The film of dirt which gradually accumulates on the interior surface of the windscreen not only reduces light transmission but also encourages moisture to condense on the

screen leading to misting. The dirt film also causes a proportion of light passing through the screen to be scattered resulting in a veiling luminance (haze).

Of 26 replies, 7 drivers had cleaned their screen within the last week, 13 within the last month and 6 less recently than this. The majority (21/29) do not clean the screen regularly but just when they notice it is dirty. Whilst any conclusions which may be drawn from this must be tentative, given for example that we do not know at present the rate at which dirt accumulates on windscreens, we should consider that a significant proportion of windscreens could be suffering haze and misting unnecessarily.

Having stated the above, 23/30 stated that they rarely or never experienced problems with vision due to accumulated dirt on the inside of their car windows.

### **5.2.3 Windscreen abrasion**

Of the 36 drivers who completed the questionnaire, 10 stated that at some stage in their driving experience, they had required a new windscreen to be fitted to a vehicle they had owned, the time elapsed since the last time this had happened ranging between 3 days and 20 years. When asked about the extent of abrasion on their current vehicle's windscreen, just over half of the drivers reported that their windscreen was not abraded at all (19/36). Of those who did report abrasion, 4 found their windscreen to be somewhat or very abraded.

Windscreen abrasion had caused vision problems for 5 of the 36 drivers, with it being a problem 'rarely' or 'sometimes'. Abrasion was said to cause vision problems when driving towards poorly adjusted headlights of oncoming cars, driving towards a low sun and looking through a misted windscreen. One driver suggested the abrasion was caused by use of the windscreen wiper. Only one respondent found abrasion to be more than a slight problem. Of the 5 respondents who found abrasion to be a problem, 3 were able to reduce the problem. This was achieved by de-misting the screen before driving away, using good quality wiper blades and using a compound to remove the scratches at driver's eye point.



#### **5.2.4 Windscreen damage**

Experience of windscreen damage was reported by two-thirds of the respondents (24/36). Chipped glass was the most commonly reported damage (19/36) with 5 drivers reporting larger cracks or shattering. The cause of the damage was mainly from road chippings or stones being thrown up by other vehicles (21/36) and also debris fallen from lorries (3/36). The damage was reported to be more often on the driver's side (13/36) than on the passenger side (3/36).

Of the 36 respondents, 6 had experienced problems with vision while driving at some stage in their driving experience which was believed to be caused by windscreen damage, but never very often. The type of conditions these problems were experienced under included wet conditions, dirty windscreen, sunny weather, dusk and viewing oncoming headlights. The problems associated with driving were rated as being either slight or somewhat but never severe. Problems with windscreen damage were reduced by 3 respondents, by either cleaning their windscreen regularly, getting the windscreen repaired or purchasing a new car.

#### **5.2.5 Windscreen repair**

Only 4 of the 36 drivers reported driving with a damaged windscreen that had been repaired. The repairs were on windscreen chips located on the driver's side. Two respondents had at some point experienced problems due to the repaired windscreen, these occurring in winter when light levels were low (i.e. dusk and dawn) and when very sunny, causing a distraction to the driver. When asked how severe the problem was, the same two respondents found the problem to be slight. One found a way to reduce the vision problems associated with a repaired windscreen was to keep the windscreen clean.

#### **5.2.6 Windscreen reflection**

Of the 36 respondents, 26 had at some time experienced problems due to reflection on windscreens, of which just under half (16/36) had experienced them at least sometimes. The time of day these problems were experienced the most was during the day (19/36), including dusk and dawn (4/36). Problems at night were reported by nearly ¼ of

respondents (8/36). Of the 19 respondents who had experienced visual difficulties with reflection during the day, 18 reported the weather conditions to be sunny and/or clear. A further 6 drivers had difficulties with reflection under wet weather conditions. Other contributors to windscreen reflection were stated as: the dashboard/objects on dashboard and trees (8/36), driving towards a low or bright sun (10/36), oncoming lights (i.e. vehicle and street lights, 5/36), an unclean or smudged screen (3/36) and windscreen angle (1/36).

When asked how severe these visual difficulties with reflection were, 1 driver reported not at all, 15 that the problems were slight, and 10 that the problems to be either somewhat or very severe. A reduction in the visual problems associated with reflection was achieved by 14 of the drivers. The most popular methods used were by wearing sunglasses (5 drivers), by using the sun visor (4) and by removing objects from the dashboard (4).

### **5.2.7 Sun glare**

Problems associated with bright sunlight while driving were experienced often or sometimes by 20/29 drivers, with 4 stating this was often a problem. However only 1 driver reported ever having had an accident or near miss due to this (when reversing out of their drive).

Remedial actions drivers take include using the cars' sun visors (16) and/or wearing sunglasses (10).

### **5.2.8 Tinted windows**

None of the respondents had had their windows tinted and of the eight who stated they had tinted windows they were all an OE light tint. Only one driver claimed that the tint influenced their purchase decision when buying the car, stating that as well as reducing glare it gave a degree of privacy.

If cost is ignored, 13/20 drivers said they would have tinted windows. For 9 of them this would include the windscreen, so as to reduce glare.

### **5.2.9 A-pillar obscuration**

The ages of the cars in this small sample means that many of the respondents cars will not have the newer design of A-pillar, which tends to be thicker and more raked. This limits the extent to which conclusions can be drawn from this part of the survey.

11/29 drivers said that the A-pillar sometimes or often restricts their vision out of the car and 14 stated that they sometimes or often had to move their head to see round it.

In order to assess whether drivers perceive the trend for increased thicknesses and rakes of A-pillar as detrimental to vision, they were asked how the pillar on their current car compared with other cars they had driven. 10 stated it was the same, 8 that it was better and 5 that it was worse.

Two drivers reported near misses that they had experienced as a result of A-pillar obscuration. One had had several near misses at T-junctions in several cars and the other had failed to see an approaching car at a roundabout.

### **5.2.10 Summary of drivers views**

Of the aspects of driver vision mentioned in the remit of this project, problems with glare (which it has been suggested may be addressed by transmission levels) were found to be the most extensive. However drivers in this survey did not experience a significant problem with sun glare, which would motivate them to seek tinted windows.

The accumulation of road film on the interior of the windscreen (contamination) was the next most common cause of visual problems to drivers. The drivers interviewed did not clean their screens on a regular basis and this could have implications for the frequency of misting and 'haze'.

Abrasion and damage caused similar degrees of visual problems, rated as slight or somewhat problematic, with screen repairs causing the least.

The information given above concerning the frequency of occurrence of the visual problem for drivers and the extent to which guidelines exist to advise drivers of unsafe levels was used to prioritise the issues addressed by the test programme.

### 5.3 Survey of motorcyclists' views regarding quality of vision

#### 5.3.1 Trends in motorcycle ownership

In 1997 there were 626,000 licensed motorcycles in the UK, compared to 978,000 in 1987 (Transport Statistics Great Britain 1998). Over this ten-year period there has been a significant change in the types of machine owned. In 1987, two-thirds of licensed machines were under 125cc, in 1997 nearly two-thirds were over 125cc, with the largest single category being machines over 500cc indicating a dramatic shift in the composition of the motorcycle population. Refer to Table 10.

**Table 10: Licensed motorcycles**

| Over             | Not over | 1987      | 1997 |
|------------------|----------|-----------|------|
|                  | 50cc     | 352       | 96   |
| 50cc             | 125cc    | 347       | 143  |
| 125cc            | 150cc    | 4         | 1    |
| 150cc            | 200cc    | 39        | 12   |
| 200cc            | 250cc    | 78        | 44   |
| 250cc            | 350cc    | 13        | 10   |
| 350cc            | 500cc    | 46        | 54   |
| 500cc            |          | 99        | 265  |
| All over 50cc    |          | 626       | 530  |
| All engine sizes |          | 978       | 626  |
|                  |          | thousands |      |

We can speculate on the possible reasons for this shift in ownership; changes in the motorcycle driving test, fewer people using a motorcycle to commute to work and an increase in the number of older riders returning to motorcycling. The shift to larger machines may contribute to an increased market for tinted visors. The riders of more powerful and faster machines may have more disposable income, seek more ways of increasing their perceived safety and given the high-tech nature of modern motorcycling may seek out the latest technology in their protective equipment.

To help ensure that the scope of the testing programme addressed all the key issues, a survey was undertaken to seek riders views on the quality of vision through motorcyclists' eye protection systems. In order to obtain first-hand information about the perceived visual performance of the eye protection options currently available to motorcyclists, a small survey was undertaken of professional and non-professional riders.

Completed questionnaires were obtained from 28 members of the public (25 male, 3 female) and 14 professional riders (all male). Sample details are given in the tables below. Full survey details are given in Appendix 6a.

**Table 11: Age and years of riding**

|         | General public |              | Professional |              |
|---------|----------------|--------------|--------------|--------------|
|         | Age            | Years riding | Age          | Years riding |
| Average | 41             | 15           | 39           | 20           |
| Minimum | 22             | 1            | 32           | 15           |
| maximum | 73             | 44           | 53           | 25           |

**Table12: Size of motorcycles ridden**

|              | General public | Professional |
|--------------|----------------|--------------|
| Up to 250cc  | 3              | 0            |
| 260 – 500cc  | 7              | 0            |
| 510 – 1000cc | 16             | 1            |
| Over 1000cc  | 2              | 13           |

**Table 13: Use of motorcycle (multiple responses allowed)**

|              | General public | Professional |
|--------------|----------------|--------------|
| Commuting    | 21             | 7            |
| Professional | 6              | 14           |
| Leisure      | 34             | 14           |

**Table 14: Frequency of riding**

|         | General public | Professional |
|---------|----------------|--------------|
| Daily   | 13             | 13           |
| Weekly  | 11             | 0            |
| Monthly | 4              | 1            |

All the riders in the sample used visors and full faced helmets.

Having asked the riders how frequently they rode in different weather conditions they were asked an open question for any comments with a prompt for vision problems.

The main problems raised were:-

- *Misting* (5/14 professional, 3/28 public): particularly when riding slowly.
- *Rain* (5/14 professional, 1/28 public): water droplets on the visor, which caused light scatter and multiple images of car headlamps.
- *Glare* (in bright sunlight) (3/14 professional, 3/28 public).
- *Abrasion* problems were not spontaneously mentioned by any of the riders.

### 5.3.2 Misting

When asked specifically about misting most of the professional riders claimed that their visors suffered from it 'sometimes' or 'often' (13/14). A lower proportion of general riders suffered this problem (12/28) however this may reflect how often riders reported riding in the rain (13/14 professionals 'often' ride in the rain compared to 12/28 general riders).

Misting was reported as being a particular problem at slow speeds, where air circulation through the helmet is insufficient to clear the visor.

### 5.3.3 Glare

Sun glare was reported as a problem by a high proportion of both professional (11/14) and general (19/28) riders. Whilst the main problem for both groups occurs when the sun is low in the sky, the professionals also reported problems during bright sunlight when the road surface is wet.

Confirming the glare problem, 24/28 public and 11/14 professional riders stated that some form of glare reducing eye protection would be useful in conditions of low sun or bright sunlight.

With respect to tinted visors 12/28 of the general public and 1/14 of the professional riders stated that their visor was tinted (and at least one of these was used for racing). The range of tinted visors used reflects the current market and includes blue iridescent, gold, black, mirror finish etc). From the responses it would appear that 5/28 members of the general public and 0/14 for the professional riders have visors with luminance transmissions below the current required minimum.

Half of the riders in the sample have ridden with tinted visors at night time or in conditions of poor visibility (14/28 general public and 6/14 professional)

It is interesting to note that while only 1/14 professional riders is currently using a tinted visor, 8/14 have tried one at some time. The most frequent reason (and reported benefit) being to reduce glare. Seven of these eight riders reported the main disadvantage as being the reduced visibility at lower light levels (dusk, overcast sky and night time). Of all the riders, ten stated that the visor reduced their ability to see under these conditions. A further 2 stated that they adjusted their riding accordingly so it must be assumed that their vision was also reduced.

#### **5.3.4 Changing from tinted to clear visors when visibility declines**

Two issues raised by this option were addressed in the survey: how easy is it to change a visor and would riders be prepared to do it?

18/28 general public riders stated that they would be prepared to use tinted visors in bright daylight and change to clear when visibility was poor and at night time. A high proportion (11/14) of professional riders would accept this option, which may result from them having to ride in almost all weather conditions. However given that half of the sample have admitted to using visors illegally, these statements should be treated with caution.

It would appear that physically changing the visor is not generally a problem, with 34/38 riders who had ever changed their visor stating that the ease with which they could do it was at least 'acceptable'.

### **5.3.5 Alternatives to tinted visors**

Nearly all the riders had used sunglasses as a means of reducing sun glare while riding (36/42). Three had used helmet peaks and only one had tried a sun-strip.

The one benefit of using sunglasses as a means of glare reduction, reported by several riders in the survey, was the ability to put them on or take them off according to conditions.

The most frequent problem cited was the discomfort of wearing sunglasses under some helmets.

### **5.3.6 Abrasion**

The riders did not appear to consider abrasion a significant problem with their visors. 13/14 professional riders and 19/28 of the general riders stated that scratches were 'rarely' or 'never' a problem. Given the average age of their visors (21 months) this must reflect upon the good abrasion qualities of the coatings used on current visors and the effectiveness of the current standard.

However it may be worth considering that as most abrasion will be the result of repeated cleaning and the effects of air borne abrasives, it is likely that riders will adapt to a degree of abrasion and may therefore be unaware of some degree of reduced vision.

### **5.3.7 Summary of riders' views**

The high levels of abrasion resistance of modern materials means that scratched visors are no longer a significant problem for riders.

Misting however is a problem, especially when travelling at slow speeds.

Sun-glare, either direct when the sun is low in the sky, or when reflected off wet road surfaces is a significant problem. Some riders have used tinted visors in these conditions. However, they report that when doing so their vision under low light levels is reduced.



Sunglasses are a partial solution to the problem but can be uncomfortable when worn under a helmet.

#### **5.4 Survey of visor usage**

Sales figures give an indication of the numbers of different types of visor in use and the demand for tinting. Bob Heath supplied figures for their popular 2mm replacement visors over the last 8 years – 61% clear, 39% smoke (all BS4110ZA certified).

##### **5.4.1 ICE Ergonomics survey**

A survey of 100 motorcyclists was undertaken by ICE Ergonomics to investigate the extent of visor misuse. The transmission level of each visor was measured using the Tintman – vehicle window transmission meter, a technical instrument used by a number of police forces to measure window and visor transmission levels. Refer to Appendix 6b.

With respect to the transmission levels, the survey findings were that:

- 80% of visors had transmission levels above 80%.
- 9% had transmission levels between 50% and 80% (daytime use only level)
- 11% had transmission levels below 50% (below permitted transmission levels).

Indirect questions were asked to determine if the visor would be used after dusk on the night of the survey. Of the 20 respondents whose visor transmission levels were below 80% i.e. below the level currently regulated as being suitable for use in conditions of low light, all stated that they would be riding home at dusk or later. Only one respondent who had a daytime usage visor carried a spare; however this was also a daytime use only visor.

It can therefore be concluded that from the sample of 100 motorcyclists, there was a 20% misuse rate comprising of 9% who would use daytime visors in inappropriate conditions and 11% whose visors were less than the currently regulated daytime levels.

In addition it was found that:

- of those 31 riders who often ride in the dark, 9 had visors of inappropriate transmission levels,
- of those 48 riders who sometimes ride in the dark, 7 had visors of inappropriate transmission levels.

Refer to the tables below for additional information.

**Table 15: Visor age and miles travelled**

|                       | Mean | Min  | Max   | SD   |
|-----------------------|------|------|-------|------|
| Age of visor in years | 1.59 | 0.02 | 8.00  | 1.62 |
| Miles per year        | 6255 | 1000 | 15000 | 2656 |

**Table 16: Frequency of riding in various conditions**

|          | Often | Sometimes | Rarely | Never |
|----------|-------|-----------|--------|-------|
| Rain     | 26    | 52        | 17     | 5     |
| Darkness | 31*   | 48**      | 17     | 4     |
| Sunlight | 92    | 8         | 0      | 0     |
| Fog/mist | 7     | 35        | 49     | 9     |

\* Of the 31 respondents who often ride in darkness, 9 had visors of inappropriate transmission levels.

\*\* Of the 48 respondents who sometimes ride in darkness, 7 had visors of inappropriate transmission levels

#### 5.4.2 Surveys by other organisations

A survey was undertaken by the Transport Research Laboratory the results of which are given in Appendix 3. These results compare favourably with those found from the survey of motorcyclists views reported above.

Raw data from surveys undertaken by a police force in which visors being used on the road were measured using 'Tintman' are given below. The table shows that illegal visors, in terms of their luminous transmission values, can be obtained and used on the roads.

**Table 17: Luminous transmission values for South Yorkshire police visor surveys**

| <b>Manufacturer</b> | <b>Comment</b>              | <b>Grade</b> | <b>Tintman reading %<br/>(taken at visor centre)</b> |
|---------------------|-----------------------------|--------------|--|
| AGV                 |                             | Smoke        | 21.3   |
| Arai                |                             | Clear        | 88.0   |
| Arai                |                             | Dark         | 21.3   |
| Arai                |                             | Iridium      | 16.7   |
| Arai                | Kite mark                   | Smoke        | 57.0   |
| BMW System4         | Daytime use                 | Dark         | 15.0   |
| Bob Heath           | Daytime use                 | Smoke        | 50.0   |
| Nolan Xlite         | No marks                    | Dark         | 14.5   |
| Nolan Xlite         |                             | Iridium      | 30.1   |
| Roof                | Boxer                       | Dark         | 16.2   |
| Roof                | Roadster                    | Dark         | 19.2   |
| Shark               |                             | Dark         | 13.1   |
| Shoei CX1           |                             | Dark         | 20.0   |
| Shoei CX1           |                             | Iridium      | 28.0   |
| Shoei CX1           |                             | Yellow       | 46.2   |
| Shoei CX1           |                             | Smoke        | 57.0   |
| Suomy               | Fitted with clear fog visor | Dark         | 13.5   |
| Suomy               |                             | Iridium      | 11.4   |

### 5.5 Summary of visor usage surveys

The data obtained from the visor usage surveys by both ICE Ergonomics and the police force indicate that illegal visors can be obtained for use on the road. In addition ICE's work further indicates that illegal visors (those with a luminous transmission of less than 50%) and those for daytime use only (those with a luminous transmission between 50-80%) will be used inappropriately in conditions of reduced ambient lighting.

## 6.0 Luminous transmission trials – Initial laboratory study

The aim of these trials was to investigate the relationship between the level of luminous transmission and the ability to detect objects in the road under conditions of:

- bright daylight,
- bright daylight with target objects in shadow,
- cloudy/overcast day,
- low sun,
- dawn/dusk/twilight,
- night-time with streetlights (dry),
- night-time with streetlights (wet),
- night-time without streetlights.

This was undertaken with a view to optimise driver/rider performance for each condition and across all conditions.

In order to investigate the effect of decreasing luminous transmission (darker tints), on drivers'/riders' ability to detect target objects in a road scene, a series of trials were conducted on the model road facility at ICE Ergonomics and these are described below.

### 6.1. The model road

The model road consists of a light proof box 8m long by 1.25m wide with a 1:20 scale road modelled inside. The road's surface reflectivity characteristics and macro texture are modelled on black asphalt ( $Q_0 0.07$ ). The top surface of the box has seven apertures over which streetlights are placed to allow light to fall onto the road's surface in a manner representative of night-time streetlighting.

Adjusting the size of the aperture controls the level of illumination, whilst polished aluminium baffles are used to control the uniformity of the light.

Through combinations of different lighting, a range of daytime lighting conditions can also be simulated.

The model road scene is viewed through a shutter mechanism that can be adjusted to give the observer varying glimpse durations of the road scene. Exposure times of 200 milliseconds are typically used for experiments investigating static, small target visibility because they represent a realistically arduous condition in visual search and detection behaviour. Whilst scanning a scene, rapid saccadic eye movements result in changes of fixation which are typically 200 milliseconds in duration. Each fixation brings the retinal image of an object being viewed onto the fovea where there is high spatial resolution.

The observer's viewing position in the model is equivalent to 1.5m above the road's surface and gives a realistic drivers' eye view of the scene. Refer to Figures 1 and 2.



**Figure 1: Observers view of model road**



**Figure 2: Model road facility**

(The side of the model is shown removed for the purposes of the photograph)

## 6.2. Test Variables

### 6.2.1. Target Objects

The target objects presented in the road scene were a 1:20 scale adult male pedestrian of 95<sup>th</sup> %ile height and a scaled 20cm flat disc, each with a uniform 20% reflectivity.

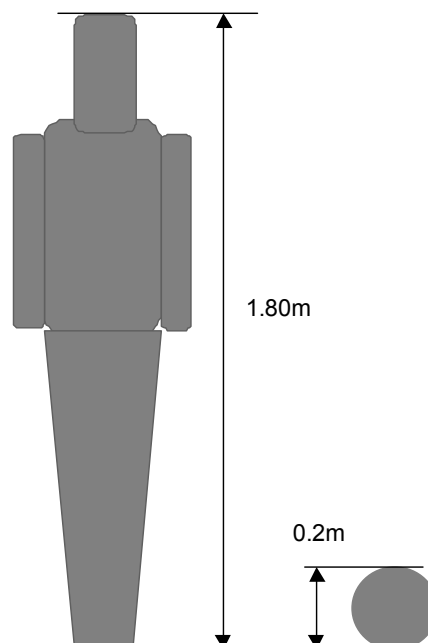

**Figure 3: Target objects**

### 6.2.2. Test Materials

Targets were viewed through materials with different luminous transmission properties. A description of each material, its luminous transmission and the rationale for selection are shown in Table 18.

**Table 18: Test material's description and specification**

| <b>Material</b>   | <b>L.T.</b> | <b>Rationale</b>  |
|---|-------------|---|
| Laminated glass windscreen - with clear interlayer  | 82%         | Windscreens must have a luminous transmittance > 75% (ECE Reg. No. 43) and motorcycle crash helmet visors >80% (ECE Reg. No. 22.05 and BS6658)  |
| Toughened glass side window -   | 74.5%       | Automotive glazing, other than windscreens must have luminous transmittance >70% (ECE Reg. No. 43)  |
| Lexon coated thin gauge polycarbonate motor cycle crash helmet visor                            | 51%         | Motorcycle crash helmet visors may have a luminous transmittance $\geq$ 50% if marked "Daytime use only" (ECE Reg. No. 22.05 and BS6658)  |
| Toughened glass side window (Pilkington Optikool) with a <i>light smoke</i> tint film applied.  | 45.3%       | Goggles with filter category 12 or sunglasses with filter category 1 (light tint) shall have luminous transmittance >43% - defined 'suitable for driving' by BS EN 1938 and 1836 respectively   |
| Toughened glass side window (Pilkington Optikool) with a <i>smoke bronze</i> tint film applied. | 33.4%       | Many worldwide regulatory authorities accept down to 35% luminous transmission for side and rear windows. These include South Africa, some states in USA and Australia.   |
| Toughened glass side window (Pilkington Optikool) with a <i>midnight</i> tint film applied.     | 19.6%       | Most members of the BS visor committee support a reduction in the minimum light transmission of visors to $\geq$ 18%. Some research evidence was found which was also supportive of this. Refer to section 2.1.3 It appears from the research and standards that the minimum light transmission which should be considered for drivers and riders is 18%, although this seems to be in conflict with BSEN1836 (sunglasses – see section 2.1.3). |

### 6.2.3. Ambient Light Levels

Eight ambient lighting conditions were replicated in the model road. These are described in Table 19.

**Table 19: Model road ambient lighting conditions**

| Lighting Condition   | Max & Mean Luminance in the vicinity of the target (cd/m <sup>2</sup> ) |
|--|---|
| Bright daylight  | 4661 442  |
| The bright daylight condition is that under which motorcyclists wish to be granted permission to wear eye protection with luminous transmission properties as low as 18%.                |   |
| Bright daylight with target objects in shadow  | 1400 392  |
| This lighting condition may be encountered in a road scenario where a driver/rider, whose eyes are adapted to bright daylight conditions, is approaching an area of road in dark shadow. |   |
| Cloudy/Overcast day  | 1143 226  |
| A lighting condition which could be encountered by a motorcyclist or driver who began a journey in bright daylight.  |   |
| Low sun (high luminance glare source in drivers'/riders' field of vision).   | 90600 3017  |
| Another lighting condition where motorcyclists wish to use eye protection with low luminous transmission.  |   |
| Dawn/Dusk/Twilight   | 7.48 1.34   |
| A lighting condition which is likely to be encountered by a motorcyclist or driver who began a long journey in bright daylight.  |   |
| Night time with street lights and headlamps on - dry road.   | 6.47 0.98   |
| A lighting condition under which heavily tinted visors and windscreens may be misused.   |   |
| Night time with street lights and headlamps on - wet road.   | 3.53 0.82   |
| A lighting condition under which heavily tinted visors and windscreens may be misused.   |   |
| Night time, unlit road, headlamps on.  | 0.64 0.11   |
| A lighting condition under which heavily tinted visors and windscreens may be misused.   |   |

### 6.2.4. Trial Participants

Twenty, current UK driving licence holding participants (7 male and 13 female) whose ages ranged from 18 to 75 years (mean age 44 years, SD 16.3) were recruited from ICE's database.



### **6.3. Test methodology**

For each ambient lighting condition, each participant viewed the road scene through each test material for a duration of 200ms. Pedestrian or disc targets were presented at one of six positions in the road scene corresponding to left kerb, right kerb or road centre at 23m or 73m distance from the participant. These distances equate to an approximate stopping distance i.e. thinking and braking distance, for a vehicle travelling at 30mph and 60mph respectively. Pre-trial testing indicated that it was only necessary to assess the pedestrian target at 73m since it could be consistently accurately detected at 23m. The participants were required to indicate whether a target was present in the road scene and in order to detect a participant's willingness to guess at a target's presence, for each condition 50% of the road scene exposures had no target present.

### **6.4. Bright daylight**

#### **6.4.1. Methodology**

Under the 'bright day' ambient lighting condition, each participant was presented with a disc target twice at each distance - 23m and 73m - viewed through each of the test materials. One disc presentation was at the road centre position the other was either left kerb or right kerb. Pre-trial testing indicated that it was not necessary to assess the pedestrian target in this condition since it could be consistently accurately detected at 73m.

#### **6.4.2. Results/Findings**

Figure 4 illustrates the effect of a material's luminous transmission on participants' ability to detect centre and off-centre disc targets at 23m and 73m under bright ambient lighting conditions.

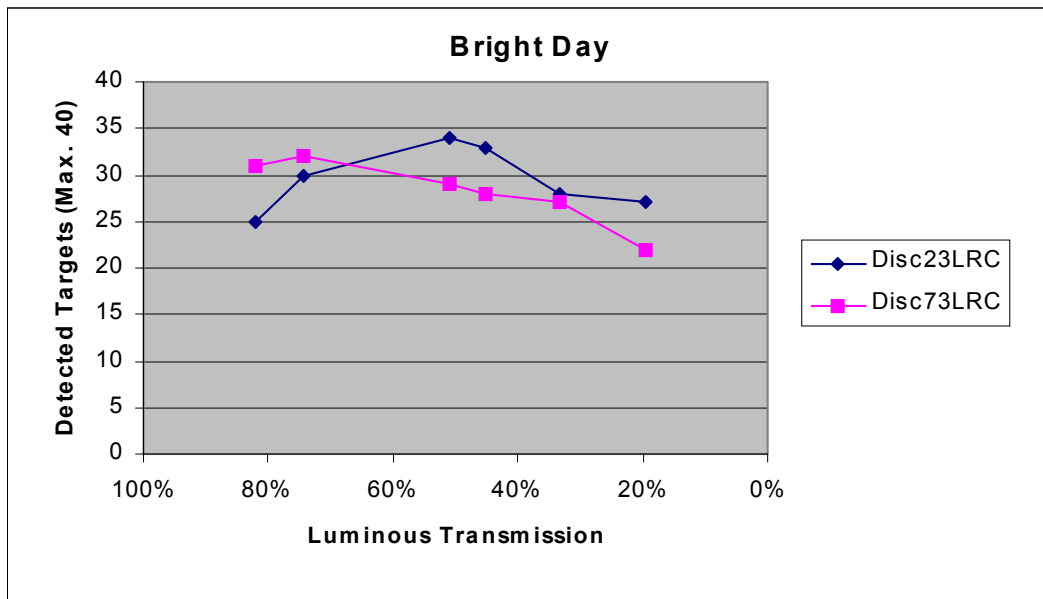

**Figure 4: Target detection under bright, daytime conditions**

#### 6.4.3. Conclusions

Although the graph appears to indicate that disc targets at 23m are easier to see when viewed through materials with luminous transmission of approximately 50% and disc targets at 73m are more difficult to see as luminous transmission reduces, these are not statistically significant.<sup>1</sup> The trends seen are due to random variation and luminous transmission does not affect target detection under bright daylight conditions.

### 6.5. Bright daylight with target objects in shadow

#### 6.5.1. Methodology

Under the 'bright daylight with target in shadow' ambient lighting condition, each participant was presented with a disc target twice at each distance - 23m and 73m - and viewed through each of the test materials. One disc presentation was at the road centre position the other was either left kerb or right kerb.

<sup>1</sup> All data was tested for statistical significance using a two-tailed, paired t-test at 5% significance. Any apparent differences between conditions which are not significant are due to natural variability in the data and are not due to transmission level.

Additionally, a pedestrian target was presented twice at the 73m distance, one presentation at the road centre position the other at either left kerb or right kerb.

### 6.5.2. Results/Findings

Figure 5 illustrates the effect of a material's luminous transmission on participants' ability to detect disc targets at 23m and 73m and pedestrian targets at 73m under bright ambient lighting conditions with the target objects in shadow.

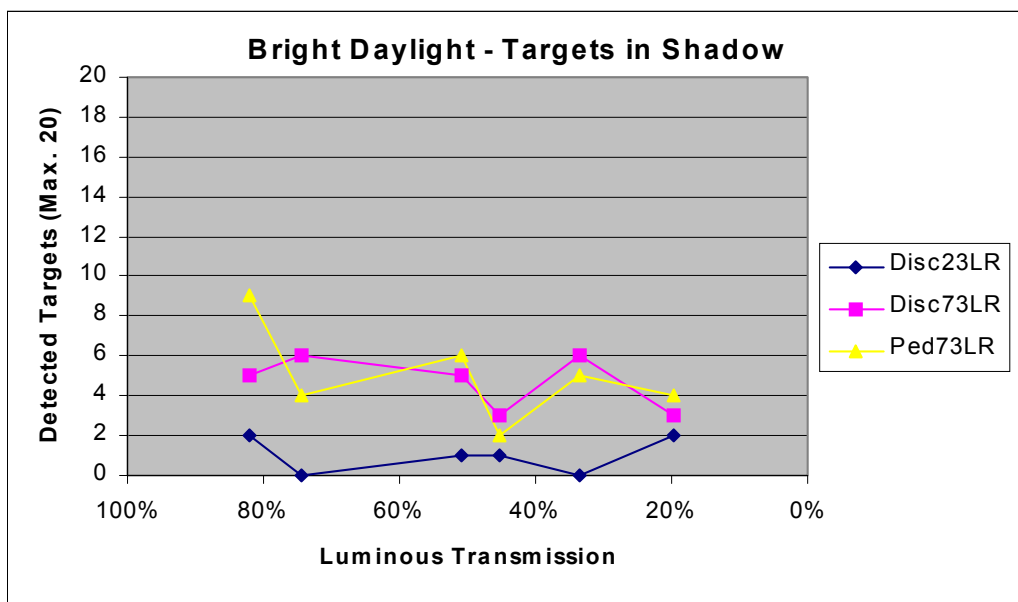

**Figure 5: Target detection under bright, daytime conditions with targets in shadow**

The maximum target detections for this condition are 20 since only the off-centre targets represented the worst case scenario for this condition of low contrast between the target and its background as well as high levels of ambient illumination.

### 6.5.3. Conclusions

Figure 5 shows that, as a proportion, the number of targets detected has reduced compared to the previous condition of bright daylight. This is to be expected since the low contrast of the target against its background, caused by the effects of shadows, increases the difficulty of the detection task.

Statistical analysis indicates that there is no significant difference across the different levels of luminous transmission for all of the targets i.e. the peaks and troughs shown in figure 5 are due to random variation and luminous transmission does not affect detection.

In addition there is no statistical difference between the targets across the different levels of luminous transmission i.e. the disc at 23m is not more difficult to detect than the disc or pedestrian at 73m.

## **6.6. Cloudy, overcast day**

### **6.6.1. Methodology**

Under the 'cloudy, overcast day' ambient lighting condition, each participant was presented with a disc target twice at each distance - 23m and 73m - and viewed through each of the test materials. One disc presentation was at the road centre position the other was either left kerb or right kerb. Pre-trial testing indicated that it was not necessary to assess the pedestrian target since it could be consistently accurately detected at 73m.

### **6.6.2. Results/Findings**

Figure 6 illustrates the effect of a material's luminous transmission on participants' ability to detect centre and off-centre disc targets at 23m and 73m under cloudy overcast lighting conditions.

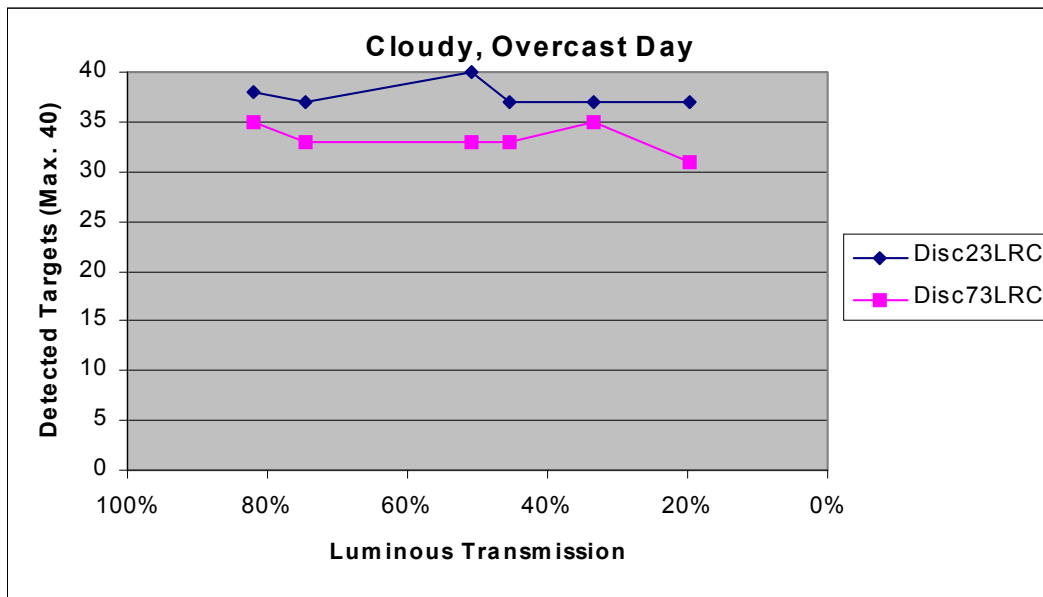

**Figure 6: Target detection under cloudy, overcast conditions**

### 6.6.3. Conclusions

This condition suggests an improvement in the detection rates for discs at both 23m and 73m over previous conditions although this is not statistically significant over the whole data range. The greater contrast of the targets against their background compared to condition 2 (bright day with targets in shadow) facilitates their detection whilst the reduction in ambient lighting compared to condition 1 (bright daylight) also assists detection.

Statistical analysis indicates that for disc targets at both distances there is no significant difference in their detection rates across the different levels of luminous transmission. The graph above therefore depicts random variation and luminous transmission does not affect target detection.

## 6.7. Low sun condition

### 6.7.1. Methodology

Under the 'low sun' ambient lighting condition, each participant was presented with a disc target twice at each distance - 23m and 73m - and viewed through each

of the test materials. One disc presentation was at the road centre position the other was either left kerb or right kerb. Additionally, a pedestrian target was presented twice at the 73m distance, one presentation at the road centre position the other at either left kerb or right kerb.

### 6.7.2. Results/Findings

Figure 7 illustrates the effect of a material's luminous transmission on participants' ability to detect centre and off-centre disc targets at 23m and 73m under low sun ambient lighting conditions.

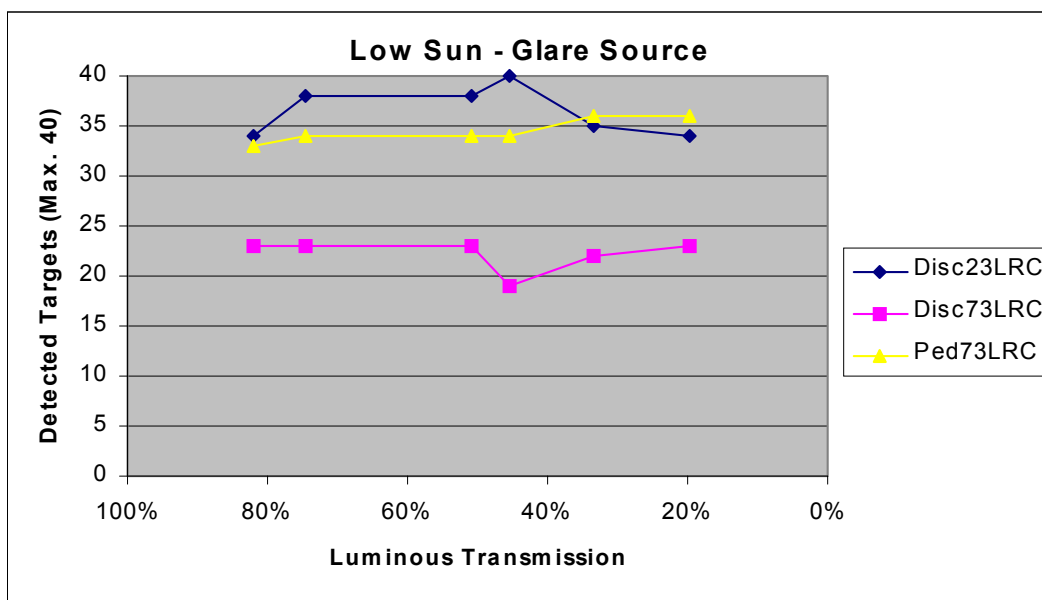

**Figure 7: Target detection under cloudy, overcast conditions**

### 6.7.3. Conclusions

Statistical analysis indicates that there is no significant difference across the different levels of luminous transmission for all of the targets i.e. the peaks and troughs shown in Figure 7 are not significant and luminous transmission does not affect detection.

Comparing the data in Figure 7 with that in Figure 6, it can be seen that sun glare reduces the visibility of the small disc target at the longer viewing distance of 73m. However Figure 7 shows that tinting does not assist with this problem.

## 6.8. Dawn/Dusk conditions

### 6.8.1. Methodology

Under the 'dawn/dusk' ambient lighting condition, each participant was presented with a disc target twice at each distance - 23m and 73m - and viewed through each of the test materials. One disc presentation was at the road centre position the other was either left kerb or right kerb. Additionally, a pedestrian target was presented twice at the 73m distance, one presentation at the road centre position the other at either left kerb or right kerb.

### 6.8.2. Results/Findings

Figure 8 illustrates the effect of a material's luminous transmission on participants' ability to detect centre and off-centre disc targets at 23m and 73m under 'dawn/dusk' ambient lighting conditions.

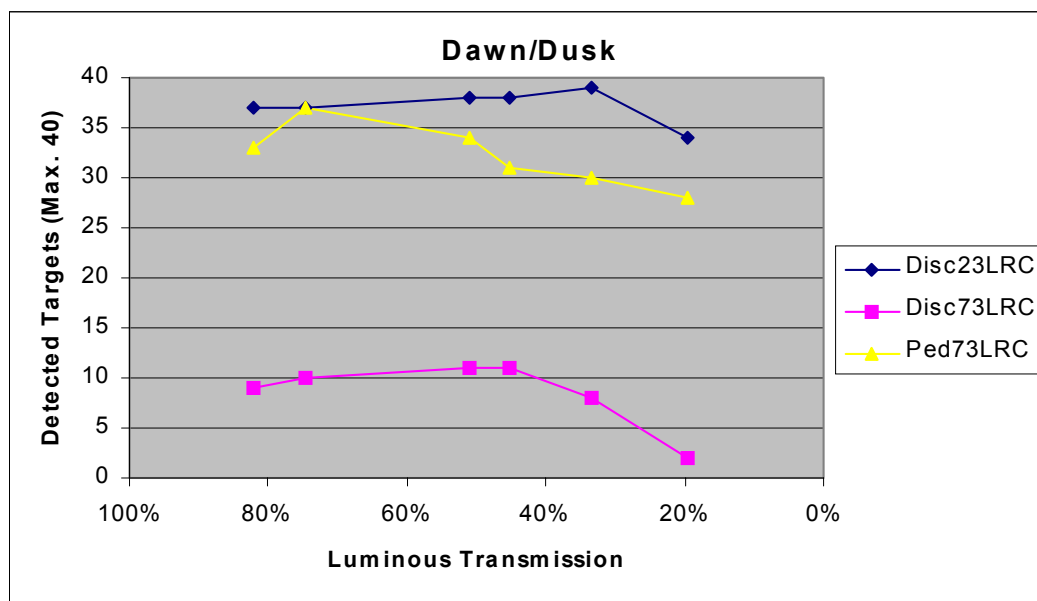

**Figure 8: Target detection under dawn/dusk conditions**

### 6.8.3. Conclusions

With respect to the disc targets at both 23m and 73m, there was no statistically significant difference in their detection rates across the different levels of luminous transmission i.e. luminous transmission did not affect target detection. However analysis of the pedestrian data indicated a significant decrease in pedestrian detections between luminous transmissions of 74.5% and 19.6%. No

significant effects were observed between other levels of luminous transmission. It may appear curious that luminous transmission appears only to affect the larger pedestrian target and not the smaller disc target when viewed at 73m. An explanation for this is that the smaller disc target is too small to be clearly seen and detection rates are only likely to be significantly improved by increasing the ambient illumination. The pedestrian target is sufficiently large to have improved detection rates over the disc but these are eroded by the reduced contrast of the pedestrian with its background when viewed through materials with reduced luminous transmission. Hence as luminous transmission reduces, the rate of pedestrian detection falls as shown by the graph.

The reduced detection rate for disc targets at 73m across all levels of luminous transmission is statistically significant compared to the disc target at 23m and pedestrian target at 73m.

## **6.9. Night time with street lights and headlamps - dry road.**

### **6.9.1. Methodology**

Under the 'night time with street lights and headlamps - dry road' ambient lighting condition, each participant was presented with a disc target twice at each distance - 23m and 73m - and viewed through each of the test materials. One disc presentation was at the road centre position the other was either left kerb or right kerb. Additionally, a pedestrian target was presented twice at the 73m distance, one presentation at the road centre position the other at either left kerb or right kerb.

### **6.9.2. Results/Findings**

Figure 9 illustrates the effect of a material's luminous transmission on participants' ability to detect centre and off-centre disc targets at 23m and 73m under 'night time with street lights and headlamps - dry road' ambient lighting conditions.



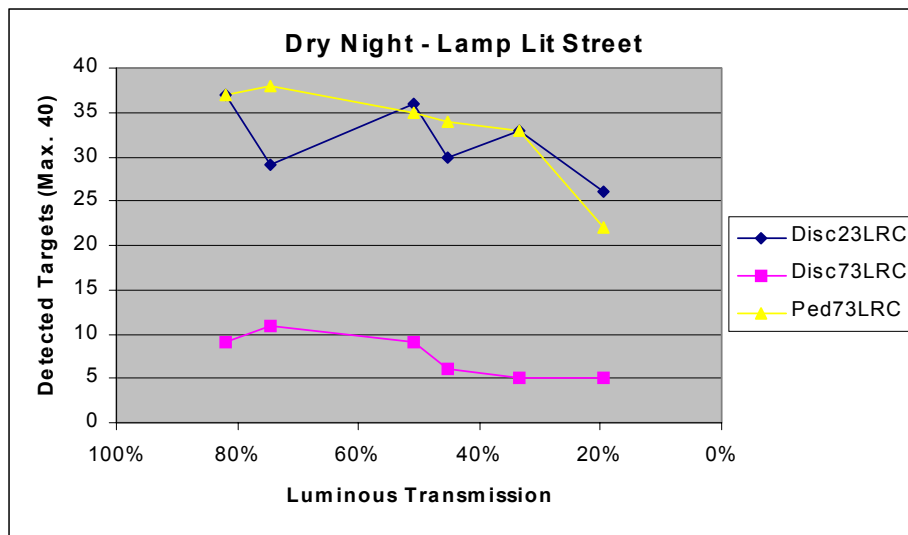

**Figure 9: Target detection under dry, night-time conditions with street lights and headlamps**

### 6.9.3. Conclusions

With respect to the disc targets at both 23m and 73m, there was no statistically significant difference in their detection rates across the different levels of luminous transmission i.e. luminous transmission did not affect target detection. However analysis of the pedestrian data indicated a significant decrease in pedestrian detections between luminous transmissions of 74.5% and 19.6%. The rationale for the larger pedestrian target being affected by reducing levels of luminous transmission and not the smaller disc target when both are viewed at 73m is given in section 6.8.3.

The reduced detection rate for disc targets at 73m across all levels of luminous transmission is statistically significant compared to the disc target at 23m and pedestrian target at 73m.

## 6.10. Night time with street lights and headlamps - wet road

### 6.10.1. Methodology

Under the 'night time with street lights and headlamps - wet road' ambient lighting condition, each participant was presented with a disc target twice at each distance

- 23m and 73m - and viewed through each of the test materials. One disc presentation was at the road centre position the other was either left kerb or right kerb. Additionally, a pedestrian target was presented twice at the 73m distance, one presentation at the road centre position the other at either left kerb or right kerb.

### 6.10.2. Results/Findings

Figure 10 illustrates the effect of a material's luminous transmission on participants' ability to detect centre and off-centre disc targets at 23m and 73m under 'night time with street lights and headlamps - wet road' ambient lighting conditions.

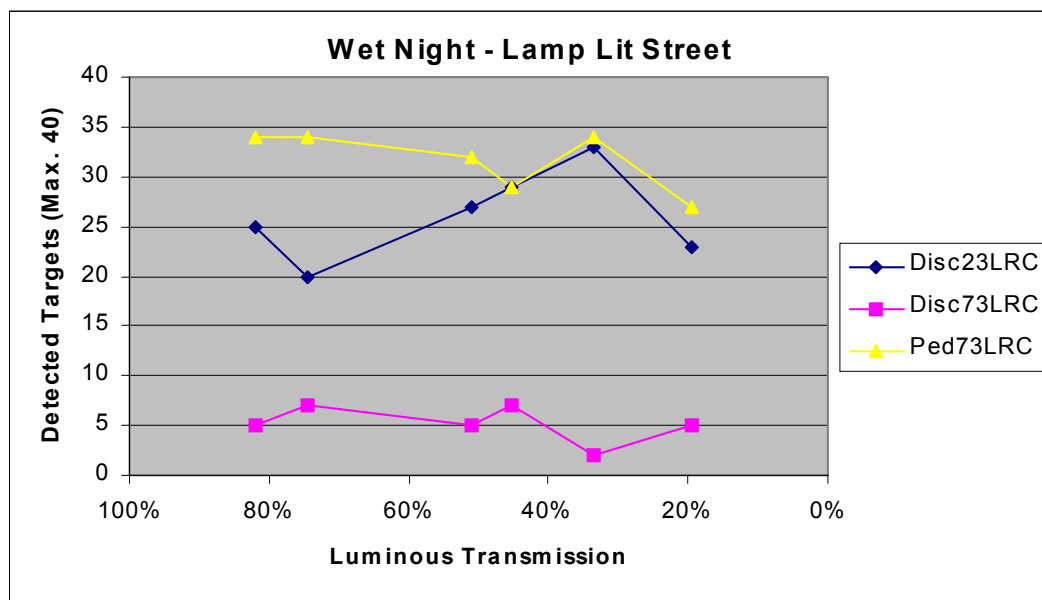

**Figure 10: Target detection under wet, night-time conditions with street lights and headlamps**

### 6.10.3. Conclusions

With respect to the disc at 73m and the pedestrian at 73m there was no statistically significant difference in the detection of these targets across the various levels of luminous transmission i.e. luminous transmission did not affect detection.

Significant differences found for the disc target at 23m with respect to the material with 33.4% luminous transmission were further investigated and were found to be

due to procedural issues in the experimental design rather than a true result. Analysis of the raw data suggested that disc targets at 23m were likely to be seen more easily under this particular test condition, whilst the same targets viewed under the material of 74.5% luminous transmission were likely to have been more difficult to see. If allowances were made to compensate for this the graphical line for disc target at 23m shown in Figure 10 would become flatter suggesting that luminous transmission is less likely to have an effect on detection.

The reduced detection rate for disc targets at 73m across all levels of luminous transmission is statistically significant compared to the disc target at 23m and pedestrian target at 73m.

## **6.11. Night time with headlamps only - dry road.**

### **6.11.1. Methodology**

Under the 'night time with headlamps only - dry road' ambient lighting condition, each participant was presented with a disc target twice at each distance - 23m and 73m - and viewed through each of the test materials. One disc presentation was at the road centre position the other was either left kerb or right kerb. Additionally, a pedestrian target was presented twice at the 73m distance, one presentation at the road centre position the other at either left kerb or right kerb.

### **6.11.2. Results/Findings**

Figure 11 illustrates the effect of a material's luminous transmission on participants' ability to detect centre and off-centre disc targets at 23m and 73m under 'night time with headlamps only - dry road' ambient lighting conditions.

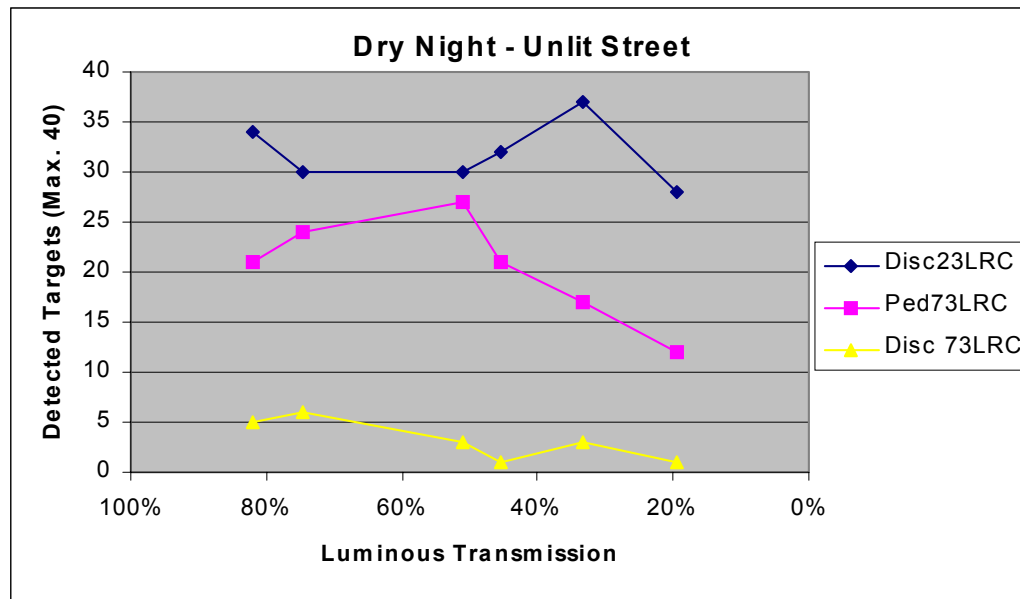

**Figure 11: Target detection under dry, night-time conditions with headlamps only**

### 6.11.3. Conclusions

With respect to the discs at 23m and 73m, there was no statistically significant difference in the detection of these targets across the various levels of luminous transmission i.e. luminous transmission did not affect detection and the peaks and troughs shown are not significant.

A significant difference was found for the pedestrian target at 73m when viewed through a material with a luminous transmission of 51% compared to one of 19.6%. It is likely that this is a feature of the experimental design rather than a true result and the real detection rate is likely to be somewhat lower than that shown. Analysis of the downward sloping curve for luminous transmission levels 74.5%, 45.3%, 33.4% and 19.6% indicates that for every 5% reduction in transmission, approximately one additional pedestrian would not be detected.

The reduced detection rate for disc targets at 73m across all levels of luminous transmission is statistically significant compared to the disc target at 23m and pedestrian target at 73m.

## 6.12. Summary

The results of the bright daylight, bright daylight with target objects in shadow and the low sun conditions indicate that luminous detection did not affect the probability of detection of the disc or pedestrian targets at 23m or 73m. This indicates that there were no detection benefits to the use of dark visors in daytime conditions.

Luminous transmission did not affect the probability of detection of the disc targets at 23m or 73m. Instead the probability of detecting a disc target appears to be more dependent upon the level of ambient lighting. This is indicated by the finding that the disc target at 73m was significantly more difficult to see i.e. had fewer correct detections than the other targets, under the low sun condition and the dawn/dusk and night-time conditions. Under these conditions the detection rate of the disc at 73m was consistently low across all the levels of luminous transmission. This suggests that the smaller disc target was too small to be clearly seen and detection rates are only likely to be significantly improved by increasing the ambient illumination.

The pedestrian target at 73m was significantly more difficult to see under the dawn/dusk and dry, night-time with streetlighting condition when viewed through the materials with 19.6% luminous transmission compared to one with 74.5%. No significant effects were observed between other levels of luminous transmission. (This concurs with previous research which found that tinting can be problematic for low contrast objects under low ambient lighting conditions). Since there was found to be no significant difference in detection between 75% and 33.4% and some significant difference in detection between 75% and 19.6%, the question arises as to what point, between these two levels does the detection of pedestrians just become significant i.e. the threshold between acceptable and unacceptable pedestrian detection rates.

To make this estimate it was necessary to create 'dummy' target detection data for incremental levels of transmission between 33.4% and 19.6%. The data columns would total to the required number of pedestrians detected. Statistical tests could

then be made comparing this theoretical data against the actual data. The number of pedestrians detected, which just reached significance, could then be related to the known data to find the corresponding transmission level.

Care was taken in the creation of the ‘dummy’ data to ensure that the range of responses was similar to the actual data so that variances would be similar.

The tables below show the actual and dummy data and will help the reader comprehend the methodology (see particularly the night-time with streetlights and headlamps condition).

**6.12.1. Dawn/dusk condition**

**Table 20: Significance calculations for dawn/dusk condition**

| Ped 73                      | 82 | 74.5     | 51       | 45.3     | 33.4     | 19.6            |    | dummy data      |
|-----------------------------|----|----------|----------|----------|----------|-----------------|----|-----------------|
| Transmissi                  | A  | B        | C        | D        | E        | F               |    | x1              |
| Subject 1                   | 0  | 0        | 0        | 0        | 0        | 0               |    | 0               |
| Subject 2                   | 2  | 2        | 2        | 1        | 1        | 1               |    | 1               |
| Subject 3                   | 1  | 2        | 2        | 2        | 2        | 1               |    | 2               |
| Subject 4                   | 1  | 1        | 1        | 2        | 0        | 1               |    | 1               |
| Subject 5                   | 2  | 2        | 2        | 2        | 2        | 1               |    | 1               |
| Subject 6                   | 2  | 2        | 2        | 1        | 1        | 1               |    | 1               |
| Subject 7                   | 2  | 2        | 2        | 1        | 1        | 2               |    | 2               |
| Subject 8                   | 2  | 2        | 2        | 2        | 2        | 2               |    | 2               |
| Subject 9                   | 2  | 2        | 1        | 2        | 2        | 1               |    | 1               |
| Subject 10                  | 2  | 2        | 2        | 1        | 1        | 2               |    | 2               |
| Subject 11                  | 2  | 2        | 2        | 2        | 2        | 2               |    | 2               |
| Subject 12                  | 2  | 2        | 2        | 2        | 2        | 2               |    | 2               |
| Subject 13                  | 1  | 2        | 2        | 1        | 2        | 2               |    | 2               |
| Subject 14                  | 2  | 2        | 2        | 2        | 2        | 2               |    | 2               |
| Subject 15                  | 1  | 2        | 1        | 2        | 2        | 1               |    | 1               |
| Subject 16                  | 2  | 2        | 2        | 2        | 2        | 2               |    | 2               |
| Subject 17                  | 2  | 2        | 2        | 2        | 1        | 2               |    | 2               |
| Subject 18                  | 2  | 2        | 2        | 2        | 1        | 1               |    | 1               |
| Subject 19                  | 1  | 2        | 2        | 2        | 2        | 1               |    | 1               |
| Subject 20                  | 2  | 2        | 1        | 0        | 2        | 1               |    | 1               |
| Total Cond                  | 33 | 37       | 34       | 31       | 30       | 28              | 0  | 29              |
| Condition 2 A               |    | B        | C        | D        | E        | F               |    |                 |
| A                           |    | 0.042086 | 0.666264 | 0.577032 | 0.379263 | 0.056337        | 82 | 0.16255         |
| B                           |    |          | 0.082814 | 0.055257 | 0.004729 | <b>0.000873</b> |    | <b>0.002095</b> |
| C                           |    |          |          | 0.329877 | 0.214111 | 0.010163        |    | 0.020992        |
| D                           |    |          |          |          | 0.771534 | 0.379263        |    |                 |
| E                           |    |          |          |          |          | 0.540884        |    |                 |
| F                           |    |          |          |          |          |                 |    |                 |
| t.05(19)=+/-2.093           |    |          |          |          |          |                 |    |                 |
| 2 tailed, paired comparison |    |          |          |          |          |                 |    |                 |
| Bonferroni                  |    |          |          |          |          |                 |    | 0.003333        |

Hence reduced visual performance would reach statistical significance when 29 or fewer pedestrians were detected.

To convert this to a transmission level we interpolate between the performance at 33.4 % transmission (30 pedestrians detected) and the 19.6% transmission (28 pedestrians detected)

Significant transmission would therefore occur mid way between 19.6% and 33.4% i.e. **26.5%**

**6.12.2. Night-time with streetlighting and headlamps – dry road**

**Table 21: Significance calculations for night-time with streetlighting and headlamps - dry road**

| Ped 73                      | 82       | 74.5     | 51       | 45.3     | 33.4     | 19.6 | dummy data |          |          |          |    |
|-----------------------------|----------|----------|----------|----------|----------|------|------------|----------|----------|----------|----|
| Transmissi                  | A        | B        | C        | D        | E        | F    | x1         | x2       | x3       | x4       |    |
| Subject 1                   | 2        | 2        | 2        | 2        | 2        | 0    |            | 0        | 0        | 0        | 1  |
| Subject 2                   | 2        | 2        | 2        | 2        | 2        | 0    |            | 2        | 2        | 2        | 2  |
| Subject 3                   | 2        | 2        | 2        | 2        | 1        | 1    |            | 1        | 1        | 2        | 1  |
| Subject 4                   | 1        | 2        | 1        | 1        | 1        | 0    |            | 0        | 1        | 0        | 0  |
| Subject 5                   | 2        | 2        | 2        | 2        | 2        | 2    |            | 2        | 2        | 2        | 2  |
| Subject 6                   | 2        | 1        | 2        | 1        | 1        | 0    |            | 0        | 0        | 1        | 2  |
| Subject 7                   | 2        | 2        | 1        | 1        | 1        | 2    |            | 2        | 2        | 2        | 2  |
| Subject 8                   | 2        | 2        | 2        | 2        | 2        | 2    |            | 2        | 2        | 2        | 2  |
| Subject 9                   | 1        | 2        | 2        | 1        | 2        | 1    |            | 1        | 1        | 1        | 2  |
| Subject 10                  | 2        | 2        | 1        | 2        | 2        | 1    |            | 1        | 1        | 1        | 1  |
| Subject 11                  | 2        | 2        | 2        | 2        | 2        | 2    |            | 2        | 2        | 2        | 2  |
| Subject 12                  | 2        | 2        | 2        | 2        | 2        | 2    |            | 2        | 2        | 2        | 2  |
| Subject 13                  | 1        | 1        | 2        | 2        | 1        | 2    |            | 2        | 2        | 2        | 2  |
| Subject 14                  | 2        | 2        | 1        | 2        | 2        | 2    |            | 2        | 2        | 2        | 2  |
| Subject 15                  | 2        | 2        | 2        | 2        | 2        | 0    |            | 0        | 0        | 0        | 1  |
| Subject 16                  | 2        | 2        | 2        | 2        | 1        | 1    |            | 1        | 1        | 1        | 1  |
| Subject 17                  | 2        | 2        | 2        | 2        | 2        | 1    |            | 1        | 2        | 1        | 1  |
| Subject 18                  | 2        | 2        | 1        | 1        | 1        | 0    |            | 0        | 0        | 2        | 0  |
| Subject 19                  | 2        | 2        | 2        | 2        | 2        | 1    |            | 1        | 1        | 1        | 2  |
| Subject 20                  | 2        | 2        | 2        | 1        | 2        | 2    |            | 2        | 2        | 2        | 2  |
| Total Cond                  | 37       | 38       | 35       | 34       | 33       | 22   | 0          | 24       | 26       | 28       | 30 |
| Condition 2 A               | B        | C        | D        | E        | F        |      |            |          |          |          |    |
| A                           | 0.577032 | 0.42829  | 0.186411 | 0.103603 | 0.001576 | 82   | 0.003585   | 0.012118 | 0.01577  | 0.04926  |    |
| B                           |          | 0.267433 | 0.103603 | 0.020992 | 0.000766 | 74.5 | 0.001819   | 0.004036 | 0.014089 | 0.042086 |    |
| C                           |          |          | 0.666264 | 0.42829  | 0.005706 | 51   | 0.012118   | 0.035127 | 0.089626 | 0.09615  |    |
| D                           |          |          |          | 0.666264 | 0.006733 |      |            |          |          |          |    |
| E                           |          |          |          |          | 0.012118 |      |            |          |          |          |    |
| F                           |          |          |          |          |          |      |            |          |          |          |    |
| t.05(19)=+/-2.093           |          |          |          |          |          |      |            |          |          |          |    |
| 2 tailed, paired comparison |          |          |          |          |          |      |            |          |          |          |    |
| Bonferroni 0.003333         |          |          |          |          |          |      |            |          |          |          |    |

Hence reduced visual performance would reach statistical significance when 24 or fewer pedestrians were detected.

To convert this to a transmission level we interpolate between the performance at 33.4 % transmission (33 pedestrians detected) and the 19.6% transmission (22 pedestrians detected).

$$\text{Hence significant transmission} = 19.6 + 0.18(33.4-19.6) = \mathbf{23.16\%}$$

**6.12.3. Night-time with streetlights and headlamps – wet road**

Even the lowest level of transmission did not show a reduction in pedestrian detection rate.

**6.12.4. Night-time with headlamps only – dry road**

**Table 22: Significance calculations for night-time with headlamps only - dry road**

| Ped 73                      | 82 | 74.5     | 51       | 45.3     | 33.4 | 19.6     | dummy data      |      |          |          |          |                 |
|-----------------------------|----|----------|----------|----------|------|----------|-----------------|------|----------|----------|----------|-----------------|
| Transmissi                  | A  | B        | C        | D        | E    | F        | x1              | x2   | x3       | x4       |          |                 |
| Subject 1                   | 1  | 2        | 2        | 0        | 1    | 1        |                 | 1    | 1        | 1        | 1        |                 |
| Subject 2                   | 2  | 1        | 2        | 2        | 2    | 1        |                 | 1    | 1        | 1        | 1        |                 |
| Subject 3                   | 2  | 1        | 2        | 2        | 0    | 0        |                 | 1    | 0        | 1        | 0        |                 |
| Subject 4                   | 1  | 0        | 1        | 2        | 1    | 1        |                 | 2    | 1        | 0        | 1        |                 |
| Subject 5                   | 0  | 2        | 1        | 1        | 0    | 0        |                 | 1    | 1        | 1        | 1        |                 |
| Subject 6                   | 1  | 0        | 2        | 0        | 0    | 1        |                 | 0    | 1        | 0        | 1        |                 |
| Subject 7                   | 0  | 1        | 0        | 0        | 0    | 0        |                 | 1    | 1        | 1        | 1        |                 |
| Subject 8                   | 2  | 2        | 2        | 1        | 0    | 1        |                 | 2    | 1        | 2        | 1        |                 |
| Subject 9                   | 1  | 1        | 1        | 1        | 1    | 1        |                 | 1    | 1        | 1        | 1        |                 |
| Subject 10                  | 1  | 2        | 2        | 1        | 1    | 1        |                 | 1    | 2        | 1        | 2        |                 |
| Subject 11                  | 0  | 2        | 1        | 1        | 1    | 0        |                 | 2    | 0        | 2        | 0        |                 |
| Subject 12                  | 2  | 0        | 1        | 0        | 0    | 0        |                 | 1    | 1        | 1        | 1        |                 |
| Subject 13                  | 2  | 2        | 2        | 1        | 0    | 1        |                 | 0    | 0        | 0        | 0        |                 |
| Subject 14                  | 0  | 1        | 2        | 1        | 1    | 1        |                 | 0    | 2        | 0        | 0        |                 |
| Subject 15                  | 1  | 0        | 1        | 1        | 0    | 0        |                 | 1    | 1        | 1        | 1        |                 |
| Subject 16                  | 0  | 2        | 0        | 2        | 2    | 1        |                 | 1    | 0        | 1        | 0        |                 |
| Subject 17                  | 2  | 1        | 2        | 1        | 1    | 0        |                 | 0    | 1        | 0        | 1        |                 |
| Subject 18                  | 0  | 1        | 0        | 1        | 2    | 0        |                 | 0    | 0        | 0        | 0        |                 |
| Subject 19                  | 2  | 1        | 1        | 1        | 2    | 1        |                 | 0    | 0        | 0        | 0        |                 |
| Subject 20                  | 1  | 2        | 2        | 2        | 2    | 1        |                 | 0    | 0        | 0        | 0        |                 |
| Total Cond                  | 21 | 24       | 27       | 21       | 17   | 12       | 0               | 16   | 15       | 14       | 13       |                 |
| Condition 2 A               |    | B        | C        | D        | E    | F        |                 |      |          |          |          |                 |
| A                           |    | 0.590583 | 0.082814 |          | 1    | 0.479393 | 0.035127        | 82   | 0.329877 | 0.229644 | 0.167047 | 0.07239         |
| B                           |    |          | 0.505382 | 0.481035 |      | 0.12967  | 0.004036        | 74.5 | 0.088031 | 0.082814 | 0.014089 | 0.030201        |
| C                           |    |          |          | 0.186411 |      | 0.076138 | <b>0.000162</b> | 51   | 0.037392 | 0.004036 | 0.011546 | <b>0.001819</b> |
| D                           |    |          |          |          |      | 0.258452 | 0.01577         |      |          |          |          |                 |
| E                           |    |          |          |          |      |          | 0.171317        |      |          |          |          |                 |
| F                           |    |          |          |          |      |          |                 |      |          |          |          |                 |
| t.05(19)=+/-2.093           |    |          |          |          |      |          |                 |      |          |          |          |                 |
| 2 tailed, paired comparison |    |          |          |          |      |          |                 |      |          |          |          |                 |
| Bonferroni                  |    |          |          |          |      |          |                 |      |          |          |          |                 |
| 0.003333                    |    |          |          |          |      |          |                 |      |          |          |          |                 |

Hence reduced visual performance would reach statistical significance when 13 or fewer pedestrians were detected.



To convert this to a transmission level we interpolate between the performance at 33.4 % transmission (17 pedestrians detected) and the 19.6% transmission (12 pedestrians detected)

$$\text{Significant transmission} = 19.6 + 0.2(33.4-19.6) = \mathbf{22.36\%}$$

#### **6.12.5. Potential comfort benefits of reduced luminous transmission**

A theoretical assessment of the potential comfort benefits of reduced luminous transmission can be made by calculating the effects on the reduction in the transmission of light from oncoming vehicle headlamps. From this it is possible to make a prediction of the effect on the comfort sensation.

A model for predicting the comfort effects of a glare source was developed by Alferdinck (1996) and used to predict the discomfort glare sensation produced by vehicle headlamps. This model was the result of a series of experiments examining the effect of headlamp size on subjective ratings of glare. Alferdinck derived an equation which describes the discomfort glare **D** as a function of glare source area **A** (deg<sup>2</sup>), glare illuminance **E<sub>G</sub>** (lux) and glare angle **θ** (°).

$$\mathbf{D(E_G, A, \theta) = 3.15 - 2.19 \log(E_G) + 1.138 \log(\theta) + 0.298 \log(A) - 0.242 \log(\theta) \log(A)}$$

The output from this equation is a rating of discomfort analogous to de Boer's scale. For vehicle headlamps the values generated are within the range 1 to 9 with high ratings implying low discomfort. The scale descriptors used by de Boer are used (see below for de Boer's scale).

- 1 Unbearable
- 2
- 3 Disturbing
- 4
- 5 Just acceptable
- 6
- 7 Satisfactory
- 8
- 9 Just noticeable

For current purposes we have taken the illuminance of an the oncoming car headlamp as measured at point B50R in the beam pattern, which relates to the eye position of an oncoming driver (referred to as the 'glare point').

The table below shows that this would give a discomfort rating of 4.5 when viewed directly.

**Table 23**

| Point | Glare illuminance (lux) | glare angle | glare area (deg.sq) | discomfort glare |
|-------|-------------------------|-------------|---------------------|------------------|
| B50R  | 0.4                     | 3           | 0.413               | 4.5              |

By applying Alferdick's model and taking into account the effects of the reduction in illuminance under the different visor/windscreen transmission levels the effects on comfort have been estimated in the table below: -

**Table 24**

| Transmission % | Discomfort rating |
|----------------|-------------------|
| 82             | 4.7               |
| 74.5           | 4.8               |
| 51             | 5.1               |
| 45.3           | 5.2               |
| 33.4           | 5.5               |
| 19.6           | 6.0               |

This suggests that, with respect to comfort, there is a benefit to be derived from the use of lower levels of transmission at night that may move the sensation from being just unacceptable to acceptable.

Further investigations into discomfort glare are reported in section 10.

**6.13. Conclusions/recommendations**

This work has not found there to be a significant reduction in the ability to detect pedestrians at night until visor/windscreen transmissions fall below around 27%. (Dawn/dusk = 26.5%, Dry Night, lamp lit street = 23.16%, Dry night, until street = 22.36%, Wet night – lamp lit street = no effect on detection of any of the levels tested).

Estimates, based on mathematical models, indicate that visors or windscreens with such transmission levels will improve comfort during night-time driving/riding.

It is important to note that these findings are based on theoretical calculations, which were in turn based on laboratory tests. Considering the potential safety implications, it was decided to validate these findings by further objective laboratory tests and field trials.

## 7.0 Windscreen inclination - Installed luminous transmission

An additional factor that will decrease luminous transmission of a vehicle's glazing is its angle of inclination relative to the driver's line of sight. Most national standards relating to vehicle windscreens specify minimum limits of luminous transmittance, but only when measured at normal incidence. As installed inclination increases, luminous transmittance losses due to reflections at the surfaces and absorption within the bulk of the material also increase.

In a recent study, conducted by ICE Ergonomics (Quigley et al 2000), 27 cars between 0 and 3 years old were surveyed. Installed windscreen inclinations were found to range between 41° to 63° from vertical with an average of 59°. Typically, the decrease in luminous transmission over this range is approximately 10%.

Refer to Figures 25 and 26 below. To make allowances for windscreen inclination, it would be prudent to increase the luminous transmission levels used in ICE's work (which were based on measures of luminous transmission made perpendicular to the material) by up to 10% in order to be representative of on-the-road conditions. This adjustment does not affect our recommendation made in the previous section when applied to motorcycle visors. Motorcycle visors are likely to have angles up to 30° (Wigan 1979) which Figures 12 and 13 indicate have minimal effects on installed light transmission.

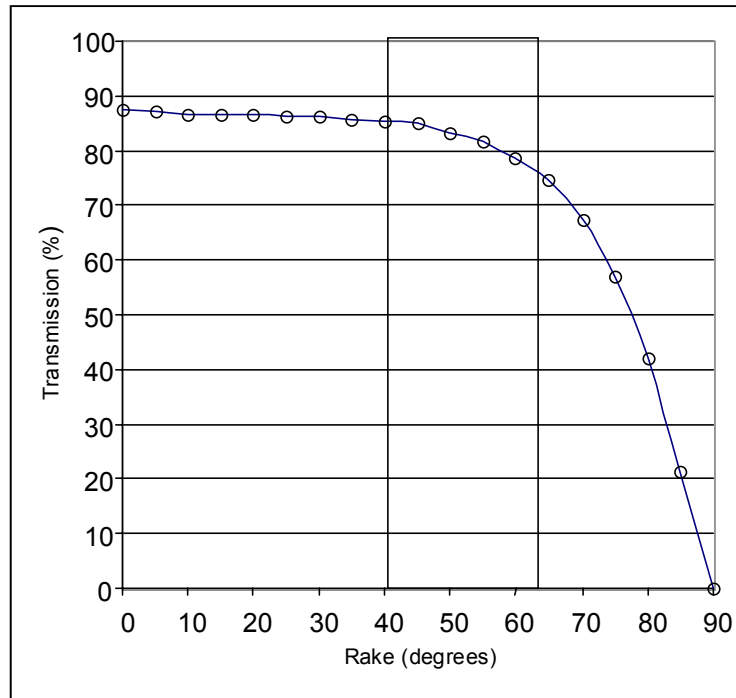

**Figure 12: Installed light transmission (from Smith, G. and Bryant, J.F.M., 1978, The optical properties of tilted windscreens under practical conditions)**

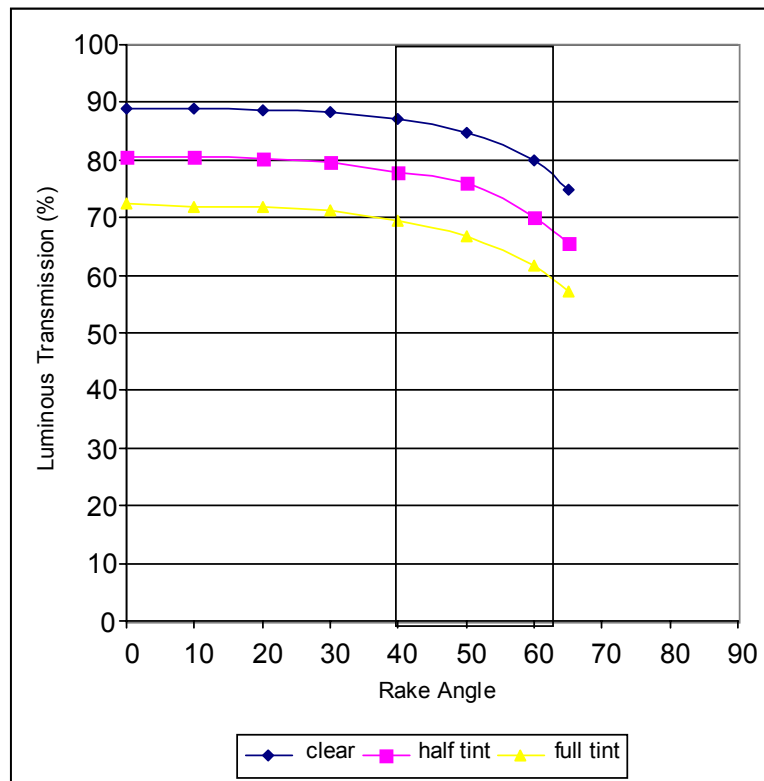

**Figure 13: Luminous transmission (from Hills, B.L., Transmittance measurements on windscreens and test samples: The effects of rake angle)**

## **8.0 Luminous transmission trials – Second laboratory study**

### **8.1. Aim**

In order to increase the data set of the initial laboratory study and therefore increase the “confidence” of the results, a further set of model road trials was undertaken. The design of the trials was subject to Peer Review where it was decided that the number of participants should be reduced from 20 to 10 with each participant being given ten repetitions of each condition. The aim of these model road trials was to confirm ambient conditions and transmission levels to be assessed in the field study. Visual performance under different transmission levels was measured by the number of correct detections. Refer to section 1.2 for Peer Group members.

### **8.2. Methodology**

#### **8.2.1. Ambient conditions**

As discussed in the peer review, the following lighting conditions were assessed in the model road:

- dawn/dusk,
- night-time with street lighting,
- night-time without street-lighting,
- night-time without street-lighting + glare source.

In addition, the bright daylight conditions was also included to confirm the results found in the previous model road trials.

#### **8.2.2. Number of participants**

Ten participants selected from the original participant listing were used. All participants were current UK driving licence holders (5 male and 5 female) whose ages ranged from 34 to 69 years (mean age 54 years, SD 13.5) were recruited from ICE Ergonomic's database. Two of the participants were also regular motorcyclists.

### **8.2.3. Transmission levels**

As agreed in the peer review, the three lowest transmission levels used in the previous trials were used again i.e. 45.3%, 33.4% and 19.6%. In addition, it was decided that a 74.5% luminous transmission level should also be included for comparison.

### **8.2.4. Targets and presentations**

The peer review agreed that the pedestrian only needed to be included in the trials. For each condition, there were 20 presentations; 10 with the target and 10 without the target.

### **8.2.5. Procedure**

For each ambient lighting condition, each participant viewed the road scene through each test material for a duration of 200ms. The pedestrian target was presented at the centre of the road at 73m distance from the participant. (All distances quoted are scaled 1/20). This distance equated to an approximate stopping distance i.e. thinking and braking distance, for a vehicle travelling at 60mph. The participants were required to indicate whether a target was present in the road scene and in order to detect a participant's willingness to guess at a target's presence, for each condition 50% of the road scene exposures had no target present. This was the same methodology used in the previous trials and reviewed by the peer group.

## **8.3. Results**

### **8.3.1. Dawn/dusk**

Figure 14 illustrates the effect of a material's luminous transmission on participants' ability to detect the pedestrian target at 73m under 'dawn/dusk' ambient lighting conditions.

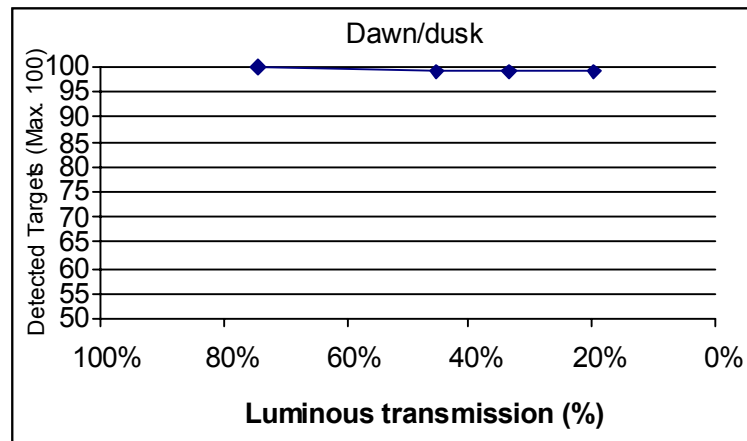

**Figure 14: Target detection under dawn/dusk conditions**

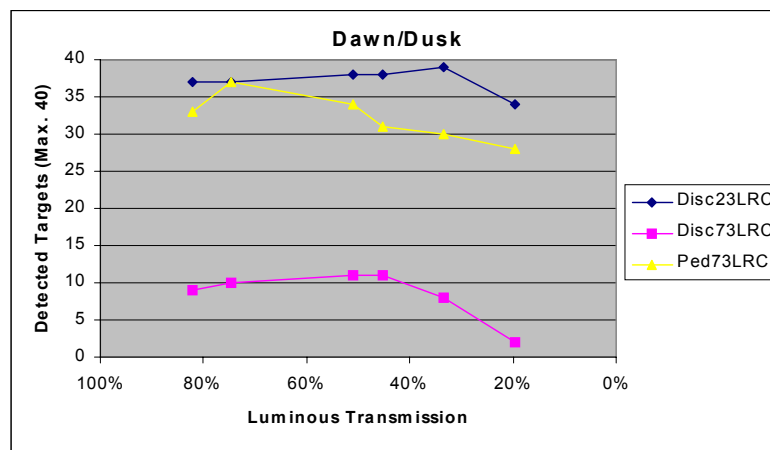

**Figure 15: Target detection results from previous trials (dawn/dusk)**

Statistical analysis<sup>1</sup> of figure 14 indicates that there is no significant difference across the different levels of luminous transmission for all of the targets i.e. the slight reduction in detection shown in Figure 14 is not significant and luminous transmission does not affect detection.

These results differ from the previous trials carried out; a significant difference in rate of detection with 19.6% transmission compared to 74.5% transmission was found in the initial laboratory study (Figure 15).

<sup>1</sup> All data was tested for statistical significance using a two-tailed, paired t-test at 5% significance. Any apparent differences between conditions which are not significant are due to natural variability in the data and are not due to transmission level. In addition, the data was analysed using the Bonferonni test as in the previous trials, and it is the results of this test that is reported on.



### 8.3.2. Night time with street lighting

Figure 16 illustrates the effect of a material's luminous transmission on participants' ability to detect the pedestrian target at 73m under 'night-time with street lighting' ambient lighting conditions.

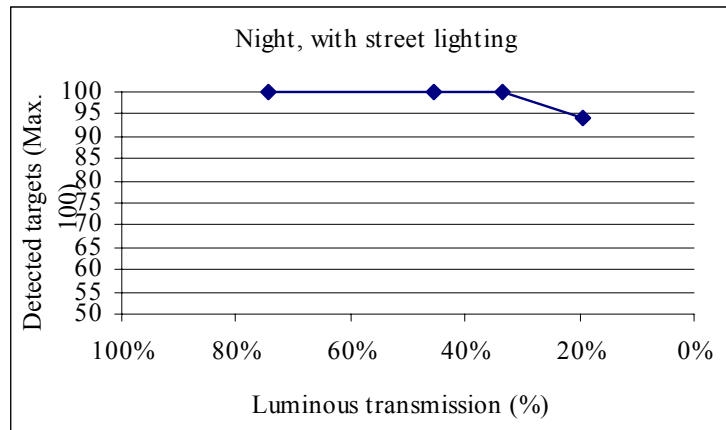

**Figure 16: Target detection under dry, night-time conditions with street lights**

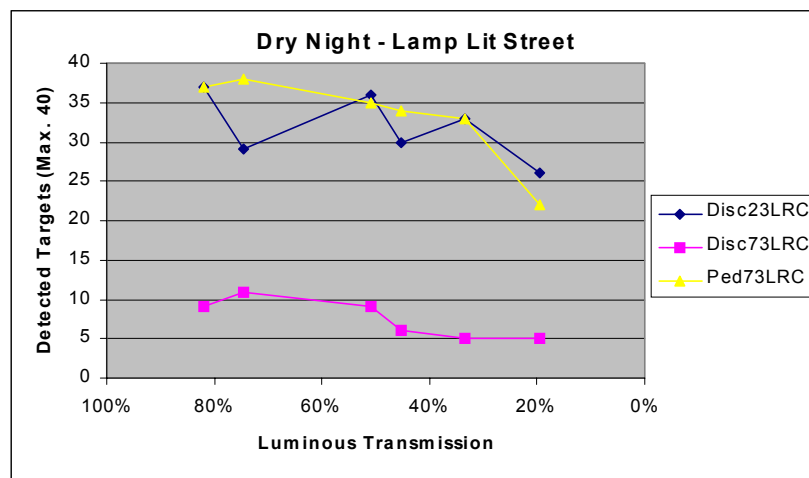

**Figure 17: Target detection results from previous trials (night, with street lighting)**

Statistical analysis of the data represented in figure 16 indicates that there is no significant difference across the different levels of luminous transmission for all of the targets i.e. the slight reduction in detection shown in figure 16 is not significant and luminous transmission does not affect detection.

These results differ from the previous trials carried out; a significant difference in rate of detection with 19.6% transmission compared to 74.5% transmission was found in the initial laboratory trials (Figure 17).

**8.3.3. Night time without street lighting**

Figure 18 illustrates the effect of a material's luminous transmission on participants' ability to detect the pedestrian target at 73m under 'night time without street lighting' ambient lighting conditions.

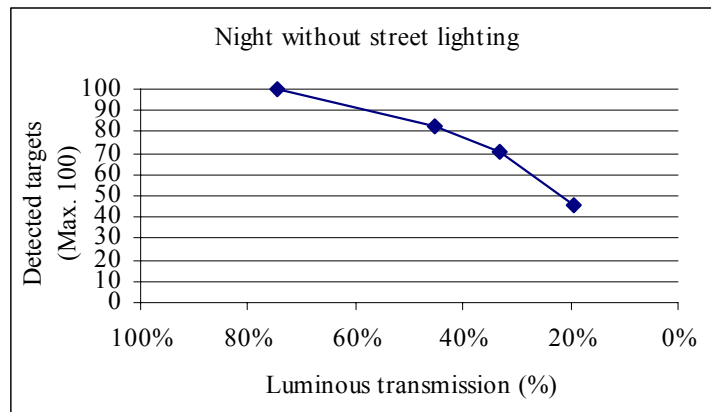

**Figure 18: Target detection under dry, night-time conditions without street lights**

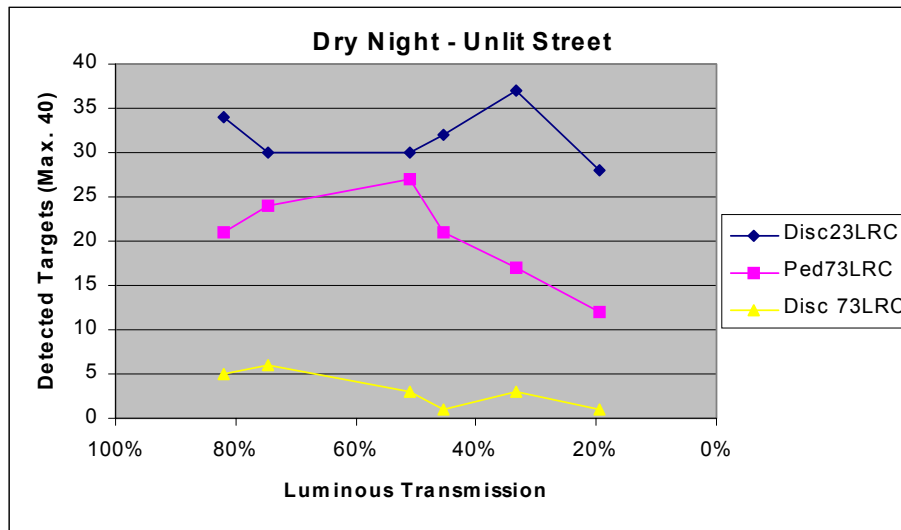

**Figure 19 Target detection results from previous trials (night, without street lighting)**

Statistical analysis of the data shown in figure 18 indicates that there was a significant difference in detection performance between the luminous transmission of 74.5% and 19.6% i.e. the reduction in detection shown in Figure 18 is significant and luminous transmission does affect detection (between 74.5% and 19.6%).

These results differ from the previous trials carried out. Previously, a significant difference was found between 51% and 19.6% but this was deemed likely to be result of experimental design rather than a true result (Figure 19). However, apart from this, no significant differences were found.

#### 8.3.4. Night time without street lighting (plus glare source)

Figure 20 illustrates the effect of a material's luminous transmission on participants' ability to detect the pedestrian target at 73m under 'night time without street lighting plus glare source' ambient lighting conditions.

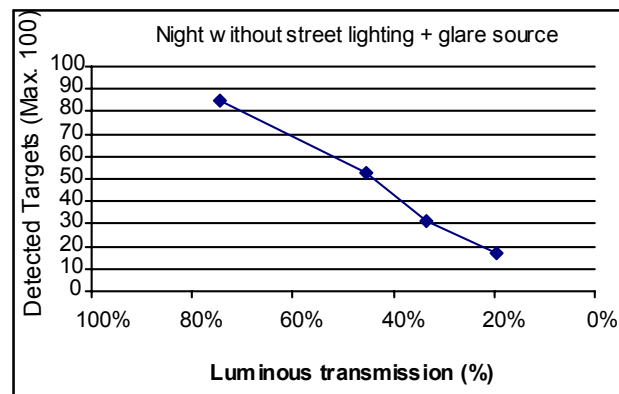

**Figure 20: Target detection under dry, night-time conditions without street lights and a glare source**

Statistical analysis indicates that there was a significant difference in detection performance between the luminous transmissions of 74.5% and both 33.4% and 19.6%. This would be expected since adding a glare source to an already difficult lighting condition will only further deteriorate the detection rate.

This result cannot be compared with the previous trials as this is an additional lighting condition which had not been investigated previously.

### 8.3.5. Bright daylight

Figure 21 illustrates the effect of a material's luminous transmission on subjects' ability to detect the pedestrian target at 73m under 'bright daylight' ambient lighting conditions.

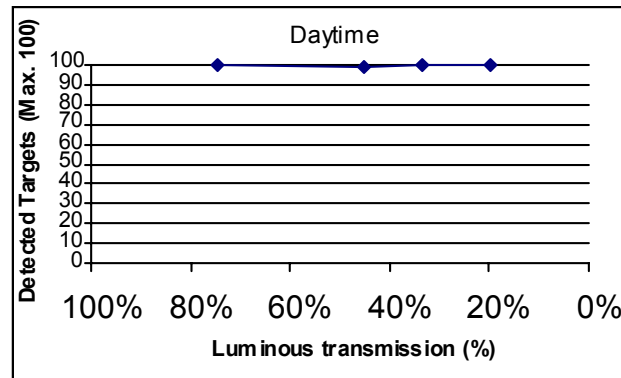

**Figure 21: Target detection under bright day conditions**

Statistical analysis indicates that there is no significant difference across the different levels of luminous transmission for all of the targets. In the previous trials, only the disc target was used, so no direct comparisons can be made. However, no significant differences were found even when the disc target was used.

### 8.4. Discussion

The results, as displayed in the graphs, appear to be broadly in line with intuitive expectations in so much as those conditions where some ambient lighting was present resulted in generally high detection rates whilst the two conditions with no ambient lighting (night-time without streetlighting both with and without a glare source) showed a decline in the number of correct detections, particularly for the lower transmission values.

In general the findings of these trials reflect the trends identified in the previous model road trials i.e. as transmission levels are reduced, visual performance (as measured by the proportion of correct detections of the target in the road scene)

decreases. This causes a characteristic downturn in the plot of the results as transmission levels reduce.

When comparing the data with that from the initial laboratory study, it appears that the plotted line relating to pedestrians detections has shifted upwards causing some of them to flatten e.g. dawn/dusk. This implies that for each transmission level the number of targets correctly identified has increased suggesting that the task undertaken by the participants was easier in these trials compared to the initial laboratory study. There are two reasons which can account for this, confirming the validity of the previous work:

- **Reduction in task variables:** In the initial laboratory study the participants had to detect a pedestrian *or* a disc either of which could appear at a number of locations across and along the road. In these trials only a pedestrian target was used and this was only shown in one location. These factors combined reduced the uncertainty of the detection task making it easier for the participants to correctly identify the presence of the pedestrian.
- **Increase in repetitions:** The factors outlined above were compounded by the fact that ten repetitions were applied to each set of conditions increasing the opportunity for practice at the task.

The increased ease of the task did not affect the findings relating to the bright daytime conditions since this task was quite easy even under the more demanding test conditions of the initial laboratory study, therefore little improvement could be made to the rate of detection and so the results of both sets of trials are not dissimilar.

The increased ease of the task did however affect the findings relating to dawn/dusk and night-time with street lighting when comparing both sets of trials. It is likely that this increased ease of detection caused the results to change from significant to non-significant. The increased ease of the task also suggests that the participants were operating above their threshold for detection implying that they were able to detect a higher proportion of the targets. This increase in target

detections over all transmission levels reduced the ability to detect a statistical difference in visual performance between the transmission levels.

With respect to the night-time without street lighting conditions, the results were significant (between 74.5% and 19.6%). This was potentially one of the worst case conditions to be undertaken since the lack of ambient lighting increased the difficulty of the detection task. The results of these trials would suggest that the lack of ambient lighting caused performance under the higher transmission levels to be more influenced by the increased ease of the task than under the lower transmission levels. This is feasible since at the higher transmissions, increased ease and practice may have improved performance, whilst under the lower transmissions the task may have been so inherently difficult that no amount of practice or reduced complexity would increase detection rates. This disproportionate improvement in detection performance for the high transmission values compared to the lower values may account for the significant finding in the results between the 74.5% and 19.6% transmission levels.

## **8.5. Conclusions**

These trials suggest that the critical condition to use in the field study is the night-time without street lighting with a glare source condition since it gave the highest transmission value (33.4%) which was significant when compared to 74.5%.

In addition, on those occasions in these trials where other significant differences were found, they occurred between 74.5% and 19.6%. This reflects the findings of the initial laboratory study.

In conclusion, when allowances are made for the adjustment in the experimental design, the results of the second series of trials do not appear to conflict with the findings of the first series.



## **9.0 Luminous transmission trials – Field study**

Peer reviews of previous experimental work using the model road identified the key experimental variables to incorporate into the real world testing of visor transmission levels. The aim of this field study was to investigate the effect on rider vision of varying levels of transmission under real world conditions and to provide information to guide an acceptable lower limit for luminous transmission.

### **9.1. Methodology**

#### **9.1.1. Procedure**

Each participant was assigned to a vehicle which they drove around a circuit which was approximately three miles long. The participant was accompanied by an experimenter who supervised the trial and collected data. The participants undertook four circuits under dusk conditions and four circuits under night-time conditions. For each circuit a motorcycle helmet of different visor transmission was used, the order of which was balanced across the trials. Along the route targets were positioned for the participants to detect. Upon detecting a target the participant had to state “Left” or “Right” at which point the experimenter activated a counter. The counter was let run until the front of the vehicle passed the target. The experimenter noted the participant’s response and the counter number which was later converted into the detection distance. The participants were familiarised with the test circuit and the targets prior to the trials and drove at approximately 25mph. The target positions were adjusted between circuits to reduce task familiarity.

#### **9.1.2. Targets**

In the model road trials, the targets used for detection were fixed at a scaled 23m and 73m from the participant which is equivalent to 30mph and 60mph stopping distance. Having identified from this work the critical ambient conditions, it was agreed amongst the peers that the field study would not use a fixed target distance but would use detection distance as a measure of participant performance i.e. how close would people get before they saw the target. Of the two targets used in the



model road trials, pedestrian and disk, it was considered to be more relevant to use the disk target. The disk target is more difficult to see since it is smaller than the pedestrian yet it is still important for the motorcyclist in terms of their road safety. Work by Narisada 1995 considered a target of 20cm to be the smallest object which is dangerous to traffic and referred to this as the critical object.

Ten 20cm disc targets with a 20% reflection factor were located around the circuit, randomly positioned to the right and left kerb locations which are less intense areas of the headlamp beam.

| Target | Target luminance (cd) | Road luminance (cd) | Road illumination (lux) |
|--------|-----------------------|---------------------|-------------------------|
| 1-3    | 15                    | 7                   | 170                     |
| 4-6    | 7.1                   | 2.7                 | 87                      |
| 7-9    | 3.5                   | 4.0                 | 60                      |
| 10     | 2.1                   | 2.8                 | 33                      |

**Table 25: Target and road ambient measures at the start of trials**

### 9.1.3. Measures

The measures used to assess the participant's performance under different transmission levels were:

- The number of targets detected,
- The distance at which they were detected.

### 9.1.4. Ambient conditions

#### *Dusk*

The initial laboratory study indicated that visor transmission had a significant effect on target detection under dusk conditions and this was not refuted by the second laboratory study. It also represents a condition in which the rider may accidentally be using an inappropriately dark visor i.e. light levels fall without the rider being aware. The starting time of the trial was related to the lighting up time. The mean ambient lighting condition values for the dusk trials are given in Table 26.

|              | Mean illumination (lux) |
|--------------|-------------------------|
| Circuit 1    | 217.86                  |
| Circuit 2    | 30.36                   |
| Circuit 3    | 10.99                   |
| Circuit 4    | 2.33                    |
| End of trial | 0.76                    |

**Table 26: Mean illumination for dusk trials**

***Night-time without streetlights + glare source***

This scenario equates to travelling along an unlit road with a vehicle with dipped headlights (the glare source) approaching from the opposite direction. This condition was only undertaken in the second laboratory study which generally gave higher detection rates than the initial laboratory study (due to the ease of the task). However since it was found to be the most difficult of the night-time tasks, it was selected for inclusion. Since the mean ambient lighting conditions at night are less variable than the rapidly changing light levels of dusk, night-time values were only sampled once. The mean night-time illumination was in the order of 0.1 lux.

**9.1.5. Test site**

The test site used was a privately owned disused airfield, now used as a driving circuit. The site was favoured for a number of reasons:

- It provided a relatively safe environment for work of this nature (the use of dark visors under dusk and night-time conditions) to be conducted,
- Being used for car driving, the road was of an acceptable standard,
- There was no night-time streetlighting.

**9.1.6. Transmission levels**

The following transmission levels were agreed at the last peer review:

80%, 43%, 28% and 18%. Since transmission materials suitable for automotive application are not infinitely variable in their transmission properties, the levels required above had to be approximated. To approximate:

- a clear visor of 80% transmission - just the windscreen was viewed through,
- a 43% visor – a daytime visor and the windscreen was used which equated to 47%,
- a 28% visor – a clear visor with windscreen tint film and windscreen was used which equated to 28%.
- an 18% visor – a dark visor of 21% and the windscreen which equated to 18%.

The transmission levels achieved by the combinations above were measured by Tintman, transmission meter, which the manufacturer states has an overall accuracy better than 3%.

The samples used for the field study were not dissimilar to those used in the model road trials and both sets of samples were representative of what could be found in use on the road i.e. automotive and motorcycle products. The model road samples were analysed by the Colour and Imaging Institute at Derby University who concluded that differences in detection performance were due to luminance i.e. transmission level, and not colour variations. All samples analysed by Derby met the requirements relating to Visual Attenuation Quotients.

The visors discussed above were then fitted to shop-bought crash helmets.

### 9.1.7. Vehicles

#### *Type of vehicle*

As discussed in the peer review, the vehicles used in the trials were cars. Using cars served two purposes:

- They provided a secondary task of a driving nature,
- It enabled close liaison of the experimenter with the participant for the purposes of safety, data collection and experimental control.

The vehicles used were two one-year old Ford Focus' which had the same headlamps as many motorcycles (halogen H4 lamps compliant with ECE Regulation 20). These were standard production models and were unmodified aside from having an oncoming glare source mocked-up and data collection equipment fitted, a fifth wheel.

***Glare source***

To create a controllable form of oncoming dipped headlamps (glare source) for use in the night-time condition, simulated approaching headlamps were constructed and mounted to the bonnet of each of the test vehicles; this was much the same methodology as that used by Alferdinck and Theeuwes (1997) in their study of the effects of oncoming glare sources. In the field study, the glare source was off-set to the right to represent an oncoming vehicle at approximately 50m. The intensity of the glare illumination at the drivers eye was in the order of 4 lux. Whilst this is higher than the regulations permit, it is not unrepresentative of the type of intensities which can be encountered on the road. These differences arise from in-service factors such as dirt on the headlamps altering the beam pattern, mis-aligned headlamps and the higher voltage supplied to the lights in practice compared to test conditions.

***Fifth wheel***

Fifth wheels used by ICE Ergonomics in previous work concerning driver vision were employed in these trials. A fifth wheel was attached to the rear of the vehicle and calculations, based on the number of revolutions, enabled the distance between where the participant identified the target and the location of the target itself to be measured.

**9.1.8. Number of participants**

Twenty participants were used in the trials; relevant data is given in Table 27 overleaf.

| Number | M/F | Age | Motorcyclist | Previous attendance |
|--------|-----|-----|--------------|---------------------|
| 1      | M   | 47  | Y            | N                   |
| 2      | M   | 28  | Y            | N                   |
| 3      | F   | 47  | Y            | N                   |
| 4      | M   | 62  | Y            | N                   |
| 5      | M   | 65  | Y            | N                   |
| 6      | M   | 25  | Y            | N                   |
| 7      | M   | 68  | Y            | Y                   |
| 8      | M   | 54  | Y            | Y                   |
| 9      | M   | 41  | Y            | N                   |
| 10     | M   | 58  | Y            | N                   |
| 11     | F   | 23  | N            | N                   |
| 12     | F   | 42  | Y            | N                   |
| 13     | M   | 42  | Y            | Y                   |
| 14     | F   | 19  | Y            | Y                   |
| 15     | F   | 22  | N            | N                   |
| 16     | M   | 20  | N            | N                   |
| 17     | F   | 22  | N            | N                   |
| 18     | F   | 34  | N            | Y                   |
| 19     | M   | 40  | N            | Y                   |
| 20     | F   | 40  | N            | Y                   |

**Table 27: Participant statistics**

## 9.2. Results

### 9.2.1. Dusk

#### *Detection rate*

The number of correct target detections, from a total of 200, is shown in Table 28 for each level of transmission.

|                              |     |     |     |     |
|------------------------------|-----|-----|-----|-----|
| Transmission level %         | 18  | 28  | 47  | 80  |
| Number of correct detections | 172 | 182 | 185 | 190 |

**Table 28: Dusk – Detection rate according to transmission level**

Statistical analysis<sup>1</sup> of this data indicates that there is no significant difference in the number of targets detected through each of the visor transmissions.

### ***Detection distance***

The detection distance, measured in terms of fifth wheel units, is given in Table 29. Each unit represents a fifth of a revolution of the measuring wheel and so provides a high degree of accuracy.

|                             |       |       |       |       |
|-----------------------------|-------|-------|-------|-------|
| Transmission level %        | 18    | 28    | 47    | 80    |
| Number of fifth wheel units | 150   | 141   | 218   | 226   |
| Detection distance (m)      | 26.35 | 24.79 | 38.44 | 39.84 |

**Table 29: Dusk – Detection distance according to transmission level**

Statistical analysis of the data relating to the fifth wheel units indicates that there are only significant differences in the detection distance between:

- The 80% visor and the 28% & 18% visors,
- The 47% visor and the 28% & 18% visors.

## **9.2.2. Night-time**

### ***Detection rate***

The number of correct target detections, from a total of 200, is shown in Table 30 for each level of transmission.

|                              |     |     |     |     |
|------------------------------|-----|-----|-----|-----|
| Transmission level %         | 18  | 28  | 47  | 80  |
| Number of correct detections | 181 | 185 | 187 | 190 |

**Table 30: Night-time – Detection rate according to transmission level**

Statistical analysis of this data indicates that there is no significant difference in the number of targets detected through each of the visor transmissions.

### ***Detection distance***

The detection distance, measured in terms of fifth wheel units, is given in Table 31.

|                             |     |    |     |     |
|-----------------------------|-----|----|-----|-----|
| Transmission level %        | 18  | 28 | 47  | 80  |
| Number of fifth wheel units | 133 | 95 | 141 | 144 |
| Detection distance (m)      | 23  | 17 | 25  | 25  |

**Table 31: Night-time – Detection distance according to transmission level**

Statistical analysis of the data relating to the fifth wheel units indicates that there are significant differences in the detection distance between:

- The 28% visor and the 80%, 47% & 18% visors.

### **9.2.3. Fatigue and learning effects**

As a means for determining if there were any fatigue or learning effects, the aim was to repeat the first circuit for both the dusk and night-time trials at the end of their respective blocks and make comparisons.

For the dusk trials, it was found that this was not possible due to the naturally failing light whilst for the night-time trials it was only possible to sample six of the twenty participants.

Statistical analysis of the results obtained at the start and end of the night-time trials indicated that there was no significant difference in detection rates or distances. This suggests that fatigue and learning effects were unlikely to have influenced the results.

---

<sup>1</sup> All data was tested for statistical significance using a two-tailed, paired t-test at 5% significance.

### 9.3. Discussion

#### 9.3.1. Dusk

##### *Detection rate*

The data in table 29 indicates, as might be expected, that as the transmission level reduces so does the detection rate of the targets. However statistical analysis indicates that this trend is not significant therefore implying that there is no difference between the four transmission levels tested.

##### *Detection distance*

In terms of the detection distance, a similar, broad trend can be observed in that as the transmission level reduces so does the detection distance. Statistical analysis indicates that the time taken to make those detection's is significantly different i.e. some transmissions enabled a target to be seen at a significantly greater distance than others. In summary the results were that:

- there was no significant difference in detection distances for visors with 80% and 47% transmission levels,
- visors with 80% and 47% transmission levels had significantly better detection distances than visors of 28% and 18% transmission levels. Using mean values, this equates to a difference in detection distances of 14m.

#### 9.3.2. Night-time

##### *Detection rate*

The data in table 31 indicates, as might be expected, that as the transmission level reduces so does the detection rate of the targets. However statistical analysis indicates that this trend is not significant therefore implying that there is no difference between the four transmission levels tested.

##### *Detection distance*

In terms of the detection distance, it can be observed that there is only a minimal reduction in detection distance as transmission level reduces. Since it is unlikely that the participants visual system could in some way be compensating for the change in transmission levels nor is it likely that detection distance is being



influenced by the range of the headlamps, the most likely explanation for this result is that the glare source is masking the target. Only when the vehicle is sufficiently close for its headlamps to raise the target luminance above the threshold for detection in the presence of the glare source, can the target be seen. However the effect of this is greater than the effect of the difference in the transmission levels hence the resultant minimal difference in detection distances between the 80% and 18% visors.

Further observation of the detection distance also shows an anomaly relating to the 28% visor which, statistical analysis indicates, has a significantly poorer detection distance than the other transmission levels assessed. This either indicates that peoples' vision is poorer through a 28% visor than an 18% visor or that there is some experimental artefact, other than transmission, responsible for this result. Analysis of the 28% visor indicates that the application of the automotive tint film to the visor gave rise to greater flaring of the glare source than for the other visors which therefore increased the task difficulty for this condition. It is argued therefore that the significant decrement in performance is due to a disproportionate degree of glare rather than an effect of the luminous transmission. Ergonomists, at ICE, who are experienced in the field of vehicle lighting and road user vision, are in agreement that this is an experimental artefact and not a true result. They therefore suggest that there is unlikely to be any significant difference in the detection distances for all four transmission levels.

## **9.4. Conclusions and recommendations**

### **9.4.1. Conclusions**

#### ***Dusk***

The results indicated that whilst there was no significant difference, in terms of detection rate and distance, between an 80% and a 47% visor, significant differences did arise when these levels were compared to 28%. Refer to Table 29.

***Night-time***

The night-time results for the field study indicated that there was no significant difference in performance due to transmission levels. This is likely to be because the combination of variables tested had a greater effect on performance than transmission; a different combination of variables may have resulted in a greater variability of the performance data across the transmission levels.

**9.4.2. Recommendations**

Based on the results obtained in the field study, it is suggested that a lower level for luminous transmission be set between 47% and 28%. However consideration of these results in conjunction with findings from other aspects of the research may assist in fine-tuning this lower level.



## **10.0 Expert appraisal of visor alternatives**

### **10.1. Introduction**

The luminous transmission trials investigated in detail the effects of tinting upon detection. Due to the need to prioritise the areas for investigation within the research programme, potentially viable alternatives to dark tinted visors were investigated by means of an expert appraisal. The aim of the Expert Appraisal was to evaluate a number of alternatives to dark tinted visors to determine the extent to which they could minimise glare without reducing visibility of the road ahead. The appraisal considered visual aspects of visor use in terms of safety and comfort.

- First appraisal: The potentially viable alternatives to dark visors (with a minimum light transmittance less than 50%) visors which were initially appraised were the two-stage, graduated and banded visors as well as the peak/no peak with clear visor options,
- Second appraisal: Upon reviewing the results of the first appraisal, it was decided to use the same approach to investigate the 50%, iridium and mirror insert visors. Whilst these were not considered to be potentially viable alternatives to dark tinted visors, an understanding of the affects of their use was considered to provide a useful contribution to the work.

## 10.2. Methodology

### 10.2.1. Helmet/visor systems assessed

Eight types of helmet/visor systems were assessed:

*A helmet fitted with a graduated visor.*



**Figure 22: Graduated visor**

The graduated visor chosen for the appraisal was a visor that was dark tinted (22% transmission) at the top edge, with the tint gradually reducing such that it was 59% at the middle of the visor and clear (89%) at the lower edge.

*A helmet fitted with a clear visor and a silver shade band.*



**Figure23: Helmet with silver shade band**

The shade band was obtained separately to the clear visor (91%) and was applied according to the manufacturers instructions in a way representative of road use. The

shade band (15% transmission when applied to visor) covered the top 4.5cm of the visor and did not obstruct the rider's view straight ahead.

*A 'Lazer Revolution' helmet fitted with a two-stage visor.*



**Figure 24: Lazer Revolution helmet**

The Lazer Revolution helmet has an integral sun shield (14%) which can be raised and lowered as required. It is located between the rider's eyes and the clear visor (85%). This is activated by way of a slider on the top of the helmet and, according to the manufacturers' literature, can be used one handed by a gloved hand in less than a second. The luminous transmission of the two-stage visor when the sun shield has been lowered is 12%.

*A helmet fitted with a peak.*



**Figure 25: Helmet with a peak**

Two peaked helmets were assessed, one with a detachable peak and one with an adjustable peak. The clear visor the expert looked through, which was used in conjunction with the peak, had a luminous transmission of 92%.

### *An iridium visor*

An iridium visor was obtained through the Internet. It was stated as part of the product description that this visor was not legal for use in the UK. The colouring on this visor varied concentrically from green in the centre of the visor to blue, purple and yellow. Transmission levels in the green/blue area of the visor i.e. the part looked through were 13%.



**Figure 26: Iridium visor**

### *A mirror insert for a visor*

This item was available on the Internet and the dark-tinted version was selected for use in the appraisal. Since the inserts are a tinted film, which is attached to the visor, the distributor states that "they are not classified as visors and so are not subject to the same regulations". The insert, used in conjunction with a clear visor, gave a transmission level of 30%.



**Figure 27: Dark tinted mirror insert**

***A 50% visor***

This was used as a benchmark to see how the alternatives perform against a daytime, legal use visor.

***A clear visor***

A clear visor of 92% transmission was used as a control. This enabled the relative performance of each visor/peak assessed in the appraisal to be compared to a visor meeting the current regulations for day and night-time use.

***Other alternatives***

**Conventional illegal dark visor:** It was deemed unnecessary to carry out the tests on a conventional illegal dark visor (i.e. 20% transmission) because the two-stage visor on the Lazer revolution helmet could be used in lieu of this.

**Photochromatic visor:** Whilst links were established with developers of photochromatic visors, none were sufficiently advanced for inclusion in the appraisal.

**Polarised visors:** Whilst polarised visors were also considered to be of potential benefit, none could be identified for use in the trials.

**Holovisors:** These were considered to be similar in concept to the iridium visor i.e. the use of external graphics, with the latter being considered to be a worst case.



### 10.2.2. Appraisers

Up to five ergonomists, two of whom were motorcyclists, participated in the appraisal.

### 10.2.3. Variables

The helmets/visors were tested under four lighting conditions:

- Bright sunny day;
- Low sun condition (glare source);
- Night with street lighting;
- Night with no street lighting and a glare source (i.e. oncoming headlights).

By testing each item under both day and night conditions, the benefits and disbenefits of each could be investigated (i.e. the ability of each item to improve performance under daylight conditions but not reduce performance under night conditions).

These specific lighting conditions were chosen for the testing following the laboratory trials. The bright, sunny day and low sun conditions were included to investigate the daytime benefits of alternatives assessed. The night with street lighting condition and the night-time with no street lighting and glare source condition were included as these were identified as significant in the laboratory trials. In addition, all these conditions enabled both ambient glare and direct glare to be tested during both the day and night.

### 10.2.4. Objective assessment

#### *Detection*

To provide a level of foundation upon which the in-house experts at ICE Ergonomics could base their opinion, a short test was devised to obtain objective data on the performance of each of the alternatives.

The objective test consisted of each of the experts being asked to look for a target in the model road which was gradually moved towards them. The target to identify was the position of a 2mm gap in the letter C (size 7mm). This enabled an added measure of

uncertainty to be introduced, as the expert was not only asked to detect the target, but to detect the “state” of the target, i.e. the gap is left, right, up or down (see below).



**Figure 28: Target positions used in detection trials**

The target was moved gradually towards the expert until they were able to detect the position of the gap. They notified the experimenter by saying “stop” and the detection distance was recorded. This was then repeated, except that the target was moved away from the expert until the experimenter was notified that the target was no longer visible and the distance was again recorded.

The test was conducted with the experts viewing through the darkest part of each visor (i.e. the upper part of the graduated visor, shade band and the sun shield and outer visor of the two-stage visor). This was undertaken so that the effectiveness of each device during the day could be investigated as well as its safety risks if misused at night. For the peaked helmet, the experts were asked to use it if they required it and to state whether they would use it or not.

### ***Usability***

In order to obtain a view on how efficient the visor/peak options were to use when changing between conditions of use, i.e. blocking out a sudden glare source, an additional short trial was undertaken.

Each expert was asked to wear each visor/peak option and look straight ahead through the clear part of it. The scene was blocked from view using the shutter mechanism used in the model road trials. When the shutter was dropped (which started the reaction timer), the expert was asked to either:

- a) tilt their head so that the tinted part of the visor or peak covered the glare source (for the graduated visor, visor band or peaked helmet) or;

- b) slide the sun visor or moveable peak down to help block out the glare source (for the two-stage visor and the helmet with the moveable peak).

Once either of these had been carried out, the expert was asked to notify by the experimenter by saying “stop” and the reaction time was recorded.

### 10.2.5. Subjective assessment

#### *Discomfort glare*

Using a modified version of the de Boer rating scale (see Figure 29), the expert was asked to give a discomfort glare rating of the road scene under the current ambient conditions while using the visor/peak. (The deBoer scale was modified to include a score of 10 when there was considered to be no glare present). This procedure was repeated for each of the eight visor/peak options and each of the four ambient lighting conditions.

|    |                 |
|----|-----------------|
| 1  | Unbearable      |
| 2  |                 |
| 3  | Disturbing      |
| 4  |                 |
| 5  | Just acceptable |
| 6  |                 |
| 7  | Satisfactory    |
| 8  |                 |
| 9  | Just noticeable |
| 10 | No glare        |

**Figure 29: The rating scale used to measure discomfort glare**

For the graduated visor, visor band and two-stage visor, the expert was asked whether they would prefer to use, or might be tempted to use, the darkened part of each of these visors under each of the lighting conditions. During the trials the experts were required to look through the darkened part of each visor in order for worst-case data to be obtained. The expert was also asked whether they would use the peak under each lighting condition, but were asked to use the peak in the trial only if they felt the need for it.

*General opinions*

The appraisers were asked for their general opinions on each test item concerning visual performance in terms of safety and comfort.

**10.3. Results**

The results obtained are based on the performance and opinions of a small number of experts which were gathered in two separate appraisals. Since detailed analysis would be unreliable, only broad trends in the data are discussed.

**10.3.1. Objective assessment***Detection distance*

Since the detection assessment was undertaken with the aim to provide an element of objective consideration to the expert appraisal rather than scientifically rigorous trials in their own right, the results obtained needed to be carefully interpreted.

Figure 30 shows the mean target detection distances when wearing each of the visors/peaks under the four ambient lighting conditions. As a comparison, the figure also shows the minimum stopping distances for various speeds. The results in this section do not include the time taken to adjust the device; this is discussed separately.

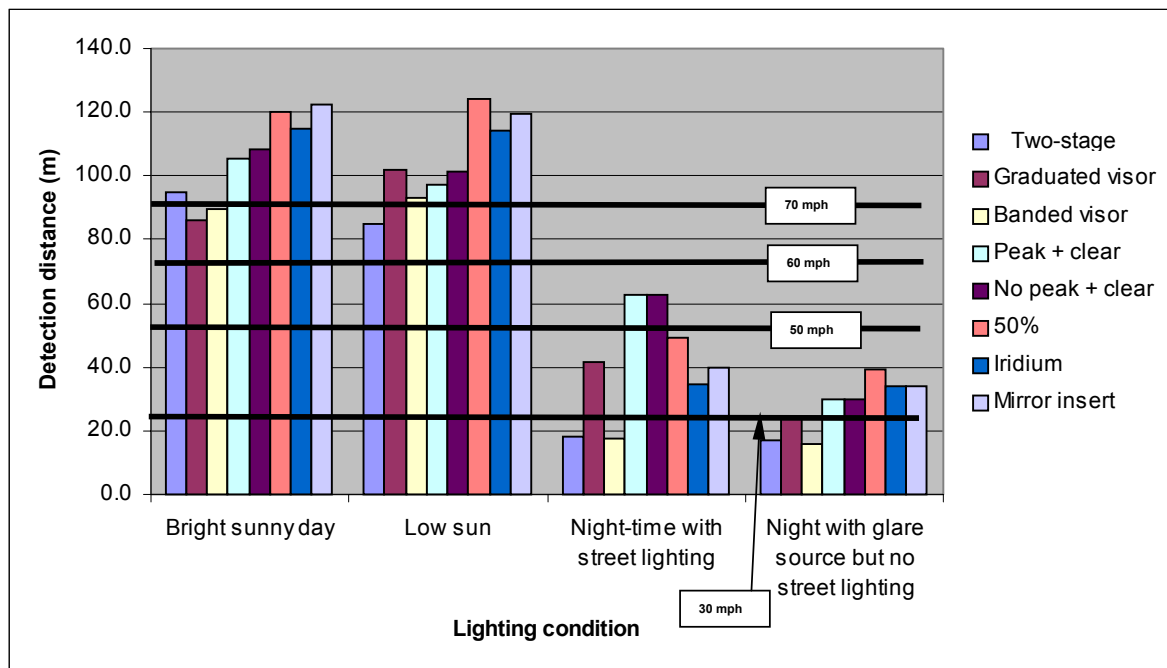

**Figure 30: The mean target detection distances when using each of the visors/peaks in comparison to the minimum stopping distances at various speeds as quoted in the Highway Code.**

**Two-stage visor:** The two-stage visor, with the tinted visor down, had reduced detection distances in all four conditions compared to the clear visor condition (No peak + clear) thus indicating detrimental performance if the two-stage visor is misused.

**Graduated visor:** The graduated visor when used in conditions where there was a glare source had detection distances similar to that of a clear visor, but poorer detection distances in conditions where there was no glare source. This suggests that there may be no real benefits to be gained in the use of this device in terms of target detection.

**Banded visor:** Viewing through the band on the visor reduced detection distances compared to the clear visor under all conditions, but this was particularly pronounced at night. However it may be assumed that detection performance through the clear part of the banded visor would be the same as viewing through the clear visor as both have similar transmission levels.

**Peak and clear visor:** The introduction of a peak to a helmet with a clear visor did not notably reduce detection distance under any lighting conditions. However, no improvements were found either. This suggests that there are no advantages or disadvantages to wearing a peak to aid detecting objects.

**50% visor and visor with mirror insert:** These visors appear to give rise to greater detection distances than the clear visor. It is possible that this may be a genuine phenomenon in that a degree of tinting assists detection or it may be that intra-participant differences over time are having an influence. (The 50%, iridium and mirror insert visors were appraised at a later date than the initial products). Only under night-time conditions with street lighting and no glare source did the clear visor give better results.

**Iridium visor:** The iridium visor, like the 50% and mirror insert visor, appears to give greater detection distances than the clear visor for all conditions except the night-time with street lighting and no glare source. However the detection distances for the iridium visor are less than for the 50% and mirror insert visors.

**Conclusion:** Under the night-time with street lighting and no glare source condition, all the visor options had a shorter detection distance than the clear visor. This was particularly the case for the two-stage and banded visors where detection distance was reduced to below 23m i.e. less than the 30mph stopping distance for three of the five experts.

### *Usability*

The speed with which the participants could change between different states of use was investigated with the results given in Table 32.

**Table 32: The mean adjustment times for each visor/peak and the distance travelled in this time at various speeds.**

| Visor/peak<br>(Level of luminous transmission %) | Mean<br>adjustment<br>time (seconds) | Distance travelled (m) |       |       |       |
|--|--------------------------------------|------------------------|-------|-------|-------|
|  |                                      | 30mph                  | 50mph | 60mph | 70mph |
| Two-stage visor (85/12)                          | 2.08                                 | 28                     | 46    | 56    | 65    |
| Graduated visor (22 -59-89)                      | 1.26                                 | 17                     | 28    | 34    | 39    |
| Banded visor (91/15)                             | 1.18                                 | 16                     | 26    | 32    | 37    |
| Clear visor with non-adjustable peak (92)        | 1.11                                 | 15                     | 25    | 30    | 35    |
| Clear visor with adjustable peak (92)            | 1.35                                 | 18                     | 30    | 36    | 42    |
| 50% visor  | Would need to stop to change visor   |                        |       |       |       |
| Iridium visor (13)                               |                                      |                        |       |       |       |
| Mirror insert (30)                               |                                      |                        |       |       |       |

The data indicates that for those devices which were adjustable between states whilst on the move, all the devices, aside from the two-stage visor, were similar in terms of adjustment times. The adjustment times in the table can be used to calculate how much distance would have been covered while the adjustment took place. However, as these reaction times also take into account the experimenter's reaction time to stop the timer, they should only be used for comparative means not for absolute measurements. It can be seen from Table 32 that when wearing the two-stage visor, the distances travelled while adjusting the sun visor varied from 10 to 30m more than the other devices (for speeds between 30 and 70mph). In comparison, the difference in distances between the other four devices was no more than 7m (for speeds between 70mph). These results suggest that the two-stage visor could pose the greatest safety risk to riders when trying to block out a glare source and removing it once the glare source had disappeared, while no major differences in ease of adjustability were found between the other four devices. However, from the general discussions with the experts (section 10.3.2), it was suggested that longer adjustment times for the two-stage visor were a result of the poor design of the slider control used to slide down the dark visor, and an improved design could improve adjustment times.

10.3.2. Subjective testing

*Discomfort glare*

Figure 31 shows the mean discomfort glare ratings given for each of the visor/peaks options under each of the lighting conditions.

**Figure 31: Mean discomfort glare ratings when wearing each visor/peak.**

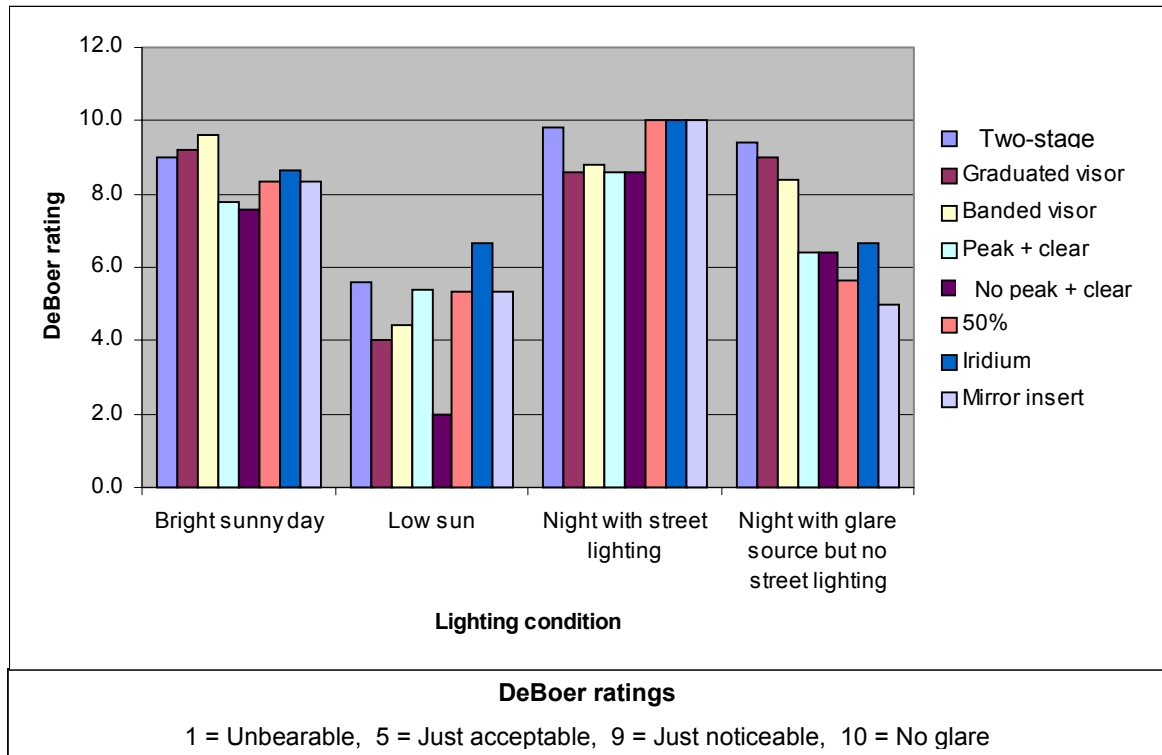

**Two-stage:** The two-stage visor, with the tinted visor down, resulted in less discomfort glare under all conditions than the clear visor and was never at an unacceptable level.

**Graduated visor:** The graduated visor resulted in less discomfort glare than the clear visor under all conditions except the night-time with street lighting condition when it had much the same rating. In the low sun condition the ratings for this device were less than acceptable.

**Banded visor:** The banded visor resulted in less discomfort glare under all conditions than the clear visor. Whilst its performance was not acceptable in the low sun



condition, when used under general bright ambient daylight conditions it performed the best of all the options assessed.

**Peak and clear visor:** The additional use of a peak in conjunction with a clear visor was of benefit in the low sun condition where its performance was better than some of the tinted visors.

**50% visor:** Discomfort glare through the 50% visor was never rated less than acceptable and generally resulted in less discomfort glare than the clear visors. The exception to this is the night-time condition without street lighting but with a glare source. This may be a real result or it may be due to intra-participant differences.

**Iridium visor:** The iridium visor resulted in less discomfort glare under all conditions than the clear visor and was never at an unacceptable level.

**Visor with a mirror insert:** The use of a mirror insert resulted in discomfort glare ratings which were broadly equivalent to or better than the clear visor with the exception being the night-time condition without street lighting but with a glare source. As for the 50% visor this may be a real result or may be due to intra-participant variations.

**Conclusions:** It can be seen from Figure 7 that for all visor/peak options that, excluding the low sun condition, the level of discomfort glare was considered to be favourable (ratings varied between just acceptable and no glare present) although this was generally less pronounced for the clear visor. The options which reduced discomfort glare to acceptable levels in the low sun condition, and so may be considered to be of real benefit in this respect were: the two-stage, 50%, iridium and mirror insert visors as well as the clear visor with a peak. However research has indicated that prolonged exposure to discomfort glare may reduce ratings i.e. perceived discomfort increases with length of exposure. A study by Olson and Sivak 1981 (reported in Olson et al 1992) found that the effect of glare duration received through rear view mirrors was worse by about one deBoer unit for the longer duration exposures. (The glare levels used ranged from 0.73 to 70 lux). In a further study (Olson et al 1992), it was again found that increased exposure increased perceived

discomfort. The discomfort ratings were worse by one half a deBoer unit for glare levels of 0.01 to 1.0 lux. These were lower levels than the previous study since these were simulating reflective materials applied to vehicles, not vehicle lighting. If prolonged exposure has a similar influence when using tinted visors, discomfort glare ratings may be worse by up to one deBoer unit. If this is the case then, whilst tinted visors would still reduce discomfort glare compared to clear visors, the benefit of these devices to turning unacceptable levels of glare into acceptable may become borderline.

It should be noted that these results are only valid for the 5 experts who took part in the testing and may not necessarily be applicable to all riders.

### *Preferences of use*

The results in the previous section were based on viewing through the darkened part of each of the visors (i.e. worst case scenario). For those visors where more than one state of use was available, the experts were asked to state their preference for use in a real-world situations under each of the four ambient lighting conditions. Table 33 shows these preferences for the five experts.

**Table 33: The number of experts who would prefer to use the shade band/sun shield/peak under each lighting condition**

| Visor/peak                        | Bright sunny day | Low sun | Night with street lighting | Night with glare source but no street lighting |
|-----------------------------------|------------------|---------|----------------------------|--|
| Banded visor                      | 4                | 5       | 0                          | 0  |
| Peak with clear visor             | 1                | 5       | 0                          | 2  |
| Two-stage visor (sun shield down) | 5                | 5       | 0                          | 0  |

The data in Table 33 suggests that the experts would be unlikely to want to use the tinted part of the banded or two-stage visor under night-time conditions. Whilst for these visors, there is a definite distinction between the tinted and clear areas, for the graduated visor this is not the case and preferences between the clear and dark tinted states may exist. To investigate this the experts were asked to state through which part

of the graduated visor they would prefer to look under each of the ambient lighting conditions. The luminous transmission of that specific part of the visor was then recorded using the Tintman – vehicle window transmission meter. (This is a technical instrument used by a number of police forces to measure window and visor transmission levels). The results are shown in Table 34.

**Table 34: Luminous transmission levels of the graduated visor at the experts' eye point**

| Expert | Luminous transmission levels (%) |         |                            |  |
|--------|----------------------------------|---------|----------------------------|--|
|        | Bright sunny day                 | Low sun | Night with street lighting | Night with glare source but no street lighting |
| 1      | 32                               | 27      | 27                         | 89   |
| 2      | 46                               | 22      | 86                         | 86   |
| 3      | 32                               | 22      | 32                         | 46   |
| 4      | 46                               | 32      | 73                         | 59   |
| 5      | 59                               | 22      | 73                         | 86   |
| Mean   | 43                               | 25      | 58                         | 73   |

The data in Table 34 indicates that there is possibly some potential for riders to misuse the graduated visor at night, as there are a couple of instances where the experts were looking through parts of the visor under night conditions with transmissions less than 80%. The likelihood of misuse occurring is discussed in more detail in section 10.4.2.

### ***General opinions***

When asked about the usability and effectiveness of each of the visors/peaks, the general consensus was that all of the devices assessed would help to reduce glare during the day and at night, although at night the negative effects of reduced visibility outweighed the positive effects of reduced glare. However, a number of specific comments were made about each of the devices.

**Two-stage visor:** A number of advantages were cited regarding the two-stage visor. It was useful in blocking out both ambient and direct glare sources and did not have to be “all or nothing” i.e. it could be used like a visor shade band and just pulled down half-

way to block out a high glare source, like low sun. In terms of usability, the two-stage visor was also considered to be the best as it could be changed in a short time, once the rider had had some practice. It could be undertaken without having to stop or having to ride with the head in an uncomfortable position, which could happen with the visor shade band, graduated visor or static peak. The two-stage visor was considered to offer an alternative to sunglasses, particularly since the tinted device is protected by being placed on the inside. (Tinted devices can be more expensive to replace than clear ones and therefore may become more degraded before replacement occurs). Another advantage to having the darker visor on the inside is that it is closer to the rider's eyes, therefore giving better visual clarity.

The two-stage visor also gave rise to some negative comments. The control was considered too small to be able to be used with any speed or accuracy, particularly when wearing thick winter riding gloves. Also, if the visor was to jam with the dark visor down, this would certainly cause a rider visual problems if the ambient lighting conditions were to change (i.e. riding from day into night or into a dark tunnel). However, the two-stage visor was generally considered to be a good concept if the usability issues were to be overcome.

**Graduated visor:** The visor with the graduated tint was not strong enough to completely eradicate more direct glare sources, such as the low sun, but did help with the reduction of ambient glare. A favourable aspect to its use was that it was not "all or nothing" like the visor band since it was possible to get an acceptable level of tint without having to bend the head excessively. However, this was also seen as one of the graduated visor's disadvantages. Although this visor wasn't considered as being a threat to visibility at night, the objective results still do show a reduction in detection distance. As it is possible that the rider may not be so aware of looking through the darker parts of the graduated visor than they would with the visor band, there could be a greater likelihood that riders would look through the darker tint at night. Another issue which should be considered is fogging. When visors do fog, it tends to build up near the bottom of the visor. With a graduated visor, this may force the rider to use a higher up part of the visor (i.e. the darker part) and this in turn may cause visibility problems at night.

**Banded visor:** The silver shade band was considered useful for blocking out direct glare sources, such as the low sun, but not so effective in blocking out ambient glare. Although looking through the dark band would greatly reduce visibility (and therefore detection distance) at night, the likelihood of a rider misusing the band at night would be much less as the rider would know when they were looking through the band. This is unlike with the graduated visor, where the rider may not realise they are looking through the darker part of the visor. Therefore, at night, a visor with a shade band would be less hazardous than a graduated visor because the rider can view the road through the clear part of the visor. In addition no adverse comments were given by the experts, with regard to any restrictions to peripheral vision being imposed by the shade band.

**Clear visor with a peak:** Peaked helmets were considered the worst for blocking out general ambient glare but good for blocking out a specific glare source which was not in the rider's direct line of sight, like the sun. The peak involved too much head movement to be of any use to blocking out any glare source at eye level. One suggestion would be to have a peak which was tinted so it would help to block out low sun but would also be able to be used for glare sources such as a wet road which is reflecting the sun. For daytime use, the use of the peak could be improved by using it in conjunction with another device, such as the graduated visor. At night, the peak offered no visual advantage to the rider, but this could also be an advantage in itself, as it is kept out of rider's line of sight when it is not needed, so is not a safety hazard.

Opinions were also sought about the difference between the moveable peak and the fixed but removable peak. The moveable peak would give the rider the ability to block out any glare if required without having to move their head position. However, it would mean the rider would have to remove their hand from the handlebars for approximately a second to operate the visor, which is not ideal. The static peak would not require the rider to remove their hands from the handlebars but may result in the rider having to adopt an awkward head position to help block out the sun. However, at night the static peak does not obstruct the view of the road ahead as the moveable peak may do in its fully lowered state.

**50% visor:** The 50% visor, when compared to the iridium visor and mirror insert, was considered by some to be the worst alternative for daytime use (because it was not so effective in reducing glare) although another expert considered that it was no better or worse than these alternatives. At night-time this visor was considered to be worst under conditions of glare but best when there was no glare as definition was not reduced so much.

**Iridium visor:** Generally the iridium visor was considered to provide good comfort levels under daytime conditions since it cut down on direct and ambient lighting. It was considered to minimise eyestrain and the colouring it offered was preferred by some of the experts. Whilst one expert considered that the iridium visor was not as dark to look through as expected, it was not generally favoured under night-time conditions. Colour was not commented upon with respect to vision through the visor.

**Visor with a mirror insert:** The visor with the mirror insert was considered by one expert to be worse than the iridium and 50% visors in terms of the poor glare reduction and poor definition under daytime conditions, although it was considered better for night-time use.

**The likelihood of misuse and abuse:** The likelihood of misuse (i.e. when the device is unintentionally used in inappropriate conditions) and abuse (when the device is intentionally used in inappropriate conditions) was also considered.

Of all the devices assessed, all have the potential to be abused, as there will always be a minority who will knowingly use the devices in inappropriate conditions. There may be various reasons for this including not riding with suitable alternatives, using illegally dark visors as a fashion statement, etc. However some aspects of abuse may be reduced if changing from the tinted to untinted state can be more conveniently undertaken than stopping to swap to a clear visor.

There may be a greater chance of the graduated visor being misused since riders may be less aware that they are viewing inappropriately through the visor because of its graduated nature than they would with the other visor alternatives considered.

## **10.4. Discussion**

### **10.4.1. Two-stage visor**

The two-stage visor, when compared to a clear visor, reduced glare arising from ambient lighting and direct light, although it was more effective with respect to the latter. It was rated as one of the best performing devices in the low sun condition, potentially providing the ability to reduce unacceptable glare to just acceptable levels.

The two-stage visor resulted in shorter detection distances than the use of a clear visor. It was one of the poorest of all the devices tested in this respect when used in the low sun and night-time conditions.

It was the most versatile of the devices appraised and although it was the slowest to adjust, this could be overcome by improving the sun visor control design and allowing for some practice before riding. The likelihood of misuse is less than with a tinted visor and a graduated visor as the sun visor can be removed once daylight begins to diminish without having to stop, although the risk of the sun visor jamming needs to be considered.

### **10.4.2. Graduated visor**

The discomfort glare ratings indicated that, compared to a clear visor, use of the graduated visor reduced glare arising from ambient lighting and direct light sources, although it was more effective with respect to the latter. It was however the poorest of all the devices tested in the low sun condition in this respect and was not rated at an acceptable level.

The objective testing found that use of the graduated visor resulted in comparable detection distances to a clear visor in the low sun condition but was the poorest of all the devices tested i.e. had the shortest detection distance under the bright sunny day condition. Its detection performance if misused at night was also poor.

The graduation allowed an acceptable level of tint to be obtained, if required, without having to bend the head excessively. However there are concerns that this device may

be misused at night as riders' natural preference and/or riding posture may result in them viewing through an inappropriately tinted part of the visor.

#### **10.4.3. Banded visor**

The discomfort glare ratings indicated that, compared to a clear visor, the use of a visor shade band reduced glare arising from ambient lighting and direct light sources, although it was more effective with respect to the latter. Whilst this device received the most favourable ratings of all the devices tested under the bright sunny day condition, under the low sun condition it was rated as less than acceptable, but better than a clear visor.

The use of the shade band resulted in shorter detection distances than the use of a clear visor and was one of the poorest of all the devices tested in this respect when used in the night-time conditions.

Although it would be easier for the rider to know they were looking through the darkened section of the visor than with the graduated visor, this may still occur as riders accommodate certain riding postures.

#### **10.4.4. Clear visor with a peak**

The use of a peak was rated as one of the best performing devices in the low sun condition, potentially providing the ability to reduce unacceptable glare to just acceptable levels.

With respect to detection distances, these were generally good performing on a par with the clear visor only option.

It was suggested that the use of the static peak might be improved if it was tinted or used in conjunction with the graduated visor. The likelihood of misuse at night is low with both the static and removable peak.



**10.4.5. 50% visor**

Discomfort glare was generally reduced through the use of the 50% visor compared to the clear visor, potentially providing the ability to reduce unacceptable glare to just acceptable levels.

Whilst the 50% visor generally gave rise to greater detection distances than the clear visor (this may be a real result or due to intra-participant variations), these were shorter for the night-time with street lighting condition.

Misuse of this product may occur if riders inadvertently continue to use the visor beyond daytime conditions.

**10.4.6. Iridium visor**

The iridium visor reduced discomfort glare levels compared to the clear visor, potentially providing the ability to reduce unacceptable glare to just acceptable levels.

Whilst the iridium visor generally gave rise to greater detection distances than the clear visor (this may be a real result or due to intra-participant variations), these were shorter for the night-time with street lighting condition.

Misuse of this product may occur if riders inadvertently continue to use the visor beyond daytime conditions.

**10.4.7. Visor with a mirror insert**

Discomfort glare was generally reduced through the use of the mirror insert compared to the clear visor, potentially providing the ability to reduce unacceptable glare to just acceptable levels.

Whilst the mirror insert generally gave rise to greater detection distances than the clear visor (this may be a real result or due to intra-participant variations), these were shorter for the night-time with street lighting condition.

Misuse/abuse of this product may occur if riders inadvertently/deliberately continue to use the visor with the mirror insert in situ beyond daytime conditions.

## **10.5. Conclusions**

### **10.5.1. Summary of findings**

#### ***Detection distance***

Detection distance is likely to be maximised, day and night, if a clear visor is used i.e. darker forms of visor did not aid detection.

#### ***Discomfort glare***

For daytime use, all visor alternatives reduced discomfort glare compared to a clear visor. However real benefits i.e. reducing ratings from unacceptable to just acceptable, were only found for the two-stage, 50%, iridium and mirror insert visors as well as the clear visor with a peak in the low sun condition. However these alternatives, aside from the peak, are likely to give rise to reductions in detection distance in night-time, street lit conditions if misused at night.

#### ***Usability***

In terms of usability, visors which have a complete uniform coverage of the tint at a level which will necessitate carrying a spare, clear visor and stopping to swap to use it are the least favoured. Alternatives which offer flexibility across different states of use whilst riding are therefore favoured for their convenience. Whilst all types of visors can be abused (knowingly used in inappropriate conditions), the graduated visor appears to be most vulnerable to misuse (unintentionally viewing through an inappropriately tinted area of the visor) and so is not favoured. Visors which require a deliberate action to adjust between the different states of use would therefore appear preferable although the ease and speed of this adjustment is an important factor.

### 10.5.2. Solutions

#### *Peak*

Whilst a peak offers potential benefit against a low sun and does not compromise detection distance, it is not as effective in reducing glare from high ambient illumination as some reduced transmission levels.

#### *Two-stage visor*

The two-stage visor was particularly effective in reducing glare from direct light such as a low sun although it gave rise to some of the shortest detection distances when used in this and the night-time conditions. Since the two-stage visor requires a deliberate action to adjust between the dark and clear states, this will help to reduce misuse. With improve operability, it appears to offer a good compromise.

#### *Reduced transmission levels*

It may be possible that transmission levels can be reduced across the whole of the visor without compromising the detection distance and so permit some reduction in discomfort glare. It is unlikely however that this will be to an extent that all discomfort glare will be rated as acceptable.

#### *Photochromatic visors*

The ideal product would be one with which an adequate minimum level of tinting is provided, according to the specific lighting conditions, by a means which is reliable, quick and easy to use and difficult to misuse. The photochromatic visor goes a long way towards achieving this; one expert mentioned the benefit of photochromatic glasses when riding. Whilst photochromatic visors are currently being developed, it was too early for their inclusion in this work.

#### *Polarised visors*

A polarised visor may also offer some benefits and should be investigated subject to availability.

## **11.0 Windscreen abrasion trials**

Long-term exposure to the elements and prolonged usage of windscreen wipers causes the outer surface of a windscreen to become pitted and abraded. This surface damage causes light to be scattered as it passes through the windscreen. The resultant veiling glare can cause areas of the road scene to be obscured to the driver. When an on-coming light source, such as a headlamp beam, passes through a clean, undamaged windscreen the glare will be disabling but localised at the sources centre. Abrasion on a windscreen's surface causes an increase in the area and luminance of the veiling glare around the headlamp's centre.

### **11.1 Methodology**

As a means to investigate the correlation between abrasion on a windscreen's surface and the resultant luminance of the veiling glare, twenty-four windscreens were obtained from a windscreen replacement company. Each of the windscreens was an original, factory-fitted item so that a vehicle's mileage, recorded at the time of replacement, might accurately indicate exposure duration. The exposure mileage for each of the windscreens tested is shown below in Figure 14.

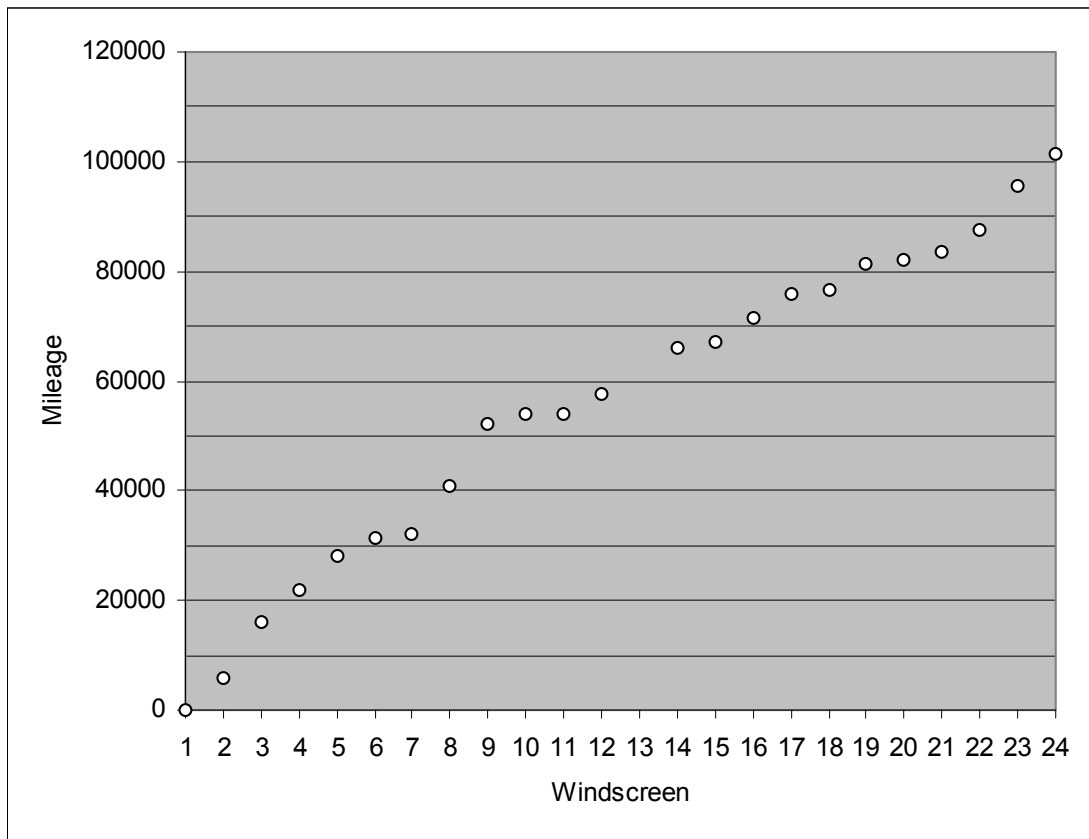

**Figure 32: Exposure mileage for windscreen sample**

### 11.1.1. Test apparatus

To measure the luminance of the veiling glare, created by a light source passing through an abraded windscreen, a test methodology was developed that utilised a digital, photometric image analysis system. The IQ-Cam system consists of a photometrically calibrated, digital, still frame camera connected to a host computer. Images captured by the camera are converted to a digital form so that the IQ-Cam software can perform photometric scene analysis and report measurements.

The test apparatus consisted of a tungsten filament lamp positioned at the end of a parallel-sided tube that was directed towards the IQ-Cam lens through a test windscreen. To prevent over exposure of the image at the lamp's centre, a solid disc the same diameter as the tube was placed on the windscreen directly between the light source and the camera. So that measurements were taken under consistent

ambient lighting conditions the apparatus were housed in a light proof box. Refer to Figure 15.

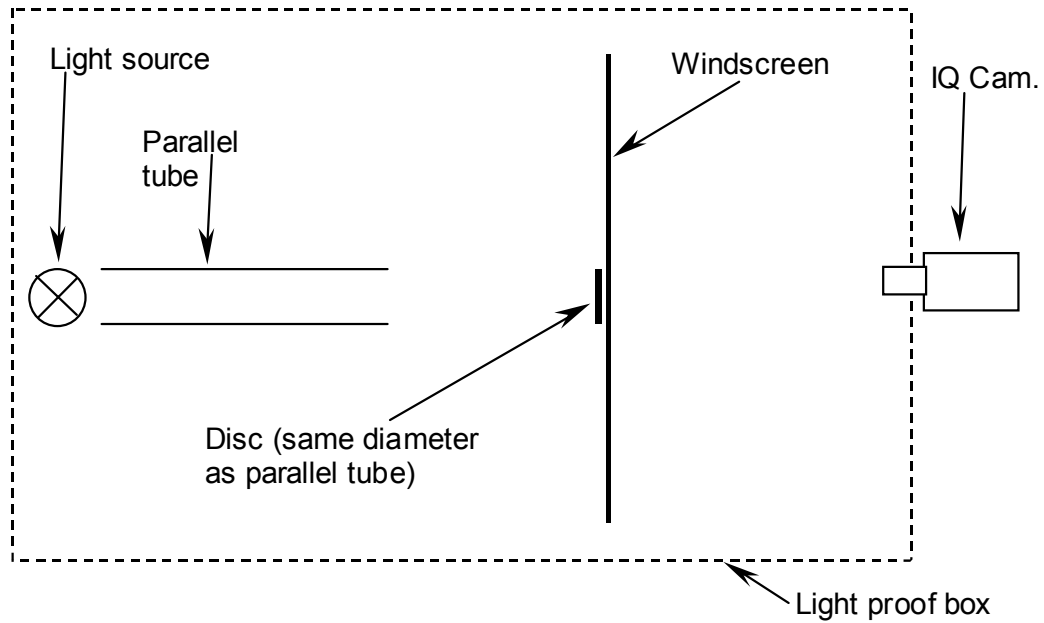

**Figure 33: Test apparatus used to measure veiling glare luminance**

Examples of IQ-Cam images illustrating increased veiling glare luminance as a result of increased mileage exposure and subsequent abrasion are shown below in Figure 34.

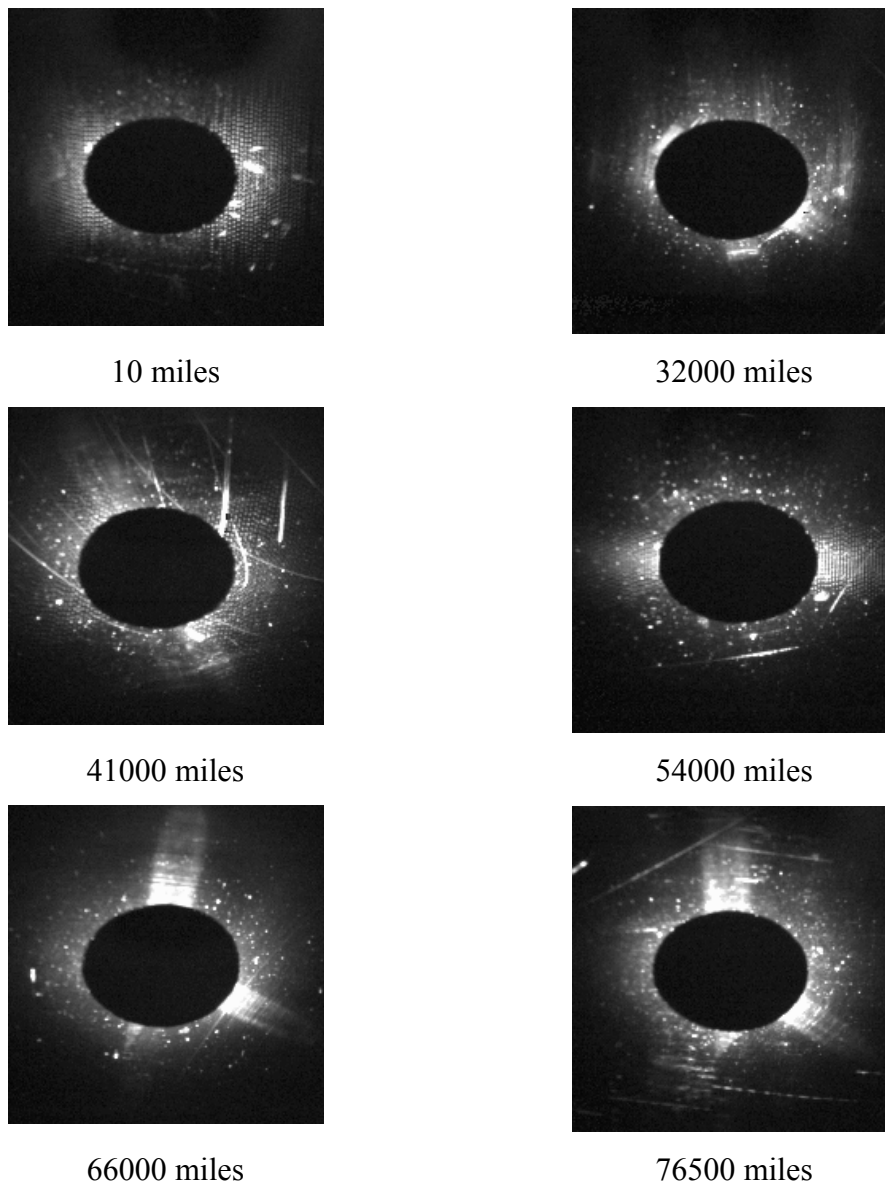

**Figure 34: Examples of IQ-Cam images of veiling glare luminance**

## 11.2 Results/Findings

The IQ-Cam software was used to measure the mean luminance of the veiling glare around the disc. When plotted against the windscreen's exposure mileage an increasing trend in the luminance of the veiling glare can be seen as illustrated in Figure 35.

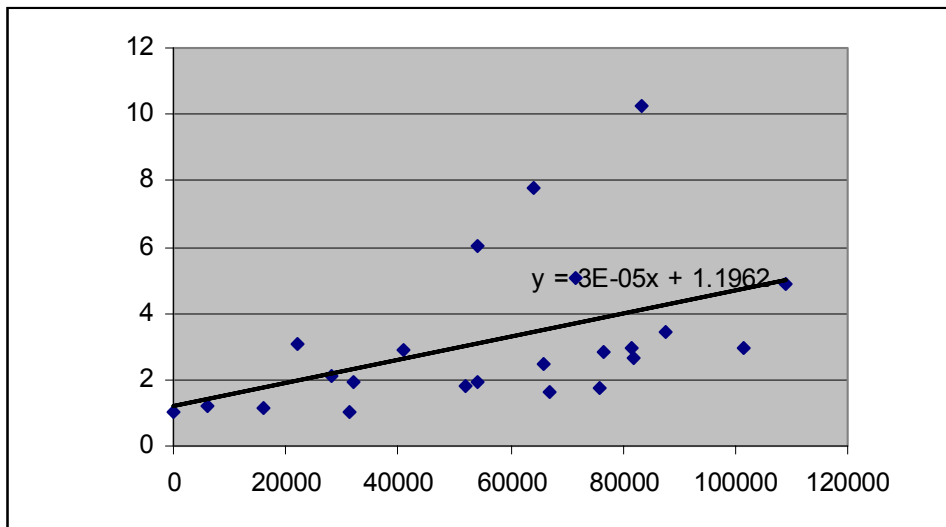

**Figure 35a: Relationship between the mean veiling glare luminance and exposure mileage for windscreen sample**

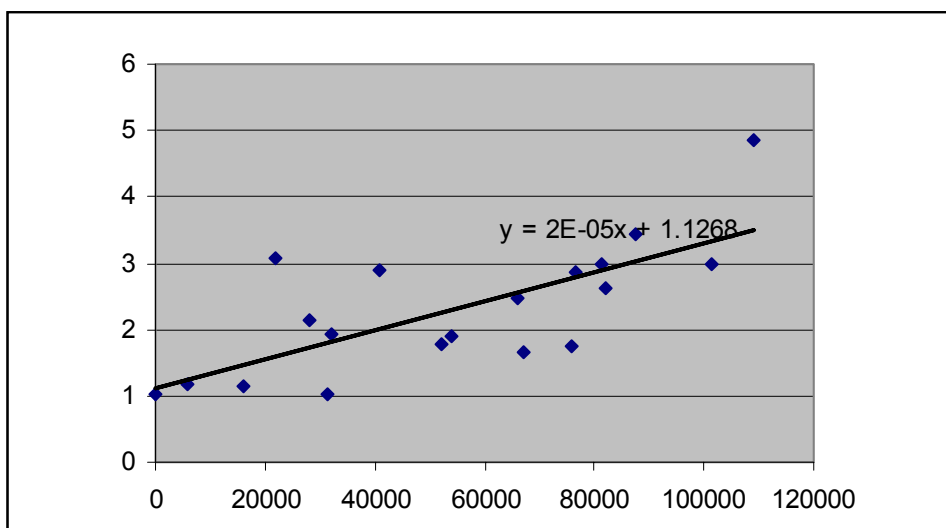

**Figure 35b: Relationship between the mean veiling glare luminance and exposure mileage for windscreen sample with outliers removed**

The data in Figure 35a indicates that as mileage increases so does the level of veiling glare luminance caused by abrasion. A linear relationship between these variables is broadly defined by the line of best fit for this sample which is plotted on the graph. It can be observed that four windscreens between 50,000 and 90,000 miles lie well above the line of best fit. Outliers, such as these, which show greater than expected abrasion may be caused by factors such as ungaraged



parking, predominant use on fast moving roads, predominant use in industrial/construction areas, etc.

Figure 35b shows the same data with the outliers excluded. The line of best fit shows that for every 10,000 miles there is an increase of 0.2cd/m<sup>2</sup> in veiling glare luminance.

### 11.3 Conclusions

From a random sample of 24 vehicles with exposure mileage ranging from 10 to just over 100,000 miles, a relationship between mileage and the veiling glare luminance caused by abrasion has been established. Using this data the mean veiling glare luminance for any vehicle can be estimated based on its mileage, assuming that the windscreen is original.

From the threshold veiling glare work programme (refer to Appendix 7) it was concluded that for windscreens of 75% luminous transmission the threshold veiling glare luminance occurred at 5cd/m<sup>2</sup>. Using the equation for the best fit line shown in figure 34b,  $y=0.00002x+1.1268$ , it can be estimated that a windscreen would need to have been used in the order of 193,660 miles for sufficient abrasion to occur to cause the non-detection of objects on the road in night-time conditions without streetlighting. If installed luminous transmission of 65% which equates to a threshold veiling glare luminance of 3.33cd/m<sup>2</sup> is used, the resultant mileage is 110,160.

### 11.4 Recommendations

Based on the worst case condition of night-time ambient lighting without streetlights, the veiling glare luminance caused by abrasion would be sufficient to cause the non-detection of targets in the road at:

- 194,000 miles based on 75% luminous transmission,
- 110,000 miles based on 65% luminous transmission (the typical installed luminous transmission of a 75% screen).

Since installed luminous transmission is more representative of the conditions under which drivers drive, the results would recommend that windscreens should be reviewed for replacement at least every 110,000 miles.

Whilst this work programme has developed a reliable methodology to relate abrasion to detection thresholds and thereby define windscreen replacement rates, it would be prudent to increase, not only the sample size of windscreens, but the number of sample areas in order to ensure a representative mix. Typical sample areas may include: the Southeast, M1/M6 corridors, Wales, major cities, coastal regions, Scottish Highlands, etc. In addition it may also be beneficial to control for different types of usage.



## **12.0 Windscreen internal contamination trials**

An additional source of visual degradation when driving is a greasy layer/film that builds up on the interior surface of a windscreen. This layer has been attributed to a number of contamination sources including atmospheric pollution drawn in when demisting or ventilating, internal pollution from smoking and food and in the earlier years of a vehicles life from particles given off from interior trim plastics under strong sunlight.

This survey aimed to measure the rate at which this film builds up and its effect on quality of driver vision in terms of light scatter and subsequent increased veiling glare luminance.

### **12.1. Methodology**

The internal and external surfaces of four, installed car windscreens were thoroughly cleaned and the vehicle's mileage recorded. Using a method similar to that used for the windscreen abrasion trials previously described, the mean luminance of the veiling glare around a shielding disc was measured. Subsequent luminance readings were taken at regular intervals at which time only the external surface of the windscreen was cleaned. In this way, the rate at which contamination film built up on the internal surface of the windscreen could be calculated in terms of increasing veiling glare luminance. Refer to figure 18.

A description of the vehicles used in this work is given in Table 34 below.

**Table 35: Description of vehicles used in the trial**

| Vehicle No. | 1  | 2  | 3   | 4  |
|-------------|--|--|---|--|
| Type        | Skoda Felicia  | Fiat Punto   | Renault Scenic  | Nissan Sunny   |
| Age         | T (1999)   | R (1997-98)  | R (1997-98)   | G (1989-90)  |
| Use Week    | Daily commute<br>≈ 30 miles on rural A and B-roads   | Daily commute<br>≈ 30 miles on rural B-roads         | Daily commute<br>≈ 60 miles on motorway   | Daily commute<br>≈ 5 miles on urban B-roads  |
| Week-end    | Rural A and B-roads and some town driving ≈ 50 miles | Generally local journeys on A and B roads ≈ 50 miles | Generally local journeys on A and B roads ≈ 50 miles<br>Occasionally long distance journeys ≈ 300 miles on motorway | Some local journeys on A and B roads ≈ 15 miles<br>Frequent long distance journeys ≈ 200 miles on motorways and major A-roads. |
| Vent use    | Occasional to screen                                 | Infrequent to screen                                 | Occasional to screen  | Occasional to screen   |
| Other       | Smoking  | No smoking   | No smoking  | No smoking   |

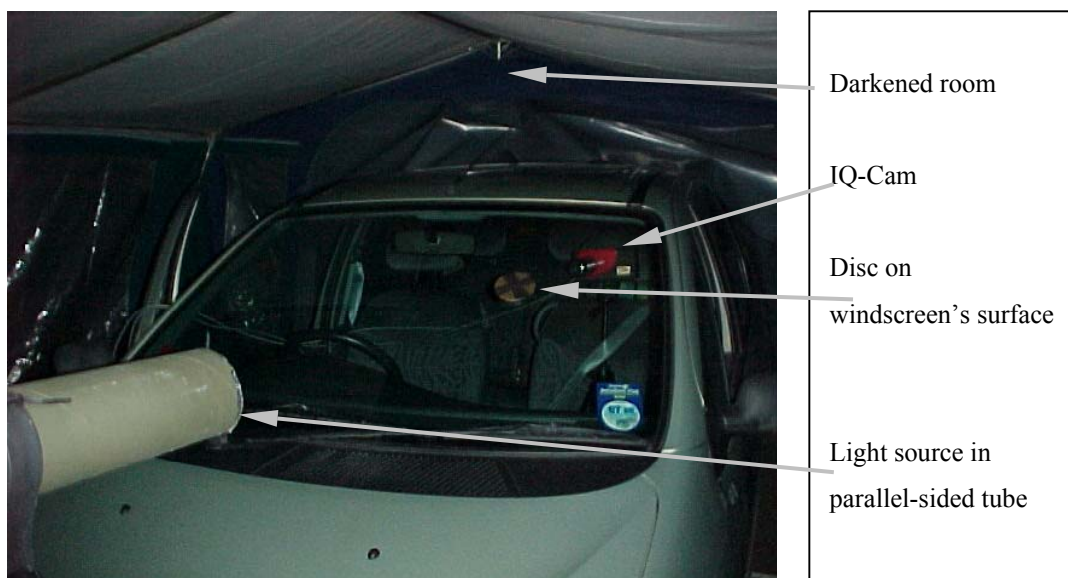
**Figure 36: Test apparatus used to measure veiling glare luminance**

From data obtained during the windscreen abrasion survey, the internal contamination luminance readings were corrected to remove the effect of abrasion.

## **12.2. Results/Findings**

The graphs on the following pages show mean veiling glare luminance for each of the four vehicle windscreens plotted against the vehicle's mileage at the time of the measurement. The luminance values have been corrected to remove the probable effect due to abrasion at the given mileage. (The correction factor is based upon the initial measurement and the relationship established from the abrasion survey previously reported). The graphs are accompanied by IQ-Cam images that illustrate the increasing amount of light scatter due to the combination of abrasion and internal contamination build up. Under each image is the mileage and time interval since the initial, 'no internal contamination' reading.

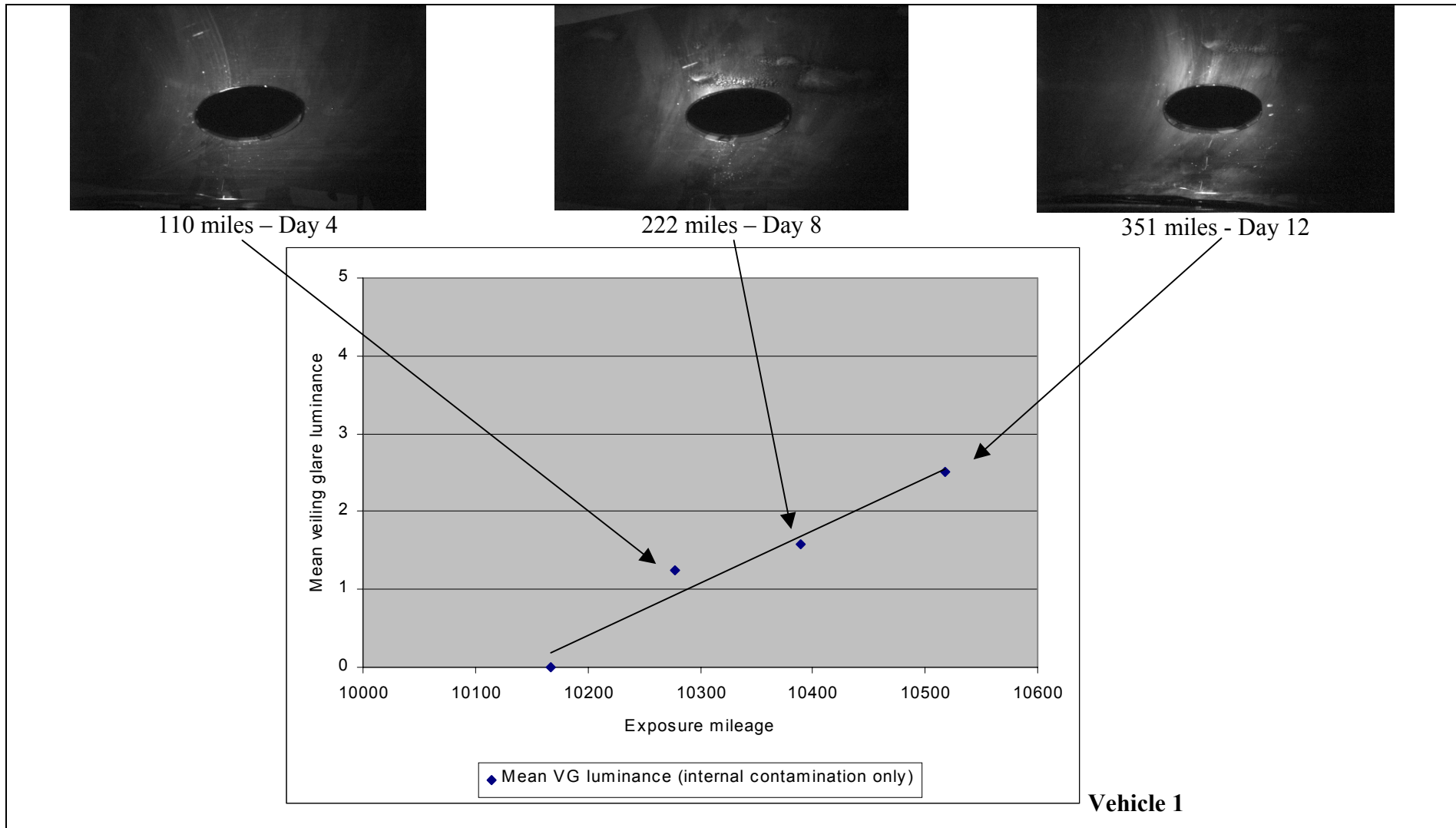

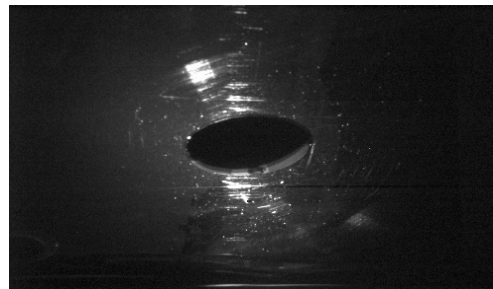

72 miles - Day 3

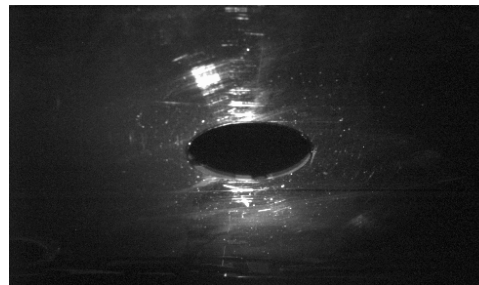

490 miles - Day 10

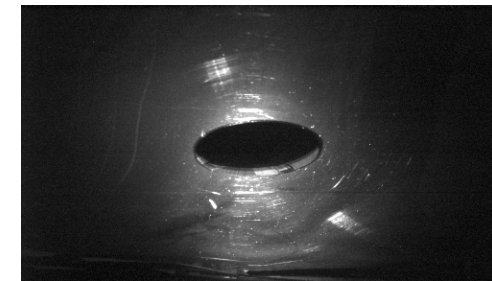

910 miles - Day 24

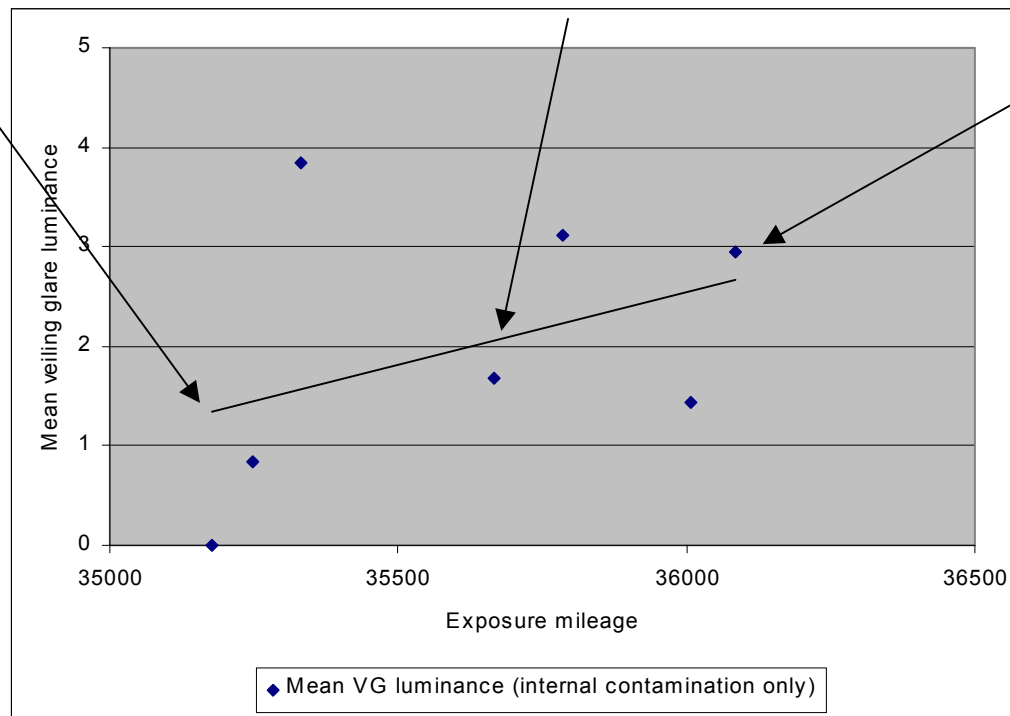

Vehicle 2



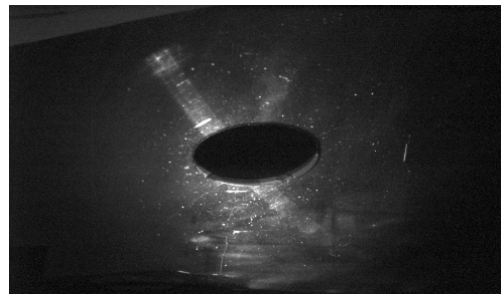

642 miles – Day 5

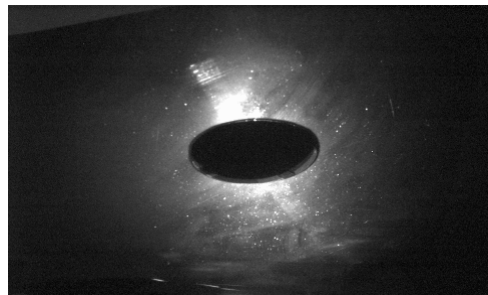

1100 miles - Day 12

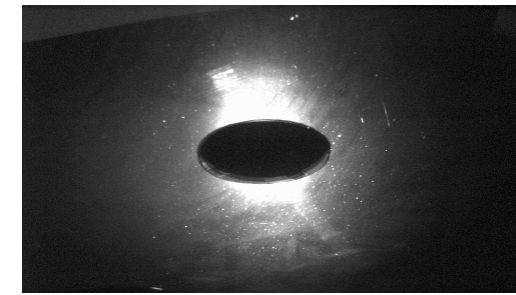

1725 miles - Day 22

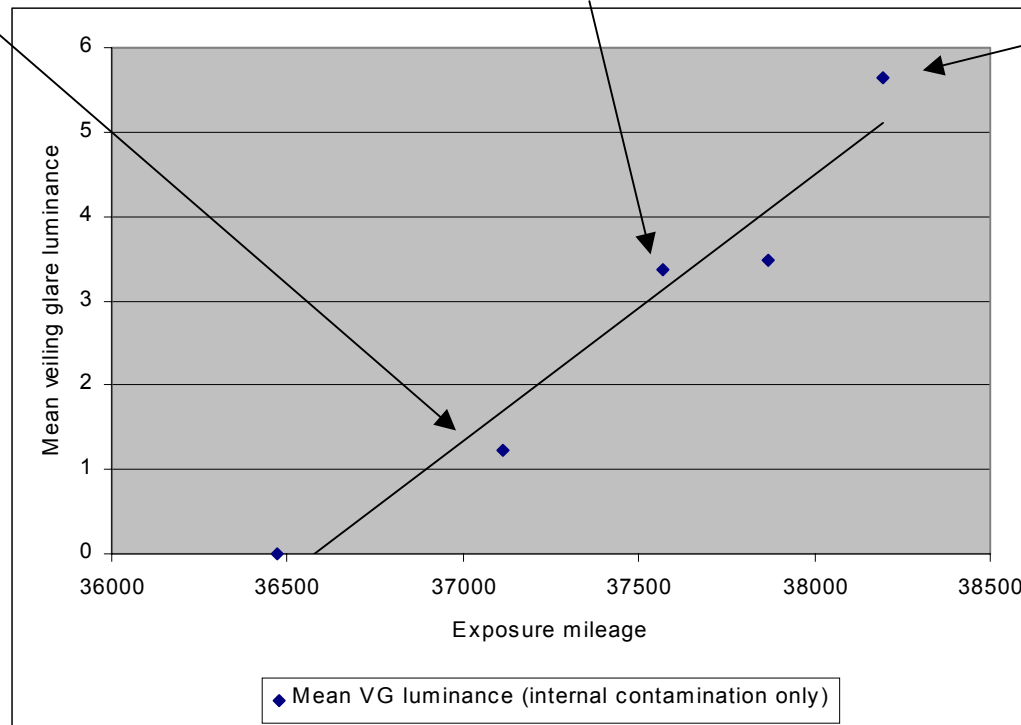

Vehicle 3

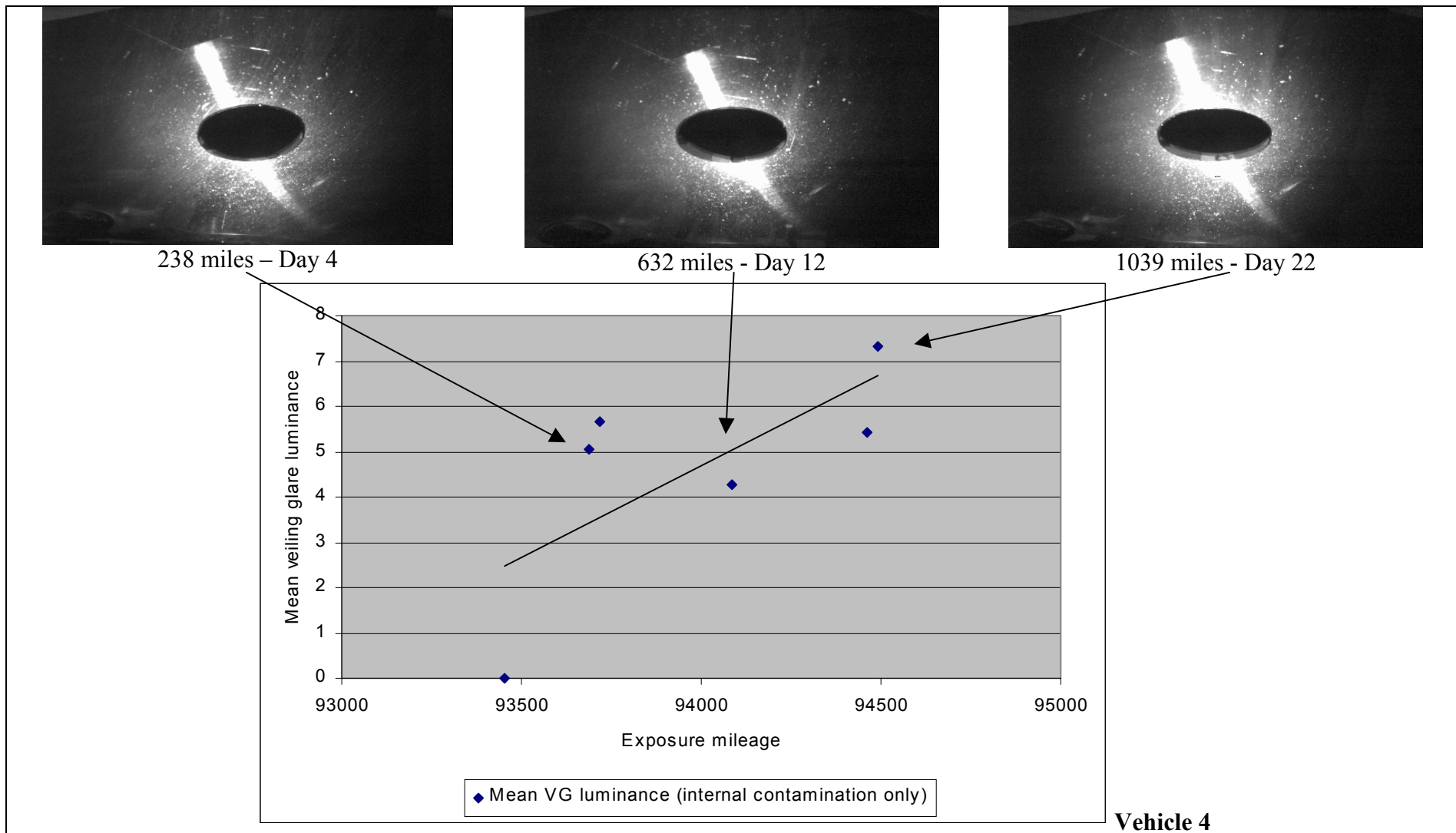



**Table 36: Windscreen internal contamination survey**

|           | Mileage covered during survey | Duration of survey (days) | Veiling glare luminance increase over survey period ( $\text{cd/m}^2$ ) | Veiling glare luminance increase per 1000miles ( $\text{cd/m}^2$ ) | Veiling glare luminance increase per month ( $\text{cd/m}^2$ ) |
|-----------|-------------------------------|---------------------------|---|--|--|
| Vehicle 1 | 351                           | 12                        | 2.35  | 6.7  | 5.9  |
| Vehicle 2 | 910                           | 22                        | 1.37  | 1.5  | 1.8  |
| Vehicle 3 | 1725                          | 22                        | 5.52  | 3.2  | 7.5  |
| Vehicle 4 | 1039                          | 22                        | 4.26  | 4.1  | 5.8  |
|           |                               |                           | Average   | 3.88   | 5.25   |

The previous figures and Table 36 above indicate that as mileage exposure increases so does internal contamination. The different rates of contamination build-up reflect different journey patterns, different use of venting systems, different driver/passenger behaviours (eating, smoking,), etc.

Based on the sample of cars used in this work, an average increase of  $3.875\text{cd/m}^2$  of veiling glare luminance occurs with every 1,000 miles travelled or  $5.25\text{cd/m}^2$  every month.

### 12.3. Conclusions and recommendations

Based on the worst case condition of night-time ambient lighting without streetlights, the veiling glare luminance caused by contamination build-up would cause targets in the road to be at the threshold of detection at the following levels. The threshold detection levels of  $5\text{cd/m}^2$  for 75% luminous transmission and  $3.33\text{cd/m}^2$  for 65% luminous transmission were derived from the veiling glare luminance trials reported in Appendix 7.

**Table 37: Recommended windscreen cleaning rates**

| Luminous transmission                                    | Level of contamination build-up at which targets are not detected |                   |
|--|---|-------------------|
|  | Miles   | Days              |
| 75%  | 1290 <sup>(1)</sup>   | 28 <sup>(2)</sup> |
| 65%<br>(Installed luminous transmission of a 75% screen) | 859 <sup>(1)</sup>  | 19 <sup>(2)</sup> |

<sup>(1)</sup> The average (mean) veiling glare luminance in the windscreen contamination survey was found to be 3.88cd/m<sup>2</sup> per 1,000 miles. (Refer to previous table). From the veiling glare trials it was found that at 75% transmission, veiling glare reached the threshold at 5cd/m<sup>2</sup>. Therefore veiling glare due to contamination will reach the 5cd/m<sup>2</sup> threshold at 1,290 miles i.e.  $(5\text{cd/m}^2 / 3.88\text{cd/m}^2) \times 1,000$  miles. At 65% transmission this equates to 859 miles i.e.  $(3.33\text{cd/m}^2 / 3.88\text{cd/m}^2) \times 1,000$  miles.

<sup>(2)</sup> The average (mean) veiling glare luminance in the windscreen contamination survey was found to be 5.25cd/m<sup>2</sup> per month. (Refer to previous table). From the veiling glare trials it was found that at 75% transmission, veiling glare reached the threshold at 5cd/m<sup>2</sup>. Therefore veiling glare due to contamination will reach the 5cd/m<sup>2</sup> threshold at 28 days i.e.  $(5\text{cd/m}^2 / 5.25\text{cd/m}^2) \times 30$  days (one month). At 65% transmission this equates to 19 days i.e.  $(3.33\text{cd/m}^2 / 5.25\text{cd/m}^2) \times 30$  days.

Since installed luminous transmission is more representative of the conditions under which drivers drive, the results would recommend that the interior of windscreens should be cleaned at least every 859 miles or 19 days.

Whilst this work programme has developed a reliable methodology to relate contamination build-up to detection thresholds and thereby define the cleaning rates for windscreen interiors, it would be prudent to undertake future research to increase, not only the sample size of windscreens, but also the number of sample areas to ensure a representative mix.

### 13.0 Colour identification trials

The aim of this trial was to determine the extent to which coloured lights, typical of those found in the road environment, could be correctly identified when viewed through windscreens of various specifications.

#### 13.1 Methodology

##### 13.1.1 Equipment

The model road was set up to simulate a daytime environment. The purpose of this was to provide a low contrast background for the lights (i.e. worst case scenario). Seven light sources of various colours were used to carry out the evaluation and were viewed through materials with different luminous transmission properties (six in all, plus one “no material” condition). The lights used were sourced from actual lights found in a typical road environment. The luminous transmission properties and light sources used in the trial are displayed below in Table 38.

**Table 38: Experimental variables**

|                               | Variables  |
|-------------------------------|--|
| Materials to view through (7) | Luminous transmission: 100% (no material), 74.5%, 51%, 33.4%, 19.6%,<br>Colour: Blue, Green  |
| Light sources (7)             | Red traffic light<br>Amber traffic light<br>Green traffic light<br>Blue vehicle beacon<br>Green vehicle beacon<br>Amber vehicle indicator<br>Red vehicle brake light |

### **13.1.2 Procedure**

The participant was seated at the end of the model road and the view of the road ahead obscured. The first test material and the first target light were put into place and, once the participant was ready, the shutter was dropped to reveal a 200 millisecond glimpse of the road scene and the light on display. The participant was asked to identify the colour of the light seen through the aperture and the data was recorded. This procedure was carried out for all lights. Once all lights had been displayed to the participant, the next test material was assessed by displaying the same seven target lights in a random order. This was repeated for all six test materials plus the “no material” condition.

### **13.1.3 Participants**

Twenty, current UK driving licence holding participants (7 male and 13 female) with a mean age of 44 years (SD 16.3) were recruited from ICE Ergonomic's database of over 400 subjects. Prior to taking part in the trial, all participants were required to carry out a test to identify any colour vision deficiencies they may have had, using the Ishihara test for colour blindness (Ishihara, 1978). No participants were found to have any form of colour blindness.

## **13.2 Results**

Table 39 summarises the data collected from the trials.

Tables 39(a) to 39(d) The responses given by 20 participants for each of the seven lights when viewed through each test material.

*(a) Red traffic light and brake light*

| Test material | Red Traffic Light |        | Red brake light |        |       |
|---------------|-------------------|--------|-----------------|--------|-------|
|               | Red               | Orange | Red             | Orange | Amber |
| 100%          | 20                | 0      | 20              | 0      | 0     |
| 74.5%         | 20                | 0      | 20              | 0      | 0     |
| 51%           | 20                | 0      | 19              | 0      | 1     |
| 33.4%         | 20                | 0      | 20              | 0      | 0     |
| 19.6%         | 20                | 0      | 19              | 1      | 0     |
| Blue          | 20                | 0      | 19              | 0      | 1     |
| Green         | 19                | 1      | 20              | 0      | 0     |

*(b) Blue beacon*

| Test material | Blue beacon |
|---------------|-------------|
| 100%          | 20          |
| 74.5%         | 20          |
| 51%           | 20          |
| 33.4%         | 20          |
| 19.6%         | 20          |
| Blue          | 20          |
| Green         | 20          |

*(c) Amber traffic light and indicator*

| Test material | Amber Traffic Light |        |        |      | Amber indicator |        |        |      |
|---------------|---------------------|--------|--------|------|-----------------|--------|--------|------|
|               | Amber               | Yellow | Orange | Gold | Amber           | Yellow | Orange | Gold |
| 100%          | 8                   | 8      | 3      | 1    | 8               | 8      | 3      | 1    |
| 74.5%         | 8                   | 8      | 3      | 1    | 8               | 8      | 3      | 1    |
| 51%           | 8                   | 8      | 3      | 1    | 8               | 8      | 3      | 1    |
| 33.4%         | 8                   | 8      | 3      | 1    | 8               | 8      | 3      | 1    |
| 19.6%         | 6                   | 10     | 3      | 1    | 7               | 9      | 3      | 1    |
| Blue          | 7                   | 9      | 3      | 1    | 7               | 9      | 3      | 1    |
| Green         | 8                   | 9      | 2      | 1    | 8               | 9      | 2      | 1    |

*(d) Green traffic light and beacon*

| Test material | Green Traffic Light |            |      |          |           | Green beacon |
|---------------|---------------------|------------|------|----------|-----------|--------------|
|               | Green               | Blue/Green | Blue | Sea Blue | Turquoise | Green        |
| 100%          | 15                  | 0          | 3    | 1        | 1         | 20           |
| 74.5%         | 12                  | 1          | 4    | 1        | 2         | 20           |
| 51%           | 14                  | 1          | 3    | 1        | 1         | 20           |
| 33.4%         | 14                  | 0          | 4    | 1        | 1         | 20           |
| 19.6%         | 13                  | 1          | 5    | 1        | 0         | 20           |
| Blue          | 13                  | 2          | 3    | 1        | 1         | 20           |
| Green         | 15                  | 1          | 3    | 0        | 1         | 20           |

### 13.2.1 Red lights

The four occasions where red was seen as amber or orange, through 19.6% and 51% transmission levels and blue and green tints, were not found to be statistically significant. In other words, the identification of the red lights were found not to be affected when viewed through materials with reduced transmission levels or with green and blue tints.



### **13.2.2 Blue lights**

The results show that all participants saw the blue beacon as blue through all of the test materials. Therefore viewing the colour blue was not found to be affected by transmission level or tint colour.

### **13.2.3 Amber lights**

Only eight of the participants reported seeing the traffic light and the vehicle indicator as amber. However since this occurred when viewing directly and the colours reported by the remaining participants were all in the same area of the colour spectrum, it is suggested that this is not a real effect but one of semantics.

Approximately a quarter of the participants reported seeing a different colour under certain transmission levels and tint colours, although these differences were within the amber region of the colour spectrum and were not found to be statistically significant.

### **13.2.4 Green lights**

Whilst the green beacon was always reported as green, the green traffic light was reported as a variation in the green to blue colour spectrum by a quarter of the participants when viewing directly.

## **13.3 Conclusion**

The results of this experimental study indicate that the transmission levels and blue and green tints used in this work do not significantly affect the ability to identify and distinguish red, amber, blue or green lights typical of those found in the road environment.

## **14.0 Discussion and recommendations**

### **14.1. Driver and rider surveys**

The driver and rider surveys concerning the quality of vision through windscreens and visors confirmed and prioritised the importance of windscreen/visor tinting, installed light transmission, haze, abrasion and damage/repair to driver/rider vision.

These surveys indicated that glare was a problem for both drivers (20/29) and riders (35/42) and, in conjunction with a survey of visor usage, it was found that the use of tinted visors at night was relatively high. 20/42 in the rider survey admitted to having done this in the past and 20/20 of those with visors with less than 80% transmission stated that they would be using them to ride home at dusk or later, on that day.

### **14.2. Experimental trials - Laboratory and field**

An initial laboratory study using the model road was undertaken to investigate a wide range of ambient conditions in order to identify those pertinent to further investigation.

A second laboratory study was then undertaken based on the recommendations from a peer review amongst relevant experts in road user vision and on the findings from the initial laboratory study.

The results of both sets of model road trials were discussed with the peer group members and an experimental methodology was developed for the field trials. The aim was to determine the extent to which the findings of the laboratory trials could be verified in the real world.

A summary of the significant findings of these trials is given in the table below.

|  | No significant difference between transmission levels of ... | Significant difference between transmission levels of ... | Range for lower limit to luminous transmission |
|--|--|---|--|
| Initial laboratory study (Dusk)              | 74.5% and 33.4%  | 74.5% and 19.6%   | 33.4% and 19.6%                                |
| Second laboratory study (Night-time + glare) | 74.5% and 45.3%  | 74.5% and 33.4%   | 45.3% and 33.4%                                |
| Field study (Dusk)                           | 80% and 47%  | 80% and 28%   | 47% and 28%                                    |

**Table 40: Significant findings of the experimental trials**

### 14.3. Expert appraisal of visor alternatives

An expert appraisal was undertaken to investigate the alternatives available to reducing glare. The results of this appraisal indicated that only the two-stage, 50%, iridium and mirror insert visors as well as the clear visor with a peak reduced discomfort glare from unacceptable to just acceptable levels. However, aside from the peak (which did not provide benefit against glare from high levels of ambient illumination), these alternatives if used at night on lit roads gave rise to shorter detection distances than the clear visor. Since the rider surveys indicate a high proportion of riders will choose to use inappropriately tinted visors under dusk and night-time conditions, this is an important aspect to consider in weighing the relative benefits of detection distance against reduced discomfort glare.

The best option appeared to be the use of a photochromatic visor which would automatically adjust its transmission level to suit the current ambient condition. However whilst such a product is under development, many aspects relating to its design need to be addressed and so this will not provide an immediate solution. A polarised visor may also offer some benefits and should be investigated subject to availability.

Graduated visors were not favoured since, in the expert appraisal, it was considered that they were easy to misuse i.e. it was likely that riders may unintentionally view through a part of the visor inappropriately tinted for the conditions. The visor with the shade band and the two-stage visor (a visor with an

integral dark visor which could be raised and lowered as required by the rider) were considered to be less subject to misuse but could still be abused i.e. deliberately used inappropriately.

#### **14.4. Abrasion survey**

The abrasion levels of twenty four originally fitted windscreens were measured in terms of veiling glare luminance and cross-referenced with the vehicle mileage. The work indicated that the level at which veiling glare luminance would be sufficient to cause the non-detection of targets in the road was likely to occur at:

- 194,000 miles based on 75% luminous transmission,
- 110,000 miles based on 65% luminous transmission (the typical installed luminous transmission of a 75% screen).

#### **14.5. Contamination survey**

The luminous transmission levels of four windscreens which were cleaned internally and externally were measured in terms of their veiling glare luminance. Over a month the internal contamination of the screen was allowed to build-up and measurements were made and compared to the initial readings. The work indicated that the level at which veiling glare luminance would be sufficient to cause the non-detection of targets in the road was likely to occur at:

- 1290 miles / 28 days build-up based on 75% luminous transmission,
- 859 miles / 19 days build-up based on 65% luminous transmission (the typical installed luminous transmission of a 75% screen).

#### **14.6. Recommendations**

##### **14.6.1. Luminous transmission**

###### ***Riders***

Although discomfort glare is likely to be reduced at lower transmission levels, the reduced ability to detect targets when such visors are misused under darkened conditions must be the priority consideration. The lowest limit for luminous

transmission must be the lowest transmission level which does not significantly differ from a clear visor in terms of detection. Based on the work undertaken to date in the course of this project, as summarised in the table above, it is recommended that a lower level for luminous transmission for visors which might be used at night be set in the order of 47% to 33.4%. (In light of these findings, it may be prudent to re-visit the regulations relating to sunglasses).

The conflict of night-time daytime trade-offs as described above may be eliminated in the future through the use of a photochromatic visor which is currently under development, or possibly by a polarised visor. Of the currently available alternatives, a peak offers some benefit against direct glare sources such as a low sun, whilst a two-stage visor offers benefit against high ambient illumination in terms of comfort but would reduce detection distances if misused at night.

### ***Drivers***

With respect to drivers a further consideration needs to be made which relates to installed light transmission. A recent study conducted by ICE Ergonomics (Quigley et al 2000) found that windscreens were typically installed into vehicles at an angle of 59°. Looking through windscreens at such angles increases luminous transmittance losses due to reflection and absorption compared to windscreens viewed vertically at 0°. Previous research (Smith and Bryant, Hills) indicates that luminous transmission is reduced by approximately 10% between 0° and 59°.

#### **14.6.2. Abrasion and contamination**

With respect to abrasion and contamination, ICE Ergonomics developed valid and reliable methods to measure and reproduce their effects. These methods were based on the veiling glare luminance caused by the light scatter resulting from different levels of abrasion and contamination. The results of this work confirmed that the effects of abrasion and contamination are most severe at night and this was used as the basis of the following recommendations. It was considered important for this study to concentrate on these aspects since, unlike screen

damage, drivers may be unaware that they are driving with impaired vision and have no formal guidelines to assist them in determining this.

### ***Abrasion***

Based on our sample vehicles, windscreens should be replaced every 110,000 miles due to the detrimental effects of abrasion.

### ***Contamination***

In addition to keeping the outside of the windscreen clean, the inside should also be cleaned. Based on our sample, windscreen interiors should be cleaned at least every 859 miles or 19 days. Comparison with the results of the drivers' survey indicates that at least 6 (23%) and possibly as many as 19 (73%) from 26 drivers do not clean the interior of their screen this frequently. Since contamination build-up accumulates gradually over time, drivers may not always be aware that they are driving with impaired vision and since no formal screen clean guidelines exist, it was important to fully address this aspect of the study.

The above two recommendations provide the initial basis for guidelines which currently do not exist. However to increase their representativeness, consideration should be given to carrying out further research. Refer to the next section for details of this.

#### **14.6.3. Reflection**

A further recommendation from this work, based on the drivers survey, is that windscreen reflection is an area which should also be considered for future investigation. Previous research conducted by Allen et al 1996 recommends improving contrast and reducing glare by covering the vehicles dash with a dull black cloth. Removing objects from the dash which reduce contrast should also be encouraged.

**14.6.4. Fogging**

A survey carried out by the Health and Safety Executive (HSE) found that fogging was the main reason why eye protectors were not being used when needed. (This supports the finding from the survey of riders conducted as part of this study which found that ‘misting’ was a problem associated with visor use). A method which could be used to measure the amount of time it took for the clarity of a viewed image to be reduced to 50% and 75% of its original value was devised by Vaughan et al (undated) in response to the HSE survey. Further investigation should be made to determine if this could form the basis of a future test for motorcycle visors for reduced clarity due to fogging.

## **15.0 Future work**

The work undertaken in this study has indicated areas requiring further research; these are given below.

### **15.1 Luminous transmission**

It would be beneficial to assess the performance of photochromatic visors when such become available to determine the benefits/disbenefits which they may offer. The performance of these visors should also be assessed against alternatives available at that time. Polarised visors should be similarly assessed.

### **15.2 Abrasion and contamination**

Whilst this work programme has developed a reliable methodology to relate abrasion and contamination levels to detection thresholds and thereby define windscreen replacement and cleaning rates (refer to the sections relating to the windscreen abrasion and contamination trials), it would be prudent to increase not only the sample size of windscreens but the number of sample areas to ensure a representative mix. Typical sample areas may include: the southeast, M1/M6 corridors, Wales, major cities, coastal regions, Scottish Highlands, etc. In addition it may also be beneficial to control for different types of usage.

### **15.3 Reflection**

Since there is little existing research concerning the effect of reflections, it would be valuable to investigate this area further. This was an area of particular concern for the respondents in our driver survey with 26 from 36 respondents stating that they had experienced problems due to reflections on the windscreen. Future research should identify the sources of reflection, quantify their effects in terms of veiling glare and target detection, investigate solutions and provide guidelines to vehicle manufacturers and users as to how to reduce the disbenefits of reflections.



#### **15.4 Fogging**

Further research is required to quantify the effect of fogging which has been identified by two independent bodies (the Health and Safety Executive and ICE Ergonomics as part of this study) as an impediment to visor use. Based on ICE's working concerning veiling glare threshold levels and the work of Vaughan et al (undated) which measures the amount of time taken for the clarity of a viewed image to be reduced to 50% and 75%, much of the research and development of relevant evaluation methodologies appears to be in place for future research.

The drivers' survey indicated that one third of drivers use the car's fan to clear the windscreen *while driving*. Acceptable minimum levels to which the screen must be demisted in the shortest possible time, and the windscreen areas to which this should be applied, should be investigated.

#### **15.5 Additional considerations**

Additional consideration regarding motorcycle helmet and visor design are given in Appendix 9. These result from communication within the project with Stephen Prower's of the BMF and include aspects such as misting, visor retention, aerodynamics, hearing loss, ventilation and screen interactions,

## 16.1 References

| AUTHOR                        | TITLE  | DATE | JOURNAL/SOURCE                             | PUBLISHER                           |
|-------------------------------|--|------|--|-------------------------------------|
| Alferdinck, J and Theeuwes, J | The relation between discomfort glare and driving behaviour  | 1995 | Progress in Automobile Lighting (PAL) 1997 | Darmstadt University of Technology  |
| Allen et al                   | Forensic aspects of vision and highway safety  | 1996 |  | Lawyers & Judges Publishing Co, Inc |
| Allen, M J                    | Windscreen dirt and surface damage effects   | 1974 | Australian Road Research Vol. 5, No. 6     |                                     |
| Bhise, V D                    | Visual search by drivers in freeway merging: implications for vehicle design   |      |  |                                     |
| Burns, N.R. et al             | Effects of car window tinting on visual performance: a comparison of elderly and young drivers   | 1999 | Ergonomics, Vol 42, No.3, 428-443          |                                     |
| Charman, W N                  | Vision and Driving   | 1997 | Road Safety Research Report No. 2          | The Department of Transport         |
| Chauhan K and Charman N       | The Mandelbaum effect and night driving  |      | Report and papers for Link-TIO             | UMIST                               |
| Chmielarz, M et al            | Vision-impairing wear of windshields   | 1988 |  |                                     |
| Chong, J et al                | Visual Accommodation and target detection in the vicinity of a window post 1989  | 1989 | Human Factors, 31(1), pp 63 - 75           | The Human Factors Society           |
| Clark, B A J                  | Visual handicaps allowed by road vehicle standards   | 1996 |  | Defence Science & Tech Org.         |
| Clark, B A J                  | Day-time hazards of windshield tinting   | 1993 | Road & Transport Research                  |                                     |
| Cooper, B R                   | Night-time seeing distances with tinted motorcycle helmet visors   | 1983 | Working Paper                              | TRRL                                |
| Cunningham, g                 | After-market-film on passenger car windows and light transmission  | 1993 | Vision in Vehicles                         | Elsevier Science Limited            |
| Dain, SJ                      | Review of the visual issues related to tinted side automotive windows  | 1997 | Pentagon Auto-Tint                         | University of New South Wales       |
| Department of Transport       | Proposed Manual on Motorcycle riding   | 1981 |  | TRRL                                |
| Derkum, H                     | Effects of various transmission levels in windshields on perception  | 1994 | Vision in Vehicles                         | Elsevier Science Limited            |
| Enright A                     | Same is more: Audi's A4  | 1999 | Article                                    | The Times                           |
| Fosberry RAC and Mills BC     | Measurements of the driver's visibility from private cars and commercial vehicles and some recommendations for minimum visibility requirements | 1956 | MIRA                                       |                                     |

| AUTHOR                        | TITLE   | DATE | JOURNAL/SOURCE  | PUBLISHER                                   |
|-------------------------------|---|------|---|---|
| Fowkes, M                     | The legislative determination of the drivers field of view  | 1986 | Vision in Vehicles  | Elsevier Science Limited                    |
| Gittelsohn A M                | Tinted windshields don't increase accident risk   | 1973 | Automotive Engineering                                    |   |
| Green P and Burgess WT        | Windshield Damage and Driving Safety  | 1981 | Final Report  | The University of Michigan                  |
| Haase, O et al                | Vision impairment by worn windshields during night-time driving                                   |      |   |   |
| Haslegrave, C.M.              | Visual aspects in vehicle design  |      | Automotive Ergonomics - Peacock and Karwowski             |   |
| Hayward J M & Marsh R J       | Visual field restriction caused by motor cycle helmets  | 1988 | Vision in Vehicles II eds. A. G. Gale et al               | Elsevier Science Limited                    |
| Helmers, G and Lundkvist S-O  | Detection distances to obstacles on the road seem through windscreens in different states of wear | 1988 | VTI rapport   | Swedish Road and Traffic Research Institute |
| Hills, B                      | Tinted Windshields: Effects on visibility, thermal comfort and accident rates                     | 1976 |   | TRRL  |
| Ishihara, S.                  | Tests For Colour Blindness. 38 plates edition.  | 1978 |   | Kanehara Shuppan Co., Ltd, Tokyo.           |
| Kessler, F R                  | Light diffusion characteristics and visibility interferences in automobile windshields            | 1993 | Vision in Vehicles - IV eds. A. G. Gale et al             | Elsevier Science Limited                    |
| Khalid, H M & Ooi, P C        | Effects of motorcycle helmets on task performance and user acceptability                          | 1996 | Vision in Vehicles - V eds. A.G. Gale et al               | Elsevier Science Limited                    |
| Klein, R.                     | Age-related eye disease, visual impairment, and driving in the elderly                            | 1991 | Human Factors 33(5), pp 521 - 525                         | The Human Factors Society                   |
| McKnight, A J & McKnight, A S | The effects of motorcycle helmets upon seeing and hearing   | 1994 | Accident Analysis and Prevention, Vol.27, No.4, pp493-501 | Elsevier Science Limited                    |
| McLean, A J et al             | Adelaide in-depth accident study 1975 - 1979  | 1979 |   | The University of Adelaide                  |
| Morris, A et al               | Visual acuity of the US navy jet pilot and the use of the helmet sun visor                        | 1991 | Aviation, Space and Environmental Medicine                | Aerospace Medical Association               |
| Mukherjee, P                  | Car Window Tinting - a Consultative Document  | 1997 | Supplement  |   |
| Narisada, K                   | Perception in complex fields under road lighting conditions                                       | 1995 | Lighting Res. Technol. 27(3) 123-131                      |   |
| Olson, P.L.                   | Visibility problems in night-time driving   | 1987 | SAE Technical Papers                                      | SAE   |
| Olson, P.L. et al             | Performance requirements for large truck conspicuity enhancements                                 | 1992 | DOT HS 8-7 815 Final report                               | US DOT, NHTSA                               |
| Olson, P.L.                   | Forensic aspects of driver perception and response  | 1996 |   | Lawyers & Judges                            |

| AUTHOR                     | TITLE  | DATE | JOURNAL/SOURCE   | PUBLISHER                             |
|----------------------------|--|------|--|---------------------------------------|
|                            |  |      |  | Publishing Co, Inc                    |
| Phillips, A J & Rutstein A | Glare - A study into glare recovery time with night driving spectacles   | 1965 | The British Journal of Physiological Optics Vol. 22, No. 3 | British Optical Association           |
| Porter, J M & Stearn, M C  | A technique for the comparative assessment of external visibility characteristics in road vehicles                                   | 1986 | Vision in Vehicles   | Elsevier Science Limited              |
| Proffitt, D.R. et al       | The effect of reduced transmittance window tinting on drivers' ability to detect targets in their rear-view mirrors                  | 1996 |  | Virginia department of transportation |
| Quigley et al              | Field of vision (A-pillar geometry) – A review of the needs of drivers. Final report.  | 2000 | Report for DETR  |                                       |
| Rompe K & Engel G.         | The influence of windshields with low light transmission in driver's vision  | 1987 | SAE Technical Papers                                       | SAE                                   |
| RoSPA                      | Starting off   |      | Guide to Safer Motorcycling                                | RoSPA                                 |
| Sayer, J R & Traube E C    | Factors influencing visibility through motor vehicle windshields   | 1994 | US Department of Commerce NTIS                             | UMTRI                                 |
| Slade, S V and Dunne MCM   | Visual acuity, voluntary driving restriction and road crashes  | 1996 |  | Aston University                      |
| Smith, G & Bryant, JFM     | The optical properties of tilted windscreens under practical conditions  | 1978 | ARRB Proceedings Vol 9, Part 5,                            |                                       |
| Snook, S.                  | Automotive Glass   | 1998 | Engineering  |                                       |
| Taylor J F                 | Tinted glazing on vehicles   |      |  |                                       |
| Timmermann, A.             | Direct measurement of windscreen surface wear and the consequences for road safety   | 1986 | Vision in Vehicles   | Elsevier Science Limited              |
| Timmermann, A.             | Reduction in vision through used crash-helmet visors   | 1985 | Research Institute of Auto-Sicht                           | TRRL                                  |
| Timmermann, A.             | An instrument to measure scattered light due to windshield wear  |      |  |                                       |
| Unknown                    | Speed related severity of injury to motorcyclists - visors   |      |  |                                       |
| Unknown                    | The DETR Rational against a reduction in minimum light transmittance   | 1979 | BS 4110  | BSI                                   |
| Unknown                    | Through the glass darkly   | 1997 | Motor cycle Rider  |                                       |
| Unknown                    | Research Frontiers grants licence to ... to manufacture and sell .... for making variable transmission films for "smart windows" ... | 1999 | Research Frontiers   | Press Release                         |
| Vaughan, n et al           | Development of an objective method for assessing the fogging of complete eye protectors; Final report                                |      |  | EC funded project MAT1-CT 940042      |
| Waters PE                  | The effects of tinting and abrasion of motorcyclists visors on night time vision   | 1982 | BSI draft document   |                                       |

| <b>AUTHOR</b>                  | <b>TITLE</b>  | <b>DATE</b> | <b>JOURNAL/SOURCE</b>                   | <b>PUBLISHER</b>         |
|--------------------------------|---|-------------|---|--------------------------|
| Weigt, P                       | Darker glasses in the rearward field of view              | 1986        | Vision in Vehicles                      | Elsevier Science Limited |
| Wigan M R                      | Towards improved standards for automotive eye protection  | 1979        | Australian Journal of Optometry<br>62.8 |                          |
| Zwahlen, H.T. &<br>Schnell, T. | Visibility through tinted automobile windshields at night | 1994        | Ergonomics and Design, Vol 4            | IEA                      |

## WORK SPECIFICATION

### PROJECT TITLE - QUALITY AND FIELD OF VISION - A REVIEW OF THE NEEDS OF DRIVERS AND RIDERS

IFCOS reference number - S322E/VF

#### 1. INTRODUCTION

Good visibility is likely to help a driver or rider avoid crashes. Legislation which promotes and upholds the best design features is essential in setting and maintaining the best levels of safety. Such action will help reduce the level of accidents and, therefore, reduces costs associated with vehicle damage and, in the more severe cases, injury and death.

This project will investigate and define the problems associated with restricted visibility for vehicle drivers and motorcycle riders and, in turn, it shall seek to quantify and recommend the level of visibility required to support safe driving/riding.

Vision, visibility and perception in driving was last reviewed nearly 20 years ago. Since then much has changed. Market conditions have led to some improvements, but there are particular areas of concern. For drivers of light duty vehicles these include tinting, windscreen condition (including installed light transmission, haze, abrasion, damage and repair), and the use and positioning of wider structural members to improve crashworthiness, aerodynamics and rigidity. For motorcyclists these include tinted visors. These could be or become an increasing cause of accidents.

In particular, motorcycle lobby groups, the motorcycle press and the BSI committee responsible for eye protector standards have for some time been asking for a relaxation for dark tints - reducing the minimum light transmittance from 50% to 18%. This has so far been resisted. However, they have recently been joined by the police, the AA and the RAC; and a CEN standard for motorcyclists goggles permitting dark tints has been ratified with BSI support despite DETR objections.

Although, following an international undertaking, the UK is unable to change its domestic requirements on helmets and visors before 1 July 2000, DETR is expected to come under increasing pressure, both at home and abroad, to legalise dark visors as soon as possible thereafter. It is therefore necessary to revisit the rationale behind the 50% limit agreed by BSI in the early 1980s and consider how best to deal with the problems of bright sunlight without compromising safety in other conditions. This will help policy makers reach an equitable balance between the need for sun glare protection for motorcycle and moped riders and the risk to safety of inappropriate use.

The work would first review available research to determine the latest scientific knowledge and current practice in the real world, identify gaps and assess the effects of any differences between ideal, legislated and actual vision, and then, if significant, propose and cost possible means of maintaining or improving the ability of drivers/riders to see what is necessary if road safety is not to be compromised. Findings would influence future amendments to UK regulations, EC Directives, UNECE Regulations and in-service enforcement.

## **2. BACKGROUND**

### **2.1 Department of Transport**

Annex I describes the objectives and role of the Department and the Vehicle Standards and Engineering (VSE) Division and explains the vehicle type approval system.

### **2.2 European and National Regulations**

EC Directives such as 77/649/EEC (Minimum forward field of vision for drivers of passenger cars) set out minimum performance standards. The Road Vehicle (Construction and Use) Regulations 1986 (SI 1986 No 1078) lists several domestic regulations:

- Regulation 30 requires vehicles to be so designed and constructed such that the driver has at all times a "full view of the road and traffic ahead of the motor vehicle".
- Regulation 104 states that no one should drive a motor vehicle if they do not have a full view of the road ahead.

The national requirements for windscreens in the MOT and British Standards in particular BS AU 242A 1998 (Windscreen repair COP), and AU 251 1994 (Specification for performance of automotive laminated windscreen repair systems) for glazing repair should be considered.

The Motor Cycle (Eye Protector) Regulations, in particular BS 4110: 1979 (for visors and goggles), BS 4110: 1998(for visors) and EN 1938: 1998(for goggles), will require consideration.

The project will review and consider these and other relevant standards/regulations such as LJNECE Regulation 22 (protective helmets) as appropriate.

### **2.3 Project Background**

The Departments aim of providing a safe transport network has been substantially supported by research into primary safety, reducing the occurrence of accidents, and secondary safety, reducing the incidence and severity of injuries when an accident occurs. As the benefits of existing knowledge of safety systems are progressively exploited, new primary and secondary safety approaches and systems must be sought and their potential evaluated.

This project seeks to build on past research into road user vision and visibility from vehicles. Road and vehicle lighting standards have improved and materials available for vehicle windows and motorcyclists visors have also developed technically since the previous investigations by the former DOT.

### **2.4 Previous and Current Research**

Research for project S32OE/VE "Drivers field of vision in large vehicles" is ongoing at the Institute for Consumer Ergonomics (ICE) and this research is to be fully considered and used to support this project. Part of the current proposal is to perform a literature review to evaluate past and recent research from this country and abroad, including work by the Transport Research Laboratory (TRL), ICE, UMIST, Aston University, US National Highway Traffic

Safety Administration (NHTSA), Australian FORS, BSI Committee PSW2/7 when developing BS 4110: 1979 and BSI Committee PH/2/5 when developing EN 193 8:1998 and BS 4110: 1998.

## **2.5 Policy**

The results of this research will extend the Department's knowledge of, firstly the general factors governing visibility for vehicle drivers and riders, secondly factors relevant to visibility for motorcycle riders and finally factors relevant to drivers of light duty vehicles. Findings would influence future amendments to UK regulations, EC Directives, UNECE Regulations and in-service enforcement.

## **3. PROJECT OBJECTIVES**

This projects objectives are to:

- i) Review the literature and any available accident data to determine what is known and what is not known about the influence of optical effects on the perception of road users and propose research to fill the gaps.
- ii) Determine the rationale for the current levels of driver and rider visibility. Consider the effects, and propose, cost, and evaluate, possible means of delivering safety benefits; by way of new requirements relating to the quality and field of vision in light duty vehicles and protective headgear.
- iii) Consider the effect of any proposals to change the current levels and enforcement methods, the adequacy of existing controls and the changes to standards and enforcement that might be necessary to deliver the safety benefits identified above.
- iv) Prepare draft documents to amend the appropriate instruments (e.g. standards, directives, and regulations) or develop codes of practice.

## **4. TASKS AND METHODOLOGY**

### **4.1 Establish the basis of the EC Directives and Other Regulations**

We want to know how the various standards that comprise the current visibility levels were justified as they form the basis of recommendations for improvements.

### **4.2 Review and summarise previous and current research and consider links with current and proposed research**

Review progress reports on Driver's field of vision in large vehicles ICE project S32OE/VE (contracted to ICE) and when underway, the forthcoming VSE conspicuity project on motorcycle coloured headlamps. Evaluate the findings of previous research to prevent duplication and re-examination of proven areas.



### **4.3 Carry out analyses of real world accident case records**

The contractor should analyse accident databases and previous research (in particular taking into account the data held by the Glasgow and TRL fatal database to establish the extent of identifiable real world visibility problems. If found, identify common accident scenarios and develop an understanding of the reasons why these accidents occur. It would be useful to link restrictive visibility directly to accidents but previous experience dictates that the link is tenuous and unlikely to produce effective results. No major effort should be directed at this task unless the contractor can suggest a novel method likely to prove linking.

### **4.4 Identify problems with existing vehicle design and regulations**

The contractor must determine whether existing European and domestic regulatory requirements are adequate and how the latest design trends would impact on legislation. Driver surveys may help to identify common visibility problems and factors which may contribute to accidents. Drivers may also have views on the merits of possible technical solutions.

### **4.5 Quantify as far as possible the following using methods to be agreed.**

#### **4.5.1 General**

- a) The relationship between light transmittance, signal recognition, seeing and stopping distances and injury severity in normal conditions, bright sunlight, low sun conditions, precipitous overcast conditions, at dawn, dusk and night time.
- b) The optimum level of light transmittance and signal recognition for i) each condition, ii) day time, iii) night time and iv) all conditions taking into account exposure and assuming v) no misuse and vi) misuse in unsuitable conditions and how these levels compare with those experienced in the real world.

#### **4.5.2 For riders**

- a) The risks of inappropriate eye protection and its role as a contributor to road traffic accidents involving motorcycle and moped riders' in particular taking into account the databases referred to in para 4.3 above.
- b) The extent and consequences of any misuse of visors and goggles in unsuitable conditions. (Currently, the only tinted visors designed for use during the daytime are those with a 50% tint but these could wrongly be used at other times when they should not.)

#### **4.5.3 For drivers**

- a) The minimum acceptable tinting levels for vehicle glazing (front, side and rear screens).
- b) The consequential risk to road safety of changes in 'A' pillar size and position, driven by the need for improved structural and aerodynamic performance which can restrict driver vision. It is likely that unknown/unappreciated blind spots are a real safety hazard.

Obvious loss of vision is expected to be compensated for by the drivers approach and positioning.

- c) The effect on vision of windscreen condition such as; haze, abrasion, damage and repair. Repairs to glazing are permissible, within limits, but are such repairs invisible to the driver or do they impair visibility especially at night or in conditions of poor visibility. Also consider the effect of installed light transmission.

#### **4.6 Research work to fill knowledge gaps**

Although a lot is known about visibility some areas may not be adequately covered by previous research and may not be listed as tasks within this work specification. The contractor is invited to point out the missing links and to cost them as options in their proposals

#### **4.7 Effects of any reduction in vision**

Consider the effect of any proposals to reduce the current levels and the adequacy of existing controls and the changes to standards and enforcement that might be necessary to realise the benefits identified above.

#### **4.8 Proposals and costing of possible new requirements relating to quality and field of vision**

##### **4.8.1 General**

Propose, cost and evaluate possible means of improving the quality and field of vision in the real world. In particular, suggest, qualify and evaluate how any safety benefits and/or disbenefits arising from optimum systems may be delivered by other means without compromising road safety.

##### **4.8.2 For riders**

Visors and goggles, opaque strips on visors, graduated tints, two stage visors, and optimising the balance between minimum tint and colour recognition and detachable peaks on helmets and visors.

##### **4.8.3 For drivers**

Field of view and whether a performance specification or a design specification would produce the desired results. Field of View should be directed at driver forward visibility (front 180 degrees without the use of mirrors). New requirements may be needed for the drivers basic field of direct vision considering likely impairment to visibility caused by 'A' pillar, seat position and front windscreen damage and permissible repair. Sub-optimum windscreens (such as those suffering from abrasion or haze effects), tints to windscreens, side screens, rear screens, and shade bands are also areas to be considered.

#### **4.9 Amendments to legislation and enforcement practises**

For those proposals considered to be the most cost beneficial, prepare draft documents to amend the appropriate instruments (e.g. standards, directives, regulations) or develop codes of practice.

#### **4.10 Consultation and Communication with independent experts**

It is expected that various independent experts including those involved in the vision sciences, the repair of vehicle glazing and the development of low cost enforcement tools and safety experts from ROSPA and ETSC will need to be consulted during the course of this work. It is also expected that the work will involve field studies and driving simulators correlated to real world driving conditions.

### **5. OUTPUTS AND MONITORING**

The project should start 1 February 1999 and finish by 31 January 2000.

The following timetable of outputs is indicative only. Tenders should include a timetable based on the work actually proposed:

|                               |  |
|-------------------------------|--|
| Initial task 4.1 report       | Month 3                                  |
| Other task reporting          | Month 6 to 9 as programmed by contractor |
| Draft final report            | Month 10                                 |
| Final report & (presentation) | Month 12                                 |

Quarterly reports will be required in addition to the above.

There will be review points at the end of tasks and the end of each financial year.

#### **5.1 Quarterly reports (2 copies required)**

Quarterly reports must be submitted with each invoice. These reports must:

- Provide a concise summary of progress
- Justify the value of the invoice
- Anticipate the progress and projected spend in the coming quarter; and
- Highlight any potential problems with the project

#### **5.2 Final Report (10 copies required)**

The final report must include the following:

- Executive summary
- Abstract
- Introduction
- Methodology

- Results
- Discussion
- Conclusions
- Recommendations

2 copies of the draft final report and 20 copies of the final report will be required. The contractor should expect to be required to either reproduce or to publish this report but will be permitted to charge for the requested copies.

### **5.3 Presentation of results**

We may ask the contractor to present the project findings to departmental officials and other interested parties.

### **5.4 Electronic reports.**

The principle reports shall also be made available on 3.5" disk, preferably in a Microsoft Word 6.0 format.

## **6. PROJECT MANAGEMENT**

Meetings will take place every quarter to evaluate the research, justify invoices and clarify the direction and content of the future research tasks. Other meetings will be convened as necessary by agreement between the project manager and the customer project officer. Meeting venues will be at the discretion of the customer project officer. The DETR will chair meetings. The contractor will provide the secretariat who will take the minutes and agree them with the customer project officer before distribution.



## 1.0 Vehicle glazing standards

### 1.1 ISO Standard 3537, ECE Regulation No. 43 and Council Directive 92/22/EEC.

#### 1.1.1. Scope

‘ . . . applies to safety glazing and materials for glazing intended to be fitted in the form of a windscreen or other glazing or separating panels on motor vehicles and their trailers . . . ‘

#### 1.1.2. General specification:

‘ . . . safety glazing shall be adequately transparent, cause no noticeable deformation of objects seen through the windscreen, nor cause any confusion between the colours used on road signs. In the event of windscreen breakage the driver must continue to be able to see the road clearly enough in order to be able to brake and bring his vehicle to a halt in complete safety’.

#### 1.1.3. Definitions of glazing types

- toughened glass panel:- a pane of glass consisting of a single sheet of glass having undergone a special treatment intended to increase its mechanical strength and to limit its fragmentation when smashed.
- ordinary laminated glazing:- at least two sheets of glass held together by at least one sheet of plastic material that is sandwiched between them, where none of the sheets has been treated in such a way as to increase its mechanical strength and to limit its fragmentation when smashed.
- treated laminated glazing:- at least two sheets of glass held together by at least one sheet of plastic material that is sandwiched between them, where at least one sheet of glass has undergone a special treatment intended to increase its mechanical strength and to limit its fragmentation when smashed.
- safety glazing coated with plastic:- any of the above glazing with a coat of plastic material on its inner surface.
- plastic-glass safety glazing:- laminated glazing having a single sheet of glass and one or several sheets of plastic laid one on top of the other, at least one of which serves as a sandwich layer. The sheet(s) of plastic is (are) located on the inner surface when the glazing is fitted to the vehicle.
- double glazing:- a unit consisting of two panes assembled at the factory in a permanent manner and separated by a uniform space.
- uniformly toughened glass windscreens:- a glass pane consisting of a single layer of glass which has been subjected to special treatment (*either thermal or chemical*) to increase its mechanical strength and to condition its fragmentation after shattering.

#### 1.1.4. Technical requirements

The ECE Regulation No. 43 and EEC Directive 92/22 provide a description of the apparatus, test conditions and procedure for each of the following mechanical, environmental and optical tests:

##### **Mechanical strength**

- Fragmentation test:- to verify that the fragments and splinters produced by smashing of the pane of glass are such to minimise the risk of injury and in the case of treated laminated glass windscreens to check residual visibility after shattering.
- 227g ball-impact test:- to assess the adhesion of the inter-layer in laminated glass and the mechanical strength of uniformly toughened glass.
- 2260g ball impact test:- to assess the ability of the laminated glass to resist ball penetration.
- Headform test:- to verify the glass pane's compliance with the requirements relating to the limitation of injury in the event of impact of the head against the windscreen, laminated glass and panes of plastic-glass other than windscreens, together with double-glazed units used in the side windows.

##### **Resistance to the environment**

- Abrasion test:- to determine whether the resistance of a safety-glass pane to abrasion exceeds a specified value.
- High-temperature test:- to verify that no bubbles or other defects occur in the inter-layer in a laminated glass or glass-plastics pane when the latter is exposed to high temperatures over an extended period of time.
- Resistance to radiation test:- to determine whether the light transmittance of laminated glass, plastic-glass and plastic-coated glass panes exposed to radiation over an extended period of time is significantly reduced thereby or whether the glazing is significantly discoloured.
- Resistance to humidity test:- to determine whether a laminated-glass, plastic-glass and plastics-coated glass pane will withstand, without significant deterioration, the effects of prolonged exposure to atmospheric humidity.
- Resistance to temperature change test:- to determine whether the plastic material(s) used in safety glazing will withstand, without significant deterioration, the effects of prolonged exposure to extreme temperatures.
- Fire resistance test: to verify that the inner face of a pane of safety glass has sufficiently low burn rate.
- Resistance to chemical agents test:- to determine whether the inner surface of a pane of safety glass will withstand, without significant deterioration, the effects of exposure to the chemical agents likely to be present or used in a vehicle.

##### **Optical qualities**

- Light transmission test: to determine whether the regular transmission of safety-glass panes exceeds a specified value.
- Optical distortion test: to verify that the distortion of objects as seen through the windscreen is not to such an extent as to be likely to confuse the driver.
- Secondary image separation test: to verify that the angular separation of the secondary image from the primary image does not exceed a specified value.
- Colour identification test: to verify that there is no risk of confusion of colours as seen through a windscreen.

**1.1.5. Optical quality testing and abrasion resistance**

**Light transmission testing:**

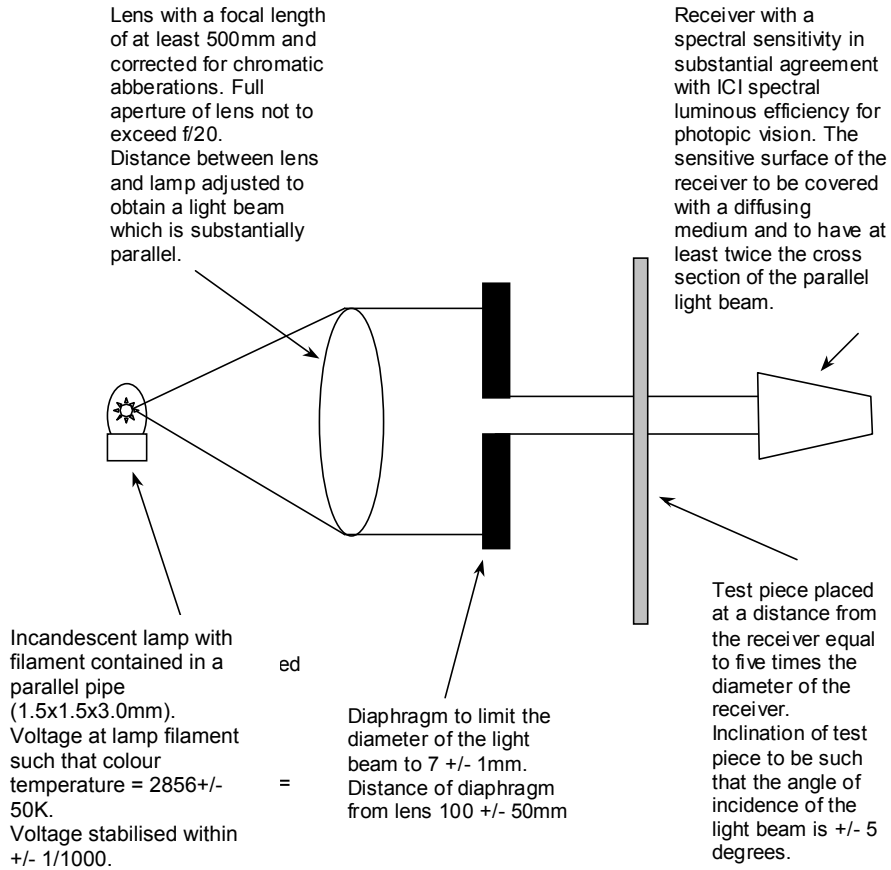

**Figure 1: Light transmission measuring apparatus.**

The regular transmission measured shall not, in the case of windscreens, be less than 75% and in the case of other windows 70%.

For more detailed information refer to Council Directive 92/22/EEC, section 9.1.

**Testing the degree of light scatter due to abrasion or haze**

The process and apparatus for testing resistance to abrasion are outlined below, for exact details refer to Council Directive 92/22/EEC, section 4.0.



The abrasive wheels are each 45-50mm in diameter and 12.5mm thick, consisting of a special finely-screened abrasive embedded in a medium-hard rubber. The wheels have a hardness of 72 +/- 5 IRHD.

The abrasive wheels are mounted in such a way that each wheel rests on the test specimen under a pressure applied by a mass of 500g. The wheels rotate in opposite directions and exert a compressive and abrasive action along curved lines over an annular area of about 30 square cm.

Test piece mounted on a horizontal turntable (deviation from horizontal plane not to be greater than +/- 0.05mm at a distance of 1.6mm from the turntable periphery) revolving counter-clockwise at 65 to 75 rev/min.

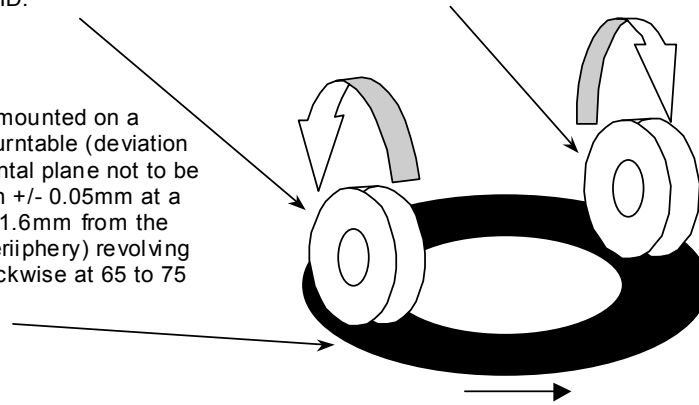

**Figure 2: Abrading instrument**

The apparatus for measuring the before and after abrasion subsequent light scatter and light scatter due to haze are detailed below:

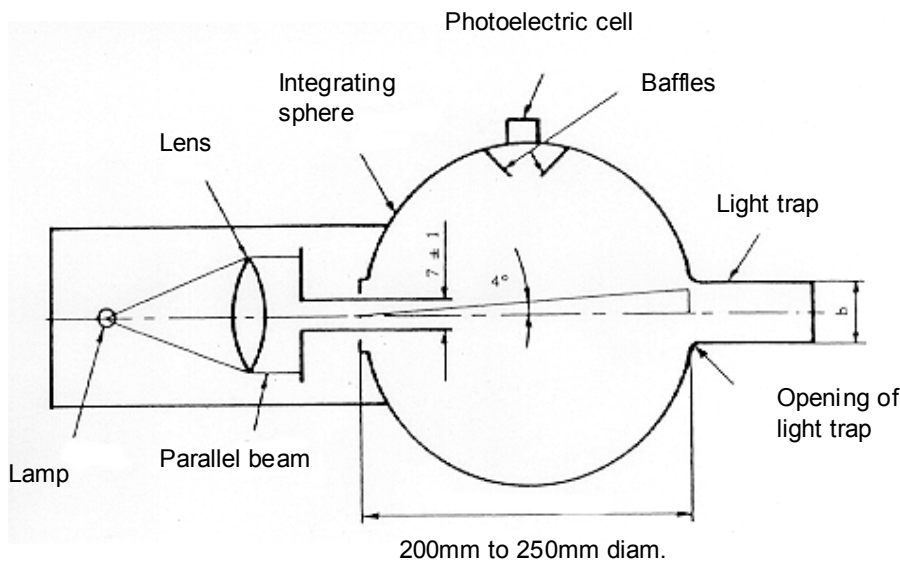

**Figure 3: Hazameter- Light transmission test**

The hazameter measures light scattered as a result of abrasion (or film) on the surface of the test piece. The lamp, voltage, lens and diaphragm are as detailed for the apparatus used in the light transmittance test. The integrating sphere is equipped with entry and exit ports and a photo electric cell mounted in such a way that it cannot be reached by light

coming directly from the entrance port. The exit port is provided with a reflectance standard or a light trap which will absorb all the light when no test piece is inserted in the light beam. The interior surface of the integrating sphere and reflectance standard shall be of substantially equal reflectance.

The test conditions are:

- temperature 20 +/- 5 °C
- pressure 860 to 1060 mbar
- relative humidity 60 +/- 20 %
- test pieces conditioned for a minimum of 48 hours

With the test piece mounted immediately against the entrance port of the integrating sphere, four readings are taken as indicated in the following table:

**Table 1: Hazameter readings**

| Reading | With test piece | With light trap | With reflectance standard | Quality represented                           |
|---------|-----------------|-----------------|---------------------------|---|
| T1      | No              | No              | Yes                       | Incident light                                |
| T2      | Yes             | No              | Yes                       | Total light transmitted by test piece         |
| T3      | No              | Yes             | No                        | Light scattered by instrument                 |
| T4      | Yes             | Yes             | No                        | Light scattered by instrument and test piece. |

Repeat the readings for T1, T2, T3 and T4 at four equally-spaced positions on the test piece.

$$\text{Total transmittance } T_t = \frac{T_2}{T_1}$$

$$\text{Diffuse transmittance } T_d = \frac{T_4 - T_3(T_2/T_1)}{T_1}$$

$$\text{Percentage haze or light scattered } \frac{T_d}{T_t} \times 100\%$$

**Optical distortion test**

- Optical deviation:- the angle between the true and apparent direction of a point viewed through the safety-glass pane, the magnitude of the angle being a function of the angle of incidence of the line of sight, the thickness and inclination of the glass pane and the radius of curvature at the point of incidence.
- Optical distortion:- the algebraic difference in angular deviation  $\Delta\alpha$  measured between two points M and M' on the surface of the safety-glass pane, the distance between the

two points being such that their projections in a plane at right angles to the direction of vision are separated by a given distance  $\Delta x$ .

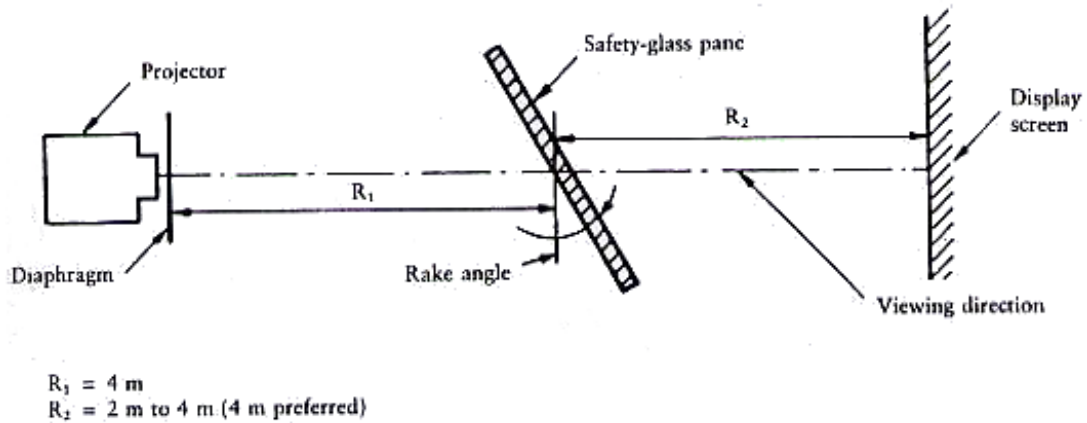
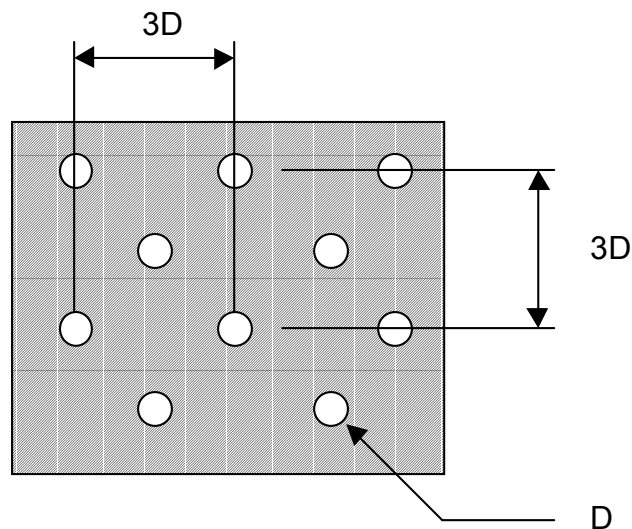

**Figure 4. Arrangement of the apparatus - optical-distortion test.**

The distortion test entails the projection of an appropriate slide (raster) onto a display screen through the safety glass pane being tested. The change caused in the shape of the projected image by the insertion of the safety glass pane in the line of sight provides a measure of the distortion.

In the absence of the safety glass pane to be examined the dimensions of the circular shape shall be such that when they are projected the circles have a diameter of:

$$\frac{R1 + R2}{R1} \Delta x \text{ on the screen, where } \Delta x = 4\text{mm}$$



**Figure 5: Example of raster slide - optical-distortion test**

Where a rapid assessment with a possible margin of error of up to 20% is sufficient, calculate the value of A from the limit value  $\Delta\alpha L$  for the change in deviation and the value of R2, for the distance from the safety glass pane to the display screen:

$$A = 0.145\Delta\alpha L \times R2$$

The relationship between the change in diameter of the projected image  $\Delta d$  and the change in angular deviation  $\Delta\alpha$  is given by:

$$\Delta d = 0.29\Delta\alpha \times R2$$

The type of windscreen shall be considered satisfactory as regards optical distortion if optical distortion does not exceed 2' of an arc in front of the driver i.e. Zone A of the windscreen, and 6' of arc in elsewhere in the swept area i.e. Zone B.

### Secondary-image separation test

Two test methods are recognised:

- target test
- collimator-telescope test

#### Target test

This method involves viewing an illuminated target through the safety glass pane. The target shall preferably be one of the following types:

- an illuminated ring target whose outer diameter,  $D$ , subtends an angle of  $N$  minutes of an arc at a point situated at  $x$  metres. Refer to Figure 6a.
- an illuminated ring and spot target whose dimensions are such that the distance,  $D$ , from a point on the edge of the spot to the nearest point on the inside of the ring subtends an angle of  $n$  minutes of an arc at a point situated at  $x$  metres. Refer to Figure 6b.

Where:

- $n$  is the limit value of secondary-image separation,
- $x$  is the distance from the safety glass pane to the target (not less than 7m)
- $D = x \cdot \tan n$

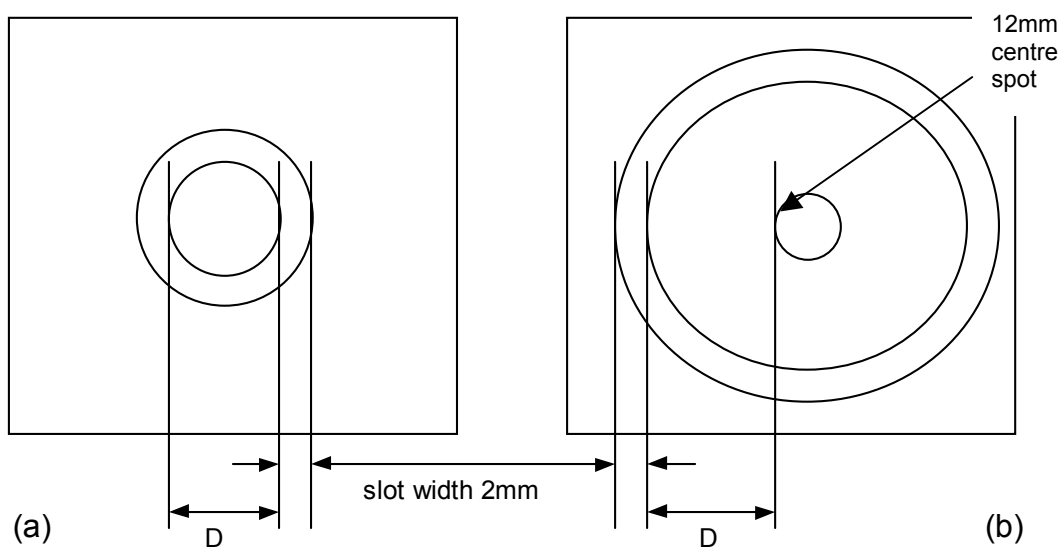
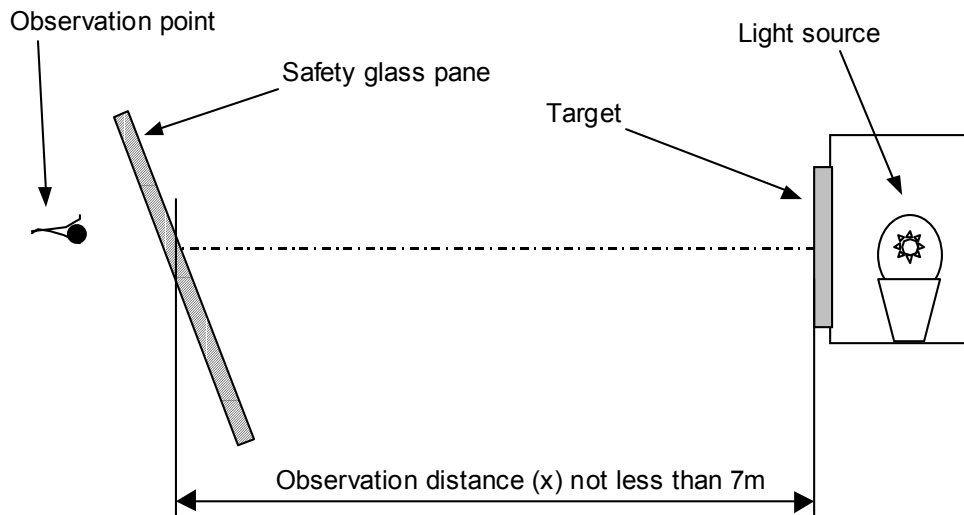

Figure 6: Dimensions of targets - secondary image separation test



**Figure 7: Arrangement of apparatus - secondary image separation test**

When the ring target is used, the primary and secondary images of the circle will separate but should not exceed the limit value  $n$ .

When the ring spot target is used, the secondary image of the spot shifts beyond the point of tangency with the inside edge of the circle but should not exceed the limit value  $n$ .

#### **Identification of colours test**

When a windscreen is tinted four windscreens shall be tested for identifiability of the following colours:

- white
- selective yellow
- red
- green
- blue
- amber.

#### **1.1.6. EEC type-approval markings**

e11

- I made of toughened glass (I/P if it is coated)
- II made of ordinary laminated glass (II/P if it is coated)
- III made of treated laminated glass (III/P if it is coated)
- IV if it is made of plastic glass
- V if this is a pane of glass other than a windscreen
- VI if it is a double glazed unit

## 2.0 Automotive windscreen repair

### 2.1. BS AU 242a:1998 - Code of practice

#### 2.1.2. Scope

‘... gives recommended practices for repairing laminated windscreens damaged by impacts. It applies to HGVs, coaches and passenger cars.

Recommendations include:

- the type and size of damage that can be repaired
- the area on the windscreen in which repairs of particular types can be made
- procedures for the repairer
- steps to assess the quality of finished repairs
- reports and records for completion and retention by the repairer

#### 2.1.3. General specification

The type and size of damage that can be repaired should be limited as a function of the position of the damage on the windscreen. Refer to Table 2 and Figure 8.

**Table 2: Windscreen zones and permitted repairs**

| <b>Zone</b>   | <b>Area</b>   | <b>Permitted repair</b>                 |
|---|---|---|
| A   | Centred on a longitudinal vertical plane passing through the centre of the driver's seat and bounded by the arc described by the driver's wiper | damage within a circle 10mm in diameter |
| B   | area wiped on driver's side, excluding zone A   | damage within a circle 15mm in diameter |
| C   | area wiped on passenger's side, excluding zone B  | damage within a circle 25mm in diameter |
| D   | areas excluding zones A, B and C.   | damage within a circle 40mm in diameter |
| Note 1 - For HGV and coach windscreens, damage up to 150mm in length may be repaired<br>Note 2 - Repairs less than 100mm apart should not be carried out. |   |   |

The MOT test permits repairs to damage in Zone A up to 10mm in diameter and 40mm in all other areas.

Dimensions in millimetres

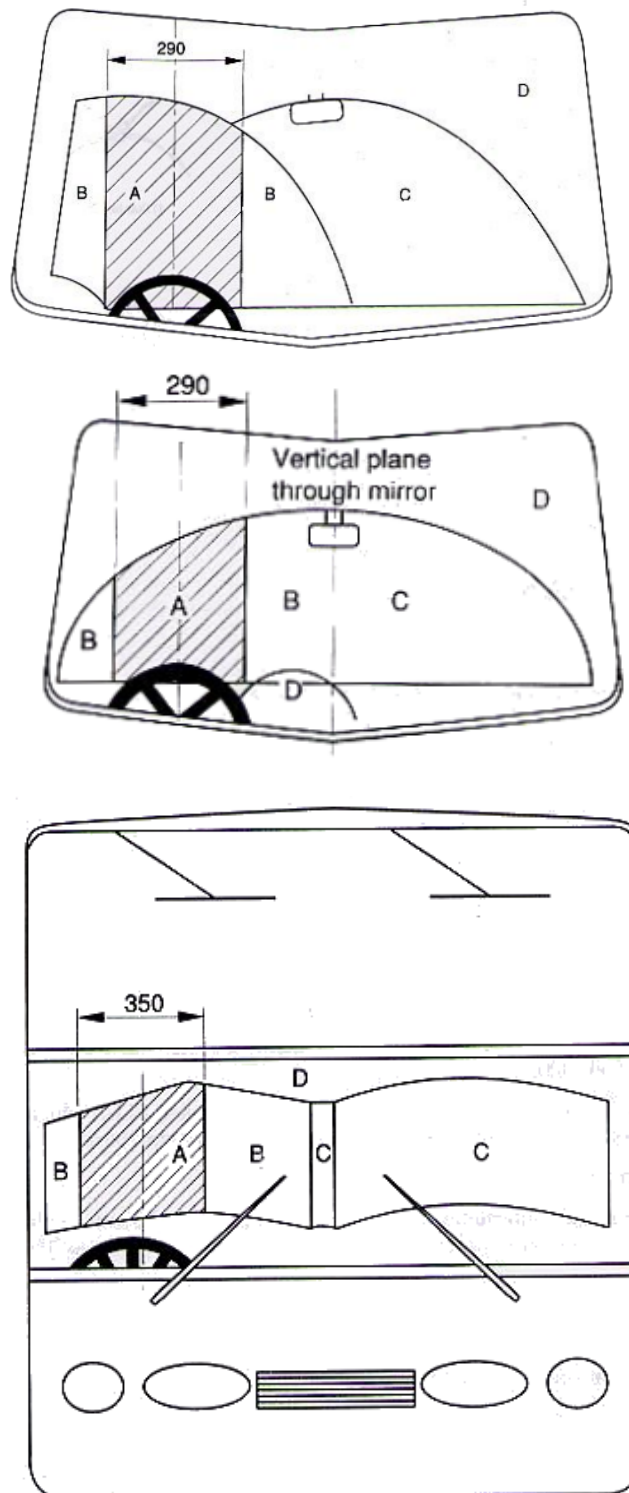

**Figure 8: Windscreen repair zones - a) Passenger car with two wipers, b) passenger car with single wiper, c) HGV/Coach with two wipers (all measurements in mm)**

The following restrictions regarding the type and size of damage should be complied with:

- damage extending through all layers of glass should not be considered repairable in any area of the windscreen
- damage with a crater at the point of impact exceeding 5mm in diameter should not be considered repairable
- if damage, delamination or irreversible contamination (dirt, water) of the inter-layer has occurred, the windscreen should not be considered repairable.

The repairer should inspect the repaired area to ensure it conforms such that: repairs should not show significant optical defects. The damaged area should be clear, but small imperfections may be acceptable;

- visual inspections should be carried out from the inside of the vehicle, under good illumination from a distance of 230mm with normal corrected vision;
- if after repair a residual small dull spot is visible in the damaged area, the spot should not exceed 5mm in diameter;
- repaired areas should be free of voids, air bubbles or foreign materials;
- repaired areas should not interfere with windscreen wiper function.

## **2.2. BS AU 251:1994 – Performance of automotive laminated windscreen repair systems**

### **2.2.1. Scope**

‘ . . . specifies performance requirements for the windscreen repair systems, including the materials used, to be employed for the repair of laminated windscreens that have been damaged by impacts’. It is applicable to the repair of HGV, coach and passenger car windscreens.

### **2.2.2. Definitions**

Windscreen repair material:- a plastics resin material containing as its essential ingredient an organic substance of high molecular weight which is polymerised during the repair procedure to provide adhesive strength and a colourless, weatherproof transparent filler.

#### **Testing**

Each of the resin repair materials supplied with the repair system shall be subjected to the following tests:

- Resistance to humidity
- Resistance to high temperature
- Resistance to radiation
- Visual appearance
- Optical distortion
- Light scatter
- Impact resistance (2260g ball and headform)
- Mechanical strength



### 2.3. M.O.T. Inspection Manual - Windscreens

Repaired windscreens - must be inspected to the same test criteria as original unrepaired windscreens. Repairs must be judged solely on the basis of whether they interfere with vision. An 'invisible' or barely detectable repair, finished flush with the surrounding glass, does not count as damage even if it exceeds the limit on damage allowed in the test.

Scratches - scratches on the windscreen, i.e. light surface scratching, is not to be considered damage. However, an area of concentrated scratching such as caused by the prolonged use of a defective wiper blade which obscures vision is to be considered a reason for rejection if it meets the fail criteria.

#### 2.3.1. Reason for rejection

In Zone 'A' (the swept area of the windscreen in a vertical band 290mm wide, centred on the steering wheel): -

- damage not contained within a 10mm diameter circle
- a windscreen sticker or other obstruction encroaching more than 10mm
- a combination of minor damage areas which seriously restricts the driver's view

In the remainder of the swept area: -

- damage not contained within a 40mm diameter circle
- a windscreen sticker or other obstruction encroaching more than 40mm

Tinting films are not subject to reason for rejection.

Opaque edging on windscreens is not regarded as part of the windscreen.

## 3.0 Motorcycle helmet visors

### 3.1. ECE regulation No. 22 (Incorporating 05 series of amendments) and British Standard BS 4110:1999.

#### 3.1.1. Scope:

'... applies to protective helmets for drivers and passengers of mopeds and of motor cycles with or without side-car and to the visors fitted to such helmets or intended to be added to them.

#### 3.1.2. General specification:

... 'It must be possible to manoeuvre the visor out of the field of vision with a simple movement of one hand. ...

... 'The surface of the visor in the peripheral field of vision of the helmet may include the lower edge of the visor, provided that it is made of a material with at least the same transmittance as the rest of the visor.

Visors shall have a luminous transmittance  $\tau_v \geq 80\%$ , relative to the standard illuminant D65. A luminous transmittance  $80\% > \tau_v \geq 50\%$ , is also permissible if the visor is marked with the symbol shown below and/or with the English words “DAYTIME USE ONLY”. The luminous transmittance shall be measured before the abrasion test.

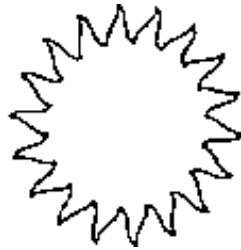

Daytime use only

Visors shall be free from any significant defects likely to impair the vision, such as bubbles, scratches, inclusions, dull spots, holes, mould marks, scratches or other defects originating from the manufacturing process in the field of vision.

Visors shall in addition be sufficiently transparent, shall not cause any noticeable distortion of objects as seen through the visor, shall be resistant to abrasion, resistant to impact and shall not give rise to any confusion between the colour used in road sign and signals. The relative visual attenuation quotient (Q) (*before the abrasion test*) shall not be less than:

- 0.80 for red and yellow signal lights
- 0.60 for green signal light
- 0.40 for blue signal light

### 3.1.3. Definitions

- peak:- an extension to the shell of the helmet above the eyes.
- visor:- a transparent protective screen extending over the eyes and covering all or part of the face.
- goggles:- transparent protectors that enclose the eyes
- ocular areas:- two circles of minimum diameter 52mm spaced symmetrically about the vertical centre line of the visor, the distance between the centres of the circles being 64mm measured in the horizontal front plane of the visor as worn.
- luminous transmittance ( $\tau_v$ )

$$\tau_v = \frac{\int_{380nm}^{780nm} S_{D65\lambda}(\lambda) \cdot V(\lambda) \cdot \tau_F(\lambda) \cdot d\lambda}{\int_{380nm}^{780nm} S_{D65\lambda}(\lambda) \cdot V(\lambda) \cdot d\lambda}$$

- relative visual attenuation quotient (Q)

$$Q = \frac{\tau_{sign}}{\tau_v}$$

where:

$\tau_v$  is the luminous transmittance of the visor relative to the standard illuminant D65.

$\tau_{sign}$  is the luminous transmittance of the visor relative to the spectral power distribution of the traffic signal light.

$\tau_{sign}$  is given by the equation:

$$\tau_{sign} = \frac{\int_{380nm}^{780nm} S_{A\lambda}(\lambda) \cdot V(\lambda) \cdot \tau_F(\lambda) \cdot \tau_S(\lambda) \cdot d\lambda}{\int_{380nm}^{780nm} S_{A\lambda}(\lambda) \cdot V(\lambda) \cdot \tau_S(\lambda) \cdot d\lambda}$$

where:

$S_{A\lambda}(\lambda)$  is the spectral distribution radiation of CIE standard illuminant A (or 3200K light source for blue signal light) See: ISO/CIE 10526, CIE standard colorimetric illuminants.

$S_{D65\lambda}(\lambda)$  is the spectral distribution of radiation of CIE standard illuminant D65. See: ISO/CIE 10526, CIE standard colorimetric illuminants.

$V(\lambda)$  is the spectral visibility function for daylight vision. See: ISO/CIE 10527, CIE standard colorimetric observers.

$\tau_S(\lambda)$  is the spectral transmittance of the traffic signal lens

$\tau_F(\lambda)$  is the spectral transmittance of the visor

### 3.1.4. Optical quality testing and scratch resistance

A test piece (minimum dimension 50mm x 50mm) is taken from the flattest part of the visor (within a defined area) and undergoes ambient-temperature and hygrometry conditioning. Next it is washed, rinsed and dried before undergoing luminous transmittance and light diffusion testing. After testing it is subjected to an abrasion test before undergoing the light diffusion test again.

#### Luminous transmittance testing

In a parallel beam, with the test specimens being irradiated vertically, the spectral transmittance values between 380nm and 780nm are determined. The transmittance and visual attenuation quotient can then be calculated from the given formulae. To calculate the luminous transmittance the spectral distribution of the standard illuminant D65 and the spectral values of the colorimetric 2° standard observer CIE 1931 according to ISO/CIE 10256. The product of the spectral distribution (D65) and spectral values of the standard observer is given in Annex 14 of ECE regulation No. 22.

#### Light diffusion testing

There are three methods given in Annex 11 of ECE Regulation No. 22 to measure the light diffusion of visors both before and after the abrasion test. However, for each method ('a', 'b' and 'c') the light diffusion shall not exceed the following values:

**Table 3: Visor maximum light diffusion values**

| Before abrasion                                | After abrasion                                |
|--|---|
| 0.65 cd/m <sup>2</sup> /l (method 'a' and 'c') | 5.0 cd/m <sup>2</sup> /l (method 'a' and 'c') |
| 2.5 % (method 'b')                             | 20 % (method 'b')                             |

For full details of these tests refer to ECE Regulation No.22 in full.

**Abrasion test**

Three kilograms of 0.5/0.7mm grain size quartz sand is allowed to drop through a gravity tube from a height of 1.65m on to the sample to be tested. The test piece revolves on a turntable, which is mounted at 45° to the gravity tube, at a speed of 250 +/- 10 rpm (Figure 9).

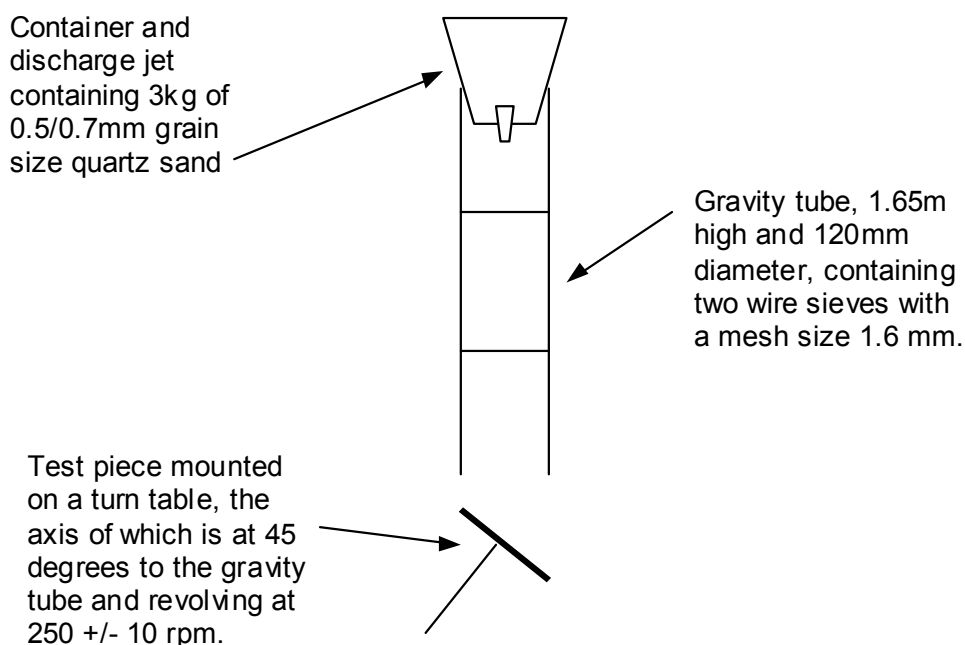
**Figure 9: Sand spray apparatus - abrasion test****Tests of refractive powers - visors**

The apparatus to test for refractive powers is set up as shown below. The target under view is shown in more detail in Figure 10.

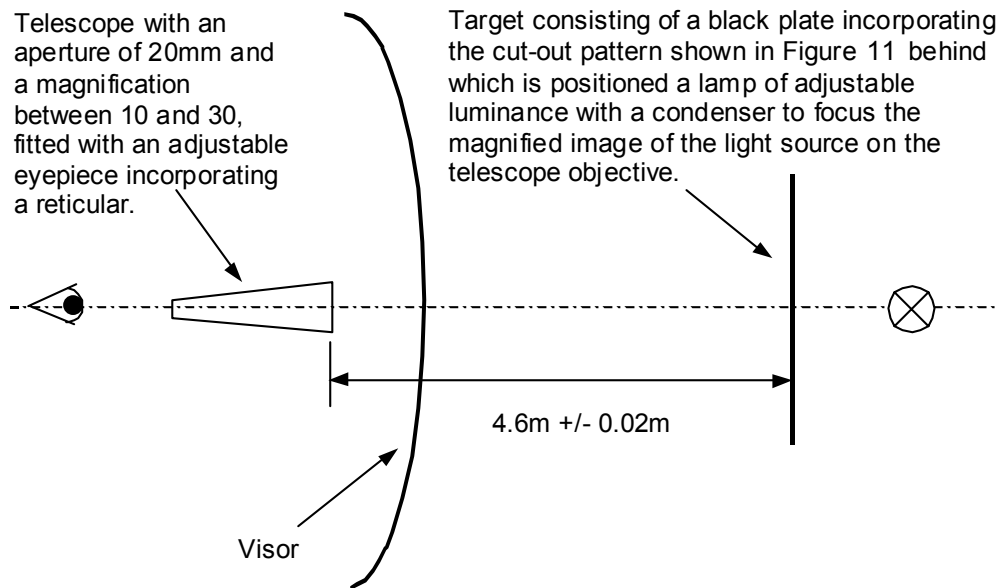

**Figure 10: Apparatus for measuring the spherical and astigmatic refractive powers of a visor**

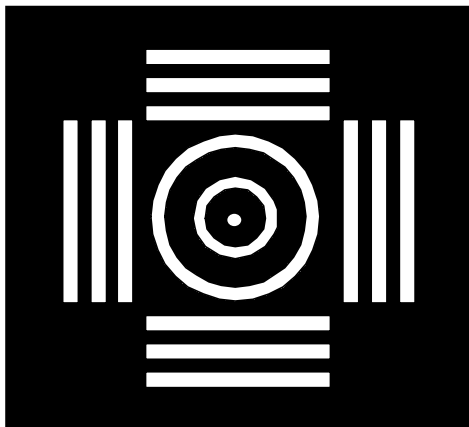

- The large annulus has an outer diameter of 23+/- 0.1mm with an annular aperture of 0.6 +/- 0.1mm.
- The small annulus has an inner diameter of 11.0 +/- 0.1mm with an annular aperture of 0.6 +/- 0.1mm.
- The central aperture has a diameter of 0.6 +/- 0.1mm.
- The bars are nominally 20mm long and 2mm wide with a nominal 2mm separation.

**Figure 11: Telescope target - visor's refractive power test**

The spherical and astigmatic refractive powers of a visor are measured by getting an observer to focus the telescope's reticule and the target and to align the telescope to obtain a clear image. This setting is regarded as the zero point of the focusing scale of the telescope. The focusing adjustment of the telescope is then calibrated with calibration lenses having positive and negative spherical refractive powers of  $0.06 \text{ m}^{-1}$ ,  $0.12 \text{ m}^{-1}$  and  $0.25 \text{ m}^{-1}$  (tolerance +/-  $0.01 \text{ m}^{-1}$ )

The visor is mounted in front of the telescope and :

for visors without astigmatic refractive power the telescope is adjusted until the image of the target is perfectly resolved. The spherical power of the visor is then read from the scale of the telescope.

for visors with astigmatic refractive power the target, on the visor, is rotated in order to align the principle meridians of the visor with the bars on the target. The telescope is focused firstly on one set of bars (measurement D1) and then on the perpendicular bars (measurement D2). The spherical power of the visor is the mean of D1 and D2, while the astigmatic refractive power is the absolute difference of the two measurements.

### **Determination of the difference in prismatic refractive power**

The arrangement of the apparatus to measure this is summarised in Figure 12 below.

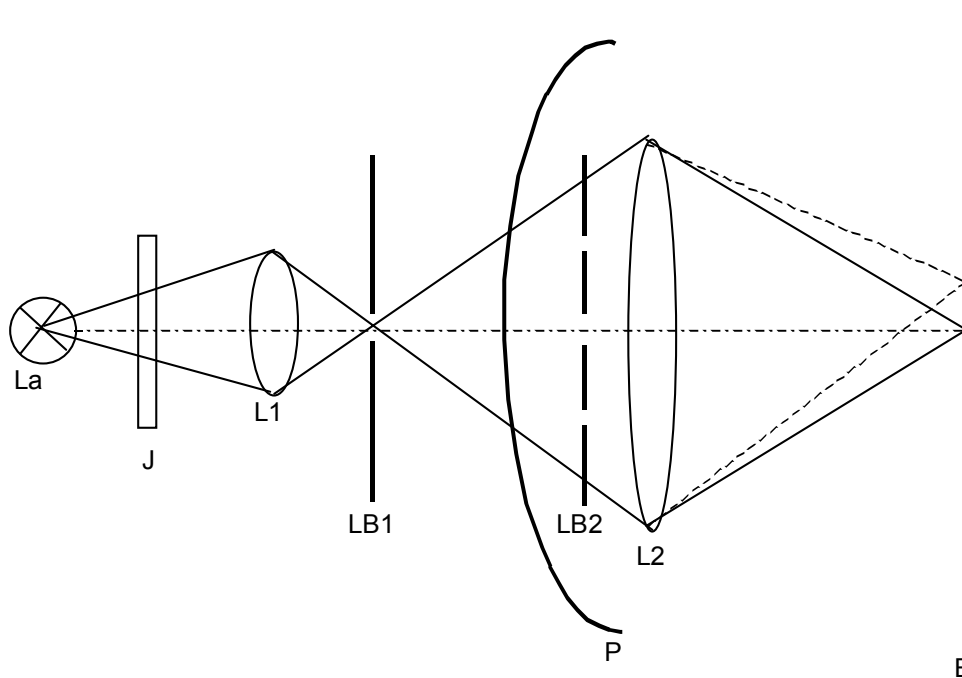

**Figure 12: Apparatus for measuring prismatic difference**

Where:

- La light source e.g. small filament lamp or laser with wavelength of 600+/-70 nm.
- J interface filter, with peak transmittance in the green part of the spectrum (required only if filament lamp is used).
- L1 achromatic lens with focal length between 20 and 50 mm
- LB1 diaphragm with diameter of aperture 1mm nominal.
- P visor
- LB2 diaphragm with apertures 64mm apart (ocular separation)
- L2 achromatic lens, 1000mm nominal focal length and 75mm diameter.
- B image plane

The diaphragm LB1, illuminated by the light source, is adjusted in such a way that it produces an image on the plane B when the visor (P) is not in position. The visor is placed in front of the lens L2 so that the axis of the visor is parallel to the optical axis of the test

assembly. The vertical and horizontal distance between the two displaced images arising from the two ocular areas of the visor are measured. These distance in cm are divided by 2 to give the horizontal and prismatic difference in cm/m.

If the light paths which correspond to the two eye regions cross, the prismatic refractive power is ‘base in’ and if the light paths do not cross, it is ‘base out’.

### **3.2. BS4110: 1999 Specification for Visors for vehicle users**

#### **3.2.1. Scope**

This standard specifies the design and performance requirements for visors for vehicle users and describes appropriate test methods.

It covers visors for attachment to helmets conforming to BS 6658:1995 or replacement visors for attachment to helmets conforming to either BS 2459 or BS 5361 which are now withdrawn.

It does not cover goggles for use by motorcycle or moped riders, which are covered by BS EN 1938.

#### **3.2.2. Terms and definitions**

For the purpose of this British Standard, the definitions given in BS EN 165:1995 and BS EN 1836:1997 and the following apply.

##### **Visor**

Eye protector having a protective transparent screen extending over the eyes and all, or part of the face, attached to a protective helmet in such a way that it can be removed and refitted for cleaning and replacement purposes.

##### **Lens**

That part of an eye protector through which the wearer sees an object. *Note: the term is not used in the optical sense.*

##### **Disposable protective film**

Removable plastic film used to protect the lens prior to use.

##### **Ocular areas**

Two circles of minimum diameter 52mm, spaced symmetrically about the vertical centre line of the eye protector, with a distance of 64mm between the centres of the circles when measured in the horizontal front plane of the visor, as worn.

#### **3.2.3. Optical properties**

The optical properties shall conform to Table 4 and Table 5 below.

**Table 4: Requirements for ocular areas used in visors for vehicle users**

| Refractive powers<br>(permissible tolerances<br>of mounted lens) | Spherical<br>refractive power<br>$D1 + D2/2$<br><br>$m^{-1}$  | Astigmatic<br>refractive power<br>( $D1 - D2$ )<br><br>$m^{-1}$ | Difference in prismatic refractive<br>power<br>cm/m |         |          |
|--|---|---|---|---------|----------|
|  |   |   | Horizontal  |         | Vertical |
|  |   |   | Base out  | Base in |          |
|  | +/- 0.12  | 0.12  | 1.00  | 0.25    | 0.25     |
| Luminous transmittance $\tau_v$                                  | See table 5.  |   |   |         |          |
| Spectral transmittance $\tau_s$                                  | $\geq 0.2 \tau_v$ between 500nm to 650nm. See table 5.  |   |   |         |          |
| Recognition of signal lights                                     | $Q$ red $\geq 0.8$<br>$Q$ yellow $\geq 0.8$<br>$Q$ green $\geq 0.8$<br>$Q$ blue $\geq 0.8$  |   |   |         |          |
| Variation in luminous transmittance                              | Should be measured in accordance with BS EN 167:1995 (7.2).   |   |   |         |          |
| Quality of materials and surfaces                                | Except for a marginal area 5mm wide, the ocular areas shall be free from any significant defects likely to impair vision in use, such as bubbles, scratches, inclusions, dull spots, pitting, mould marks, scouring, grains, pocking, sealing and undulation. The assessment should be carried out in accordance with the method specified in BS EN 167:1995 (clause 5).  |   |   |         |          |
| Resistance to ultra-violet radiation                             | Following exposure of the visor to the ultraviolet radiation in accordance with BS EN 168:1995 (clause 6)*, the diffusion of light, when measured in accordance with BS EN 167:1995 (clause 4), shall not exceed $1cd/m^2/lx$ .<br>* There are a number of differences to the method: <ul style="list-style-type: none"> <li>• new lamps shall be burned in for at least 150h,</li> <li>• an irradiation time of <math>25h \pm 0.1h</math> shall be used,</li> <li>• an ozone free lamp shall be used,</li> <li>• the lamp current shall be stabilised at <math>25A \pm 0.2A</math>.</li> </ul> |   |   |         |          |

**Table 5: Transmittance requirements for ocular areas used in visors for vehicle users**

| Filter category of visor | Ultraviolet spectral range                                |                     |   | Visible spectral range<br>Range of luminous transmittance $\tau_v$<br><br>% |
|--------------------------|---|---------------------|---|---|
|                          | Maximum value of spectral transmittance $\tau_s(\lambda)$ |                     | Maximum value of solar UVA transmittance $\tau_{s,UVA}$ |   |
|                          | 280nm to 315nm  | Over 315nm to 350nm | Over 315nm to 380nm                                     |   |
| 0                        | $0.1 \tau_v$  | Equal to $\tau_v$   | Equal to $\tau_v$                                       | 80.0 to 100.0   |
| 1                        | $0.1 \tau_v$  | Equal to $\tau_v$   | Equal to $\tau_v$                                       | 50.0 to 80.0  |

**3.2.4. Resistance to abrasion**

When tested in accordance with the requirements detailed in Annex C, a light scatter value of not greater than 10% on either surface is required.



## **4.0 Motorcycle goggles**

### **4.1. BS EN 1938:1999**

#### **4.1.1. Scope**

This European Standard specifies requirements and test methods for goggles for motorcycle and moped users (excluding goggles for off-road or competition use).

#### **4.1.2. General specifications - Optical requirements**

Oculars for goggles are attributed to three categories, refer to table 6 in section 3 of the main report. Oculars shall have a luminous transmittance value superior or equal to 18%.

#### **4.1.3. Optical test methods**

The optical test methods for goggles are described in EN167:1995 and are similar to the methods for windscreen and visor optical testing, above.

Tests for spherical, astigmatic and prismatic refractive powers, light diffusion, and transmittance are described.

**Information from TRL fatals database**

| <b>Accident No.</b> | <b>Date</b> | <b>Helmet Type</b> | <b>Visor Colour</b> | <b>Visor Condition</b>      | <b>Light</b> |
|---------------------|-------------|--------------------|---------------------|-----------------------------|--------------|
| <i>nd</i>           | <i>nd</i>   | RF200              | clear               | 4                           | <i>nd</i>    |
| <i>nd</i>           | <i>nd</i>   | Nolan N33          | clear               | 3                           | <i>nd</i>    |
| G164R               | <i>nd</i>   | Shoei X8R          | clear               | 4                           | D            |
| G167R               | <i>nd</i>   | Shoei X8R          | clear               | 4                           | D            |
| G189                | 20/3/95     | Agv                | tinted (du)*        | 4                           | D (1510)     |
| G176                | <i>nd</i>   | Yamaba B12         | clear (no standard) | 4                           | T            |
| G251                | 18/09/94    | Bell               | tinted (du)         | 4                           | D (1240)     |
| G162                | <i>nd</i>   | FM                 | clear               | 4                           | D            |
| G158                | <i>nd</i>   | Driver Italia      | clear               | 2 (partly obscured by tape) | N            |
| G174                | <i>nd</i>   | Arai               | clear               | 5                           | D            |
| G180                | 9/10/93     | Bieffe             | very slight tint*   | 3                           | D (1620)     |
| G179                | <i>nd</i>   | FM                 | clear               | 4                           | T            |
| G187                | <i>nd</i>   | Unknown            | clear               | 3                           | N            |
| G175                | 1/9/93      | FM                 | very slight tint**  | 3                           | N (2045)     |
| G183                | <i>nd</i>   | FM                 | clear               | 4                           | D            |
| G154                | <i>nd</i>   | BMW                | clear               | 3                           | D            |

**Key:**

du = daytime use only

D = daylight

T = twilight

N = Night

*nd* = no data

Visor condition 1= opaque, 3 = scratched 5 = perfect as new

All visors were marked with BS4110 except G176

\* motorcycle hit a car

\*\* motorcycle hit a bus



## Contacts

| Organisation                                  | Notes  |
|---|--|
| Police Force Responses                        | For category 2 visors for daytime use. Would like to see it made a statutory offence under RVLRL to wear during hours of darkness. See letter to BS of 22 Dec 95                                 |
|   | Using Tintman - 200 vehicles tested and on database.   |
|   | Have replaced Fog City interior visor film with Pinlock which has been very good at anti-misting.  |
| AA  | On BS PH/2/5 committee.<br>In favour of category 2 filters   |
| RAC   | On BS PH/2/5 committee.<br>In favour of category 2 filters (see letter to Cathy Bassey, 16 Sept 97)  |
| BMF   | See Appendix 9   |
| ACU   | For category 2 filters. Mainly concerned with racing but also that if BS4110 is not amended road and race riders will still obtain visors that are not certified. See letter to BS 25th Sept 97. |
| RoSPA   | Does not consider category 2 visors would cause problems for a rider with good vision no spectacles or contact lenses. But has concerns that they would be used in unsuitable conditions.        |
| BSI Secretary to PH/2/5                       | Has circulated members with details of project and request for assistance.<br>BS4110 1999 is latest. Changes to abrasion not tints.<br>No tinting work ongoing.                                  |
| BSI Testing                                   | Has just done some work for DETR on abrasion. Demonstrated test equipment for visors.  |
| BSI Chair BS PH/2/5                           | Sunglasses expert, BSI committee member (chair)<br>Confirmed view of committee. Papers available if required   |
| Chair BS PH/2 & member PH/2/5                 | Provided information on Sunglasses standards<br>Misting test is comparative  |
| CEN Chair TC85 WG1 – sunglasses TC WG5 Visors | Developed drop grit test – has sent details of the background to this new form of abrasion test.   |

| Glazing industry  |   |
|---|---|
| Pilkington special glass Ltd<br>Member of BSI committee PH/2 – eye protection | Pilkington special glass manufacture sunglasses for use when driving and may be interested in participating in the study. Re: traffic light signal recognition etc, set out in European sunglasses standard BS EN 1836. |

| <b>Vehicle glazing repairers/tinters</b> |   |
|--|---|
| Pentagon Auto-tint                       | Demonstrated car window tinting and provided information on materials, reasons for tinting and research on tinting effects.   |
| Auto Glass                               | Will demonstrate repairs etc.<br>Liases with AA, RAC, Halfords and Pilkington on quality control.                             |
| Save-a screen                            | Self employed one-man business based local to Loughborough.<br>Can supply used windscreens for tests and demonstrate repairs. |

| <b>Motorcycle helmet, visor and goggle manufacturers</b>    |  |
|---|--|
| Motor Cycle Industry Association Ltd & BSI PH/2/5 committee | In favour of Category 2. Make it illegal to wear a visor less than 80% in dark or poor light. Mark the visors to help enforcement. See letter to committee of 7 Aug 1997 |
| Bob Heath Visors  | Meeting held. Views as per others on BS committee for visors   |

| <b>Researchers</b>  |   |
|---|---|
| UMIST   | Wrote review report on vision and driving. Contacted for opinions and current relevant work and contacts.   |
| TRL   | Consulted regarding previous visor vision test  |
| Aston University<br>Director of Clinical Studies<br>PhD MCOptom | Contacted for opinions and current relevant work and contacts.  |
| Health and Safety Laboratories<br>Sheffield                     | Has been co-ordinating a EC-funded research project on assessing resistance of eye protectors to fogging by condensed moisture, which may be relevant. So far the work has only considered goggles and spectacles, but some of the principles and techniques may be common to visors. |

## Driver vision survey data

Interview sample

Total sample size = 30 , (14 male, 16 female)

### Age and years of driving

|         | Age | Years driving |
|---------|-----|---------------|
| Average | 42  | 23            |
| Minimum | 21  | 4             |
| Maximum | 72  | 54            |

### Age of vehicle

| (Years) | Age of car | How long owned |
|---------|------------|----------------|
| Average | 7.3        | 2.9            |
| Minimum | 2          | 0.1            |
| Maximum | 15         | 13             |

Have you ever had a new windscreen fitted?

| No | Yes |
|----|-----|
| 27 | 3   |

Does mist on the inside of your windscreen ever reduce your vision outside the car?

|           |    |
|-----------|----|
| never     | 8  |
| rarely    | 1  |
| sometimes | 18 |
| often     | 3  |

**If Yes: under what circumstances?**

- Cold weather
- Cold weather
- At night
- In winter - cold weather outside and people breathing condensation
- Raining & cold
- winter
- Cold days, evenings worse
- very cold and have heaters on
- Cold weather
- Clears very quickly
- Winter od Summer rain
- Early morning
- Early morning
- Winter mornings
- Cold outside, damp people inside
- Rain
- cold early mornings
- Cold, rain
- back windscreen & front when raining
- cold
- Muggy or damp weather
- Winter, cold
- Rain, cold and damp people in car

**How do you clear it?**

|             |    |
|-------------|----|
| Fan         | 20 |
| cloth       | 1  |
| hand        | 0  |
| other       | 1  |
| no response | 8  |

**Do you ever have to clear it while driving?**

|             |   |
|-------------|---|
| never       | 8 |
| rarely      | 6 |
| sometimes   | 6 |
| often       | 1 |
| no response | 8 |

**When did you last clean the inside of your windscreen of accumulated dirt?**

|                          |    |
|--------------------------|----|
| Within the last week     | 7  |
| Within the last month    | 13 |
| Within the last 3 months | 4  |
| Longer                   | 2  |
| No response              | 4  |

**Comments**

- Only did it once - keep fan on until clear and keep on to keep clear
- If fan on then clears throughout drive (until clear)
- When mists up
- If very cold with lots of people in the car
- Wait until gone
- Won't drive if can't see
- Leave fan/heater on until clear
- Rain
- use hand or leave fan on
- only initially when set off

**Do you clean the inside of your windows routinely or just when you notice they are dirty.**

|             |    |
|-------------|----|
| Routinely   | 8  |
| when dirty  | 21 |
| no response | 1  |

**Have you ever experienced problems with vision because of accumulated dirt on the inside of your windows (e.g. due to dazzle from headlights at night)?**

|           |    |
|-----------|----|
| never     | 20 |
| rarely    | 3  |
| sometimes | 7  |
| often     | 0  |



**Comments e.g. vision problems experienced**

- blobs in line of sight
- Glare from sun
- Dazzle, blobs in line of vision
- Momentarily - wipe away as drive
- Keep cloth in car
- Smears can scatter glare and make it worse
- Night-time, oncoming cars - dazzle rain, lessened vision
- reduced visibility, especially in daylight, low sun

**Do you ever experience problems driving in bright sunlight?**

|             |    |
|-------------|----|
| never       | 8  |
| rarely      | 1  |
| sometimes   | 16 |
| often       | 4  |
| no response | 1  |

**Comments e.g. vision problems experienced**

- My eyes are very susceptible to bright lights so I wear prescribed distance sunglasses
- impossible to see due to glare off road - one occasion
- Temporary blinded, slow down
- Dazzle, reflected dazzle from other car windows, squint if very bright
- If in your eyes
- Glare - real problem. Winter sunshine very bad
- Glare
- glare
- Glare, not able to see
- Adjust eyes
- Glare
- Would if not wear sunglasses
- Always wear sunglasses
- Too bright
- dazzle from low sun and reflected sun
- Glare - reflection of dashboard onto windscreen
- wear cap
- Can't see, glare
- Dazzle
- glare
- low sun cases glare & dazzle

**If yes what do you do about it?**

- Wear sunglasses & use visor
- see previous
- visor down, drove slowly
- Put visor down
- Use visor flap, squint if necessary
- Put visor down, wear sunglasses
- Put sunglasses on (paler in middle) - make sure glass demisted before set off - anticipatory action
- Sunglasses
- Put visor down to prevent it
- Always drive with visor down
- Put visor down
- Wear sunglasses, pull visor down
- Sunglasses
- Sunglasses
- wear sunglasses and pull down visor
- Visor down, squint, slow down
- Squint
- visor down, put on sunglasses
- Visor down
- visor down
- put visor down and sunglasses on
- put visor down, other visor on passenger side as well if it helps. Slow down and concentrate on road immediately in front.

**Have you had any accidents or near misses because of glare or dazzle from bright sunlight?**

|             |    |
|-------------|----|
| No          | 21 |
| Yes         | 1  |
| No response | 8  |

**Description**

- Winter low sun (previous car), especially if windscreen frosty - can't see parked cars as back out of drive

**Are any of the windows in your car tinted?**

|             |    |
|-------------|----|
| Yes         | 8  |
| No          | 19 |
| No response | 3  |

- All windows tinted grey
- rear and side rear windows grey
- All of them, green on top windscreen. All a bit grey
- Slight tint, grey
- Slight tint, grey
- Windscreen tinted at top - green others just slightly grey
- Top of windscreen is blue
- all greyish

**If yes, were they tinted when you acquired the car?**

|     |   |
|-----|---|
| Yes | 8 |
| No  | 0 |

**Did it influence your purchase decision?**

|     |   |
|-----|---|
| Yes | 1 |
| No  | 7 |

-

Like tinted windows as give privacy and reduce glare

**Ignoring the cost, would you consider having tinted windows in your car?**

|             |    |
|-------------|----|
| Yes         | 13 |
| No          | 7  |
| No response | 10 |

**Which?**

- front
- At top of windscreen
- Never seen any to compare with
- Windscreen
- Windscreen, all of them
- have tinted windows in other car, paid to put them in. Don't use this car for long journeys
- Windscreen and front sides
- Side & back possible mild tint on front to help glare
- All of them
- Look tacky
- Windscreen and side windows
- All
- just a fashion thing to have tinted. Like to keep colours and brightness as they are, esopic times of day want as much light as possible (as at night)
- Windscreen
- Windscreen
- all of them
- windscreen

**Why?**

- To help stop glare
- Only at top, not get in way of vision - would be a problem if tinted at sides of windscreen
- If it would cut down glare, not matter for rest
- would do back ones if had children
- Reduce glare
- Car too old
- Like tinted windows. But might reduce visibility if front ones done
- Save wearing sunglasses
- Reduce glare into driver and front and back passengers
- had before & liked them
- to reduce glare
- reduce glare
- have had tinted windows in previous car and liked them

**Thinking now about the pillars at the side of the windscreen in your car (A pillars).  
Would you say that they ever restrict your vision out of the car?**

|             |    |
|-------------|----|
| never       | 13 |
| rarely      | 5  |
| sometimes   | 7  |
| often       | 4  |
| no response | 1  |

- Turning 90degrees onto other road
- Roundabouts
- Punto always restricted vision - Ford Escort roundabouts cause problems
- Tight T junctions, when leaning forward to see
- Turning right at T junctions, leaning forward, small angle to see left between tak stickers, pillar and rear-view mirror
- Quite narrow
- Turning onto major road
- Are very thin on this car
- Turning right
- back ones more a problem
- 90degree turns, pulling out onto dual carriageways off slip roads
- Two cars approaching junction - one obscured and roundabouts
- Looking right for 90 degree junction
- reversing into spaces - difficult judge where sides are
- Roundabouts or corners
- twisty bends

**Are you aware of ever having to move your head to be able to see around the pillar?**

|             |    |
|-------------|----|
| never       | 11 |
| rarely      | 4  |
| sometimes   | 10 |
| often       | 4  |
| no response | 1  |

- Roundabouts & reversing
- When peering round 90degree turns
- Roundabouts
- sit back and look through side window instead
- A little bit, when turning
- will do at some point
- Might do but unaware
- as previous plus when parking
- have learnt to do it . Saab was worst car for it
- parking
- twisty bends
- sign posts when stationery

**How does this pillar compare to other cars you have driven in terms of its effects on visibility?**

|             |    |
|-------------|----|
| same        | 10 |
| better      | 8  |
| worse       | 5  |
| no response | 7  |

**Comments**

- Better than older Polo
- Worse than mini, better than punto
- Similar
- Later versions of same car were improved. Other Volvos also better
- Narrower than newer cars driven
- Better than older cars
- Never really noticed
- better than Ford Mondeo
- Worse than small cars - Nova
- No difference
- better than Saab
- better than Nissan Micra
- Never really been a problem
- Mazda about average. Saab was worse
- Worse than Toyota starlet
- is wider than escort
- same as other Rovers, better than some others
- only ever had Renault

**Have you had any accidents or near misses because of things being obscured by this pillar?**

|             |    |
|-------------|----|
| Yes         | 2  |
| No          | 27 |
| No response | 1  |

**Description**

- Approaching T junction 3 or 4 near misses over the years (various cars)
- Near miss, roundabouts, didn't see car



## Motorcyclists eye protection survey data

### Interview sample

Public = 28, 25 male, 3 female  
 Professional = 14 male, 0 female

### Age and years of riding

|         | General public |              | Professional |              |
|---------|----------------|--------------|--------------|--------------|
|         | Age            | Years riding | Age          | Years riding |
| Average | 41             | 15           | 39           | 20           |
| Minimum | 22             | 1            | 32           | 15           |
| Maximum | 73             | 44           | 5            | 25           |

### Size of motorcycles ridden

|              | General public | Professional |
|--------------|----------------|--------------|
| Upto 250cc   | 3              | 0            |
| 260 – 500cc  | 7              | 0            |
| 510 – 1000cc | 16             | 1            |
| Over 1000cc  | 2              | 13           |

### Use of motorcycle (multiple responses allowed)

|              | General public | Professional |
|--------------|----------------|--------------|
| Commuting    | 21             | 7            |
| Professional | 6              | 13           |
| Leisure      | 34             | 14           |

### Frequency of riding

|         | General public | Professional |
|---------|----------------|--------------|
| Daily   | 13             | 13           |
| Weekly  | 11             | 0            |
| Monthly | 4              | 1            |

### Motorcycle club membership

|                                     | General public | Professional |
|-------------------------------------|----------------|--------------|
| None                                | 21             | 5            |
| BMF                                 | 1              | 2            |
| Institute of Advanced Motorcyclists | 1              | 6            |
| Blue Knight Motorcycle Club         | 0              | 2            |
| Kent Advanced Motorcycle Group      | 2              | 0            |
| Kawasaki Riders Club                | 2              | 0            |
| Ducati Club                         | 1              | 0            |



**Motorcycle magazines and newspapers read**

|                        | <b>General public</b> | <b>Professional</b> |
|------------------------|-----------------------|---------------------|
| None                   | 5                     | 1                   |
| Motor Cycle News       | 12                    | 8                   |
| Ride                   | 3                     | 3                   |
| Bike                   | 6                     | 7                   |
| Performance Bike       | 7                     | 1                   |
| Superbikes             | 3                     | 1                   |
| Motorcycle Sport       | 0                     | 1                   |
| Classic Bike           | 2                     | 0                   |
| The Classic Motorcycle | 2                     | 0                   |
| Streetfighter          | 2                     | 0                   |
| Other                  | 2                     | 0                   |

**Type of helmet and eye protection worn**

|                | <b>General public</b> | <b>Professional</b> |
|----------------|-----------------------|---------------------|
| Helmet         |                       |                     |
| Full face      | 28                    | 14                  |
| Open face      | 0                     | 0                   |
| Other          | 0                     | 0                   |
| Eye protection |                       |                     |
| Visor          | 28                    | 14                  |
| Goggles        | 0                     | 0                   |
| other          | 0                     | 0                   |

**Age of current eye protection**

|         | <b>General public</b> | <b>Professional</b> |
|---------|-----------------------|---------------------|
| Months  |                       |                     |
| Average | 20                    | 21                  |
| Newest  | 1                     | 1                   |
| Oldest  | 96                    | 60                  |

**How often would you say you ride under the following conditions?**

|                 | <b>Professional</b> |        |           |       |             |
|-----------------|---------------------|--------|-----------|-------|-------------|
|                 | Never               | Rarely | Sometimes | Often | No response |
| Rain            | 0                   | 0      | 1         | 13    | 0           |
| Darkness        | 0                   | 0      | 1         | 13    | 0           |
| Bright sunlight | 0                   | 0      | 2         | 12    | 0           |
| Fog/mist        | 0                   | 1      | 7         | 6     | 0           |
| Snow            | 1                   | 7      | 3         | 1     | 2           |

**Comments e.g. vision problems**

- Misting!
- rain blurs vision on visor at low speeds and can get through vents onto inside of the visor where it cant be wiped clear
- rain - vision obscured droplets/misting Fog - misting/condensation
- Bright sunlight causes problems, due to having no sun visor to pull down. Sunglasses are uncomfortable and may affect BS Standards in impact? rain droplets/mist on o/s of visor can be a problem especially at night.
- Problems in bright sunlight with clear visor - glare from sun, so sunglasses worn under visor
- In rain visors fog up, Bright sunlight you require proper sunglasses, snow conditions dazzle at times
- Difficult in rain in slow riding conditions - at speed wind throws rain droplets off
- Visor misting tried fog city made a small improvement
- steaming up
- misting

|                 | General public |        |           |       |             |
|-----------------|----------------|--------|-----------|-------|-------------|
|                 | Never          | Rarely | Sometimes | Often | No response |
| Rain            | 3              | 9      | 8         | 8     | 0           |
| Darkness        | 2              | 8      | 11        | 7     | 0           |
| Bright sunlight | 0              | 1      | 6         | 21    | 0           |
| Fog/mist        | 8              | 6      | 8         | 6     | 0           |
| Snow            | 17             | 6      | 0         | 4     | 1           |

**Comments e.g. vision problems**

- None other than traditionally associated with motor cycles
- Limited vision at night
- before tinted visors, low sun caused problems
- Chose tinted visor to avoid glare from sunlight
- Simpson visor v dark
- Misting up is a problem, under fog/mist and sometimes under rain. Dead flies are a problem sometimes and long journeys in the summer.
- clear visor will replete in sun and steam in rain
- rain - visor steams up and lift visor so you get rain in your face and still cant see. Rain & dark, droplets and you get 10000 sets of headlights coming towards you
- glasses often uncomfortable with helmet and when raining need windscreen wipers when sunny need to change to sunglasses

**Do you even have problems seeing through your visor or goggles due to misting up/fogging?**

|             | General public | Professional |
|-------------|----------------|--------------|
| Often       | 5              | 4            |
| Sometimes   | 11             | 9            |
| Rarely      | 3              | 1            |
| Never       | 8              | 0            |
| No response | 1              | 0            |

**Comments e.g. circumstances, vision problems****Professionals**

- Cold days - Wet conditions water running down inside of visor
- Usually conditions or rain when the rider is relatively warm. It is necessary to then with the visor up to see the road ahead or to attempt to clear the fogging the eyes are then unprotected
- Fog/Mist/rain constant wiping of outside surface with glove - distancing from attention on road
- Visor always mists during cold and wet weather when fully closed
- Visors of mist up in rain/fog and on cool damp mornings. Help up at junctions/ lights/traffic. Not normally too bad whilst on move. I usually keep visor slightly open for ventilation.
- Early morning(using helmet when coming out of the warm home into cold air) heavy rain falls, winter riding
- Heavy rain
- I use a foggcity - Very Good
- I use a foggcity
- When damp or early morning
- Bad weather conditions
- rain

**General public**

- Use washing up liquid
- when riding in town
- cold autumn nights
- winter evenings
- In winter waiting at traffic lights, junctions etc.
- anti-fog helmet
- rain
- cold and hot weather - condensation and perspiration
- rain, fog and night
- In traffic, put visor up to help see, then when put it down it's wet inside
- Insert to prevent air form nose & mouth reaching visor - anti-fog mask
- cold
- wet weather
- rain or cold
- especially if raining hard
- If visor doesn't mist, glasses often do

**Have you/do you ever experience problems due to scratches on your visor/goggles?**

|           | <b>General public</b> | <b>Professional</b> |
|-----------|-----------------------|---------------------|
| Often     | 2                     | 0                   |
| Sometimes | 7                     | 1                   |
| Rarely    | 3                     | 7                   |
| Never     | 16                    | 6                   |

**Comments e.g. circumstances, vision problems****Professionals**

- With heavy use during police patrol work the visor last at least two years. However the visor is usually cleaned before the start of each shift and the helmet placed in a protective bag between shifts
- Latest "ZA" visors rarely scratch and if they do, do not unduly obscure vision or cause "starring" as old technology visors
- mainly sunlight glare
- never had problems because visor changed on regular basis
- I change the visor when scratched
- I change it as soon as it is scratched
- Always change visor if it gets scratched and always clean daily
- Stone chips and cleaning scratches
- replaced if affected
- 

**General public**

- gradual build up of scratches until a new visor is required.
- in bright sun light
- don't let it get scratched
- throw away if get any on
- people knock it and scratch it
- replace them if get scratched
- cheap visor will scratch
- change if gets scratched
- what wears them out
- throw away if gets scratched
- look after it
- sunshine causes problems

**Do you ever experience problems of glare from bright sunlight while riding?**

|           | <b>General public</b> | <b>Professional</b> |
|-----------|-----------------------|---------------------|
| Often     | 5                     | 5                   |
| Sometimes | 14                    | 6                   |
| Rarely    | 0                     | 1                   |
| Never     | 9                     | 2                   |

**Comments e.g. circumstances, vision problems****Professionals**

- Low sun & reflected glare
- Low sun conditions or wet road surfaces in bright sunny conditions
- Unable to see without squinting causing eye strain
- Particular problem when riding into sun, especially when low in sky or over wet roads
- Wear sunglasses
- Riding over browse hills into sunlight vision problem blindness for a few seconds. Early morning sun rises, you don't know when it's going to get you in the eyes. Bright sunlight reflecting off wet roads (evil)
- The visor is clear, you need a tinted visor
- I have to use sunglasses to stop this
- Use sunglasses
- 

**General public**

- Low sun
- when sun is low
- Tinted visor
- with dark visors
- Low sunlight
- Sunglasses help a peak would be useful sometimes but is a problem at higher speeds
- as above
- glare
- every day
- Glare a real problem, even with smoked visor
- and headlights are major problem
- wear tinted visor when need to
- will reflect sun, very difficult to see
- sun of wet roads
- dazzle
- dark in sun and clear when not
- but I generally wear sunglasses anyway, whether on bike or in car
- If can't glasses, reflective glare off wet roads in bright sunlight is evil
- 

**Do you find times when visors/goggles which reduce glare would be useful?**

|            | <b>General public</b> | <b>Professional</b> |
|------------|-----------------------|---------------------|
| Yes        | 24                    | 11                  |
| No         | 0                     | 2                   |
| Don't know | 4                     | 1                   |

**Comments – why and when?****Professional**

- When the sun is low
- Sunrise and sunset especially during winter low sun positions
- Bright sunlight generally - low sun e.g. late evening
- Always wear sunglasses
- Dark visors are particularly good at reducing glare in bright sunlight conditions. Even when slightly overcast - relieve eye strain /Headaches during daylight only though
- Obviously in bright sunlight and glare caused by sun, lights, glare from wet roads. Reduces eyestrain.
- Riding in wet sunny conditions also snow conditions
- Bright sun brings on hay fever and sneezing
- It would be nice if you could have a reactor type visor like you can by glasses lens
- low winter sun

**General public**

- Most of time
- Bright sunlight
- Bright sunlight
- As for bright sunlight - sunglasses too limited & complicated
- for sunlight
- in the evening , against sunlight
- bright sunlight, car headlights & built up areas
- Bright sunlight , headlights at night
- use sunglasses
- bright sunlight
- every day
- sun, all the time
- full headlights main problem
- bright sunlight
- smoked/tinted are very good to reduce glare . All the time good, but night no good
- sunlight
- Sunlight
- bright lights of cars affect vision
- problems if use in dark - change colour visor would be a possibility
- wear tinted when sunny
- bright sunlight
- at times when sun straight in eyes. Wearing sunglasses is difficult
- when wet but bright

**Is/are your visor/goggles tinted?**

|     | <b>General public</b> | <b>Professional</b> |
|-----|-----------------------|---------------------|
| Yes | 12                    | 1                   |
| No  | 16                    | 13                  |

- Blue Iridescent
- dark
- gold
- Gold#1 ¼ tint
- medium
- race v dark
- V dark
- Blue mirror finish
- illegal black
- legally smoked
- black for racing

### Have you ever used tinted visors or goggles?

|     | General public | Professional |
|-----|----------------|--------------|
| Yes | 16             | 8            |
| No  | 12             | 6            |

### Amount and colour

- dark (medium)
- blue mirror finish
- all black
- light smoked glare
- Black or graduated
- Graded
- Blue externally/black inside
- Slight tint black
- light tint black
- Black tint
- light tint black

### Why?

- comfort & style
- during bright day
- looks better than clear
- reduce glare
- on my old helmet
- long time ago
- To reduce glare
- During motorcycle racing events
- Avoid glare
- reduce glare effectively - more comfortable than wearing sunglasses
- Just to try but preferred sunglasses

- To stop sun glare
- Cut glare
- to reduce glare

#### **What were the benefits of the tinted visor/goggles?**

- Reduced glare & reduced eye squint
- Reducing glare and dazzle to an acceptable level without the need to wear sunglasses under the helmet. Being a person who wears spectacles the only other option is to wear clip-on sunglasses which are heavy or prescription sunglasses which are expensive
- Aid Vision
- Particularly good at reducing glare - eye strain/headaches. Much more comfortable than wearing specs under helmet which dig into bridge of nose above ears - might cause injury in RTA
- Gave good all round tinted vision and not as cumbersome as sunglasses
- Stop glare from bright sunlight (safer to ride)
- Cuts glare helps to stop sneezing due to hay-fever helps prevent migraine through bright light
- did not trust the tinted visor for U/V eye protection
- Loss eye strain
- sun & looks good
- Looks good, can see in bright light
- Comfort with vision
- convenience & vision in sunlight
- reduced glare
- better vision & cosmetic
- reduced glare
- reduce glare
- reduce glare
- reduced glare
- reduce glare
- very good in sun as I ride most in sun. rubbish at night. Look good
- Reduces glare without need for glasses
- See where going, don't have sun visor & not able put sunglasses on like drivers can
- no benefits

#### **Were there any disadvantages to using tinted visor/goggles?**

- Night time visibility impaired
- Tints do not allow for changes in light levels or failing light conditions ie. on a bright sunny day entering an area with overhanging trees, entering a tunnel etc. could cause problems
- Had to carry spare clear visor if trading at night in same journey
- Unsuitable for riding on unlit roads at night
- Can't remove visor if it goes dark, because of reduce light
- Poor visibility at night (not safe)
- Night time use been out in the rain
- dark days
- not really



- can't see at night
- When it gets dark cant see
- limited visibility at dusk
- caught out at night/overcast
- You cant see at night
- Night time if get caught without clear visor then have to come back without one on
- not always smoked enough - still have problems with glare even with tinted visor
- if gets dark or cloudy get reduced vision
- night times could not use
- shouldn't wear at night
- night riding problems

**Have you ever ridden with tinted visor/goggles at night or during poor visibility?**

|     | <b>General public</b> | <b>Professional</b> |
|-----|-----------------------|---------------------|
| Yes | 14                    | 6                   |
| No  | 14                    | 8                   |

**Comments**

- Tinted visors at night severely affected contrast. Kerbs and road edges merge and are difficult to pick out
- With a graduated tint visor which had a yellowish tint. The yellow tint enhanced vision in low light conditions as per night driving glasses
- Left home in bright sunlight and got caught in heavy rain/spray - no real affect on vision. Returned home after dark with dark visor - which partially reduced vision on unlit road - No problems on roads with street lighting
- Used yellow glasses/goggles at night to reduce glare - better visibility
- I change visor
- you can not see a thing in the dark
- reduce vision
- just riding. No problems
- On way home at night or if gets overcast. No real probs - go slower
- visibility vastly reduced
- adjust riding to suit visibility
- Couldn't see at all
- as previous
- no problems
- never worn tinted visor
- not very good
- lots of times fog, snow, night and rain
- wouldn't want to
- couldn't see well - not choose to do it
- couldn't see well
- Is hard, swap for clear
- Long time ago
- Are you legally allowed to ride at night with tinted visor

**Would you be prepared to use tinted visor/goggles in bright daylight and change to clear at times of poor visibility and night-time?**

|     | General public | Professional |
|-----|----------------|--------------|
| Yes | 18             | 11           |
| No  | 10             | 3            |

**Thinking about removing and re-fitting your visor to your helmet, would you rate this task as...**

|                | General public | Professional |
|----------------|----------------|--------------|
| not done       | 4              | 0            |
| very easy      | 11             | 9            |
| easy           | 7              | 2            |
| acceptable     | 2              | 3            |
| difficult      | 4              | 0            |
| very difficult | 0              | 0            |

**Have you used any other type of eye protection for glare when riding e.g. a helmet peak, sunglasses or sun strip**

|     | General public | Professional |
|-----|----------------|--------------|
| Yes | 22             | 14           |
| No  | 6              | 0            |

### What?

- Sunglasses (32 people responded)
- Sunglasses & Helmet peak
- Sunglasses - on road Peak - off road
- Sunglasses under tinted visor
- all above. peak rubbish sunglasses rubbish, sun strip ok but might as well have tint

### Comments

- I don't like riding with sun glasses under a helmet
- Used to prevent glare during sunny conditions
- Very good and can be removed easily if visibility decreases
- As already stated, they are uncomfortable to wear (bridge of nose/above ears) Could cause injury in impact
- Helmet peak used on off road motorcycle. use sunglasses during daylight on regular basis
- Glasses are best option for me, but after a long time riding they become uncomfortable.
- regular use in bright sun conditions
- To stop sun glare
- Ease of removal & can be worn at your journeys end i.e. race meetings etc.
- It improves your vision and alert
- very good

- cutting of glare

**What were the benefits of using these?**

- Reduced glare in bright sunshine
- easier to change than a visor
- avoid glare
- Reduction of glare
- Reduce glare for sun/lights but this is counteracted by lack of comfort
- lass eyestrain.
- Reduce glare etc.
- Easier to store i.e. in your pocket can be removed easily when it goes dark
- reduces glare
- They mist up
- they are uncomfortable under a crash helmet digging in your ears and nose
- Only having to remove as the light falls also under ground car parks which we do a lot of work in
- Reduces light - comfort
- Eye protection with visor up
- wears spectacles as well so can replace specs with corrective sunglasses
- convenient if caught out be poor visibility
- good visibility
- so easy t take off
- reduce glare
- Multi purpose i.e. useful off the bike. Mine are prescription sunglasses
- reduce glare
- reduce glare
- reduces glare enough to be able to see - legal tint isn't enough to reduce enough
- reduce glare
- peak loos rubbish and not effective. Glasses not comfy
- reduce glare
- reduce glare
- reduces glare
- reduce glare
- Easy to remove when necessary
- Offer some problems to eyes without steaming up and allows air to filter when hot. e.g. slow moving
- reduce glare

**Were there any disadvantages to using these?**

- Problems when entering shadows etc.
- can be uncomfortable under the helmet padding
- slightly uncomfortable
- Glasses do not fit particularly well in helmets
- Discomfort

- Only if cleaned properly
- No provided not too dark tint
- Tinted visors be made legal for daytime riding
- Change visor when scratched use a fogcity shield inside visor for misting
- I have tried many different types of motorcycle helmet makes and up to now none of them have a very good anti misting system. I am currently using the shoei A-V this has a good visor easy to remove and the best anti fogging
- I think that we could look at some form of demisting system that works all the time and is cheap
- Not really
- cant take off when riding
- same as wearing glasses
- not really
- cant take off when riding
- tight fit in helmet
- Need to keep safe when not in use. One is thrown into darkness going through a tunnel or dark wooded area
- move around on face, not designed to fit within helmet
- not if wear proper sports sunglasses - wrap around (otherwise get blind spots)
- remember take sunglasses off first before helmet
- makes head hurt due to pressure of helmet after time
- Wrong that not legal - should be legalised. Need more information so everyopne knows what is what
- Problems in tunnels or darker areas - see less also glasses mist up ore often than visor
- look horrible
- Have to carry around
- risk of damage to eyes as not high impact awkward to take off if sunglasses in tunnel ate when riding.

**Do you have any other comments about tinted visors/goggles, scratches or misting/fogging?**

- I have now swapped to using contact lenses because of problems with spectacles steaming up. The only thing which seems to prevent fogging is application of washing up liquid to the inside face of the visor but it needs to be done prior to every days use
- a lot of sports bike rider, I suppose, wear them for other reasons other than anti-glare. i.e. image, pose
- Personally, I find misting /Fogging more of a problem than glare
- I believe that tinted visors up to 75% tint should be legal for use during daylight, as they are a great benefit. Most helmet manufacturers have visor fitting/removing systems which are easy to operate some can be changed whilst still wearing this helmet
- Scratched or poorly maintained visors/goggles are the main cause of visibility reduction. I do not feel that dark/tinted visors if used safely are any risk and would be preferable to wearing sunglasses
- there are plenty of anti fog products on the market now, some are easy to use, some work well i.e. fog shield, Bob Heath anti fog spray. tinted visors are now seen by many young riders as a fashion statement rather than being practical .
- Let rider decide what's best for them

- Tear-off good option 3 @£5.00 take off in dark & use up to 12 times you can use more for extra tint
- Scratches need throw away as soon as happens. Tinted visors if used properly are good. Crazy that legal to ride with clear visors and sunglasses at night, yet not legal to use dark visor in sun
- Can remove at night time . Should be legalised darker visors
- Nice to make steam-up visor and scratch resistant visor - be prepared to pay more as would be value for money
- scratches are big problem have to replace visor as can be distracting. Have to be prepared to change tinted visor if using one
- much nicer not to have tinted visors
- should legalise dark visor
- tinted visors can be seen as intimidating to other people
- Tinted visor might reduce contrast if sun goes in, effects all vision, but would be good in sunny weather
- I don't think eye protection has moved on very much since the days of motorcycling unlined clothing and helmet protection.
- Prescription glasses are fiddle to take on and off and are susceptible to damage by taking helmet off before removing glasses etc.

## Visor usage survey

I am conducting a survey on behalf of Loughborough University who are undertaking research into the design and use of motorcycle visors. Would you be willing to spend a few minutes answering questions on this subject?

1. If yes, **note time** and proceed with the questions below.
2. Is it possible that I could take a **reading** from your visor. This device will not damage your visor. It merely provides us with an indication of the amount of light which goes through your visor which is influenced by things like abrasion, dirt build up, etc.  
*(If it is greater than 80%, go to 7)*
3. Note if the visor is marked for **daytime use** only. 
4. **How old** is your visor?
5. Do you **carry a spare visor** for this helmet?
6. Is it the **same** as this one – or is it **darker** or **lighter**?  
*(Measure the spare visor)*
7. On average how many **miles** do you travel each year on your motorcycle?
8. How often do you ride in the **rain, darkness, bright sunlight, fog/mist**?  
*(Show rating scale - Never, Rarely, Sometimes, Often).*
9. Do you think that you will be **arriving home** tonight at dusk or later?

**THANK THE RESPONDENT FOR THEIR TIME.**



## **Veiling glare luminance trials**

### **1.0 Introduction**

Light passing through vehicle glazing or eye protection is predominantly caused to scatter by abrasion and contamination of the material's outer surfaces. This results in areas of veiling glare across the road scene and reduces the contrast of target objects. Veiling glare can be thought of a mist, which impedes the ability to view items in the road scene. Typical situations in which veiling glare can be observed are low sun conditions when the windscreens washes/whites out and at night when faced with an opposing vehicles headlamps. Additional factors, such as low ambient light levels, low luminous transmission properties, large angles of inclination from normal, as well as driver's age, all serve to further reduce target object contrast. In order to assess the effects of abrasion and contamination, the threshold levels of veiling glare luminance at which targets are obscured from view need to be identified.

The following test procedure serves to identify the levels of veiling glare luminance that cause target objects to be obscured when viewed through glazing and eye protection materials of various luminous transmission properties and under various ambient lighting conditions.

The model road facility was modified such that an adjustable source of veiling glare could be applied uniformly over the road scene. As veiling glare luminance was increased, effectively reducing a target's contrast, subjects were requested to inform the experimenter when a target object was no longer visible or, conversely, when a target object became visible as the glare luminance was decreased.

### **2.0 Test Variables**

#### **2.1 Target Objects**

The target objects presented in the road scene were a 1:20 scale adult male pedestrian of 95<sup>th</sup> %ile height and a scaled 20cm flat disc, each with a uniform 20% reflectivity. Pedestrian or disc targets were presented at one position corresponding to road centre at 73m - an approximate stopping distance (thinking + braking distance) for a vehicle travelling at 60mph.



## 2.2 Test Materials

Targets in the road scene were viewed through materials of different luminous transmission properties. The materials and their luminous transmission properties are shown in Table 1.

**Table 1: Materials used in work programme**

| <b>Material</b>  | <b>L.T.</b> |
|--|-------------|
| No material.<br><i>(For all conditions, targets were viewed through the clear glass sheet on which the veiling glare was projected. This was considered to have negligible effect on luminous transmission).</i> | 100%        |
| Toughened glass side window -  | 74.5%       |
| Lexon coated thin gauge polycarbonate motor cycle crash helmet visor   | 51%         |
| Toughened glass side window (Pilkington Optikool) with a <i>smoke bronze</i> tint film applied.  | 33.4%       |
| Toughened glass side window (Pilkington Optikool) with a <i>midnight</i> tint film applied.  | 19.6%       |

## 2.3 Ambient Light Levels

Four ambient lighting conditions, 'bright daylight', 'cloudy day', 'low sun' and 'unlit road' were replicated in the model road.

## 2.4 Trial Participants

Twenty, current UK driving licence holding participants (6 male and 14 female) whose ages ranged from 22 to 75 years (mean age of 49 years, SD 14.6) were recruited from ICE's Ergonomics database.

## 2.5 Test apparatus

In order to produce an adjustable and controllable level of veiling glare luminance over the scene in the model road, a light source was directed through a neutral density filter on to an inclined, transparent glass sheet. To produce the necessary range of glare intensities, applicable to all ambient lighting conditions, the light source consisted of either a 200W lamp or a 500W lamp. Refer to Figure 1.

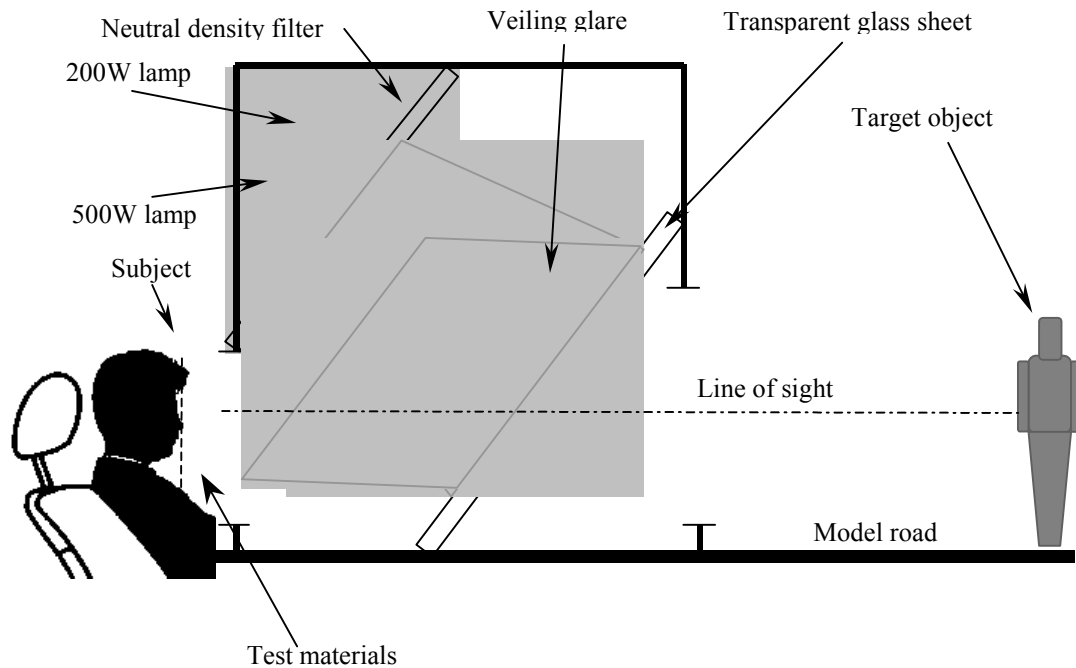

**Figure 1: Test apparatus**

The lamp's intensity was controlled via a rotary rheostat (0-1000 graduations) operating over two resistance ranges, designated 'high' and 'low'. With this apparatus the luminance of the veiling glare could be finely adjusted up to  $\approx 10,000 \text{cd/m}^2$ .

## 2.6 Test methodology

For each of the ambient lighting conditions and viewed through each of the test materials, participants were presented in a randomised order with disc target or pedestrian target positioned in the road at a distance of 73m. Participants were requested to indicate when a target either became obscured or became visible as the experimenter increased or decreased respectively the luminance of the veiling glare. For each target presentation, two increasing and two decreasing luminance readings were taken with the average of the four being recorded as the threshold.

Images of the model road scene are shown below with examples of the view through different test materials and with different levels of veiling glare luminance applied. Although some clarity has been lost, due to the resolution of the images, they serve to illustrate the effect achieved. Refer to Figure 2.

Bright Sunny Day ambient lighting condition

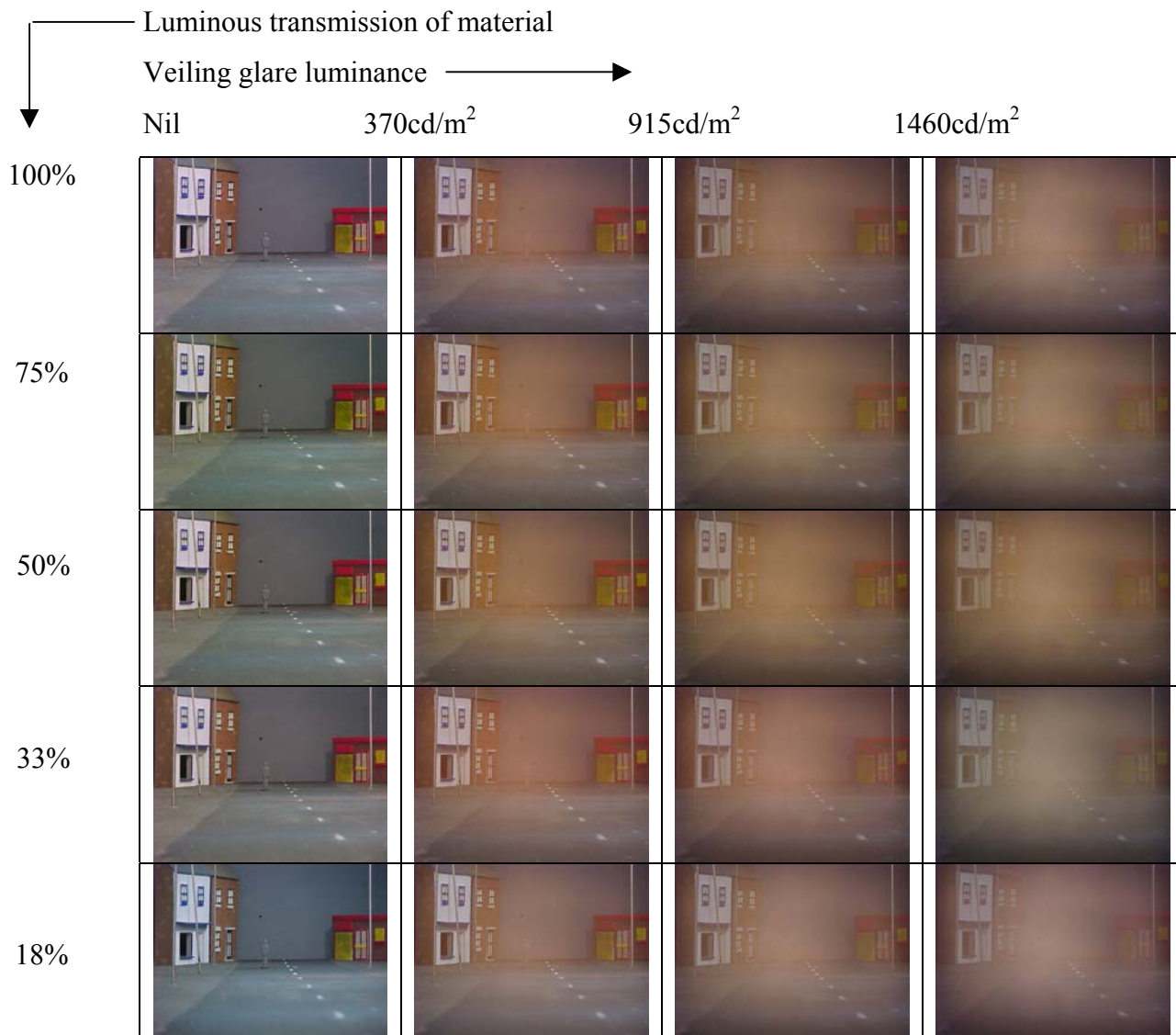

**Figure 2: Illustration to show the combined effect of veiling glare luminance and luminous transmission on the model road scene**

### 3.0 Results/Findings

When the mean luminance of the veiling glare required to just obscure/detect a target object is plotted against the luminous transmission of the material the scene is being viewed through and for each ambient lighting condition, then the following effects are observed. Refer to Figures 3 and 4.

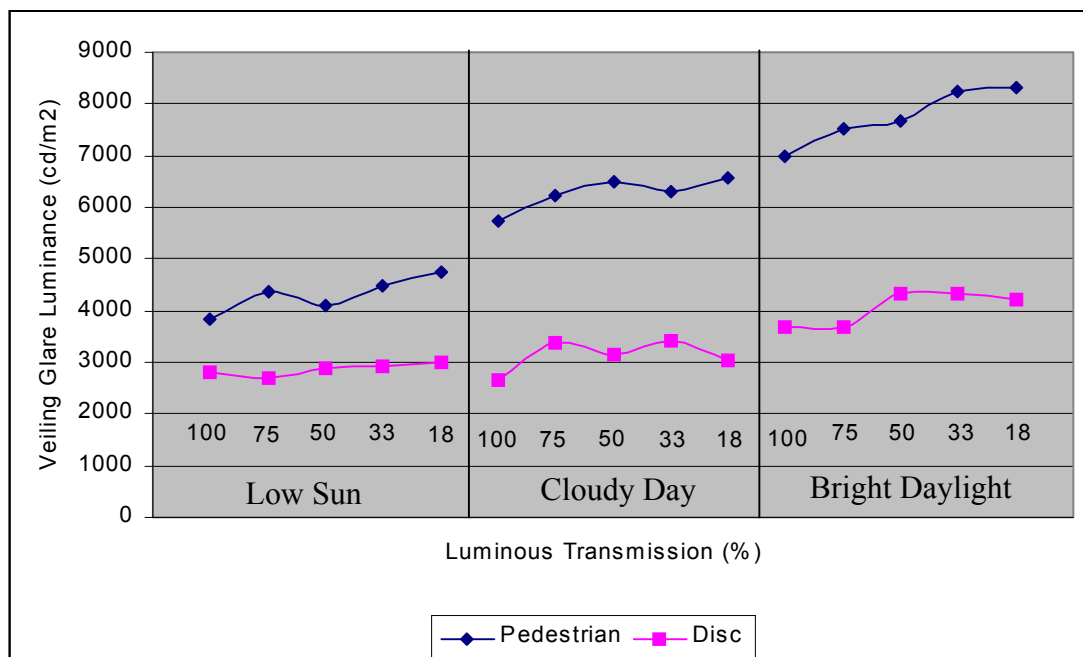

**Figure 3: Threshold levels of veiling glare luminance according to ambient lighting condition and level of luminous transmission**

Figure 3 shows that as ambient lighting increases, greater levels of veiling glare luminance are needed to obscure targets from view. It can also be seen that larger targets (the pedestrian compared to the disc) also need greater levels of veiling glare luminance to obscure them from view.

Figure 3 also show a trend for greater levels of veiling glare luminance to be required to obscure targets for lower luminous transmission materials. Under daytime ambient conditions, it requires less veiling glare luminance to obscure or ‘white-out’ a target when viewed through a material of 100% luminous transmission compared to those of 19.6%. Under night-time ambient lighting conditions, as shown in Figure 4, this situation is reversed since more veiling glare luminance is required to obscure targets viewed through materials with 100% luminous transmission than those of 19.6%.

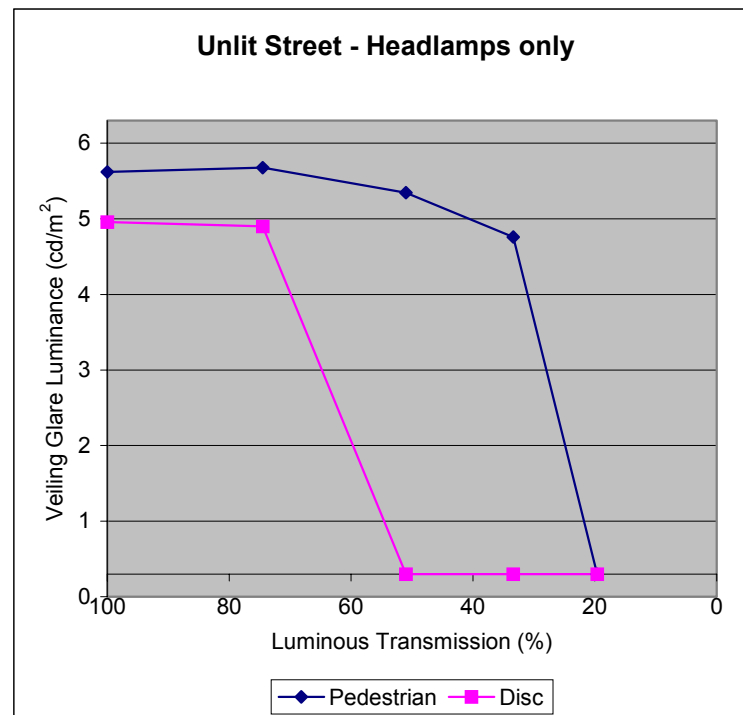

**Figure 4: Threshold levels of veiling glare luminance for different levels of luminous transmission under night-time ambient lighting conditions with no streetlighting.**

#### 4.0 Conclusions

Since the windscreen is not interchangeable between day and night-time conditions, consideration needs to be given to the worst case condition, night-time with vehicle head lights only, where veiling glare has most influence. Using the worst case condition of the smaller disc target and the required minimum luminous transmission for windscreens of 75%, the level of threshold veiling glare luminance of 5cd/m<sup>2</sup> for the night-time with car headlights condition can be used to estimate levels of abrasion and internal windscreen contamination which may degrade driving performance. (For installed light transmission, luminous transmission levels need to be reduced by 10% suggesting that a 3.33cd/m<sup>2</sup> level of threshold veiling glare luminance is used).

These findings, whilst in themselves significant, are of great importance when applied to the results of the abrasion and contamination work programmes.

## The Lazer Revolution helmet



The Lazer Revolution has an integral sun shield which can be raised and lowered as required. It is located between the rider's eyes and the clear visor. This is activated by way of a slider on the top of the helmet and, according to the manufacturers' literature, can be used one handed by a gloved hand in less than a second.





## **Additional considerations regarding motorcycle helmet and visor design**

The following list is based on personal comment of/from, which it is believed arise from the lack of a British Standard which deals with the performance of helmets and visors as a combined system. (Some of these issues have been identified as worthwhile by the riders surveys.) It is the opinion that none of the issues apart from sun glare from the lack of a peak - are considered to be easily solvable.

### **Misting**

From rider's breath; super-saturation of atmosphere; temperature difference across visor; poor seal of visor letting rain in behind it. May affect inner surface of visor; rider's spectacles. As related to ventilation: especially misting of spectacles.

### **Sun glare from lack of peak**

Half tinted visor now banned. As related to aerodynamics: peak no doubt generally abandoned for aerodynamic reasons. Most riders who use helmet with peak above about 60mph probably do so behind a screen, or the screen blade of a fairing.

### **Retention of visor in place**

Sudden flipping up of visor when wind catches it: wrenches rider's head back: can occur when rider leaves built-up area with visor still slightly open for ventilation to prevent misting at traffic lights

### **Aerodynamics**

Inability of rider to look over shoulder when wind in particular direction.

The goal of achieving improvements in the aerodynamic performance of helmets has been pursued by scientists and engineers since at least Prof Bertil Aldman's design of the Meno helmet in the early 1960s. Yet so far, the aerodynamic performance of helmets as sold on the market has only improved in detail.

### **Hearing loss**

From wind noise as related to aerodynamics



**Ventilation**

The reputed possibility that Carbon Dioxide may build up within the helmet, displacing Oxygen in proportion: so diminishing the wearer's mental performance

**Screen**

There is a third determining factor in the combined performance of helmet and visor, namely whether the rider is riding behind a screen and, if so, the design of the screen. The factor further complicates the issues to the degree that it is unlikely that a universal solution of a number of the issues is possible

PPAD 9/33/39

Field of vision  
(A-pillar Geometry)  
- a review of the needs of drivers

Final report

*Prepared for:*

The Department of the Environment,  
Transport and the Regions

*Prepared by*

Claire Quigley  
Sharon Cook  
Richard Tait

© January 2001

## Executive Summary

It is the aim of the Department for Transport, Local Government and the Regions (DTLR) to provide a safe transport network. Driver vision has been identified as an important determinant of this and factors that impede it require further investigation.

This study was commissioned to identify the problems associated with restricted visibility for vehicle drivers, in particular the consequential risk to road safety of changes in A-pillar size and position, driven by the need for improved structural and aerodynamic performance, which can restrict driver vision.

The experimental trials supported the findings of the literature review and the driver survey that A-pillars do impede the driver's forward field of view. It was shown that:

- Approximately one third of all the targets presented in the vicinity of the A-pillar were not detected.
- A-pillar obscuration is a greater problem in newer, as opposed to older, cars (although this is only statistically significant for viewing past the off-side A-pillar).
- If drivers make the effort to 'look around' their A-pillars the visual problems caused by A-pillar obscuration can be significantly reduced. However such a strategy cannot be relied upon and may be unsafe to encourage if the driver should also be concentrating on the road ahead.

The study therefore shows that there are safety disbenefits due to the trend for wider A-pillars. Further research work into A-pillar design should be considered in terms of the drivers' field of view which may include:

- the use of accident statistics to quantify the effect of A-pillar design on driver vision,
- a study to investigate the relationship between target detection and obscuration angle (ranging from 0° to 6°), this may also include an investigation into the location of the A-pillar in the drivers' visual field,
- creating awareness amongst interested parties of the visual effects of increased A-pillar thickness.

## Table of Contents

|  |           |
|--|-----------|
| <b>Executive Summary .....</b>   | <b>i</b>  |
| <b>1.0 Introduction .....</b>  | <b>73</b> |
| <b>2.0 Research review.....</b>  | <b>74</b> |
| 2.1. A-Pillar Obstructions.....  | 74        |
| 2.2. Design and measurement of A-pillars.....                            | 74        |
| 2.3. The effect of A-pillar design .....                                 | 75        |
| 2.4. Conclusion to the research review .....                             | 76        |
| <b>3.0 Interviews with drivers .....</b>                                 | <b>77</b> |
| 3.1. Car driver experiences and opinions .....                           | 77        |
| 3.2. Conclusion to the interviews.....                                   | 78        |
| <b>4.0 A-pillar obscuration - Survey of cars .....</b>                   | <b>79</b> |
| 4.1. Aim of the survey .....   | 79        |
| 4.2. Survey of new cars (including windscreen swept area and rake) ..... | 79        |
| 4.3. Methodology .....   | 80        |
| 4.4. Survey of older cars.....   | 83        |
| 4.5. Results/findings.....   | 83        |
| <b>5.0 A-pillar obscuration trials .....</b>                             | <b>87</b> |
| 5.1. Methodology .....   | 87        |
| 5.2. Results/findings.....   | 92        |
| <b>6.0 Discussion and conclusions.....</b>                               | <b>98</b> |
| 6.1. Changes in A-pillar design.....                                     | 98        |
| 6.2. Extent of obstruction to forward visibility .....                   | 98        |
| 6.3. Comparative performance of older and newer vehicles.....            | 98        |
| 6.4. Compensation of A-pillar obscuration by driver behaviour.....       | 99        |

- 7.0 Recommendations ..... 100**
- 7.1. A-pillar design..... 100
- 7.2. Future work ..... 100
- 8.0 References ..... 102**
  
- Appendix 1: Directives, Regulations and Standards ..... 103**
  
- Appendix 2: Car Driver’s Questionnaire..... 108**
  
- Appendix 3: Driver vision questionnaire data ..... 115**
  
- Appendix 4: Survey of windscreen swept area..... 119**

## 1.0 Introduction

It is the aim of the Department for Transport, Local Government and the Regions (DTLR) to provide a safe transport network. Driver vision has been identified as an important determinant of this and factors that impede it require further investigation.

The objective of the work was to identify the problems associated with restricted visibility for vehicle drivers, in particular “the consequential risk to road safety of changes in A-pillar size and position, driven by the need for improved structural and aerodynamic performance, which can restrict driver vision”. The specific areas investigated were:

- the actual differences in A-pillar design between older and newer cars,
- the relative obscuration of off-side and near-side A-pillars in older versus newer cars,
- the ability of drivers to compensate for A-pillar obscuration by looking around them.

## **2.0 Research review**

In addition to the research, a review was undertaken of the directives, regulations and standards pertaining to A-pillar obscuration. A précis of the legislative literature can be found in Appendix 1.

### **2.1. A-Pillar Obstructions**

Along with the rear view mirror, the bonnet and the wings, the A-pillars have been identified as the main obstructions to the visual field from the driver's seat (Allen, 1996). An object on collision course with the vehicle may be obstructed by the A-pillars, causing the object to be overlooked until it is too late to avoid it. Therefore, the design of the A-pillar is an important factor when trying to maximise the drivers' forward field of view.

### **2.2. Design and measurement of A-pillars**

Haslegrave (from Peacock and Karwoski in "Automotive Ergonomics", 1993) discusses binocular vision and how it can have "very little effect on the view of distant objects... but can have a considerable effect on obscuration caused by objects in the near field of view". This can affect the design of A-pillars, because if the width of the A-pillar is less than the width between the eyes, distant objects will be visible, and only a portion of the road directly beyond the pillar will be obscured. Directive 77/649/EEC deals with the binocular obscuration of the A-pillar and takes into account both eye and head turn when assessing the extent of obscuration.

There are a number of techniques which can be used to measure direct field of view. The first involves an observer describing the view while sitting in a vehicle, the second uses a camera instead of an observer placed in the position of the driver's eye, which provides a permanent record. The third technique uses lights to represent the driver's eyes, so wherever an object obstructs the field of view, including the A-pillars, the light is obscured. The area of obscuration of the A-pillars or any other objects can be measured using a reference grid marked on a screen which surrounds the vehicle. An alternative to using this sort of laboratory testing is to use computer based modelling systems, such as SAMMIE (Systems for Aiding Man-Machine Interaction).

It should be remembered that visual requirements must be incorporated with other design necessities. Most importantly, the positioning and thickness of the A-pillars is essential to the mechanical strength of the vehicle as they form part of the cage which protects the vehicle occupants in the incident of impact or rollover. Therefore, visual requirements should be given consideration at the earliest stage possible in the design process, as this will avoid complex modifications later on.

Fowkes (1986) describes the legislation set out for forward field of view in Directive 77/649/EEC. This includes a limit set for the binocular obscuration of each A-pillar, which should not exceed  $6^\circ$  from two eye points rotated around a simulated neck pivot.

A-pillars have been described as being potentially able to restrict essential visibility of road signs, oncoming vehicles and vulnerable road users during driving (Porter and Stearn, 1986). Therefore, a technique to quantify forward field of view was developed. Participants in a trial evaluating the design of a prototype car, which compared with the designs of four market competitors, were given a SAMMIE generated visibility grid, and were asked to draw on areas which were obscured by objects, such as the A-pillars. Comparisons of all the completed visibility charts from each vehicle, and then from each participant, were undertaken in order to quantify the angle of A-pillar obscuration. The use of this method revealed that the angle of lateral visibility was significantly less in the prototype car. This resulted in the A-pillars of the vehicle in question being moved further around the side of the windscreen and also being reduced in width by removing its thick trim to improve forward visibility.

Fosberry and Mills (1956) measured windscreen pillar obscuration angles in various cars and found a variation from  $2^\circ$  to  $12^\circ$ . A comparison of these pillar widths were made with the requirements at the time, which revealed that only five out of the fifteen conformed to the recommended requirements and one failed to comply by a negligible amount.

### **2.3. The effect of A-pillar design**

Bhise (undated) conducted an investigation into the “visual field requirements of vehicles in freeway merging situations”, looking at the “search and scan behaviours” of drivers.



This found that the A-pillar on the driver's side caused the greater field of impairment and that between 2 and 4% of vehicles were found to be in this obscured area at the time of measurement.

The effect of A-pillars on a driver's field of view is not limited to direct obscuration. Chong and Triggs (1989) investigated the effects of detecting targets when in the vicinity of a window post, such as an A-pillar. It was concluded that visual performance can be influenced in two ways. Firstly, inappropriate visual accommodation towards the post can occur (i.e. vision will be accommodated at the distance of the post rather than the distance of the targets beyond), although this effect can be reduced when the line of gaze is greater than 1° from the post. Secondly, the presence of a target up to 1-2 degrees from the edge of the post results in them being detected less easily.

A study by Roscoe and Hull 1982, (in Chong and Triggs) found that targets were poorly detected when positioned close to the edges of an intervening post and that the detection of distant targets was affected by posts with widths greater than the observers interocular distance.

#### **2.4. Conclusion to the research review**

Although an extensive literature review was conducted, no explicit rationale for current levels of visibility were identified.

It appears that, as well as causing direct obscuration of part of a driver's forward field of view, A-pillars interfere with the detection of objects in their close vicinity and could cause inappropriate visual accommodation towards the A-pillar rather than distant objects. As no rationale for current visibility levels was identified, and as from the few studies found, there was an indication that A-pillars do affect the detection of objects in close vicinity, it was decided that further work would be required to investigate the effects of changing A-pillar dimensions on object detection. This would be achieved by undertaking a survey to identify the major differences in A-pillar dimensions between older and newer cars, and undertaking trials to determine the degree to which any changes between older and newer cars has lead to increased obscuration.

### 3.0 Interviews with drivers

To help ensure that the scope of the testing programme which was planned for Phase 2 of the project addressed all the key issues, a survey was undertaken to seek drivers views on the field of vision through car windows.

Face-to-face interviews were conducted with a random selection of drivers in the Loughborough area to seek information on their experiences of, amongst other aspects, the effects of A-pillar design on visibility.

A copy of the questionnaire (see questions 2.9 to 2.11 for relevant questions) and the data tables are provided in Appendices 2 and 3.

#### 3.1. Car driver experiences and opinions

Interviews were completed with 30 drivers (14 male, 16 female).

Sample details are given in Table 1 and Table 2:

**Table 1: Age and years of driving**

|         | <b>Age</b> | <b>Years driving</b> |
|---------|------------|----------------------|
| Average | 42         | 23                   |
| Minimum | 21         | 4                    |
| Maximum | 72         | 54                   |

**Table 2: Age of vehicle**

| <b>(Years)</b> | <b>Age of car</b> | <b>How long owned</b> |
|----------------|-------------------|-----------------------|
| Average        | 7.3               | 2.9                   |
| Minimum        | 2                 | 0.1                   |
| Maximum        | 15                | 13                    |

Of the 30 drivers interviewed, 11 said that the A-pillar sometimes or often restricts their vision out of the car and 14 stated that they sometimes or often had to move their head to see round it.

Two drivers reported near misses that they had experienced as a result of A-pillar obscuration. One had experienced a number of near misses at T-junctions in several cars and the other had failed to see an approaching car at a roundabout.

### **3.2. Conclusion to the interviews**

It appears from the responses that A-pillars can restrict drivers' vision out of the vehicle and can potentially cause drivers to detect objects slower than what would otherwise be possible. This in turn could result in an increased possibility of an accident occurring.

The ages of the cars in this small sample means that many of the respondents cars will not have the newer design of A-pillar, which tends to be thicker and more raked. It is therefore difficult to determine from this survey if obstructions to vision caused by A-pillars are worse or better with newer designs. This aspect has been addressed in Phase 2 (i.e. the experimental work).

## **4.0 A-pillar obscuration - Survey of cars**

### **4.1. Aim of the survey**

Prior to field of view trials being undertaken, a survey of newer and older cars was conducted to ensure that representative vehicles were used.

### **4.2. Survey of new cars (including windscreen swept area and rake)**

A survey of a sample of new model vehicles was undertaken to determine A-pillar widths, eye-to-A-pillar geometries and the resultant degree of obscuration imposed.

A total of twenty-seven vehicles between 0 and 3 years old were surveyed. They were the most current models from a representative range of classes and makes (see Table 3) many of which had been included in the crash tests carried out by the European New Car Assessment Programme (Euro NCAP).

**Table 3: The range of vehicles measured in the survey**

| Make        | Superminis | Small Family Cars | Large Family Cars | Executive Cars                      | MPV           | Other (e.g. Sports, 4WD) |
|-------------|------------|-------------------|-------------------|-------------------------------------|---------------|--------------------------|
| Alpha Romeo |            |                   | 156               |                                     |               |                          |
| Audi        |            |                   | <b>A4</b>         | <b>A6</b>                           |               |                          |
| BMW         |            |                   |                   | <b>5 series,</b><br><b>7 series</b> |               |                          |
| Citroen     |            | <b>Xsara</b>      |                   |                                     |               |                          |
| Daewoo      | Matiz      |                   |                   |                                     |               |                          |
| Fiat        | Seicento   |                   |                   |                                     |               |                          |
| Ford        | Ka         | <b>Focus</b>      | <b>Mondeo</b>     |                                     |               |                          |
| Honda       |            |                   | Accord            |                                     |               |                          |
| Jaguar      |            |                   |                   |                                     |               | XK8                      |
| Jeep        |            |                   |                   |                                     |               | Grand Cherokee           |
| Land Rover  |            |                   |                   |                                     |               | Discovery                |
| Nissan      |            |                   | <b>Primera</b>    |                                     |               |                          |
| Peugeot     | 206        |                   | <b>406</b>        |                                     |               |                          |
| Renault     |            |                   | <b>Laguna</b>     |                                     | <b>Espace</b> |                          |
| Rover       |            | 200               |                   |                                     |               |                          |
| Seat        |            |                   |                   |                                     | Alhambra      |                          |
| Skoda       |            |                   | Octavia           |                                     |               |                          |
| Toyota      | Yaris      |                   |                   |                                     |               |                          |
| Vauxhall    |            | <b>Astra</b>      |                   |                                     |               |                          |
| VW          |            |                   | <b>Passat</b>     |                                     |               |                          |
| Volvo       |            |                   | V40               |                                     |               |                          |

**Those in bold** – have featured in the Euro NCAP crash test programme.

### 4.3. Methodology

To be able to carry out a comprehensive assessment of the variation in A-pillar geometry in new cars, the measurements taken included the dimensions of each A-pillar, their location in relation to the driver's eye point and the ground, the driver's eye point in relation to the ground, and windscreen and A-pillar rake. A full list of the measurements taken and their location can be seen in Table 4, Figure 1 and Figure 2.

**Table 4: The measurements taken in each vehicle to assess A-pillar obscuration and rake.**

|    | Measurement description  | Location in Figures 1 & 2* |
|----|--|----------------------------|
| 1  | A-pillar length  | A                          |
| 2  | Distance between A-pillar centre points  |                            |
| 3  | Height of A-pillar base above ground   | C                          |
| 4  | Height of A-pillar top above ground  | D                          |
| 5  | Internal, horizontal obscuration thickness - off-side**                            | E                          |
| 6  | Internal, horizontal obscuration thickness - near-side**                           |                            |
| 7  | A-pillar inclination from vertical   | F                          |
| 8  | Windscreen inclination from vertical   |                            |
| 9  | Seat back angle from vertical  |                            |
| 10 | Eye point marker to A-pillar centre point - off-side                               | G                          |
| 11 | Eye point marker to A-pillar centre point - near-side                              | H                          |
| 12 | Height of eye point marker above ground  |                            |
| 13 | Longitudinal distance from eye-point marker to A-pillar centre                     | J                          |
| 14 | Lateral distance from eye-point marker to A-pillar centre                          | K                          |
| 15 | Side window inclination from vertical  |                            |
| 16 | Angle of obscuration - off-side<br>(calculated using 5(E) and 10(G), not measured) | L                          |
| 17 | Angle of obscuration - near-side(calculated using 6 and 11(H), not measured)       |                            |

\* where relevant.

\*\* this includes any obscuration band (e.g. black shading) around the edge of the windscreen.

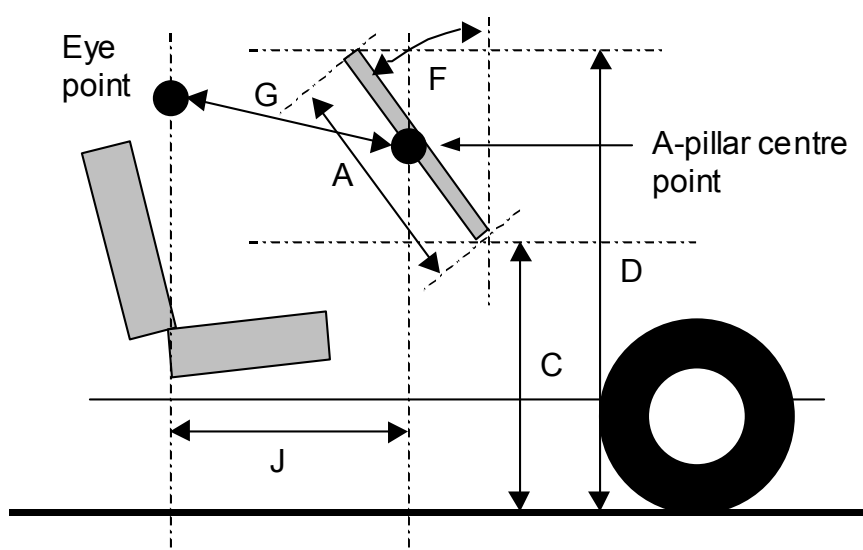
**Figure 1: Side elevation showing driver's seat and A-pillar**

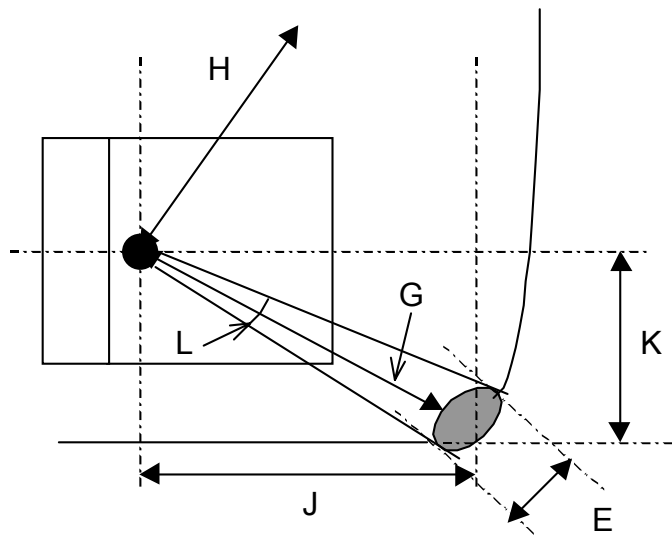

**Figure 2: Plan view of driver's seat and off-side A-pillar**

For each vehicle, the driver's seat was adjusted to the lowest most rearward position. An SAE H-point manikin (of 50-percentile adult male height) was used to determine a reference for the eye points as detailed in Directive 77/649/EEC.

Measurements were then taken from which the extent of A-pillar visual obscuration could be calculated. In addition, measurements which could be used to calculate windscreen wiper swept area of each car were recorded and are displayed in Table 5 and Figure 3. The data calculated from these additional measurements are reported in Appendix 4.

**Table 5: Windscreen features which were measured for each vehicle to assess the windscreen wiper swept area.**

| Measurement description   | Location in Figure 3* |
|---|-----------------------|
| Depth below windscreen lower edge of wiper drive shaft              | L                     |
| Distance from windscreen's off side edge to first wiper drive shaft | M                     |
| Distance between wiper drive shafts                                 | N                     |
| Distance of second wiper drive shaft from windscreen's near side    | O                     |
| Length of off side wiper arm  |                       |
| Length of near side wiper arm                                       | Q2                    |
| Length of off side wiper blade                                      | R1                    |
| Length of near side wiper blade                                     | R2                    |
| Height of windscreen top edge (centre) above ground                 |                       |
| Height of windscreen bottom edge (centre) above ground              |                       |

\*where relevant

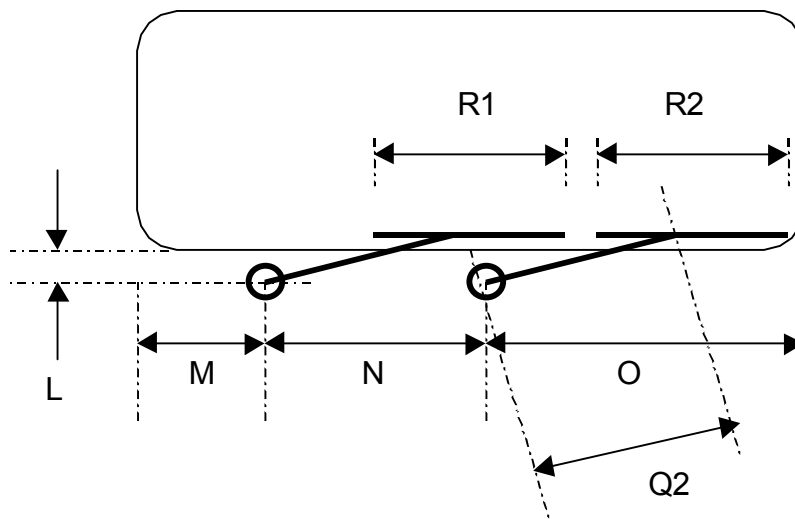

**Figure 3: Front elevation showing windscreen and wipers.**

#### 4.4. Survey of older cars

In addition, a further survey of 11 cars between 5 and 17 years old (i.e. pre Euro NCAP) was undertaken for A-pillar obscuration only. A list of these cars are displayed in Table 6.

**Table 6: The range of vehicles measured in the “older car” survey**

| Make     | Small Cars | Small Family Cars | Family Cars | Executive/Sports Cars |
|----------|------------|-------------------|-------------|-----------------------|
| BMW      |            |                   |             | 5 series              |
| Ford     |            | Escort            | Mondeo      |                       |
| Nissan   |            | Sunny             |             |                       |
| Peugeot  | 106        |                   | 309, 306    |                       |
| Vauxhall |            | Astra             | Cavalier    |                       |
| VW       |            | Golf              |             |                       |
| Volvo    | 480 GT     |                   |             |                       |

#### 4.5. Results/findings

The results of the two surveys were used to select cars for the A-pillar obscuration trials and to investigate the changes in A-pillar dimensions in new cars compared to older cars.



Table 7 and Table 8 show the summary of the measurements taken which were used to calculate A-pillar obscuration and compare A-pillar designs in older and newer vehicles.

**Table 7: The findings of the A-pillar obscuration survey of new cars.**

| Measurement description  | Mean | Minimum | Maximum |
|--|------|---------|---------|
| A-pillar length, mm  | 759  | 600     | 890     |
| Distance between A-pillar centre points, mm                        | 1298 | 1145    | 1565    |
| Internal, horizontal obscuration thickness - off-side, mm          | 113  | 85      | 135     |
| Internal, horizontal obscuration thickness - near-side, mm         | 140  | 105     | 165     |
| A-pillar inclination from vertical, °                              | 57   | 40      | 61      |
| Windscreen inclination from vertical, °                            | 59   | 41      | 63      |
| Eye point marker to A-pillar centre point - off-side, mm           | 857  | 727     | 1126    |
| Eye point marker to A-pillar centre point - near-side, mm          | 1260 | 1120    | 1435    |
| Longitudinal distance from eye-point marker to A-pillar centre, mm | 824  | 695     | 1100    |
| Lateral distance from eye-point marker to A-pillar centre, mm      | 292  | 260     | 360     |
| Side window inclination from vertical, °                           | 25   | 11      | 35      |

**Table 8: The findings of the A-pillar obscuration survey of older cars.**

| Measurement description  | Mean | Minimum | Maximum |
|--|------|---------|---------|
| A-pillar length, mm  | 685  | 590     | 805     |
| Distance between A-pillar centre points, mm                        | 1286 | 1213    | 1500    |
| Internal, horizontal obscuration thickness - off-side, mm          | 93   | 80      | 104     |
| Internal, horizontal obscuration thickness - near-side, mm         | 118  | 95      | 131     |
| A-pillar inclination from vertical, °                              | 55   | 51      | 59      |
| Windscreen inclination from vertical, °                            | 57   | 53      | 62      |
| Eye point marker to A-pillar centre point - off-side, mm           | 923  | 796     | 1020    |
| Eye point marker to A-pillar centre point - near-side, mm          | 1245 | 1175    | 1365    |
| Longitudinal distance from eye-point marker to A-pillar centre, mm | 859  | 755     | 952     |
| Lateral distance from eye-point marker to A-pillar centre, mm      | 278  | 234     | 342     |
| Side window inclination from vertical, °                           | 24   | 22      | 30      |

A statistical comparison<sup>1</sup> of measurements from older cars with new models found that compared to the old cars, newer cars had:

- Significantly longer A-pillars.
- Significantly greater internal horizontal obscuration angles (near and off-side).
- Significantly greater A-pillar and windscreen inclination from vertical.

<sup>1</sup>All data, in the survey and in the trials, was tested for statistical significance using both a chi-squared test and a two-tailed, paired t-test at 5% significance. Any apparent differences between conditions which are not significant are due to natural variability in the data and are not due to differences in A-pillar design.

- Significantly closer A-pillar to eye-point in rear most position (off-side only, direct, longitudinal and lateral).

From the information collected, obscuration angles resulting from both the off-side and near-side A-pillars were calculated using internal obscuration thickness and A-pillar to eye point distance measurements. This included any obscuration band around the edge of the windscreen, in line with the definition given in Directive 77/649/EEC (see Appendix 1). The mean obscuration angle of both off-side and near-side A-pillars was less in older cars than newer cars. This difference was found to be statistically significant, i.e. A-pillar obscuration angles have become significantly worse in newer cars than in older cars. However, it must be noted that comparisons were not with identical cars, i.e. many of the older cars were not old versions of the new cars.

To ensure a representative selection of vehicles were used in the trials, the extent of A-pillar obscuration (as defined in Figure 2) of the vehicles surveyed was ranked. Due to the resource constraints of the study, absolute measures of obscuration using the procedures given in the Council Directive were approximated by a more time efficient monocular method to obtain the rankings. For this reason the angles given in Table 9 are greater than those regulated. It was then decided that the cars with the least, most and mean overall A-pillar obscuration (i.e. the combined off-side and near-side obscuration) would be used in the obscuration trials. Therefore, of the cars in these categories available at the time of the trials, the Nissan Sunny (least), Ford Focus (mean) and Renault Laguna (most) were selected. This also allowed for comparison of older design cars (i.e. Nissan Sunny) with new designs (i.e. Ford Focus, Renault Laguna).

**Table 9: The variation in A-pillar obscuration angle from least to most obscuration (as calculated from Table 4 and defined in Figure 2)**

|             | OFF-SIDE        |            | NEAR-SIDE       |            | SUM OF OFF-SIDE AND NEAR-SIDE |             |
|-------------|-----------------|------------|-----------------|------------|-------------------------------|-------------|
| Least       | <b>Sunny</b>    | <b>5.4</b> | Discovery       | 4.4        | <b>Escort</b>                 | <b>10.8</b> |
|             | A4              | 5.5        | <b>480 GT</b>   | <b>4.6</b> | <b>Sunny</b>                  | <b>10.9</b> |
|             | <b>309</b>      | <b>5.8</b> | <b>Escort</b>   | <b>4.7</b> | A4                            | 11.0        |
|             | Espace          | 6.0        | <b>Cavalier</b> | <b>5.0</b> | <b>309</b>                    | <b>11.1</b> |
|             | A6              | 6.0        | <b>309</b>      | <b>5.2</b> | A6                            | 11.5        |
|             | <b>Escort</b>   | <b>6.1</b> | <b>Mondeo</b>   | <b>5.4</b> | <b>480 GT</b>                 | <b>11.6</b> |
|             | <b>Astra</b>    | <b>6.1</b> | A6              | 5.5        | <b>Astra</b>                  | <b>11.7</b> |
|             | <b>5 Series</b> | <b>6.2</b> | A4              | 5.5        | Discovery                     | 11.8        |
|             | <b>309.0</b>    | <b>6.5</b> | <b>309.0</b>    | <b>5.5</b> | <b>Cavalier</b>               | <b>11.8</b> |
|             | 156             | 6.7        | <b>Sunny</b>    | <b>5.5</b> | <b>309.0</b>                  | <b>12.0</b> |
|             | Accord          | 6.7        | <b>Astra</b>    | <b>5.6</b> | <b>5 Series</b>               | <b>12.2</b> |
|             | <b>Cavalier</b> | <b>6.8</b> | <b>Golf</b>     | <b>5.8</b> | <b>Mondeo</b>                 | <b>12.4</b> |
|             | <b>Mondeo</b>   | <b>7.0</b> | Mondeo          | 5.8        | Espace                        | 12.7        |
|             | <b>480 GT</b>   | <b>7.0</b> | <b>5 Series</b> | <b>5.9</b> | <b>Golf</b>                   | <b>12.8</b> |
|             | 523i            | 7.0        | 406             | 6.0        | 156                           | 12.9        |
|             | 728i            | 7.0        | 523i            | 6.1        | 523i                          | 13.0        |
|             | <b>Golf</b>     | <b>7.0</b> | Passat          | 6.1        | Accord                        | 13.1        |
|             | Seicento SX     | 7.1        | Focus           | 6.1        | 728i                          | 13.2        |
|             | Passat          | 7.1        | 728i            | 6.2        | Passat                        | 13.2        |
|             | Focus           | 7.2        | Primera         | 6.2        | Mondeo                        | 13.3        |
|             | Discovery       | 7.4        | 156             | 6.2        | Focus                         | 13.4        |
|             | Alhambra        | 7.5        | Seicento SX     | 6.3        | Seicento SX                   | 13.4        |
|             | Mondeo          | 7.5        | Accord          | 6.3        | Alhambra                      | 13.9        |
|             | Astra           | 7.6        | Ka              | 6.3        | Primera                       | 14.2        |
|             | 206             | 7.8        | Alhambra        | 6.4        | 406                           | 14.2        |
|             | 200             | 7.8        | <b>306</b>      | <b>6.4</b> | <b>306</b>                    | <b>14.3</b> |
|             | <b>306</b>      | <b>7.9</b> | Xsara           | 6.5        | 206                           | 14.5        |
|             | Octavia         | 7.9        | 206             | 6.7        | Ka                            | 14.7        |
|             | Primera         | 8.0        | Espace          | 6.8        | 200                           | 14.8        |
|             | Matiz           | 8.2        | Grand Cherokee  | 6.8        | Octavia                       | 14.8        |
|             | 406             | 8.3        | Yaris           | 6.8        | Astra                         | 14.8        |
| V40         | 8.3             | Octavia    | 6.8             | Matiz      | 15.3                          |             |
| Ka          | 8.4             | 200        | 6.9             | Yaris      | 15.4                          |             |
| Yaris       | 8.5             | XK8        | 7.0             | Xsara      | 15.4                          |             |
| Laguna      | 8.7             | Astra      | 7.2             | V40        | 15.5                          |             |
| XK8         | 8.8             | Matiz      | 7.2             | XK8        | 15.8                          |             |
| Xsara       | 8.9             | V40        | 7.2             | Laguna     | 16.0                          |             |
| <b>Most</b> | Grand Cherokee  | 9.4        | Laguna          | 7.3        | Grand Cherokee                | 16.2        |
| <b>Mean</b> |                 | <b>7.3</b> |                 | <b>6.1</b> |                               | <b>13.4</b> |

**Bold = more than five years old**

Not bold = less than five years old

## 5.0 A-pillar obscuration trials

Field of view (A-pillar) trials were undertaken to investigate the effect on driver's forward vision of the recent changes in the size and positioning of A-pillars. Concern has been expressed regarding the risk to road safety of these structures in terms of the blind spots they may cause and drivers' ability to compensate for them.

To obtain an overall view of how A-pillar thickness affects the level of driver's obscuration of their forward field of view, a laboratory-based trial was devised. The aim of the trial was to determine the extent to which different angles of A-pillar obscuration affect the detection of targets in the visual field in a number of different driving scenarios.

### 5.1. Methodology

#### 5.1.1. Equipment/variables

A full-scale, 180° wrap around, panoramic road scene was developed which consisted of enlarged (8' x 4') photographic images of a real road scene (i.e. a busy road junction), as displayed in Figure 4.



**Figure 4: View of the road scene**

Within an appropriate part of this scene a computer screen was positioned which was to be used for the road sign task in the first part of the trial. This will be explained in more detail later in this section.

Thirty LEDs, which were identical in terms of colour and intensity, were used as the targets for the participants to detect. It was ensured that these lights were conspicuous enough so that the only reason a participant could not see a target was due to it being obscured (i.e. by the A-pillar).

The targets were positioned around the areas in which the A-pillars could have caused an obstruction in all three chosen vehicles and a number were positioned either side of these areas. This also took into account seat positioning. The targets were positioned between 25° and 65° to the left of the driver's line of sight and between 15° and 47° to the right of the driver's line of sight. In general, they were between 2° and 5° apart, although in the critical areas (i.e. where the A-pillar could have caused obstruction) they were positioned no more than 2° apart. Table 10 and Figure 5 show the position of each target in relation to the driver's line of sight.

The vertical position of the targets also varied, with targets positioned from 5° below to 3° above the line of sight of the H-point manikin (this would vary slightly due to the height of each participant but the range of 8° would remain the same). However, all were in vertical positions where targets in the road scene would be expected to be seen. Figure 6 shows the vehicles used in the trials.

**Table 10: The location of the targets in relation to the driver's line of sight.**

| To the left of driver's line of sight |         | To the right of driver's line of sight |         |
|---------------------------------------|---------|--|---------|
| Target Number                         | Angle ° | Target Number                          | Angle ° |
| 1                                     | 65      | 15                                     | 15      |
| 2                                     | 63      | 16                                     | 17      |
| 3                                     | 61      | 17                                     | 19      |
| 4                                     | 59      | 18                                     | 20      |
| 5                                     | 57      | 19                                     | 22      |
| 6                                     | 55      | 20                                     | 24      |
| 7                                     | 53      | 21                                     | 26      |
| 8                                     | 50      | 22                                     | 28      |
| 9                                     | 46      | 23                                     | 30      |
| 10                                    | 42      | 24                                     | 32      |
| 11                                    | 38      | 25                                     | 34      |
| 12                                    | 33      | 26                                     | 36      |
| 13                                    | 30      | 27                                     | 40      |
| 14                                    | 25      | 28                                     | 42      |
|                                       |         | 29                                     | 44      |
|                                       |         | 30                                     | 47      |

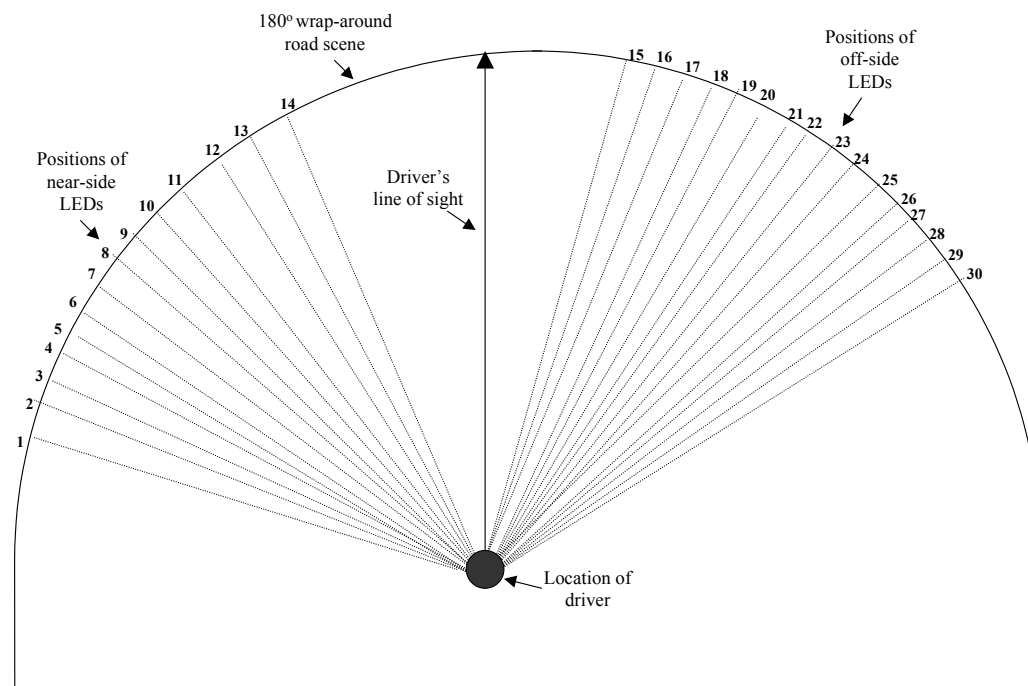
**Figure 5: Schematic view of the target locations in the road scene.**

**(a) Laguna****(b) Focus****(c) Sunny****Figure 6 (a) to (c): The cars used in the trials.**

### 5.1.2. Procedure

#### Task 1

The aim of task 1 was to investigate the effects of A-pillar thickness on the ability to detect nearby hazards when a driver's focus of attention is on the road ahead.

The participant was seated in the first vehicle and was asked to adjust the driving seat to a suitable driving position. The driver's eye point was then approximately aligned to the set eye point position marked out on the floor by pushing the car back or forth.

Once the participant was satisfied with their seat position, they were asked to don their seat belt. Prior to the start of the trial, it was ensured that the participant was familiar with the tasks they were about to carry out by undertaking a practice run. Once they were familiar with the procedure, the trial began. At random intervals in a random order, one of the thirty target lights was activated, which triggered the reaction timer (see Figure 7). Once the participant had detected the target, they were required to respond immediately by pressing a button which was attached to the steering wheel in the car, which in turn stopped the timer. The reaction time was then recorded. It was assumed that if the participant had not responded after five seconds, they could not see the target and this was recorded as a miss. This was repeated for all 30 targets.



**Figure 7: Examples of the target lights.**

To make the trial more representative of the driving task, the participants had to undertake a secondary task to prevent them from searching for targets and to keep their concentration on the “road” ahead. This task involved viewing road signs displayed on a screen positioned appropriately within the road scene (see Figure 8). Initially, a prompt screen consisting of one town name was viewed (Figure 8(a)). The participant was then required to look for this town in the following signs which appeared approximately every three seconds. Each sign consisted of a list of five towns which the participant had to check (Figure 8 (b)). If their town was present in the sign they had to use the indicators in the car according to the directional information given beside the town name.



**(a)**

**(b)**

**Figure 8 (a) and (b): The road sign task**

### **Task 2**

The aim of task 2 was to investigate the effect of A-pillar thickness on the ability of the driver to detect targets when actively searching for them, for example, at a road junction.



As with task 1, each participant was given time to familiarise themselves with the task they were about to undertake and once they were happy to continue, the trial began.

The participant was asked to concentrate on the road ahead. After random intervals, the participant was prompted by the experimenter to search for a target light which would be displayed somewhere on the road scene. However, to guard against false reporting, a target light was only activated on half the occasions a prompt was given and the other half were false alarms (i.e. a prompt was given but no light activated). Once they had decided whether there was a light present or not, they were asked to press the button mounted on the steering wheel and then let the experimenter know whether or not there was a target present by saying Yes or No. The participant's response and the time from when the experimenter gave the prompt to when the participant pressed the button (i.e. made the decision) was recorded. The task was completed once each of the 30 targets had been displayed and 30 'no target' conditions had been presented in a random order.

The procedures for tasks 1 and 2 were then carried out for cars 2 and 3.

### **5.1.3. Participants**

Twenty current car drivers were invited to participate in the trials. It was ensured that the ratio of male to female participants was approximately 50:50 and the ratio of young to old participants was also 50:50, the age range being between the ages of 21 and 71 years.

## **5.2. Results/findings**

Displayed in Table 11 and Table 12 is the raw data collected from each of the three cars used in the trials. This includes the participants' reaction times to detecting the presence of each target within the road scene and the number of correct target detections.

To determine if differences in A-pillar obscuration angles led to an increased likelihood of targets being obstructed paired two-tailed t-tests and chi-squared tests were carried out.

**Table 11: Number of targets undetected in Tasks 1 and 2\*.**

|            |    | Number of targets undetected ( out of 20) |             |            |            |             |            |
|------------|----|---|-------------|------------|------------|-------------|------------|
|            |    | Task 1                                    |             |            | Task 2     |             |            |
|            |    | Target No.                                | Laguna (A1) | Sunny (B1) | Focus (C1) | Laguna (A1) | Sunny (B1) |
| NEAR SIDE  | 1  | 3   | 1           | 1          | 2          | 0           | 1          |
|            | 2  | 5   | 0           | 1          | 1          | 0           | 0          |
|            | 3  | 13  | 8           | 13         | 11         | 5           | 7          |
|            | 4  | 12  | 11          | 15         | 8          | 8           | 11         |
|            | 5  | 5   | 9           | 13         | 2          | 5           | 10         |
|            | 6  | 0   | 3           | 1          | 0          | 0           | 0          |
|            | 7  | 1   | 1           | 0          | 0          | 0           | 0          |
|            | 8  | 0   | 1           | 0          | 0          | 0           | 0          |
|            | 9  | 3   | 4           | 5          | 2          | 0           | 2          |
|            | 10 | 2   | 3           | 2          | 0          | 0           | 1          |
|            | 11 | 1   | 3           | 3          | 0          | 1           | 1          |
|            | 12 | 1   | 2           | 2          | 0          | 0           | 1          |
|            | 13 | 0   | 1           | 1          | 1          | 0           | 0          |
|            | 14 | 0   | 0           | 1          | 0          | 0           | 0          |
| OFF SIDE   | 15 | 0   | 0           | 0          | 0          | 0           | 0          |
|            | 16 | 0   | 0           | 0          | 0          | 0           | 1          |
|            | 17 | 0   | 0           | 0          | 0          | 0           | 0          |
|            | 18 | 0   | 0           | 0          | 1          | 0           | 0          |
|            | 19 | 2   | 0           | 1          | 0          | 1           | 0          |
|            | 20 | 3   | 1           | 4          | 3          | 2           | 0          |
|            | 21 | 13  | 9           | 12         | 6          | 3           | 5          |
|            | 22 | 19  | 19          | 17         | 12         | 11          | 11         |
|            | 23 | 11  | 7           | 10         | 2          | 1           | 2          |
|            | 24 | 5   | 4           | 9          | 0          | 1           | 1          |
|            | 25 | 4   | 3           | 6          | 1          | 0           | 0          |
|            | 26 | 4   | 2           | 3          | 0          | 0           | 0          |
|            | 27 | 1   | 1           | 2          | 1          | 0           | 0          |
|            | 28 | 0   | 0           | 0          | 0          | 0           | 0          |
|            | 29 | 0   | 0           | 1          | 1          | 0           | 0          |
|            | 30 | 1   | 1           | 1          | 0          | 0           | 0          |
| <b>Sum</b> |    | <b>109</b>                                | <b>94</b>   | <b>124</b> | <b>54</b>  | <b>38</b>   | <b>54</b>  |

**Table 12: Mean detection times of those targets detected in Tasks 1 and 2.**

|             |    | Mean detection time of the targets detected (seconds) |             |             |             |             |             |
|-------------|----|---|-------------|-------------|-------------|-------------|-------------|
|             |    | Task 1  |             |             | Task 2      |             |             |
|             |    | Target No.  | Laguna (A2) | Sunny (B2)  | Focus (C2)  | Laguna (A2) | Sunny (B2)  |
| NEAR SIDE   | 1  | 0.95  | 0.88        | 0.68        | 1.14        | 0.82        | 0.99        |
|             | 2  | 0.63  | 0.65        | 0.81        | 1.02        | 0.81        | 1.07        |
|             | 3  | 1.37  | 0.79        | 0.77        | 1.60        | 1.49        | 2.37        |
|             | 4  | 1.11  | 0.80        | 1.47        | 1.52        | 1.55        | 2.01        |
|             | 5  | 0.68  | 0.83        | 1.02        | 0.97        | 1.32        | 2.12        |
|             | 6  | 0.57  | 0.57        | 0.65        | 0.80        | 0.61        | 0.63        |
|             | 7  | 0.66  | 0.73        | 0.61        | 0.60        | 0.58        | 0.73        |
|             | 8  | 0.61  | 0.71        | 0.59        | 0.78        | 0.68        | 0.63        |
|             | 9  | 0.67  | 1.13        | 0.55        | 0.67        | 0.80        | 1.02        |
|             | 10 | 0.52  | 0.55        | 0.66        | 0.61        | 0.63        | 0.72        |
|             | 11 | 0.63  | 0.97        | 0.72        | 0.66        | 0.81        | 0.81        |
|             | 12 | 0.57  | 0.79        | 0.69        | 0.67        | 0.69        | 0.69        |
|             | 13 | 0.62  | 0.52        | 0.53        | 0.90        | 0.68        | 0.73        |
|             | 14 | 0.68  | 0.69        | 0.64        | 0.66        | 0.71        | 0.66        |
| OFF SIDE    | 15 | 0.54  | 0.53        | 0.56        | 0.67        | 0.58        | 0.63        |
|             | 16 | 0.57  | 0.56        | 0.58        | 0.69        | 0.68        | 0.65        |
|             | 17 | 0.52  | 0.58        | 0.61        | 0.67        | 0.61        | 0.64        |
|             | 18 | 0.60  | 0.65        | 0.68        | 0.81        | 0.65        | 0.70        |
|             | 19 | 0.73  | 0.69        | 0.70        | 0.88        | 0.85        | 0.78        |
|             | 20 | 1.06  | 0.68        | 0.71        | 1.13        | 0.99        | 1.09        |
|             | 21 | 1.40  | 0.67        | 1.89        | 1.50        | 0.85        | 1.34        |
|             | 22 | 0.53  | 3.39        | 0.94        | 2.17        | 2.34        | 2.22        |
|             | 23 | 0.59  | 0.98        | 0.78        | 1.39        | 1.14        | 1.26        |
|             | 24 | 0.95  | 0.94        | 0.66        | 1.14        | 1.21        | 1.22        |
|             | 25 | 0.96  | 0.95        | 0.92        | 0.82        | 0.86        | 0.99        |
|             | 26 | 0.86  | 0.68        | 0.57        | 1.03        | 0.83        | 0.91        |
|             | 27 | 0.92  | 0.94        | 0.92        | 0.93        | 0.87        | 1.02        |
|             | 28 | 0.78  | 0.68        | 0.56        | 0.76        | 0.69        | 0.65        |
|             | 29 | 0.66  | 0.62        | 0.55        | 0.82        | 0.80        | 1.02        |
|             | 30 | 0.67  | 0.60        | 0.55        | 0.88        | 0.71        | 0.91        |
| <b>Mean</b> |    | <b>0.75</b>   | <b>0.82</b> | <b>0.75</b> | <b>0.96</b> | <b>0.89</b> | <b>1.04</b> |

\*see section 5.2.1 for description of the shaded and outlined areas

### 5.2.1. Task 1

*What effect does A-pillar obscuration have when the drivers' focus of attention is on the road ahead?*

Figure 9 shows the main areas in the visual field where target obscuration occurred most frequently. It can be seen that the obscuration areas which are most affected by the A-pillars are:

- Near-side: from 55° to 65° (i.e. a range of 10°) to the left of the driver's line of sight.
- Off-side: from 22° to 40° (i.e. a range of 18°) to the right of the driver's line of sight.

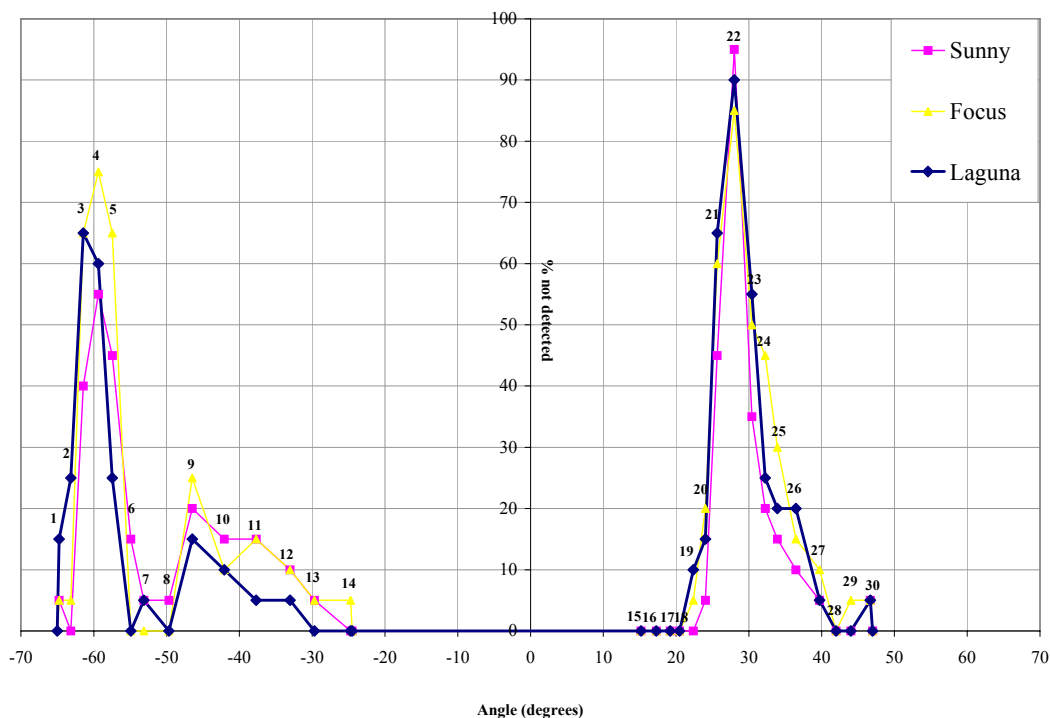

**Figure 9: The distribution of target obscuration within the visual field in task 1, where an angle of 0° refers to the drivers line of sight.**

Figure 9 also shows another area on the near-side where targets were being obscured, between 25° and 46° (i.e. a range of 21°).

It was concluded that this was an effect of the internal rear view mirror on some drivers' ability to see targets within this area, particularly those participants with greater sitting heights. Therefore, in order to obtain the rate of obscuration caused by the A-pillars alone, only the targets which were affected by A-pillar obscuration were included in the

analysis. These were targets 1 to 6 on the near-side and targets 19 to 27 on the off-side (see also areas outlined in Table 11).

Figure 10 shows the location of the near-side and off-side obscuration areas (i.e. where a target was obscured more than once) in each of the three cars, in relation to the thirty targets (see also all shaded areas in Table 11).

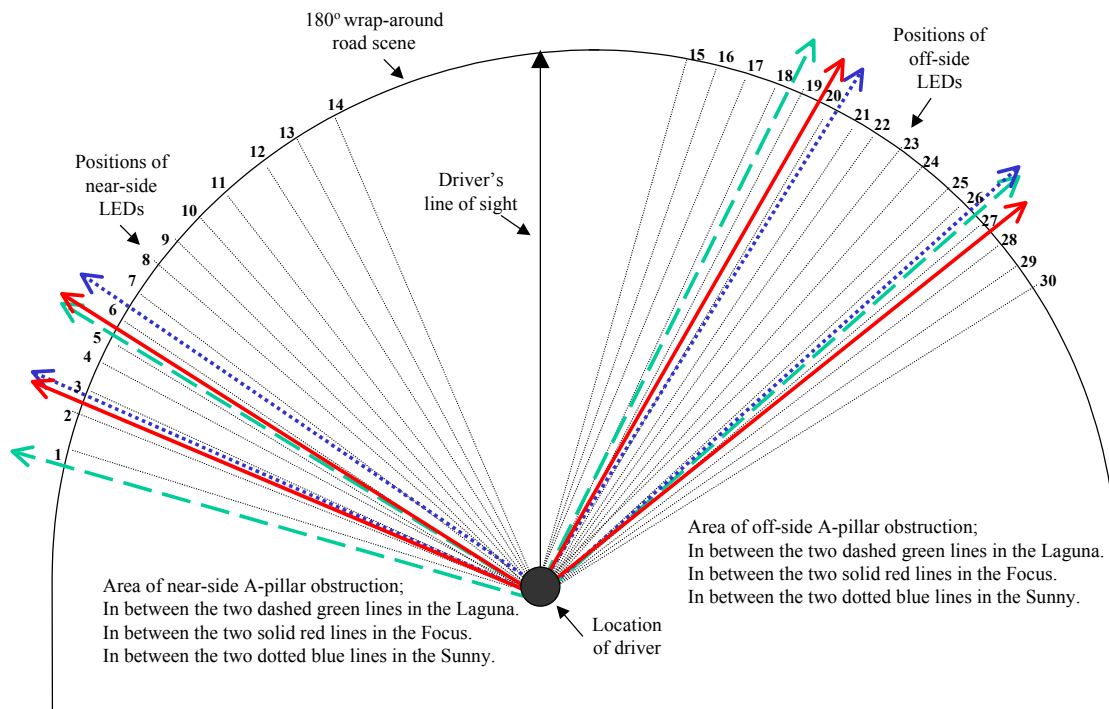

**Figure 10: The location of the obscuration areas in each car in relation to the targets**

A statistical comparison of the obscuration rate for each target revealed a number of areas in the field of view which were significantly more obscured. These are displayed in Table 13 and are defined as being areas which contained targets that were obscured significantly more often than at least one of the other targets in the A-pillar obscuration area, i.e. targets 1 to 6 on the near-side and 19 to 27 on the off-side (see also the dark shaded areas in Table 11).

**Table 13: The areas of significantly high obscuration in the field of view**

|               | Near-side                  | Off-side                     |
|---------------|----------------------------|------------------------------|
| <b>Laguna</b> | 59° – 61° (targets 4 to 3) | 26° – 30° (targets 21 to 23) |
| <b>Focus</b>  | 57° – 61° (targets 5 to 3) | 26° – 32° (targets 21 to 24) |
| <b>Sunny</b>  | 57° – 61° (targets 5 to 3) | 26° – 28° (targets 21 to 22) |

*What was the rate of A-pillar obscuration in each car?*

Table 14 displays the rate of A-pillar obscuration in each car.

**Table 14: The percentage of targets obscured in each car by off and near-side A-pillars**

|               | Near-side | Off-side |
|---------------|-----------|----------|
| <b>Laguna</b> | 32%       | 34%      |
| <b>Focus</b>  | 37%       | 36%      |
| <b>Sunny</b>  | 27%       | 26%      |

*Does an increase in A-pillar thickness lead to increased obscuration and if so, is the increase significant?*

Figure 11 shows how A-pillar thickness correlated with obscuration rate (off-side and near side).

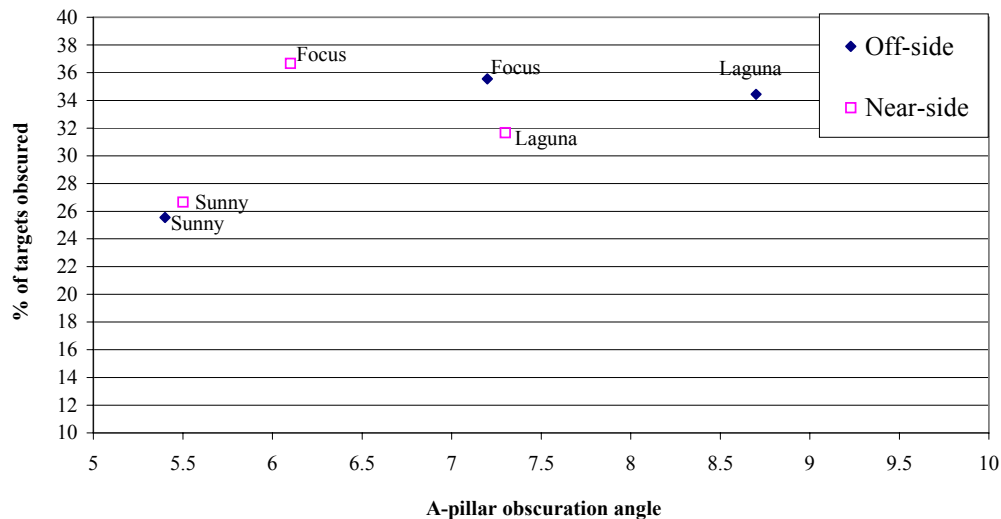

**Figure 11: The correlation of A-pillar obscuration angle with level of target obscuration (as calculated from Table 4 and defined in Figure 2).**

On the off-side, an A-pillar obscuration angle of  $5.4^{\circ}$  (Sunny) resulted in significantly less obscuration than angles of  $7.2^{\circ}$  (Focus) and  $8.7^{\circ}$  (Laguna). No significant difference in rate of obscuration was found between angles of  $7.2^{\circ}$  and  $8.7^{\circ}$ .

On the near-side, an A-pillar obscuration angle of  $5.5^{\circ}$  (Sunny) resulted in less obscuration than angles of  $6.1^{\circ}$  (Focus) and  $7.3^{\circ}$  (Laguna), but this decrease was not statistically significant.

***Do the A-pillars on newer cars lead to greater obscuration than those on older models and if so, is this significant?***

When comparing obscuration rate in older cars compared to new, it was found that the off-side A-pillars in the new cars led to significantly greater obscuration than the off-side A-pillar in the older car. No statistically significant difference was found between new and older cars when comparing near-side obscuration rates.

### 5.2.2. Task 2

***When asked to search for targets, (i.e. look around the A-pillars in Task 2) is the level of obscuration significantly reduced for each car?***

Figure 12 shows the main areas in the visual field where target obscuration occurred most frequently during the search task.

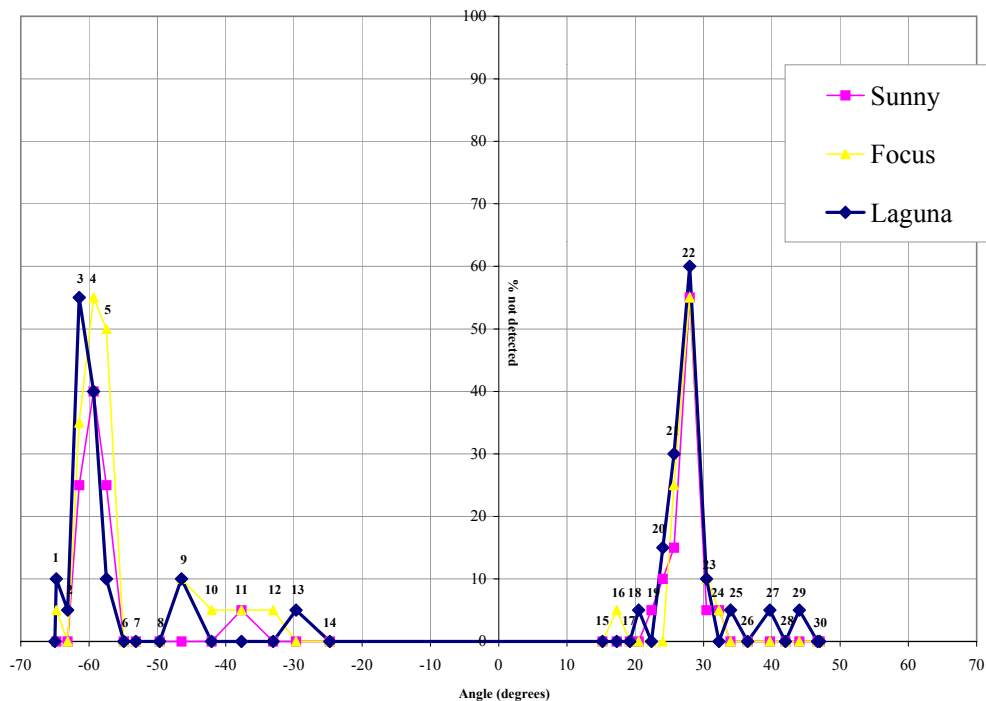

**Figure 12: The distribution of target obscuration within the visual field in task 2, where an angle of 0° is refers to the drivers line of sight.**

On both the off-side and near-side, the number of obscured targets is significantly reduced in all cars when participants carry out the search task (task 2), as opposed to carrying out the detection task (task 1) (see Figure 9).

As with the first task, the least number of targets were obscured by the off-side and near-side A-pillars in the Sunny.

In terms of reaction time, the participants were, on average able to detect the targets quicker on both the off-side and near side in the Sunny. However, this was only significant on the near-side, where the mean target time was significantly quicker for the Sunny than for the Focus.

## **6.0 Discussion and conclusions**

The conclusion to both the literature review and driver survey, that A-pillars impede the forward field of view, was verified by the trials which were conducted by ICE Ergonomics.

In addition to confirming the detriment to forward vision, the trials also enabled the following quantitative evaluations to be made:

### **6.1. Changes in A-pillar design**

Obscuration angles were simulated, but no evidence was found to suggest that vehicles included in the survey exceeded the regulations. The survey confirmed significant differences in A-pillar design between older and newer cars, namely that newer cars had: longer A-pillars; greater internal horizontal obscuration angles (including obscuration band); greater A-pillar and windscreen inclination from vertical and closer A-pillar to eye-point distances.

### **6.2. Extent of obstruction to forward visibility**

Approximately one third of all the targets presented in the vicinity of the A-pillar were not detected. (This varied from 27% to 37% dependent upon the type of car and the near-side/off-side location).

### **6.3. Comparative performance of older and newer vehicles**

Significantly more targets were seen in the vicinity of the off-side A-pillar for the older car (74%) compared to the two newer cars (64% and 66%). The same effect was noted for the near-side A-pillar although this was not statistically significant. These results would therefore imply that older vehicle designs are less likely to be involved in accidents where A-pillar obscuration is a contributory factor.



#### **6.4. Compensation of A-pillar obscuration by driver behaviour**

The likelihood of seeing a target in the vicinity of both the near-side and off-side A-pillars was significantly improved when drivers made the effort to look around them. (This can be seen by a comparison of Figure 9 and Figure 12). However it is inadvisable to rely on this behaviour to compensate for poor forward visibility since:

- Even if driver training schemes were established to educate and encourage such behaviour it cannot be assumed that all drivers will comply in this way all the time,
- It may also be the case that such behaviour may result in more accidents on the road. Whilst it is appropriate to engage in actively searching for potential hazards (targets) in the vicinity of the A-pillar at junctions, it would not be prudent to do this to the same extent when travelling along a road since the driver also needs to give attention to scene ahead. Since drivers are therefore less able to spend time compensating for the A-pillar whilst driving, hazard detection in the drivers peripheral vision is likely to be improved by a reduction in the obscuration imposed by A-pillars.

## **7.0 Recommendations**

### **7.1. A-pillar design**

The results of comparing the off-side field of vision between older and newer cars indicate that there are advantages, in terms of improved detection rates, to using A-pillars which impose smaller angles of obscuration. It is therefore recommended that obscuration angles are kept to a minimum.

### **7.2. Future work**

In the absence of accident data which can be reliably related to A-pillar obscuration as a causal factor, the monetary costs of injuries incurred cannot be related to changes in A-pillar design. Without such quantification it is difficult to specify what level of A-pillar obscuration, and resultant risk to road safety, is acceptable. Consideration should therefore be given to recording A-pillar geometry when carrying out On-the-Spot accident studies and STATS19 data.

However further work should aim to quantify the relationship between A-pillar geometry and object detection. One possible step towards this would be to plot for each angle of obscuration between 0° and 6°, the corresponding likelihood of non-detection of a target in the A-pillar vicinity. The information, which would be obtained from such a study concerning the relative increases in non-detection with increasing obscuration angle, may provide some indication as to an acceptable limit.

In addition, such a study could include analysis, not just of the degree of obscuration, but where that obscuration occurs in the visual field i.e. where is it best to locate A-pillars in the drivers' visual field. Information from accident data would be beneficial in this respect.

It may also be of value to advise drivers, particularly those who are updating their vehicles to newer version of the model they currently drive, that their vision particularly to the off-side may be affected. It may also be useful to make manufacturers aware of the vision implications of increased A-pillar thickness.



## 8.0 References

**ALLEN, M. J., ABRAMS, B. S., GINSBURG, A. P. AND WEINTRAUB, L., 1996.** *Forensic aspects of vision and highway safety.* Lawyers & Judges Publishing Co, Inc.

**BHISE, V. D.,** Visual search by drivers in freeway merging: implications for vehicle design. pp. 152-173.

**COUNCIL DIRECTIVE 77/649/EEC, 1977.** *Council directive on the approximation of the laws of the Member States relating to the field of vision of motor vehicle drivers.* Official Journal of the European Communities, No. L 267/1.

**CHONG, J., AND TRIGGS, T. J., 1989.** Visual Accommodation and target detection in the vicinity of a window post. *Human Factors*, **31(1)**. The Human Factors Society, pp. 63 – 75.

**FOSBERRY, R. A. C., AND MILLS, B. C., 1956.** *Measurements of the driver's visibility from private cars and commercial vehicles and some recommendations for minimum visibility requirements.* MIRA.

**FOWKES, M., 1986.** The legislative determination of the drivers field of view. *Vision in Vehicles.* Elsevier Science Limited, pp. 305-312.

**HASLEGRAVE, C. M., 1993.** Visual aspects in vehicle design. In: *Automotive Ergonomics* (Peacock, B. and Kaewowski, W). Taylor and Francis, pp. 79-98.

**PORTER, J. M., & STEARN, M. C., 1986.** A technique for the comparative assessment of external visibility characteristics in road vehicles. *Vision in Vehicles.* Elsevier Science Limited, pp. 313-322.

## **Appendix 1: Directives, Regulations and Standards (A-pillar obscuration)**

The following section is a précis of the legislative literature pertaining to A-pillar obscuration. It pays particular reference to the visual properties required and the processes of approval testing.

### **1.1 Council Directive 77/649/EEC (as amended by 81/643/EEC, 88/366/EEC and 90/630/EEC)**

#### **1.1.1 Scope**

‘ . . . applies to the 180° forward field of vision of the drivers of vehicles in category M<sub>1</sub>’.  
Category M<sub>1</sub> is defined as “Motor Vehicles with at least four wheels used for the carriage of passengers and comprising no more than eight seats in addition to the drivers seat”.

**1.1.2 General specification**

No vehicle shall have more than two A-pillars.

The angle of binocular obstruction of each A-pillar shall not exceed 6° (Figure 1).

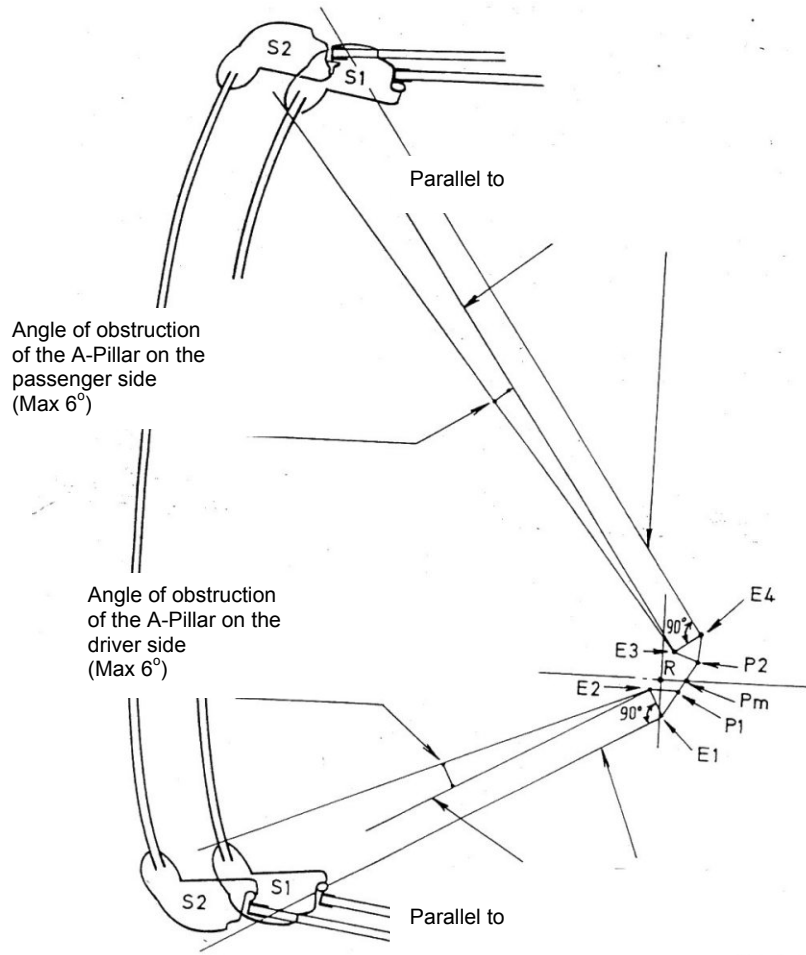

**Figure 1: Pillar obstruction**

There shall be no obstructions, other than those created by A-pillars and/or vent window division bars, rear-view mirrors and windscreen wipers, in the driver’s 180° forward direct field of vision below a horizontal plane through  $V_1$  and above three planes through  $V_2$ , one being perpendicular to the plane X-Z and declining forward 4° below the horizontal and the other two being perpendicular to the plane Y-Z and declining 4° below the horizontal. (Figure 2).

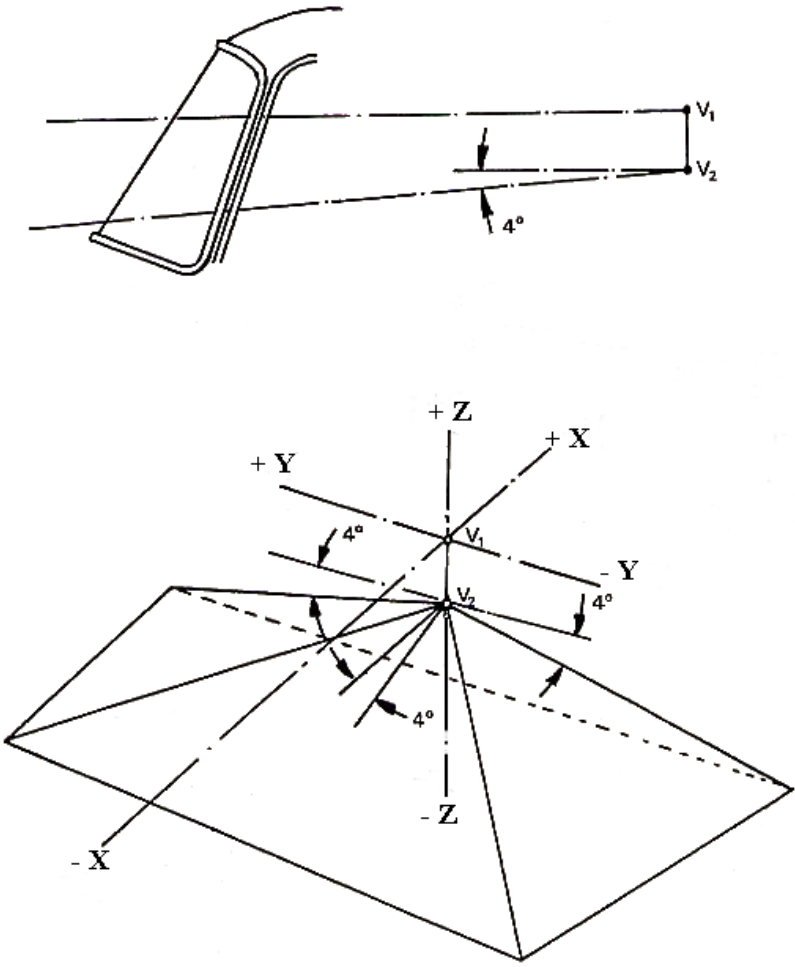

**Figure 2: Evaluation of obstructions in the 180° forward direct field of vision of the driver**

### 1.1.3 Definitions

A-pillar:- means any roof support forward of the vertical transverse plane located 68mm in front of the V points and includes non-transparent items, such as windscreen mouldings and door frames, attached or contiguous to such a support.

Primary reference marks:- are defined as ‘holes, surfaces, marks and identification signs on the vehicle body which may be the control points used for body-assembly purposes.’

R-point (seating reference point):- defined by the vehicle manufacturer relative to primary reference marks and:

- has co-ordinates determined in relation to the vehicle structure;
- is the theoretical position of the point of torso/thighs rotation (H-point) for the lowest most rearward normal driving position.

H-point:- is the intersection, in a longitudinal vertical plane, of the theoretical axis of rotation between the thighs and torso of a human body which indicates the position of a seated occupant in the passenger compartment.

Three-dimensional reference grid:- is a reference system which consists of a:

- Vertical longitudinal plane X-Z      (+ve X to rear; -ve X to front)
- Horizontal plane X-Y              (+ve Y to right; -ve Y to left)
- Vertical transverse plane Y-Z      (+ve Z up; -ve Z down)

P-points:- are points about which the driver’s head rotates when he views objects on a horizontal plane at eye level. Two P-points,  $P_1$  and  $P_2$ , are defined which account for some relative movement of the torso as the head is rotated.

$P_1$  and  $P_2$  are positioned relative to the R-point using the three-dimensional grid references. The  $P_m$  point is the point of intersection between the straight line  $P_1$  and  $P_2$ , and the longitudinal vertical plane passing through the R point.



**Table 1: Drivers head rotation point (P) relative to vehicle’s ‘R’ point**

| <b>P-point</b> | <b>X</b> | <b>Y</b> | <b>Z</b> |
|----------------|----------|----------|----------|
| P <sub>1</sub> | +35mm    | -20mm    | +627mm   |
| P <sub>2</sub> | +63mm    | + 47mm   | +627mm   |
| P <sub>m</sub> | +43.36mm | 0mm      | +627mm   |

E-points:- correspond to the driver’s eye position, e.g. E<sub>1</sub> and E<sub>2</sub> are 65mm apart and are 104 mm from P<sub>1</sub> (see figure 3).

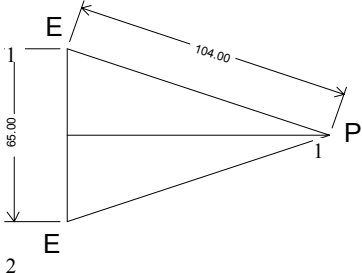

**Figure 3: Distance of eye points (E1 & E2) relative to head rotation point (P)**

V points are points whose position in the passenger compartment is determined as a function of vertical longitudinal planes passing through the centres of the outermost designated seating positions on the front seat and in relation to the R point.

## Appendix 2: Car Driver's Questionnaire

### 2.1. Introduction:

Hello, I am from Loughborough University and we are undertaking research into drivers' visibility from cars. Can you spare a few moments while we ask you some brief questions about your car?

This is non-judgemental: there are no right or wrong answers we simply want your real opinions and experiences. All information is confidential. We will not reveal the answers in any way in which you will be identifiable.

### 2.2. What make and model of car do you normally drive?

Make: \_\_\_\_\_ Model: \_\_\_\_\_

Year or Reg letter: \_\_\_\_\_ How long owned \_\_\_\_\_ yrs

Approximate annual mileage \_\_\_\_\_ miles

#### 2.2.1. Have you ever had a new windscreen fitted?

Yes      how long ago \_\_\_\_\_ yrs

No

#### 2.2.2. Does mist on the inside of your windscreen ever reduce your vision outside the car?

Often                      sometimes                      rarely                      never (*go to 2.3*)

#### 2.2.3. Under what circumstances?

|          |
|----------|
| Comments |
|----------|

**2.2.4. How do you clear it?**

Fan/heater      cloth      hand      Other (specify)

**2.2.5. Do you ever have to clear it while driving?**

Often      sometimes      rarely      never

Comments

**2.3. When did you last clean the inside of your windscreen of accumulated dirt?**

Within the last week

Within the last month

Within the last three months

More than three months ago

Comments

**2.4. Do you clean the inside of your windows routinely or just when you notice they are dirty?**

Routinely      When dirty

**2.5. Have you ever experienced problems with vision because of accumulated dirt on the inside of your windows (e.g. due to dazzle from headlights at night)?**

Often                      sometimes                      rarely                      never

Comments e.g. vision problems experienced

**2.6. Do you ever experience problems driving in bright sunlight?**

Often                      sometimes                      rarely                      never (*go to 2.8*)

Comments e.g. vision problems experienced

**2.6.1 If yes, what do you do about it?**

Comments

**2.7. Have you had any accidents or near misses because of glare or dazzle from bright sunlight?**

Yes

No

Specify/comments

**2.8. Are any of the windows in your car tinted?**

Yes *specify ( which windows, degree & colour of tint if known)*

No *(go to 2.8.4)*

Comments

**2.8.1. If yes, were they tinted when you acquired the car?**

Yes

No *(go to 2.8.3)*

**2.8.2. Did it influence your purchase decision?**

Yes (positively? – explain below)

No

|          |
|----------|
| Comments |
|----------|

*Now go to 2.9*

**2.8.3. Why did you have the windows tinted?**

|          |
|----------|
| Comments |
|----------|

*Now go to 1.9*

**2.8.4. Ignoring the cost, would you consider having tinted windows in your car?**

Yes Which windows?

No

|               |
|---------------|
| Why?/comments |
|---------------|

- 2.9. Thinking now about the pillars at the side of the windscreen in your car (A-pillars). Would you say that they ever restrict your vision out of the car?**

Often                      sometimes                      rarely                      never

Specify/comments (PROBE frequency and circumstances)

- 2.9.1. Are you aware of ever having to move your head to be able to see around the pillar?**

Often                      sometimes                      rarely                      never

Specify/comments (PROBE frequency and circumstances)

- 2.10. How does this pillar compare to other cars you have driven in terms of its effects on visibility?**

Same                      Better                      Worse

Specify/comments

**2.11. Have you had any accidents or near misses because of objects being obscured by this pillar?**

Yes

No

|                  |
|------------------|
| Specify/comments |
|------------------|

**2.12. Respondent details**

Year of Birth: \_\_\_/\_\_\_/99

Sex: M / F

Years driving: \_\_\_\_\_yrs

Interview conducted by \_\_\_\_\_ Date \_\_\_/\_\_\_/



### **Appendix 3: Driver vision questionnaire data (relevant to A-pillar obscuration)**

#### **Interview sample:**

Total sample size = 30 , (14 male, 16 female)

#### **3.1 Age of current vehicle**

| <b>Years</b> | <b>Age of car</b> | <b>How long owned</b> |
|--------------|-------------------|-----------------------|
| Average      | 7                 | 2.9                   |
| Minimum      | 2                 | 0.1                   |
| Maximum      | 15                | 13.0                  |

#### **3.2 Age of driver and years of driving**

| <b>Years</b> | <b>Age</b> | <b>Years driving</b> |
|--------------|------------|----------------------|
| Average      | 42         | 23                   |
| Minimum      | 21         | 4                    |
| Maximum      | 72         | 54                   |

**3.3 Thinking now about the pillars at the side of the windscreen in your car (A-pillars). Would you say that they ever restrict your vision out of the car?**

|             |    |
|-------------|----|
| never       | 13 |
| rarely      | 5  |
| sometimes   | 7  |
| often       | 4  |
| no response | 1  |

Comments:

|  |
|--|
| - Turning 90 degrees onto other road   |
| - Roundabouts  |
| - Punto always restricted vision - Ford Escort at roundabouts cause problems   |
| - Tight T junctions, when leaning forward to see   |
| - Turning right at T junctions, leaning forward, small angle to see left between tax stickers, pillar and rear-view mirror |
| - Quite narrow   |
| - Turning onto major road  |
| - Are very thin on this car  |
| - Turning right  |
| - Back ones more of a problem  |
| - 90 degree turns, pulling out onto dual carriageways off slip roads   |
| - Two cars approaching junction - one obscured, and roundabouts  |
| - Looking right for 90 degree junction   |
| - Reversing into spaces - difficult judge where sides are  |
| - Roundabouts or corners   |
| - Twisty bends   |

**3.4 Are you aware of ever having to move your head to be able to see around the pillar?**

|             |    |
|-------------|----|
| never       | 11 |
| rarely      | 4  |
| sometimes   | 10 |
| often       | 4  |
| no response | 1  |

Comments:

|  |
|--|
| - Roundabouts & reversing                          |
| - When peering round 90 degree turns               |
| - Roundabouts                                      |
| - Sit back and look through side window instead    |
| - A little bit, when turning                       |
| - Will do at some point                            |
| - Might do but unaware                             |
| - As previous plus when parking                    |
| - Have learnt to do it . Saab was worst car for it |
| - Parking  |
| - Twisty bends                                     |
| - Sign posts when stationery                       |

**3.5 How does this pillar compare to other cars you have driven in terms of its effects on visibility?**

|             |    |
|-------------|----|
| same        | 10 |
| better      | 8  |
| worse       | 5  |
| no response | 7  |

Comments:

|  |
|--|
| - Better than older Polo   |
| - Worse than mini, better than Punto                                 |
| - Similar  |
| - Later versions of same car were improved. Other Volvos also better |
| - Narrower than newer cars driven                                    |
| - Better than older cars   |
| - Never really noticed   |
| - Better than Ford Mondeo  |
| - Worse than small cars - Nova                                       |
| - No difference  |
| - Better than Saab   |
| - Better than Nissan Micra   |
| - Never really been a problem  |
| - Mazda about average. Saab was worse                                |
| - Worse than Toyota Starlet  |
| - Is wider than Escort   |
| - Same as other Rovers, better than some others                      |
| - Only ever had Renault  |

**3.6 Have you had any accidents or near misses because of things being obscured by this pillar?**

|             |    |
|-------------|----|
| Yes         | 2  |
| No          | 27 |
| No response | 1  |

Comments:

|   |
|---|
| - Approaching T junction 3 or 4 near misses over the years (various cars) |
| - Near miss, roundabouts, didn't see car                                  |

## **Appendix 4: Survey of windscreen swept area**

### **4.1 Introduction**

The project entitled ‘Quality and field of vision’ (PPAD 9/33/39) undertaken for DTLR (formerly the DETR) required that the effect of A-pillar thickness on driver vision be investigated. In order that a range of vehicles representing the different levels of A-pillar thickness could be used in the experimental work, a survey of vehicles was first undertaken.

Whilst the focus of the survey was to measure A-pillar thickness and the driver’s seated position in order to calculate the visual angle obscured, a request was made by the client for further information to be collected at the same time. The additional information collected related to the area of the windscreen swept by the window wipers. This report details the information obtained from this aspect of the survey.

### **4.2 Survey details**

#### **4.2.1 Vehicles surveyed**

A total of twenty seven vehicles were surveyed and these are detailed in table 1. The cars were selected for inclusion in the survey according to their popularity on the road. This was estimated from sources such as the NCAP testing programme and surveys undertaken by What Car?

#### **4.2.2 Measurements taken**

In addition to the features shown in figure 1 below, values for the windscreen inclination from vertical and the height of the upper and lower edges of the windscreen above the ground, were also collected. These are all given in table 1.

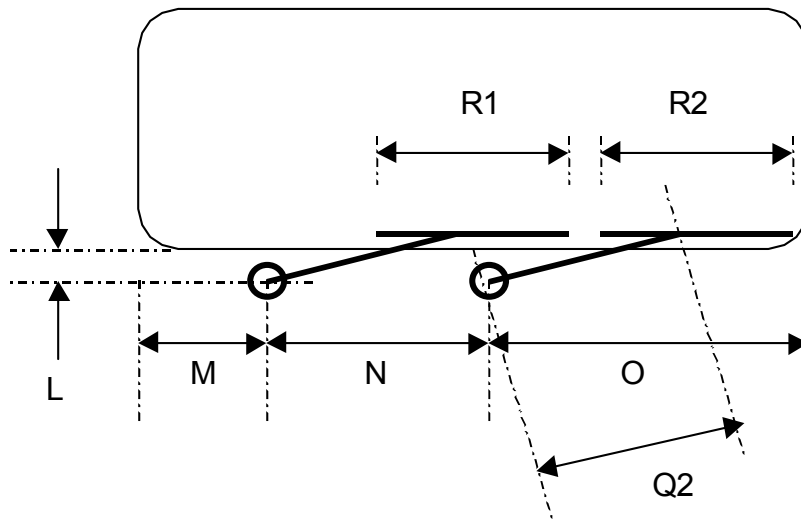

**Figure 1: Features surveyed to calculate swept area of windscreen**

**4.3 Survey results**

The raw data from the survey is given in table 2 overleaf. A statistical summary for each feature measured, in terms of minimum, mean and maximum values, is given in table 1.

**Table 1: Minimum, mean and maximum values for each feature.**

| Feature  | Minimum | Mean | Maximum |
|--|---------|------|---------|
| Depth below windscreen lower edge of wiper drive shaft <b>L</b>              | 50      | 83   | 165     |
| Distance from windscreen's off side edge to first wiper drive shaft <b>M</b> | 22      | 173  | 845     |
| Distance between wiper drive shafts <b>N</b>                                 | 400     | 558  | 1250    |
| Distance of second wiper drive shaft from windscreen's near side <b>O</b>    | 130     | 746  | 1030    |
| Length of off side wiper arm <b>Q1</b>                                       | 425     | 544  | 840     |
| Length of near side wiper arm <b>Q2</b>                                      | 455     | 598  | 895     |
| Length of off side wiper blade <b>R1</b>                                     | 460     | 549  | 705     |
| Length of near side wiper blade <b>R2</b>                                    | 355     | 511  | 705     |
| Windscreen inclination from vertical   | 27      | 31   | 49      |
| Height of windscreen top edge (centre) above ground                          | 1214    | 1375 | 1652    |
| Height of windscreen bottom edge (centre) above ground                       | 615     | 955  | 1210    |

**Table 2: Windscreen swept area – raw data from survey**

| Car Number  | 1    | 2           | 3    | 4             | 5      | 6          | 7      | 8    | 9           | 10      |
|---|------|-------------|------|---------------|--------|------------|--------|------|-------------|---------|
| Make  | Audi | Alpha Romeo | Audi | Jeep          | Honda  | Land Rover | Jaguar | BMW  | Fiat        | Peugeot |
| Model   | A4   | 156         | A6   | rand Cherokee | Accord | Discovery  | XK8    | 728i | Seicento SX | 406     |
| Year/ Registration  | T    | T           | T    | T             | V      | S          | T      | T    | T           | T       |
| Depth below windscreen lower edge of wiper drive shaft L              | 55   | 60          | 75   | 120           | 65     | 105        | 126    | 165  | 50          | 50      |
| Distance from windscreen's off side edge to first wiper drive shaft M | 113  | 135         | 90   | 140           | 85     | 240        | 60     | 845  | 115         | 125     |
| Distance between wiper drive shafts N                                 | 555  | 510         | 560  | 670           | 496    | 655        | 660    | 570  | 500         | 545     |
| Distance of second wiper drive shaft from windscreen's near side O    | 820  | 860         | 855  | 820           | 880    | 680        | 830    | 220  | 890         | 890     |
| Length of off side wiper arm Q1                                       | 518  | 500         | 560  | 490           | 548    | 460        | 485    | 600  | 425         | 510     |
| Length of near side wiper arm Q2                                      | 558  | 560         | 580  | 510           | 623    | 465        | 530    | 580  | 455         | 600     |
| Length of off side wiper blade R1                                     | 550  | 530         | 570  | 525           | 560    | 520        | 530    | 635  | 480         | 610     |
| Length of near side wiper blade R2                                    | 528  | 535         | 540  | 525           | 481    | 520        | 530    | 560  | 482         | 551     |
| Windscreen inclination from vertical                                  | 27   | 28          | 29   | 33            | 29     | 49         | 27     | 31   | 34          | 29      |
| Height of windscreen top edge (centre) above ground                   | 1324 | 1335        | 1331 | 1602          | 1320   | 1652       | 1214   | 1347 | 1328        | 1344    |
| Height of windscreen bottom edge (centre) above ground                | 615  | 930         | 935  | 1200          | 910    | 1210       | 900    | 890  | 948         | 968     |

| Car Number  | 11      | 12      | 13      | 14     | 15   | 16      | 17      | 18       | 19       | 20     |
|---|---------|---------|---------|--------|------|---------|---------|----------|----------|--------|
| Make  | Renault | Nissan  | Renault | Toyota | Ford | Skoda   | Peugeot | Vauxhall | Seat     | Daewoo |
| Model   | Laguna  | Primera | Espace  | Yaris  | Ka   | Octavia | 206     | Astra    | Alhambra | Matiz  |
| Year/ Registration  | V       | T       | T       | T      | V    | V       | V       | S        | V        | V      |
| Depth below windscreen lower edge of wiper drive shaft L              | 75      | 100     | 75      | 70     | 75   | 75      | 65      | 82       | 115      | 75     |
| Distance from windscreen's off side edge to first wiper drive shaft M | 22      | 70      | 110     | 100    | 90   | 80      | 685     | 100      | 108      | 100    |
| Distance between wiper drive shafts N                                 | 520     | 600     | 440     | 400    | 470  | 500     | 435     | 502      | 1250     | 402    |
| Distance of second wiper drive shaft from windscreen's near side O    | 890     | 762     | 1030    | 890    | 750  | 905     | 180     | 808      | 222      | 810    |
| Length of off side wiper arm Q1                                       | 610     | 521     | 605     | 560    | 470  | 498     | 650     | 560      | 840      | 485    |
| Length of near side wiper arm Q2                                      | 855     | 510     | 820     | 652    | 510  | 682     | 590     | 586      | 565      | 600    |
| Length of off side wiper blade R1                                     | 610     | 530     | 652     | 530    | 480  | 530     | 480     | 506      | 705      | 525    |
| Length of near side wiper blade R2                                    | 455     | 503     | 450     | 355    | 425  | 481     | 660     | 478      | 705      | 400    |
| Windscreen inclination from vertical                                  | 28      | 30      | 30      | 31     | 31   | 31      | 28      | 28       | 30       | 31     |
| Height of windscreen top edge (centre) above ground                   | 1340    | 1308    | 1560    | 1412   | 1323 | 1363    | 1331    | 1325     | 1592     | 1405   |
| Height of windscreen bottom edge (centre) above ground                | 935     | 930     | 1090    | 985    | 964  | 945     | 925     | 945      | 1088     | 968    |

| Car Number  | 21      | 22     | 23   | 24    | 25    | 26     | 27    |
|---|---------|--------|------|-------|-------|--------|-------|
| Make  | Citroen | VW     | BMW  | Rover | Volvo | Ford   | Ford  |
| Model   | Xsara   | Passat | 523i | 200   | V40   | Mondeo | Focus |
| Year/ Registration  | T       | T      | T    | S     | S     | P      | T     |
| Depth below windscreen lower edge of wiper drive shaft L              | 50      | 70     | 80   | 95    | 85    | 75     | 110   |
| Distance from windscreen's off side edge to first wiper drive shaft M | 110     | 65     | 610  | 125   | 100   | 130    | 130   |
| Distance between wiper drive shafts N                                 | 510     | 560    | 650  | 600   | 540   | 480    | 475   |
| Distance of second wiper drive shaft from windscreen's near side O    | 800     | 810    | 130  | 804   | 810   | 905    | 890   |
| Length of off side wiper arm Q1                                       | 480     | 510    | 580  | 550   | 540   | 560    | 570   |
| Length of near side wiper arm Q2                                      | 550     | 500    | 620  | 530   | 560   | 670    | 895   |
| Length of off side wiper blade R1                                     | 555     | 530    | 570  | 460   | 550   | 540    | 550   |
| Length of near side wiper blade R2                                    | 502     | 530    | 660  | 460   | 500   | 500    | 475   |
| Windscreen inclination from vertical                                  | 31      | 30     | 31   | 32    | 29    | 30     | 30    |
| Height of windscreen top edge (centre) above ground                   | 1328    | 1350   | 1372 | 1330  | 1295  | 1320   | 1385  |
| Height of windscreen bottom edge (centre) above ground                | 939     | 970    | 945  | 915   | 953   | 816    | 965   |

