



This item was submitted to Loughborough's Institutional Repository (<https://dspace.lboro.ac.uk/>) by the author and is made available under the following Creative Commons Licence conditions.

 **creative commons**  
C O M M O N S D E E D

**Attribution-NonCommercial-NoDerivs 2.5**

**You are free:**

- to copy, distribute, display, and perform the work

**Under the following conditions:**

 **Attribution.** You must attribute the work in the manner specified by the author or licensor.

 **Noncommercial.** You may not use this work for commercial purposes.

 **No Derivative Works.** You may not alter, transform, or build upon this work.

- For any reuse or distribution, you must make clear to others the license terms of this work.
- Any of these conditions can be waived if you get permission from the copyright holder.

**Your fair use and other rights are in no way affected by the above.**

This is a human-readable summary of the [Legal Code \(the full license\)](#).

[Disclaimer](#) 

For the full text of this licence, please go to:  
<http://creativecommons.org/licenses/by-nc-nd/2.5/>

# Measurement of contact time in short duration sports ball impacts: an experimental method and correlation with the perceptions of elite golfers

J. R. Roberts, R. Jones and S. J. Rothberg

Wolfson School of Mechanical and Manufacturing Engineering, Loughborough University, Loughborough, Leicestershire, LE11 3TU, UK

---

**ABSTRACT:** The perception of 'feel' during a ball-implement impact is considered a significant determinant in equipment selection. Previous studies in golf have found that the perceived time for which the ball and clubface are in contact is a factor in the 'feel' of the shot. This factor appears to have become more significant with the development of the latest metal 'woods'. The purpose of this study was to investigate whether golfers' perceptions of impact duration correspond to measured values or whether the perceptions are created by other factors. A technique has been developed to measure the duration of impact by creating an electrical circuit in which the ball and clubface form a 'switch', completing the circuit whilst contact is maintained between the two bodies. Measurements were taken of the duration of impact between five different types of clubhead and two different constructions of golf ball. Further tests, also reported in this paper, investigated the effect of both clubhead speed at impact and ball compression on the impact duration. The results suggest that the ball has a greater effect on impact duration than the type of clubhead with lower compression balls producing longer impact durations than higher compression balls and two piece balls producing shorter impact durations than three piece, wound balls. It was also found that the duration of impact decreased as the clubhead speed at impact was increased. Finally, results suggest that there is no correlation between the perception of the golfer and the actual duration of impact and therefore other factors are responsible for creating this perception.

---

## Introduction

A previous study of human perceptions of sports equipment focused on the use of drivers in golf (Roberts et al., 2001). The investigation involved interviewing elite golfers during hitting tests on a driving range about their perceptions of shots played with different combinations of clubs and balls. Analysis of their responses grouped together quotes with common themes, identifying individual characteristics of the 'feel' of golf equipment. As part of a larger investigation of the properties of golf equipment that contribute to 'feel', this study concentrates on a characteristic frequently discussed by the golfers interviewed: their perception of the duration of impact.

"...my perception of it is that, because it's a softer textured club, that when the ball makes contact...the harder the face the quicker the ball releases off the club face where[as] the softer [the longer], it stays on."

"I think the ball probably stays on the club head a bit longer with a traditional wood so you feel that you can shape it a wee bit more..."

"It might just be the sound of the club on the ball but it feels as if it's just on there a bit longer..."

"The ball comes off an awful lot quicker and it feels an awful lot more powerful, whereas [with] the wooden headed club it seemed to absorb the ball and it came off with hardly any power on it at all. Whereas this [titanium] club feels as though it comes off an awful lot quicker."

Generally, golfers perceive that the ball is 'absorbed' by traditional wooden clubs increasing the contact time between ball and clubface and decreasing the speed at which the ball leaves the clubface. With modern titanium clubs, they believe the face to be 'harder' and perceive the ball to come off the clubface quickly with increased velocity and a reduced contact time. This 'feel' from impact has a direct influence on the perceived quality of the shot played and is used as an indicator of club performance.

However, since the duration of a golf impact has been estimated in previous studies to be approximately 0.5 ms (Cochran and Stobbs, 1968; Gobush, 1990; Scheie, 1990; Ujihashi, 1994; Hocknell, 1998), it is debatable whether a human can accurately determine small variations in such short periods of time.

The purpose of this study, therefore, was to investigate whether golfers' perceptions of impact duration correlate with the measured values for a range of conditions

including different clubhead types, ball constructions, ball compressions and clubhead speeds. Should golfers be unable to determine differences in impact duration then other factors such as club vibration, impact sound or ball flight may be influencing their perceptions. If the mechanism for generating these perceptions can be understood then it may be possible to design this 'feel' into a golf club. Correlation of ball velocity with golfers' perceptions will be the subject of a further study.

### Techniques for Measurement of Impact Duration

The following section reviews the use of three different techniques, force plates, high-speed imaging and electrical circuits, to measure contact durations of several sports ball impacts. A summary of the findings and a comparison of the techniques are found in Table 1.

#### *Force Plates*

The projection of a ball onto a force plate is a popular method that has been used in a number of sports to investigate characteristics of ball impacts. The force profiles obtained during the collision can be of relevance particularly when studying injury potential. In a study by Cross (1999), balls from tennis, golf and baseball were dropped onto a ceramic piezo disk. With an initial velocity of  $2.95 \text{ ms}^{-1}$ , the impact duration of the tennis ball was 5.75 ms, the initial velocity of the baseball was  $1.25 \text{ ms}^{-1}$  and the impact duration was 2.20 ms while the golf ball initial velocity was  $1.47 \text{ ms}^{-1}$  and the duration of impact was 0.94 ms. The ball velocities at impact in this study, however, were considerably slower than those occurring in play. Ball velocities typical of those generated during a shot with a mid-iron were achieved in a study by Gobush (1990) of the forces acting on golf balls during oblique impacts. Two different construction golf balls were fired by an air cannon at  $29 \text{ ms}^{-1}$  onto a three-component force plate, adjustable in angle, to obtain normal and tangential force profiles during impact. Impact durations were measured at 436 and 442  $\mu\text{s}$  for the two piece and wound balls respectively when striking the plate at an angle of  $20^\circ$  ( $70^\circ$  to the axis of ball flight), increasing to 468 and 476  $\mu\text{s}$  respectively when the plate was adjusted to an angle of  $40^\circ$ . In another study of the dynamic characteristics of golf balls, Ujihashi (1994) fired a selection of balls at speeds from approximately 37 to  $48 \text{ ms}^{-1}$  at a circular steel bar, instrumented to function as a load cell. Impact durations were measured at approximately 420  $\mu\text{s}$  for balls of a two-piece construction, up to approximately 480  $\mu\text{s}$  for balls of a three-piece wound construction but it was unclear whether impact duration varied with ball velocity. Hendee et al. (1998) conducted a study to investigate the effect on impact characteristics of different baseball constructions at impact speeds from 13.4 to  $40.2 \text{ ms}^{-1}$  (30 to 90 mph) using a rigidly mounted force plate. The paper estimated the impact duration of a baseball travelling at  $26.8 \text{ ms}^{-1}$  (60 mph) to be approximately 650  $\mu\text{s}$ . Finally, in two related studies, Armstrong et al. (1988) and Levendusky et al. (1988) investigated the effects of

football characteristics on impact dynamics by dropping balls onto a force plate. With impact velocities ranging from  $9.6$  to  $9.84 \text{ ms}^{-1}$ , an increase in inflation pressure was found to decrease impact duration from 12.40 ms at 6 psi to 11.67 ms at 12 psi and the mean impact duration of 12.13 ms with stitched balls was found to be marginally longer than the 11.94 ms with moulded balls (Armstrong et al., 1988). This relationship was also shown to hold true at greater impact velocities of 17 to  $18 \text{ ms}^{-1}$ , with the mean impact duration for the stitched balls now being measured at 10.76 ms compared to 10.24 ms for the moulded balls (Levendusky et al., 1988).

#### *High-Speed Imaging*

Another method of measuring impact duration is to use a high-speed camera. Difficulties can arise when filming more dynamic sports such as tennis or football as, during play, both human and ball are generally in motion so the impact location is unpredictable and camera placement is problematic. In such studies the usual procedure has, therefore, been to have either the ball or surface stationary prior to impact. In the investigation of tennis impacts by Baker and Putnam (1979), a tennis ball practice machine was used to fire tennis balls at approximately  $28 \text{ ms}^{-1}$  at stationary rackets. Impacts were filmed at rates slightly in excess of 2400 frames/second (0.42 ms/frame) and the impact duration was found to be approximately 4 ms. In studies of football by Tsaousidis and Zatsiorsky (1996) and Asai and Akatsuka (1998), the ball was stationary prior to impact. Tsaousidis and Zatsiorsky (1996) used a camera capable of 4000 frames/second (0.25 ms/frame) to measure impact durations of approximately 25 ms when a football was 'toe kicked' with maximum effort. In comparison, Asai and Akatsuka (1998) used a camera capable of 4500 frames/second (0.22 ms/frame) to measure impact durations of 8.2 and 10.5 ms when two free kick situations 25 to 30 m from goal were simulated. Conveniently, in golf, the ball is always stationary prior to impact and therefore there is no need to manipulate play conditions when using high-speed cameras to film an impact. In a study conducted by Scheie (1990), impact durations of approximately 420  $\mu\text{s}$  were measured between a golf ball and a metal wood, swung at  $50.3 \text{ ms}^{-1}$  by a mechanical robot, using a camera configuration capable of filming 19,100 frames/second (52  $\mu\text{s}/\text{frame}$ ).

#### *Electrical Circuits*

A third technique to measure impact duration, that has been used by Cochran and Stobbs (1968) and Hocknell (1998) in golf and Johnson et al. (1973) in football, involves creating an electrical circuit in which the surface and ball act as a 'switch'. During impact, the circuit is complete for a period of time equal to the duration of contact between the two bodies, thus the impact duration can be obtained by measuring the width of the electrical

**Table 1. Comparison of techniques for measuring impact duration**

Measurement technique	Sport	Investigators	Impact duration measured (ms)	Suitability of technique
Force plate	Golf	Gobush (1990) Ujihashi (1994) Cross (1999)	0.4-1.0	Accuracy and measurement resolution excellent Unrealistic testing conditions
	Baseball	Hendee <i>et al.</i> (1998) Cross (1999)	0.6-2.2	
	Tennis	Cross (1999)	5-75	
	Football	Armstrong <i>et al.</i> (1988) Levendusky <i>et al.</i> (1998)	10.2-12.4	
High-speed imaging	Golf	Scheie (1990)	0.4	Measurement resolution insufficient for this study
	Tennis	Baker & Putnam (1979)	4	
	Football	Tsaousidis & Zatsiorsky (1996) Asai & Akatsuka (1998)	8-25	More realistic testing conditions
Electrical Circuit	Golf	Cochran & Stobbs (1968) Hocknell (1998)	0.4-0.6	Accuracy and measurement resolution excellent
	Football	Johnson <i>et al.</i> (1973)	7.5-8.3	More realistic testing conditions

pulse. To enable the circuit to be formed, the two surfaces of the contacting bodies must be conductive. In the study by Johnson *et al.* (1973), both a football and a rigid plate were covered in a layer of copper foil and the impact duration measured between the two varied from 8.3 ms for a ball striking the plate at 2.68 ms<sup>-1</sup> to 7.5 ms for a ball impacting with a velocity of 7.53 ms<sup>-1</sup>. Cochran and Stobbs (1968) reported the impact duration for a putt with the putter head travelling at 12 feet per second to be 600 µs. In the study by Hocknell (1998), a metal 'wood' was used and a 100 µm thick copper strip was pressed into the cover of a ball during manufacture. The subsequent duration of impact for a club swung by a golf robot with a head speed of 35 ms<sup>-1</sup> was measured at 450 µs.

### Selection of Measurement Technique

The summary in Table 1 outlines the reasons for the selection of a measurement technique for this study. The force plate method for measuring impact duration was rejected because the data, although a useful indicator of impact characteristics, is only an accurate measure of impact duration between a ball and a rigid surface. During impacts between ball and implement or ball and human, significant differences in impact dynamics will occur as the impacting surface will not necessarily be flat, rigid or stationary.

The use of high-speed cameras enables measurements to be taken in more representative conditions, but is not without its limitations. The start and end points of contact are difficult to determine and the resolution of the measurement is limited by the frame-rate of the

camera. For example, the camera system used in the study by Scheie (1990) resulted in a measurement resolution 1/8 of the impact duration. A camera capable of 40,000 frames per second was available for this study but the technique was deemed unsuitable because the measurement resolution would still be too coarse to detect differences in impact duration below 25 µs.

Therefore, the electrical circuit technique was adopted for measurement of impact duration in this study because it is suitable for use with a real club and ball and it offers appropriate measurement resolution.

### Development of Golf Impact Duration Measurement Technique

Three methods of covering an area of the ball with a conductive layer were compared; embedding a copper strip during manufacture, as in the study by Hocknell (1998), attaching a 70 µm thick aluminium foil strip with an acrylic pressure sensitive adhesive and painting on a silver conductive coating, as illustrated in Figure 1. A long, lightweight wire was joined to each ball by soldering it to a small patch of metallic tape. The tape, with a conductive adhesive backing, was attached to the surface of the conductive covering away from the impact area, as illustrated in Figure 2.

To compare the three techniques, five balls with a copper strip pressed into them were selected. A driver was placed in a golf robot such that the impact would be located in the centre of the face and the circuit illustrated in Figure 3 connected. The role of the capacitor was to



Figure 1. Three different techniques for applying conductive coating to a golf ball: from left to right, embedded copper strip, aluminium foil and silver conductive paint.



Figure 2. Wire soldered to a small patch of tape, with a conductive adhesive backing, attached to the surface of the conductive covering.

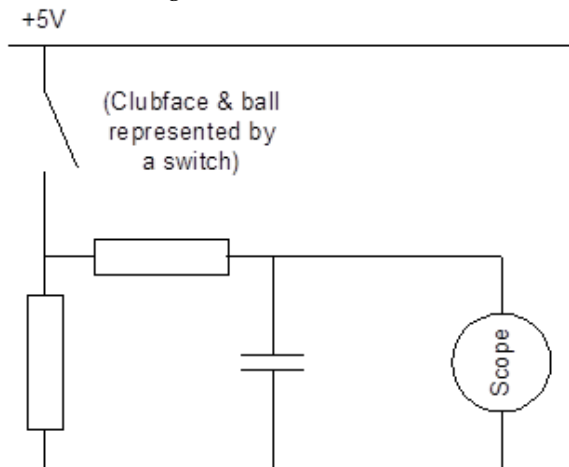

Figure 3. Electrical circuit used to measure impact duration.

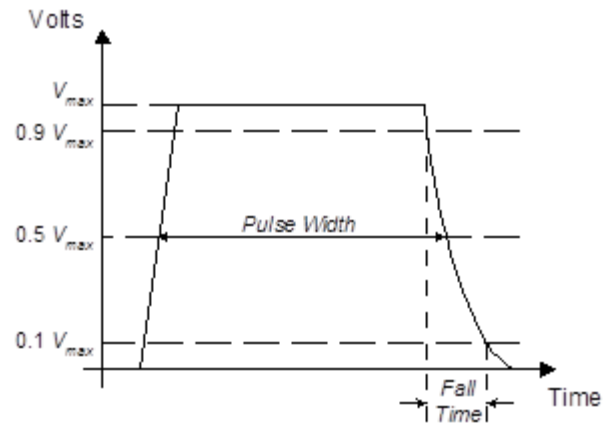

Figure 4. Method for obtaining impact duration (pulse width) and fall time from measured electrical pulses.

filter out high frequency noise from the trace. Three shots were hit with each ball, with a clubhead speed immediately prior to impact of  $44.7 \pm 0.45 \text{ ms}^{-1}$  ( $100 \pm 1 \text{ mph}$ ). The pulse width was measured at 50% of the maximum pulse amplitude and the pulse fall time measured the transition time of the falling edge from 90% to 10% of the maximum amplitude, as illustrated in Figure 4. The results of the fifteen shots were then averaged before the procedure was repeated with the same five balls being prepared using each of the two alternative methods. Example traces from shots using each of the three techniques on the same ball are shown in Figures 5a-c. The means and standard deviations of the pulse widths and fall times from the fifteen shots using each of the three techniques are summarised in Table 2. In addition, the standard deviations of the three shots with each individual ball were averaged for each technique and are also included in the table.

A comparison of the results from the aluminium foil technique with the copper strip method revealed a number of notable points. The aluminium foil method gave a contact duration on average  $10 \mu\text{s}$  longer than the copper impregnated strip technique. The pulse fall time measured using both techniques was approximately  $3 \mu\text{s}$  and is attributable to the discharge of the capacitor. As can be seen from Figures 5a & 5b, both techniques produced a pulse with a sharp, distinct endpoint. For both methods, the standard deviation of the measured contact durations for the fifteen shots with five balls is approximately  $9 \mu\text{s}$ , which is larger than the mean standard deviation for the three shots with each individual ball of approximately  $3 \mu\text{s}$ . This indicates that variability in nominally identical balls has a greater influence on deviations in measured impact duration than inconsistency in the measurement technique. Finally, the measured contact times using the copper impregnated strip became successively longer by on average 2 to  $3 \mu\text{s}$  with each shot with each ball, which may have been due to the strip becoming detached from the ball surface.

There are two possible explanations for the difference of  $10 \mu\text{s}$  in contact duration between the two techniques. Observation of the aluminium strip after each shot

revealed that the foil had been forced into the grooves of the clubface during impact. If the foil then became trapped as the ball released from the clubface, an increase in the measured duration of contact may have resulted. It is also possible that the copper strip was stiff enough to affect the properties of the ball and decrease the contact time.

The application of silver conductive paint was expected to have the least effect on the impact but, in practice, a problem became apparent, as illustrated in Figure 5c. Towards the end of an impact, the pulse produced often had an inconsistent, indistinct endpoint. As a result, the standard deviations of both the pulse widths and the fall times of the measured pulses are large and a number of the contact times measured may have been shorter than in reality, rendering this method inappropriate for this study. This effect may have been a result of the coating losing integrity during the large deformation of the ball that occurs at impact.

The results from this method can still be used to support the other techniques because, having the least influence on the ball's own properties, the method is likely only to underestimate the contact duration. Therefore, it appears that the actual impact time is longer than that measured using the impregnated copper strip and is closer to the time measured using the aluminium foil. A major consideration was that the copper strip would have to be pressed into the ball during manufacture, whereas the aluminium foil could easily be attached to any ball making this the most suitable method for this investigation. The foil also proved useful for attaching to the faces of non-conducting clubheads such as the traditional wooden headed clubs.

**Table 2. Comparison of impact duration results from each ball covering technique**

Method	Pulse width ( $\mu$ s)	Pulse fall time ( $\mu$ s)
Embedded copper strip		
-Average of 15 shots	397.8	2.9
-Standard deviation of 15 shots	8.3	0.2
-Mean standard deviation for each ball	3.6	0.2
Aluminium Foil strip		
-Average of 15 shots	408.0	3.0
-Standard deviation of 15 shots	9.5	0.3
-Mean standard deviation for each ball	2.5	0.2
Silver conductive paint		
-Average of 15 shots	406.3	29.7
-Standard deviation of 15 shots	16.1	17.1
-Mean standard deviation for each ball	16.0	12.5

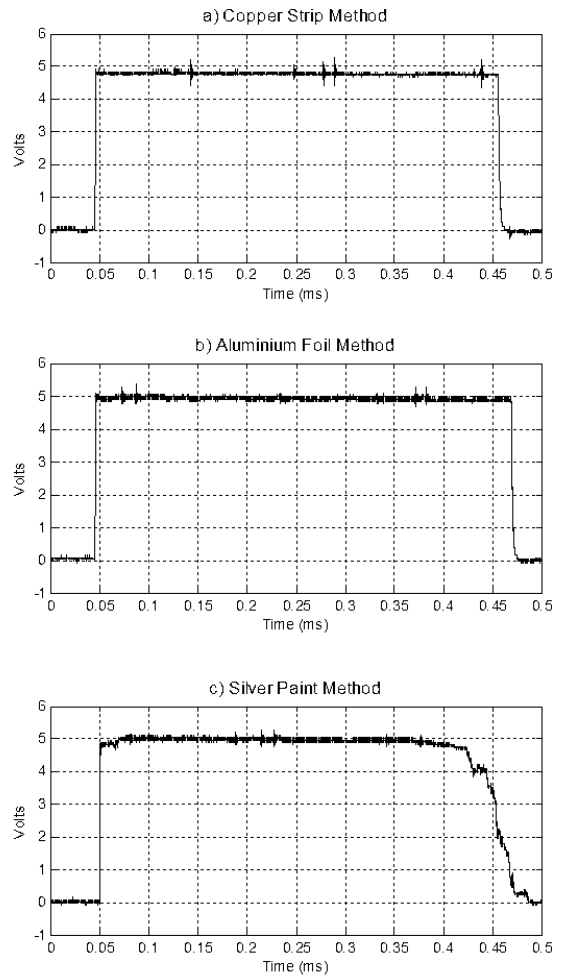

Figure 5. Example impact duration pulses obtained using three different methods of applying a conductive coating to the ball (a) Copper strip method (b) Aluminium foil method (c) Silver paint method.

### Effect of Clubhead Type and Ball Construction on Impact Duration

The first stage of testing was to investigate the effect of clubhead type and ball construction on impact duration. For this test, five different types of clubhead and two different types of ball construction, which had been used in the study by Roberts et al. (2001), were selected.

The clubheads used were:

1. A modern, oversize titanium clubhead 'A'
2. A modern, oversize titanium clubhead 'B'
3. A modern, stainless steel clubhead
4. A traditional, laminated wood clubhead
5. A traditional, persimmon wood clubhead

The balls used were:

- a. A two piece, surlyn covered ball
- b. A three piece, wound, balata covered ball

Each club, in turn, was set up in an electrically powered golf robot such that the impact would be located at the geometric centre of the clubface, with the clubhead travelling at  $44.7 \pm 0.45 \text{ ms}^{-1}$  (100 mph) immediately prior to impact. Five balls of each type were randomly selected and hit five times with each club. The mean mass of the two-piece balls was 45.9 g, standard deviation,  $\sigma = 0.1 \text{ g}$ , and the mean mass of the three-piece balls was 45.5 g,  $\sigma = 0.2 \text{ g}$ .

The results from this test are illustrated in Figure 6. It can be seen that the mean impact duration with the three-piece, wound, balata ball is approximately 16  $\mu\text{s}$  longer than with the two-piece ball, regardless of club type. A P-value of 0.000 was obtained when a two-sample t-test was conducted on the impact durations for each ball type, the ball impact durations can therefore be considered to be significantly different. The overall variation in mean impact duration of 12  $\mu\text{s}$  due to club type is smaller than that due to ball type. A two-sample t-test was performed on each club combination with each ball to determine the significance between the impact durations. For a golfer to be able to determine differences in impact duration, a significant difference in the mean values for each club would be required. The P-values computed from each two-sample t-test are shown in Tables 3a-b. Assuming a level of significance of 0.05, P values greater than this, which are shown in italics, indicate that the mean values of impact duration for the two clubs being compared cannot be considered to be significantly different.

It can be seen from these results that with the two-piece ball only one pair of clubs, the two traditional wooden headed clubs, have statistically similar impact durations. In rank order, the titanium club 'A' produces the longest impact duration followed by the titanium club 'B', which is followed by the two traditional style clubs. Finally, the stainless steel clubhead produces the shortest impact durations.

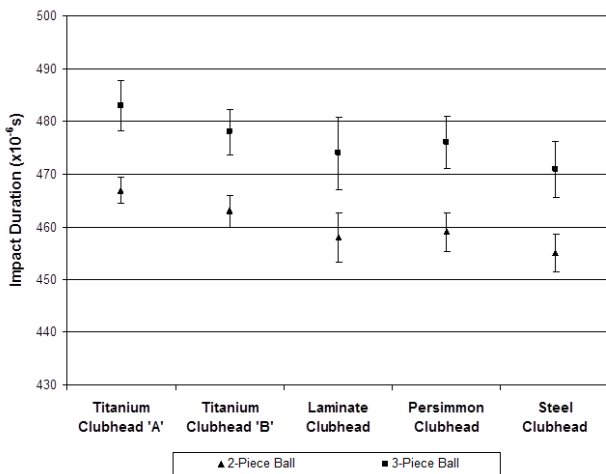

Figure 6. Mean impact durations  $\pm$  one standard deviation for two ball constructions and five clubhead types.

Table 3. Compared P-values from two sample t-tests of each club combination with two ball types (a) Two-piece balls (b) Three-piece balls

		a) Two Piece Ball			
		Titanium clubhead 'A'	Titanium clubhead 'B'	Persimmon clubhead	Laminate clubhead
Steel clubhead		0.000	0.000	0.002	0.033
Laminate clubhead		0.000	0.001	0.283	
Persimmon clubhead		0.000	0.015		
Titanium clubhead 'B'		0.001			
		b) Three Piece Ball			
		Titanium clubhead 'A'	Titanium clubhead 'B'	Persimmon clubhead	Laminate clubhead
Steel clubhead		0.000	0.000	0.006	0.197
Laminate clubhead		0.000	0.028	0.282	
Persimmon clubhead		0.000	0.165		
Titanium clubhead 'B'		0.001			

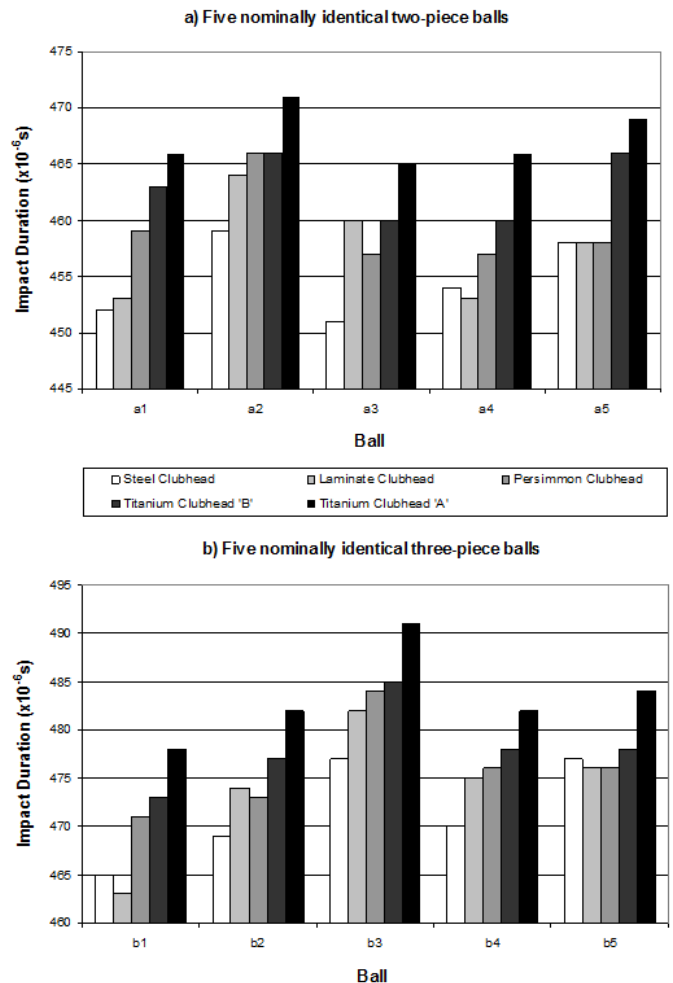

Figure 7. Effects of ball variability and clubhead type on mean impact duration using two sets of balls (a) five nominally identical two-piece balls (b) five nominally identical three-piece balls (Columns are in the same order for each ball, from steel clubhead on the left to titanium clubhead 'A' on the right).

A similar pattern emerges when the results with the three-piece, wound ball are analysed. In addition, however, the differences between the titanium club 'B' and the persimmon clubhead and the laminate wood and the stainless steel clubhead are not significant. This is attributable to the larger standard deviation of results from the three-piece wound balls compared to the two-piece balls. It can be seen from Figures 7a-b that in many cases the variation in impact duration between balls supposedly of the same construction and compression is greater than that found between clubs, which has resulted in difficulties in identifying true differences between clubs. The variability between balls of the same construction can be attributed to the tolerances in the manufacturing process resulting in varying ball compressions, particularly with the wound balls where consistency in the winding process is more difficult to achieve.

Before comparisons of the results with the golfers' perceptions can be made, the effect of clubhead speed on impact duration must be considered. Initially, the clubhead speed had been kept constant at  $44.7 \pm 0.45 \text{ ms}^{-1}$  but golfers will attain different clubhead speeds due to variations in club weight and length. In addition, differences in the strength, flexibility and ability of individual golfers will have a large effect on the clubhead speed each is able to generate. A comparison of the weights, swingweights and lengths of the test clubs is shown on Table 4. Swingweight is a measure of the weight distribution of a golf club about a fulcrum point usually 14 inches from the grip end of the club. To obtain the swingweight of a club, the moment required to balance the club about the fulcrum is measured and converted to a value on an alphanumeric scale, with A<sub>0</sub> equivalent to a moment of 161 inch-ounces and F<sub>0</sub> equivalent to 248.5 inch-ounces (in the golf industry, imperial units are still predominantly used).

It can be seen from these results that the traditional style clubs are significantly heavier and shorter than the modern clubs and it is likely that the golfer will generate less head speed with these clubs. In a separate test, which incorporated four of the five clubs used in this study, the clubhead speeds generated by fifteen elite golfers, hitting five shots with each club were measured and shown to vary from  $34.7$  to  $50.1 \text{ ms}^{-1}$  among the group. On average, the golfers swung the titanium clubhead 'B' fastest with the two traditional wooden headed clubs  $1.7 \text{ ms}^{-1}$  slower and the titanium clubhead 'A'  $0.5 \text{ ms}^{-1}$  slower.

**Table 4. Properties of clubs tested**

Club	Overall weight (g)	Swingweight	Length (in.)	Shaft material	Clubhead loft
Titanium clubhead 'A'	330	D8	45 ½	Graphite	10.5°
Titanium clubhead 'B'	309	D0	45 ¾	Graphite	8.0°
Laminate clubhead	359	C7.5	43 ½	Steel	10.0°
Persimmon clubhead	368	C9.5	43 ¾	Steel	11.0°
Steel clubhead	317	D5	44 1/2	Graphite	10.5°

As a result of the findings from this test, a second stage of testing was conducted to investigate the effect of clubhead speed and ball compression on impact duration.

### Effect of Ball Compression and Clubhead Speed on Impact Duration

Although many golf balls are graded as being nominally '90' or '100' compression, tolerances in the manufacturing process mean that, in reality, a wider range of compressions are found in each category. Sullivan and Melvin (1994) reported that '90' compression balls typically have compression values in the range 85 to 100, and '100' compression balls range from 95 to 105. Therefore, the first stage of the investigation was to identify a selection of balls of similar construction with compression values close to the standard values of 80, 90 and 100. A three piece, wound, elastomer covered ball type was selected for these tests as it could be purchased in both 90 and 100 compression ranges and it was anticipated that, on compression testing, samples as low as 80 compression would be revealed.

To determine the compression of each golf ball, an Instron 4411 Series IX Automated Materials Testing System was used to compress the balls. There is no international standard for ball compression measurement; manufacturers follow similar methods but the formulae used reveal slightly different values. For this test, the procedure used by a leading ball manufacturer was employed, which involved applying a 35.6 N (8 lbf) pre-load to the ball, followed by the application of a further 409.2 N (92 lbf). The deflection of the ball,  $x$ , from the pre-load to the final load was measured in thousandths of an inch and the compression value of the ball calculated using the following formula.

$$\text{Compression} = 188 - 2x \quad (1)$$

Each ball was loaded in three mutually perpendicular directions using the manufacturer's logo to locate the principal axis and the results averaged to give a compression rating for each ball. In total, sixty-six nominally 90 compression balls and forty-eight nominally 100 compression balls were tested. Four balls were identified with a mean compression of 81.4, standard deviation,  $\sigma = 0.5$ , which had a mean mass of 44.4 g,  $\sigma = 0.3$  g, and five balls were selected with a mean compression of 90.7,  $\sigma = 1.4$ , which had a mean mass of 45.0 g,  $\sigma = 0.1$  g. A further five balls were identified with a mean compression of 100.0,  $\sigma = 0.7$ , that had a mean mass of 45.0 g,  $\sigma = 0.1$  g.

Each of the fourteen balls was hit five times with an oversize titanium driver. Again, the club was aligned so that the impact was located at the geometric centre of the clubface with a head speed of  $44.7 \pm 0.45 \text{ ms}^{-1}$  (100 mph) immediately prior to impact.

The effect of ball compression on impact duration is illustrated in Figure 8, which shows the mean impact time for each ball plotted against its compression rating. It can



be seen that a 20-unit reduction in ball compression from 100 units results in an increase in impact duration from a mean of 446  $\mu\text{s}$  to a mean of 490  $\mu\text{s}$ . Figure 8 shows a larger difference between the 80 and 90 compression balls than between the 90 and 100 compression balls.

Finally, a single ball was selected from each compression category and struck five times at each clubhead speed ranging from  $31.3 \pm 0.45$  to  $53.6 \pm 0.45 \text{ ms}^{-1}$  ( $70 \pm 1$  to  $120 \pm 1 \text{ mph}$ ) in  $4.47 \text{ ms}^{-1}$  (10 mph) increments, as this was considered to represent the range of clubhead speeds attained by golfers from amateur level to tournament professional. Care was taken to ensure a centre impact location after each speed change. The 80, 90 and 100 compression balls selected had masses of 44.2 g, 45.2 g and 44.9 g respectively.

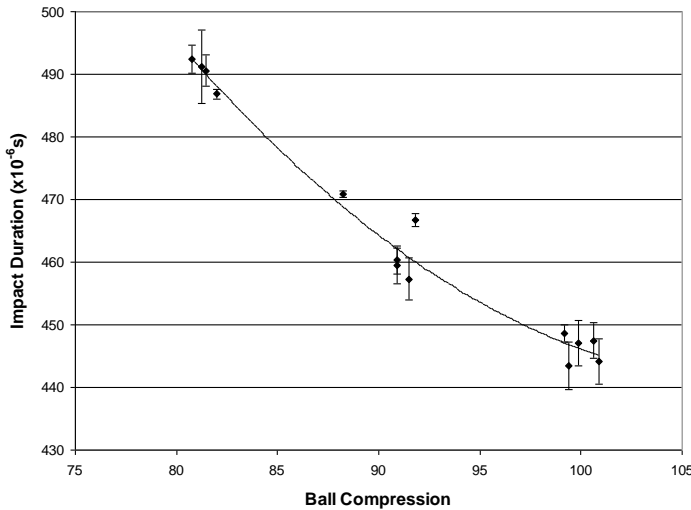

Figure 8. Mean impact durations  $\pm$  one standard deviation for samples of three different compression balls hit at  $44.7 \text{ ms}^{-1}$ .

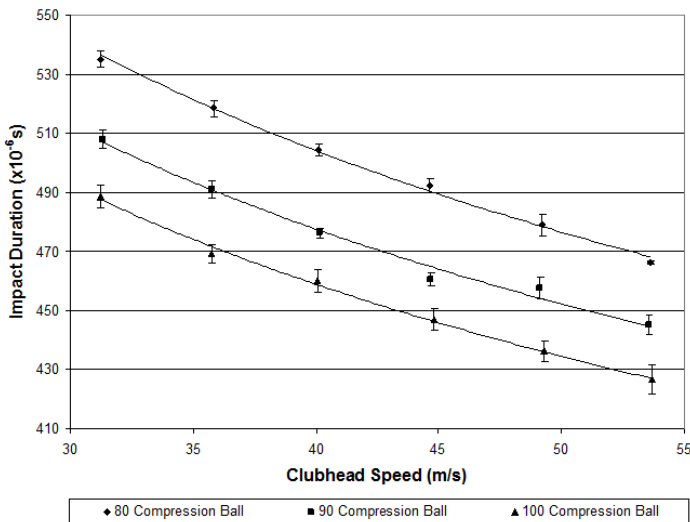

Figure 9. Mean impact durations  $\pm$  one standard deviation for three different compression balls hit over a range of clubhead speeds.

Figure 9 illustrates that, over this range, the average difference in impact duration between the 80 compression ball and the 90 compression ball was 26.1  $\mu\text{s}$  but between the 90 and 100 compression balls this difference had reduced to 18.5  $\mu\text{s}$ , consistent with the results shown in Figure 8. This suggests that there is a non-linear relationship between ball compression and impact duration.

Figure 9 also illustrates the effect of clubhead speed on impact duration within the speed range tested. Impact duration reduces as clubhead speed is increased, in this case by approximately 65  $\mu\text{s}$  over the  $22.3 \text{ ms}^{-1}$  range used, regardless of ball compression. It can also be estimated that a decrease in clubhead speed of  $1.7 \text{ ms}^{-1}$  from  $44.7 \text{ ms}^{-1}$  the clubhead speed used in the first test, will result in an increase in the duration of impact of the order of a few microseconds. Therefore, if the clubs were swung at speeds comparable with those attained by a golfer instead of at constant speed, it is predicted that the difference in impact duration between the traditional clubs and the titanium club 'B' would decrease, further reducing the statistical significance between the means.

In conclusion, the titanium club 'B' and the two traditional style clubs can be considered to give similar impact durations, with the titanium club 'A' giving statistically significantly longer durations and the stainless steel club statistically significantly shorter, with differences of the order of a few microseconds.

### Correlation Between Golfers' Perceptions and Impact Duration

The responses of the golfers interviewed in a previous study (Roberts et al., 2001) indicated that the impact duration was perceived to be longer with the traditional wooden headed clubs than with the modern titanium headed drivers. However, the results of the investigation in this paper do not correspond with the golfers' perceptions. The longest impact duration was achieved with a titanium clubhead, whilst traditional wooden heads were shown to give marginally shorter duration impacts. It is also debateable whether a human can perceive variations of a few microseconds in impact durations of less than 0.5 ms. Therefore, the golfers' perceptions appear to be influenced by other factors, indeed one of the quotes used as an example in the introduction suggests that the sound of the impact may have a significant influence. Modern, hollow, metal headed drivers tend to produce louder impact sounds that are higher pitched and last longer than the dull, quieter sounds that are produced by solid, wooden headed drivers, and these differences are discernable to the golfer.

*"[With the laminate head] it's a dead, ... dull sort of sound rather than the explosive sound you get from the metal."*

"I think the explosion is... quite an exciting sound, ... the difference is just that incredible explosion. When you strike the ball ... it makes even the weakest of hitters feel very powerful."

The explosive sound generated by metal woods may give the golfer the impression that the ball has come off the clubface quicker, with a reduced duration of impact and an increased ball velocity and is therefore thought to travel further. In addition, golfers can have preconceived ideas about different clubs, often generated by advertising claims of substantial improvements in performance that can be achieved by using titanium clubheads. This may lead the golfer to have negative opinions of older clubs and as a result describe the performance of the clubs to be worse.

It is also interesting to note that, in the first test, the ball type had a substantially greater effect on impact duration than clubhead type and yet almost half of the golfers, when questioned during the interviews, did not feel any difference.

"Again, I don't think you can feel an awful lot of difference between the two balls... either to be honest with you."

Of the remaining golfers, a number perceived a difference in the hardness of the ball but only a very few perceived a difference in the manner in which the ball came off the clubface.

"[With the two-piece ball], no sooner [have] you hit it... you've lost it, you know, it's gone... it comes off the club fairly quickly... At least with the balata one, you can feel it a little bit longer... you feel as if you've got hold of the ball a bit more."

### Hertz Law and Impact Duration Estimation

The effects of clubhead speed and ball compression illustrated in Figure 9 can be compared with theoretically obtained values. Hertz law of contact, which was originally developed for static contact, relates the contact force,  $F$  to the contact approach deformation,  $\alpha_D$ , (Goldsmith, 1960).

$$F \propto \alpha_D^{3/2} \quad (2)$$

Hertz law of contact is also applicable to colliding bodies, providing that the contact area is small compared to the dimensions of the colliding bodies and the duration of impact long in comparison with the period of the lowest mode of vibration of the bodies. Although a golf impact does not meet these requirements, Hocknell (1998) showed that a reasonable estimation of impact duration,  $\tau$ , could still be achieved with the following formula, derived from Hertz Law (Goldsmith, 1960).

$$\tau = 4.53 \left[ \frac{m_B(\delta_A + \delta_B)}{\sqrt{(R_B v_0)}} \right]^{2/5} \quad (3)$$

Where,

$$\delta_A = \frac{1-v_A^2}{\pi E_A} \quad \text{and} \quad \delta_B = \frac{1-v_B^2}{\pi E_B} \quad (4)$$

The following are typical values: for a titanium clubhead, Young's modulus  $E_A = 110 \text{ GNm}^{-2}$  and Poisson's Ratio  $\nu_A = 0.33$ , and for a golf ball, mass  $m_B = 0.0449 \text{ Kg}$  and radius  $R_B = 0.02133 \text{ m}$ . In the study by Hocknell (1998), the value of Young's modulus for the core material of a golf ball was found to be strain rate dependent. From static compression tests, a Young's modulus of  $85.7 \text{ MNm}^{-2}$  was obtained at a low strain rate, increasing to  $164.4 \text{ MNm}^{-2}$  when the strain rate was increased to the highest available of  $10 \text{ ms}^{-1}$ . In addition, a value of  $0.48$  was used for Poisson's ratio. Other studies have reported values of  $50 \text{ MNm}^{-2}$  and  $0.49$  (Thomson et al., 1990) and  $103.4 \text{ MNm}^{-2}$  and  $0.49$  (Chou et al., 1994) for Young's modulus and Poisson's ratio respectively.

Theoretical curves, obtained using values from each aforementioned study input into equation (3), are plotted alongside the experimental data in Figure 10. It can be seen that the experimental results fall well within the limits of the two extreme curves and show good agreement with the curves obtained using values of Young's modulus of  $85.7$  and  $103.4 \text{ MNm}^{-2}$ . This is perhaps unexpected considering that the strain rate of a golf ball during impact is greater than  $30 \text{ ms}^{-1}$  and it follows from the findings by Hocknell (1998) that under such loading the ball will behave in a stiffer manner and, therefore, a larger value of Young's modulus would be anticipated to be more representative. It can also be seen that the gradient of the experimental curves is marginally greater with impact durations approximately proportional to  $v_0^{-1/4}$  rather than  $v_0^{-1/5}$  as proposed by Hertz.

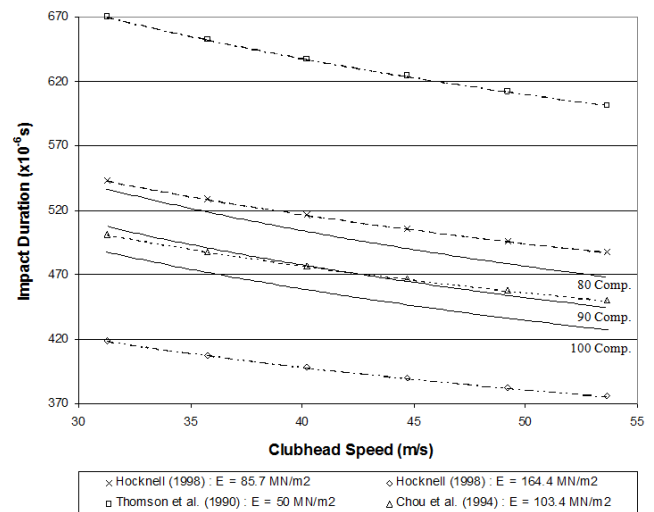

Figure 10. Comparison of experimentally and theoretically obtained values of impact duration calculated from Hertz Law using values of Young's Modulus obtained from four different studies.

### Conclusions

A technique has been developed to measure the impact duration of a golf shot using an electrical circuit in which the ball and clubface form a switch, completing the circuit whilst contact is maintained between the two bodies. The impact duration is then obtained from the

width of the electrical pulse produced. A 70  $\mu\text{m}$  thick adhesive, aluminium foil was found to be the most suitable method of applying a conductive material to the surface of a golf ball.

Investigations into the effect of clubhead type and ball construction revealed that the ball has a more significant effect on impact duration than the clubhead. The impact duration with three-piece wound balls was found to be in the region of 16  $\mu\text{s}$  longer than with two-piece balls. In contrast, the difference between the oversize titanium clubhead that produced the longest impact duration and the steel clubhead that produced the shortest was 12  $\mu\text{s}$ . The ball compression was also found to have a significant effect, with impact durations of 80 compression balls on average 44  $\mu\text{s}$  longer than 100 compression balls of the same construction. Finally, the clubhead speed at impact was found to effect impact duration, with the duration of impact reducing by approximately 65  $\mu\text{s}$  over the 22.3  $\text{ms}^{-1}$  speed range used. The experimental results showed reasonable agreement with theoretically obtained values but, when compared with golfers' perceptions, little correlation was found. This suggests that the perceptions of golfers are influenced by other factors, such as the sound of the impact.

### Acknowledgements

The authors acknowledge the contribution of Tim Roberts to the work presented in this paper. The authors would also like to thank the Wolfson School of Mechanical and Manufacturing Engineering for providing facilities and technical staff that enabled the project to be conducted.

### References

Armstrong, C.W., Levendusky, T.A., Eck, J.S., Spyropoulos, P. and Kugler, L. (1988). Influence of Inflation Pressure and Ball Wetness on the Impact Characteristics of Two Types of Soccer Balls. In *Science and Football: Proceedings of the First World Congress of Science and Football*, (edited by T. Reilly), pp. 394-398. E & FN Spon.

Asai, T. and Akatsuka, T. (1998). Computer Simulation of Curve-Ball Kicking in Soccer. In *The Engineering of Sport*, (edited by S. J. Haake), pp. 433-440. Blackwell Science Ltd., Oxford, UK.

Baker, J.A. and Putnam, C.A. (1979). Tennis Racket and Ball Responses During Impact Under Clamped and Freestanding Conditions. *Research Quarterly*, 50(2), pp. 164-170.

Chou, P.C., Liang, D., Yang, J. and Gobush, W. (1994). Contact Forces, Coefficient of Restitution and Spin Rate of Golf Ball Impact. In *Science and Golf II: Proceedings of the 1994 World Scientific Congress of Golf*, (edited by A. J. Cochran and M. R. Farrally), pp. 298-301. E & FN Spon, London.

Cochran, A. and Stobbs, J. (1968). *The Search For The Perfect Swing*. Heinemann, London, UK.

Cross, R. (1999). The Bounce of a Ball. *American Journal of Physics*, 67, pp. 222-227.

Gobush, W. (1990). Impact Force Measurements on Golf Balls. In *Science and Golf: Proceedings of the First World Scientific Congress of Golf*, (edited by A. J. Cochran), pp. 219-224. E & FN Spon, London.

Goldsmith, W. (1960). *Impact: The Theory and Physical Behaviour of Colliding Solids*. Edward Arnold (Publishers) Ltd., London.

Hendee, S.P., Greenwald, R.M. and Crisco, J.J. (1998). Static and Dynamic Properties of Various Baseballs. *Journal of Applied Biomechanics*, 14, pp. 390-400.

Hocknell, A. (1998). *Computational and Experimental Analysis of Elastic Deformation in Impact*. PhD Thesis, Loughborough University, Loughborough, UK.

Johnson, W., Reid, S.R. and Trembaczowski-Ryder, R.E. (1973). The Impact, Rebound and Flight of a Well Inflated Pellicle as Exemplified in Association Football. *The Manchester Association of Engineers*, 5, pp. 1-25.

Levendusky, T.A., Armstrong, C.W., Eck, J.S., Jeziorowski, J. and Kugler, L. (1988). Impact Characteristics of Two Types of Soccer Balls. In *Science and Football: Proceedings of the First World Congress of Science and Football*, (edited by T. Reilly), pp. 385-393. E & FN Spon, London.

Roberts, J., Jones, R., Harwood, C., Mitchell, S. and Rothberg, S. (2001). Human Perceptions of Sports Equipment under Playing Conditions. *Journal of Sports Sciences*, 19, pp.485-497.

Scheie, C.E. (1990). The Golf Club-Ball Collision - 50,000 g's. In *Proceedings of the First World Scientific Congress of Golf*, (edited by A. J. Cochran), pp. 237-240. E & FN Spon, London.

Sullivan, M.J. and Melvin, T. (1994). The Relationship Between Golf Ball Construction and Performance. In *Science and Golf II: Proceedings of the 1994 World Scientific Congress of Golf*, (edited by A. J. Cochran and M. R. Farrally), pp. 334-339. E & FN Spon, London.

Thomson, R.D., Whittaker, A.R., Wong, K. and Adam, A. (1990). Impact of a Golf Ball with a Rigid Clubface. In *Proceedings of the 6th UK ABAQUS User Group Conference*, (edited by S. Brundrett and J. G. Redhead), pp. 41-47. UK ABAQUS User Group Committee.

Tsaousidis, N. and Zatsiorsky, V. (1996). Two Types of Ball-Effector Interaction and their Relative Contribution to Soccer Kicking. *Human Movement Science*, 15, pp. 861-876.

Ujihashi, S. (1994). Measurement of Dynamic Characteristics of Golf Balls and Identification of their Mechanical Models. In *Science and Golf II: Proceedings of the 1994 World Scientific Congress of Golf*, (edited by A. J. Cochran), pp. 302-308. E & FN Spon, London.