

This item was submitted to Loughborough University as an EngD thesis by the author and is made available in the Institutional Repository (<https://dspace.lboro.ac.uk/>) under the following Creative Commons Licence conditions.



creative
commons
COMMONS DEED

Attribution-NonCommercial-NoDerivs 2.5

You are free:

- to copy, distribute, display, and perform the work

Under the following conditions:

 **BY:** **Attribution.** You must attribute the work in the manner specified by the author or licensor.

 **Noncommercial.** You may not use this work for commercial purposes.

 **No Derivative Works.** You may not alter, transform, or build upon this work.

- For any reuse or distribution, you must make clear to others the license terms of this work.
- Any of these conditions can be waived if you get permission from the copyright holder.

Your fair use and other rights are in no way affected by the above.

This is a human-readable summary of the [Legal Code \(the full license\)](#).

[Disclaimer](#) 

For the full text of this licence, please go to:
<http://creativecommons.org/licenses/by-nc-nd/2.5/>

Repair and Corrosion Management of Reinforced Concrete Structures

Christos Christodoulou

**AECOM
Colmore Plaza
20 Colmore Circus Queensway
Birmingham
B4 6AT**

**Centre for Innovative and Collaborative
Construction Engineering
School of Civil & Building Engineering
Loughborough University
Loughborough
Leicestershire, LE11 3TU**

[This page is left intentionally blank]

[This page is left intentionally blank]

[This page is left intentionally blank]

REPAIR AND CORROSION MANAGEMENT OF REINFORCED CONCRETE STRUCTURES

By
Christos Christodoulou

A dissertation thesis submitted in partial fulfilment of the requirements for the award of the degree Doctor of Engineering (EngD), at Loughborough University

November 2013

© by Christos Christodoulou 2013

AECOM
Colmore Plaza
20 Colmore Circus Queensway
Birmingham
B4 6AT

Centre for Innovative and Collaborative Construction
Engineering
School of Civil & Building Engineering
Loughborough University
Loughborough
Leicestershire, LE11 3TU

[This page is left intentionally blank]

ACKNOWLEDGEMENTS

This research would have not been possible without the funding and support of the Engineering and Physical Sciences Research Council, Loughborough University, Centre of Innovative and Collaborative Engineering, AECOM Ltd, Highways Agency, The Highland Council and Northampton Borough Council. I would like to express my sincere gratitude to all of the aforementioned organisations.

I would like to extend my gratitude to supervisors and life-long mentors Dr. Chris Goodier, Prof. Simon Austin, Dr. Gareth Glass and John Webb. Without their guidance, mentoring and wisdom it would have not been possible to complete this EngD programme. Also, a big thank you goes to Neil Parkes who provided me with invaluable hands-on support and for all the long days we spent in the laboratory.

Finally my deepest gratitude goes to my family and my partner, Anna, for their continuous and unconditional encouragement, support and understanding.

[This page is left intentionally blank]

ABSTRACT

The durability of concrete structures is affected by a number of factors such as environmental exposure, electrochemical reactions, mechanical loading, impact damage and others. Of all of these, corrosion of the reinforcement is probably the main cause for the deterioration of steel reinforced concrete (RC) structures.

Corrosion management is becoming increasingly necessary as a result of the growing number of ageing infrastructure assets (e.g. bridges, tunnels etc.) and the increased requirement for unplanned maintenance in order to keep these structures operational throughout their design life (and commonly, beyond). The main RC repair, refurbishment and rehabilitation approaches generally employed can be broadly categorised under a) conventional, b) surface treatments, c) electrochemical treatments and d) design solutions.

The overarching aim of this research was to identify the key corrosion management techniques and undertake empirical investigations focused on full-scale RC structures to investigate their long-term performance.

To achieve this, individual research packages were identified from the above broad five approaches for repair, replacement and rehabilitation. These were 1) Patch repairs and incipient anodes, 2) Impressed Current Cathodic Protection, 3) Galvanic Cathodic Protection and 4) Hydrophobic treatments.

The selection of the above research packages was based on past and present use by the construction industry to repair, refurbish and rehabilitate RC structures. Their contributions may be broadly categorised as i) Investigations on how specific treatments and materials perform, ii) Investigations on the effectiveness of existing methods of measurements and developing alternatives, iii) Changes to the existing theory of corrosion initiation and arrest and iv) Changes to management framework strategies.

The key findings from each research package can be summarised as follows:

- Macrocell activity appears to be a consequence rather than a cause of incipient anode formation in repaired concrete structures, as has previously been presented;
- ICCP has persistent protective effects even after interruption of the protective current;
- Discrete galvanic anodes installed in the parent concrete surrounding the patch repair are a feasible alternative to galvanic anodes embedded within the patch repairs of RC structures;
- Silanes may have a residual hydrophobic effect even after 20 years of service.

KEY WORDS

Reinforced concrete; Corrosion; Impressed Current Cathodic Protection; Impedance; Hydrophobic treatments; Silanes; Galvanic Cathodic Protection; Patch repairs; Incipient anodes.

Word Count: 17,892

PREFACE

This thesis represents research undertaken between 2009 and 2013 in partial fulfilment of the requirements for the award of the degree Doctor of Engineering (EngD), at Loughborough University, Leicestershire, UK.

The research was funded by the Engineering and Physical Sciences Research Council (EPSRC) through the Centre for Innovative and Collaborative Engineering (CICE) and AECOM Ltd. The research was undertaken between 2009 and 2013 and was supported by the Highways Agency, The Highlands Council and Northampton Borough Council who provided access to their assets for the investigations.

This thesis describes research from four distinct work packages which looked at means and methods on the corrosion management strategies employed with regards to the repair, refurbishment and rehabilitation of reinforced concrete structures.

The thesis has five main Chapters, as required by Loughborough University's Centre for Innovative and Collaborative Engineering (CICE) regulations:

- Section 1 discusses the general subject domain (of RC corrosion management) and the context upon which the research work is based. Details of the industrial sponsor are also provided, together with the key benefits to them as an organisation.
- Section 2 highlights the objectives of the work and how they contribute towards one overarching aim.
- Section 3 provides a description of the methodology employed and the experimental procedures for each research package.
- Section 4 provides an overarching discussion of the research undertaken and makes direct reference to the achieved publications.
- Section 5 highlights the key findings of the research, contributions to the industry and theoretical knowledge, the benefits to the industrial sponsor and recommendations for future areas of research.

[This page is left intentionally blank]

ACRONYMS / ABBREVIATIONS

Ag/AgCl	Silver/Silver Chloride
CICE	Centre for Innovative and Collaborative Engineering
Cu/CuSO ₄	Copper/Copper Sulphate
GCP	Galvanic Cathodic Protection
HA	Highways Agency
ICCP	Impressed Current Cathodic Protection
MLMV	Midland Links Motorway Viaducts
mA	milliampere
mm	millimetre
mV	millivolt
MSCP	Multi-Storey Car Park
pH	Measure of acidity of a solution
RC	Reinforced Concrete
TRB	Transportation Research Board
UK	United Kingdom

[This page is left intentionally blank]

CONTENTS

Acknowledgements	i
Abstract	iii
Key Words	iv
Preface	v
Acronyms / Abbreviations	vii
Contents	ix
Figures	xi
Tables	xiii
Papers	xv
1 Background to the Research	1
1.1 The Subject Domain	1
1.2 The Industrial Sponsor.....	4
1.3 The Context of the Research	5
2 Aim and Objectives	11
2.1 Background	11
2.2 Aim	18
2.3 Objectives	18
3 Methodology	21
3.1 Methodological Considerations.....	21
3.2 Methodology Development and Refinement	24
3.3 Methods	26
4 The Research	31
4.1 Concrete Repair – Research Package 1 (Appendix B)	31
4.2 Impressed Current Cathodic Protection – Research Package 2 (Appendices C and D).....	42
4.3 Galvanic Anodes – Research Package 3 (Appendix E).....	55
4.4 Hydrophobic Treatments – Research Package 4 (Appendix F)	66
5 Findings and Implications	75
5.1 Summary of key Findings	75
5.1.1 Performance of Treatments and Materials	76
5.1.2 Methods of Measurement	79
5.1.3 Contribution to Existing Theory and Practice	80
5.1.4 Implications for the Management of RC Structures.....	83
5.2 Implications/Impact on industrial sponsor and Wider Industry.....	84
5.3 Recommendations for Industry/Further Research.....	88
5.4 Critical Evaluation of the Research.....	90
6 References	93
Appendix A LIST OF ADDITIONAL PUBLICATIONS	101
Appendix B Paper 1	103
Appendix C Paper 2	121

Appendix D Paper 3.....139
Appendix E Paper 4.....157
Appendix F Paper 5.....175

FIGURES

Figure 1.1	Categorisation of corrosion management techniques based on the nature of the works.....	3
Figure 1.2	Interpreted Pourbaix diagram, illustrating the thermodynamic stability of iron oxides in varying conditions. (Glass et al. 2007)	6
Figure 1.3	Process of corrosion on steel in concrete (Glass et al. 2006).....	8
Figure 3.1	Overall classification of research (Brewer 2007).	23
Figure 4.1	Effect of a repair (material A, MSCP) on the relative potential determined at the concrete surface after curing over varying periods of time (Christodoulou et al. 2013).....	33
Figure 4.2	Effect of a repair (material B, Bridge) on the steel potentials determined at the concrete surface after curing over varying periods of time (Christodoulou et al. 2013).	35
Figure 4.3	Effect of a repair (material C, Bridge) on the steel potentials determined at the concrete surface after curing over varying periods of time (Christodoulou et al. 2013).	36
Figure 4.4	Three schematic cases showing potential changes between parent and repair concrete (Christodoulou et al. 2013).....	38
Figure 4.5	Typical sub-structure arrangement of the MLMV.....	43
Figure 4.6	Steel potentials of the 10 structures monitored over a period of 33 months (Christodoulou et al. 2010).....	46
Figure 4.7	Corrosion rates summary from polarisation resistance testing over a period of 33 months (Christodoulou et al. 2010).....	48
Figure 4.8	Typical impedance plot arising following analysis of transient data (Christodoulou et al. 2010).....	50
Figure 4.9	Corrosion rates summary from transient analysis testing over a period of 33 months (Christodoulou et al. 2010).	52
Figure 4.10	MSCP structural arrangement	56
Figure 4.11	Bridge structural arrangement	56
Figure 4.12	Polarisation effect of the anodes at a distance from the edge of a patch repair in the MSCP with material type A over a period of 215 days following installation.	59
Figure 4.13	Polarisation effect of anodes at a distance from the edge of a patch repair from the bridge structure, with material type B, 30 days following installation.	61
Figure 4.14	Potential mapping around a repair location with Material A up to 195 days following installation of the galvanic anodes.....	63
Figure 4.15	Diagrammatic outline of the patch repair and the location of anodes.	64
Figure 4.16	Categories of surface treatments a) coatings, b) pore blockers and c) pore liners (Medeiros and Helene 2009).....	66
Figure 4.17	Typical sub-structure arrangement of the MLMV.....	67
Figure 4.18	Average cumulative absorption for each structure's group of specimens over 4 hours of capillary absorption testing.....	70

TABLES

Table 3.1	Methodological considerations employed for each objective of this work.....	24
Table 3.2	Summary of the testing methods and expected outcomes for each objective of this research.	27
Table 4.1	Repair materials, location applied, and brief description of properties	32
Table 4.2	Details of the 10 selected structures	44
Table 4.3	Factors affecting the performance of galvanic anode systems applied to RC structures (Christodoulou et al. 2008).....	55
Table 4.4	Repair materials, location used and brief description of properties	57
Table 4.5	Structures details based on an average construction date of 1969.	68
Table 4.6	Initial, intermediate and average rate of water absorption in $\text{g}/\text{m}^2/\text{h}^{0.5}$ for each structure's group of specimens based on 4 hours of capillary absorption testing.	71
Table 5.1	Summary of contributions from each publication and objective against four main strands.....	76
Table 3:	Details of the 10 structures investigated by Christodoulou et al. 2010 [1].....	145

[This page is left intentionally blank]

PAPERS

The following papers, included in appendices B to F, have been produced during the course of the research in partial fulfilment of the award requirements of the Engineering Doctorate.

PAPER 1 (APPENDIX B)

Christodoulou C, Goodier C, Austin S, Webb J and Glass G, Diagnosing the cause of incipient anodes in repaired reinforced concrete structures, *Corrosion Science*, 69 (2013), pp. 176 – 183 DOI information: 10.1016/j.corsci.2012.11.032

PAPER 2 (APPENDIX C)

Christodoulou C, Glass G, Webb J, Austin S and Goodier C, Assessing the long term benefits of Impressed Current Cathodic Protection, *Corrosion Science*, 52 (2010), pp. 2671 – 2679 DOI information: 10.1016/j.corsci.2010.04.018

PAPER 3 (APPENDIX D)

Christodoulou C, Goodier C, Austin S, Glass G and Webb J, On-site transient analysis for the corrosion assessment of reinforced concrete, *Corrosion Science*, 62 (2012), pp. 176 – 183 DOI information: 10.1016/j.corsci.2012.05.014

PAPER 4 (APPENDIX E)

Christodoulou C, Goodier C, Austin S, Glass G and Webb J, A new arrangement for galvanic anodes in the repair of reinforced concrete structures, *Construction and Building Materials*, 50 (2014), pp. 300 – 307 DOI information: 10.1016/j.conbuildmat.2013.09.062

PAPER 5 (APPENDIX F)

Christodoulou C, Goodier C, Austin S, Webb J, Glass G, Long-term performance of surface impregnation of reinforced concrete structures with silane, *Construction and Building Materials*, 48 (2013), pp. 708 – 716 DOI information: 10.1016/j.conbuildmat.2013.07.038

1 BACKGROUND TO THE RESEARCH

This chapter presents an introduction to the context of the research undertaken. It also provides details of the Industrial Sponsor, motives for undertaking the research and benefits.

1.1 THE SUBJECT DOMAIN

Reinforced concrete (RC) structures are an essential part of society's infrastructure and the number of these types of asset has increased considerably with over three quarters of the current bridge stock built after 1960 (Wallbank 1989). However, their long-term performance is affected by various factors such as environmental exposure, electrochemical reactions, mechanical loading, impact damage and others. In a survey of 200 bridge structures in the UK, it was identified that at least 30% of those examined were in poor conditions as a result of spalling, rusting and cracking (Wallbank 1989).

Chloride-induced corrosion of the reinforcement is considered the main deterioration cause of RC structures (Glass and Buenfeld 1996, British Standards Institution 2008, Glass 2007). This is associated with the currently high use of de-icing salts during winter maintenance which is reported to be as much as 7 times as in early 1960s (Wallbank 1989).

Corrosion management started to be exercised more rigorously in the UK in the 1980's as a result of an increasing bridge stock requiring maintenance and deterioration affecting a large number of bridges which were only in the first 20 years of their design life. It was at this time that Impressed Current Cathodic Protection (ICCP) was successfully trialled in the Midland Links Motorway Viaducts (Corrosion Prevention Association 2011). This benefited a large number of aging transportation infrastructure assets (i.e. bridges, tunnels etc.) which required unplanned maintenance in order to keep them operational throughout their design life.

Over the past 30 years, a number of approaches have been established and followed by asset owners and managing agent contractors. All aim to stop on-going deterioration and extend the service life of the structures.

Techniques previously employed can be broadly categorised in the following four approaches:

1. Conventional
2. Surface treatments
3. Electrochemical treatments
4. Design solutions

Figure 1.1 provides a comprehensive, but non-exhaustive, summary of the various techniques and how these fit under the above approaches.

The first two approaches form short-to medium-term strategies which involve monitoring the structure, repairing defective only areas or replacing contaminated concrete to a design chloride ion threshold, or offering corrosion prevention by limiting contamination of corrosion inducing ionic species. Nevertheless, concrete patching remains the most common repair technique.

Electrochemical treatments are medium-to long-term strategies and nowadays are the most popular form of corrosion management after concrete repairs, as chloride-induced corrosion is the main deterioration cause of atmospherically exposed RC structures.

In contrast, design solutions form part of long-term strategies. They are associated with a high capital cost and tend to either affect the function of the structure or replace it when deterioration is severe.

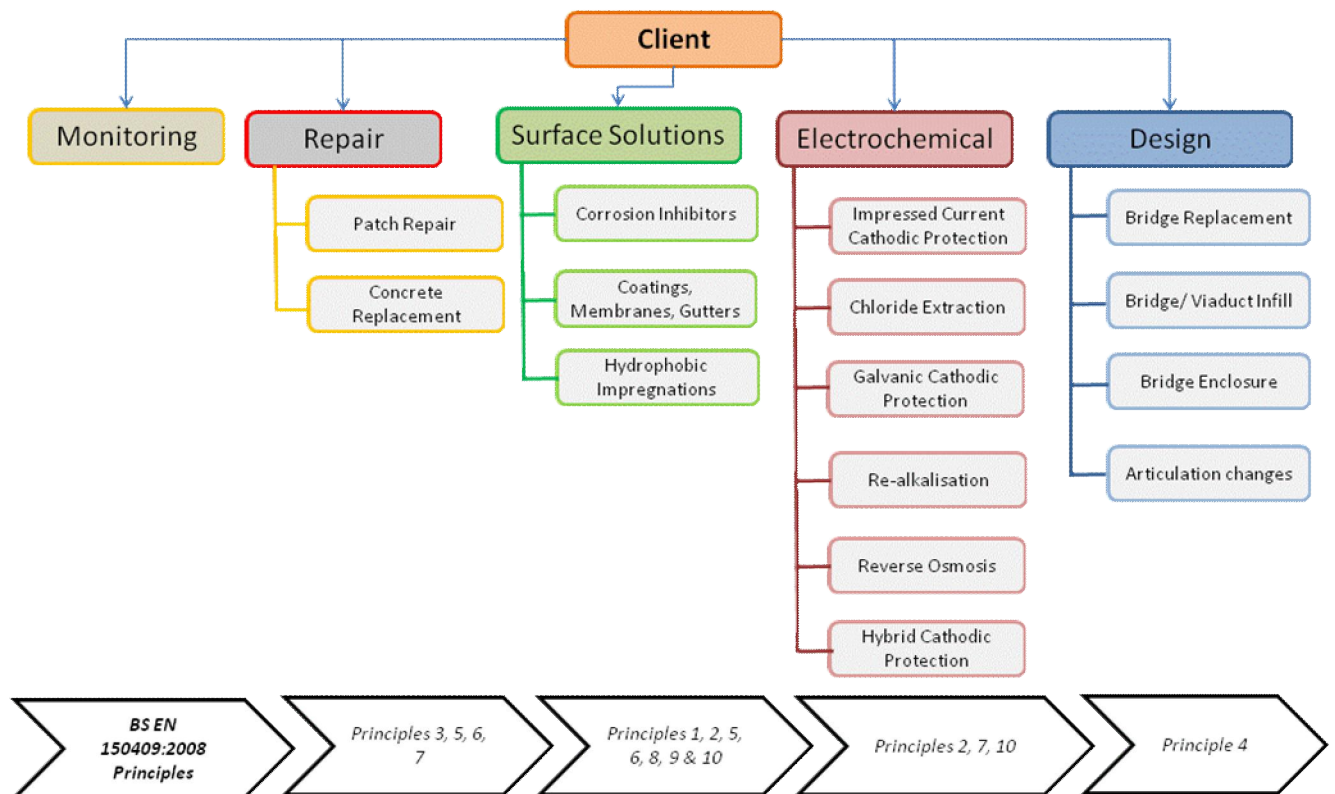

Figure 1.1 Categorisation of corrosion management techniques based on the nature of the works

Although these techniques have been used to varying extents for the repair, refurbishment and rehabilitation of corroding RC structures and subsequent extension of their service life, there is limited rigorous empirical evidence, however, of their long-term performance and how they have driven advances in corrosion management strategies for RC structures.

The aim of this research was to identify the key corrosion management techniques, gather available monitoring data and develop complimentary empirical investigations focused on full-scale RC structures. The benefits of undertaking this research included savings in overall corrosion management as a result of extended service life of the RC structures and the associated repair, refurbishment or rehabilitation technique employed and also as a result of reductions in costs of maintenance and monitoring.

A key differentiation of this research from previous studies is that it is focused on testing full-scale RC structures, such as the elevated sections of the M5 and M6 motorways, in order to

improve corrosion management and maintenance (with opportunities for immediate implementation). In doing so, the research also undertook laboratory testing to verify observations made in the field, and to test hypotheses.

1.2 THE INDUSTRIAL SPONSOR

AECOM UK Ltd, a multi-disciplinary international consultancy was the industrial sponsor for this work. It has grown over the past 20 years from an engineering and technology firm to become a one-stop shop of consultancy services to engineering and infrastructure clients. In the UK, AECOM acquired G. Maunsell and Partners in 1999, then bought Oscar Faber in 2002, formed the FaberMaunsell brand in 2003 and in 2010 rebranded to AECOM.

AECOM has a number of operating divisions, including Transportation. The bridges and structures group is part of Transportation and it has been involved in the design, repair, refurbishment and rehabilitation of a large number of structures. The team operating from the Birmingham office (UK) has been involved for over 20 years with the maintenance of the UK's Midland Links Motorway Viaducts (MLMV), which consists of 21 kilometres of elevated motorway bridge structures around the city of Birmingham.

The company has been involved with the implementation of a number of corrosion management techniques and has historically been keen to develop new technologies and applications for the industry. With an increasing number of installed corrosion management systems slowly reaching the end of their design life, the company was motivated to invest in research investigating their long-term performance, thus providing a more holistic approach to corrosion management and consequently a greater value of service to clients.

The principal benefits of this research to the industry and the industrial sponsor may be summarised below:

- Increased service life of RC structures through improved and holistic corrosion management strategy
- A more rational approach to the assessment of repair options
- Improvements in monitoring and maintenance strategies
- Commercial competitiveness
- Development of links with the academia, research groups, professional bodies and institutions and influence design standards and best practice

AECOM, as a delivery partner for the asset management of the MLMV, has also been liaising directly with asset owners such as the UK government's Highways Agency (HA). This relationship helped the research gain access to RC bridge structures.

In addition, working in close partnership with the HA helped to critically assess the aim, objectives, research packages and deliverables from an asset owner's perspective and ensure that it was focused on delivering tangible benefits.

1.3 THE CONTEXT OF THE RESEARCH

Deterioration of RC structures can be attributed to a range of factors and can occur either due to deterioration of the concrete, the reinforcement, or both. The principal causes for deterioration of concrete are structural damage, chemical attack or physical damage (British Standards Institution 2008).

Reinforcement will deteriorate mainly due to corrosion, which is an electrochemical process. The two most common causes of reinforcement corrosion are chlorides and carbonation. This work was focused on chloride-induced deterioration of concrete structures as these have the potential for substantially greater damage.

Concrete under normal circumstances provides a non-aggressive and highly alkaline environment with a pH above 13. As can be observed from Figure 1.2, under these conditions the steel remains passive and develops an oxide film which covers its surface and presents a barrier to further metal dissolution (Page and Treadaway 1982, Glass and Buenfeld 1996).

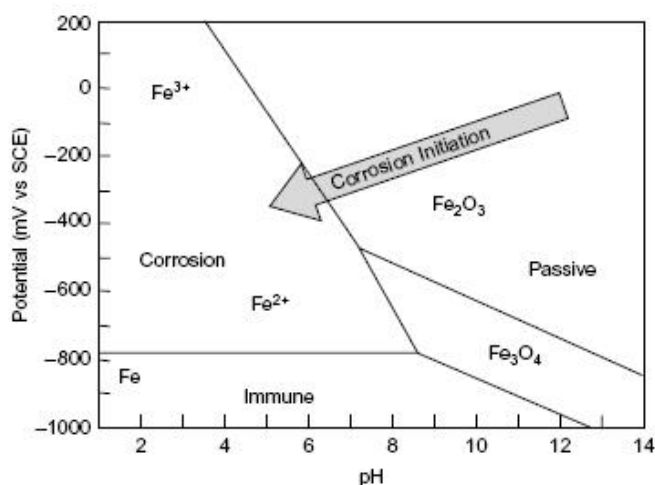

Figure 1.2 Interpreted Pourbaix diagram, illustrating the thermodynamic stability of iron oxides in varying conditions. (Glass et al. 2007)

Chloride contamination can induce severe localised corrosion of the reinforcement (Alvarez and Galvele 1984). There are numerous case studies of structures suffering from corrosion and it is costing billions of pounds to the global economy every year (Smith and Virmani 2000). Once the chloride content exceeds a certain limit, known as chloride threshold, corrosion will initiate as a result of the oxide film breakdown (Everett and Treadaway 1980, American Concrete Institute 1985). Currently, this limit is expressed in terms of total chloride (bound and free). Measured levels range from 0.2 to more than 2% by weight of cement. This wide range indicates that corrosion initiation is subject to a number of factors and not only to chloride levels (Glass and Buenfeld 1997, Glass et al 2000, Sergi and Glass 2000, Angst 2009).

Chloride attack tends to be localised and the film breakdown tends to follow the model of pitting corrosion and pit growth (Glass et al. 2000). If the pits are to grow, pit nucleation must be followed by a fall in pH and increase in chloride content at the pit nucleation site. The local fall in pH will occur from the hydrolysis of dissolving iron ions, as expressed from Equation 1.



The dissolving ions react with water to form iron hydroxides and hydrogen ions (anodic reaction). The remaining free electrons flow through the steel to the cathodic site where they are consumed together with dissolved oxygen to form hydroxyl ions (OH-) (cathodic reaction). Based on the principle of electro neutrality, charge build up is prevented by the hydroxyls flowing towards the anode. They electrically neutralise each other and form ferrous hydroxide Fe(OH)₂ which when mixed with oxygen will form haematite Fe₂O₃.3H₂O a by product of the corrosion circle, otherwise known as “red-brown rust”.

The positively charged hydrogen ions are balanced at the anode by the presence of negative charged chloride ions, combined to produce hydrochloric acid (Figure 1.3). The amount of oxygen supply is critical at the cathode for sustaining the reaction. For submerged RC structures, corrosion will not easily initiate as the supply of oxygen is limited. However, oxygen deficient reactions may be serious as they tend to develop for a considerable time before any visible evidence. In such cases, the rust may be green which is believed to be a complex chemical composition based on chlorides or black as a product of magnetite (Fe₃O₄).

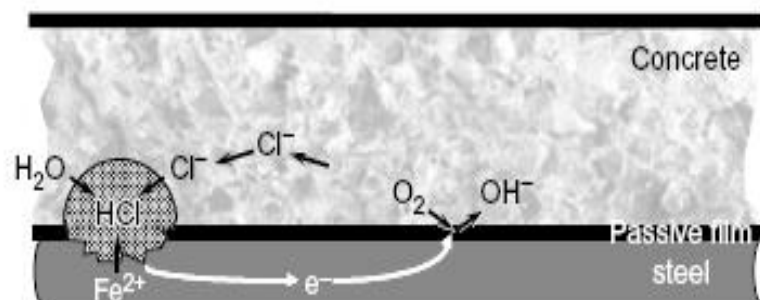

Figure 1.3 Process of corrosion on steel in concrete (Glass et al. 2006)

Having established the primary causes of chloride-induced deterioration of RC structures and the associated mechanism, it is equally important to recognise the mode of transport in order to apply effective corrosion management strategies.

Chloride ions may be cast into the concrete due to contaminated construction materials or processes or due to the use of accelerators. Such problems are not commonly encountered in new build structures in the UK as chloride-based accelerators, like calcium chloride, has been restricted since the 1970s and quality control has increased (British Standards Institution 1988). Thus, chloride-induced corrosion tends to be a result of exposure to marine environments, including sea water splash and spray, and the use of de-icing salts which are applied on the surface of RC structures during winter maintenance (Bamforth et al 1997).

Concrete is a naturally porous material. The size and distribution of pores in concrete vary and depend on the constituent materials, quality of compaction, mix design, the water-to-cement ratio, the degree of hydration, and curing (Concrete Society 2008). Some of these pores will be interconnected to form a network of pore space that can be penetrated by water, gas or ions.

The relevant transport mechanisms for the ingress of water, gases and ions are (Kropp and Hilsdorf 1995):

- capillary absorption of liquids due to surface tension acting in capillaries

- diffusion of free molecules or ions due to a concentration difference
- permeation of gases such as carbon dioxide and oxygen
- permeation of water due to hydraulic pressure difference

Although, these mechanisms act together under natural environmental exposure conditions for atmospherically exposed concrete, capillary absorption tends to be the dominant mechanism (Kropp and Hilsdorf 1995, Concrete Society 2008). Therefore, chloride ions, which are dissolved in water, are transported into the concrete pore system by means of capillary absorption during alternating wetting and drying cycles. The chlorides will be transferred further into the concrete as a result of diffusion that is occurring because of concentration gradients between the cover zone and the inner mass of the concrete structure.

Employing corrosion management strategies that can arrest the electrochemical corrosion process or ones which prevent the transport of corrosion inducing species can result in significant enhancements to the durability of concrete.

[This page is left intentionally blank]

2 AIM AND OBJECTIVES

This section describes the aim and objectives of the research together with a justification for their selection.

2.1 BACKGROUND

As discussed previously in section 1.1, corrosion management of RC structures can be broadly divided into four broad approaches, with each one including several corrosion management techniques. Corrosion is an electrochemical process and in the majority of cases the contributing cause is chloride contamination. Chlorides may be cast into the concrete or may be transported within it as a result of exposure to marine environments or use of de-icing salts during winter maintenance. For the above reasons, corrosion management is usually focused on the following three approaches from the list discussed previously:

- Conventional
- Electrochemical treatments
- Surface treatments

The objectives of this work were developed from the individual corrosion management techniques belonging to the three general approaches described above, in order to identify savings as a result of reduced costs of maintenance and monitoring from which asset owners such as the HA can benefit, while at the same time extending the service life of their assets.

As the nature of the EngD programme is to undertake industrially supported research, the research objectives were developed over time. The driver for their development was the current requirements of the industry and of course the industrial sponsor's relationship with clients. Electrochemical treatments are the most commonly used techniques for the refurbishment and rehabilitation of RC structures. The research initially examined the performance of electrochemical treatments such as ICCP. Based on the findings, additional

work was undertaken on relevant themes such as alternative electrochemical treatments, patch repairs and surface treatments. This can be briefly summarised in the resulting publication plan included in Appendix A.

2.1.1 Conventional

Patching of RC is the most common repair technique and involves the removal of physically deteriorated concrete, cleaning of the steel reinforcement and replacing the cover with a repair mortar. The aim is to eliminate the cause of original deterioration and provide protection to the repaired area against future deterioration, thus making the steel within the repair passive (Qian et al. 2006, Tilly and Jacobs 2007, Dugarte and Sagues 2009). If the approach is targeted to only physically deteriorated areas, the fundamental cause of corrosion initiation may not be always properly addressed.

In contrast, concrete replacement usually involves removing all chloride-contaminated concrete above a critical threshold level assumed to initiate corrosion. For example, HA's advice note BA 35/90 (DMRB 1990) advises that, generally, where chloride ion contents at the level of the reinforcement exceed 0.3% (total chloride ion content) by weight of cement and half-cell potential measurements are numerically greater than -350 mV (against a copper/copper sulphate reference electrode), there is a high risk of corrosion and concrete in these areas should be removed. Although this approach targets the cause of corrosion initiation it can become a prohibitive technique for large scale structures due to high capital costs.

In many cases further corrosion deterioration has been observed around concrete patch repairs after a few months to a year following completion of the repair process (Qian et al. 2006, Broomfield 2007). This phenomenon is usually known as the incipient or ring anode

formation (Page and Sergi 2000, Bertolini et al. 2004). The concept that macrocell activity (the formation of spatially separated anodes and cathodes) causes the incipient anode effect was first introduced by Page and Treadaway (1982). They suggested that the redistribution of anodic and cathodic sites following concrete repair affects future corrosion risk. Since that time, macrocell diagnosis developed to the extent that it is almost exclusively considered as the cause of incipient anode formation in the corrosion literature (Page and Sergi 2000, Bertolini et al. 2004, Broomfield 2007, Concrete Society 2011, British Standards Institution 2012).

However, studies by Chadwick (1993), Morgan (1996) and Cleland et al. (1997) demonstrated that there are additional contributory effects to the formation of incipient anodes, which are usually ignored. This observation developed the basis for *research package I* of this work. More detailed background information can be found in Appendix B.

Undertaking investigations on full-scale RC structures would provide very useful information on the actual causes and consequences for the formation of incipient anodes following patch repairs. The findings would help to increase the current understanding of the corrosion initiation mechanism following a repair and also develop more rigorous and durable corrosion management strategies.

2.1.2 Electrochemical Treatments

The corrosion management techniques within this approach target into controlling and changing the electrochemical reactions that take place within the concrete and around the area of the steel reinforcement. They can be briefly summarised as:

- Impressed Current Cathodic Protection (ICCP)

- Chloride Extraction
- Galvanic Cathodic Protection (GCP)
- Hybrid Corrosion Protection

ICCP is generally regarded as the only solution that can directly stop corrosion, even in the most corrosive environment (Transportation Research Board 2009). The first known full-scale ICCP system to be installed on a RC bridge was on the Sky Park bridge in Placerville, California, 1972 (Stratfull 1973). In the UK preliminary trials were undertaken in the early 1980s, with the first full-scale trial in 1986, on the MLMV over an area of 200 m² of reinforced concrete structure. The trial was successful and over the years ICCP was employed as one of a wide range of corrosion management options. The first fully operational ICCP system was installed and commissioned by July 1991 and it is still operational today (Christodoulou et al. 2013).

ICCP has developed extensively and is considered as one of the main 11 principles and methods for the protection and repair of RC structures (British Standards Institution 2008) and covered under international standard ISO BS EN 12696 (British Standards Institution 2012). In the UK, the biggest application of ICCP systems on RC structures is located on the MLMV with over 700 of them already installed (Christodoulou et al. 2013).

Work by Broomfield and Tinnea (1992), Glass and Chadwick (1994), Presuel-Moreno et al. (2002) and Glass et al. (2007) provided evidence that following a period of continuous ICCP application, there is an increase in the tolerance to chloride contamination. The observation that electrochemically treated structures are more tolerant to chloride contamination is countered by an observation that in very heavily chloride-contaminated concrete, corrosion may initiate again.

However, a recent report by the Transportation Research Board, U.S.A. (2009) noted that ICCP is no longer used in many North American States because of disappointing past experience, being more expensive than other options, and because monitoring and maintenance was a significant burden.

With an application history of 25 years on the UK's MLMV, a large number of ICCP systems were reaching the end of their design life, while in many cases failures were also noted due to material deterioration, vandalism, or improper material selection. Under such conditions the protective current is no longer applied and the structure is considered at risk of corrosion. Thus, research on the long-term performance of ICCP systems would be particularly useful for the industry. This developed the basis for *research package 2* of this work. More detailed background information can be found in Appendices C and D.

GCP is an attractive alternative technology to ICCP for arresting and preventing corrosion due to its simplicity. Early known GCP systems were installed on bridge structures in the USA between 1976 and 1980 (Sagues and Powers 1994). In the 1990's various surface applied proprietary systems were developed, and from 1999 discrete anode systems embedded in cavities in the concrete were also introduced to the market. The most widely used systems in the UK are discrete anodes embedded in cavities (NACE 2005, Concrete Society 2009, Christodoulou et al. 2009). This is probably one of the most rapidly developing areas in the field of corrosion management and new products are regularly emerging into the market (Pianca and Schell 2004, Glass et al. 2012, Holmes et al. 2012). However, there are some limitations associated with this technique such as design life and level of protection of the steel reinforcement from corrosion (Dugarte et al. 2007, Sharp and Brown 2007, Brown and Sharp 2008, Christodoulou et al. 2008, Dugarte and Sagüés 2009).

The popularity of GCP technology, with its recent developments but some inherent drawbacks, provided the basis for *research package 3* of this work which concentrated on alternative solutions to improve the corrosion protection provided by GCP. More detailed background information can be found in Appendix E. Hybrid corrosion protection is a combination of a temporary ICCP application and a long term GCP (Holmes et al. 2011, Glass et al. 2012). Research was not undertaken in the field of hybrid CP as this was covered by another EngD programme (Steve Holmes) which was running concurrently to the present one (Holmes et al. 2011, Holmes et al. 2012).

Chloride extraction is a short-term electrochemical technique that involves the passage of a direct current from the surface of the concrete to the reinforcement (Broomfield 2007). It aims to provide service life extension of RC structures by considerably reducing chloride concentrations at the reinforcing bar, which is the main cause for reinforcement corrosion. Due to a number of risks associated with its use and questions from the industry on its long-term effectiveness (Marcotte et al. 1999, Bennett et al. 1993, Siegwart et al. 2005, Ihekweba 1995), chloride extraction has not been extensively used in the UK. As such, no further work was pursued in this field either.

2.1.3 Surface Treatments

In atmospherically-exposed concrete chlorides are transported due to a combination of capillary absorption and diffusion (Kropp and Hilsdorf 1995, Concrete Society 2008). A structure protected from chloride ingress will attain a longer life with a reduced maintenance regime. Surface treatments include the use of drainage systems (i.e. gullies), hydrophobic treatments and surface applied solutions (which diffuse through the concrete pore system to prevent reinforcement corrosion i.e. corrosion inhibitors). Several studies have investigated

the beneficial effects of reducing chloride diffusion in concrete by employing surface treatments (Basheer et al. 1997, Ibrahim et al. 1997, Vries and Polder 1997, Basheer et al. 1998, Almusallam et al. 2003, Yang et al. 2004, Medeiros and Helene 2008). They can be divided into three broad categories – coatings, pore blockers and pore liners.

Pore liners are commonly used for the hydrophobic treatment of RC structures, and in particular for areas that do not receive traffic. The most common pore liners are silanes, a group of silicones containing one silicon atom (Concrete Society 1997). They offer simplicity of application, low material cost and low maintenance requirements. Hydrophobic impregnations are covered under BS EN 1504-9 principles 1, 2, 5 and 8 (British Standards Institution 2008) and the required performance characteristics defined by BS EN 1504-2 (British Standards Institution 2004). Several studies have investigated the beneficial effects in reducing the rate of chloride diffusion in concrete by employing silanes (Basheer et al. 1997, Ibrahim et al. 1997, Vries and Polder 1997, Medeiros and Helene 2008,).

Although there are extensive trials assessing silane performance in reducing water absorption, data on their long-term performance under real environmental conditions is quite scarce. Work by Polder and de Vries (2001) provided preliminary evidence that silanes were still effective even after five years of outdoors environmental exposure. Work undertaken by the Transport Research Laboratory in the UK (Calder and McKenzie 2008) also provided a basis for the durability of silanes by examining specimens extracted from full-scale silane treated structures which have been in service for up to four years. The work by Schueremans et al. (2007) provided long-term performance data up to 12 years.

Based on the above, it was identified that silanes appear to have long-term durability but rigorous empirical evidence from the performance of full-scale RC structures was lacking.

This observation formed the basis for *research package 4* of this work. More detailed background information can be found in Appendix F.

Each of the aforementioned four objectives is brought together under an individual research package. This approach aimed to contribute to more than one corrosion management technique as all of the previously mentioned corrosion management techniques are interconnected and commonly used in conjunction for the repair, rehabilitation and refurbishment of concrete structures. By undertaking research based on full-scale RC structures it aimed to derive directly tangible benefits for the construction industry based on rigorous scientific data.

2.2 AIM

The overarching aim of this research was to obtain empirical data from full-scale RC structures in order to investigate the long-term performance of the most common corrosion management techniques, as identified under the four distinct research packages in section 2.1.

The benefits from this work include establishing a basis for more material efficient designs, extended intervals between planned maintenance of existing systems, reduced monitoring frequencies and alternative monitoring solutions.

2.3 OBJECTIVES

In order to achieve the above aim for each research package, the following specific objectives were identified:

- Objective 1*** Examine the in-situ performance of patch repairs with various proprietary repair products to diagnose the cause and consequences of incipient anode formation.
- Objective 2*** Examine the long-term performance of Impressed Current Cathodic Protection by turning off the protective current in order to identify potential secondary residual protective effects, which could consequently influence design standards and maintenance strategies.
- Objective 3*** Investigate the viability of galvanic anodes installed in parent concrete around the perimeter of the patch repair and assess the influence of the proprietary repair product on their performance.
- Objective 4*** Examine the long-term performance of hydrophobic impregnations, such as silanes, on specimens extracted from full-scale RC structures to establish their residual protective effects and required intervals of re-application.

[This page is left intentionally blank]

3 METHODOLOGY

This section provides a review of the methodological considerations, together with a brief discussion of the main research methods employed. Because the work revolved around four distinct research packages, this chapter provides only the overarching methodological approach. Full details of the testing methods and experimental arrangements for each particular theme are given in the published papers in Appendices B to F.

3.1 METHODOLOGICAL CONSIDERATIONS

This work comprises four distinct research packages, each one with individual and specific objectives, which all together contribute to the overarching aim. The research methods were therefore selected on the requirements of the objectives associated with each research package.

Research overall, is essentially derived from the needs of everyday life. Its purpose is to describe, examine, explain, develop and test ideas, theories or specific problems (Brewer 2007). As such, research classification will be reliant on: i) its purpose, ii) process followed, iii) logic, and iv) outcome (Hussey and Hussey 1997).

Under each of the four main categories above, research may be further classified into further types and processes, summarised in Figure 3.1. It can be observed that a mixture of purposes and processes may be utilised in order to deliver the objectives identified.

Looking at the overarching aim of this work, the focus was on obtaining empirical data from full-scale RC structures. As such, exploratory and analytical approaches will be suitable in order to identify patterns which lead to the formation of hypothesis, measure and analyse data and seek to identify whether specific phenomena are likely to reappear.

A quantitative process was adopted to satisfy the above purposes. It is very common in the field of engineering and physical sciences as it allows rigorous testing of theories, obtaining mathematical data and analysing them in order to confirm the original theory or form an alternative hypothesis (Hussey and Hussey 1997). This resulted in the testing and monitoring of RC structures and specimens extracted from them.

The logic employed is important as it can direct the research in the appropriate processes. It may be deductive (top-down) or inductive (bottom-up) depending on the nature of the problem and the overarching aim of the research (Fellows and Liu 2008). Deductive will start by formulating a hypothesis, undertake some form of testing, and analyse the results, with an aim to accept or reject the original hypothesis. An inductive approach will usually start from a given observation and/or observing trends, which forms a hypothesis, undertake some form of testing, analyse the results and develop a scientifically sound basis of understanding based upon the observations. The overarching aim of this work denoted that both logics will need to be employed in order to meet the objectives identified.

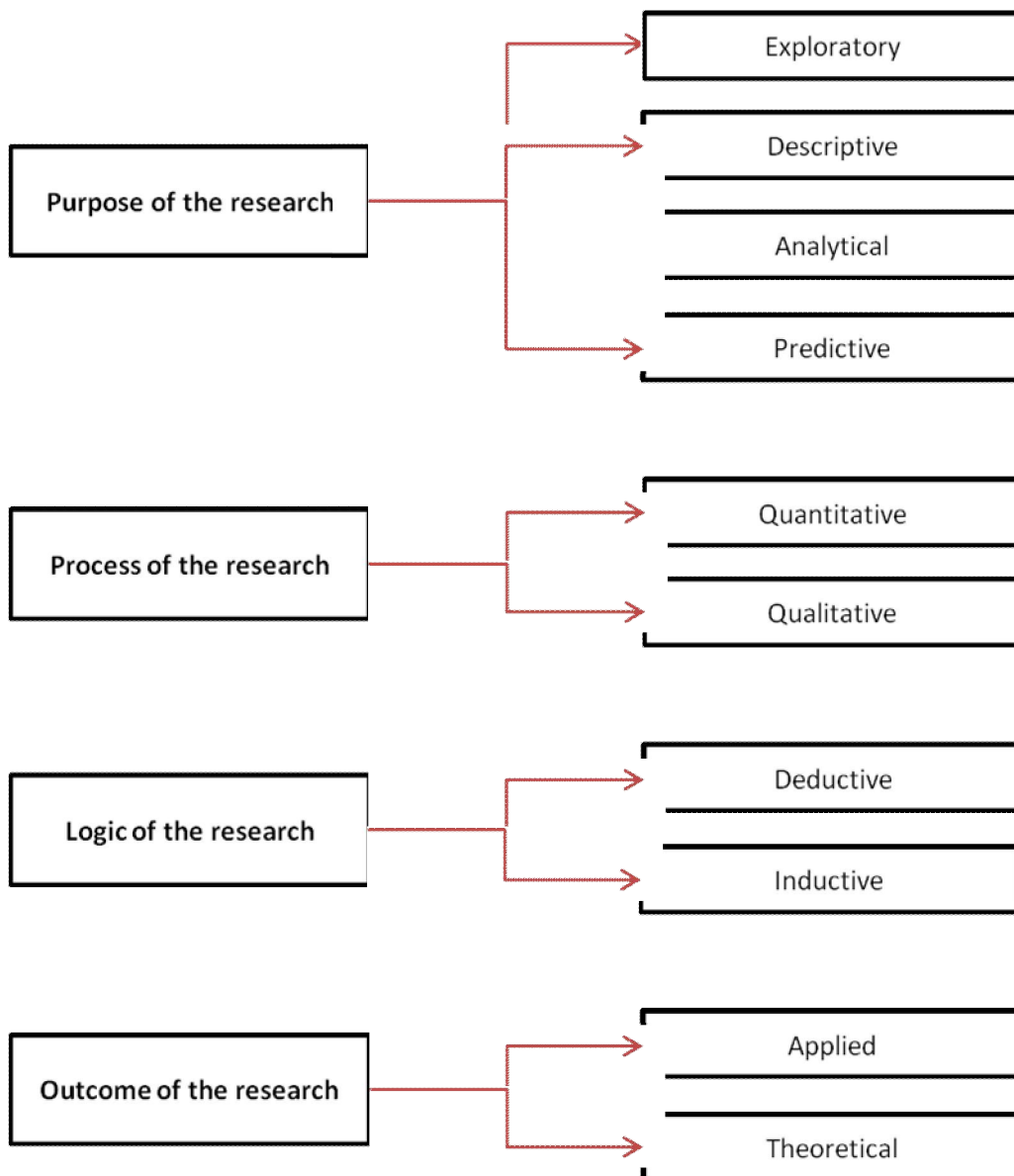

Figure 3.1 Overall classification of research (Brewer 2007).

All of the above will subsequently shape the outcome of the research and whether this will be applied, theoretical or a mixture of both. The purpose, process and logic employed in order to satisfy the requirements of each research package is summarised in Table 3.1.

Table 3.1 Methodological considerations employed for each objective of this work.

	Research Package 1	Research Package 2	Research Package 3	Research Package 4
Purpose	Exploratory and Predictive	Exploratory and Analytical	Analytical	Exploratory and Analytical
Process	Quantitative			
Logic	Deductive	Inductive	Deductive	Inductive
Outcome	Applied and Theoretical	Applied and Theoretical	Applied	Applied

3.2 METHODOLOGY DEVELOPMENT AND REFINEMENT

Having established the research purpose, process and logic for each research package the next step was to develop a structured model. This can be: i) a focus down model based on initial literature review and subsequent analysis; ii) an opening out model based on an initial brief literature review, subsequent analysis with additional literature review; or iii) a hybrid (Dunleavy 2003).

In this work, the opening out model was well suited because an initial brief literature review could be undertaken in order to establish current knowledge and for establishing patterns in the performance of the corrosion management techniques examined. Based on this, structures could be identified for their suitability to undertake the research work, make access arrangements and appropriate monitoring and testing programmes could be established.

Sets of patterns and observations were established following the analysis of the quantitative data collected through testing and monitoring. Based on these, an additional and result-focused literature review was undertaken in order to establish similar reoccurrences in the works of others and the impact of those results on current knowledge.

Conferences and workshops served as a communication platform. This was an opportunity to present the preliminary results of the research, publish papers and gain valuable feedback from fellow researchers and industry leaders. Feedback received was used in order to refine the testing programmes with an aim to address limitations and therefore consolidate the research findings.

Research Package 1 – Concrete repair and replacement is the most common corrosion management strategy for RC structures. However, as discussed in Chapter 2, there is limited evidence derived from full-scale structures to demonstrate the contributing causes for the deterioration observed following RC patch repairs. As such, a deductive logic was employed, by which the existing understanding of incipient anode formation was investigated and tested. A quantitative process was employed by which numerous repairs on two distinct RC structures exposed in different environments were monitored.

Research Package 2 – Impressed Current Cathodic Protection is the most common electrochemical corrosion management strategy for RC structures. Its use and success has been well documented (refer to Chapter 2), however there is little published data on its long-term performance, though some anecdotal industry evidence does exist. Thus, an inductive logic was used to develop observations regarding the performance of ICCP systems and use quantitative processes for testing and monitoring.

Research Package 3 – Galvanic Cathodic Protection is another popular electrochemical corrosion management technique for RC structures, which has increasing popularity due to its simplicity and low capital costs. However, it has certain limitations, and as a result it is not used as frequently as ICCP (refer to Chapter 2). Therefore, a deductive logic was employed by which a hypothesis was formed on the basis that an alternative design of GCP can be more effective than traditional designs. Quantitative processes were then used in order to test the

correctness and feasibility of the hypothesis based on performance monitoring of repairs on full-scale RC structures.

Research Package 4 – Hydrophobic treatments such as silanes help prevent deterioration of RC structures by creating a barrier against the transport of corrosion-inducing species. However, there is scarce evidence on their long-term performance and durability. Using inductive logic it is possible to assess the long-term performance of silane-treated structures. Using quantitative analysis, a representative sample of the population was tested in order to develop a basis for establishing a residual design life of silanes on atmospherically exposed RC structures.

3.3 METHODS

This section summarises the testing methodology adopted for each of the four individual research packages to achieve the required objective and provides reference to the expected outcome and location of background information. These are briefly summarised in Table 3.2 with more details provided below and in the relevant appendices.

Table 3.2 Summary of the testing methods and expected outcomes for each objective of this research.

Research Package	Objective	Testing Methods	Expected Outcome	Notes
1	Examine the in-situ performance of patch repairs with various proprietary repair products to diagnose the cause and consequences of incipient anode formation.	Potential measurements	Indication of macrocell activity or not	also refer to Appendix B
2	Examine the long-term performance of Impressed Current Cathodic Protection by turning off the protective current to identify potential secondary residual protective effects which could consequently influence design standards and maintenance strategies.	Corrosion rates (polarisation resistance) Transient analysis Steel potentials	Assessment of protection and residual persistent protective effects	also refer to Appendices C and D
3	Investigate the viability of galvanic anodes installed in parent concrete around the perimeter of the patch repair and assess the influence of the proprietary repair product to their performance.	Potential measurements	Evaluate the polarisation effects afforded by galvanic anodes	also refer to Appendix E
4	Examine the long-term performance of hydrophobic impregnations, such as silanes, on specimens extracted from full-scale RC structures to establish their residual protective effects and required intervals of re-application.	Sorptivity	Determine rate of water absorption	also refer to Appendix F

Research Package 1 – The performance of patch repairs was assessed by means of concrete surface potential mapping which is a commonly used method for identifying corrosion risk of steel reinforcement (Statful 1957, Elsener 2001, Concrete Society 2004b, ASTM 2009). Potential maps were obtained on a 50 mm square grid to detect macrocell activity. The steel potential was measured against the potential of a portable reference electrode (Ag/AgCl/0.5M

KCl) using a high impedance multi-meter. When a direct steel connection was not possible relative measurements were taken to determine the change in the potential within the concrete as described by Glass et al. (2010). It is noted that the potential measurements were used to identify spatial and time variation as opposed to analysis of absolute values as suggested by ASTM C876 (ASTM 2009).

More details of the testing arrangement used are provided in Appendix B.

Research Package 2 – In order to assess corrosion activity in structures previously protected by ICCP, the protective current was interrupted and the following testing methods were used:

1. Potential measurements, undertaken monthly and in some cases continuously
2. Polarisation resistance to determine of corrosion rates, undertaken monthly
3. Transient analysis to determine corrosion rates, test initiated after the first 6 months of the programme

As described previously, measuring steel potentials against the potentials of a standard reference electrode is a long established technique (Statful 1957, Elsener 2001, Concrete Society 2004b, ASTM 2009). Typical ranges of steel potentials for various conditions against different types of reference electrodes are widely available in the public domain (Elsener 2003, DMRB 1990). In accordance with BA 35/90 (DMRB 1990) values more positive than -200 mV Cu/CuSO₄ (saturated) indicate a low probability of corrosion. Steel potentials can give a good approximation of the corrosion risk of steel but they are affected by various other factors (DMRB 1990).

The calculation of corrosion rates by means of polarisation resistance is a well established method and its applicability has been demonstrated in numerous occasions (Polder et al. 1993,

Andrade and Alonso 2004, Concrete Society 2004b). In general, corrosion rates higher than 1–2 mA/m² would be considered to be significant (Concrete Society 2004b).

Calculation of corrosion rates by means of transient analysis was added later to the testing regime as an alternative to polarisation resistance testing. A brief pulse was applied and the potential shift over a short period of time was recorded. The potential shift achieved and the time of potential decay provide the corrosion rate (Glass et al. 1997).

Full details of the testing arrangement used for measuring corrosion rates by means of polarisation resistance and transient analysis on full-scale RC structures are provided in Appendices C and D.

Research Package 3 – Potential mapping, as described in Objective 1 above, was also used for assessing the performance of galvanic anodes in patch repairs. Project specific details are provided in Appendix E.

Research Package 4 – The transport of chlorides into concrete is governed by a mixed mode of capillary absorption of water and diffusion. Capillarity absorption can be defined as the transport of liquids in porous and non-saturated solids due to surface tension acting in capillaries and without appreciable external pressure (Kropp and Hilsdorf 1995). For short-term contact between the liquid and the porous solid surface, a non-steady-state transport mechanism exists. This resembles conditions encountered on-site by atmospherically–exposed, full-scale concrete structures.

Diffusion can be defined as the transfer of mass by random motion of free molecules or ions in a pore solution resulting in a net flow from regions of higher concentration to regions of lower concentration (Kropp and Hilsdorf 1995, Glass and Buenfeld 2000).

Concrete in contact with a salt solution will become contaminated with chlorides primarily due to capillary absorption rather than diffusion alone (Kropp and Hilsdorf 1995, Ungricht

2004). Absorbed chlorides can continue to penetrate by diffusion but at a significantly lower movement rate. Thus, measuring the rate of water absorption (or sorptivity) can provide useful information on the condition of silane treatments. BS EN 1504-2 (British Standards Institution 2004) provides performance requirements for hydrophobic impregnations.

A procedure for measuring the capillary water absorption of concrete is provided by BS EN 13057 (British Standards Institution 2002). This procedure was also used by the present study with modifications to take into account the different size of available specimens. Full details of the testing arrangement used are provided in Appendix F.

4 THE RESEARCH

This section provides a review of the research undertaken and it is divided into four sub-sections in line with the individual research packages. Appendix A provides a summary of how the publication plan was developed and identifies commonalities between the individual research packages.

4.1 Concrete Repair – Research Package 1 (Appendix B)

As discussed in Chapter 2, the redistribution of anodic and cathodic sites following concrete repair has been associated with future corrosion risk and deterioration (Page and Sergi 2000, Bertolini et al. 2004, Broomfield 2007, Concrete Society 2011, British Standards Institution 2012). However, studies by Chadwick (1993), Morgan (1996) and Cleland et al. (1997) suggested that the interface may have substantial contribution to the onset of corrosion following the patch repair of RC structures.

In order to examine the performance of patch repairs on full-scale RC structures, an experimental programme was established based on a multi-storey car park (MSCP) in the East Midlands and a pre-stressed concrete bridge over an estuary in the Scottish Highlands. The structures were undergoing refurbishment at the time and thus offered the required platform for monitoring a number of patch repairs.

Three proprietary repair materials, labelled A, B and C in this work, were used to restore the concrete profile (Table 4.1). All these materials are widely used in the construction industry and comply with the requirements of BS EN 1504 (British Standards Institution 2005). Materials A and B were produced by the same manufacturer, whereas material C by another. The nature of commercial contracts and their risk allocation require that a contractor uses specialist repair materials conforming to a standard. Further details of these repair materials are provided in Appendix B.

Table 4.1 Repair materials, location applied, and brief description of properties

Material	Structure	Repair location	Properties
A	MSCP	Deck	Portland cement based, flowable, polymer modified, shrinkage compensated micro-concrete.
B	Bridge	Soffits and vertical faces	Portland cement based, polymer modified, shrinkage compensated repair mortar with silica fume.
C	Bridge	Deck	Magnesia-phosphate cement based, non-shrink, repair mortar.

Figure 4.1 shows the change in the potential difference between an area repaired with material A (from the MSCP) and the adjacent parent concrete over a period of up to 246 days. The early age results (15 days) show that the potentials within the patch repair were about 200 mV more negative than the potentials in the parent concrete. This difference reduced with time but the changes were relatively small. After 246 days the potential difference was between 150 and 200 mV. The potentials were measured in a variety of naturally occurring conditions including a very wet day on day 88.

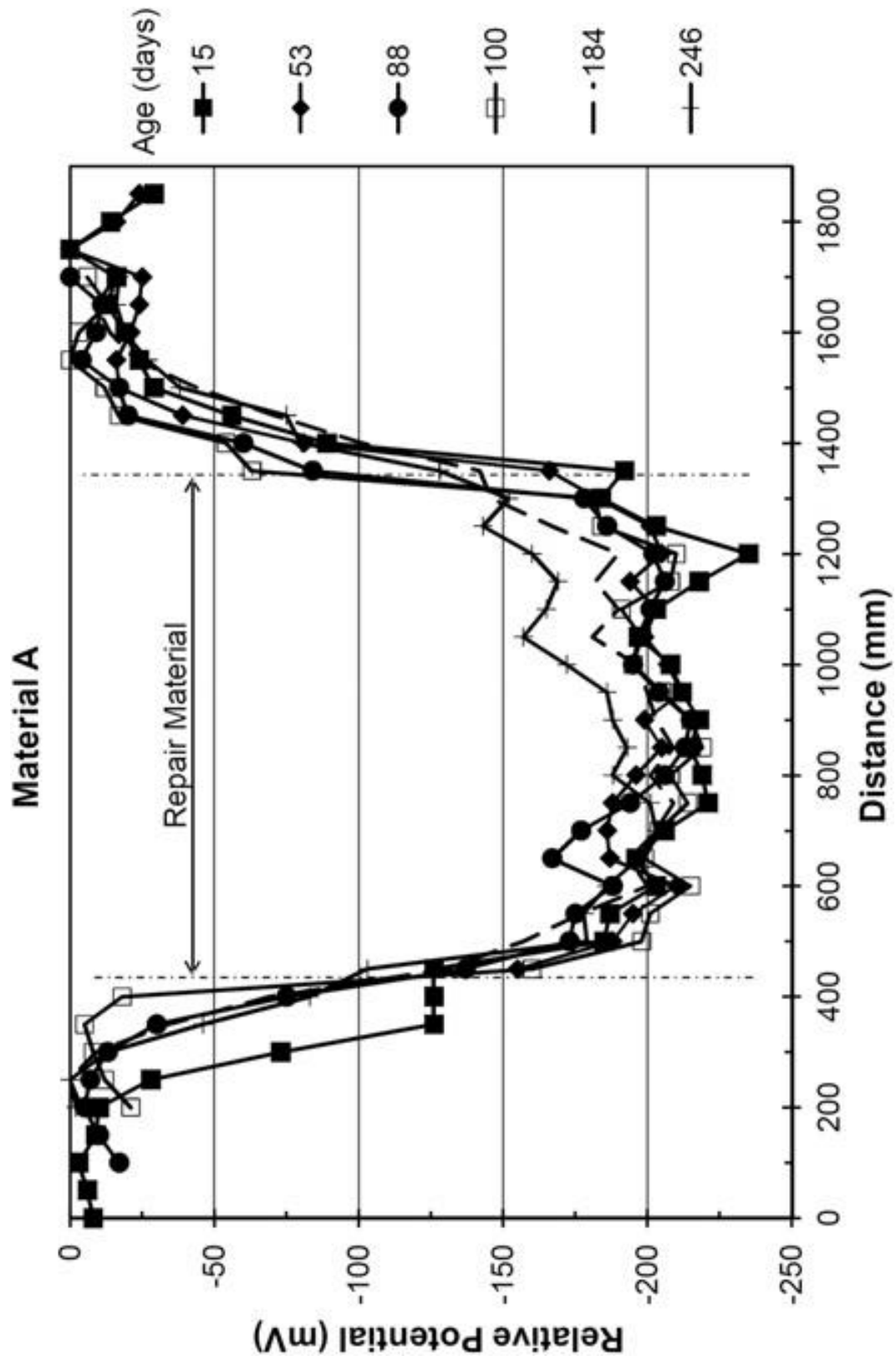

Figure 4.1 Effect of a repair (material A, MSCP) on the relative potential determined at the concrete surface after curing over varying periods of time (Christodoulou et al. 2013).

Data obtained from the patch repairs of the bridge structure illustrated similar behaviour to that obtained from the MSCP. Figure 4.2 shows data obtained at an area repaired with material B. The potentials of the steel within the repair material were about 200 mV more negative than the potentials of the steel in the adjacent parent concrete at the start. After 83 days the change was still greater than 100 mV. In a similar manner, data within the repair area measured before and after repair with material C (Figure 4.3) demonstrated that the potential of the steel within the repair area may be depressed to values that are more negative than the values observed in the parent concrete. The above, were typical and re-occurring findings of the effect of the repair materials on the steel potentials in all cases examined.

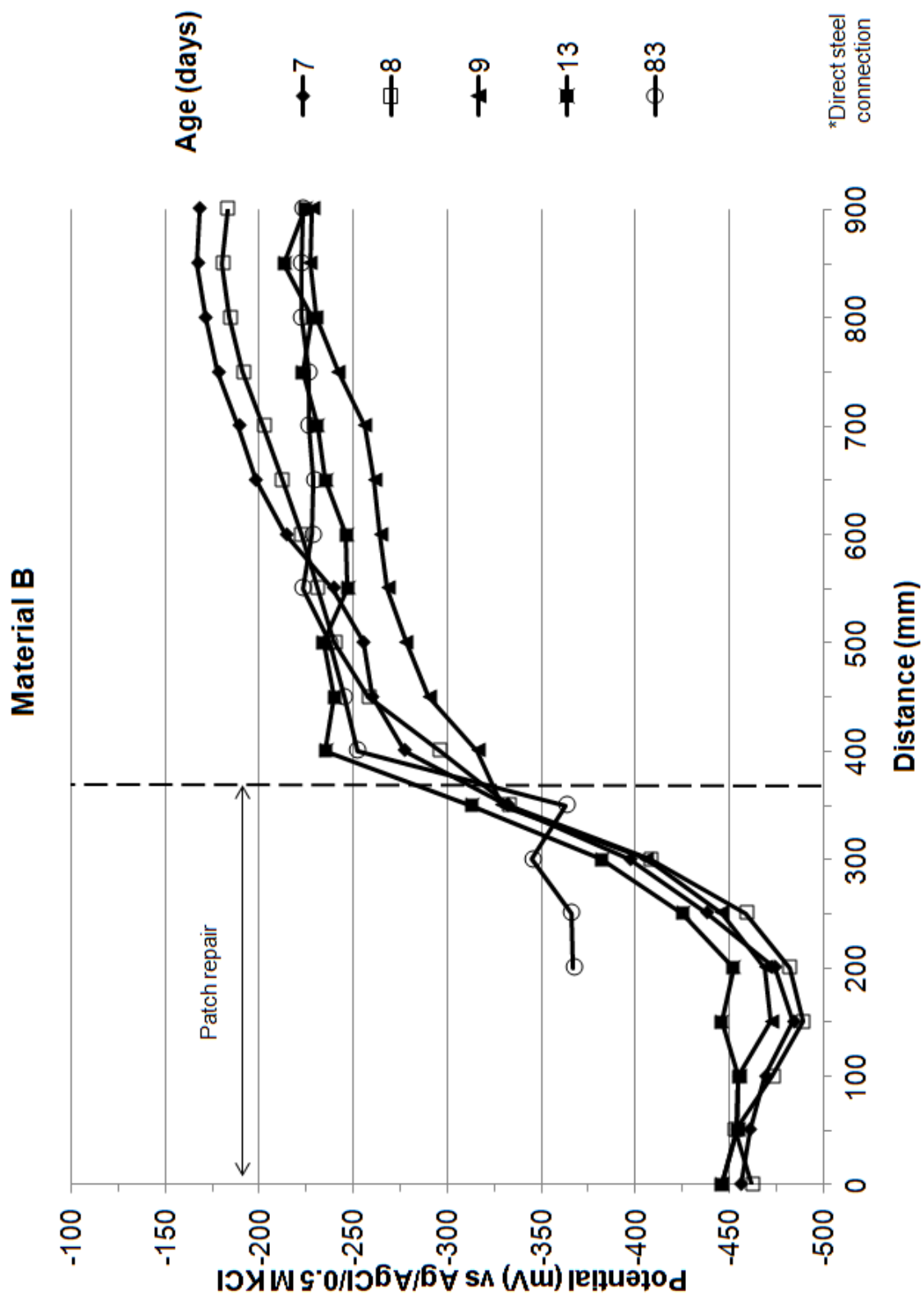

Figure 4.2 Effect of a repair (material B, Bridge) on the steel potentials determined at the concrete surface after curing over varying periods of time (Christodoulou et al. 2013).

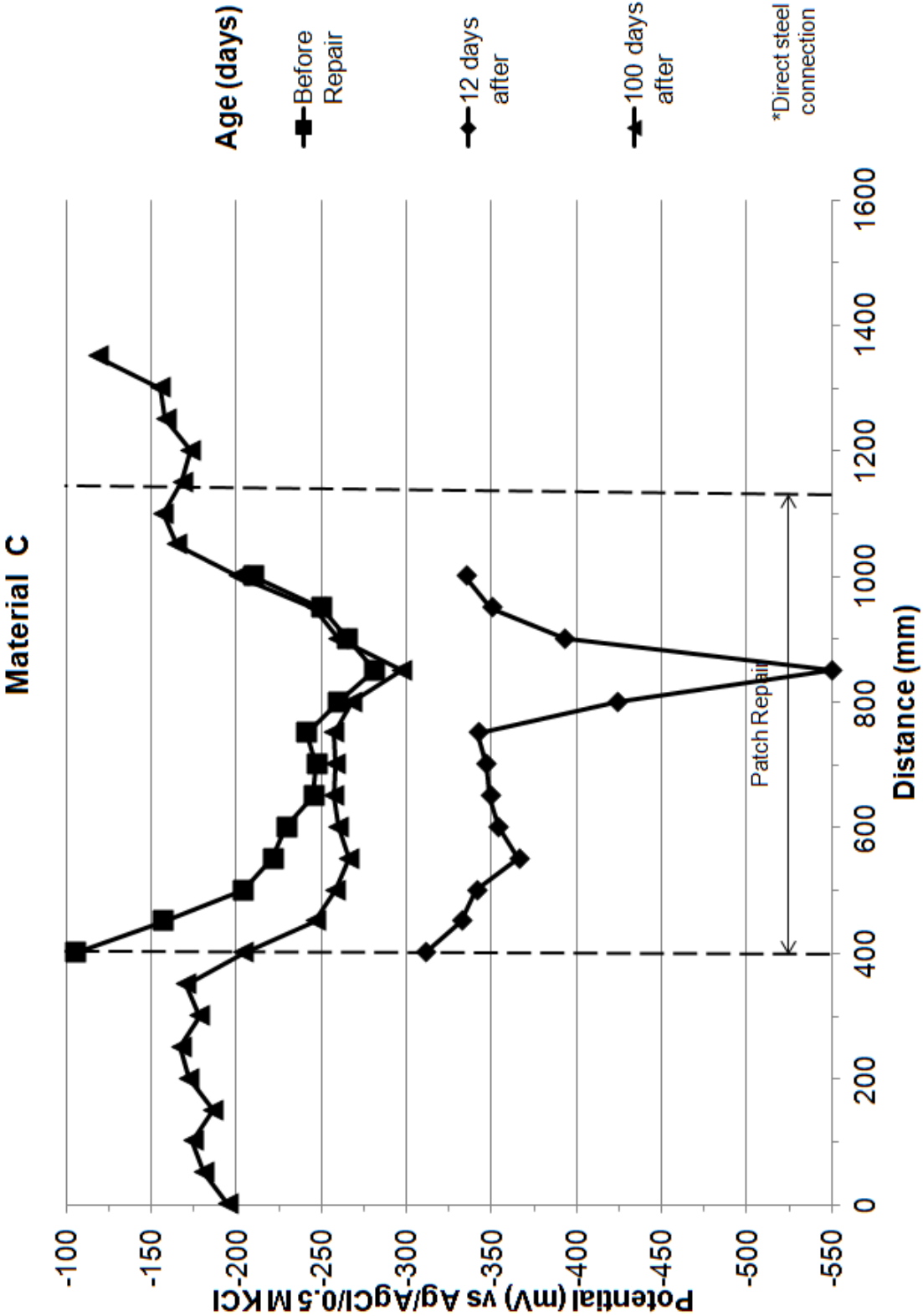

Figure 4.3 Effect of a repair (material C, Bridge) on the steel potentials determined at the concrete surface after curing over varying periods of time (Christodoulou et al. 2013).

Figure 4.4 illustrates three schematic cases of potential changes between parent and repair concrete. Case 1, represents the current understanding of incipient anode formation and is based upon the hypothesis that the steel within the repair area passivates as a result of the alkalinity of the fresh repair material, the absence of chlorides and the abundance of dissolved oxygen in the pore solution of the freshly mixed concrete or repair mortar. As a result the steel potential in the repair rises above the passive steel potential in the parent concrete resulting in a macrocell that induces corrosion (Page and Sergi 2000, Broomfield 2007, Bertolini et al. 2004). However, this hypothesis does not fit with the measurements recorded within this study.

Case 2, represents previously published laboratory data by Page and Sergi (2000) where the repair results in the removal of the corrosion site that used to be an anode. The results are based on testing of a concrete slab cast and repaired under laboratory conditions. The parent concrete was not aged in the same way that concrete on full-scale structures is aged and did not use a proprietary repair material conforming to existing standards for the repair. However, the data presented by Page and Sergi (2000) suggests that although the anodic area was cut out and repaired, the parent concrete still had a residual chloride content which was sufficient on its own to cause corrosion on at least one of the identified areas of incipient anode formation.

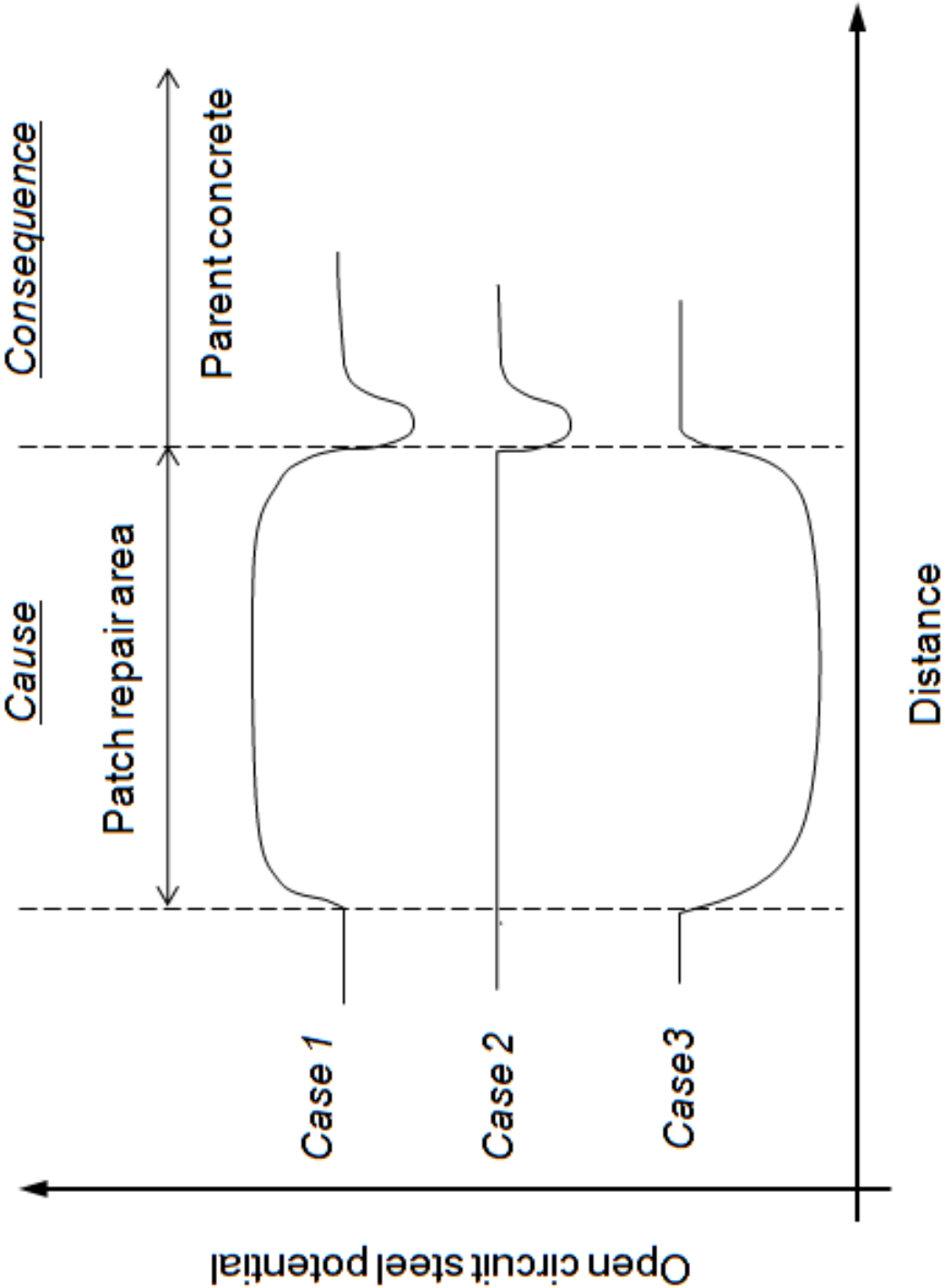

Figure 4.4 Three schematic cases showing potential changes between parent and repair concrete (Christodoulou et al. 2013).

It is generally suggested that a concrete repair will remove the corroding anodic site and as such stop any natural cathodic protection that may have been provided previously to the adjacent steel. However, the benefit provided by cathodic protection delivered from a corroding steel anode in concrete is questionable because corrosion of a steel anode results in expansive products that cause disruption to the surrounding concrete (Glass et al. 2008, Lau and Sagues 2009, Zhao et al. 2012). Thus, it is likely that a corroding steel anode causes more damage than it prevents and the removal of such an anode in the repair process should, in theory, slow the deterioration process if the deterioration was dominated by macrocell activity.

Similar observations have been made with reference to the influence of a macrocell caused by coupling stainless steel to carbon steel in concrete. The impact of a stainless steel/carbon steel couple on inducing corrosion on the carbon steel has been reported to be no different to that of a passive carbon steel/carbon steel couple and did not increase the corrosion damage reported on the carbon steel (Bertolini et al. 1998, Abreu et al. 2002, Qian et al. 2006). Using a similar approach, it is unlikely that a macrocell formed by coupling the steel in the repair area to steel in the parent concrete will have any substantial impact on inducing additional corrosion on the steel in the parent concrete.

Case 3 in Figure 4.4 represents the findings of the current research on two full-scale RC structures, after patch repairs with three different proprietary materials. The potential of the steel within the patch repairs was always more negative than the potential of the steel in the parent concrete over the period of time tested. While the measurements were obtained on real structures made with different concretes repaired using different proprietary repair materials that were exposed to a variety of environmental conditions and subject to many other

unknown variables associated with repair contracts, there was not a single instance where the potential within the repaired area rose to, or above, that in the parent concrete.

An important but often overlooked contributing factor for corrosion initiation is the presence of cracks. Crack formation in RC structures and its relationship to corrosion has been established by a number of studies (Raupach 1996, Concrete Society 2004a, Concrete Society 2010).

Cracks may occur at the interface between the parent concrete and the repair material following patch repair. The presence of such cracks can be attributed to drying, plastic shrinkage, thermal or stiffness incompatibility, poor curing, surface preparation or a combination of the above (Concrete Society 2010).

In some areas repaired with the pourable materials A and C, cracks were observed at the visible interface between the parent concrete and the repair material. The full extent of a crack is usually concealed due to the trowel finish of the repair that extends over to the parent concrete. It was only uncovered following surface preparation by mechanically shot-blasting in preparation for an applied coating. For the spray applied material B, no cracks were identified.

In addition, breakout of concrete has also been associated with crack initiation in what has been termed “micro-bruising” (Morgan 1996, American Concrete Institute 2011). Removal of concrete entails various impact and dynamic loads, and depending on the method used and quality of the concrete being removed, it may result in micro-cracking at the repair interface. It was observed that the cracks identified for pourable materials A and C were at all times in repair areas involving mechanical breakout. Spray applied material B was only used in repair areas involving hydro-demolition and no cracks were observed following its application.

Such cracks and interfacial defects between parent concrete and repair material will provide an easier path for chlorides to penetrate into the substrate. The parent concrete may have a higher permeability than the new repair material and this will aid the diffusion process from the interface into the parent concrete. The parent concrete is also likely to have some residual chloride contamination that may promote corrosion. Such defects increase the corrosion risk by lowering the chloride threshold level (Glass et al. 2007). This is also supported by the works of Chadwick (1993) and Morgan (1996).

All of the above support the hypothesis that, on balance, macrocell activity is a consequence, not a cause, of incipient anode formation in repaired concrete structures. Incipient anodes may form around patch repairs and their presence can be detected with potential mapping. Alternative causes of incipient anodes include a permeable interface between parent concrete and repair material, residual chloride contamination of the parent concrete and damage to the steel-concrete during concrete removal. The findings have an impact on the current industry practice regarding concrete repairs provided by BS EN 1504-9 (British Standards Institution 2008). The effects of interfacial defects, surface preparation, age and composition of parent concrete and residual chloride content should be taken into consideration and assessed prior to any concrete repair scheme.

One of the limitations of the current work is that data was collected for a period of up to 246 days. Further monitoring of the repairs was not possible as access was removed in the case of the bridge structure and the repairs were covered with a proprietary waterproofing in the case of the MSCP. However, the data set has been sufficient to demonstrate that macrocells did not develop immediately after the repair process as was commonly considered previously.

The work was also limited to the performance of two distinct structures with different parent concretes, for which historical information was limited. Future research work could be established to investigate such effects in structures where the concrete mix design is known.

4.2 Impressed Current Cathodic Protection – Research Package 2 (Appendices C and D)

ICCP is generally regarded as the only solution that can directly stop corrosion even in the most corrosive environment (Transportation Research Board 2009). In the UK, the biggest application of ICCP systems on RC structures, with over 700 installed is on the MLMV (Christodoulou et al. 2013). However, the recent report by the Transportation Research Board, U.S.A. (2009) noted that ICCP is no longer used in many U.S. states because of disappointing past experience, being more expensive than other options, and because monitoring and maintenance was a significant burden.

In the UK, ICCP has had several successful applications; primarily on the MLMV. The first operational ICCP repair contract was installed and commissioned by July 1991, and utilised a conductive coating impressed current anode system. This particular anode system is still operational today. Since then it is estimated that ICCP has been installed on 740 crossbeams of the MLMV and more than 100,000 m² of concrete surface area have been protected (Christodoulou et al.2013).

However, there is evidence from industry practice in the UK that the capital cost of ICCP, its technical complexity and its maintenance requirements results in project risks for maintenance agencies, making ICCP less favourable. In addition, with a large number of RC structures currently protected by ICCP now reaching the end of their design life, or in cases failing to meet the design life due to material deterioration, vandalism or improper material selection,

these are queries regarding the subsequent corrosion risk of these structures (Christodoulou et al 2013).

For this work, 10 full-scale RC structures, which had been previously protected by ICCP, were selected based on the age of the system, accessibility and residual chloride contamination (Table 4.2). Figure 4.5, illustrates a typical arrangement of the sub-structure for the MLMV. Each span of the viaduct is simply supported on a reinforced concrete crossbeam. In total there are approximately 1200 crossbeams in the network and about 740 of them have been protected by means of ICCP over the last 25 years.

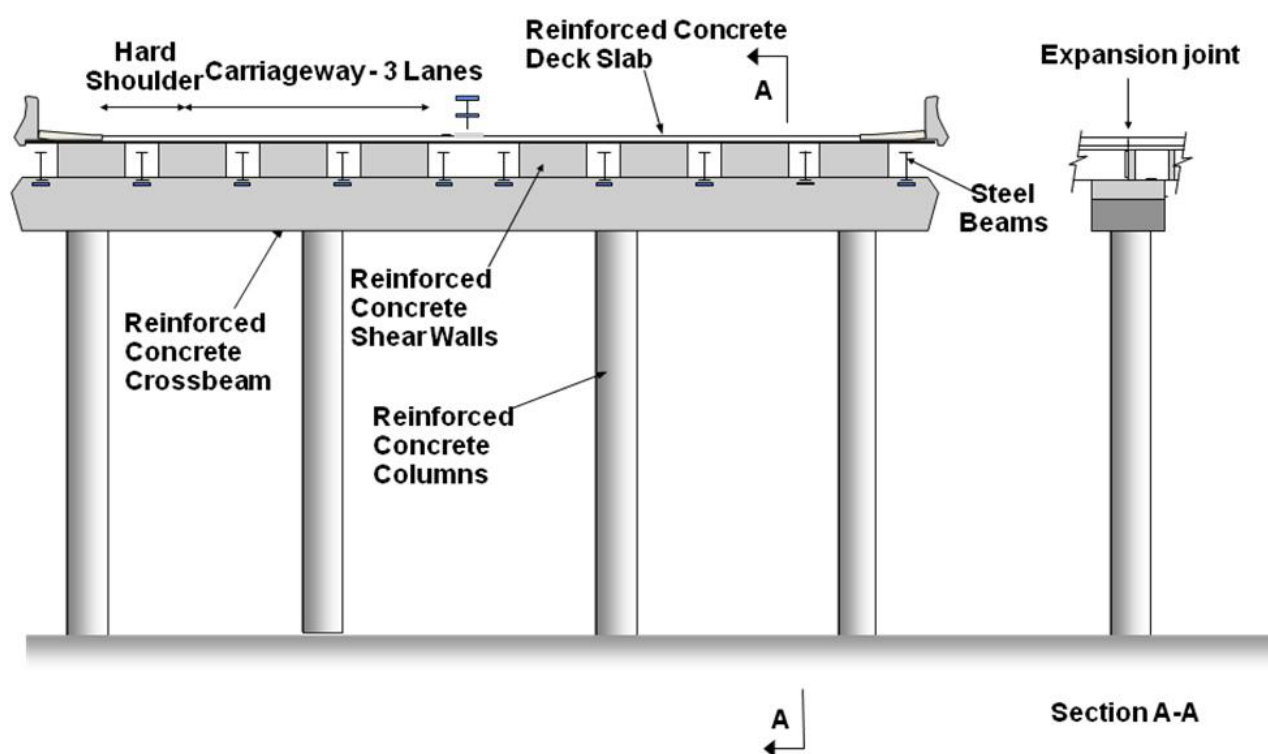

Figure 4.5 Typical sub-structure arrangement of the MLMV

The protective current provided by the ICCP system was intentionally interrupted for a period of at least 33 months and monitored for corrosion initiation. Additional details on structure selection, materials and testing methods are provided in Appendix C.

The beams tested were selected in such an order as to represent reinforced concrete with a high risk of chloride-induced corrosion that had been subject to cathodic protection for a range of protection periods. A total of 10 beams were selected based on the age of the installed ICCP system, accessibility and chloride levels indicating a residual corrosion risk. On every beam two locations were selected for monitoring based on the chloride analysis. Chloride samples were taken at random locations across the full extent of the crossbeams and always in parent concrete.

Table 4.2 Details of the 10 selected structures

Structure Reference	Year of Installation	Sampling locations with Cl ⁻ greater than 1% by weight of cement	No of Cl ⁻ sampling locations	Sampling locations with Cl ⁻ greater than 0.4% by weight of cement	Age of system (as of 2007) (years)
A1	1991	2	4	4	12-16
A2	1995	2	5	3	
A3	1995	2	5	5	
B1	1996	3	6	4	9-11
B2	1998	1	5	4	
B3	1998	2	5	3	
B4	1998	2	5	3	
C1	1999	0	5	2	5-8
C2	2002	0	5	1	
C3	2000	0	5	1	

Monitoring of the steel potentials demonstrated that the values recorded during this study were in most cases more positive than -120 mV (Ag/AgCl/0.5 M KCl) and therefore the corrosion risk was currently negligible on these structures, even after 33 months without ICCP (Figure 4.6). The highs and lows observed are usually dependent on the weather

conditions. Although the ambient conditions were not recorded as part of this study, the site notes indicate that in the majority of the occurrences parts of the crossbeam were very wet whereas other were completely dry. The absence of a trend to more negative values indicates that the passive condition is stable.

Structure B4 exhibited a different response than the other structures, which could have suggested that corrosion was occurring. However, corrosion rates both from polarisation resistance and transient response analysis indicated that the steel was passive. This reinforced the view that open circuit steel potentials should be used only for guidance on overall corrosion risk and not to interpret absolute values which are subject to a great degree of variation.

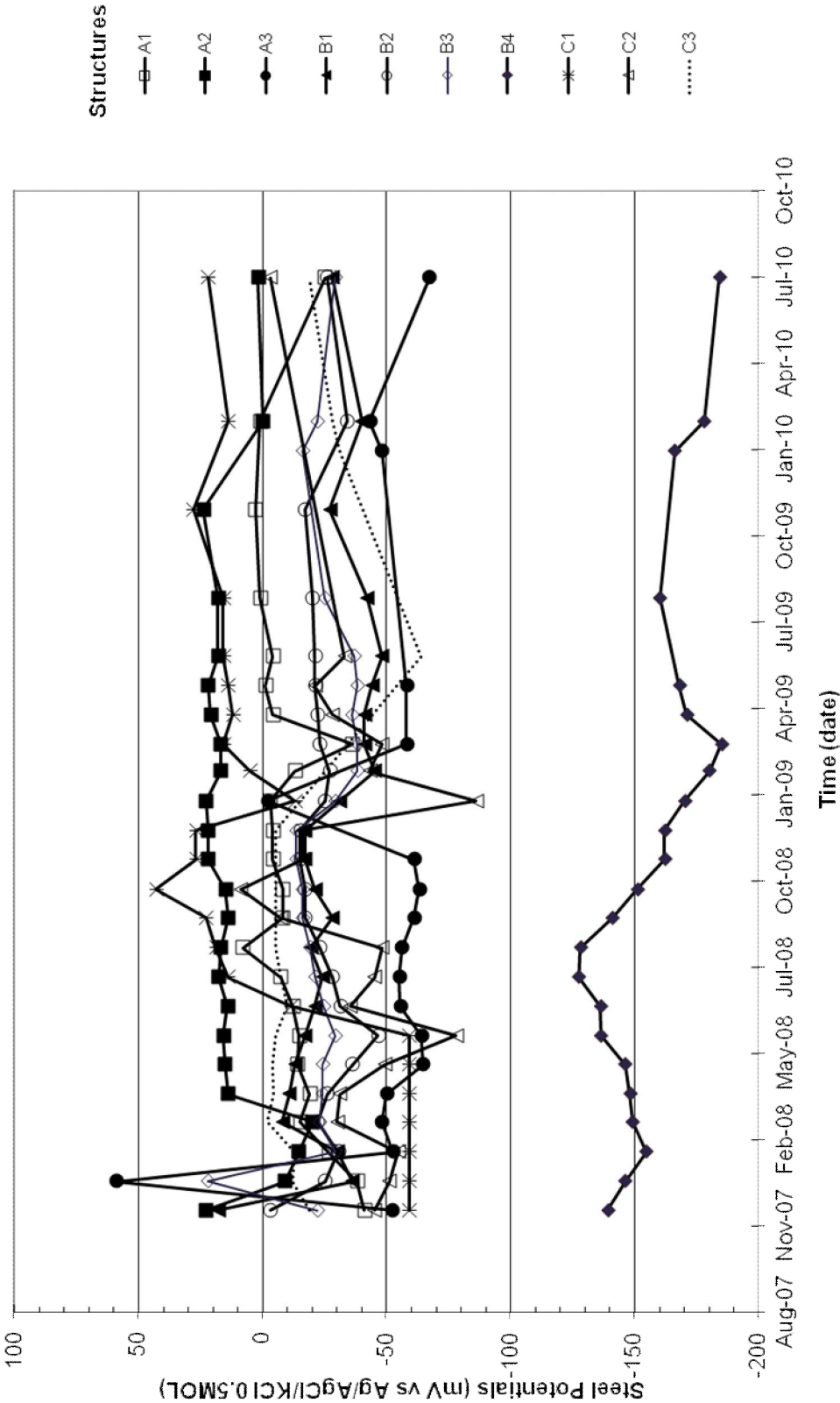

Figure 4.6 Steel potentials of the 10 structures monitored over a period of 33 months (Christodoulou et al. 2010).

Corrosion rate measurements based on polarisation resistance testing over a period of 33 months are shown in Figure 4.7. It can be observed that in all cases the corrosion rates were well below the threshold level of 2 mA/m^2 (Concrete Society 2004b), reinforcing the view that ICCP may have persistent long-term beneficial effects. Occasionally, peaks of higher corrosion activity can be observed. These are primarily associated with galvanic currents during wet weather conditions when parts of the structures are wet whereas others remained dry. Overall, there was no trend of increasing corrosion rates after 33 months of no protection.

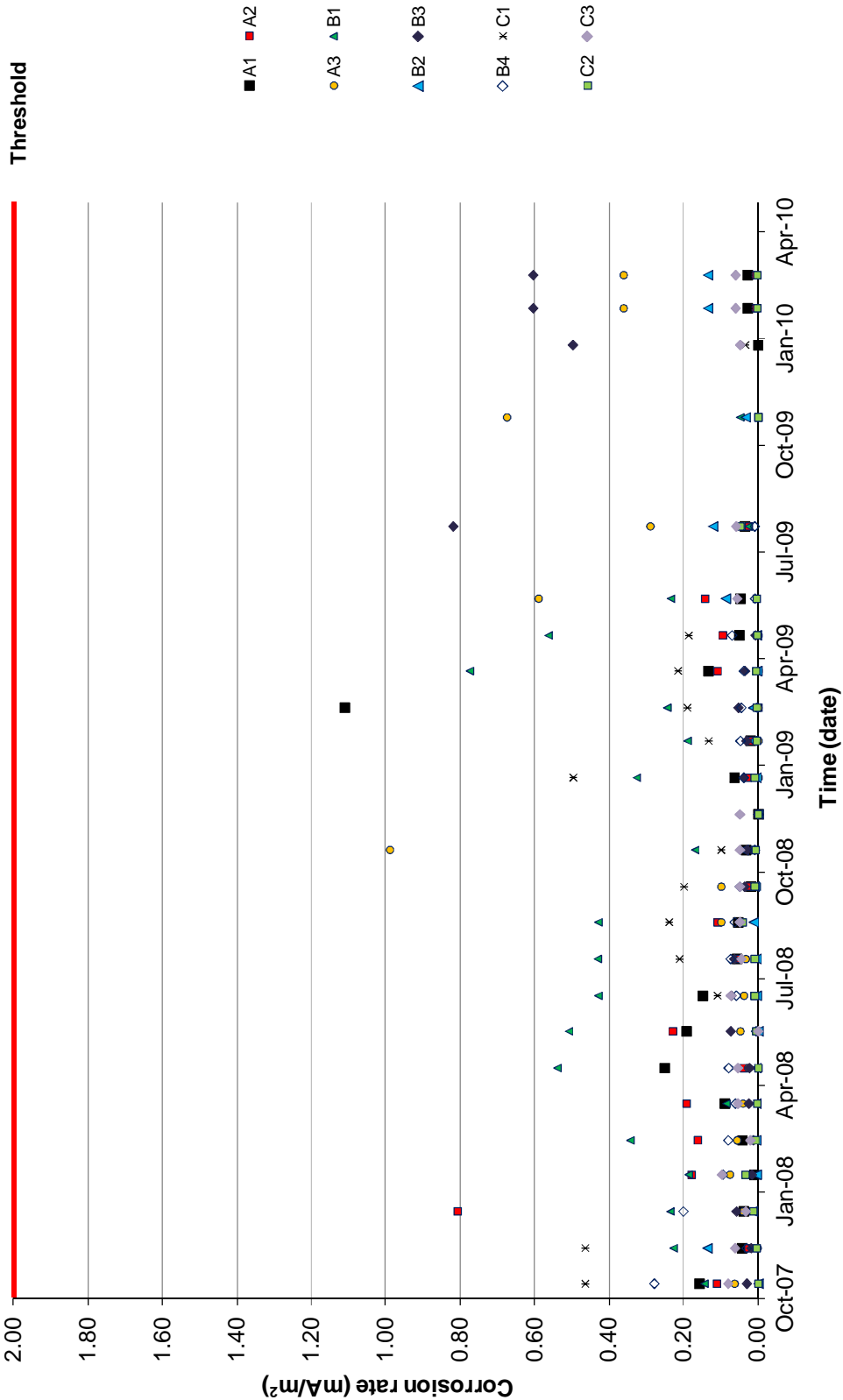

Figure 4.7 Corrosion rates summary from polarisation resistance testing over a period of 33 months (Christodoulou et al. 2010).

The third method of testing to evaluate the corrosion risk on the structures under investigation was transient response analysis. It provides useful information concerning the steel-concrete interface. Such an approach is particularly preferable for very low frequencies such as those of steel in concrete (Glass 1995, Andrade and Alonso 1996, Glass et al. 1997, Glass et al. 1998). It overcomes the complexity of the frequency response analysis and simplifies it for use on site. Transient analysis is effectively the analysis of the response of an electrode after the application of a brief pulse. Detailed information on the testing arrangement used to measure and interpret transient data is provided in Appendix D.

A typical plot of the resulting transient analysis is provided in Figure 4.8. The units on the axes are derived by dividing the potential by the current density. In addition, they are the same units as for polarisation resistance. The point at a phase angle of zero (the x-axis intercept) is the polarisation resistance. As such, corrosion rates can also be calculated. The frequency at the peak of the curve is termed the characteristic frequency (f). It is affected by the condition of the steel and lower frequencies indicate a more intact passive film.

When comparing the data of Figure 4.8 with published laboratory data for active and passive steel (Glass et al. 1997, Glass et al. 1998) it can be determined that the site data corresponds closely to data obtained from passive steel specimens. This is indicated by both the x-axis range and the characteristic frequency.

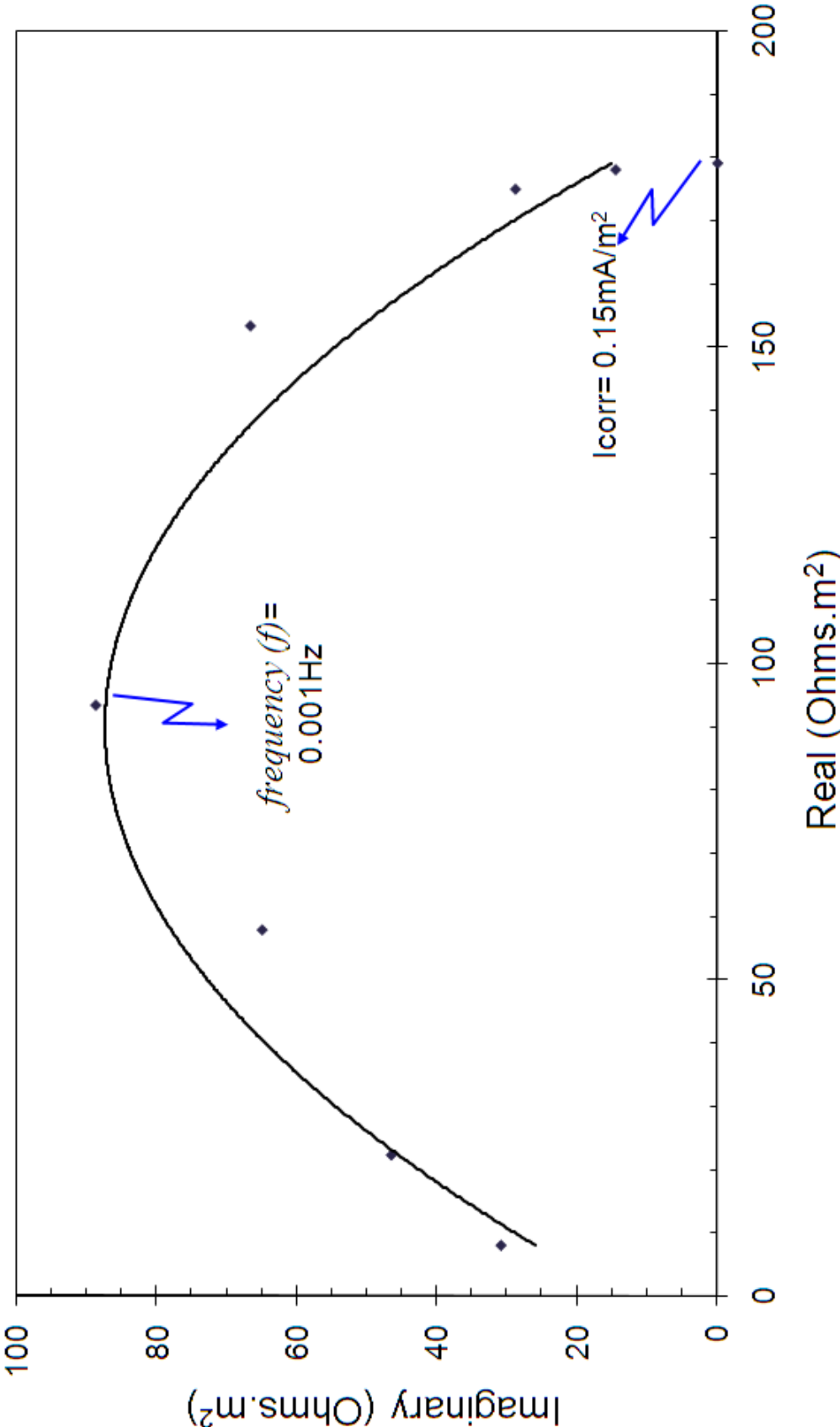

Figure 4.8 Typical impedance plot arising following analysis of transient data (Christodoulou et al. 2010).

From the raw data, an equivalent corrosion rate can also be derived which can be used for comparison with corrosion rates derived from polarisation resistance testing. Figure 4.9 provides a summary of corrosion rates based on transient analysis over a period of 33 months without corrosion protection. It can be observed that in all cases examined the corrosion rates were well below the threshold level of 2 mA/m^2 (Concrete Society 2004b). The occasional peaks of higher corrosion activity can be associated with galvanic currents during wet weather conditions when parts of the structures are wet whereas others remain dry. Overall, there was no trend of increasing corrosion rates after 33 months of no protection.

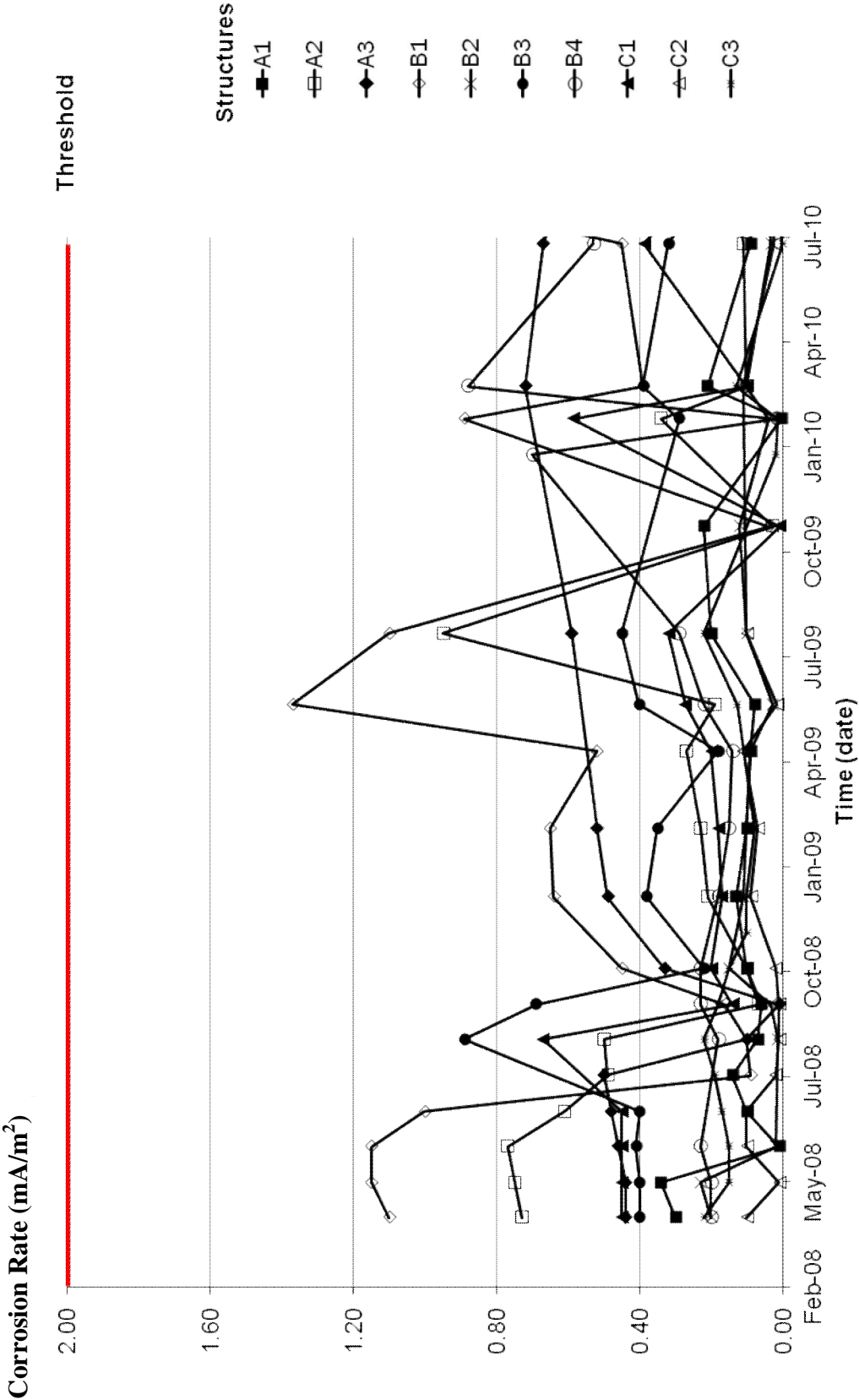

Figure 4.9 Corrosion rates summary from transient analysis testing over a period of 33 months (Christodoulou et al. 2010).

By comparing Figures 4.7 and 4.9 it can be observed that in general, polarisation resistance returned more frequently very low corrosion rates as opposed to transient response analysis. This indicates the possibility that polarisation resistance may under-estimate the corrosion current densities or transient response analysis may over-estimate them. The differences observed may be explained by the size of the data set, polarisation resistance effects and the length of perturbation.

Polarisation resistance measurements are obtained while current is applied, whereas for transient response analysis all the data are collected after the current perturbation has been applied and as such they do not include the effects of the resistance of the concrete. Therefore, corrosion current densities through polarisation resistance analysis have to be compensated for the effects of concrete resistance. Furthermore, the perturbation applied during polarisation resistance is over a greater time and of higher average magnitude than the perturbation for the transient response analysis, which also might affect the results.

On the whole, a number of the structures investigated had high levels of residual chlorides which represented a substantial corrosion risk. Although the structures examined did not receive any protective current for a period of at least 33 months, steel potentials have shifted towards more positive values and have remained passive; and, corrosion rates by means of polarisation resistance and transient analysis have been very low and at all times below the threshold. The results suggest that long term-application of ICCP renders the steel passive and has a persistent protective effect even after the protection is interrupted. In addition, transient analysis of full-scale RC structures was successfully used on site. It provided valuable information about the steel-concrete interface and provided a direct comparison for corrosion rates derived by means of polarisation resistance.

Furthermore, the current suggestion for the protective design current ranges from 5 to 20 mA/m² of steel (British Standards Institution 2012). The ICCP systems examined in this research work were never capable of delivering a current density more than 20 mA/m² at the concrete face. With the ratio of steel to concrete surface area ranging at 1.4:1 – 2:1, it suggests that the maximum possible current density of these systems was limited to approximately 10 mA/m² of steel. Inspection of the monitoring records indicated that on several occasions the power supplies of the anode systems were voltage limited at current densities less than 2 mA/m² of concrete surface area. This suggests that lower design currents may be used and the absence of corrosion should be taken into consideration prior to the development of maintenance and replacement plans.

It also needs to be noted that originally, the ICCP systems installed on the MLMV were designed for a service life of 10 years in order to arrest corrosion activity and assist with asset prioritisation and subsequent maintenance. From the ICCP systems examined as part of this work, structure references type A and B had surpassed the 10 year design life and apart from one instance, all of them were still functioning at the time of testing.

The limitation of this research package may be associated with the sample of structures examined. As discussed earlier, presently there are approximately 700 structures protected by ICCP with 10 of them selected for the sample analysis. The effects identified on these 10 structures were consistent which gives a high level of confidence that they will be applicable to the other structures within the MLMV. However, it needs to be recognised that due to the variable nature of concrete, differences in age of construction of the structures, exposure conditions and maintenance there may be differences in the long-term performance of ICCP systems. These variables were not explored in detail during this study. Furthermore, the ICCP systems examined were installed on bridge sub-structures and as such not necessarily exposed

to water spray carrying chlorides from vehicular traffic. The degree of actual chloride exposure for each structure following installation of the ICCP system was unknown. Thus, in RC structures which will be exposed to chlorides this passive condition of the reinforcement may not be sustained for such a long time and corrosion may initiate in the absence of ICCP protection.

The findings of this research should not be used as a basis for the turning off of ICCP systems with an aim of extending the life of anodes or power supplies. The findings aim to highlight that ICCP does not only provides protection by means of a negative potential shift but it has additional protective effects that should be taken under consideration.

4.3 Galvanic Anodes – Research Package 3 (Appendix E)

Galvanic anodes are used routinely to limit the extent of concrete replacement and extend the service life of patch repairs to RC structures (NACE 2005, Concrete Society 2011, Christodoulou et al. 2011). However, they have certain limitations which affect their performance, summarised in Table 4.3

Table 4.3 Factors affecting the performance of galvanic anode systems applied to RC structures (Christodoulou et al. 2008).

Factor	Effect
Concrete Resistivity	An increase in concrete resistivity reduces the protection current output of a galvanic anode which limits the protection delivered.
Current distribution	Discrete anodes distribute current poorly compared to surface applied anodes but protection can be targeted to the area of need.
Continuing corrosion	Products designed for use in a preventative role may fail when trying to arrest an active corrosion process.
Charge capacity / current output	The maximum theoretical life cannot exceed a period determined by the anode charge capacity and anode current output.
Anode activity / surface area	Determines protection current output and discrete anodes in particular need a method of anode activation. For alkali activated systems, anode activation is dependent on the quantity of alkali in

	the assembly.
Anode delamination / adhesion to concrete	Galvanic anode systems applied to concrete surfaces in particular are at risk of suffering from delamination and loss of contact with the concrete.

This work tested a new arrangement for the installation of galvanic anodes on a MSCP and a bridge structure (refer to Figures 4.10 and 4.11). Both structures suffered from extensive chloride-induced deterioration. Their refurbishment incorporated concrete repairs together with the installation of discrete galvanic anodes.

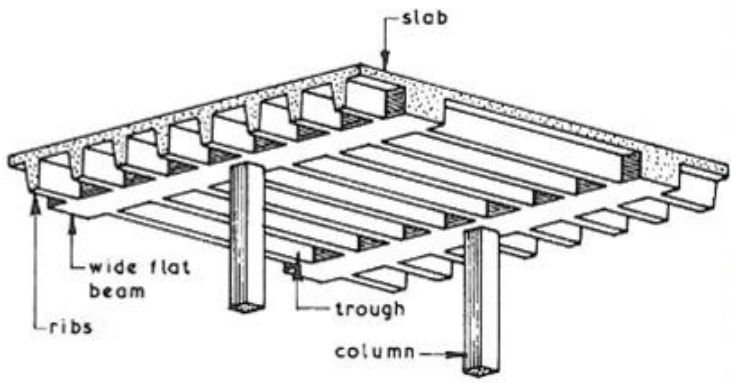

Figure 4.10 MSCP structural arrangement

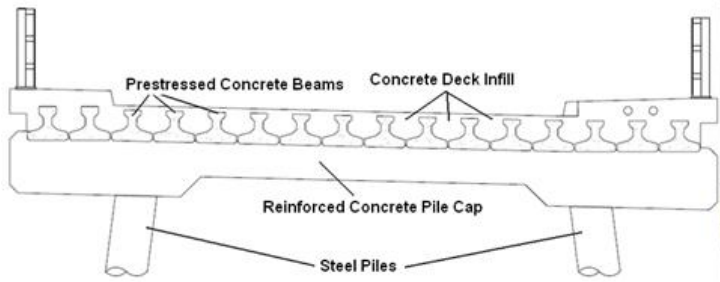

Figure 4.11 Bridge structural arrangement

Galvanic anodes with a diameter of 20 mm and length of 40 mm, containing approximately 65 grams of zinc, were installed in pre-drilled holes of 25 mm diameter and length of 45 mm in the parent concrete as close as practically possible to the edge of the patch and filled with

proprietary material. A titanium wire integrated with the galvanic anodes was connected to the steel reinforcement within the repair area.

Two proprietary repair materials labelled A and B and certified as class R4 structural repair mortars in accordance with BS EN 1504-3 (Concrete Society 2009, British Standards Institution 2011) were selected to restore the concrete profile. The nature of commercial contracts and their risk allocation require that a contractor uses specialist repair materials conforming to a standard. Table 4.4 provides a summary where each material was used.

Table 4.4 Repair materials, location used and brief description of properties

Material	Structure type	Repair location	Application method
A	MSCP	Deck	Poured and trowel finished
B	Bridge	Soffits and vertical faces	Hand or spray applied and trowel finished

This new arrangement aimed to reduce limitations on the performance of galvanic anodes arising primarily from the resistivity of the repair material. The performance of the galvanic anodes was monitored by means of close-interval potential mapping. Full details of the structures, repair materials and testing methodology used in this work are provided in Appendix E.

The typical polarisation effects afforded by the anodes at a distance away from the edge of the patch repair in the MSCP with material type A, over a period of 215 days following installation are shown in Figure 4.12. It can be observed that the anodes affected the steel potentials to a distance of approximately 500 mm away from the edge of the repair after 215 days. The time dependent trends observed in Figure 4.12 can be attributed to changes in the weather conditions.

The trends shown in Figure 4.12 are typical for all the cases examined and recurring findings on the polarisation effect of the anodes at a distance from the edge of a patch repair in the

MSCP with material type A. The exact polarisation distance varied between 500 mm and 600 mm depending on the age of the anodes and the prevailing environmental conditions at the time of testing. No readings could be obtained for longer than 215 days as thereafter the slabs of the MSCP received a surface applied waterproofing.

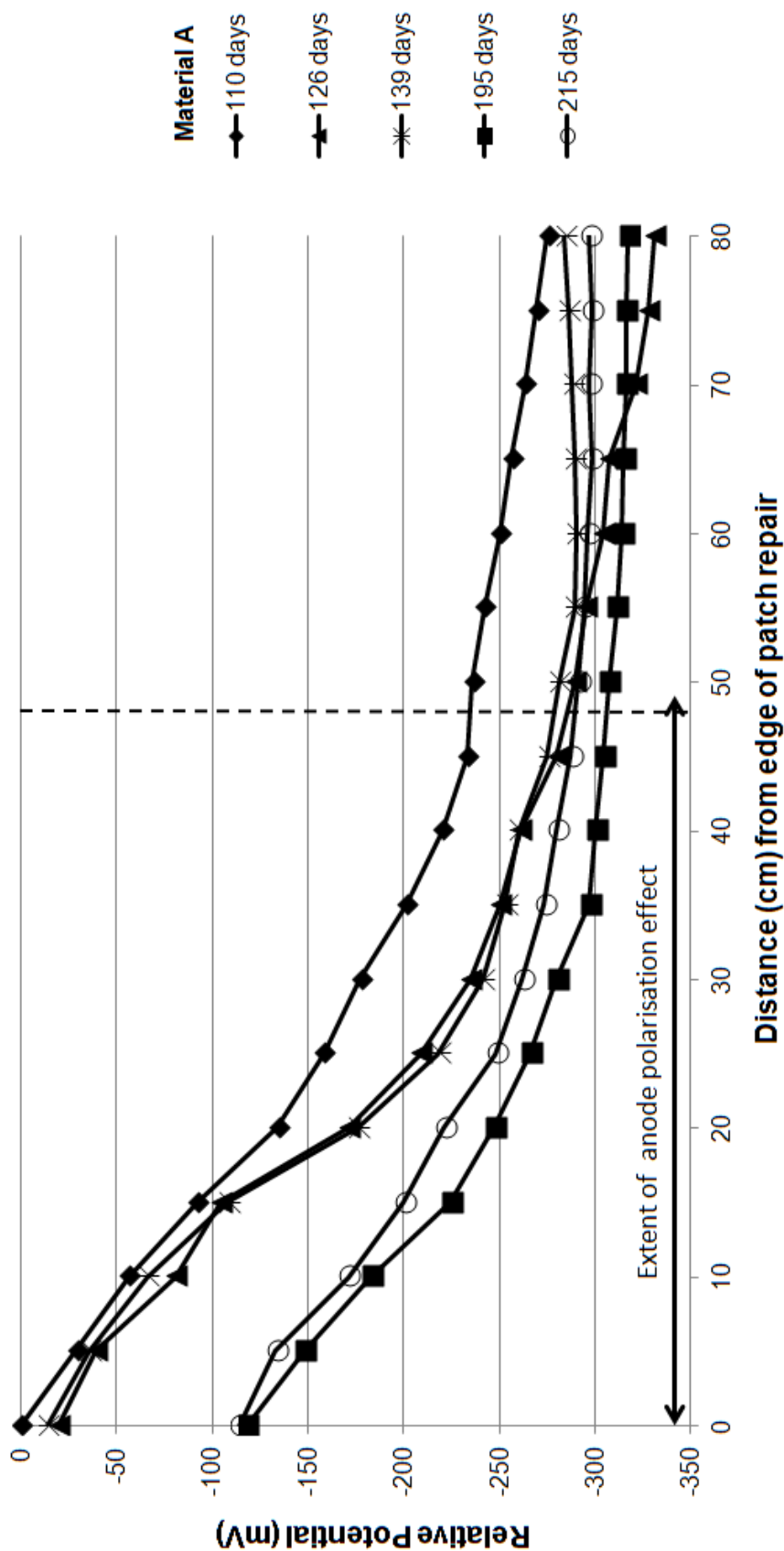

Figure 4.12 Polarisation effect of the anodes at a distance from the edge of a patch repair in the MSCP with material type A over a period of 215 days following installation.

The typical polarisation effects afforded by the anodes at a distance away from the edge of the patch repair from the bridge structure with material type B, between 110 and 195 days following installation are shown in Figure 4.13. It can be observed that the anodes affected the potentials to a distance of at least 400 mm away from the edge of the repair at 30 days after installation.

These are typical and re-occurring findings on the polarisation effect afforded by the anodes to steel in parent concrete at a distance from the edge of a patch repair with material type B, in the case of the bridge structure. The typical polarisation distance afforded by the anodes was 400 mm. Readings longer than 45 days after installation were not possible due to access restrictions on the bridge.

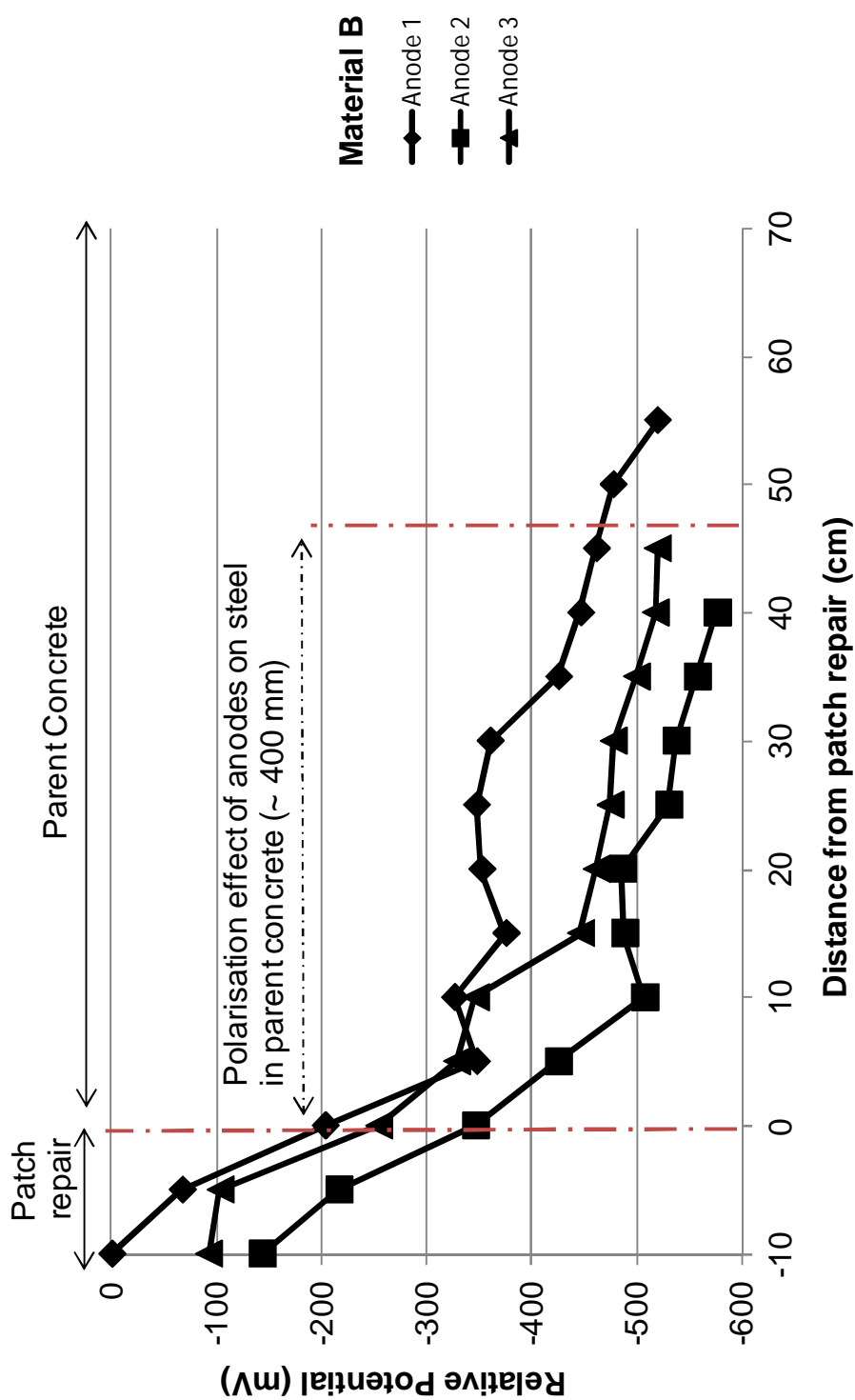

Figure 4.13 Polarisation effect of anodes at a distance from the edge of a patch repair from the bridge structure, with material type B, 30 days following installation.

The performance of the anodes within the patch repairs themselves was also examined in several locations by undertaking potential mapping around the repair. The results of a typical potential mapping over a period of time of up to 195 days are demonstrated in Figures 4.14 and 4.15. It can be observed that the anodic points identified in the potential mapping, coincided at all times with the location of the galvanic anodes (the anodic points have been circled in red). Looking at the imaginary relative potentials connecting these anodic spots, it can be observed that the potentials never rose higher than these lines. All the above suggest that there are no other anodic spots within the patch repair other than the location of the galvanic anodes. As such, the galvanic anodes are polarising the steel potentials to at least half the distance between anodes.

Overall, the performance monitoring data indicate that galvanic anodes installed in pre-drilled holes within the parent concrete can be used successfully to protect the steel reinforcement in the parent concrete. The extent of protection afforded by the anodes to steel reinforcement in parent concrete varies depending on the steel density (quantity), the spacing of the anodes, and the prevailing environmental conditions. In all cases examined, the galvanic anodes had an effect on the potentials of the steel in the parent concrete.

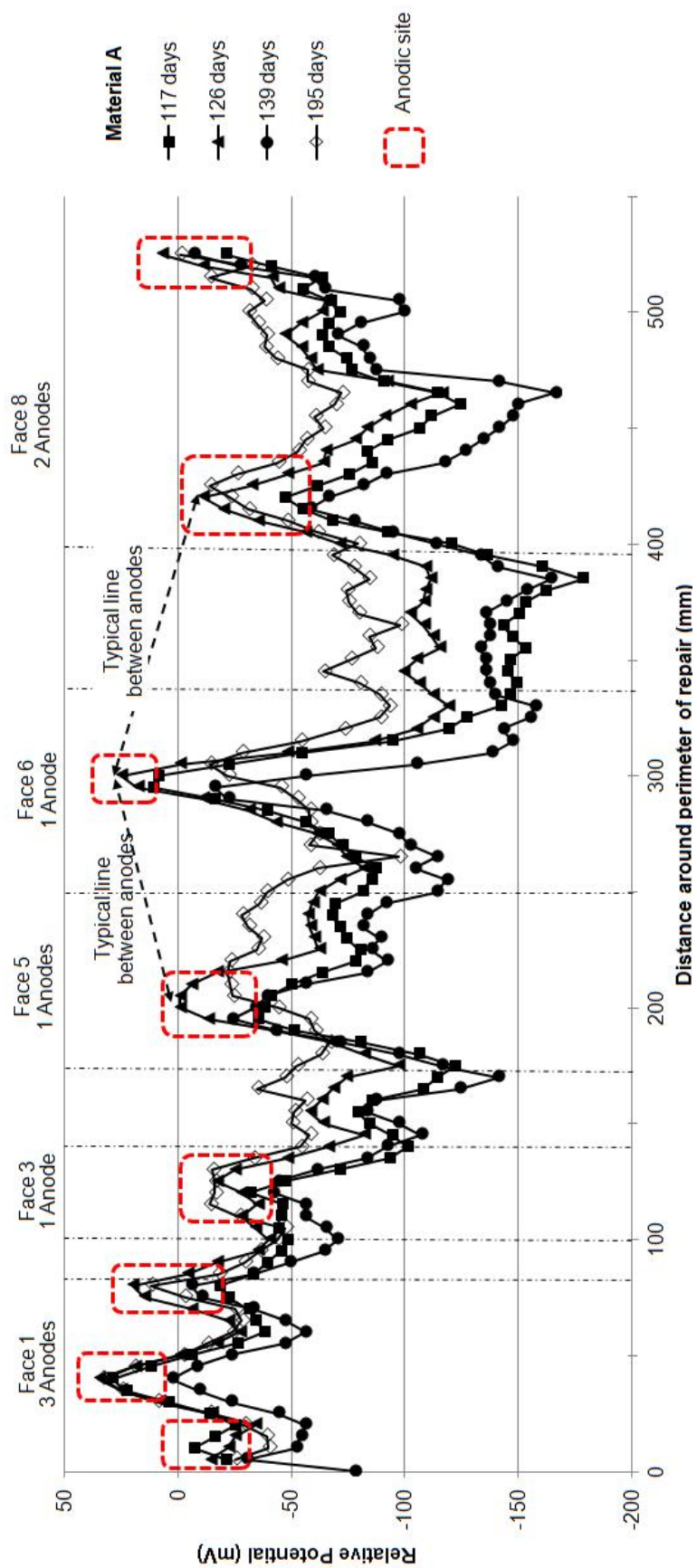

Figure 4.14 Potential mapping around a repair location with Material A up to 195 days following installation of the galvanic anodes.

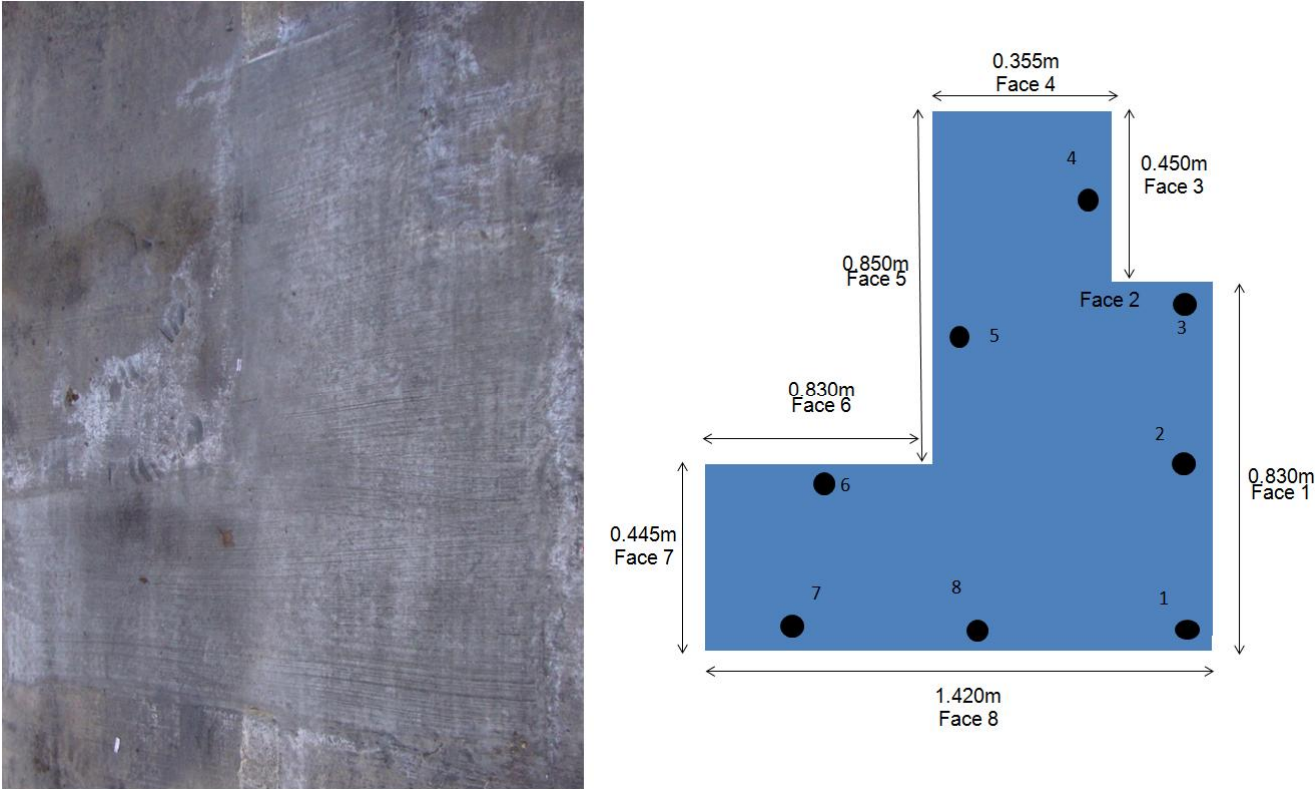

Figure 4.15 Diagrammatic outline of the patch repair and the location of anodes.

A repair material which conforms to standards for structural repairs will ensure that the likelihood of the repair being affected by shrinkage, settlement, segregation, bleeding, porous composition or inadequate bond will be significantly reduced. Such materials tend to have high resistivity, which will also promote current flow of galvanic anodes installed in parent concrete to steel also in parent concrete. All the above assist in extending the longevity of patch repairs.

Installation of galvanic anodes in pre-drilled holes requires additional work on site. However, this is offset by negating the requirement of encapsulating anodes installed in patch repairs within a proprietary low resistivity mortar to provide a conductive path to the substrate, as recommended by material manufacturers, prior to the application of the structural repair mortar.

Furthermore, the performance monitoring suggests that galvanic anodes exhibit variations in their performance over time. Although the exact environmental conditions were not recorded as part of this work, it was consistently observed that the anodes had a higher activity on wet and damp days. This suggests a responsive behaviour as also reported by Holmes et al. (2011) and Glass et al. (2012).

The findings of this work also suggest that potential mapping is an effective technique for measuring the performance of galvanic anodes. It can provide valuable information on whether the anodes are active or not and also identify the level of polarisation afforded to the adjacent reinforcement. This finding is in line with the work undertaken by Elsener (2001) who also used potential mapping to assess the effectiveness of concrete repairs in RC structures. Undertaking potential mapping at a small grid (50 mm), as in the case of this work, has the advantage that any potential localised corroding spots will be identified. In addition, the polarisation effect of the anodes can be also determined.

Based on the above, a new criterion may be adopted for assessing the performance of galvanic anodes. Potential mapping undertaken around the perimeter of a patch repair, with galvanic anodes installed in the parent concrete, should demonstrate that there are no corroding spots between locations of galvanic anodes. This is also in line with the work of Holmes et al. (2011).

Finally, it is possible to undertake potential mapping without a direct steel connection by measuring changes in the electrical field of the concrete induced by electrochemical activity of the steel against a fixed point. Such an approach may be particularly advantageous where connection to the reinforcement is not possible or not suitable (e.g. due to a fresh repair), or in cases of no electrical continuity. It is a non-destructive technique and it is best suited on

providing information on changes in the electrical field of the concrete over a period of time or between adjacent regions.

The limitation of this work may be associated with the time limitations on the data set collected. Further monitoring of the repairs was not possible as access was removed in the case of the bridge structure and the repairs were covered with a proprietary waterproofing in the case of the MSCP.

4.4 Hydrophobic Treatments – Research Package 4 (Appendix F)

As discussed in Chapter 2, the dominant mechanism for the transport of water in atmospherically-exposed elements is capillary suction (Kropp and Hilsdorf 1995, Ungricht 2004). Silanes are one form of hydrophobic treatments, which line the pores of the concrete (refer to Figure 4.16).

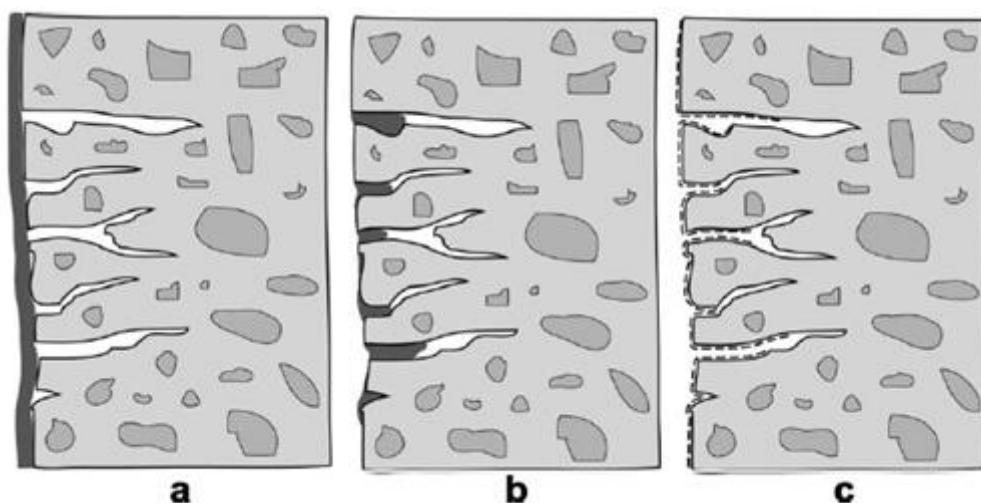

Figure 4.16 Categories of surface treatments a) coatings, b) pore blockers and c) pore liners (Medeiros and Helene 2009)

This work investigated the long-term performance of silanes following at least 12 years of service life, based on specimens extracted from full-scale RC structures.

Figure 4.17 illustrates the typical sub-structure arrangement of the motorway bridge supporting cross-beams that were examined during this study. Silanes have been applied to a total of 135 similar cross-beams across the UK's MLMV. Of these, 93 cross-beams were located in the viaduct (5600m) that was chosen for these investigations, whereas the remaining were distributed amongst four other viaducts.

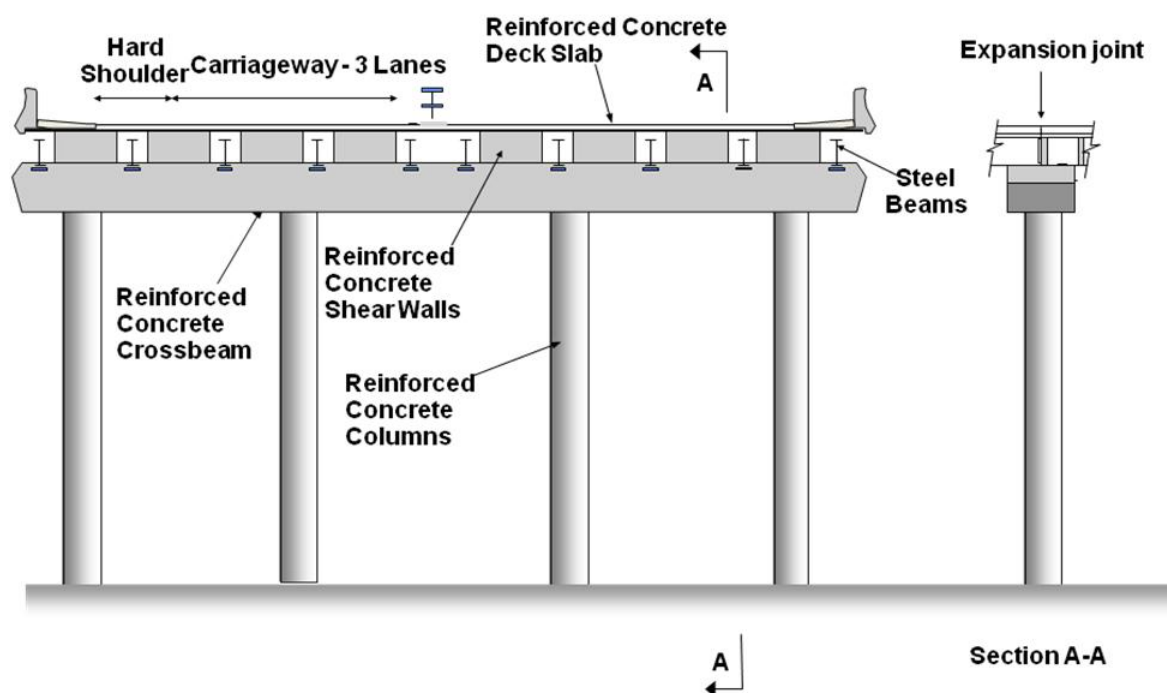

Figure 4.17 Typical sub-structure arrangement of the MLMV

Table 4.5 provides an outline summary of the structures investigated, their age and the service life of the silane treatment at the time of testing. For this research package control samples were also used. This was required in order to provide a reference for the residual hydrophobic effect afforded by the silane treatment.

Table 4.5 Structures details based on an average construction date of 1969.

Structure Reference	Year of silane application	Age of structure at silane application (years)	Age of silane at testing (years)	Age of structure at testing (years)
A1	1991	22	20	42
B1	1993	24	18	
B2	1993			
B3	1993			
B4	1993			
B5	1993			
B6	1993			
C1	1999	30	12	
D1	Control structures (No silane)	-	-	
D2				
D3				
D4				

A common testing regime to evaluate the performance of silanes is to measure chloride penetration profiles between silane treated and control specimens (Polder and de Vries 2001, Schueremans et al. 2007, Calder and McKenzie 2008). This is generally considered an indirect method. In this particular work, the performance of silanes was assessed by means of capillary absorption using the procedure described in BS EN 13057 (British Standards Institution 2002). Measuring capillary absorption provides direct information about the residual hydrophobic effect of the treatment and it allows for time-dependent performance analysis. Full details of the structures, specimens, testing methodology and material information are provided in Appendix F.

Figure 4.18 illustrates the average cumulative absorption for each structure's group of specimens over 4 hours of capillary absorption testing. It can be observed that specimens from all structures initially had a high rate of water absorption over the first 15 minutes of testing (0.08 hours or 0.29 hours^{0.5}). After this time, for the silane treated structures, in most cases the rate of water absorption reduced significantly or was almost negligible, indicating steady state conditions. For the control structures, in most cases, the rate of water absorption was reduced, but never eliminated.

This suggests that three distinct rates of water absorption may be derived (Table 4.6), i.e. initial between zero and 15 mins (0 to 0.29 hours^{0.5}), intermediate between 15 mins and 4 h (0.29 to 4.00 hours^{0.5}) and overall average (0 to 4.00 hours^{0.5}). Each structure also received a rank depending on the rate of water absorption it displayed; i.e a structure ranked first had the highest rate of water absorption for this particular time frame. This helps to provide a more informed assessment on the relative performance of structures such as B5 and C1 which had a high rate of water absorption over the first 15 minutes of testing, but thereafter reached steady state conditions.

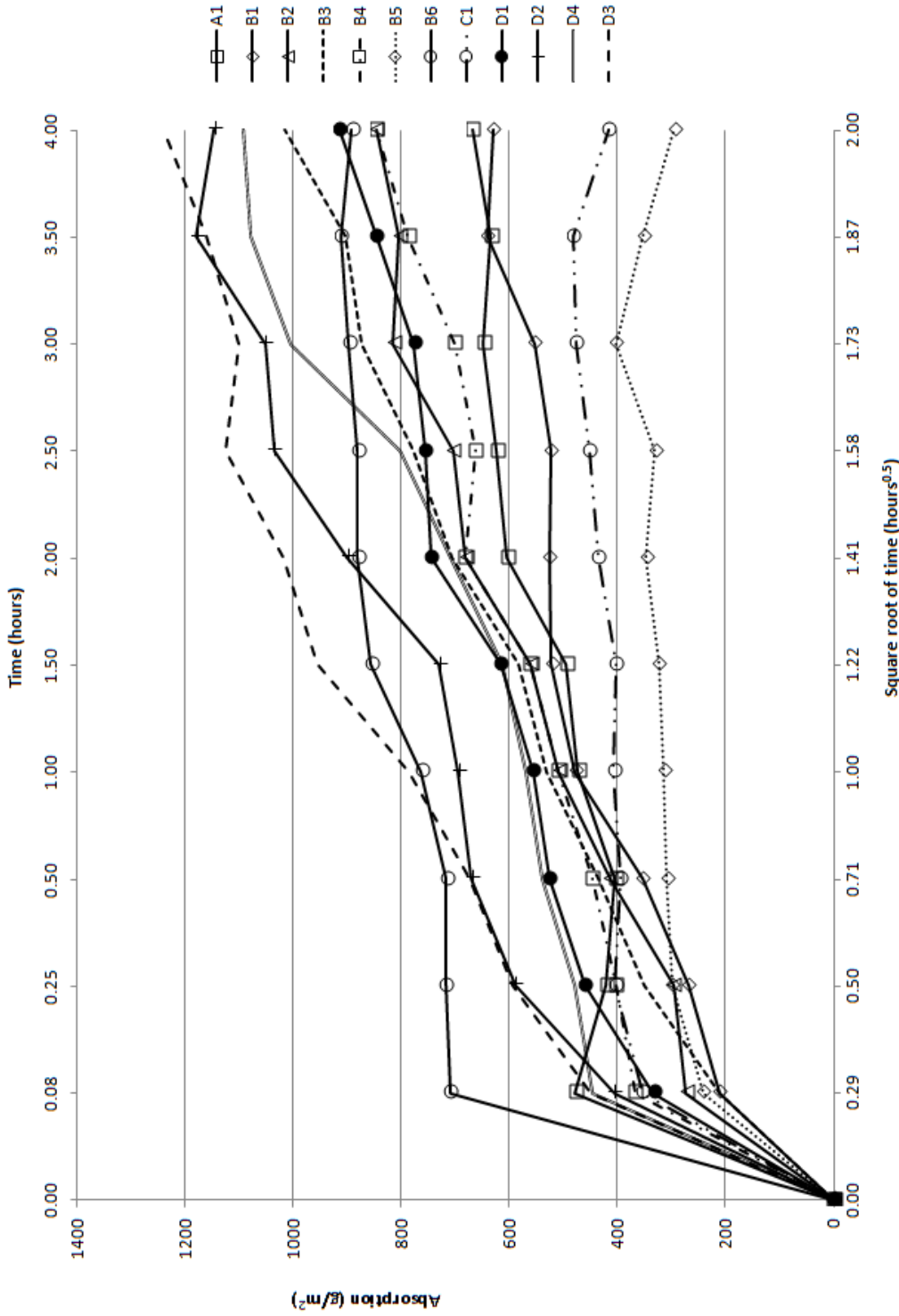

Figure 4.18 Average cumulative absorption for each structure’s group of specimens over 4 hours of capillary absorption testing.

It can be observed that control structures D2, D3 and D4 exhibited high rates of water absorption and they were ranked as three of the top four worst performing structures for the initial, intermediate and average rates of water absorption. Although all control structures (D1, D2, D3 and D4) initially performed better than silane treated structure B6, the latter quickly reached near steady state conditions (refer to its intermediate rate, Table 4.6) whereas control structures continued their water absorption.

Table 4.6 Initial, intermediate and average rate of water absorption in $\text{g/m}^2/\text{h}^{0.5}$ for each structure's group of specimens based on 4 hours of capillary absorption testing.

Structure ID	Initial rate ($\text{g/m}^2/\text{h}^{0.5}$) 0 - 15 min	Ranking (High to low rate)	Intermediate rate ($\text{g/m}^2/\text{h}^{0.5}$) 15 min – 4 h	Ranking (High to low rate)	Average rate ($\text{g/m}^2/\text{h}^{0.5}$) 0 min – 4 h	Ranking (High to low rate)	Age of silane at testing (years)
A1	841	6	124	9	335	9	20
B1	538	12	181	8	315	10	18
B2	593	11	275	5	423	7	
B3	703	9	332	1	507	4	
B4	805	8	221	7	422	8	
B5	599	10	26	11	148	12	
B6	1436	1	87	10	446	6	
C1	808	7	6	12	208	11	12
D1	920	5	227	6	456	5	-
D2	1178	3	278	4	573	2	-
D3	1188	2	323	2	620	1	-
D4	956	4	307	3	546	3	-

Silane treated structure B3 had a very low initial rate of water absorption when compared to all other structures. However, its intermediate rate of water absorption was the highest and it did not approach near steady state conditions within the 4 hours of the test. Its average rate of water absorption is comparable to that of specimens from control structures and may be associated with a diminished residual hydrophobic effect.

Structure C1, with the youngest silane treatment at 12 years at time of testing, was ranked average for its initial rate of water absorption, but thereafter reached steady state conditions and was the best performer based on the intermediate rate of water absorption. Structure B5, with the silane treatment at 18 years at time of testing, was one of the best performing based on initial, intermediate and average rates of water absorption and reached near steady state conditions after 15 minutes of testing.

The variance in the rate of water absorption observed may be partly explained by changes in the micro-structure of the specimens as water progresses from the cover zone (where concrete may be more porous and exhibit surface cracking) towards the core of the specimens. The thickness of this cover zone is affected by the quality control on-site and curing conditions during construction. In addition, as all the specimens were extracted from the top of the crossbeams, this effect may be exaggerated as concrete in this area will be more prone to bleeding.

The results suggest that the silane-treated specimens exhibited a residual protective effect even after 20 years of service life. Overall, the specimens from structure B6 (18 years old at time of testing) exhibited the lowest level of residual protection from the silane application when compared to the control specimens. Specimens from control structure D1 demonstrated the best performance. Indeed, they demonstrated similar performance to specimens from the poorest performing silane treated structures. This suggests that hydrophobic impregnations

such as silanes have a finite life and they will need to be re-applied during the service life of the structure to maintain their hydrophobic effects.

This is in line with the work by Polder and de Vries (2001), Schueremans et al. (2007) and Calder and McKenzie (2008) who also demonstrated long-term residual protective effects afforded by silanes. The findings suggest that hydrophobic treatments should be considered in the corrosion management strategy of RC structures.

As described earlier, a common approach for testing the performance of silane treatments is to obtain chloride concentrations over time. However, this was not possible for the current work as such historical information was not available, which poses a limitation. Thus, the performance of silanes was based solely on capillary absorption testing.

Another limitation of this work is that it investigated only a specific proprietary product which is no longer commercially available. As such, the results of this study should not be extrapolated to be directly applicable for assessing the performance of other proprietary products. However, the results provide the basis on how the performance of silanes can be assessed in service and provide an outline of how an effective hydrophobic treatment can reduce corrosion risk.

[This page is left intentionally blank]

5 FINDINGS AND IMPLICATIONS

This section provides a review of the main findings of the research, how these contribute to existing theory and practice, and the resulting benefits to the industrial sponsor.

5.1 SUMMARY OF KEY FINDINGS

As discussed in Chapter 2, this EngD programme comprised discrete research packages, each with its own objective. The key findings from each research package can be summarised as follows:

1. Macrocell activity appears to be a consequence rather than a cause of incipient anode formation in repaired concrete structures, as has previously been presented;
2. ICCP has persistent protective effects even after interruption of the protective current;
3. Discrete galvanic anodes installed in the parent concrete surrounding the patch repair are a feasible alternative to galvanic anodes embedded within the patch repairs of RC structures;
4. Silanes may have a residual hydrophobic effect even after 20 years of service.

Based on the nature of the findings, contributions to knowledge can also be presented against the following four strands:

- i. Performance of treatments and materials;
- ii. Methods of measurement;
- iii. Contributions to existing theory and practice;
- iv. Management framework changes.

These are presented in Table 5.1. Detailed discussion of the results and findings for each research work package are provided in the papers in Appendices B to F.

Table 5.1 Summary of contributions from each publication and objective against four main strands.

EngD Publication	Performance of treatments and materials (Section 5.1.1)	Methods of measurement (Section 5.1.2)	Contributions to existing theory and practice (Section 5.1.3)	Management of RC structures (Section 5.1.4)	Comments
Paper 1 (Appendix B)	X		X		Objective 1
Paper 2 (Appendix C)	X	X	X	X	Objective 2
Paper 3 (Appendix D)		X			
Paper 4 (Appendix E)	X	X	X		Objective 3
Paper 5 (Appendix F)	X			X	Objective 4

5.1.1 PERFORMANCE OF TREATMENTS AND MATERIALS

This section provides a summary of the findings from each contributing research package and how these contribute to the particular strand of performance of treatments and materials. This strand of work satisfied objectives 1, 2, 3 and 4.

Research Package 1 – Concrete Repair and Replacement (also refer to Appendix B)

Performance monitoring up to 250 days of patch repairs on full-scale RC structures yielded no evidence of incipient anode formation following repair.

The use of modern proprietary repair materials can permanently depress steel potentials within the repair area to more negative values than that of the steel in the older parent concrete. This may be associated with a higher pH of the fresh repair mortar due to the reaction between hydroxide and silica and a lower pH of the older parent concrete due to the reaction between hydroxide and carbon dioxide. In addition, modern proprietary repair

materials are specially formulated, usually with shrinkage compensating admixtures, which results in a reduction of permeability and oxygen availability following reinstatement of the repair.

It was also identified that cracks can occur at the interface between the parent concrete and the repair material following patch repair application as a result of drying, plastic shrinkage, thermal or stiffness incompatibility, poor curing, surface preparation, mechanical removal of defective concrete, or a combination of the above. All these increase the corrosion risk by lowering the resistance to chloride ingress. The extent of this effect is dependent on surface preparation, application techniques, curing, material properties and compatibility with the parent concrete. The presence of visible cracks may be obscured by trowel finishing the repair.

Research Package 2 – ICCP (also refer to Appendix C)

Performance monitoring of full-scale RC structures protected by conductive paint anode ICCP systems following a period of up to 33 months of no protective current has demonstrated that the reinforcement remained in a passive condition despite residual corrosion risk. In all cases examined, steel potentials shifted to more positive values and corrosion rates remained well below the 2 mA/m^2 corrosion threshold.

Older ICCP systems comprised a single zone for the whole of the structure whereas newer systems had multiple zones. However, this difference in the zone layout of the ICCP systems did not affect the results and the steel was rendered passive in all cases examined.

Research Package 3 – Galvanic Anodes (also refer to Appendix E)

Discrete galvanic anodes are traditionally embedded within the patch repairs of RC structures to offer corrosion prevention. This research investigated the performance of galvanic anodes

installed in the parent concrete surrounding the patch repair, in order to explore the performance of such a new arrangement and identify its potential for wide-scale application.

The results indicate that the anodes polarised the steel at a significant distance away from the patch repair interface and illustrates that such an arrangement may be advantageous when repairing RC structures as the corrosion prevention effect can be targeted at the steel in the surrounding parent concrete, which is considered to be at higher risk due to incipient anode development.

Research Package 4 – Hydrophobic Treatments (also refer to Appendix F)

From investigations of capillary water absorption on specimens extracted from eight silane treated and four untreated (control) RC structures, it was identified that silane treatments with a service life ranging between 12 and 20 years were still providing a residual hydrophobic effect.

Statistical analysis indicated a probability of less than 3% that the observed variance in the performance of control and silane impregnated structures occurs due to random effects, such as sampling choice. Thus, there is at least 97% confidence that the variance observed between the silane treated and control specimens was due to a residual hydrophobic effect.

In all but one structure, the most recent silane treated specimens outperformed the other older silane treated specimens, suggesting that there is a relationship between duration of environmental exposure and degradation of the silane treatment. The variation in performance of silanes from the same year of application in similar and neighbouring RC structures may be a result of differences in quality control, surface preparation, rate of silane application and/or daily local weather conditions and differences in the quality of the parent concrete.

5.1.2 METHODS OF MEASUREMENT

This section provides a summary of the findings from each contributing research package and how these contribute to the particular strand of methods of measurement. This strand of work satisfied objectives 2 and 3.

Research Package 2 – ICCP (also refer to Appendices C and D)

Corrosion rate measurement by means of polarisation resistance is an increasingly common technique for assessing the corrosion risk of RC structures. This work has demonstrated a testing arrangement for long-term monitoring and corrosion rate measurements on full-scale RC structures with a conductive anode ICCP system installed. Such an arrangement is readily reproducible in the field (Appendix C).

Transient analysis is an alternative technique to obtain information regarding the steel–concrete interface. For this, data is required at very low frequencies (mHz– μ Hz). This can be achieved by subjecting the specimen to a perturbation and analysing its resultant response. This research has successfully tested and evaluated the use of transient response analysis to full-scale structures for the first time. A testing arrangement readily reproducible in the field is proposed, together with the analytical corrosion rate calculation procedure (Appendix D).

Research Package 3 – Galvanic Anodes (also refer to Appendix E)

Measuring steel potentials against the potential of a standard reference electrode is a well-established non-destructive monitoring technique. Data is traditionally evaluated against published values of steel potentials in hardened concrete in order to assess corrosion risk. This research utilised relative potential measurements (i.e. without a direct connection to the reinforcement) to determine the change in the electrical field of the concrete induced by the electrochemical activity of the steel. This technique has been shown to be readily available for

use with full-scale RC structures. Such an approach may be particularly advantageous where connection to the reinforcement is not possible or not suitable (e.g. due to a fresh repair) or in cases of no electrical continuity. It is a non-destructive technique and it is best suited for providing information on changes in the electrical field of the concrete over a period of time or between adjacent regions.

5.1.3 CONTRIBUTION TO EXISTING THEORY AND PRACTICE

This section provides a summary of the findings from each contributing research package and how these contribute to the particular strand of contributions to existing theory and practice.

This strand of work satisfied objectives 1, 2 and 3.

Research Package 1 – Concrete Repair and Replacement (also refer to Appendix B)

Performance monitoring data obtained on real structures made with different concretes, repaired using different proprietary repair materials, exposed to a variety of environmental conditions, and subject to many other unknown variables associated with repair contracts, demonstrated that in all cases examined there was not a single instance where the potential within the repaired area rose to, or above, that in the parent concrete. This suggests that, on balance, macrocell activity is a consequence rather than a cause of incipient anode formation in repaired concrete structures as it has been presented generally in the literature (Page and Sergi 2000, Bertolini et al. 2004, Broomfield 2007, Concrete Society 2011, British Standards Institution 2012).

Based on the performance data discussed in section 4.1, the diagnosis of the cause of the incipient anode phenomenon adjacent to areas of concrete repair may reside in one or more of the following reasons:

- a) chlorides may enter the concrete through the interface between the parent and repair material
- b) the parent concrete adjacent to the repair area may have an above average level of residual chloride contamination that is sufficient on its own to cause corrosion
- c) preparation of a repair area may result in vibration damage at the steel interface with the adjacent parent concrete

The findings of the research also have an impact on the current industry practice for concrete repairs, as described by BS EN 1504-9 (British Standards Institution 2008). The presence of interfacial defects, substrate preparation, the age and composition of parent concrete and residual chloride content should be taken under consideration and assessed prior to any concrete repair scheme.

Research Package 2 – ICCP (also refer to Appendix C)

The performance of ICCP systems is traditionally associated with achieving a negative potential shift of 100mV (British Standards Institution 2012). Chloride extraction and re-alkalisation at the steel-concrete interface have generally been acknowledged as secondary effects only. This research has demonstrated that even after 33 months of no protective current being applied by the ICCP system, all the structures examined remained passive, despite a residual corrosion risk due to high levels of chlorides. The evidence suggests that ICCP has persistent protective effects in the absence of a negative potential shift, which may be more dominant than potential shift alone, which has an impact on the current design standards (British Standards Institution 2012). This should be taken under consideration and reflected in design standards through changes in the performance criteria of ICCP systems. Alternative criteria to a negative potential shift may include:

- a) depolarised steel potentials to be steady over time or moving towards more positive values;
- b) corrosion rates at selective critical locations less than 2 mA/m^2

Furthermore, the current suggestion for the protective design current ranges from 5 to 20 mA/m^2 of steel (British Standards Institution 2012). As discussed in Section 4.2, on several occasions the power supplies of the anode systems were voltage limited at current densities less than 20 mA/m^2 of concrete surface area. With the ratio of steel to concrete surface area ranging at 1.4:1 – 2:1, the actual protective current density delivered was significantly lower than the recommendations of the design standard. This suggests that lower design currents may be used and the absence of corrosion should be taken into consideration prior to the development of maintenance and replacement plans. This is supported by Polder et al. (2009) who also illustrated that a small current will be sufficient to induce and sustain passivity.

Research Package 3 – Galvanic Anodes (also refer to Appendix E)

Galvanic anodes have traditionally been placed within the concrete patch repair. Design standards suggest that the resistivity of repair mortars is limited to approximately half to twice that of the parent concrete (British Standards Institution 2012). This aims to eliminate any shielding effects from the repair material to the performance of galvanic anodes or other electrochemical systems. In practice, anode manufacturers have also stipulated limitations to the electrical resistivity of repair mortars. This results in limiting the choice of repair mortars and it may have a detrimental effect on the durability of the repairs.

The current work demonstrated that galvanic anodes installed in cavities within the parent concrete can successfully protect the steel reinforcement in the parent concrete. The use of BS EN 1504-3 (2004) compliant structural repair mortars did not have an effect on the

performance of the galvanic anodes, and polarisation of steel in parent concrete ranged at 400 – 600 mm for the two full-scale RC structures examined. The anodes deliver targeted protection to the steel in parent concrete around the patch, which is at greatest future corrosion risk, as opposed to cleaned steel within the patch repair. This is also in line with the work of Holmes et al. (2011).

5.1.4 IMPLICATIONS FOR THE MANAGEMENT OF RC STRUCTURES

This section provides a summary of the findings from each contributing research package and how these contribute to the particular strand of implications for the management of RC structures and identifies where changes can be implemented. This strand of work satisfied objectives 2 and 4.

Research Package 2 – ICCP (also refer to Appendix C)

This research examined the performance of conductive anode ICCP systems over a period of 33 months without protection. Such anodes were never capable of sustaining high levels of current densities. Based on the high density of reinforcement of the bridge structures considered, the actual protection delivered by these anode systems is considered low when compared to modern anode systems. However, the performance monitoring demonstrated that even a low cathodic protection current density was capable of inducing a substantial protective effect despite the residual corrosion risk of the structures examined.

The absence of corrosion should be taken into account when developing management strategies for the maintenance, repair and refurbishment of ICCP systems reaching the end of their service life. The replacement anode systems need only to deliver a low current density to

achieve polarisation and prevent corrosion initiation. Monitoring of existing ICCP systems with at least 5 years application, may be reasonably extended to annual intervals.

Overall, the findings of these results should not be used as the basis for the switching off of ICCP systems in an effort to extend anode life. The time to corrosion initiation is highly variable and depending on a number of factors such as previous contamination, environmental conditions etc.

Objective 4 – Hydrophobic Treatments (also refer to Appendix F)

The long-term residual effect of a silane treatment should be considered when determining the corrosion management strategy of a RC structure. Treatments as old as 20 years can still be present and offer a residual protective effect. Their presence and effectiveness can be evaluated by extracting cores to measure capillary absorption in the laboratory.

On-going maintenance can be established by occasional re-application of silanes and assessment of their performance. Such an approach may yield significant long-term durability benefits for existing RC structures. The current research demonstrated that the application of a new silane coating - even on previously silane coated specimens - had a beneficial effect on reducing water absorption by capillarity.

5.2 IMPLICATIONS/IMPACT ON INDUSTRIAL SPONSOR AND WIDER INDUSTRY

This research was based on testing full-scale RC structures, or specimens extracted from them. The advantage of this approach is that the findings can be exploited readily and applied to the wider construction industry. All of the work undertaken involved major asset owners who provided financial support and access to the structures for each research package. The individual sponsors received an industrial report following completion of each research

package which enabled them to utilise the findings and implement changes to their asset and corrosion management plans.

The following serve as a non-exhaustive list of the potential impact of this research on the wider industry:

- The following may affect the long-term durability of patch repairs:
 - i. chlorides may enter the concrete through the interface between the parent and repair material
 - ii. the parent concrete adjacent to the repair area may have an above average level of residual chloride contamination that is sufficient on its own to cause corrosion
 - iii. preparation of a repair area may result in vibration damage at the steel interface with the adjacent parent concrete
- Design standards for ICCP of atmospherically exposed RC structures are similar worldwide. This is enhanced from the fact that the recent British Standard (British Standards Institution 2012) holds an ISO status too. The findings of this work were focused on the performance of conductive coating anode systems following at least five years of service life. The findings are readily applicable to RC structures utilising such systems, not just in the UK but globally. They can benefit asset owners who can develop improved asset management and maintenance plans; but also designers in order to provide more cost-effective design solutions. Currently, a major highways asset owner in the UK has applied the results of this research in order to extend the intervals of inspection required, and has modified its maintenance programme in accordance to the findings of this research. The following are of particular importance:

- monitoring can be extended to greater intervals
- the absence of corrosion should be taken into consideration when developing maintenance strategies
- design current densities may be reduced
- The testing methodology developed for monitoring corrosion risk may be modified and can also be applied to ICCP systems utilising different anode systems.
- The findings may be structure and anode specific, however they could be extended to other ICCP systems that utilise different anode systems, with the prerequisite that they ought to be reviewed against each particular design, operation and maintenance records.
- Notwithstanding all of the above, the research has also raised awareness overseas. In particular, the Royal Melbourne Institute of Technology (RMIT) and Port of Melbourne (PoM) have recently initiated a programme of complimentary research in order to evaluate how the findings on the effects of ICCP to atmospherically exposed RC structures can also be applied to water exposed structures. The author is collaborating with both RMIT and PoM through the Industrial Sponsor (AECOM) to provide technical support and guidance.
- Galvanic anodes installed in parent concrete can be used in a variety of RC structures. The performance monitoring results are structure specific but they provide the basis with regards to their principles of operation. The following are of particular importance:

- there is no requirement to impose limitations on the repair materials to accommodate the presence of galvanic anodes, which may otherwise have a detrimental effect on the long-term performance of the repair
 - a new criterion in the form of polarisation distance being at least half the distance between galvanic anodes may be used to assess their performance
- The research work on galvanic anodes installed in parent concrete has already been successfully applied to a MSCP and a bridge, both in the UK. The author had direct involvement with both of these projects. Furthermore, the findings are currently used by the industrial sponsor to export knowledge in their overseas business.
- Although the research on the long-term performance of silane treatments is product and structure specific, they provide a basis for improving current corrosion management strategies. The findings and recommendations are currently being used by a major highways asset owner in the UK to supplement previous research (Calder and McKenzie 2008) and develop a new specification on the use of hydrophobic treatments in the UK.
- The research findings have also attracted particular attention from researchers at TNO Delft, The Netherlands who have undertaken previous research in the same field. In addition, they have used the findings of the present research work in their recent publication (Bertollini et al. 2013) in order to reinforce their views on the long-term performance of hydrophobic treatments such as silanes.

5.3 RECOMMENDATIONS FOR INDUSTRY/FURTHER RESEARCH

Research work forms part of a continuous cycle of learning, testing and development. The following items, categorised by research package, provide a non-exhaustive description of recommendations for additional research.

Research Package 1 – Concrete Repairs

The current work was limited on investigating the performance of on-site concrete patch repairs to two full-scale RC structures and three proprietary repair materials. Further research could be undertaken by examining the performance of such repairs in more full-scale RC structures and also examine the performance of other proprietary repair materials conforming to BS EN 1504-3 (2005).

Furthermore, additional laboratory testing similar to that of Chadwick (1993) and Cleland et al. (1997) could be undertaken with the exception of employing modern repair mortars complying with BS EN 1504-3 (2005).

Research Package 2 – ICCP

The current work was limited to atmospherically-exposed RC structures. Further work could be undertaken to establish the long-term persistent effects of ICCP on other environments such as structures in the tidal zone. This has been realised by RMIT and PoM in association with AECOM Australia and a research programme is currently underway.

Research work can also be undertaken on developing a more robust understanding of the relationship between charge and corrosion arrest. It would be particularly useful to undertake trials on full-scale RC structures again to evaluate how it can be utilised for the design of future electrochemical systems. This could lead to the development of alternative criteria for assessing corrosion arrest and passivity of the reinforcement.

Currently, re-alkalisation is considered as more dominant secondary beneficial effect than chloride extraction. The current work did not investigate changes to the pH around the steel-reinforcement environment. This is an area where future research work could be focused to establish the range and speed of such changes.

Research Package 3 – Galvanic Anodes

This particular work looked at the performance of galvanic anodes installed in parent concrete, but was limited to atmospherically exposed structures. Further work could be undertaken to investigate the performance of similar installations, but on concrete structures within the tidal zone. The current density is expected to increase during periods of wetness. However, current codes currently offer only limited guidance on the design current density required for structures in the tidal zone.

Of particular interest would be to undertake an extended research programme to compare the performance of different proprietary anodes installed both in the traditional design (i.e. within the repair) and with the new design (i.e. in parent concrete). The research programme could investigate the comparative performance between different proprietary repair mortars too as it is highly likely they will have a significant impact on the performance of galvanic anodes installed with the traditional design. Following, the research could be completed by undertaking the same testing regime but on full-scale RC structures in order to establish any correlation between laboratory produced concrete samples and full-scale aged concrete.

Research Package 4 – Hydrophobic Treatments

The current research work examined only the performance of a particular proprietary product based on the currently available structures. Further research work could be undertaken by extending the investigations to further proprietary products.

A shortcoming of the currently available literature is associated with non-destructive testing methods for assessing the presence, correct application and performance of hydrophobic treatments such as silanes. Future research could be focused on developing a reliable technique for use on site without the requirement for extracting cores.

Currently, there is a temporary suspension on the use of hydrophobic treatments by the UK's Highways Agency. This is associated with the inadequate performance of certain proprietary products although they currently comply with the requirements of BS EN 1504-2 (2004). Additional research could be undertaken to identify the present issues and develop recommendations which can be used to implement changes to the current codes of practice.

5.4 CRITICAL EVALUATION OF THE RESEARCH

Overall, the research has provided valuable information on the performance of materials and treatments, developed testing and monitoring arrangements for direct use on full-scale RC structures, challenges existing theory and industry practice and provides the basis for changes to the management of RC structures.

However, it is equally important to identify its limitations. These can be summarised in the following non-exhaustive list:

- Data for Research Package 1 was limited to a period of up to 246 days. Further monitoring of the repairs was not possible as access to the repairs was no longer available. In addition, the work examined the performance of two distinct structures with different parent concretes, for which historical information was limited. Also, it was not possible nor practical to obtain chloride concentration information in all the locations of parent concrete adjacent to the patch repairs.
- For Research Package 2, the ICCP systems examined were installed on bridge sub-structures and as such were not necessarily exposed to water spray carrying chlorides

from vehicular traffic. In addition, there was no information available on whether the structures were exposed to further chloride contamination after the installation of the ICCP systems.

- For Research Package 3, there were also time limitations on the data set collected. Further monitoring of the repairs was not possible as access to the repairs was no longer available.
- For Research Package 4, the main limitation was that the proprietary hydrophobic treatment product investigated is no longer commercially available. As such, the performance of this proprietary product when it was originally applied can only be approximated but not verified through testing. Furthermore, the results cannot be directly applicable to the performance of other proprietary hydrophobic treatment products.

From all of the above it can be observed that the primary limitations have been time-frames and the accessibility of structures. This is not surprising when dealing with full-scale bridge motorway RC structures. As such it is critical to evaluate what would be the effect on the findings of the research if these limitations were not in place.

- Research Package 1 – The time limitation does not affect the significance of the results as the period of testing was sufficient on its own to demonstrate that macrocell activity is not a cause but rather a consequence of incipient anode formation. Knowledge of the parent concrete composition would have aided the evaluation of the differences in properties between the parent and repair concrete.
- Research Package 2 – The ICCP systems were switched off for over 3 years without any signs of corrosion activity. If all of the structures could be exposed to identical

environmental conditions and their parent concrete properties were known, it may have been possible to evaluate the time needed for corrosion to initiate again.

- Research Package 3 – No major changes are anticipated on the performance of galvanic anodes. Data available in the literature has demonstrated that they have a long-term performance and their electrochemical activity depends on environmental exposure. The critical aspect of this work was to evaluate whether galvanic anodes installed in parent concrete could provide protection and whether they would be affected by structural repair mortars.
- Research Package 4 – Knowledge of the chloride content prior to the application of the hydrophobic impregnation would have quantified the reduction in uptake of corrosion inducing species such as chlorides.

Overall, the above limitations in the data set are not detrimental to the significance of the findings and in all cases examined there were robust conclusions providing information on the performance of materials and treatments, methods of measurement, existing theory and practice and management of RC structures.

6 REFERENCES

- Abreu C.M., Cristobal M.J., Montemor M.F., Novoa X.R., Pena G. and Perez M.C. 2002, Galvanic coupling between carbon steel and austenitic stainless steel in alkaline media, *Electrochimica Acta*, 47, pp. 2271 – 2279.
- Almusallam AA, Khan FM, Dulajan SU and Al-Amoudi OSB 2003, Effectiveness of surface coatings in improving concrete durability, *Cement and Concrete Composites*, 25, pp. 381 – 473.
- Alvarez M. G. and Galvele J. R. 1984, The mechanism of pitting of high purity iron in NaCl solutions, *Corrosion Science* (24), pp. 27 – 48.
- American Concrete Institute, Evaluation and minimization of bruising (microcracking) in concrete repair, Report 364.7T-02(11), USA, 2002.
- Andrade C. and Alonso C. 1996, Corrosion rate monitoring in the laboratory and on-site, *Construction and Building Materials*, 10, pp. 315 – 328.
- Andrade C. and Alonso C. 2004, Test methods for on-site corrosion rate measurement of steel reinforcement in concrete by means of the polarisation resistance method, RILEM TC 154-EMC: Electrochemical techniques for measuring metallic corrosion, *Materials and Structures* 37, pp. 623 – 643.
- American Concrete Institute, Corrosion of metals in concrete, Report 222, Michigan, USA 1985.
- Angst U., Elsener B., Larsen C.K. and Vennesland O. 2009, Critical chloride content in reinforced concrete – A review, *Cement and Concrete Research* (39), pp. 1112 – 1138.
- ASTM 2009, Standard Test Method for Corrosion Potentials of Uncoated Reinforcing Steel in Concrete, American Society for Testing and Materials, West Conshohocken, Pennsylvania, USA.
- Bamforth P.B., Price W.F. and Emerson M., International review of chloride ingress into structural concrete, TRL Contractor Report 359, Transport Research Laboratory, Edinburgh, Scotland, 1997.
- Basheer P.A.M., Basheer L., Cleland D.J. and Long A.E. 1997, Surface treatments for concrete: assessment methods and reported performance, *Construction and Building Materials* (11), pp. 413 – 429.
- Basheer L, Cleland DJ, Long AE 1998, Protection provided by surface treatments against chloride induced corrosion, *Materials and Structures* (31), pp. 459 – 464.
- Bennett J. Schue T.J., Clear K.C., Lankard D., Hartt W.H. and Swiat W.J. 1993, Electrochemical Chloride Removal and Protection of Concrete Bridge Components: Laboratory Studies, Strategic Highway Research Program, SHRP-S-657, National Research Council, Washington DC.

Bertolini L., Gastaldi M., Pedferri M.P., Pedferri P. and Pastore T., in: Proceedings of the International Conference on Corrosion and Rehabilitation of Reinforced Concrete Structures, Orlando, USA, 1998.

Bertolini L., Elsener B., Pedferri P., and Polder R., Corrosion of steel in concrete, prevention, diagnosis, repair, Wiley-VCH, Germany, 2004.

Bertolini L., Elsener B., Pedferri P., Redaelli E. and Polder R., Corrosion of steel in concrete, prevention, diagnosis, repair, 2nd Edition, Wiley-VCH, Germany, 2013.

Brewer R. Your PhD Thesis, How to plan, draft, revise and edit your thesis, Studymates, Abergele, UK, 2007.

Broomfield J.P., Corrosion of steel in concrete: understanding, investigation and repair, 2nd ed., Taylor and Francis, UK, 2007.

Broomfield J.P. and Tinnea J.S., Cathodic Protection of Reinforced Concrete Bridge Components, Final Report. ID No: SHRPCUWP92618, 1992.

British Standards Institution, BS 1881-124:1988, Testing concrete. Methods for analysis of hardened concrete, BSI, London, 1988.

British Standards Institution, BS EN 1504-2:2004, Products and systems for the protection and repair of concrete structures – Definitions, requirements, quality control and evaluation of conformity: Part 2. Surface protection systems for concrete, BSI, London, 2004.

British Standards Institution, BS EN 1504-3:2004, Products and systems for the protection and repair of concrete structures – Definitions, requirements, quality control and evaluation of conformity: Part 3. Structural and non-structural repair, BSI, London, 2005.

British Standards Institution, BS EN 1504-9:2008, Products and systems for the protection and repair of concrete structures – Definitions, requirements, quality control and evaluation of conformity: Part 9. General principles for the use of products and systems, BSI, London, 1997.

British Standards Institution, BS EN ISO: 12696:2012, Cathodic protection of steel in concrete, BSI, London, 2012.

British Standards Institution, BS EN 13057:2002, Products and systems for the protection and repair of concrete structures – Test methods – Determination of resistance of capillary absorption, London, 2002.

Brown, M. C. & Sharp, S. R. 2008. "Survey of Cathodic Protection Systems on Virginia Bridges" Report VTRC 07-R35, Virginia Transportation Research Council (www.virginia.gov/vtrc/main/online_reports/pdf/07-r35.pdf).

Calder A. and McKenzie M. 2008, Transportation Research Laboratory, Published Project Report 362, Performance of impregnants.

-
- Chadwick R., Performance of concrete repair materials as corrosion protection for reinforcement, Ph.D. Thesis, University of Surrey, 1993.
- Christodoulou C., Glass G., Webb J., Ngala V., Beamish S. and Gilbert P., Evaluation of Galvanic Technologies available for Bridge Structures, Structural Faults and Repair Conference, Edinburgh, Scotland, 2008, ISBN 0-947644-62-7.
- Christodoulou C., Gareth G., Webb J. 2009, Corrosion management of concrete structures, *The Structural Engineer* (87), pp. 20 – 22.
- Christodoulou C., Glass G., Webb J., Austin S.A. and Goodier C.I., A new approach for the patch repair of car parks using galvanic anodes, Concrete Solutions 2011, : Grantham, M., Mechtcherine, V. and Schneck, U. (eds). Concrete Solutions 2011: Proceedings of the International Conference on Concrete Solutions 2011. London: CRC Press, ISBN 978-0-203-13468-9.
- Christodoulou C, Sharifi A, Das S, Goodier C 2013, Cathodic Protection on the UK's Midland Links motorway viaducts, *Proceedings of the Institution of Civil Engineers: Bridge Engineering*, DOI information: 10.1680/bren.12.00015
- Cleland D.J., Yeoh K.M., and Long A.E. 1997, Corrosion of reinforcement in concrete repair, *Construction and Building Materials* (11), pp. 233 – 238.
- Concrete Society, Technical Report 50, Guide to surface treatments for protection and enhancement of concrete, Surrey, UK, 1997.
- Concrete Society, Technical Report 54, Diagnosis of deterioration in concrete structures, Surrey, UK, 2000.
- Concrete Society, Technical Report 61, Enhancing reinforced concrete durability, Surrey, UK, 2004a
- Concrete Society, Technical Report 60, Electrochemical tests for reinforcement corrosion, Surrey, UK, 2004b.
- Concrete Society, Technical Report 31, Permeability testing of site concrete, Surrey, UK, 2008.
- Concrete Society, Technical Report 69, Repair of concrete structures with reference to BS EN 1504, Surrey, UK, 2009.
- Concrete Society, Technical Report 22, Non-structural cracks in concrete, Surrey, UK, 2010.
- Concrete Society, Technical Report 73, Cathodic Protection of Steel in Concrete, Surrey, UK, 2011.
- Corrosion Prevention Association, Technical Note 3, Cathodic Protection of Steel in Concrete, The International Perspective, Bordon, UK, 2011.

Design Manual for Road and Bridges, Volume 3, Section 3, Part BA 35/1990 Inspection and Repair of Concrete Highway Structures, Departmental Standard, UK, 1990.

Dugarte M. And Sagiúes A.A., Galvanic point anodes for extending the service life of patched areas upon reinforced concrete bridge members, Contract No. BD544-09, Final Report to Florida Department of Transportation, Tampa, Florida, USA, 2009.

Dugarte M., Sagiúes A.A., Powers R.G. and Lasa I.R. 2007, Evaluation of point anodes for corrosion prevention in reinforced concrete, Corrosion 2007, Paper No.07304.

Dunleavy P., Authoring a PhD, How to plan, draft, write and finish a doctoral thesis or dissertation, Palgrave, London, 2003.

Elsener B. 2001, Half-cell potential mapping to assess repair work on RC structures, *Construction and Building Materials*, 15, pp. 133 – 139.

Elsener B. 2003, Half cell potential measurements – Potential mapping on reinforced concrete structures, RILEM TC 154-EMC: Electrochemical techniques for measuring metallic corrosion, *Materials and Structures* 36, pp. 461 –471.

Everett, L.H. and Treadaway, K.W.J. 1980, Deterioration due to corrosion in reinforced concrete, Corrosion Prevention Control, Garston, Building Research Establishment, Information Paper 12.

Fellows R. and Liu A., Research methods for construction, Wiley-Blackwell, Chichester, UK, 2008.

Glass G.K. 1995, An assessment of the coulometric method applied to the corrosion of steel in concrete, *Corrosion Science*, 37, pp. 597 – 605.

Glass G.K. 2007, Deterioration of Steel Reinforced Concrete, *Comprehensive Structural Integrity*, Chapter 6.07, pp. 321 – 350.

Glass G. K. and Buenfeld N. R. 1996, Reinforced concrete – its principles of deterioration and repair. In: Macdonald S (ed) *Modern Matters – Principles and Practice in Conserving Recent Architecture*. Shaftesbury, UK: Donhead Publishing. 101-112

Glass G. K. and Buenfeld N. R. 1997, The presentation of the chloride threshold level for corrosion of steel in concrete, *Corrosion Science* (39), pp 1001-1013.

Glass G. K., Ready B. and Buenfeld N. R. 2000, The participation of bound chloride in passive film breakdown on steel in concrete, *Corrosion Science* (42), pp. 2013 – 2021.

Glass G.K. and Buenfeld N.R. 2000, Chloride-induced corrosion of steel in concrete, *Progress in Structural Engineering and Materials*, 2, pp. 448 – 458.

Glass G. K. and Chadwick J. R. 1994, An investigation into the mechanisms of protection afforded by a cathodic current and the implications for advances in the field of cathodic protection, *Corrosion Science* (36), pp. 2193 – 2209.

Glass G. K., Christodoulou C. and Holmes S.P. 2012, Protection of steel in concrete using galvanic and hybrid electrochemical treatments, IN: Alexander, M.G. et al. (eds.), *Concrete Repair, Rehabilitation and Retrofitting III - Proceedings of the 3rd International Conference on Concrete Repair, Rehabilitation and Retrofitting, ICCRRR 2012*, pp. 523 – 526, ISBN 978-0-415-89952-9.

Glass, G.K., Davison, N. and Roberts, A. 2006, Pit realkalisation and its role in the electrochemical repair of reinforced concrete. *Journal of Corrosion Science and Engineering* (9).

Glass G.K., Davison N. and Roberts A.C. 2008, Hybrid corrosion protection of chloride contaminated concrete, *Proceedings of the Institution of Civil Engineers, Construction Materials*, 161, pp. 163 – 172.

Glass, G.K., Davison, N. and Roberts, A., *Monitoring Method*, UK Patent GB 2449039 B, 2010.

Glass G.K., Hassaein A.M. and Buenfeld N.R. 1997, Obtaining Impedance Information on the Steel – Concrete Interface, *Corrosion*, 54, pp. 887 – 897.

Glass G.K., Hassanein A.M. and Buenfeld N.R. 1998, Low frequency impedance data by Laplace transformation of coulometrically induced transients, *Electrochimica Acta*, 43, pp. 1863 – 1871.

Glass G. K., Ready B. and Clark L. 2007, Making concrete immune to chloride induced corrosion, *Proceedings of the Institution of Civil Engineers, Construction Materials*, 160 (4), pp. 155 – 164.

Holmes S.P., Wilcox G.D., Robins P.J., Glass G.K. and Roberts A.C. 2011, Responsive behaviour of galvanic anodes in concrete and the basis for its utilisation, *Corrosion Science* (53), pp. 3450 – 3454.

Hussey J. And Hussey R., *Business Research: A Practical Guide for Undergraduate and Postgraduate Students*, Macmillan, London, 1997.

Ibrahim M., Al-Gahtani S., Maslehuddin M. and Almusallam A.A. 1997, Effectiveness of concrete surface treatment materials in reducing chloride-induced reinforcement corrosion, *Construction and Building Materials* (11), pp. 443 – 451.

Ihekwa N.M., Hope B.B. and Hansson C.M. 1995, Pull-out and bond degradation of steel rebars in ECE concrete, *Cement and Concrete Research*, 26, 2, pp. 267 – 282.

Kropp J. and Hilsdorf H.K., RILEM Report 12, *Performance criteria for concrete durability*, Taylor and Francis, Oxford, UK, 1995.

Lau K. and Sagüés A.A., Corrosion of steel in locally deficient concrete, Contract No. BD544-31, Final Report to Florida Department of Transportation, Tampa, Florida, USA, 2009.

Marcotte T.D., Hansson C.M. and Hope B.B. 1999, The effect of the electrochemical chloride extraction treatment on steel-reinforced mortar Part I: Electrochemical measurements, *Cement and Concrete Research* (29), pp. 1555 – 1560.

Morgan D.R. 1996, Compatibility of concrete repair materials and systems, *Construction and Building Materials* (10), pp. 57 – 67.

Medeiros M.H.F. and Helene P. 2008, Efficacy of surface hydrophobic agents in reducing water and chloride ion penetration in concrete, *Materials and Structures* (41), pp. 59 – 71.

NACE International Publication 01105, Item No. 24224, *Sacrificial Cathodic protection of Reinforced Concrete Elements — A State-of-the-Art Report*, Houston, USA, 2005.

Orazem M.E. and Tribollet B., *Electrochemical Impedance Spectroscopy*, The Electrochemical Society Series, John Wiley & Sons, New Jersey, USA, 2008.

Page C.L. and Sergi G. 2000, Developments in cathodic protection applied to reinforced concrete, *Journal of Materials in Civil Engineering* (1), pp. 8 – 15.

Page C. L. and Treadaway K. W. J. 1982, Aspects of the electrochemistry of steel in concrete. *Nature*, 297, No 5862, pp. 109 – 115.

Pianca, F. and Schell, H.C. 2004, Evaluation of new sacrificial anode cathodic protection systems for highway bridge decks, *Corrosion 2004*, Paper No. 04340.

Polder R., Peelen W.H.A., Stoop B.T.J. and Neeft E.A.C., Early Stage Beneficial Effects of Cathodic Protection in Concrete Structures, Nice, France, Eurocorr 2009.

Polder R.B. and de Vries H. 2001, Prevention of reinforcement corrosion by hydrophobic treatment of concrete, *Heron* (46), pp. 227 – 238.

Polder R., Tondi A. and Cigna, Concrete resistivity and corrosion rate of reinforcement, TNO report 93-BT-r0170, TNO Delft, 1993.

Presuel-Moreno F.J., Sagüés A.A. and Kranc S.C. 2002, Steel activation in concrete following interruption of long-term cathodic polarisation, *Corrosion 2002*, Paper no. 02259.

Qian S, Zhang J and Qu D 2006, Theoretical and experimental study of microcell and macrocell corrosion in patch repairs of concrete structures, *Cement and Concrete Composites*, 28, pp. 685 – 695.

Qian S., Qu D. and Coates G. 2006, Galvanic coupling between carbon steel and stainless steel reinforcements, *Canadian Metallurgical Quarterly*, 45, pp. 475–484.

Raupach M. 1996, Chloride-induced macrocell corrosion of steel in concrete – theoretical, background and practical consequences, *Construction Building Materials*, 10, pp. 329 – 338.

-
- Sagues A. A. and Powers R. G., Sprayed galvanic anodes for concrete marine bridge substructures, Strategic Highway Research Program, Report No. SHRP-S-405, USA 1994.
- Schiessl P. and Raupach M. 1997, Laboratory studies and calculations on the influence of crack width on chloride-induced corrosion of steel in concrete, *ACI Materials Journal* (94), pp. 56 – 62.
- Schueremans L, Gemert DV and Giessler S 2007, Chloride penetration in RC-structures in marine environment-Long term assessment of a preventative hydrophobic treatment, *Construction and Building Materials* (21), pp. 1238 – 1249.
- Sergi G. and Glass G.K. 2000, A method of ranking the aggressive nature of chloride contaminated concrete, *Corrosion Science* (42), pp. 2043 – 2049.
- Sharpe S.R. and Brown M.C., Survey of Cathodic Protection Systems on Virginia Bridges, VTRC 07-R35, Virginia Transportation Research Council, USA, 2007.
- Siegwart M., Lyness J.F., McFarland B.J. and Doyle G. 2005, The effect of electrochemical chloride extraction on pre-stressed concrete, *Construction and Building Materials*, 19, pp. 585 – 594.
- Smith J.L. and Virmani Y.P., Materials and methods for corrosion control of reinforced and prestressed concrete structures in new construction, Federal Highway Administration Report, FHWA-RD-00-081, Washington DC, 2000.
- Stratful R.E. 1957, The corrosion of steel in a reinforced concrete bridge, *Corrosion* 13, pp. 43 – 48.
- Stratful R.F. 1973, Preliminary Investigations of Cathodic Protection of a Bridge Deck, Caltrans, http://www.dot.ca.gov/hq/research/researchreports/1973/bridge_deck.pdf (accessed 28th January 2013).
- Tilly G.P. and Jacobs J., Concrete repairs, Performance in service and current practice, BRE Press, Bracknell, UK, 2007.
- Transportation Research Board, NCHRP Synthesis 398, Cathodic protection for life extension of existing reinforced concrete bridge elements, Washington D.C., USA 2009.
- Ungricht H., Wasserhaushalt und Chlorideintrag in Beton – Einfulls der Exposition und der Betonzusammensetzung, Ph. D. Thesis (In German), Universities of Zurich and Basel, 2004.
- Vries J. and Polder R.B. 1997, Hydrophobic treatment of concrete, *Construction and Building Materials* (11), pp. 259 – 265.
- Wallbank E.J., The performance of concrete in bridges, A survey of 200 Highway Bridges, HER Majesty's STATIONERY Office, London, UK, 1989.

Yang CC, Wang LC and Weng TL 2004, Using charge passed and total chloride content to assess the effect of penetrating silane sealer on the transport properties of concrete, *Materials Chemistry and Physics*, 85, pp. 238 – 244.

Zhao Y., Yu J., Wu Y. and Jin W. 2012, Critical thickness of rust layer at inner and out surface cracking of concrete cover in reinforced concrete structures, *Corrosion Science*, 59, pp. 316 – 323.

APPENDIX A LIST OF ADDITIONAL PUBLICATIONS

- Christodoulou C, Goodier C, Austin S, Webb J, Glass G, A new arrangement of galvanic anodes for the repair of reinforced concrete structures, *Construction and Building Materials*, 48 (2013), pp. 708 – 716 DOI information: 10.1016/j.conbuildmat.2013.09.062
- Christodoulou C, Goodier C, Austin S, Webb J, Glass G, Hybrid corrosion protection of a prestressed concrete bridge, Presented at EUROCORR 2013, 01 - 05 September 2013, Estoril, Portugal.
- Christodoulou C, Goodier C, Austin S, Webb J, Glass G, Long-term performance of surface impregnation of reinforced concrete structures with silane, *Construction and Building Materials*, 48 (2013), pp. 708 – 716 DOI information: 10.1016/j.conbuildmat.2013.07.038
- Christodoulou C, Sharifi A, Das S, Goodier C, Cathodic Protection on the UK's Midland Links motorway viaducts, *Proceedings of the Institution of Civil Engineers: Bridge Engineering*, (2013), DOI information: 10.1680/bren.12.00015
- Christodoulou C, Goodier C, Austin S, Webb J, Glass G, Diagnosing the cause of incipient anodes in repaired reinforced concrete structures, *Corrosion Science*, 69 (2013), pp. 123 – 129 DOI information: 10.1016/j.corsci.2012.11.032
- Glass G, Christodoulou C, Towards rendering steel reinforced concrete immune to corrosion, Australasian Corrosion Association 2012 Annual Meeting, 11-14 November 2012, Melbourne, Australia, 2012, paper 159, 11p.
- Christodoulou C, Goodier C, Austin S, Glass G and Webb J, On-site transient analysis for the corrosion assessment of reinforced concrete, *Corrosion Science*, 62 (2012), pp. 176 – 183 DOI information: 10.1016/j.corsci.2012.05.014
- Glass G, Christodoulou C and Holmes SP, 2012, Protection of steel in concrete using galvanic and hybrid electrochemical treatments, IN: Alexander, M.G. et al. (eds.), *Concrete Repair, Rehabilitation and Retrofitting III - Proceedings of the 3rd International Conference on Concrete Repair, Rehabilitation and Retrofitting, ICCRRR 2012*, pp. 523 – 526, ISBN 978-0-415-89952-9.
- Christodoulou C, Goodier C, Austin S, Glass G and Webb J, Assessing the long-term durability of silanes on reinforced concrete structures, IN: *Proceedings of the 1st International Congress on Durability of Concrete*, Trondheim, Norway, 17 - 21 June 2012, 14pp, ISBN 978-82-8208-031-6
- Christodoulou C, Goodier C, Austin S, Glass G and Webb J, Protecting the UK's critical infrastructure – Impressed Current Cathodic Protection on the Midland Links Motorways Network, IN: Tyrer, M. (ed). *Young Researchers' Forum in Construction Materials Proceedings*, 17 May 2012, London, UK, 4pp, ISBN: 978-0-901001-36-8.

- Christodoulou C, Goodier C, Austin S, Glass G and Webb J, Investigations on the incipient anode phenomenon following patch repairs for reinforced concrete structures. IN: Ferreira, R.M., Gulikers, J. and Andrade, C. (eds.) Proceedings of VTT TECHNOLOGY 65: V International PhD Student Workshop on Durability of Reinforced Concrete From Composition to Service Life Design, Helsinki, Finland, 2012, pp. 24-31, ISBN 978-951-38-7899-3.
- Christodoulou C, Bulmer M, Cocksedge C, Wilkinson D, Cooper J, Hill P, Austin S and Goodier C, Humber Bridge – Suppressing Main Cable Corrosion by Means of Dehumidification, IN: Proceedings of the 18th International Corrosion Congress, 20-24 November 2011 – Perth, Australia, ISBN 9781618393630.
- Christodoulou C, Glass G, Webb J, Austin S and Goodier C, Corrosion risk of reinforced concrete structures following 3 years of interrupted cathodic protection, IN: Proceedings of the 18th International Corrosion Congress 2011, 20-24 November– Perth, Australia, ISBN 9781618393630
- Christodoulou C, Glass G, Webb J, Austin S and Goodier C, A new approach for the patch repair of car parks using galvanic anodes, Concrete Solutions 2011, : Grantham, M., Mechtcherine, V. and Schneck, U. (eds). Concrete Solutions 2011: Proceedings of the International Conference on Concrete Solutions 2011. London: CRC Press, ISBN 978-0-203-13468-9.
- Christodoulou C, Glass G, Webb J, Austin S and Goodier C, Investigating the effect of Interrupted Cathodic Protection on reinforced concrete structures. Presented at EUROCORR 2010, 13 - 17 September 2010, Moscow, Russia, ISBN 978-1-61782-402-9.
- Christodoulou C, Glass G, Webb J, Austin S and Goodier C, Assessing the long term benefits of Impressed Current Cathodic Protection, *Corrosion Science*, 52 (2010), pp. 2671 – 2679 DOI information: 10.1016/j.corsci.2010.04.018

APPENDIX B PAPER 1

Full Reference

Christodoulou C, Goodier C, Austin S, Webb J, Glass G, Diagnosing the cause of incipient anodes in repaired reinforced concrete structures, *Corrosion Science*, 69 (2013), pp. 123 – 129
DOI information: 10.1016/j.corsci.2012.11.032

Abstract

The incipient anode (or halo) effect often occurs on repaired reinforced concrete structures. The diagnosis of this problem is widely reported to be macrocell activity. This diagnosis is based on very limited data. Indeed potential measurements on field structures repaired with proprietary materials have provided data that suggest that macrocell activity is not a cause of incipient anode formation. Alternative mechanisms that may cause incipient anode activity include repair/parent material interface effects, residual chloride contamination within the parent concrete, and/or vibration damage to the steel/parent concrete interface during repair area preparation.

Keywords – Concrete, steel reinforced concrete, corrosion.

Paper type – Journal

1 INTRODUCTION

Corrosion of steel reinforcement affects many concrete structures. Patching is a common repair technique that involves the removal of physically deteriorated concrete (by hydro-demolition or jack hammer), cleaning the steel reinforcement within the patch and finally restoring the concrete profile with a proprietary repair mortar [1 – 2]. This process renders the steel within the repair area passive [3]. In many cases corrosion-induced deterioration has subsequently been observed in the parent concrete in the immediate area around the patch repairs, sometimes within a few months following completion of the repair process [4]. This phenomenon is known as incipient or ring anode formation or the halo effect [3, 5].

The concept that macrocell activity (the formation of spatially separated anodes and cathodes) causes the incipient anode effect was first introduced by Page and Treadaway [6] in 1982. They suggested that the redistribution of anodic and cathodic sites following concrete repair affects future corrosion risk. Since that time the macrocell diagnosis developed to the extent that it is almost exclusively considered as the cause of incipient anode formation in the corrosion literature. Some quotes taken from prominent literature in this field include:

- i. Unless “*stringent measures are taken to remove all significantly chloride-contaminated material from around the corroding areas, the likelihood of corrosion reappearing and cracking the concrete adjacent to the repairs is high. This is because replacement of the most intensely anodic regions of the reinforcement with passive steel in the repaired zones effectively removes the adventitious form of sacrificial anode CP*” (cathodic protection) “*that was formerly being applied to the steel in the neighbouring regions. Hence, the potential of the metal in these less severely contaminated areas can rise to a value at which pitting is liable to be initiated*” [3].
- ii. “*If only concrete near the corroded reinforcement is replaced, the attack may start in the areas near to those repaired because they no longer benefit from the cathodic polarisation and, moreover, pitting corrosion may even be stimulated by anodic polarization from the repassivated steel in the repaired zone*” [5]
- iii. “*If a structure with extensive chloride attack is to be patch repaired then it must be recognised that patching the corroding areas can accelerate corrosion elsewhere*” [7].
- iv. “*The repair of only those sites which are actively corroding in a chloride-contaminated structure is likely to stimulate corrosion at sites adjacent to the repair. This phenomenon is known as the incipient anode, ring anode or halo effect*” [8].
- v. When “*an anode develops on reinforcing steel in concrete, particularly due to chloride attack, it provides “natural” cathodic protection to the adjacent steel.*” When this anodic site is repaired it “*allows the previously “naturally cathodically protected” adjacent areas to start corroding*” [9].

As indicated by the above citations, a widely held view is that the cause of incipient anodes is the loss of the natural cathodic protection provided by the corroding steel to the steel in the parent concrete adjacent to the patch repair. Some works suggest that repairing concrete structures can accelerate corrosion damage elsewhere. This may be true. The incipient anode phenomenon is shown in Figure 1. This is a photo of a car park deck with a quilt like appearance resulting from successive patch repairs. However publications suggesting any other diagnosis for this phenomenon that exclude macrocell activity are scarce.

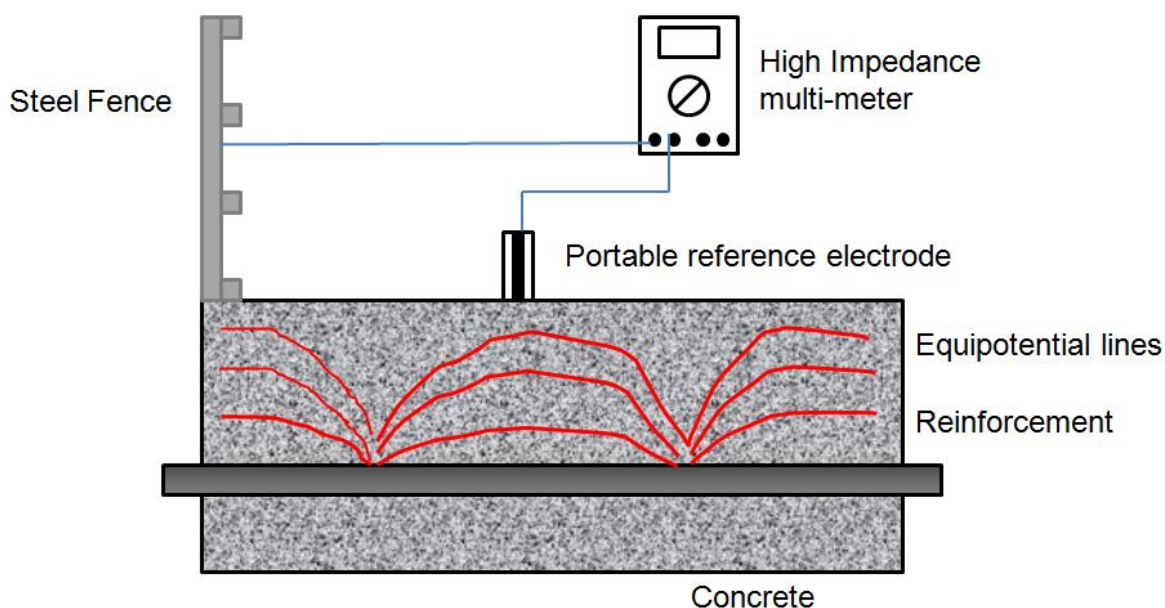

Figure 1: A concrete deck showing the quilt-like appearance associated with the incipient anode phenomenon arising from successive repair contracts.

The aim of the work presented here was to assess the impact of macrocell activity on the formation of incipient anodes around the perimeter of repairs in patch-repaired reinforced concrete structures. A multi-storey car park and a bridge, both constructed of reinforced concrete provided first-hand data, which is evaluated alongside data published previously by others [3]. The analysis challenges the view that macrocell activity is a cause of incipient anode formation. Indeed this work shows that the data supporting the existing diagnosis is not convincing and suggests that macrocell activity is primarily a consequence of incipient anode formation and the cause probably, results from other factors.

2 METHODOLOGY

2.1 STRUCTURES

The incipient anode phenomenon was discovered on site structures and is not generally observed in laboratory experiments. Thus the specimens on which data were obtained in this work were a multi-storey reinforced concrete car park in the East Midlands, UK and a 180m long multi-span reinforced concrete bridge in North Scotland, UK. Both structures were approximately 40 years old. The structural arrangement of the car park was a one-way spanning ribbed slab. The 80 mm thick slab was lightly reinforced with 8mm steel mesh. The 180 m long reinforced concrete bridge comprising 18 spans, had steel piles capped with reinforced concrete capping beams, supporting longitudinal prestressed concrete beams with a concrete infill deck.

Both structures suffered extensive corrosion-induced damage resulting from reinforcement corrosion. Both structures were exposed to de-icing salts in winter months. The bridge structure was also exposed to a marine environment. In the case of the car park, deteriorated elements included the reinforced concrete decks, parapets and deck soffits adjacent to leaking expansion joints. In the case of the bridge structure, the deteriorated elements included the reinforced concrete pile caps and the prestressed concrete beams.

All areas of concrete deterioration were repaired by removing damaged concrete by jack hammer on the car park and hydro-demolition on the bridge, cleaning the steel using rotary steel wire brushes and restoring the profile with proprietary cementitious materials. Several concrete repairs were monitored for the formation of macrocells and incipient anodes.

By studying site structures we gain valuable insights into incipient anode phenomena affecting such structures. The data may then be compared with previously published laboratory data that was used to support the existing diagnosis for the incipient anode phenomenon.

2.2 MATERIALS

Three proprietary repair materials, labelled A, B and C in this work were used to restore the concrete profile. All the materials are widely used in the construction industry and comply with existing standards [10]. Materials A and B were produced by the same manufacturer, material C was produced by another manufacturer. The nature of commercial contracts and their risk allocation require that a contractor uses specialist repair materials conforming to a standard. Because of the nature of this study it is not possible to give an equivalent material detail to that provided in laboratory experiments.

Material A is a Portland cement based, flowable, polymer modified, shrinkage compensated micro-concrete. 25 kg of material is mixed with 2.50 litres of water. It is placed directly into the repair area then trowel finished. It is mainly used for deck repairs and repairs involving shuttering. Material B is a Portland cement based, polymer modified, shrinkage compensated repair mortar with silica fume. The material is placed by dry spraying with a water to cement ratio of 0.35 to 0.4, and then trowel finished. It is used for repairs with large surface areas. Material C is a magnesia-phosphate cement based, non-shrink, repair mortar. 25 kg of material is mixed with 1.50 litres of water. Like material A, it is placed directly into the repair area and trowel finished. It is mainly used for deck repairs requiring very high early strengths. All of the materials are certified as class R4 repair mortars in accordance with BS EN 1504-3 [11].

The repair materials are tailored for the specific requirements of a repair area. Table 1 provides a summary of the monitored areas where each material was used.

Material	Structure type	Repair location
A	car park	Deck
B	Bridge	Soffits and vertical faces
C	Bridge	Deck

Table 1: Repair materials and location

2.3 TESTING

2.3.1 Chloride profiles

For the car park, historical chloride data were available for a large number of locations over the period 1997 to 2008. For the reinforced concrete bridge, 27 dust samples were taken from the prestressed concrete beams and from the reinforced concrete pile caps, at depths between 25 mm to 125 mm in 25 mm increments. The chloride content was determined by an independent laboratory in accordance with the current standards [12].

2.3.2 Carbonation

Concrete samples taken from the areas of repair were tested for carbonation. The samples were cleaned and tested in accordance with the current standard using the indicator phenolphthalein [13].

2.3.3 Potential mapping

The performance of the repairs was assessed by means of concrete surface potential mapping [14 – 16]. Potential maps were obtained on a 50 mm square grid to detect macrocell activity. Typically the steel potential was measured against the potential of a portable reference electrode (Ag/AgCl/0.5M KCl) using a high impedance multi-meter. When a direct steel connection was not possible relative measurements were taken to determine the change in the potential within the concrete as previously described [15]. In some cases the potential values are reported relative to the reference electrode, while in other cases they are reported relative to the most positive value obtained at the time of the measurement. This is indicated in the Figures.

3 RESULTS

3.1 MULTI-STOREY CAR PARK

The available chloride data for the car park exceeded the suggested limit of 0.3% by weight of cement [17] at the depth of the steel at 85% of the locations tested. No significant carbonation (less than 5mm) was identified on the concrete decks of the car park. The parapets were carbonated beyond the reinforcement at all areas tested. No data from the parapets is reported in this work because carbonation has a dramatic effect on pH and therefore potential. Only chloride induced corrosion damage was considered.

The steel potential after 30 days as a function of distance across a concrete surface that included a repair with material A is shown in Figure 2. It is clear that the potentials of the steel within the repaired area are substantially more negative than the potential of the steel in the parent concrete.

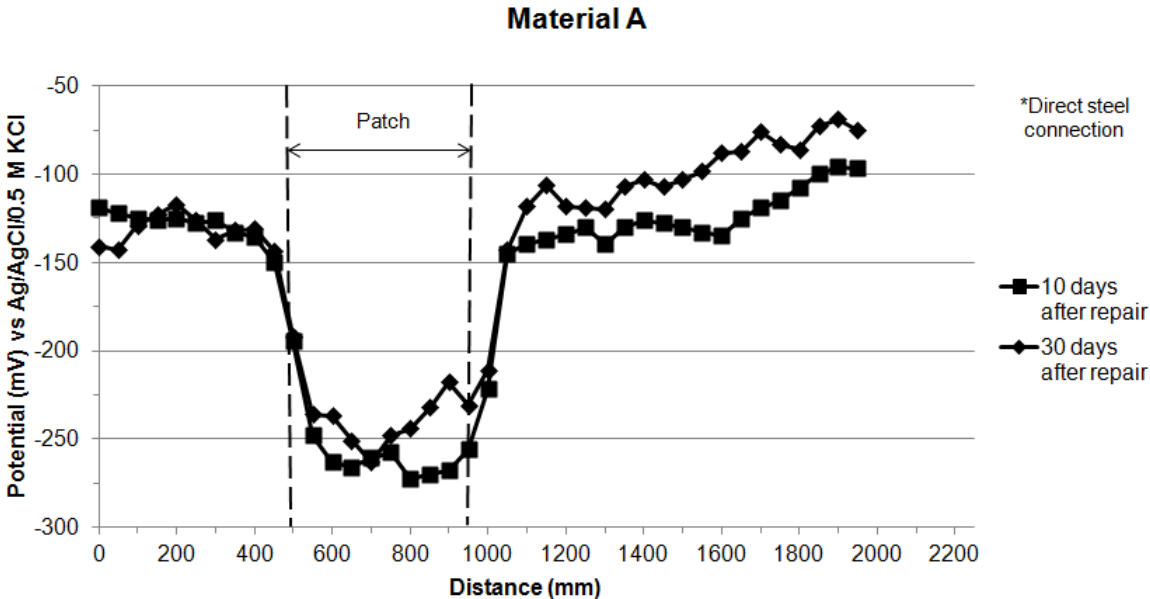
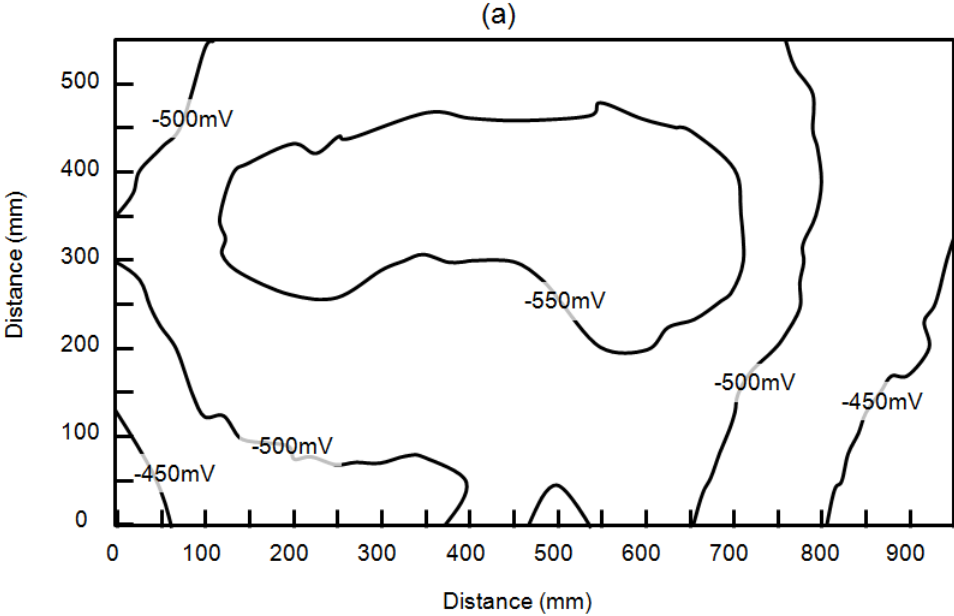

Figure 2: Potential mapping monitoring of material type A on car park deck repair

Contour plots showing potential mapping results both before and after repairing an area of corrosion damage with material A are given in Figure 3. The repair material had cured for 30 days when the data for the post repair contour plot was recorded. It is evident that, before the repair (Figure 3(a)), the potential in the area of the corroding steel was about 100 mV more negative than the potential in the adjacent parent concrete. 30 Days after the repair this difference increased to approximately 200 mV.



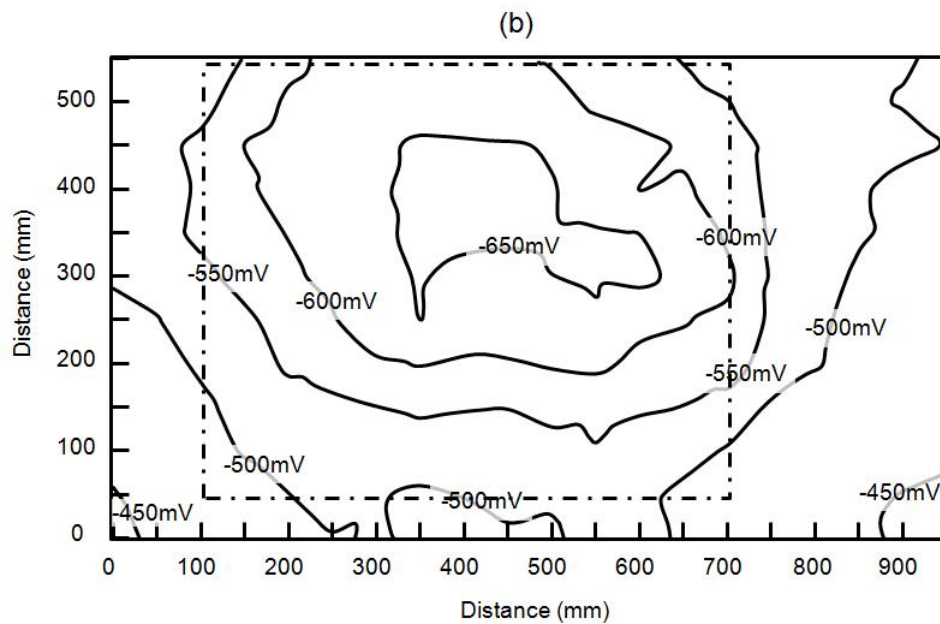

Figure 3: Surface potential mapping on car park repair (a) before and (b) 30 days after repair. Dashed line in (b) illustrates extent of patch repair.

Figure 4 shows the change in the potential difference between an area repaired with material A and the adjacent parent concrete over a period of 246 days. The early age results (15 days) show that the potentials within the patch repair were about 200 mV more negative than the potentials in the parent concrete. This difference reduced with time but the changes were relatively small. After 246 days the potential difference was somewhere between 150 and 200 mV. The potentials were measured in a variety of naturally occurring conditions including a very wet day on day 88.

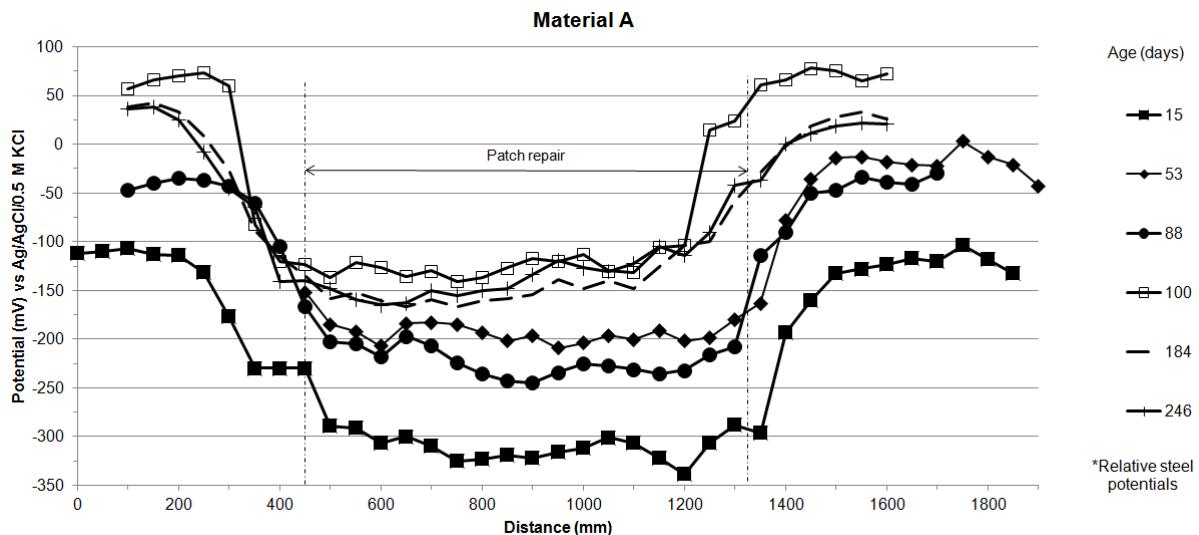

Figure 4: Surface potential mapping (a) before the repair and (b) 30 days after patch repairing with material A

3.2 BRIDGE STRUCTURE

Of the 27 samples for chloride analysis from the prestressed concrete beams and reinforced concrete pile caps, (taken at depths of 25 mm to 125 mm at 25 mm increments) only one was

below the suggested chloride limit of 0.3% by weight of cement [17]. Chloride levels of up to 1.89% by weight of cement were identified in the depth band of 75-100mm. Carbonation depths on the reinforced concrete pile caps and the prestressed concrete beams of the bridge were insignificant (approximately 5mm) and they did not reach the depth of the reinforcement. Thus only the case of chloride-induced corrosion was considered on the bridge structure.

The potential data obtained on patch repairs on the bridge structure illustrated similar behaviour to that obtained on the car park. Figure 5 shows data obtained at an area repaired with material B. The potentials of the steel within the repair material were about 200 mV more negative than the potentials of the steel in the adjacent parent concrete at the start. After 83 days the change was still greater than 100 mV.

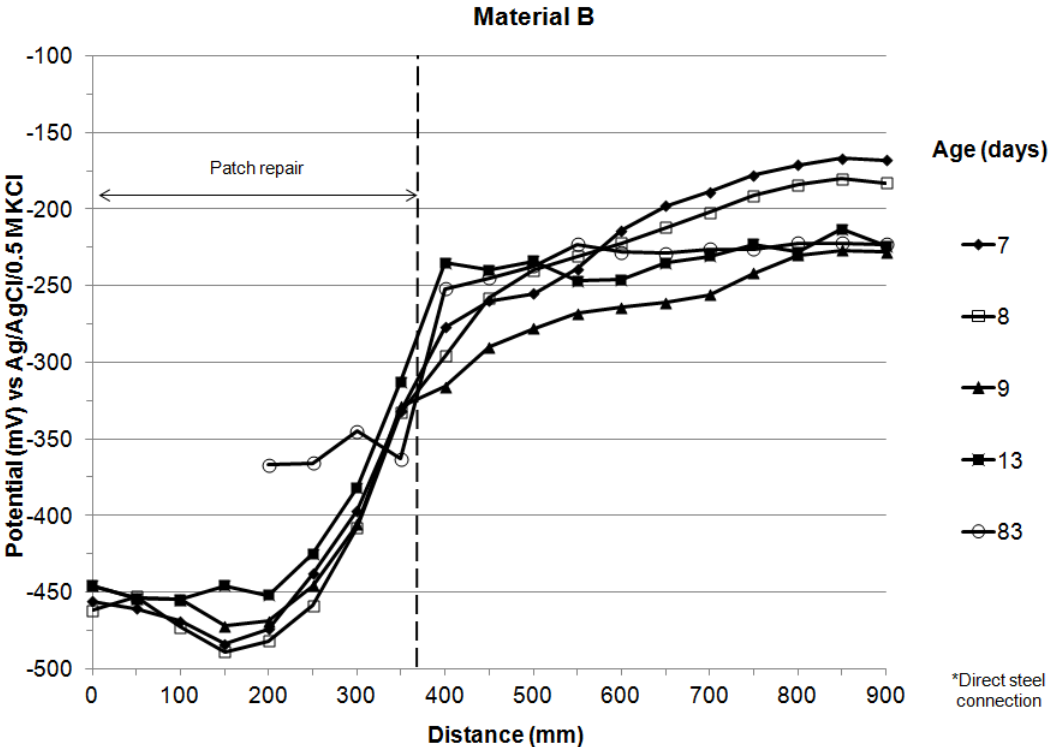

Figure 5: Potential mapping monitoring of material type B on a bridge repair

Figure 6 shows the steel potentials within the repair area measured before and after repair with material C. The data again shows that the potential of the steel within the repair area may be depressed to values that are more negative than the values observed in the parent concrete.

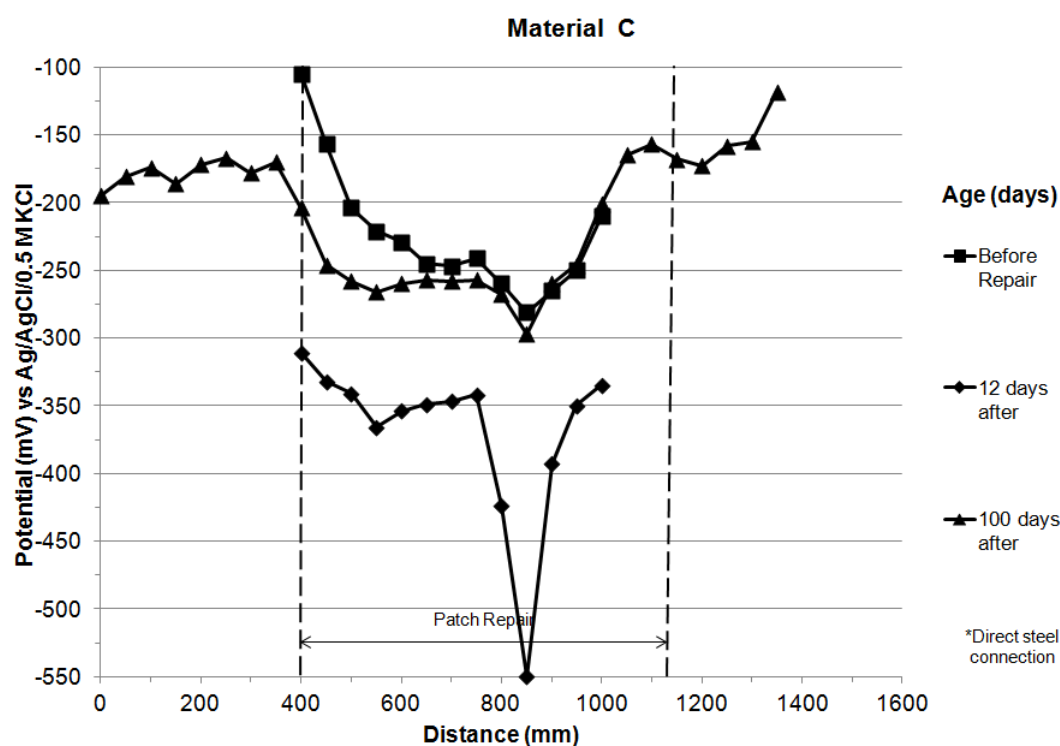

Figure 6: Potential mapping monitoring of material type D on a bridge repair

In some areas repaired with the pourable materials A and C, cracks were observed at the visible interface between the parent concrete and the repair material (Figure 7). The full extent of a crack is usually concealed due to the trowel finish of the repair that extends over to the parent concrete. It was only uncovered following surface preparation by mechanically shot-blasting in preparation for an applied coating. For the spray applied material B, no cracks were identified.



Figure 7: Cracks at the interface of a patch repair in the car park using material A, before and after surface preparation with mechanical shot-blasting

4 DISCUSSION

This discussion firstly considers whether the available data suggests that macrocell activity is a cause or a consequence of incipient anode formation. Factors affecting the potential that may have a bearing on the analysis are then considered. The repair material interface and

other factors that may induce incipient anode activity are then described and finally the corrosion risk resulting from repairing chloride induced corrosion damage is summarised.

4.1 CAUSE OR CONSEQUENCE

Figure 8 illustrates three possible cases schematically showing the steel potential change between repair material and parent concrete in the situation where a repair has been performed to address chloride-induced corrosion damage. The effect of an incipient anode on the steel potential in the parent concrete adjacent to the repair is taken into account in the potential plot in cases 1 and 2.

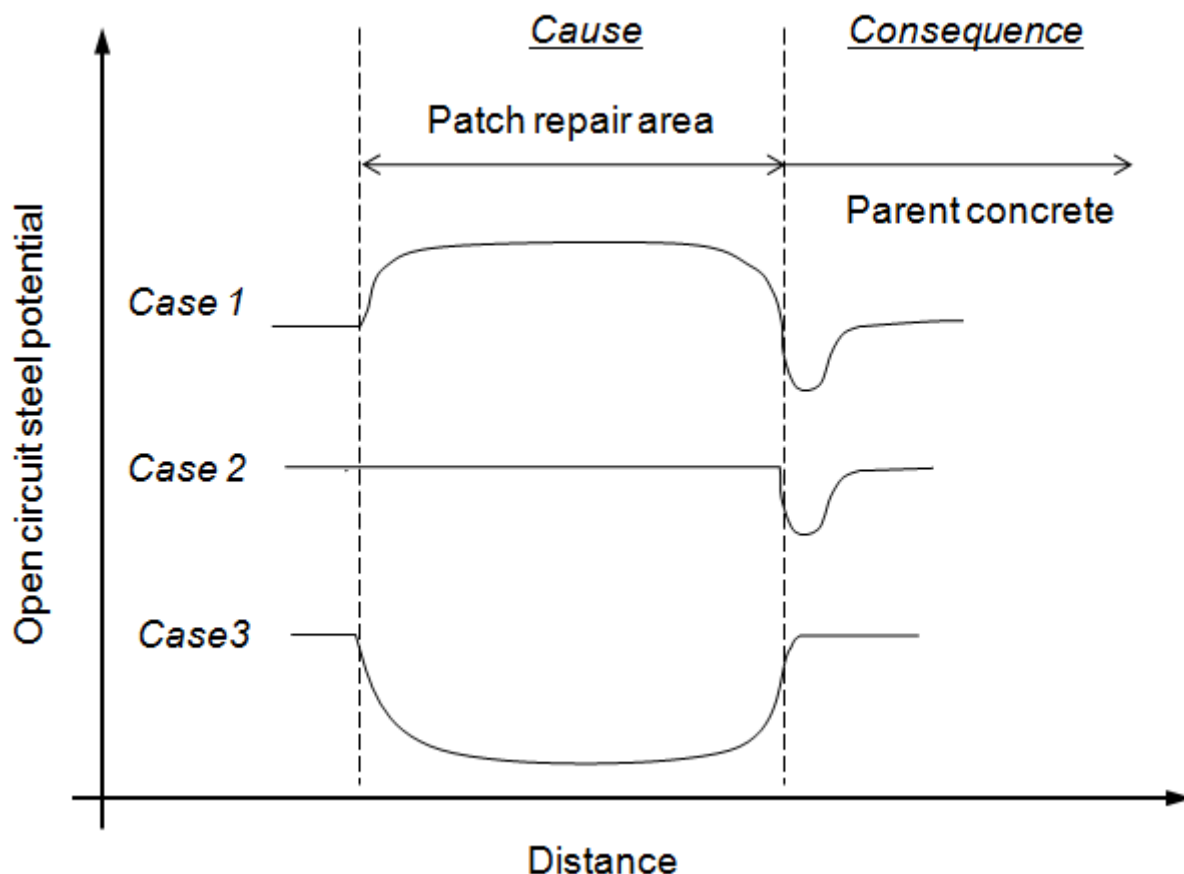

Figure 8: Three cases of potential changes between parent and repair concrete

Case 1 represents one textbook understanding of the cause of incipient anode formation [3, 5, 7, 8, 9]. In this hypothesis, the steel within the repair passivates as a result of the alkalinity of the fresh repair material, the absence of chlorides and the abundance of dissolved oxygen in the pore solution of the freshly mixed concrete or repair mortar. The steel potential in the repair rises above the passive steel potential in the parent concrete resulting in a macrocell that induces passive film breakdown causing an incipient anode to form adjacent to the repair. No data was uncovered either in the measurements recorded within this study or a review of the literature to support this hypothesis.

Case 2 represents the situation where the repair results in the removal of the corrosion site that used to be an anode. Previously published laboratory data [3] has shown that this situation may occur. Figure 9 reproduces the best data available supporting the widely held diagnosis (challenged in this current work) that macrocell activity causes incipient anode formation. To

obtain this data a concrete slab was cast and then repaired under laboratory conditions. The parent concrete was not aged in the same way that concrete on a structure is aged and a proprietary repair material conforming to existing standards was not used to repair the damage.

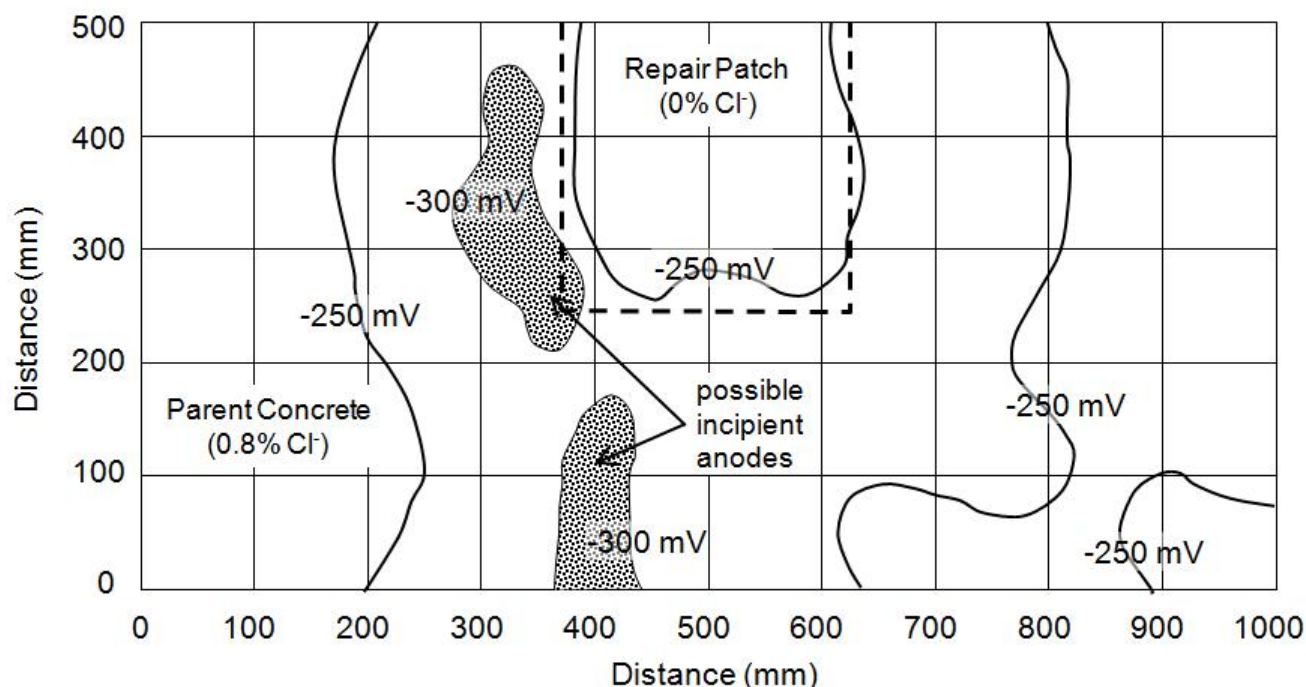

Figure 9: Open circuit steel potentials of a slab following 2 months of conventional patch repair (potential vs Standard Calomel Electrode) [3].

Figure 9 shows that the potential of the steel in the repaired area did not differ substantially from the potential of the steel in the parent concrete. Two possible areas of incipient anode formation were identified. Only one of these was located adjacent to the repair area. A macrocell was also present between steel in different areas of the parent concrete in Figure 9. This data does not show that the incipient anodes were stimulated by the formation of a new macrocell. The parent concrete already contained passive steel that was as positive as the steel in the repaired area. The data suggests that the residual chloride content was sufficient on its own to cause corrosion at least one of the identified areas of incipient anode formation.

Some natural cathodic protection that may have been provided by a previously corroding area of steel to its adjacent steel was removed in the repair process, but it is unlikely that this would cause any accelerated deterioration within the parent concrete. Indeed, the benefit provided by cathodic protection delivered from a corroding steel anode in concrete is questionable because corrosion of a steel anode results in expansive products that cause disruption to the surrounding concrete [18 – 19]. Reinforcement corrosion tends to spread laterally along the steel bars in conditions that also result in expansive corrosion products and the areas that receive the most protection from a corroding steel bar are the next areas to start corroding [20]. Thus, it is likely that a corroding steel anode causes more damage than it prevents and the removal of such an anode in the repair process should, in theory, slow the deterioration process if the deterioration was dominated by macrocell activity.

A related observation has been made with reference to the influence of a macrocell caused by coupling stainless steel to carbon steel in concrete. The impact of a stainless steel/carbon

steel couple on inducing corrosion on the carbon steel has been reported to be no different to that of a passive carbon steel/carbon steel couple and did not increase the corrosion damage reported on the carbon steel [21 – 23]. By the same argument, it is unlikely that a macrocell formed by coupling the steel in the repair area to steel in the parent concrete will have any substantial impact on inducing additional corrosion on the steel in the parent concrete.

Case 3 in Figure 8 represents the findings of our study on two full-scale reinforced concrete structures, after being patched with three proprietary repair materials. The steel potential in the patch was always more negative than the steel potential in the parent concrete over the period of time tested (Figures 2 to 6). While the measurements were obtained on real structures made with different concretes repaired using different proprietary repair materials that were exposed to a variety of environmental conditions and subject to many other unknown variables associated with repair contracts, there was not a single instance where the potential within the repaired area rose to or above that in the parent concrete.

Such an observation is not unique and has also been made by Cleland et al. [24] over a period of 2 years and by Morgan [25] when testing proprietary repair materials under laboratory conditions. These results support the hypothesis that, on balance, macrocell activity is a consequence, not a cause, of incipient anode formation in repaired concrete structures.

4.2 FACTORS AFFECTING POTENTIALS

Factors affecting the measured steel potential in a repaired area include passive film formation, pH, membrane effects and oxygen availability.

The steel passive film has to form on the steel in the repaired area and this will take time. However, the formation of the passive oxide film should have been complete after at least some of the periods tested, and should no longer have been affecting the potential within the repaired area. Thus, the formation of the passive film may only impart some limited time dependence to the potentials within the repaired area.

The pH of the environment has a strong impact on equilibrium potentials with a higher pH resulting in more negative equilibrium potentials. An increase in pH by just one pH unit in the alkaline region found within concrete will result in a 60 mV negative shift in both the equilibrium potential between iron and its products and the equilibrium potentials for the oxygen and hydrogen reactions [26]. Fresh repair concrete may well have a higher pH than aged concrete because the reaction between hydroxide and silica within the concrete or between hydroxide and carbon dioxide in the air will tend to reduce the pore solution pH in aged concrete to that sustained by one of the more abundant solid phases of cement hydration [27].

The change in pH between the repair material and the parent concrete can give rise to a membrane (or streaming) potential between the parent and the repair material [28]. This is due to diffusion of hydroxide ions from the repair material to the parent concrete and a charge on the walls of the pore system in concrete [29]. A charge on the pore walls results from incongruent dissolution of the solid phase and produces a membrane. The effect of the charge results in positive and negative ions diffusing at very different rates through the pore system and the movement of such ions in response to a concentration gradient induces the membrane potential. Studies on membrane potentials in concrete suggest that large membrane potential

effects are transient, i.e. they diminish with time [30]. Furthermore, membrane potentials in excess of 100 mV seem unlikely [31]. In many cases the potential differences observed in the present work exceeded 100 mV.

Passivity and oxygen availability affect the anodic and cathodic kinetics. Oxygen is consumed to passivate the steel in the repaired area. Many proprietary repair materials have a low permeability that restricts oxygen access and increases resistance. Thus Morgan [25] concluded that the use of polymer, styrene butadiene or acrylic modified cement mortars with such properties did not affect corrosion of steel in adjacent unrepaired areas. The effects of pH and permeability also suggest that any macrocell activity between parent concrete and proprietary repair materials will have less effect than macrocell activity that resides exclusively within the parent concrete.

Membrane potentials and formation of the passive oxide film probably give rise to some of the time dependence. However, they do not dominate the time dependence to the extent that steel potentials in the repaired areas rise above that in the parent concrete. The data from this study, like that of Cleland et al. [24] and Morgan [25] provided no evidence to indicate that macrocell activity is a cause of incipient anode formation in aged concrete structures repaired with proprietary repair materials.

4.3 REPAIR MATERIAL INTERFACE

Cracks may occur at the interface between the parent concrete and the repair material following patch repair. The presence of such cracks can be attributed to drying, or plastic shrinkage, thermal or stiffness incompatibility, poor curing, surface preparation or a combination of the above [32]. Admixtures can be used to increase the volume of the repair material during early age hardening of shrinkage compensated materials. However, the material will often undergo an S-shaped expansion-contraction cycle [33]. Although close to zero net unrestrained shrinkage can be achieved in such shrinkage compensated materials, there may be some limited retained shrinkage which can give rise to cracking because the early expansion part of the cycle is restrained by the parent concrete.

Chadwick [34] examined the corrosion protection afforded by single cast, cast in two halves and patch repaired specimens. He observed a major reduction in the corrosion protection for the latter two types of specimens and suggested that it is not necessary for chlorides to be present in the parent concrete for incipient anodes to form at the interface. He suggested that it is only necessary to expose the repaired concrete element to a chloride-contaminated environment, as the interface between the two concrete or mortar materials provides easier access for chloride penetration.

Thus, the interface between repair material and parent concrete may provide a path for chlorides to penetrate preferentially into the substrate. The extent of this effect will be dependent on surface preparation, application techniques, curing, material properties and compatibility with the parent concrete. The presence of visible cracks may be obscured by trowel finishing the repair.

Crack formation in reinforced concrete structures and its relationship to corrosion has been established by a number of studies [35, 36]. In particular, it has been shown that the reinforcement within and around the crack zone will start to corrode first. Chadwick [34] also

observed that the presence of construction joints in the same material resulted in corrosion initiating at lower apparent chloride levels at the construction joint interface.

4.4 INCIPIENT ANODE FORMATION

The repair of corroding areas removes the anode in this location and any “sacrificial” cathodic protection effects resulting from such anode. However, it is very unlikely that simply turning a corroding steel anode into a passive cathode would result in more damage occurring than if nothing was done [20, 21]. Other factors associated with the repair process that might cause incipient anodes to form include repair material interface effects, residual chloride contamination and damage to the steel-concrete interface during repair preparation.

Cracks and interfacial effects between parent concrete and repair material provide an easier path for the chlorides to penetrate into the substrate. The parent concrete may have a higher permeability than the new repair material and this will aid the diffusion process from the interface into the parent concrete. The parent concrete is also likely to have some residual chloride contamination that may promote corrosion. The preparation of the repair area usually requires the mechanical removal of concrete that puts a lot of energy into the steel reinforcement. This may cause damage to (or defects at) the interface between the unexposed steel and the parent concrete adjacent to the repair area. Such defects increase the corrosion risk by lowering the chloride threshold level [27].

4.5 CORROSION RISK

This analysis has suggested that there is no obvious increase in corrosion risk following patch repair of reinforced concrete structures that results from macrocell activity, beyond what would be the case if the steel had remained passive (i.e. there is no increase in the macrocell voltage). Indeed, steel reinforcement in an aged parent concrete may remain cathodic relative to steel in proprietary repair materials for a substantial period after the repair is undertaken. The results of this study are in line with previously reported findings by Bertolini et al. [21] and Qian et al. [22] on the corrosion risk presented by a galvanic couple of stainless steel to carbon steel. The damage caused by a corroding steel anode in an unrepaired area probably outweighs any electrochemical protective effects that such a corroding area may deliver [20, 21].

Incipient anodes may form around patch repairs and their presence can be detected with potential mapping. As noted above, alternative causes of incipient anodes include a permeable interface between the parent and repair materials, residual chloride contamination of the parent concrete and damage to the steel interface within the parent concrete during the preparation of the repair area.

The results of this research help to inform the development of corrosion management strategies that may include rehabilitation methods such as cathodic protection, surface coatings and hydrophobic impregnations, to increase durability of reinforced concrete structures.

5 CONCLUSIONS

- i) While the incipient anode phenomenon often occurs on repaired reinforced concrete structures, potential measurements taken on structures repaired with a variety of proprietary repair mortars over a period of up to 250 days suggest that macrocell activity does not stimulate incipient anode formation. No evidence was found from potential measurement data obtained in this work to support the diagnosis that macrocell activity is a cause of incipient anode formation. The evidence suggests the detrimental effect of a corroding steel anode in concrete outweighs any beneficial effects that were provided previously by such an anode. In other words, a corroding steel anode causes more damage than it prevents.
- ii) The use of proprietary repair materials may permanently depress steel potentials within the repair area. The reasons for this include the typically low permeability and high pH of these materials. A high pH in an area of repair would result in a negative shift in steel potentials because equilibrium potentials of steel in concrete are more negative at the high end of the pH range. Macrocell activity that might be damaging is less likely to occur between parent and repair concrete than within the parent concrete.
- iii) Cracks can develop at the repair/substrate interface, even with shrinkage-compensated repair materials, providing an easier path for chlorides to penetrate into the substrate. This cracking results from their “S” shaped strain curve so that, even in an unrestrained case (where no net strain occurs) shrinkage occurs in the final phase. The extent of these cracks will be dependent on surface preparation, application techniques, material properties, adhesion between the repair material and parent concrete and curing conditions. Such cracks may be obscured by trowel finishing of the repair.
- iv) The diagnosis of the cause of the incipient anode phenomenon adjacent to areas of concrete repair may reside in one or more of the following reasons:
 - a. Chlorides may enter the concrete through the interface between the parent and repair material,
 - b. the parent concrete adjacent to the repair area may have an above average level of residual chloride contamination that is sufficient on its own to cause corrosion, and/or
 - c. preparation of a repair area may result in vibration damage at the steel interface with the adjacent parent concrete.

ACKNOWLEDGEMENTS

The authors would like to thank AECOM and the EPSRC (through the Centre for Innovative and Collaborative Engineering at Loughborough University) for their commercial and financial support.

6 REFERENCES

[1] M. Dugarte A.A. Sagiüés, Galvanic point anodes for extending the service life of patched areas upon reinforced concrete bridge members, Contract No. BD544-09, Final Report to Florida Department of Transportation, Tampa, Florida, USA, September 2009.

- [2] C. Christodoulou, G. Glass, J. Webb, S. Austin, C. Goodier, A new approach for the patch repair of car parks using galvanic anodes, *Concrete Solutions 2011*, 4th International Conference on Concrete Repair, 26-28 September 2011, Dresden, Germany, ISBN 978-0-203-13468-9.
- [3] C.L. Page, G. Sergi, Developments in cathodic protection applied to reinforced concrete, *J. Mater. Civ. Eng.* 1 (2000) 8-15.
- [4] S. Qian, J. Zhang, D. Qu D, Theoretical and experimental study of microcell and macrocell corrosion in patch repairs of concrete structures, *Cem. Concr. Compos.* 28 (2006) 685 – 695.
- [5] L. Bertolini, B. Elsener, P. Pedferri, R. Polder, *Corrosion of steel in concrete, prevention, diagnosis, repair*, Wiley-VCH, Germany, 2004.
- [6] C.L. Page, K.W.J. Treadaway, Aspects of the electrochemistry of steel in concrete, *Nature* 297, (1982) 109-115.
- [7] J.P. Broomfield, *Corrosion of steel in concrete: understanding, investigation and repair*, 2nd ed., Taylor and Francis, UK, 2007.
- [8] Concrete Society, Technical Report 73, *Cathodic Protection of Steel in Concrete*, Surrey, UK, 2011.
- [9] British Standards Institution, BS EN ISO 12696:2012, *Cathodic protection of steel in concrete*, London, BSI, 2012.
- [10] Concrete Society, Technical Report 69, *Repair of concrete structures with reference to BS EN 1504*, Surrey, UK, 2009.
- [11] British Standards Institution, BS EN 1504:2005 *Products and systems for the protection and repair of concrete structures — Definitions, requirements, quality control and evaluation of conformity — Part 3: Structural and non-structural repair*, London, BSI, 2005.
- [12] British Standards Institution, BS 1881–124:1988 *Testing concrete, Methods for analysis of hardened concrete*, London, BSI, 1988.
- [13] British Standards Institution, BS EN 14630:2006 *Products and systems for the protection and repair of concrete structures — Test methods — Determination of carbonation depth in hardened concrete by the phenolphthalein method*, London, BSI, 2006.
- [14] Concrete Society, Technical Report 60, *Electrochemical tests for reinforcement corrosion*, Surrey, UK, 2004.
- [15] G. K. Glass, N. Davison, A. C. Roberts, *Monitoring Method*, UK Patent GB 2449039 B, 2010.
- [16] C. Christodoulou, G. Glass, J. Webb, S. Austin, C. Goodier, Assessing the long term benefits of Impressed Current Cathodic Protection, *Corros. Sci.* 52 (2010) 2671 – 2679, DOI: 10.1016/j.corsci.2010.04.018
- [17] *Design Manual for Road and Bridges, Volume 3, Section 3, Part BA 35/1990 Inspection and Repair of Concrete Highway Structures*, Departmental Standard, UK, 1990.
- [18] K. Lau, A.A. Sagüés, *Corrosion of steel in locally deficient concrete*, Contract No. BD544-31, Final Report to Florida Department of Transportation, Tampa, Florida, USA, February 2009.
- [19] Y. Zhao, J. Yu, Y. Wu, W. Jin, Critical thickness of rust layer at inner and out surface cracking of concrete cover in reinforced concrete structures, *Corros. Sci.* 59 (2012) 316 – 323.
- [20] G K Glass, N Davison, A C Roberts, Hybrid corrosion protection of chloride-contaminated concrete, *Proceedings of the Institution of Civil Engineers, Constr. Mater.* 161 (2008) 163 – 172
- [21] L. Bertolini, M. Gastaldi, M.P. Pedferri, P. Pedferri, T. Pastore, *Proceedings of the International Conference on Corrosion and Rehabilitation of Reinforced Concrete Structures*, Orlando, USA, 1998.

-
- [22] S. Qian, D. Qu, G. Coates, Galvanic coupling between carbon steel and stainless steel reinforcements, *Can. Metall. Q.* 45 (2006) 475-484.
- [23] C.M. Abreu, M.J. Cristobal, M.F. Montemor, X.R. Nova, G. Pena, M.C. Perez., Galvanic coupling between carbon steel and austenitic stainless steel in alkaline media, *Electrochim. Acta* 47 (2002) 2271 – 2279.
- [24] D.J. Cleland, K.M. Yeoh, A.E. Long, Corrosion of reinforcement in concrete repair, *Constr. Build. Mater.* 11 (1997) 233 – 238.
- [25] D.R. Morgan, Compatibility of concrete repair materials and systems, *Constr. Build. Mater.* 10 (1996) 57 – 67.
- [26] M. Pourbaix, Thermodynamics and corrosion, *Corros. Sci.* 30 (1990) 963 – 988.
- [27] G.K. Glass, B. Reddy L.A. Clark, Making reinforced concrete immune from chloride corrosion, *Proceedings of the Institution of Civil Engineers, Constr. Mater.* 160 (2007) 155 – 164.
- [28] Y. Schiegg, M. Büchler, M. Brem, Potential mapping technique for the detection of corrosion in reinforced concrete structures: Investigation of parameters influencing the measurement and determination of the reliability of the method, *Mat. and Corr.* 60 (2009) 79–86.
- [29] G. K. Glass, N. R. Buenfeld, Chloride-induced corrosion of steel in concrete, *Prog. Struct. Engng. Mater.* 2 (2000) 448 – 458.
- [30] J.L. Marriaga, P. Claisse, Effect of the non-linear membrane potential on the migration of ionic species in concrete, *Electrochim. Acta* 54 (2009) 2761-2769.
- [31] U. Angst, Ø. Vennesland, R. Myrdal, Diffusion potentials as source of error in electrochemical measurements in concrete, *Mat. and Struct.* 42 (2009) 365-375.
- [32] Concrete Society, Technical Report 22, Non-structural cracks in concrete, Surrey, UK, 2010.
- [33] K. Szilágyi, I. Zsigovics, C. Szautner, Advanced shrinkage compensation of concretes by a combined admixture system, *Építőanyag* 59 (2007).
- [34] R. Chadwick, Performance of concrete repair materials as corrosion protection for reinforcement, PhD thesis, University of Surrey, 1993.
- [35] M. Raupach, Chloride-induced macrocell corrosion of steel in concrete – theoretical, background and practical consequences, *Constr. Build. Mater.* 10 (1996) 329 – 338.
- [36] P. Schiessl, M. Raupach, Laboratory studies and calculations on the influence of crack width on chloride-induced corrosion of steel in concrete, *ACI Mater. J.* 94 (1997) 56-62.

[This page is left intentionally blank]

APPENDIX C PAPER 2

Full Reference

Christodoulou C, Glass G, Webb J, Austin S and Goodier C, Assessing the long term benefits of Impressed Current Cathodic Protection, *Corrosion Science*, 52 (2010), pp. 2671 – 2679
DOI information: 10.1016/j.corsci.2010.04.018

Abstract

This experimental field study interrupted the protection current offered by Impressed Current Cathodic Protection (ICCP) to ten in-service reinforced concrete structures. The study aimed to identify the long term effects of ICCP after it was recognised that some of the systems are now reaching the end of their design life and require a significant level of maintenance. It was found that after five or more years of ICCP, the steel remained passive for at least 24 months after interrupting the protection current despite chloride contamination that would represent a corrosion risk.

Keywords – Steel Reinforced Concrete, Polarization, Cathodic Protection, Passivity, Pitting Corrosion, Repassivation

Paper type – Journal

1 INTRODUCTION

ICCP of atmospherically exposed steel reinforced concrete structures has been used since 1970s and it is a proven technique which is able to arrest ongoing corrosion and induce and sustain steel passivity [1]. The main principle of cathodic protection is applying an impressed current such as to induce negative steel polarisation [2], in other words to drive the steel potentials more cathodically than -850 mV (SCE), where corrosion process is thermodynamically impossible to occur [3]. Under these conditions the steel will be immune to corrosion.

However, for atmospherically exposed reinforced concrete, changing the environment from actively corroding (i.e. pitting) to passive, where pitting is unstable will be sufficient. Steel protection has been attributed to the negative potential shift achieved from the impressed current [4] but it has also been reported that it also contributes to the production of hydroxyl ions, an increase of the pH and driving the chloride ions away from the steel – concrete interface [5].

It is widely accepted that the application of cathodic protection to a reinforced concrete structure transforms the environment around the reinforcement over a period of time [5]. The metal surface is now polarised negatively, thus repelling the chlorides (Cl^-); oxygen (O_2) and water (H_2O) are consumed and hydroxyl (OH^-) is generated at the metal surface. The hydroxyl alkalinity will then be responsible for restoring the pH to the metal surface and inducing passivity of the metal.

Evidence suggests that after steel passivity has been restored then the protection current may be interrupted, as illustrated by Broomfield and Tinnea [6]. This study looked at steel potentials prior to the application of an ICCP system and compared them with the potentials after the structure was protected for approximately one year and the cathodic protection system turned off for three months. It was observed that the application of ICCP shifted the steel potentials towards more positive values.

A recent study was undertaken in the U.S.A. by Presuel-Moreno et. al [7] on the effect of long-term cathodic polarisation in reinforced concrete columns in a marine environment. The structures tested were partially submerged with the splash zone exposed to very high chloride contamination levels, in some cases up to 4.7 % by weight of cement and they had been protected by ICCP for an approximate period of 9 years. The study concentrated the testing on the splash zone and illustrated that corrosion did not initiate immediately after the current was interrupted. Some of the reinforcement was reported to start corroding again after approximately 35 days but even after the study was stopped at 220 days, not all the reinforcement was actively corroding at the time. It is also very interesting that steel passivation was achieved with current densities of $0.5 \mu\text{A}/\text{cm}^2$ ($5 \text{ mA}/\text{m}^2$). With reference to BS EN 12696 [2] such current density is considered to be on the lower spectrum of the suggested design current to achieve cathodic protection on actively corroding structures.

Although the above study concluded that given enough time the corrosion could initiate on all the reinforcement again, there is evidence from a very aggressive environment that ICCP has long-term persistent protective effects [7]. It is also supporting the experimental data presented in this paper, which was collected on a far less aggressive environment with

chloride levels not exceeding 2 % by weight of cement as opposed to the 4.7 % by weight of cement recorded in the U.S. field study.

In addition, there is a substantial amount of laboratory data obtained under more rigorous circumstances to support this observation of an increase in the tolerance to chloride contamination and the persistent protective effects. Figure 1 shows the results of a study in which a brief period of electrochemical treatment that would have generated hydroxide ions at the steel caused a substantial increase in the tolerance to chloride contamination [8]. The observation that electrochemically treated structures are more tolerant to chloride contamination is countered by an observation that in very heavily chloride contaminated concrete; corrosion may start again.

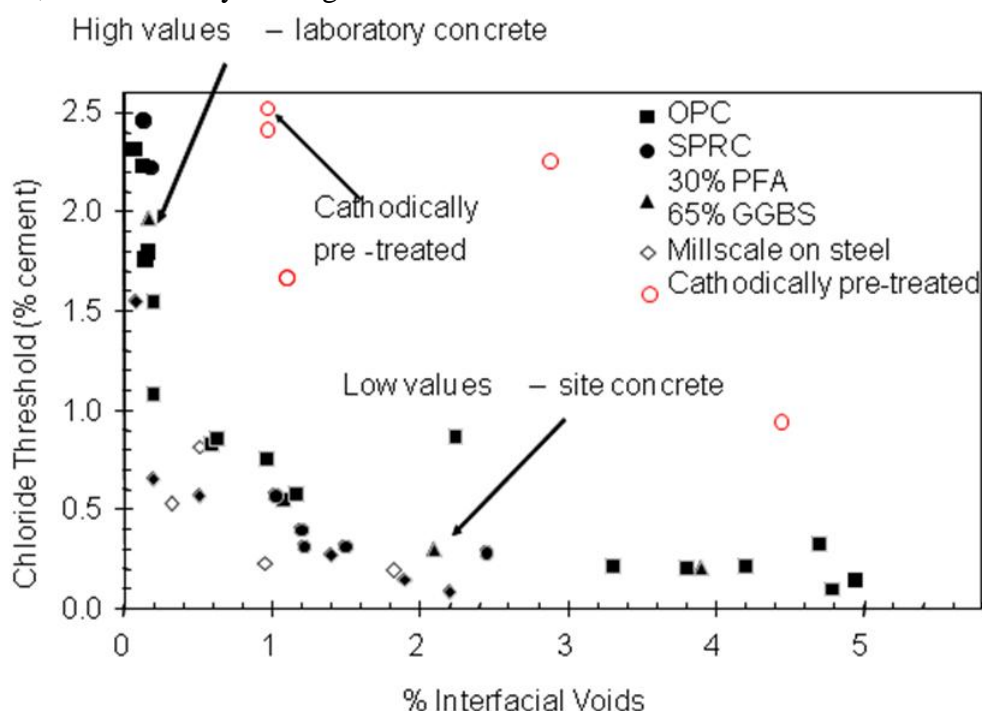

Figure 1: Effect of cathodic protection treatment on corrosion risk at high chloride contents [8]

The study aims to identify the existence of persistent protective effects afforded by the application of ICCP in a number of field structures. Midland Links Motorway Viaducts represents the largest application of ICCP in the U.K., with over 700 reinforced concrete structures being protected by cathodic protection. Data was collected from in service structures that can be compared in context of published laboratory data.

2 FIELD STUDY & METHODOLOGY

The following sections describe the field study by stating the location of the works, briefly describing the structures and their history and by analysing the selection methods used in order to obtain a representative sample of structures. Furthermore, the methodology used to assess corrosion risk is described and examples of technical calculations are also given.

2.1 STRUCTURES SELECTION

Figure 2, illustrates a typical arrangement of the sub-structure for the Midland Links Motorway Viaducts. Each span of the viaduct is simply supported on a reinforced concrete crossbeam. In total there are approximately 1200 crossbeams in the network and about 700 of them have been protected by means of ICCP over the last 20 years.

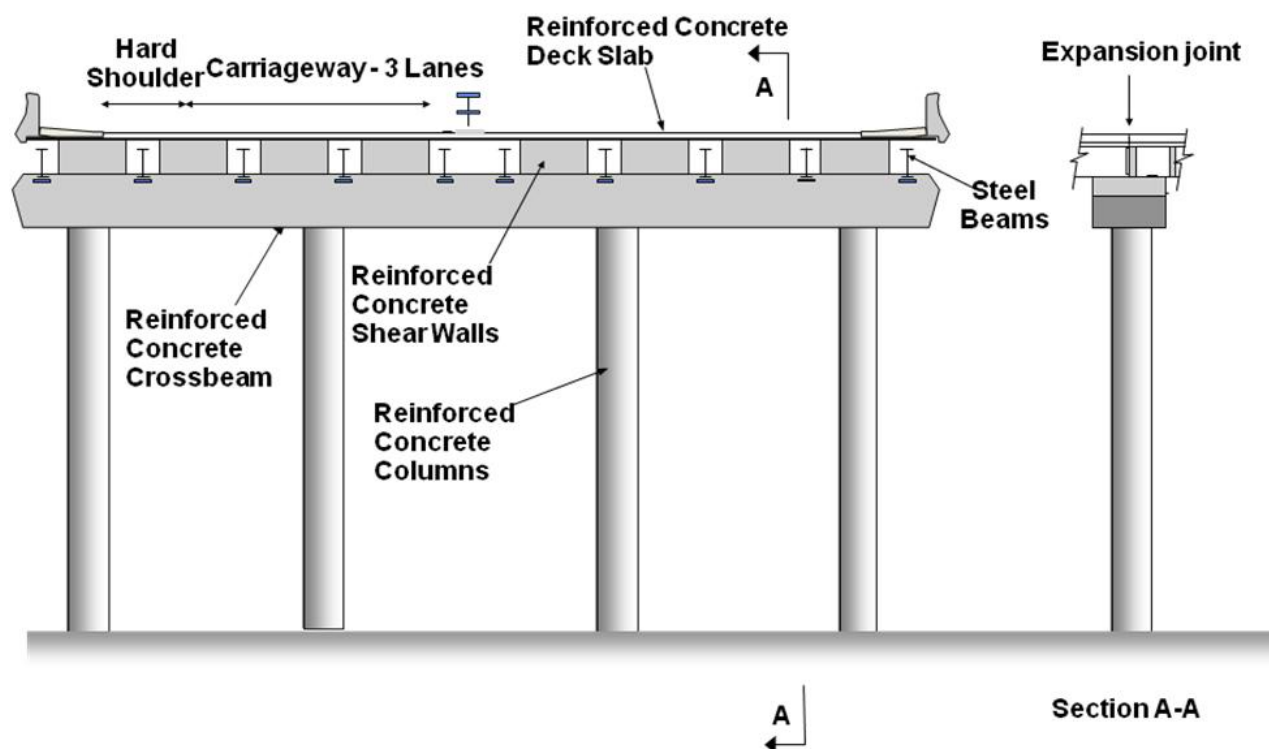

Figure 2: Typical sub-structure arrangement

The beams tested were selected in such an order to represent reinforced concrete with a high risk of chloride induced corrosion that had been subject to cathodic protection for a range of protection periods. A total of 10 beams were selected based on the age of the installed CP system, accessibility and chloride levels indicating a residual corrosion risk. On every beam two locations were selected for monitoring based on the chloride analysis to install anode segments, with the total number of monitored locations therefore being 20. Figure 3, illustrates one of the beams that were tested to assess the long-term benefits of ICCP. It is showing severe anode deterioration but no active corrosion.



Figure 3: Beam tested for long term effects of ICCP, showing evidence of severe anode deterioration but not signs of corrosion

The 10 beams that were selected are given in Table 1. All the structures were constructed in the period of 1966 to 1970. Samples for chloride analysis were collected to identify areas of residual risk. The locations of testing were in original un-repaired concrete and the chloride contents are expressed as weight percent of cement and for a 25 to 50 mm cover depth. No chloride contents above 2% by weight of cement were detected at this depth. All the structures were treated for a period of time with ICCP as illustrated by Table 1 and the anode system comprised a conductive coating. The structures selected have anode systems provided by different suppliers in order to also compare their performance.

Table 1: Details of the 10 selected structures.

Structure Reference	Year of Installation	Locations with Cl- greater than 1% by weight of cement	No of test locations	Locations with Cl- greater than 0.4% by weight of cement	Comments	Age of system (as of 2007)
A1	1991	2	4	4	24/7 data logger	12-16 yrs
A2	1995	2	5	3	-	
A3	1995	2	5	5	24/7 data logger	
B1	1996	3	6	4	-	9-11 yrs
B2	1998	1	5	4	-	
B3	1998	2	5	3	-	

B4	1998	2	5	3	-	
C1	1999	0	5	2	-	5-8 yrs
C2	2002	0	5	1	-	
C3	2000	0	5	1	-	

Note: Cl⁻ sampling at 25 mm to 50 mm

2.2 METHODS OF ASSESSMENT

In order to assess corrosion activity in the structures, a number of tests were undertaken, including:

1. Corrosion potential measurements, undertaken monthly and in some cases continuously
2. Polarisation resistance determination of corrosion rates, undertaken monthly to calculate corrosion rates
3. Impedance measurement of corrosion rates initiated after 6 months

Measuring steel potentials against the potentials of a standard reference electrode is a long established technique [9,10]. Typical ranges of steel potentials for various conditions against different types of reference electrodes are widely available in the public domain [10,11]. In accordance with BA 35/90 values more positive than -200 mV Cu/CuSO₄ (saturated) indicate a low probability of corrosion. Steel potentials can give a good approximation of the corrosion risk of steel but they are affected by various other factors [11].

Corrosion rates are usually expressed as a current density, a rate of weight loss or a rate of section loss. A corrosion rate of 1 mA/m² when expressed as a current density is approximately equal to a steel weight loss of 10 g/m²/year or a steel section loss of 1 µm/year. In general corrosion rates higher than 1 – 2 mA/m² are considered to be significant and in cases where there is easy access of oxygen (i.e. non-saturated with water) then average corrosion rates can reach values up to 100 mA/m² [12]. The calculation of corrosion rates through the polarisation resistance method is a well established technique and its feasibility has been demonstrated in numerous occasions [13,14,15,16].

Rates below 2 mA/m² (500 years to lose one mm of steel section) are considered negligible and corrosion development is highly unlikely. At a rate higher than the 2 mA/m² localised corrosion activity becomes increasingly likely. This results from the loss of protection provided by the passive oxide film and the concrete cover [17].

Figure 4, illustrates how corrosion rates are calculated based upon the applied current and the achieved potential shift. A small current density is applied to the steel for a period of 10 minutes. This produces a steel potential shift and a voltage drop (IR drop) through the concrete. The potential shift and applied current density are inserted into the Butler-Volmer equation, which provides the basis for polarisation resistance theory, to calculate the corrosion rate. There are several variations on this method, but this variation is more suited to the determination of corrosion rates in site conditions as it uses a larger potential shift and less

complex equipment than is commonly applied in the laboratory and makes use of the existing CP anode system as a guard electrode [18].

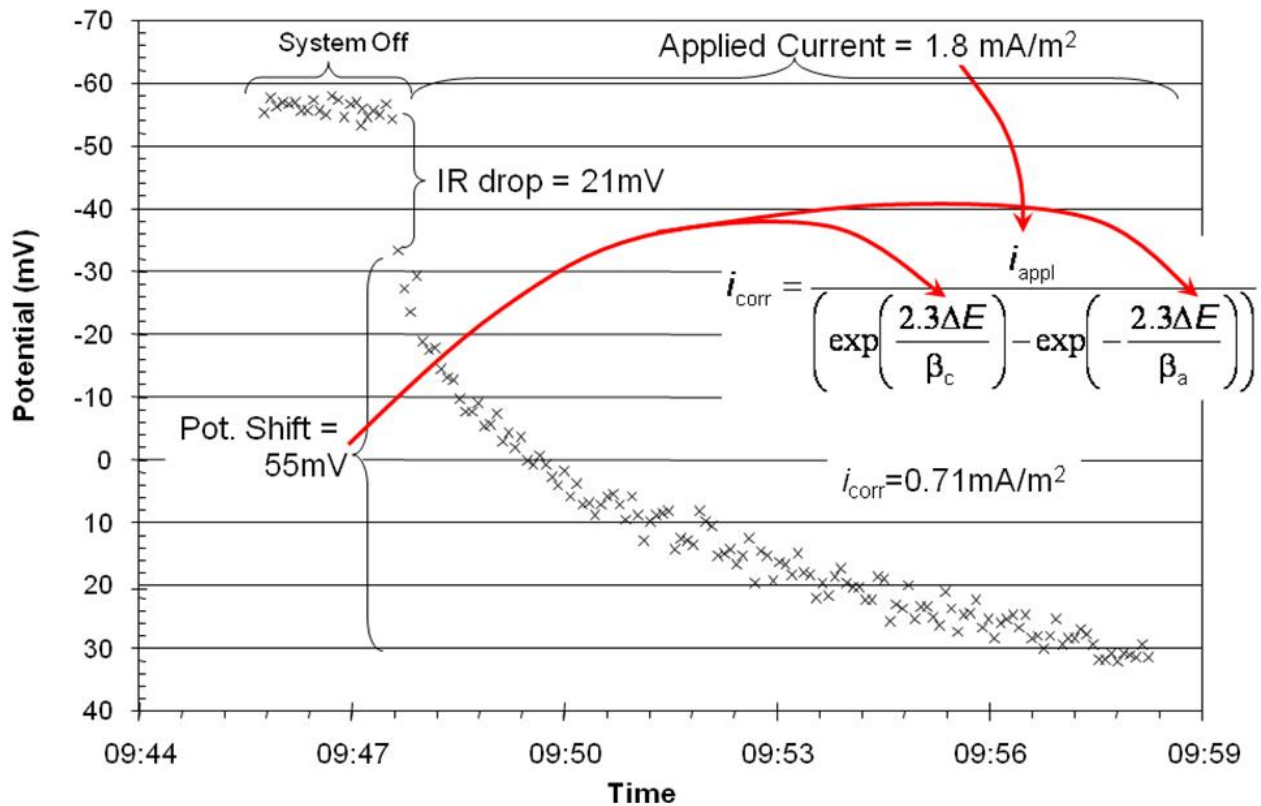

Figure 4: Example of a corrosion rate calculation

Impedance is an alternative technique to calculate corrosion rates and was added to the testing regime during this project to provide additional data. A short current pulse is applied to the structure and the potential shifts over a short period of time are recorded. The potential shift achieved and the time of the potential decay can then be associated with the corrosion rate of the structure [19].

Impedance testing differs from polarisation resistance testing in the form of the perturbation applied and the subsequent data analysis. A current pulse delivers a charge to the steel that affects the steel potential and the potential response is recorded and analysed.

2.3 TESTING ARRANGEMENT

The arrangement used to assess steel passivity is illustrated in Figure 5. Briefly the main elements were the existing power supply enclosure located at ground-level, the existing CP enclosure at high-level, the anode segment and a new enclosure at high-level to facilitate the new connections to the system.

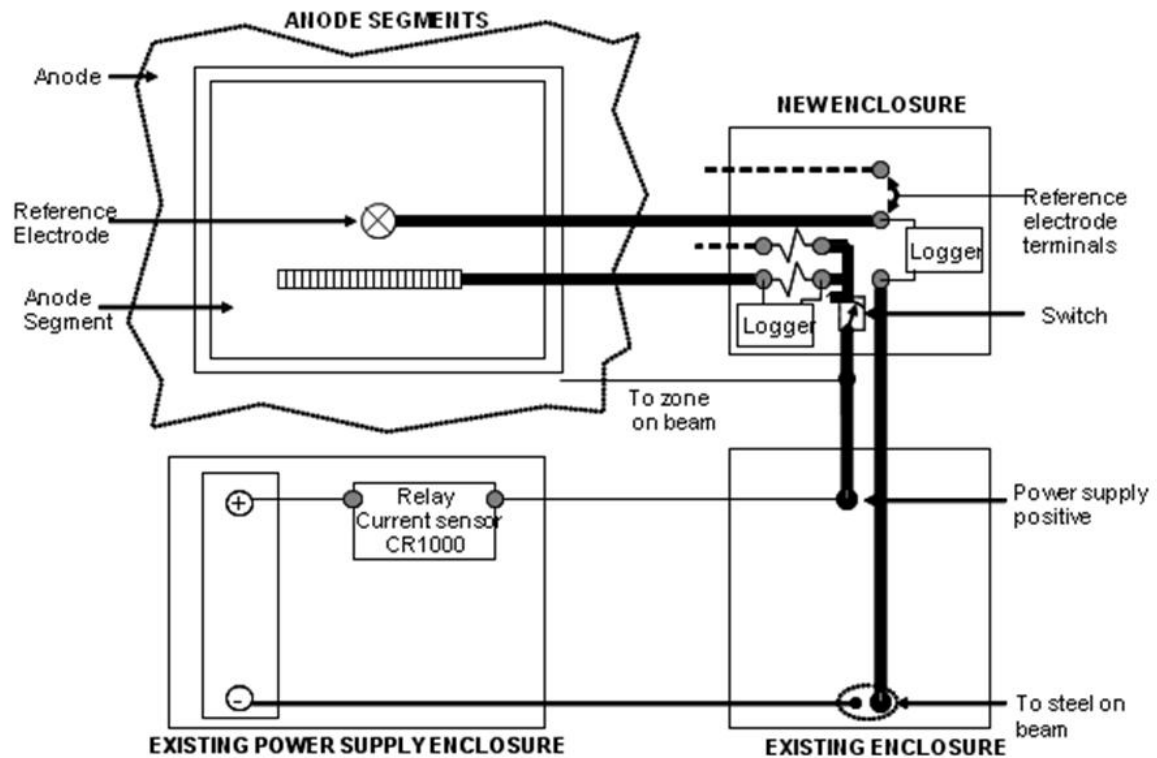

Figure 5: Testing arrangement

A segment of the anode (patch) approximately 0.35 m^2 was isolated from the rest of the anode system by removing the old anode. This isolated area was cleaned up and a new anode was installed locally and coloured black as shown in Figure 6. The existing anode segment acts as a counter electrode and the rest of the anode system acts as a guard ring to confine a current perturbation of the anode segment to the steel below the anode segment during the corrosion rate measurement process. A reference electrode located in the middle of the anode segment is used to assess the steel potential shift.

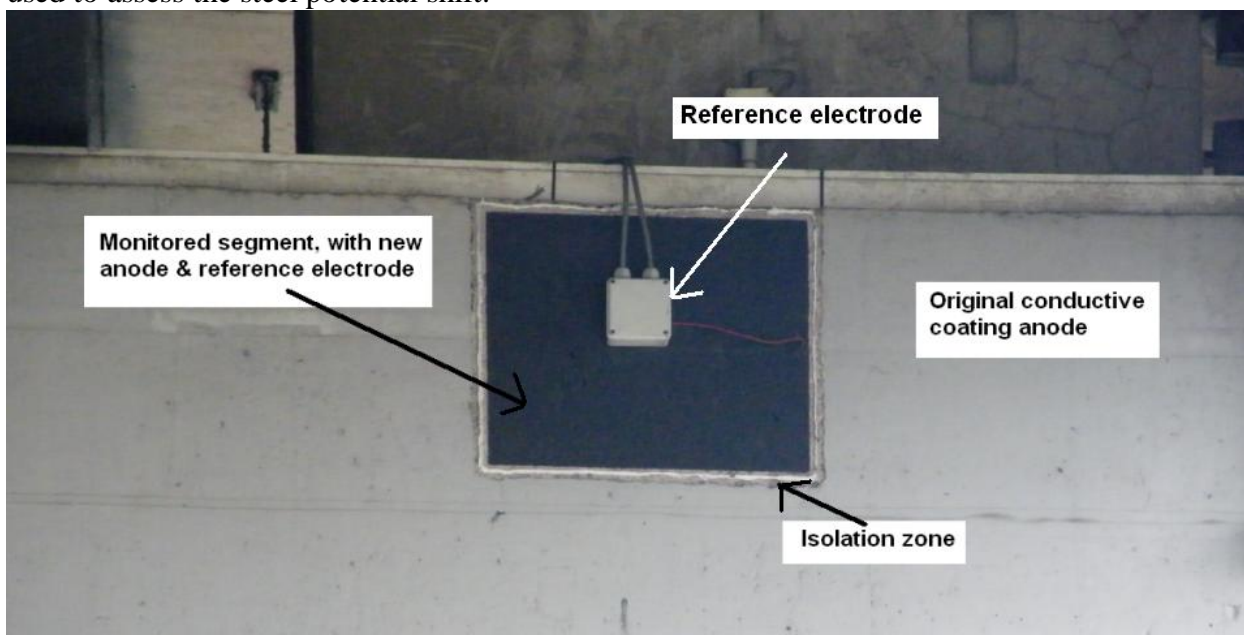

Figure 6: Isolated anode segment and reference electrode location

The new electrodes were installed in order to monitor high chloride concentration areas that were not previously monitored from the original electrodes installed during the installation of the ICCP system. All the new reference electrodes installed in the 10 beams were Ag/AgCl/0.5 M KCl, the same as the originally installed reference electrodes. The data was recorded using data loggers or recorded manually. The system was designed with the existing power supply providing the current perturbation. However, some of the existing supplies were unstable and a battery power supply was used for all measurements from the second month.

3 RESULTS

This section describes the findings obtained from the monthly monitoring of the structures over a period of 24 months and discusses in detail the findings.

3.1 CHLORIDE CONTENT

Samples for chloride analysis were collected at the start of the project. 5 locations were tested for every structure. The values referred to Table 1 correspond to chloride levels found at the depth of steel (i.e. 25 mm to 50 mm). The values express total chloride content by weight of cement. The test locations were all in the parent concrete not previously repaired, in order to identify residual corrosion risk. From Table 1 it can be observed that higher chloride contents were present in the older beams whereas in the recently repaired beams chloride levels did not exceed 1 % by weight of cement.

3.2 STEEL POTENTIALS

Figure 7, illustrates the most negative steel potentials for all 10 structures monitored for a period of 24 months with respect to the newly installed reference electrodes. In accordance with BA 35/90, values more positive than -200 mV Cu/CuSO₄ (saturated) which is equivalent to -120 mV (Ag/AgCl/0.5 M KCl), indicate a low probability corrosion risk. Values more negative than -270 mV (Ag/AgCl/0.5 M KCl) indicate a high corrosion risk. The values recorded during this study were in most cases more positive than -120 mV (Ag/AgCl/0.5 M KCl) and therefore the corrosion potential data suggests that corrosion risk is currently negligible on these structures.

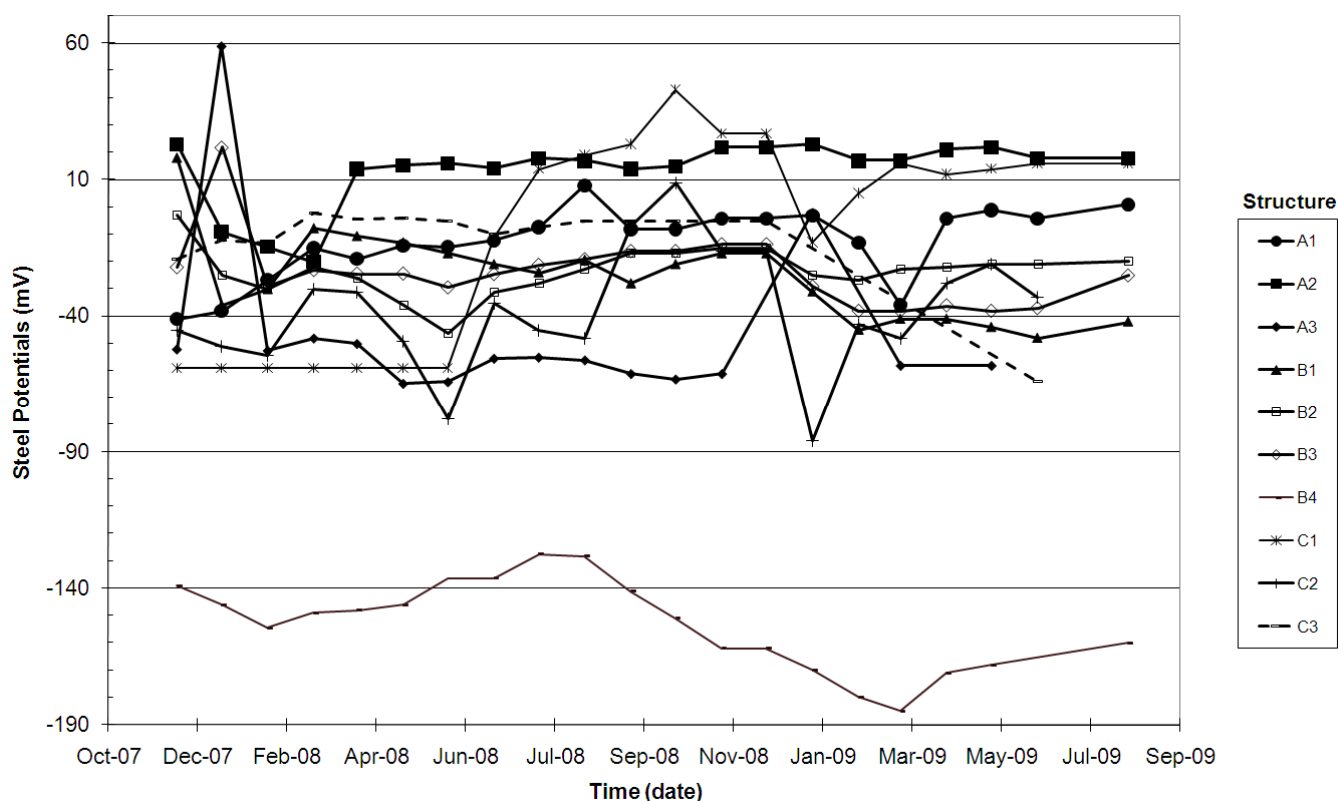

Figure 7: Steel potentials of the 10 structures monitored over a period of 24 months

Looking at the steel potentials of structure C2 from Figure 8, it can be observed that in most cases the original 11 (Ag/AgCl/0.5 M KCl) reference electrodes (installed on the crossbeam at the time the ICCP was installed) were more positive than -120 mV. The highs and lows observed are usually dependant on the weather conditions. Although the ambient conditions were not recorded as part of this study, the site notes indicate that in the majority of the occurrences parts of the crossbeam were very wet whereas other completely dry. The absence of a trend to more negative values indicates that the passive condition is stable.

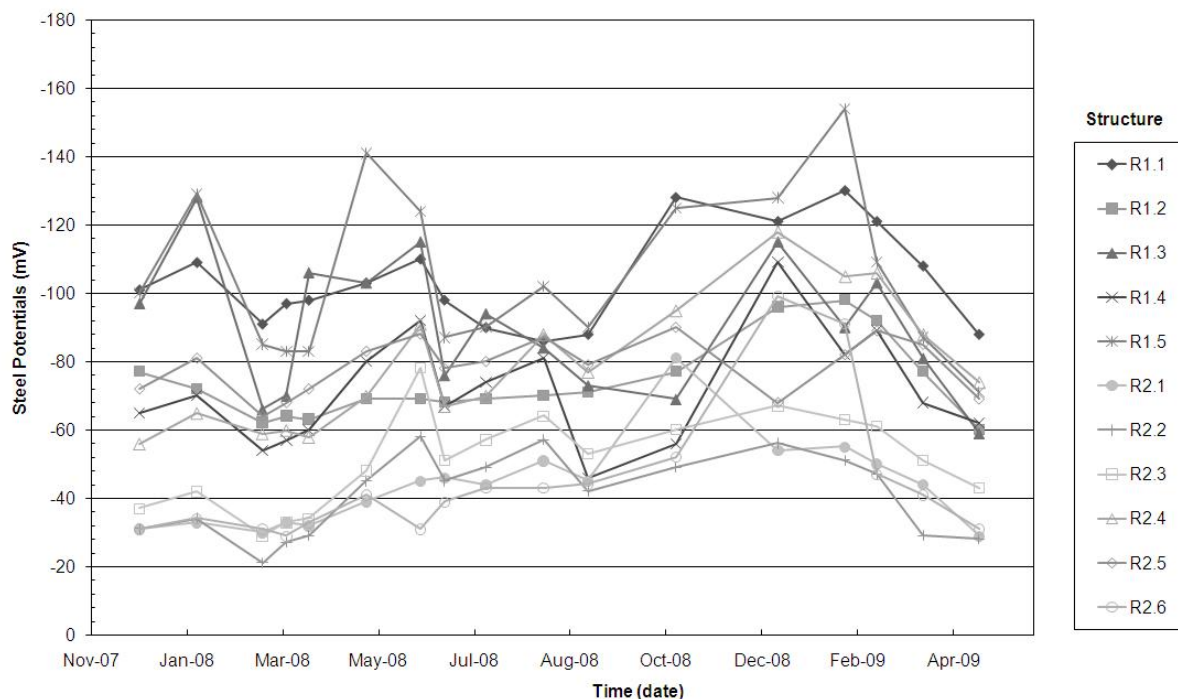

Figure 8: Steel potentials with respect to original reference electrodes for structure C2

Figure 9, illustrates steel potentials with regards to the Ag/AgCl/0.5 M KCl reference electrode for one of the segments obtained from the continuous monitoring of structure A1 over a period of seven days. The fluctuation of the readings is associated with changes in the environmental conditions (i.e. temperature, moisture, etc.) and indicate that there is no residual corrosion risk as the values are fairly positive.

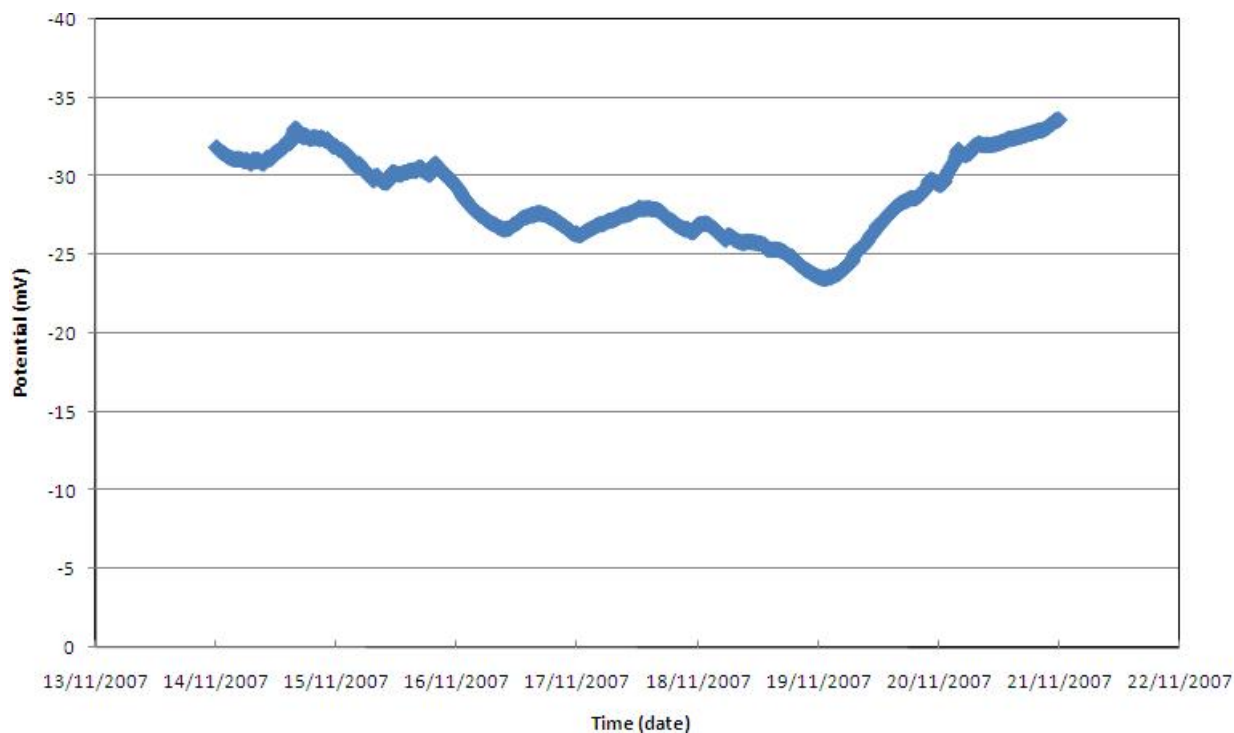

Figure 9: Steel potentials for structure A1 over a 7 day period

3.3 POLARISATION RESISTANCE TESTING

Manual polarisation resistance testing was undertaken monthly for every structure. Figure 10, illustrates potential data obtained from structure A3 during November 2007. Structure A3 was one of the two structures where a data logger was installed. The location of these loggers was based on the condition of the anode systems, accessibility and safety issues. The two structures selected were part of the early installations with one of them performing very well whereas the other one showed signs of severe anode deterioration. The data collected was very important as it offered a direct comparison between a failing and a very good performing system and both were installed with a small difference in time.

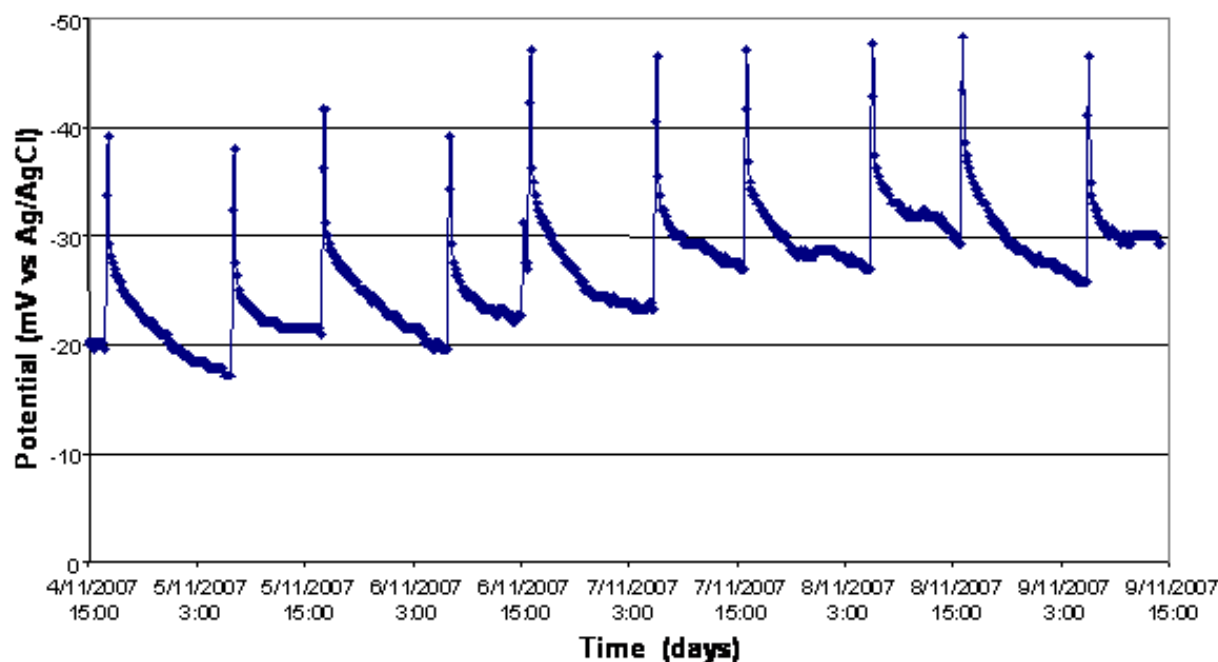

Figure 10: Potential data for structure reference A3, illustrating the long term effects of polarisation induced by a brief and low current density pulse

The installed data logger controlled the current output and the system was switched on for 20 minutes twice a day. During this period a current pulse was applied and the steel potentials were recorded. The readings obtained were used to evaluate the potential shift for corrosion rate measurements.

It was observed that a current of 2 mA/m^2 applied for 20 minutes induced a steel potential shift of 20 mV and affected the off potentials for more than 12 hours. This again shows that the steel is passive as such a large and slow response would not result if the corrosion rate (corrosion current) was large. The measurement of corrosion rates by means of polarisation resistance testing was actually producing a polarisation effect as indicated by the steel potential decay. Close interval automatic corrosion rate measurements were discontinued.

Figure 11, provides a summary of corrosion rates calculated from the manual polarisation resistance testing undertaken monthly on each structure. It can be observed that in all cases the corrosion rates were well below the threshold level of 2 mA/m^2 , reinforcing the view that cathodic protection will have persistent long-term effects. Occasional peaks can be observed

from the readings but these are primarily associated with the influence of galvanic currents as discussed before.

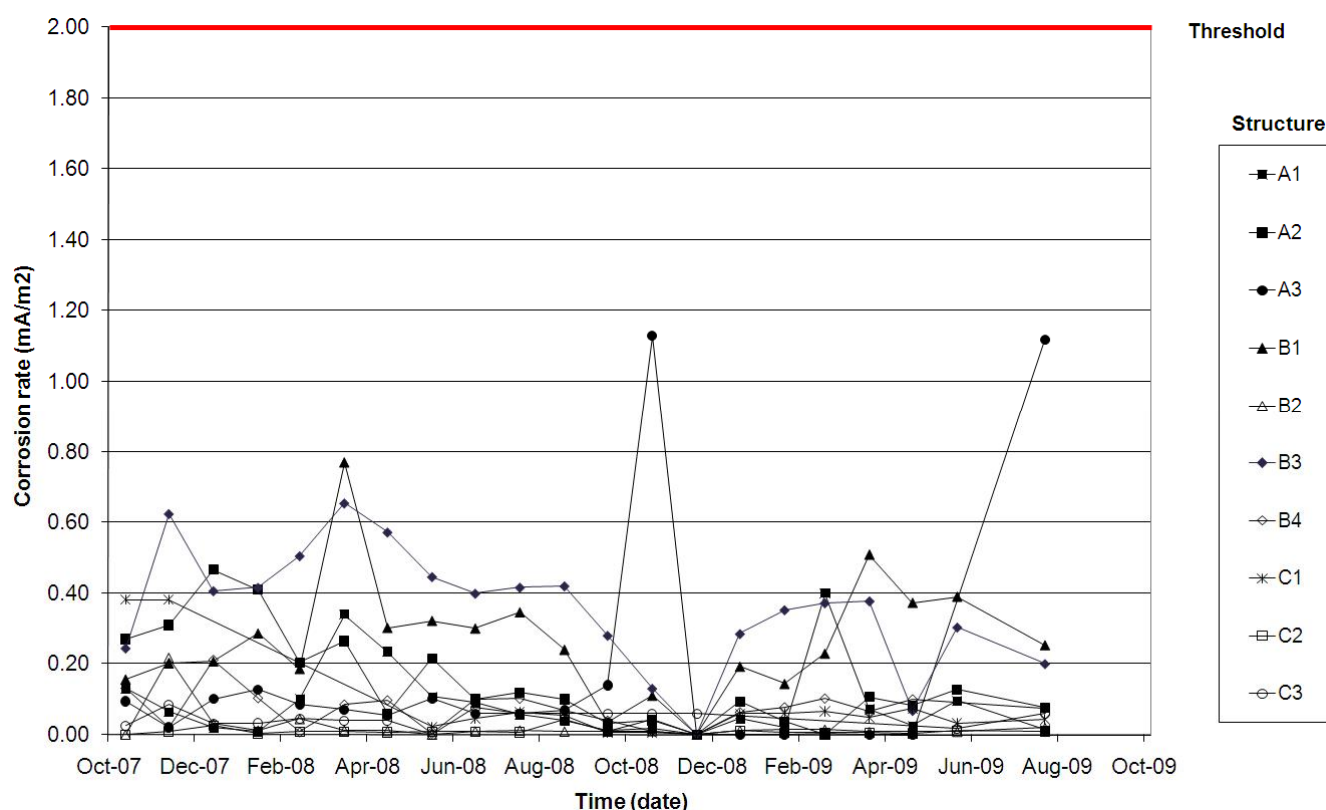

Figure 11: Corrosion rates summary from polarisation resistance testing over a period of 24 months.

3.4 IMPEDANCE TESTING

As discussed previously, for impedance testing a short pulse is applied and the potential decay is recorded. The current - time (current pulse) and potential - time (Figure 12) data are combined and transformed into impedance data (Figure 13). Impedance is a frequency dependent resistance that includes phase angle information. It is commonly plotted on an x-y graph. Each point on the graph is obtained at a different frequency and the data represents the magnitude of the resistance and phase angle at that frequency.

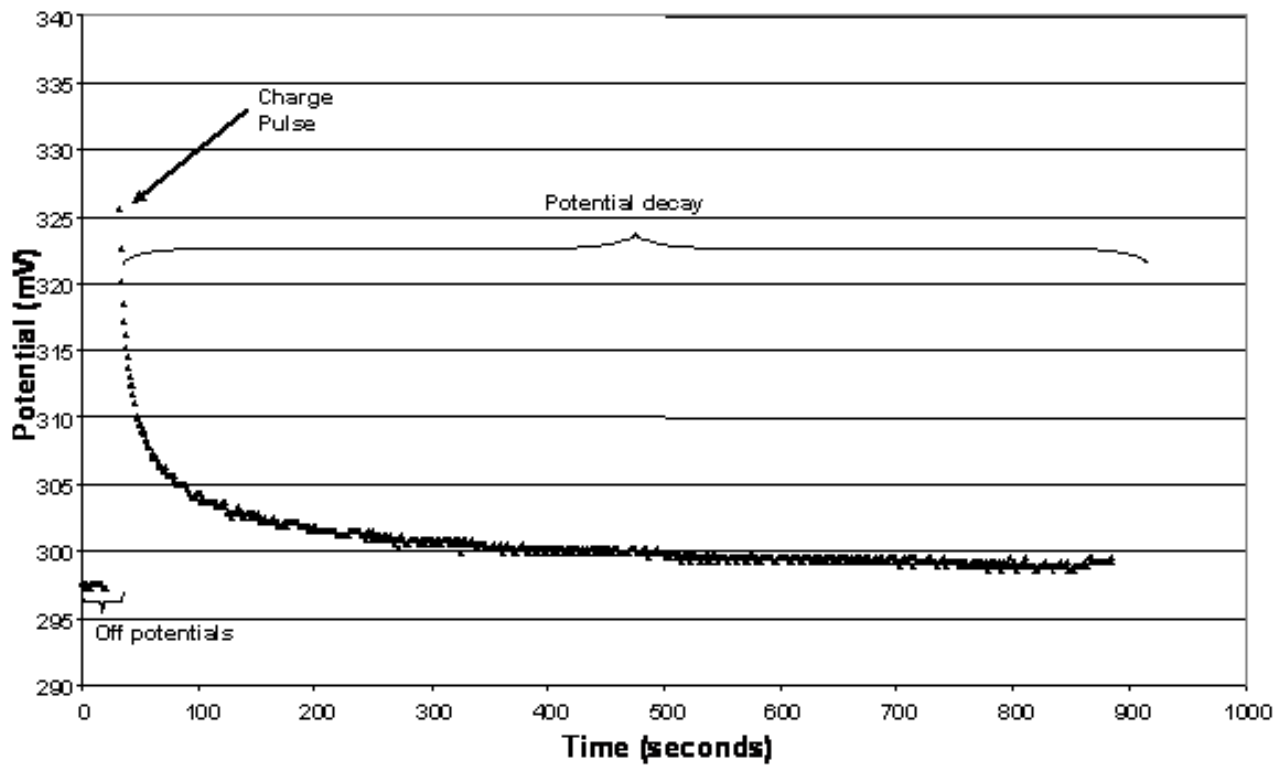

Figure 12: Raw data for impedance analysis for structure C3

The units on the axes in Figure 13 arise when potential is divided by current density and are also the units of polarisation resistance. The point at a phase angle of zero (the x-axis intercept) is the polarisation resistance (I_{corr}). The corrosion rate may be derived from this in the usual manner. The frequency at the peak of the curve is termed the characteristic frequency (f). It is affected by the condition of the steel and lower frequencies indicate a more intact passive film.

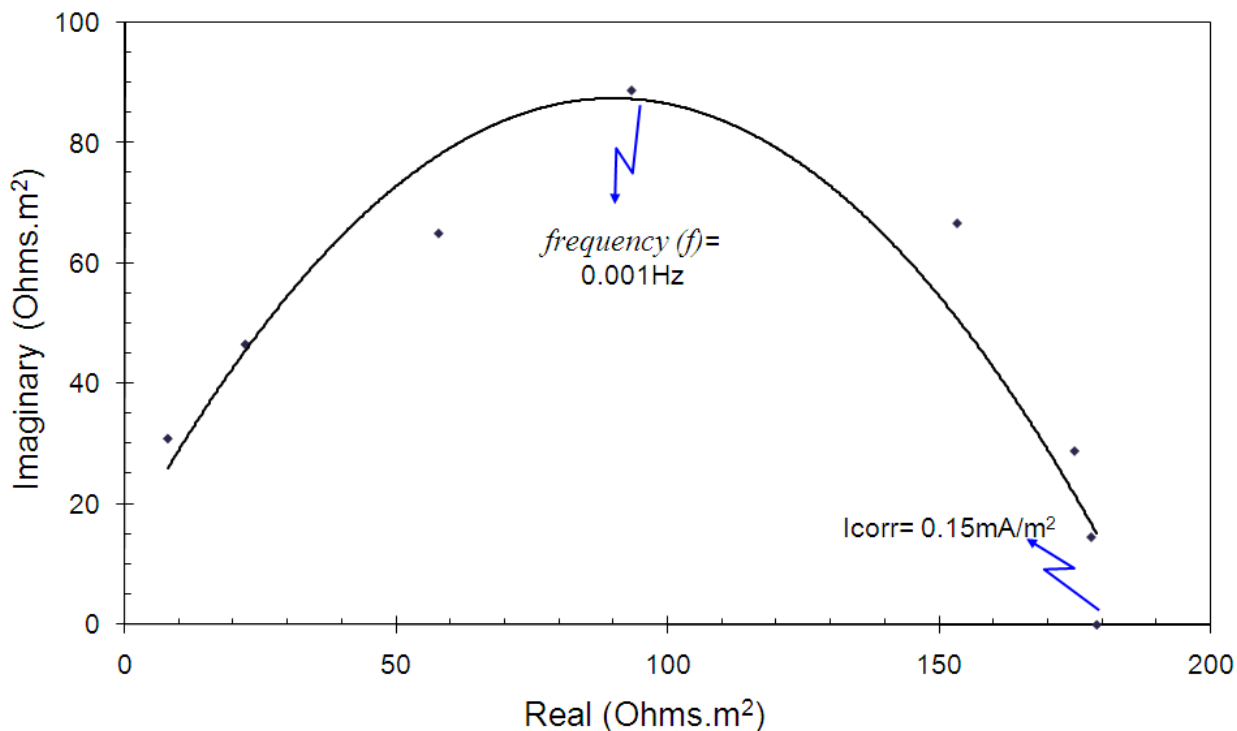

Figure 13: Analysis of raw data to obtain corrosion rate for structure C3

The data obtained for structure C3 (Figure 13) is compared with published laboratory data for active and passive specimens in Figure 14. It is evident that the shape of the impedance data from site corresponds closely to the data obtained from the passive steel specimen. This is indicated by both the x-axis range and the characteristic frequency.

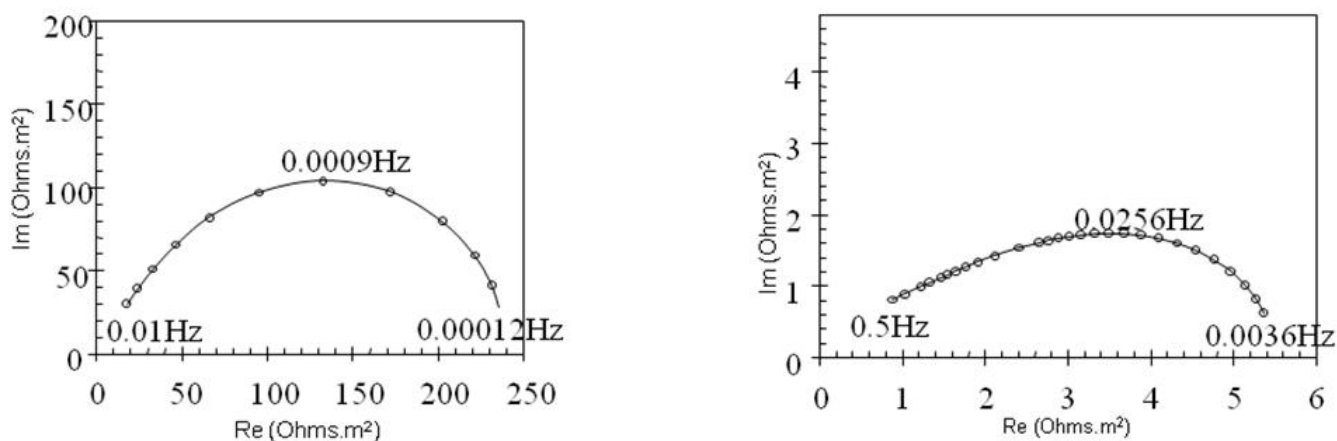

Figure 14: Published impedance data illustrating passive and corroding steel [19]

4 DISCUSSION

At the start of the study all the structures were evaluated for corrosion risk. Structures A2 and B1 were at most risk because the impressed current conductive coating anode had suffered significant deterioration. Chloride sampling results showed that these two structures had 40

% to 50 % of their test locations with chlorides greater than 1 % by weight of cement and 60 % to 66 % of their test locations with chlorides more than 0.4 % by weight of cement at the depth of steel. Thus, both of these beams had a substantial residual corrosion risk.

In the study presented here, the protective current has been interrupted for 24 months and the off steel potentials have shifted towards more positive values and have remained passive. Furthermore, the corrosion potential and corrosion rate data suggest that there is no significant corrosion activity on these structures. These results confirm the published hypothesis that long term-application of ICCP renders the steel passive and has a persistent protective effect in the absence of a negative potential shift. Of the two effects, chloride extraction and hydroxide production, the latter is considered to be the most important [20].

Most importantly, the cathodic protection treatment applied with a poorly performing anode system (as that shown on Figure 3) has been sufficient to induce and maintain steel passivity for a period of 24 months. These anodes were never capable of sustaining more than 20 mA/m² of current at the concrete surface, with steel surface area ranging between 1.4 to 2.2 times the concrete surface area. In several occasions the power supplies of the anode systems were voltage limited at current densities less than 2 mA/m² of concrete surface area. Whilst this is a low cathodic protection current density, it was capable of inducing a substantial protective effect as indicated by the negative steel potential shift (refer to Figure 10).

Moreover the condition of the impressed current conductive coating anode systems at the start of this project indicated that in some locations on these structures the current had been interrupted for a substantially longer period. Based on the results of this study it has been shown these anode systems have been capable of arresting ongoing corrosion and sustaining steel passivity despite providing low current densities. This is also supported by Polder et al. [21] who illustrated that only a small current will be sufficient to induce and sustain passivity.

Furthermore, it was observed that the zone layout of the ICCP systems was different, with older systems, such as those on structures A2 and B1, having a single zone for the whole of the structure whereas newer systems had multiple zones. However, no apparent difference was observed and the steel was rendered passive in all cases. Another observation was that newer installations of ICCP systems involved substantial concrete repairs which removed excessive chloride contamination (refer to Table 1).

The polarisation achieved by a short current pulse as shown for structure A3, indicates that long-term application of ICCP transforms the environment around the steel reinforcement. The steel has now been polarised to such a degree that only a brief current pulse (densities usually used for corrosion prevention) is required to achieve polarisation.

Repairs to old CP systems are clearly not critical for at least 24 months after the protection current has been interrupted. When considering refurbishment of existing ICCP systems which have deteriorated, the absence of corrosion signs and the polarisation of the reinforcement should be taken under consideration. The replacement system will need to be designed for cathodic prevention rather than cathodic protection as the steel has already been sufficiently polarised.

5 CONCLUSIONS

The site data presented here is consistent with laboratory data and results reported in previous works by others, indicating a persistent protective effect after the interruption of ICCP systems. More specifically we conclude the following:

- 1) After 24 months with no cathodic protection current, all the structures investigated have remained passive and with no corrosion signs. This includes structures where 60 % of the test locations had chloride contents exceeding 1 % by weight of cement at the depth of steel and would normally present a corrosion risk. This supports the published hypothesis that ICCP arrests ongoing corrosion and has persistent protective effect in the absence of a negative potential shift.
- 2) Low design current densities from low grade conductive coating anodes have been capable of inducing steel passivity in chloride contaminated structures. These anodes were never capable of sustaining more than 20 mA/m² of concrete surface, with steel surface area ranging between 1.4 to 2.2 times the concrete surface area. This suggests that design current densities can be kept to the lower spectrum of the suggested values of the design standards.
- 3) Dividing the ICCP system in smaller zones it did not appear to give any benefit with regards to protection or durability. At all cases of single and multi-zone systems, the reinforcement was found to be passive and the concrete repairs undertaken prior to the installation of the ICCP system would tend to remove excessive chloride contamination.
- 4) The absence of corrosion should be taken into account when repairing old CP systems. The replacement anode systems need only to deliver a low current density to achieve polarisation and prevent corrosion initiation.

ACKNOWLEDGEMENTS

The authors acknowledge the support and invaluable help throughout all the stages of this work of Chris Spence (Amey), Peter Gilbert (Amey), Dr. Vitalis Ngala (Mouchel) and Sam Beamish (Mouchel). They would also like to thank the Highways Agency, AECOM and the EPSRC (through the Centre for Innovative and Collaborative Engineering at Loughborough University) for their commercial and financial support.

6 REFERENCES

- [1] D. A. Koleva, Z. Guo, K. van Breugel, J. H. W. de Wit, Conventional and pulse cathodic protection of reinforced concrete: Electrochemical behaviour of the steel reinforcement after corrosion and protection, *Mater. Corros.* 60, (2009), 344-354.
- [2] BS EN 12696:2000, Cathodic Protection of Steel in Concrete, British Standards Institution, London, 2000.
- [3] M. Pourbaix, Atlas of Electrochemical Equilibrium in Aqueous Solutions, NACE International, Houston, TX, USA, 1996.
- [4] B. S Wyatt, Developments in Cathodic Protection of Steel in Concrete: Concrete Bridge Development Group, Annual Conference: Eurocodes and Innovation, Oxford 2009.
- [5] G. K. Glass, J. R. Chadwick, An investigation into the mechanisms of protection afforded by a cathodic current and the implications for advances in the field of cathodic protection, *Corros. Sci.* 36, (1994), 2193-2209.

- [6] J. P. Broomfield, J.S. Tinnea, Cathodic protection of reinforced concrete bridge components, final report. ID no: SHRPCUWP92618, 1992.
- [7] F.J. Presuel- Moreno, A. A. Sagiúés, S. C. Kranc, Steel activation in concrete following interruption of long-term cathodic polarisation, *Corrosion* 2002, Paper no. 02259.
- [8] G. K. Glass, B. Ready, L. Clark 2007, Making reinforced concrete immune from chloride corrosion, *Proc. Inst. Civ. Eng. Constr. Mater* 160, 155-164.
- [9] R. E. Stratful, The corrosion of steel in a reinforced concrete bridge, *Corrosion* 13, (1957), 43- 48.
- [10] B. Elsener, Half cell potential measurements – Potential mapping on reinforced concrete structures, RILEM TC 154-EMC: Electrochemical techniques for measuring metallic corrosion, *Mater. Struct.* 36, (2003), 461-471.
- [11] BA 35/90, Inspection and repair of concrete highway structures, British Standards Institution, London, 1990.
- [12] J.P. Broomfield, Corrosion of steel in concrete, understanding, investigation and repair, E & F. N. Spon, London, 1997.
- [13] M. Stern, A.L.L. Geary, Electrochemical polarisation I: A theoretical analysis of the shape of polarisation curves, *J. Electrochem. Soc.* 104, (1957), 56-63.
- [14] D. D. McDonald, M. C. H. McKubre, Electrochemical impedance techniques in corrosion science, *Electrochemical Corrosion Testing ASTM STP 727* – F. Mansfeld and U. Bertocci Eds., 1981, 110-149.
- [15] R. Polder, A. Tondi, R. Cigna, Concrete resistivity and corrosion rate of reinforcement, TNO report 93-BT-r0170, TNO Delft, 1993.
- [16] C. Andrade, C. Alonso, Test methods for on-site corrosion rate measurement of steel reinforcement in concrete by means of the polarisation resistance method, RILEM TC 154-EMC: Electrochemical techniques for measuring metallic corrosion, *Mater.Struct.* 37, (2004), 623-643.
- [17] Concrete Society, Technical Report 60, Electrochemical tests for reinforcement corrosion, Surrey, U.K. 2004.
- [18] C. Andrade, C. Alonso, On-site measurements of corrosion rate of reinforcements, *Constr. Build. Mater.* 15, (2001), 141-145.
- [19] G. K. Glass, A.M. Hassaein, N. R. Buenfeld, Obtaining Impedance Information on the Steel – Concrete Interface, *Corrosion* 54, (1997), 887-897.
- [20] G.K. Glass, A.C. Roberts, N. Davison, Hybrid corrosion protection of chloride-contaminated concrete, *Proc. Inst. Civ. Eng. Constr. Mater.* 161, (2008), 163-172.
- [21] R. Polder, W.H.A. Peelen, B.T.J. Stoop, E.A.C. Neef, Early stage beneficial effects of Cathodic Protection in Concrete Structures, Eurocorr 2009, Nice, France.

APPENDIX D PAPER 3

Full Reference

Christodoulou C, Goodier C, Austin S, Glass G and Webb J, On-site transient analysis for the corrosion assessment of reinforced concrete, *Corrosion Science*, 62 (2012), pp. 176 – 183
DOI information: 10.1016/j.corsci.2012.05.014

Abstract

A range of methods exist to assess the condition of steel reinforcement in concrete. The analysis of the transient response to a small perturbation has been employed successfully in laboratories to assess corrosion. This work examines a simplified method for the application of transient analysis to in-situ reinforced concrete structures. The complex analysis has been simplified and undertaken with the use of common spreadsheet packages. The results illustrate that transient response analysis is a viable technique for use on site and appears to provide a more accurate representation of steel corrosion current densities at very low values than polarisation resistance.

Keywords – Concrete, steel reinforced concrete, electrochemical impedance spectroscopy, polarization, cathodic protection

Paper type – Journal

1 INTRODUCTION

The study outlines a trial of transient response analysis on full-scale motorway bridge structures to obtain information concerning the steel-concrete interface and is part of a larger study to assess the long-term sustained benefits offered by Impressed Current Cathodic Protection (ICCP) after the interruption of the protective current [1]. These structures had previously been protected for 5 to 16 years by an ICCP system prior to the start of the study. The protective current was interrupted, in order to assess the long-term benefits provided by ICCP after it has been turned off. This paper develops and examines a simplified approach for the on-site use of transient response analysis and discusses the potential advantages of the technique as a tool for the assessment of the corrosion condition of steel in reinforced concrete structures.

2 THEORETICAL BACKGROUND

Impedance has been used previously to obtain corrosion information regarding the steel-concrete interface [2-3]. To obtain this information, data is required at very low frequencies (mHz – μ Hz) [2-5]. The conventional method of obtaining impedance is to subject the specimen to a cyclic perturbation at the frequency of interest and analyse the response [2, 6]. However, at very low frequencies it is preferable to subject the specimen to a perturbation and analyse its response resulting from the perturbation [7-10].

The steel-concrete system can be described in the form of an electrical circuit. A common and simple approach is the use of the Randle's circuit (Figure 1a). This analysis characterises the steel-concrete interface with a polarisation resistance (R_p), interfacial capacitance (C) and electrolyte resistance (R_e). R_p can be directly associated with the steel corrosion current density (I_{corr}) [11-12]. The validity of the simple Randle's circuit to adequately represent the steel-concrete interface is still subject to debate. Impedance data may appear to produce a distorted or flattened semi-circle and at high frequencies a second semi-circle may appear [7].

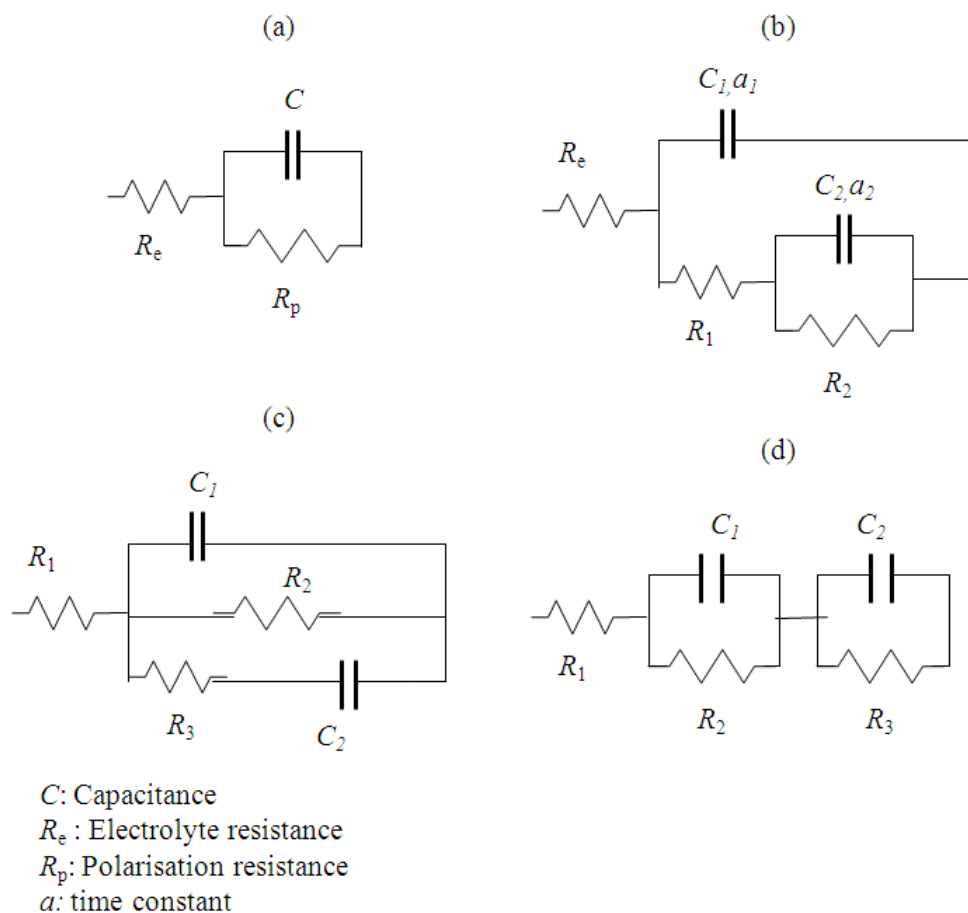

Figure 1: Various electrical circuits to simulate the steel concrete interface, (a) Randle's circuit, (b) modified Randle's circuit holding two time constants [14], (c) model proposed by Feliu et al. [15], (d) model proposed by John et al. [16].

A number of alternative electrical circuits have also been proposed incorporating additional components in order to obtain a better fitting of the experimental data, as shown in Figure 1b, 1c and 1d [13-16]. These additional components improve the fit of the data because each component represents an additional variable that may be adjusted to improve the fit.

Impedance data may be presented in a Bode plot of the response function of a linear-time invariant system versus frequency or a Nyquist plot as a parametric plot of a transfer function, with the latter most commonly used [17]. The shape of the impedance plane on a Nyquist plot gives an indication regarding the accuracy of the model. A near perfect semi-circle will indicate that the impedance response corresponds to a single activation-controlled process (Figure 1a), a depressed semi-circle will indicate a need for parallel components (Figures 1b and 1c) model and multiple semi-circles in general indicates a series of components (Figure 1d) [17].

In this work the simplified Randle's circuit has been applied due to its simplicity for data analysis [7, 15]. This approach provides an estimate of the corrosion condition in critical sections of the structure and is particularly suitable for use on full-scale site structures due to its simplicity. Feliu et al. [18] also support the use of a simplified abstract representation of

the system in order to interpret its fundamental properties as opposed to a more accurate but significantly more complex circuit model.

Transient response analysis is used to overcome the complexity of the frequency response analysis and simplified for use on site. Transient analysis is the analysis of the response of an electrode after the application of a short pulse over a period of time.

3 TRANSIENT DATA ANALYSIS

Laplace transformation is used to convert data on the time domain to data on the frequency domain. This transformation may be expressed as [19]:

$$\bar{Z} = \frac{\bar{V}}{\bar{I}} \quad (\text{Eq. 1})$$

The Laplace transformations of \bar{V} and \bar{I} can be written as [3]:

$$\bar{V} = a + jb = \int_0^{\infty} \Delta E(t) \cos(\omega t) dt - j \int_0^{\infty} \Delta E(t) \sin(\omega t) dt \quad (\text{Eq. 2})$$

$$\bar{I} = a + jb = \int_0^{\infty} I(t) \cos(\omega t) dt - j \int_0^{\infty} I(t) \sin(\omega t) dt \quad (\text{Eq. 3})$$

where ΔE is the difference in potential, I is the current, t is the time and ω is the range of angular frequencies of interest.

When the highest frequency of interest has a period which is much greater than the period of the pulse $\left(\frac{1}{\omega} \gg T\right)$ and for times less than the period of pulse ($I(t) \neq 0$) then $\sin(\omega t) \cong 0$, $\cos(\omega t) \cong 1$ and Equation (3) becomes:

$$\bar{I} = \int_0^{\infty} I(t) dt = Q \quad (\text{Eq. 4})$$

where ω' is the highest frequency of interest, T is the period of the pulse and Q is the charge.

Under these conditions the Laplace transformation of the current perturbation will be the charge.

Equations 1 and 2 can be solved using standard spreadsheet packages and is illustrated as follows:

- i. ΔE and I are measured from the transient data obtained on site. A typical representation is given by Figure 2a. The data is a set of discrete points.
- ii. The voltage transformation from Equation (2) is a function of the angular frequency (ω), in the range of frequencies of interest. Figure 2b illustrates a typical example of the contents of the real integral of Equation (2) at a selected value of $\omega = 0.04\text{Hz}$.
- iii. Figure 2c illustrates a typical example of the contents of the imaginary integral of Equation (2) at a selected value of $\omega = 0.04\text{Hz}$.
- iv. The real and imaginary integrals can be calculated simply by the respective areas under the curves in Figures 2b and 2c. For equally spaced points, it is calculated as the sum of the points multiplied by the spacing (seconds) between the points.

- v. The real and imaginary parts of equation (2) can then be divided individually by the charge to obtain the impedance for this particular angular frequency.
- vi. This gives a point on the Nyquist plot at a selected value $\omega = 0.04\text{Hz}$. The real integral divided by the charge provides the x-axis value and the imaginary integral divided by the charge provides the y-axis value (Figure 2d).
- vii. The above procedure can be repeated at different angular frequencies (ω_x) in order to obtain the impedance spectrum. The procedure provides a suitably simplified analysis process for use with site data.

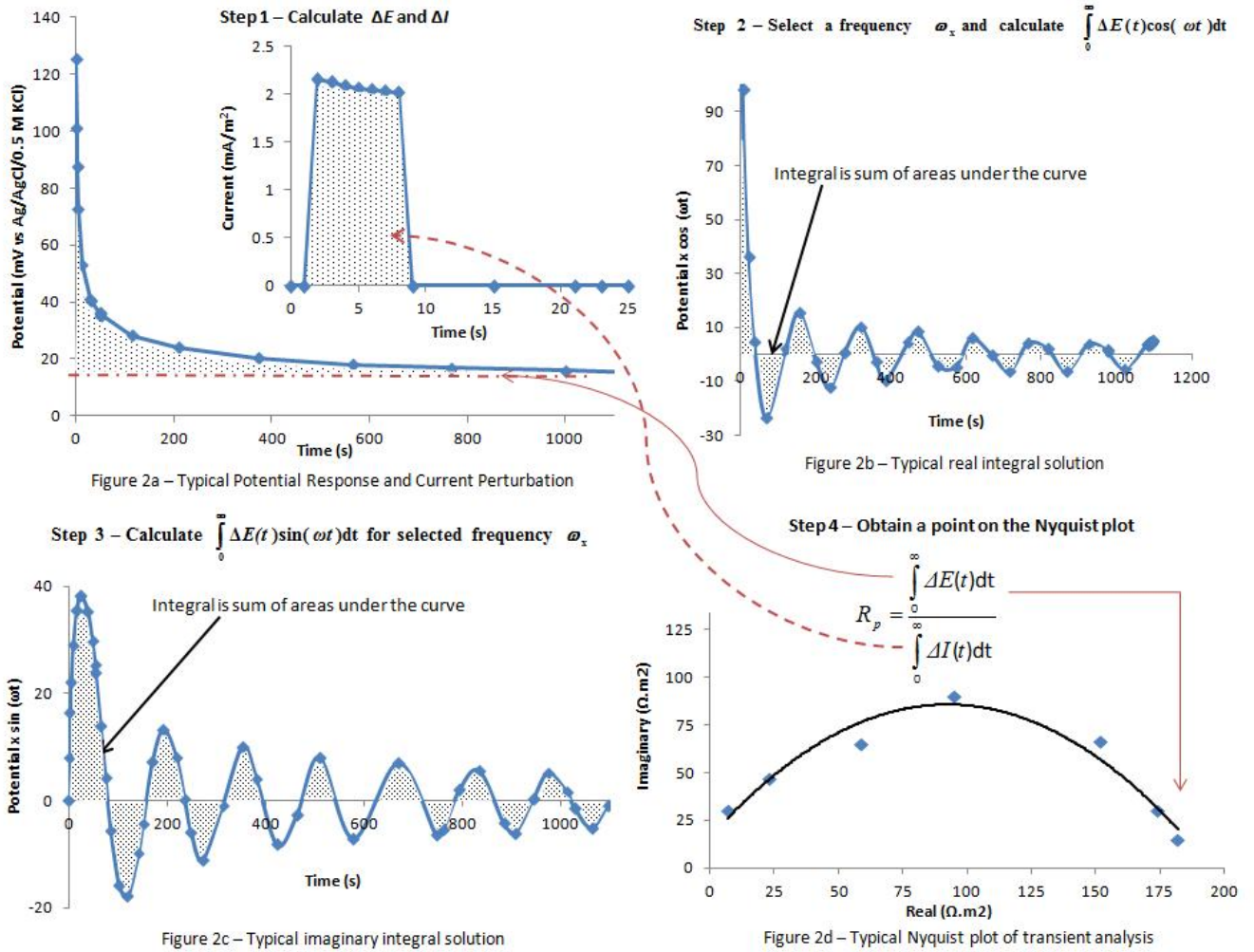

Figure 2: Graphical representation of the calculations involved in converting transient data into impedance ($\omega > 0$) and resistance ($\omega = 0$).

For very low frequencies where $\omega \cong 0$ equation (2) may be simplified further as follows:

$$\bar{V} = \int_0^{\infty} \Delta E(t) dt \quad (\text{Eq. 5})$$

Therefore equation (1) becomes:

$$\bar{Z} = \frac{\int_0^{\infty} \Delta E(t) dt}{\int_0^{\infty} I(t) dt} = R_p \quad (\text{Eq. 6})$$

The impedance value of equation (6) is given by the area under the curve of Figure 2a for the potential transient divided by the charge (DC resistance). The low-frequency real axis intercept (highest x-axis value of the semi-circle) represents the polarisation resistance (R_p) and electrolyte resistance (R_e). The high-frequency real axis intercept (lowest x-axis value of the semi-circle) represents the electrolyte resistance (R_e). Applying a short pulse and measuring the potential decay after the pulse has been applied eliminates the effect of R_e in the measurement process.

The observed peak in the Nyquist plot is the characteristic frequency of the structure from which useful information about the corrosion state of the reinforcement can be obtained. The characteristic frequency of the steel-concrete interface (f_c) can be obtained from the following Equation [3]:

$$f_c = \frac{1}{2\pi R_p C} \quad (\text{Eq. 7})$$

The highest frequency is limited by the period of the pulse. The lowest frequency is not limited if we can assume that after the potential has decayed to the rest potential there is no contribution from the remaining area under the transient.

Care must be taken however, as for some models the above assumptions will not be true. In these exceptions, transients should be measured for a period which is longer than the period which is longer than the lowest period of the frequency of interest.

Having obtained impedance information for the steel-concrete interface, it is also possible to calculate the corrosion current density of the section as it is inversely proportional to the polarisation resistance [5, 11].

$$I_{\text{corr}} = \frac{B}{R_p} \quad (\text{Eq. 8})$$

where B is a constant of the metal/electrolyte system depending on the Tafels constants of the polarisation curves. For steel in concrete and in particular site uses, a value of 26mV is typically usually used for simplicity [5, 7, 11, 20].

4 EXPERIMENTAL PROCEDURE

A number of steel-reinforced concrete structures were selected to identify the long-term benefits afforded by ICCP. All the structures had their protective current interrupted for a period of 36 months (since October 2007) in order to evaluate these long-term benefits [1]. A total of 10 structures were selected based on the age of the installed ICCP system, accessibility and chloride levels. All structures selected for this study were protected by ICCP and the anode system comprised a conductive anode coating. The anode systems were from

varying anode suppliers and this helped to also assess their relative performance and durability.

Samples for chloride analysis were collected to identify areas of residual risk. The locations of testing were in original un-repaired concrete and the chloride contents are expressed as weight percent of cement and for a depth of 25 to 50 mm where the reinforcement is present (Table 1). From the results it can be observed that there were several locations within the structures where the chloride content at the depth of the reinforcement was sufficiently high to pose a corrosion risk following interruption of the protective current.

Based on the chloride sampling at the depth of reinforcement, 2 locations representative of high corrosion risk for each structure were selected for further monitoring. These locations, of an approximate area of 0.35 m², were cleaned and had the old conductive coating anode removed. Following cleaning, a new conductive coating anode (coloured black) was installed as shown in Figure 3. One Ag/AgCl/0.5 M KCl reference electrode was installed in the middle of each anode segment to assess the steel potential shift.

Structure Reference	Year of Installation	Age of structure at testing (years)	Locations with Cl- greater than 1% by weight of cement (at depth of steel)	No of test locations	Locations with Cl- greater than 0.4% by weight of cement (at depth of steel)
A1	1991	40	2	4	4
A2	1995	40	2	5	3
A3	1995	40	2	5	5
B1	1996	40	3	6	4
B2	1998	40	1	5	4
B3	1998	40	2	5	3
B4	1998	40	2	5	3
C1	1999	40	0	5	2
C2	2002	40	0	5	1
C3	2000	40	0	5	1

Table 2: Details of the 10 structures investigated by Christodoulou et al. 2010 [1].

The existing anode segment acts as a counter electrode and the rest of the anode system acts as a guard ring (Figure 3) to confine a current perturbation of the anode segment to the steel below the anode segment during the corrosion rate measurement process [1].

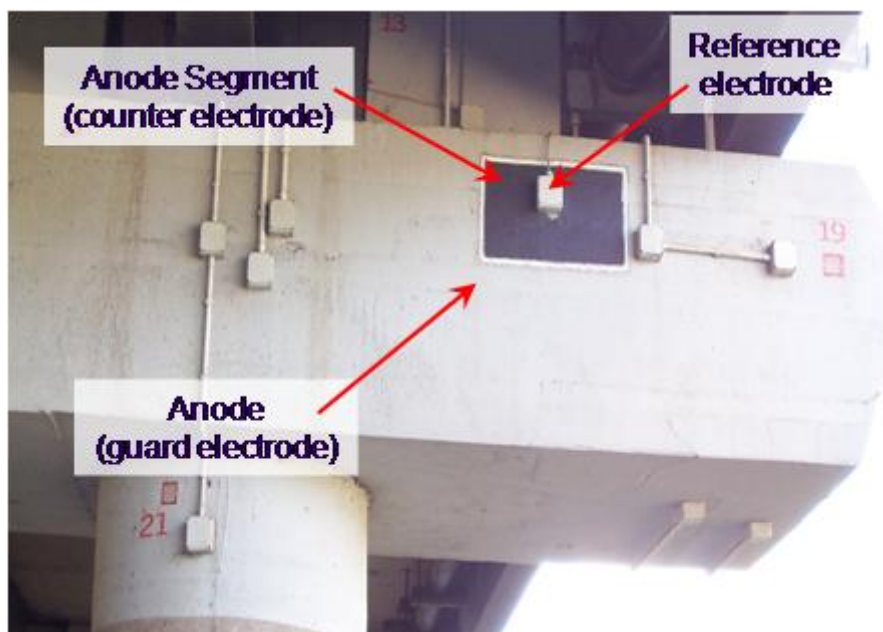

Figure 3: Guard ring arrangement on a reinforced concrete motorway cross beam

The technique limits the edge effects of a current perturbation applied from a counter electrode to the concrete structure by also applying current from a guard electrode surrounding the counter electrode. The guard ring method for confinement of the current in a localised area is a popular and successful technique used in laboratory and site applications [7, 21-24]. The method allows corrosion monitoring of selected localised areas of a large reinforced concrete structure. Minimising edge effects is particularly important when the steel reinforcement is passive.

The full testing arrangement developed is illustrated in Figure 4. Briefly the main elements were the existing power supply enclosure located at ground-level, the existing ICCP enclosure at high-level, the monitored anode segment and a new enclosure at high-level to facilitate the new connections to the system [1]. The current density delivered by the guard electrode was adjusted to be the same as that delivered by the counter electrode.

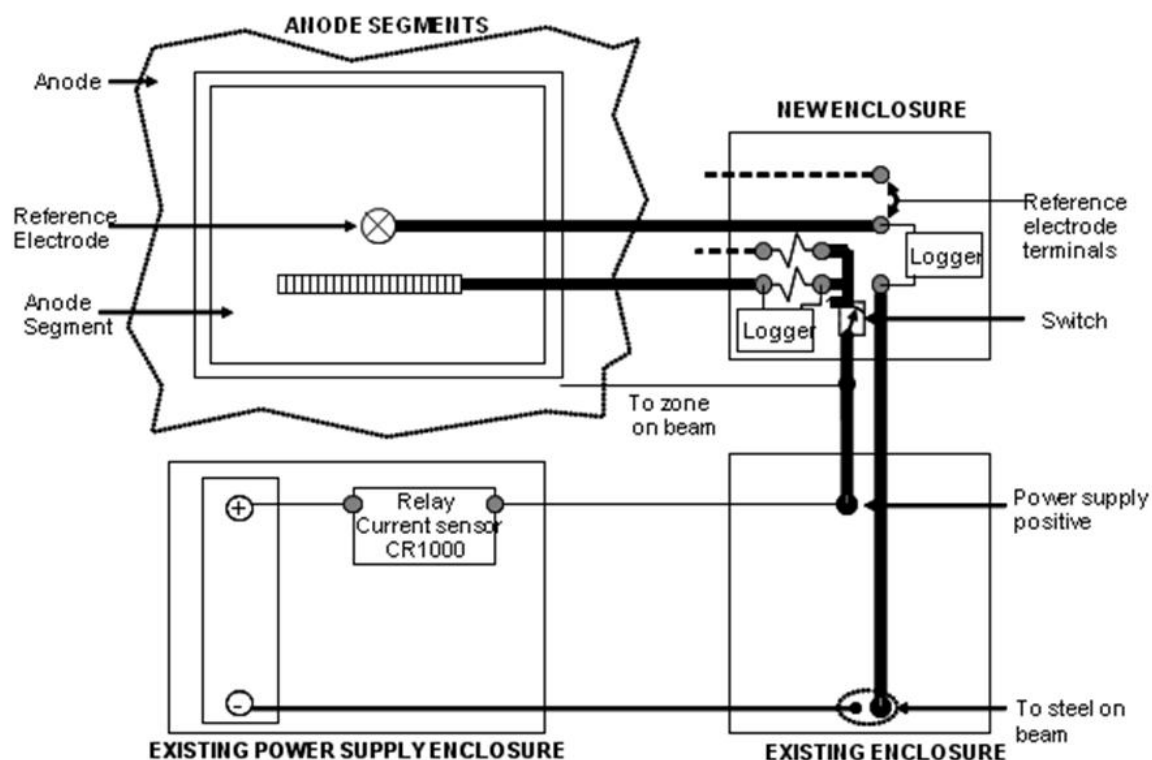

Figure 4: Testing arrangement [1]

At each site visit two tests were undertaken on each structure. During the first test, the system received a short charge of approximately 5 seconds, and the potential decay was recorded at 1 second intervals with use of a data logger for a period up to 15 minutes.

The second test involved applying a perturbation to the structure for a longer period of approximately 10 minutes. The data logger was used again to record the polarisation of the structure. The data collected was then used to undertake polarisation resistance analysis.

5 ANALYSIS

A pattern arose from the potential decay data recorded during the transient response testing: the structures exhibited a relative long potential decay back to their pre-pulse rest potential. This is consistent with data reported by others for passive reinforcement [3, 25-27]. Figure 2a illustrates typical potential decay data. This provides a basis for a criterion for use on site to quickly determine the corrosion state of reinforcement. Steel potentials were measured against a Ag/AgCl/0.5 M KCl reference electrode.

From the analysis of the potential transients a set of data was obtained for each structure in the present study over a period of 31 months. Figure 5 illustrates typical Nyquist plots arising from the analysis of transients obtained from one site visit for all structures. The results illustrate high polarisation resistance (R_p) values in the range of 51 to 210 $\Omega \cdot m^2$ and very low characteristic frequencies (f) in the region 1 to 5 mHz. It can be observed that the associated I_{CORR} are very low indicating passive reinforcement. By comparison, linear polarisation resistance analysis calculated the corrosion current density to be 0.03 mA/m² whereas a corrosion current density of 0.15 mA/m² was obtained from the transient response analysis.

The data obtained in other studies [28-29] also supports that non-corroding reinforcement will have very low characteristic frequencies and high polarisation resistance values.

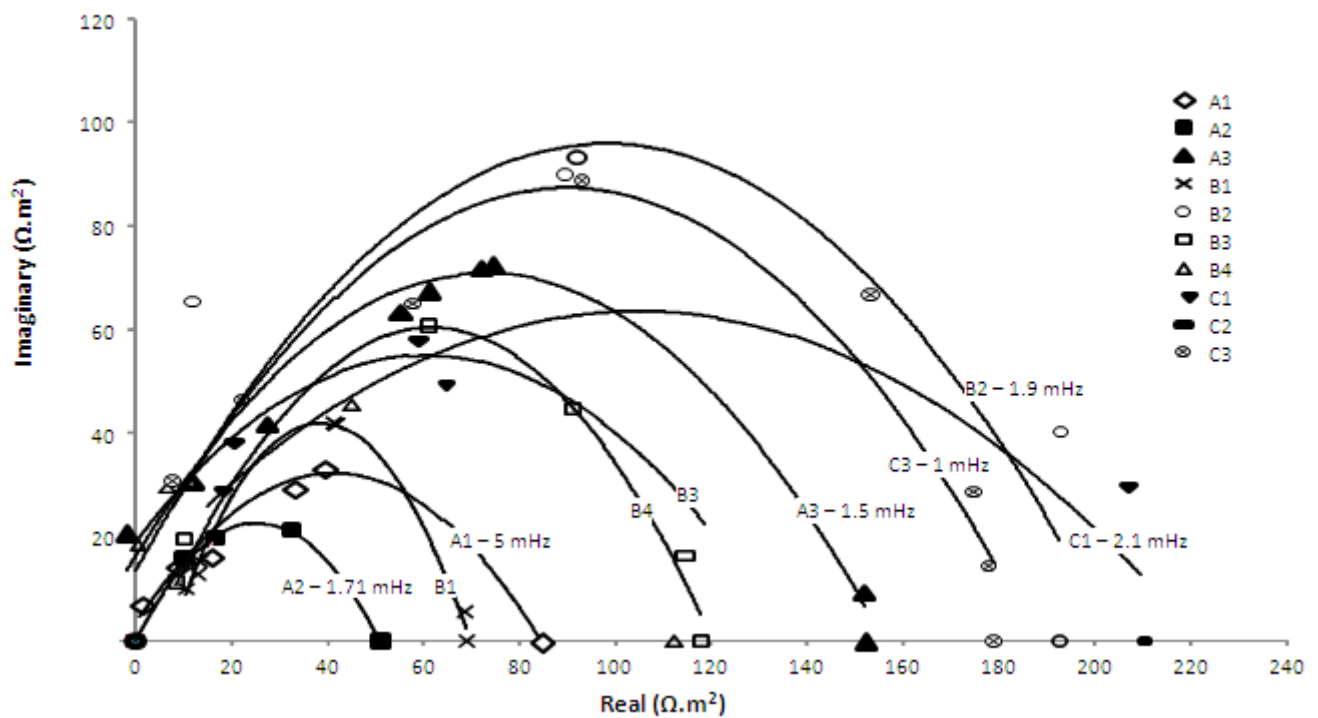

Figure 5: Nyquist plots arising from transient analysis for all ten structures

Figure 6 plots the associated corrosion current densities based on transient response analysis of all 10 structures as a function of time over a period of 30 months. It can be observed that all the structures retained their passive condition despite several locations having a high residual chloride content. At the same time corrosion current densities were also monitored based on the polarisation resistance testing as part of the previous work [1]. Figure 7 illustrates the results of polarisation resistance testing over a period of 36 months. Both the polarisation resistance and transient analysis data suggest that the steel remains passive.

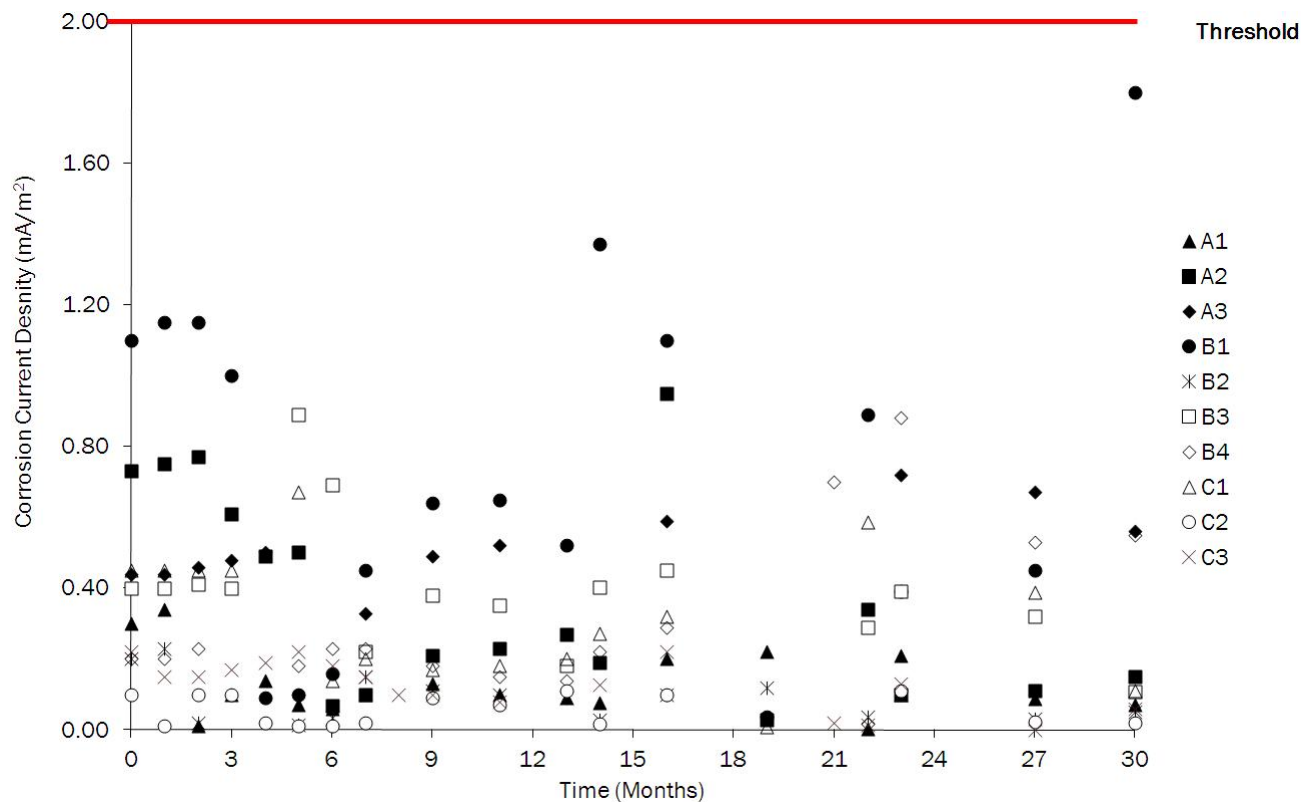

Figure 6: Corrosion current densities from transient response analysis over a period of 30 months

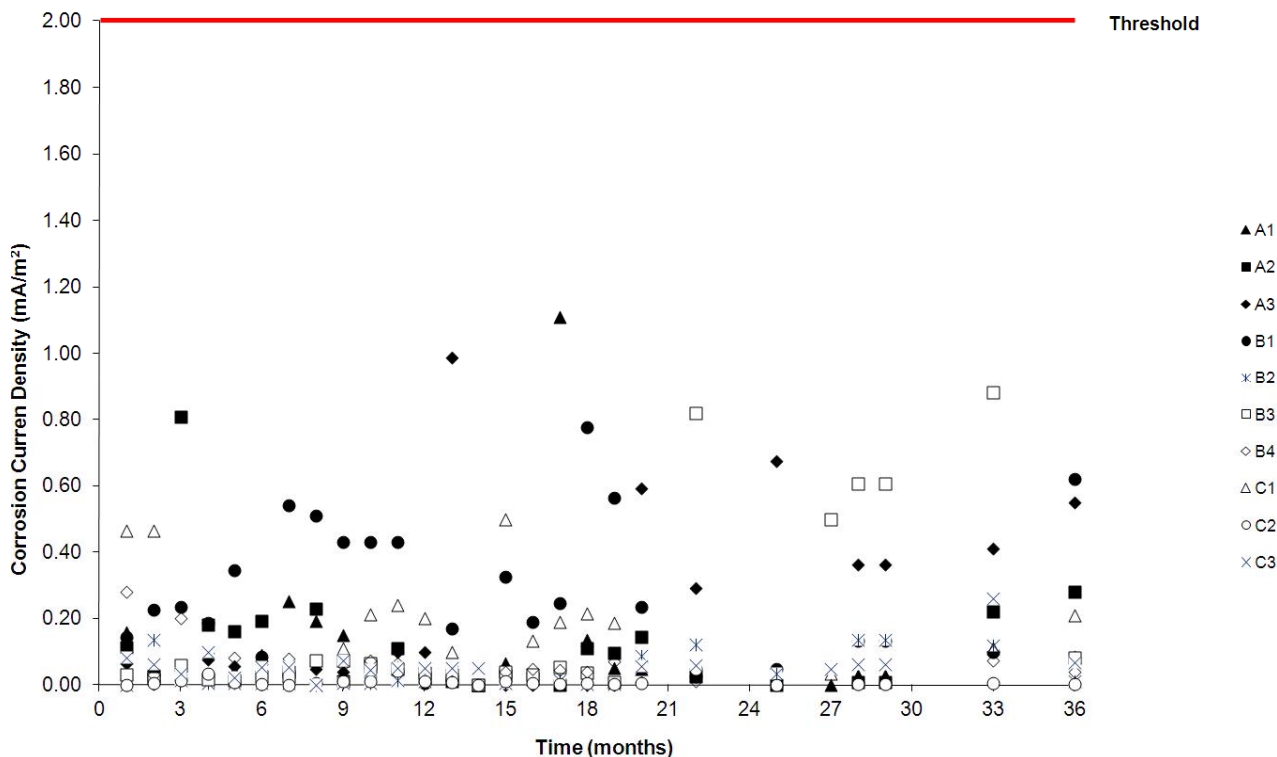

Figure 7: Corrosion current densities from polarisation resistance testing over a period of 36 months [1]

Looking at the corrosion current densities obtained for structure A3 (Figure 8), it can be observed that transient analysis provided more consistent data than polarisation resistance with regards to the corrosion status of the monitoring locations on the structure. Occasionally, polarisation resistance returned unrealistically low corrosion current densities, something that was observed on other structures too.

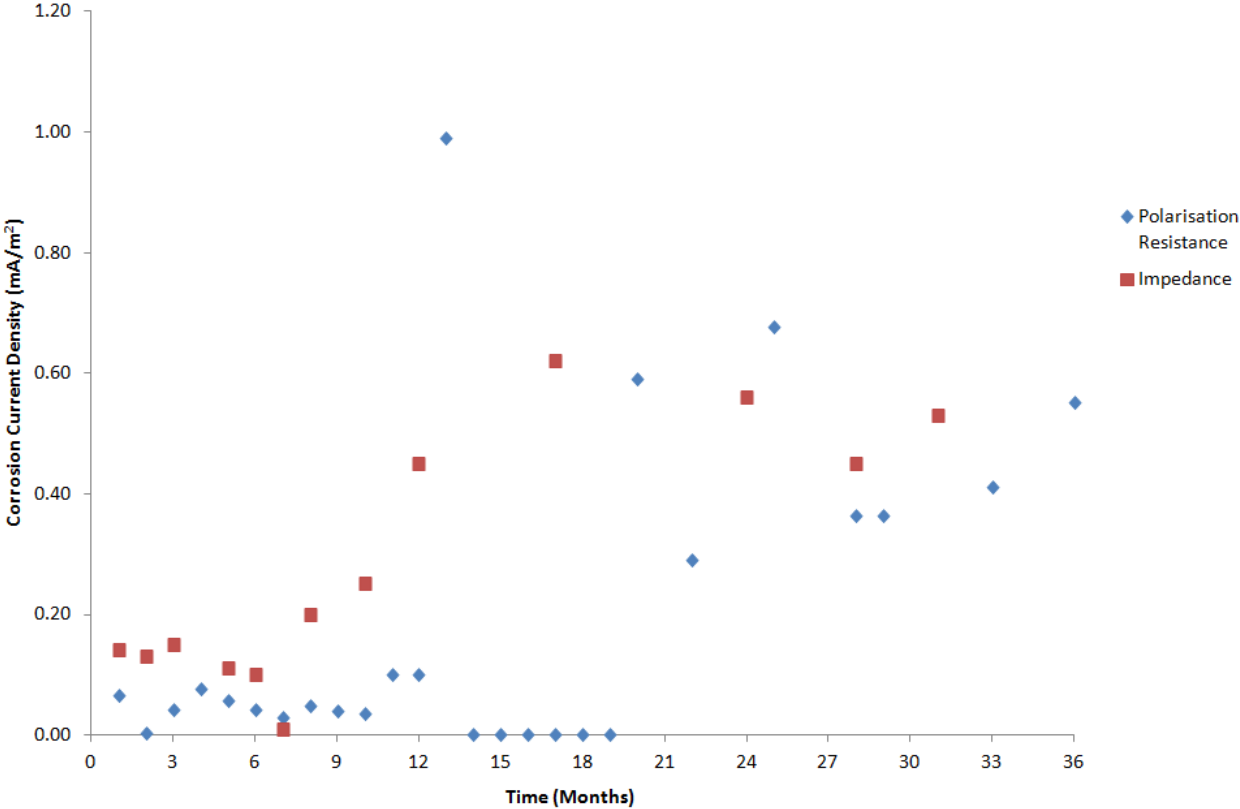

Figure 8: Corrosion current densities for structure A3 obtained from polarisation resistance testing against transient analysis

Figure 9 compares the results obtained from polarisation resistance and transient response analysis in a histogram. It can be observed that polarisation resistance consistently produced very low corrosion current densities. It is noted that these data are provided with no check on whether the corrosion current densities measured, actually do represent the corrosion rates. This is a set of measurements taken from full scale bridge structures and an assumption is made that the information drawn from the method gives indeed the true corrosion rate.

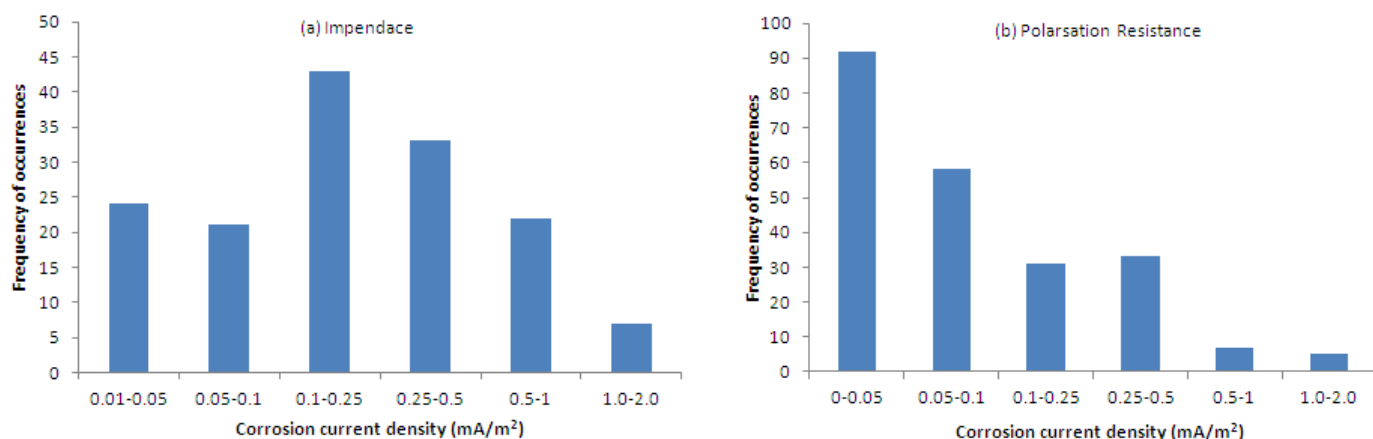

Figure 9: Return of results from transient response and polarisation resistance analysis. (*Note: Frequency is dimensionless and the x-axis does not cover equal-interval or numerically consistent divisions of the x axis. The graph should not be read as a quantitative distribution or histogram.*)

Table 2 then illustrates typical corrosion current densities for all 10 structures and their calculated interfacial capacitance. It can be seen that corrosion current densities for non-corroding structures are in general associated with high polarisation resistance, low interfacial capacitance and very low characteristic frequencies. Similar findings have been reported by others [3, 29].

Structure Reference	Locations with Cl ⁻ greater than 1% by weight of cement	Characteristic Frequency (f) Hz	Polarisation Resistance (R_p) $\Omega.m^2$	Corrosion Current Density (I_{corr}) mA/m ²	Capacitance (C) F/m ²
A1	2	0.005053	84	0.31	0.37
A2	2	0.00171	51	1.12	1.42
A3	2	0.0015	152	0.13	0.70
B1	3	0.0019	69	1.26	1.21
B2	1	0.0066	192	0.27	0.13
B3	2	0.000783	431	0.07	0.47
B4	2	0.003	112	0.23	0.47
C1	0	0.00215	209	0.12	0.35
C2	0	0.0018	477	0.05	0.19
C3	0	0.001052	179	0.15	0.85

Table 2: Calculated capacitance and corrosion current densities based on impedance analysis

6 DISCUSSION

Impedance information arising from potential transients can produce useful information concerning the corrosion state of steel reinforcement. The results obtained during this study confirm the previously reported findings [1] that there is a low corrosion risk from all structures examined despite 36 months of no protection. Furthermore, the impedance spectra obtained on-site from full-scale reinforced concrete structures are similar to published data

obtained on passive specimens in laboratory testing confirming the passive status of the steel reinforcement [3, 26, 30]. The complex analysis required for impedance has been simplified and successfully applied to full-scale site structures and undertaken with common spreadsheet packages.

The data collected from transient response analysis indicated that all structures had a relatively long potential decay of approximately 10 minutes back to their rest potential after the application of a short perturbation. Passive steel reinforcement can be associated with a relative long potential decay (>10 mins) back to its rest potential after the application of a short (<5 s) current pulse. It is postulated that this could be developed into a rapid technique for assessing the corrosion condition of reinforced concrete structures on site and idea also supported by others [27].

Polarisation resistance in general returned more frequently extremely low I_{corr} values as opposed to transient response analysis. This indicates the possibility that polarisation resistance may under-estimate the corrosion current densities or transient response analysis may over-estimate them. The differences observed may be explained by the size of the data set, polarisation resistance effects and the length of perturbation.

Transient response analysis is based on a large amount of data collected over a specific time period, typically in excess of 300 points, whereas with polarisation resistance the data collected is focused at two points only, i.e. the start and the end of the testing. The larger data set helps reduce scatter, which may be a problem for site data.

Polarisation resistance measurements are obtained while current is applied, whereas for transient response analysis all the data are collected after the current perturbation has been applied and as such they do not include the effects of the resistance of the concrete (R_c). Therefore, corrosion current densities through polarisation resistance analysis have to be compensated for IR effects. Furthermore, the perturbation applied during polarisation resistance is over a greater time and of higher average magnitude than the perturbation for the transient response analysis, which also might affect the results.

Capacitance of the steel concrete interface was not directly measured as part of this work but it was calculated based on the characteristic frequency and the polarisation resistance of the structure. The calculated interfacial capacitance was found to be significantly lower than that reported for active steel in other studies [3, 29, 31]. It is postulated that the presence of an intact passive oxide film contributes to this effect.

7 CONCLUSIONS

- 1) The analysis of transients to obtain information on the corrosion condition of steel in concrete has been successfully applied to full-scale site structures for the first time. The complex analysis required for impedance can be simplified and can be undertaken with the use of common spreadsheet packages. Polarisation resistance which is related to the corrosion current density is equal to the area under a potential time transient divided by an area under a current pulse perturbation which was applied to produce the potential transient.
- 2) Passive steel reinforcement is associated with a relative long potential decay (>10 mins) back to its rest potential after the application of a short (<5 s) current pulse. It is

postulated that this could be developed in the future into a rapid technique for assessing the corrosion condition of reinforced concrete structures on site.

- 3) At low corrosion current densities (up to 2 mA/m^2) transient response analysis appears to provide more accurate data than that obtained from the polarisation resistance analysis. Possible reasons for this include the analysis of a larger data set to obtain the transient response, the use of a smaller perturbation and the removal of the concrete resistance.
- 4) The interfacial capacitance (C) calculated from the characteristic frequency of the structures appears to be lower than that published for corroding structures. It is postulated that the presence of an intact passive oxide film contributes to this effect.

ACKNOWLEDGEMENTS

The authors would like to thank the Highways Agency, AECOM and the EPSRC (through the Centre for Innovative and Collaborative Engineering at Loughborough University) for their commercial and financial support.

8 REFERENCES

- [1] C. Christodoulou, G.K. Glass, J. Webb, S. Austin, C. Goodier, Assessing the long term benefits of Impressed Current Cathodic Protection, *Corros. Sci.* 52 (2010) 2671.
- [2] D.D. McDonald, M.C.H. McKubre, Electrochemical impedance techniques in corrosion science, in: F. Mansfeld, U. Bertocci (Eds.), *Electrochemical Corrosion Testing ASTM STP 727*, 1981, pp. 110–149.
- [3] G.K. Glass, A.M. Hassanein, N.R. Buenfeld N.R, Obtaining impedance information on the steel-concrete interface, *Corrosion* 54 (1998) 887 – 897.
- [4] V. Feliu, J.A. Gonzalez, C. Andrade, S. Feliu, Equivalent circuit for modelling the steel concrete interface. II. Complications in applying the Stern-Geary equation to corrosion rate determinations, *Corros. Sci.* 40 (1998) 995 – 1006
- [5] V. Feliu, J.A. Gonzalez, S. Feliu, Corrosion estimates from the transient response to a potential step, *Corros. Sci.* 49 (2007) 3241 – 3255.
- [6] D.D. McDonald, E. Sikora, G. Engelhardt, Characterizing electrochemical systems in the frequency domain, *Electrochim. Acta*, 43 (1998) 87 – 107.
- [7] C. Andrade, C. Alonso, Corrosion rate monitoring in the laboratory and on-site, *Constr. Build. Mater.* 10 (1996) 315 – 328.
- [8] G.K. Glass, A.M. Hassanein, N.R. Buenfeld, Low frequency impedance data by Laplace transformation of coulometrically induced transients, *Electrochim. Acta* 43 (1998) 1863 – 1871.
- [9] G.K. Glass, An assessment of the coulometric method applied to the corrosion of steel in concrete, *Corros. Sci.* 37 (1995) 597 – 605.
- [10] D. D. Macdonald, Y. A. El-Tantawy, R. C. Rocha-Filho and M. Urquidi-Macdonald, Evaluation of Electrochemical Techniques for Detecting Corrosion of Rebar in Reinforced Concrete. Report No. SHRP-ID/UFR-91-524. Vol. 1. Strategic Highway Research Program, Washington (1991).
- [11] C. Andrade, C. Alonso C. 2004, Test methods for on-site corrosion rate measurement of steel reinforcement in concrete by means of the polarisation resistance method, RILEM TC

- 154-EMC: Electrochemical techniques for measuring metallic corrosion, *Materials and Structures* 37 (2004) 623 – 643.
- [12] M. Stern, A.L. Geary, Electrochemical polarisation I: A theoretical analysis of the shape of polarisation curves, *J. Electrochem. Sci.* 104 (1957) 55 – 63.
- [13] V. Feliú, J.A. Gonzalez, C. Andrade, S. Feliú, Equivalent circuit for modelling the steel-concrete interface. I. Experimental evidence and theoretical predictions, *Corros. Sci.* 40 (1998) 975 – 993
- [14] I. Martinez, C. Andrade, Application of EIS to cathodically protected steel: Test in sodium chloride solution and in chloride contaminated concrete, *Corros. Sci.* 50 (2008) 2948 – 2958.
- [15] S. Feliú, J.A. Gonzalez, C. Andrade, V. Feliú, The determination of the corrosion rate of steel in concrete by a non-stationary method, *Corros. Sci.* 26 (1986) 961 – 970.
- [16] G. John, P. Searson, J. Dawson, *Brit. Corros. J.* 16 (1981) 102-106.
- [17] M.E. Orazem, B. Tribollet, *Electrochemical Impedance Spectroscopy*, The Electrochemical Society Series, John Wiley & Sons, New Jersey, 2008.
- [18] S. Feliu, J.C. Galvan, S. Feliu Jr., J. Simancas, J.M. Bastidas, M. Morcillo, E. Almeida, Differences between apparent polarization resistance values obtained in the time and frequency domains, *J. Electrochem. Chem.* 381 (1995) 1 – 4.
- [19] M.I. Jafar, J.L. Dawson, D.G. John, “Electrochemical Impedance and Harmonic Analysis Measurements on Steel in Concrete” in *Electrochemical Impedance: Analysis and Interpretation*, eds. J.R. Scully, D.C. Silverman, M.W. Kendig, ASTM STP 1188 (Philadelphia, PA: ASTM, 1993), p. 384.
- [20] J.A. Gonzalez, J.M. Miranda, S. Feliu, Considerations on reproducibility of potential and corrosion rate measurements in reinforced concrete, *Corros. Sci.* 46 (2004) 2467 – 2485.
- [21] C. Andrade, C. Alonso, On-site measurements of corrosion rate of reinforcements, *Constr. Build. Mater.* 15 (2001) 141 – 145.
- [22] S. Feliu, J.A. Gonzalez, J.M. Miranda, V. Feliu, Possibilities and problems for in situ techniques for measuring steel corrosion rates in large reinforced concrete structures, *Corros. Sci.* 47 (2005) 217 – 238.
- [23] Concrete Society, Technical Report 60, *Electrochemical Tests for Reinforcement Corrosion*, Surrey, UK, 2004.
- [24] J.P. Broomfield, J. Rodriguez, L.M. Ortega, A.M. Garcia, Field measurement of the corrosion rate of steel in concrete using a microprocessor controlled unit with a monitored guard ring for signal confinement, *Techniques to assess the corrosion activity of steel reinforced concrete* (Berke, N. S. *et al.* Eds.), ASTM STP 1276, American Society for Testing and Materials, Pennsylvania, 1995.
- [25] J.A. Gonzalez, A. Cobo, M.N. Gonzalez, S. Feliu, On-site determination of corrosion rate in reinforced concrete structures by use of galvanostatic pulses, *Corros. Sci.* 43 (2001) 611 – 625.
- [26] N. Birbilis, K.M. Nairn, M. Forsyth, On the electrochemical response and interfacial properties of steel-Ca(OH)₂ and the steel-concrete system measured using galvanostatic pulses, *Electrochim. Acta* 49 (2004) 4331 – 4339.
- [27] N. Birbilis, K.M. Nairn, M. Forsyth, Transient response analysis of steel in concrete, *Corros. Sci.* 45 (2003) 1895 – 1902.
- [28] D.W. Law, S.G. Milard, J.H. Bungey, Galvanostatic pulse measurements of passive and active reinforcing steel in concrete, *Corrosion* 56 (2000) 48 – 56.
- [29] G.K. Glass, C.L. Page, N.R. Short, J.Z. Zhang, The analysis of potentiostatic transients applied to the corrosion of steel in concrete, *Corros. Sci.* 39 (1997) 1657 – 1663.

[30] A. A. Sagues, S. C. Kranc and E. I. Moreno, The time-domain response of a corroding system with constant phase angle interfacial component: Application to steel in concrete, *Corros. Sci.* 37 (1995) 1097 - 1113.

[31] K. Videm, R. Mydral, Electrochemical behaviour of steel in concrete and evaluation of the corrosion rate, *Corrosion* 53 (1997) 734 – 742.

[This page is left intentionally blank]

APPENDIX E PAPER 4

Full Reference

Christodoulou C, Goodier C, Austin S, Webb J, Glass G, A new arrangement of galvanic anodes for the repair of reinforced concrete structures, *Construction and Building Materials*, 50 (2014), pp. 300 – 307, DOI information: 10.1016/j.conbuildmat.2013.09.062

Abstract

Discrete galvanic anodes are traditionally embedded in the patch repairs of steel reinforced concrete (RC) structures to offer corrosion prevention. This research investigated the performance of galvanic anodes installed in the parent concrete surrounding the patch repair, in order to explore the performance of such a new arrangement and identify its potential for wide-scale application.

This arrangement was tested on a RC multi-story car park and a RC bridge, with both suffering from chloride-induced corrosion of the reinforcement. The performance of the anodes was assessed using close-interval potential mapping for 215 days after installation. The results indicate that the anodes polarised the steel at a significant distance away from the patch repair interface, up to 600 mm in some cases. It illustrates that such an arrangement may be advantageous when repairing RC structures as the corrosion prevention can be targeted at the steel in the surrounding parent concrete, which is traditionally considered to be at higher risk due to incipient anode development.

Keywords – Reinforced concrete; corrosion; galvanic anodes; potential mapping

Paper type – Journal

1 INTRODUCTION

Patch repairs of deteriorating concrete is a common approach to rehabilitate defective concrete structures. Bridge Advice Note 35 [1] suggests that areas which show chloride concentrations greater than 0.3% by weight of cement and half-cell potential measurements higher than -350mV should be removed. Concrete replacement to this extent on chloride-contaminated structures can be very onerous and expensive [2].

Galvanic anodes have been used to limit the extent of concrete replacement and extend the service life of patch repairs to RC structures [3 – 5]. They respond to changes in the environmental conditions they are exposed to [3, 6, 7]. Such an effect will be more dominant in parent concrete that has a residual level of chloride contamination as opposed to the non-contaminated repair concrete or mortar and this has been employed to extend the use of galvanic anodes [8, 9].

This work measured the performance of galvanic anodes installed within the parent concrete around the perimeter of the repair as opposed to the traditional approach of placing the anodes within the patch repair area itself. The anodes were monitored in order to assess their performance and the results provide an improved understanding of the corrosion protection mechanism [5].

2 THEORETICAL BACKGROUND

Galvanic anodes operate on the principle of differential potentials of metals [3, 4]. A schematic illustration of a galvanic cathodic protection (CP) system is provided in Figure 1. For the protection of steel reinforcement in concrete, such electrochemically more active metals include zinc, aluminium and magnesium.

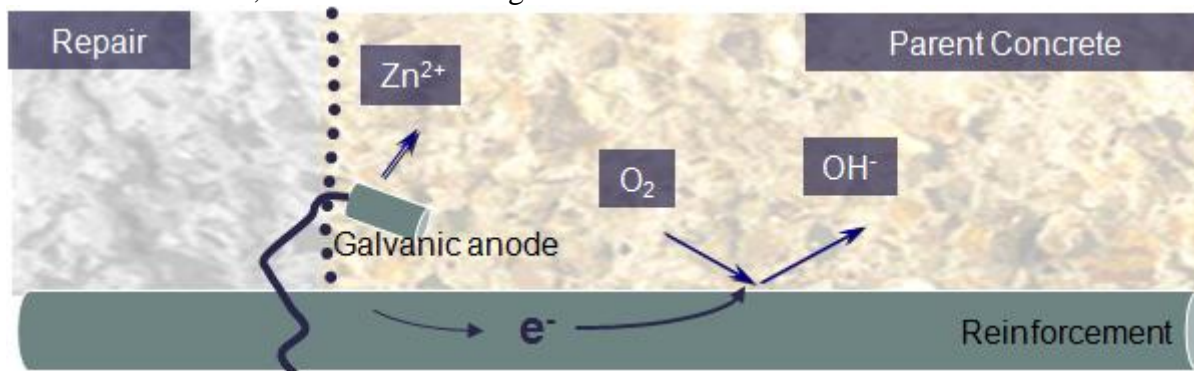

Figure 1: A compact discrete galvanic anode connected to the steel reinforcement which becomes the cathode of the galvanic cell that is formed [10].

Contemporary galvanic anode systems can be categorised as (Figure 2) [10]:

- i. Metal coatings applied directly to the concrete surface
- ii. Sheet anodes attached to the concrete surface
- iii. Distributed anodes embedded in a cementitious overlay
- iv. Discrete anodes embedded in cavities in the concrete

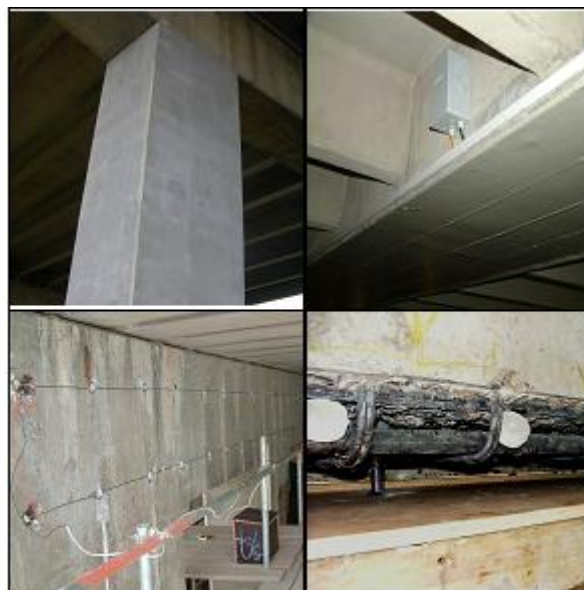

Figure 2: Galvanic anode examples (i) a thermally applied metal coating (top left), (ii) adhesive zinc sheets (top right) [4], discrete anodes in drilled holes (bottom left) [15], discrete anodes installed in patch repair (bottom right).

For galvanic anode systems, current output tends to fall with time as the anode is consumed. As a result galvanic protection is not generally achieved by sustaining an adequate level of steel polarisation, as is the case for other electrochemical treatments [9, 11].

For this reason, traditional galvanic anode systems are only installed as a corrosion prevention system and take the form of discrete anodes embedded within concrete patch repairs [3, 12]. The concrete repair process will restore steel passivity [4, 13]. Thus, embedded galvanic anodes are only required to provide a small cathodic polarisation to the steel reinforcement in the parent concrete adjacent to the repair area, which is considered to be an area of high risk [14 – 16]. This is also commonly known as “cathodic prevention” [17].

The traditional 100 mV depolarisation performance criterion for Impressed Current Cathodic Protection (ICCP) systems has also been routinely applied to galvanic anode systems [18, 19]. However, several publications note that this is not suitable for galvanic CP systems which are primarily designed to offer cathodic prevention only [9, 19 – 21]. The new International standard for CP of steel in concrete [17] has taken this into account and performance assessment of galvanic CP is preferably focused on corrosion risk assessment. In practice this is based on monitoring of changes in the condition of the reinforcement that arise as the result of the protective effects afforded by galvanic CP [11]. Examples include corrosion potential as a function of time and/or distance from an anode or edge of the repaired area and/or corrosion rate [5, 22].

There are a number of factors affecting the performance of galvanic anode systems. These are summarised in Table 1.

Table 1: Factors affecting the performance of galvanic anode systems applied to RC structures [10].

Factor	Effect
Concrete Resistivity	An increase in concrete resistivity reduces the protection current output of a galvanic anode which limits the protection delivered [3, 4, 17].
Current distribution	Discrete anodes distribute current poorly compared to surface applied anodes but protection can be targeted to the area of need [3, 4, 17].
Continuing corrosion	Products designed for use in a preventative role may fail when trying to arrest an active corrosion process [23].
Charge capacity / current output	The maximum theoretical life cannot exceed a period determined by the anode charge capacity and anode current output.
Anode activity / surface area	Determines protection current output and discrete anodes in particular need a method of anode activation. For alkali activated systems, anode activation is dependent on the quantity of alkali in the assembly.
Anode delamination / adhesion to concrete	Galvanic anode systems applied to concrete surfaces in particular are at risk of suffering from delamination and loss of contact with the concrete.

3 METHODOLOGY

This section describes the structures and the testing regime employed to evaluate the performance of the galvanic anodes.

3.1 STRUCTURES

The structures comprised a multi-storey car park (MSCP) with 11 stories in the East Midlands, UK and an 18 span bridge approximately 180 m long in Northern Scotland, UK. This MSCP was built in the early 1970s and it has a concrete one-way spanning ribbed type deck arrangement with 80 mm thick slab in-between the ribs (Figure 3). Due to the nature of the structure it was lightly reinforced with steel mesh. The bridge was also built in the early 1970s and comprised prestressed concrete beams supported on RC crossbeams with steel renhex pile supports (Figure 4). Due to the nature of dealing with full-scale structures at an age of at least 40 years, full details of the concrete composition were not available.

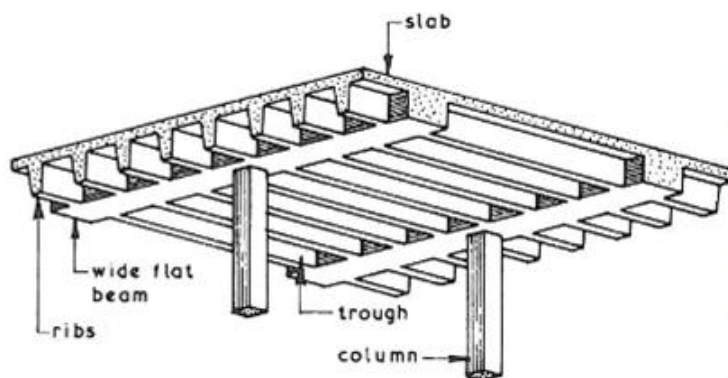

Figure 3: MSCP structural arrangement

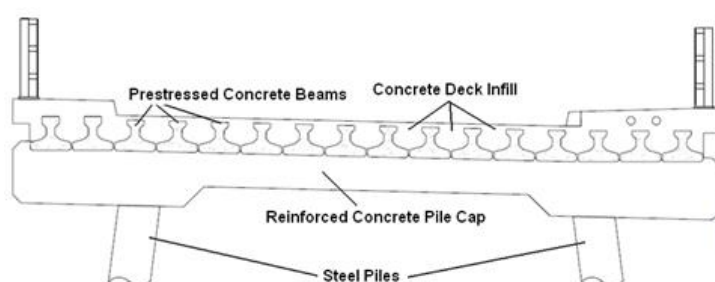

Figure 4: Bridge structural arrangement

Both structures suffered from chloride-induced corrosion [5] (Figure 5). The MSCP exhibited structural damage on the decks and soffits with exposed reinforcement and extensive concrete spalling. Chloride analysis, at more than 50 test locations on the concrete slabs and soffits of various floors, conducted in accordance with BSI [24], indicated that the chloride levels were up to 2.92% by weight of cement at a depth of 30 mm to 55 mm. This is high and presents a corrosion risk that should be addressed [1].



Figure 5: Chloride-induced corrosion and spalling to the MSCP and bridge structures (respectively)

The bridge also exhibited widespread areas of chloride-induced deterioration, being located in an aggressive marine environment. Chloride analysis testing at 12 locations on the RC crossbeams, in accordance with BSI [24], indicated high concentration levels of around 1.8% by weight of cement at a depth of 25 to 50mm - the depth at which the reinforcement is located. This is high and presents a corrosion risk that should be addressed [1].

3.2 DESIGN ARRANGEMENT

The design for the structural repairs involved removing only physically deteriorated concrete by jack hammer on the MSCP and hydro-demolition on the bridge. The breakouts extended beyond the back of the reinforcement and at a minimum additional depth equal to the aggregate size of the repair mortar plus 3 mm. The steel was cleaned by means of rotary steel wire brushes [13].

The nature of commercial contracts and their risk allocation require that a contractor uses specialist repair materials conforming to a standard. Two proprietary repair materials, labelled A and B, certified as class structural repair mortars in accordance with BS EN 1504-3 [12, 25] were applied to restore the concrete profile. Because of the nature of this study it is not possible to give an equivalent material detail to that provided in laboratory experiments, although further details may be found elsewhere [13]. Table 2 provides further material details, how and where each one was applied.

Table 2: Repair materials and location

Material	Structure type	Repair location	Properties	Application method
A	MSCP	Deck	Portland cement based, flowable, polymer modified, shrinkage compensated micro-concrete. Twenty five kilograms of material was mixed with 2.50 litres of water.	Poured and trowel finished
B	MSCP – Bridge	Soffits and vertical faces	Portland cement based, polymer modified, shrinkage compensated repair mortar containing silica fume. Water to cement ratio ranges 0.35 - 0.4.	Dry spray or hand applied and trowel finished

Galvanic anodes with a diameter of 20 mm and a length of 40 mm, each containing approximately 65 grams of zinc, were installed in pre-drilled holes of 25 mm diameter and 45 mm long in the parent concrete, as close as practically possible to the edge of the patch and then filled with proprietary backfill (Figure 6). A titanium wire integrated with the galvanic anodes made a connection to the steel reinforcement within the repair area. On the MSCP, the design galvanic anode spacing was 300 mm centres, and on the bridge structures 250 mm centres.

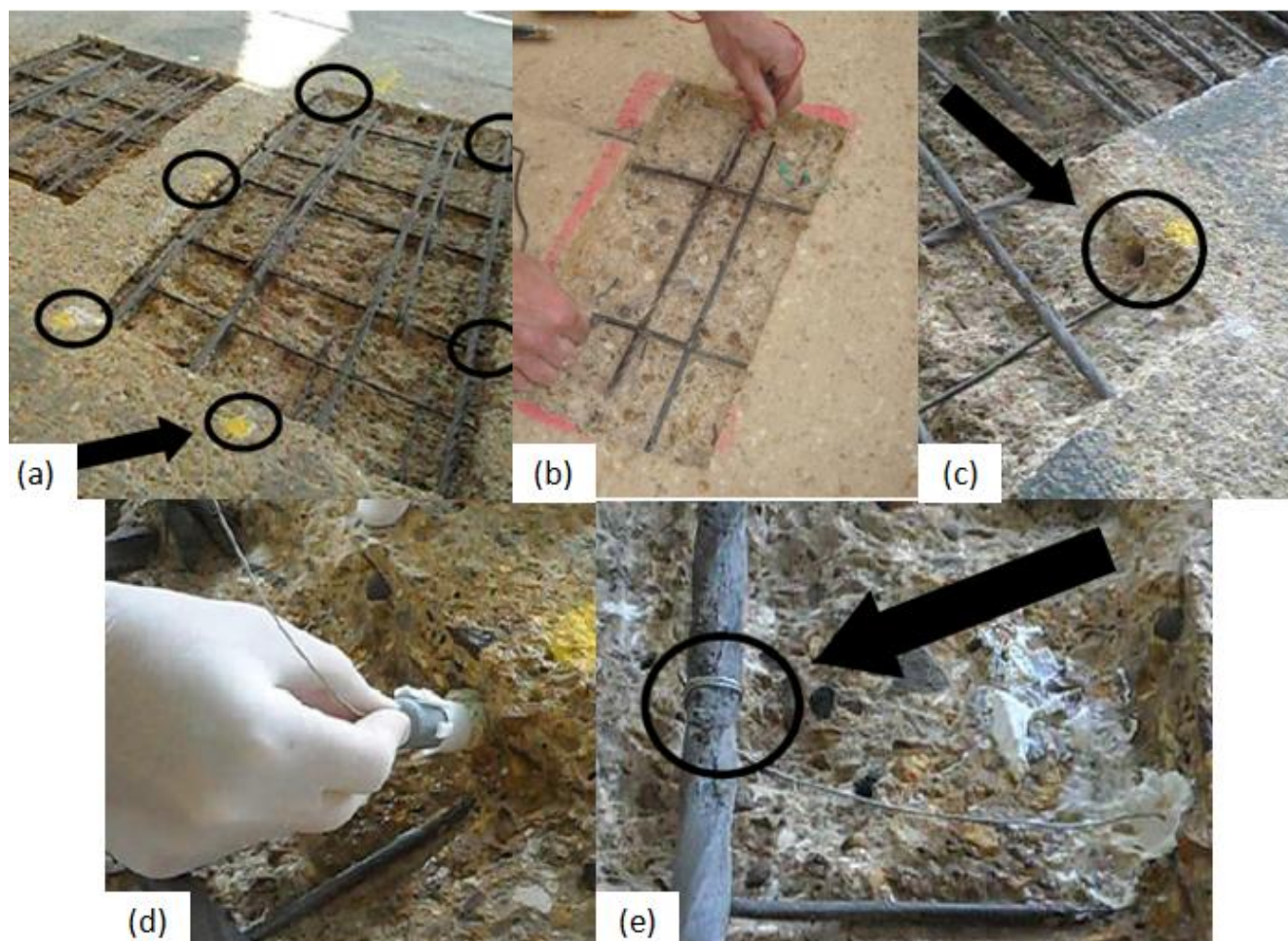

Figure 6: Galvanic anode installation procedure, (a) repair area following breakout and with location of anode installation marked out, (b) testing for reinforcement continuity, (c) pre-drilled holes for anode installation, (d) installation of galvanic anode and (e) connection of galvanic anode to the steel reinforcement and anode hole following filling with the proprietary backfill.

3.3 TESTING REGIME

Measuring steel potentials against the potential of a standard reference electrode (i.e. absolute potentials) is a well established non-destructive monitoring technique [26 – 29]. An alternative to this, are electrode to electrode potentials (i.e. relative potentials) which provide information on the electric field in concrete and as such locating areas of actively corroding steel by considering spatial variation of potentials [27, 31]. While the use of relative potential differences in reinforced concrete galvanic CP is recent, such analysis has been used for sometime in pipeline CP [28, 30].

Potential maps were obtained on a 50 mm square grid using a portable Ag/AgCl/0.5M KCl reference electrode and a high impedance multi-meter. The size of each grid varied in accordance to the size of the repair but in general it extended up to 700 mm in the parent concrete when measured from the edge of the repair. All the potential values herein are reported relative to the most positive value obtained at the time of the measurement.

In a number of areas with ease of access, the anodes were connected to the steel reinforcement with a 10 Ohm resistor bridge, in a junction box mounted at the surface of the repair (Figure 7). This arrangement was used to facilitate galvanic current densities.



Figure 7: Typical galvanic anode installation at monitoring station to facilitate galvanic current measurements.

4 RESULTS

Approximately seventy patch repairs of various sizes were monitored for both structures. In all cases examined, both for the MSCP and the bridge structure, the performance of the galvanic anodes was consistent, and similar polarisation effects were observed. For this reason, only a representative number of randomly selected repairs are reported here in order to demonstrate the range of polarisation effects afforded by the galvanic anodes in each structure examined.

4.1 MSCP

The typical polarisation effects afforded by the anodes at a distance away from the edge of the patch repair in the MSCP with material type A, between 110 and 195 days following installation are shown in Figure 8. It can be observed that the anodes affected the potentials to a distance of approximately 500 mm from the edge of the repair after 195 days. The time dependant trends observed in Figure 8 were attributed to changes in the weather conditions.

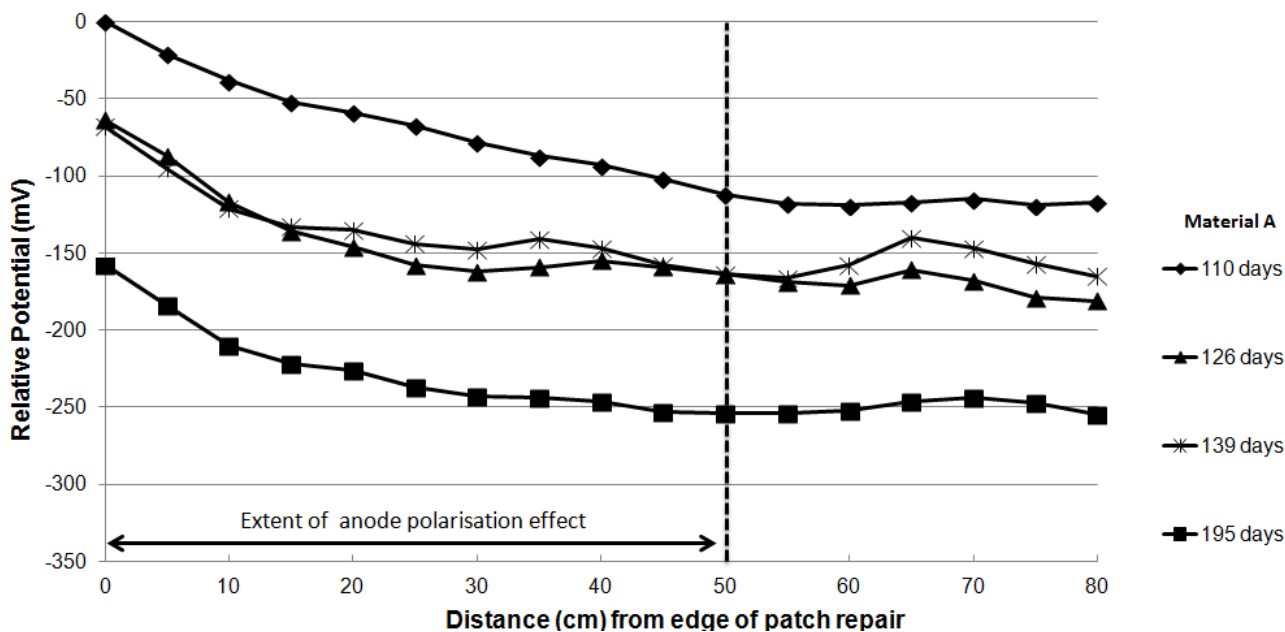

Figure 8: Polarisation effect of the anodes at a distance from the edge of a patch repair in the MSCP with material type A between 110 and 195 days following installation.

Figure 9 shows the polarisation effect afforded by the anodes at a distance away from the edge of a different patch repair in the MSCP with material type A over a period of 215 days. In this case, the anodes affected the potentials to a distance of approximately 600 mm away from the edge of the repair after 215 days.

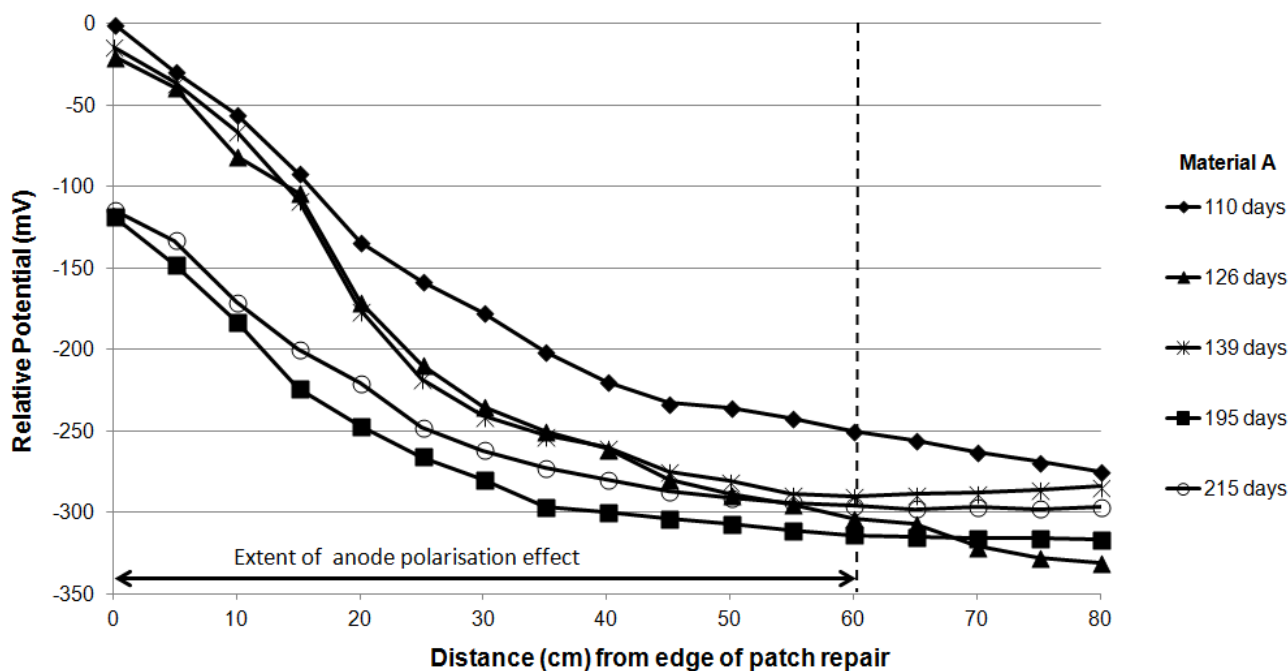

Figure 9: Polarisation effect of the anodes at a distance from the edge of a patch repair in the MSCP with material type A over a period of 215 days.

A typical repair together with a schematic illustration of the location of the galvanic anodes is shown in Figure 10. The potential mapping around this particular repair over a period of 195 days is demonstrated in Figure 11. It can be observed that the anodic points identified in the mapping, coincided at all times with the location of the galvanic anodes (anodic points have been circled over). It can be observed that the potentials never rose higher than the imaginary lines connecting the anodic spots, suggesting that there are no other anodic spots between the galvanic anodes.

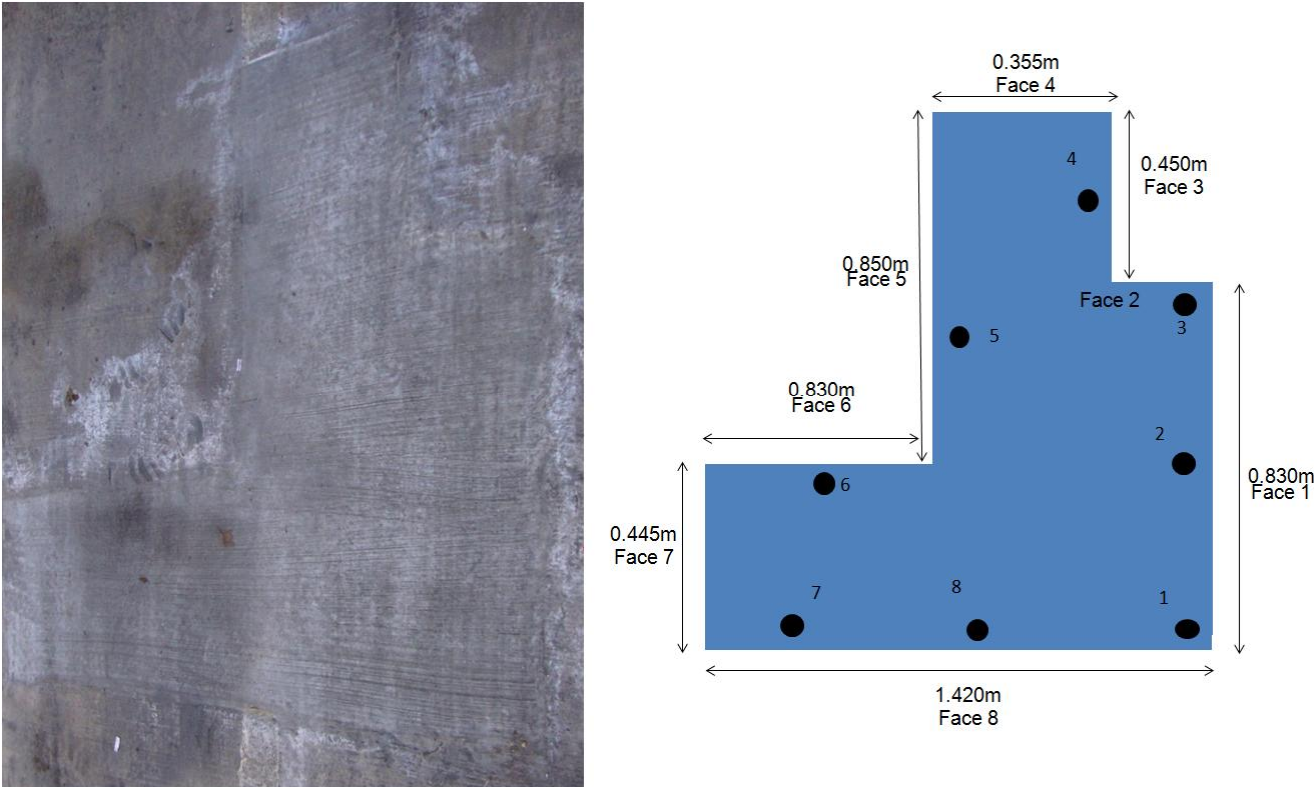

Figure 10: Typical concrete repair (left) and schematic illustration of the location of the galvanic anodes (right).

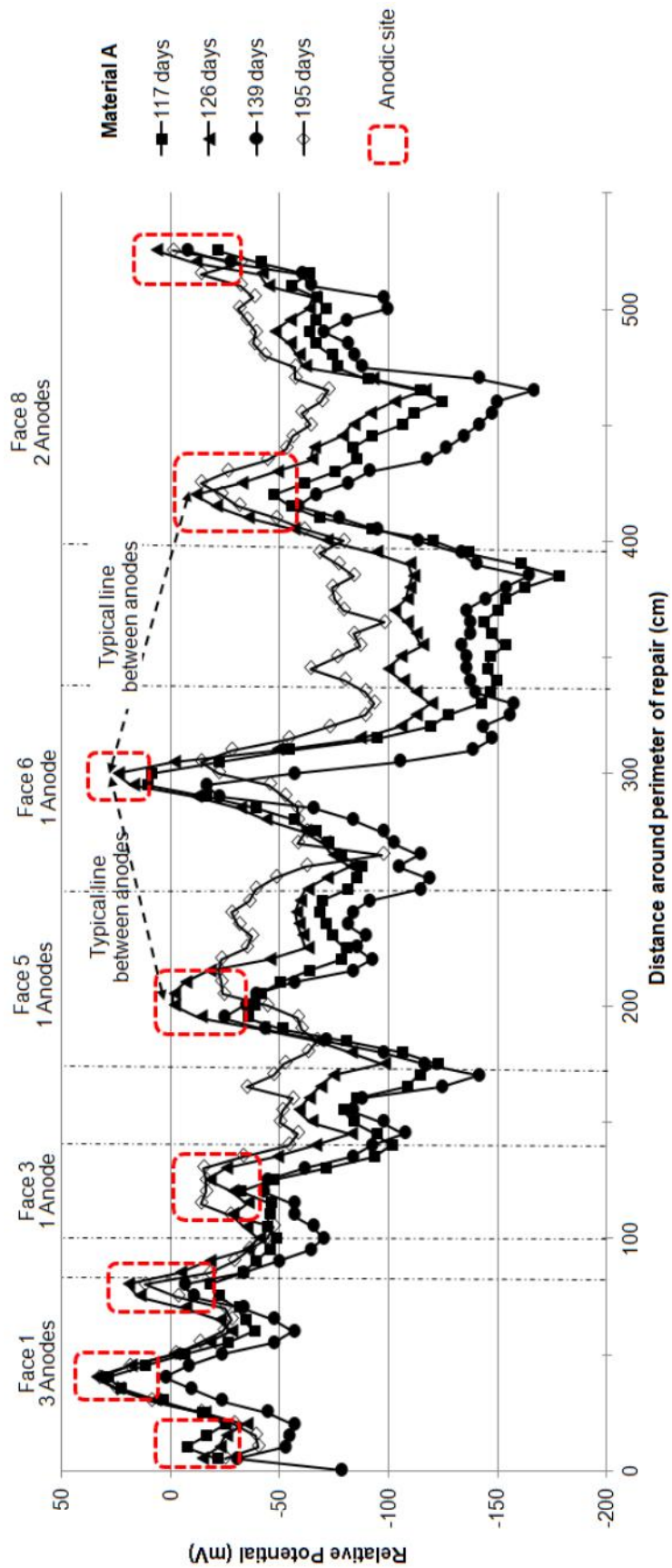

Figure 11: Potential mapping around a repair location with Material A up to 195 days following installation of the galvanic anodes.

Contour plots showing potential mapping results both before and after repairing an area of corrosion damage with material A are shown in Figure 12. The repair material had cured for 30 days when the data for the post repair contour plot was recorded. It is evident that before the repair (Figure 12 (a)), the potential in the area of the corroding steel was about 100 mV more negative than the potential in the adjacent parent concrete. 30 days after the repair this difference increased to approximately 200 mV.

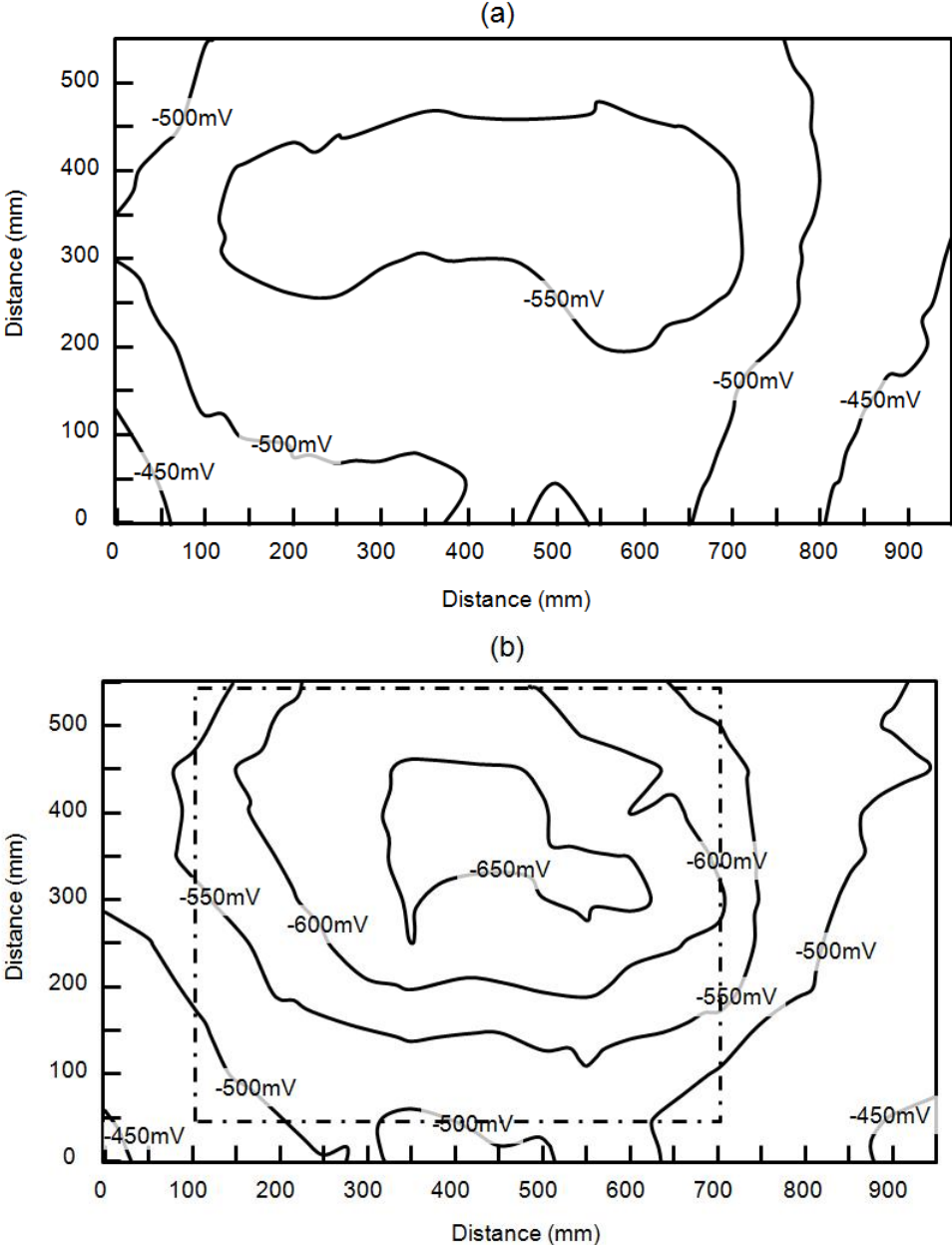

Figure 12: Surface potential mapping on car park repair with Material A (a) before and (b) 30 days after repair [13]. Dashed line in (b) illustrates extent of patch repair.

Contour plots of potential mapping following concrete replacement before and after connection of the galvanic anodes are provided in Figure 13. The application of a cementitious repair mortar initially depressed steel potentials within the patch repair to more negative values than the parent concrete (Figure 13 (a)). After the anodes were connected to the reinforcement, it can be observed that the polarisation effects afforded extended at least

250mm to the steel in the parent concrete (Figure 13 (b)) and further depressed steel potentials by close to 100 mV. The galvanic current output varied from 1.5 mA/m² to 1.0 mA/m² of steel surface area, demonstrating a responsive behaviour with time.

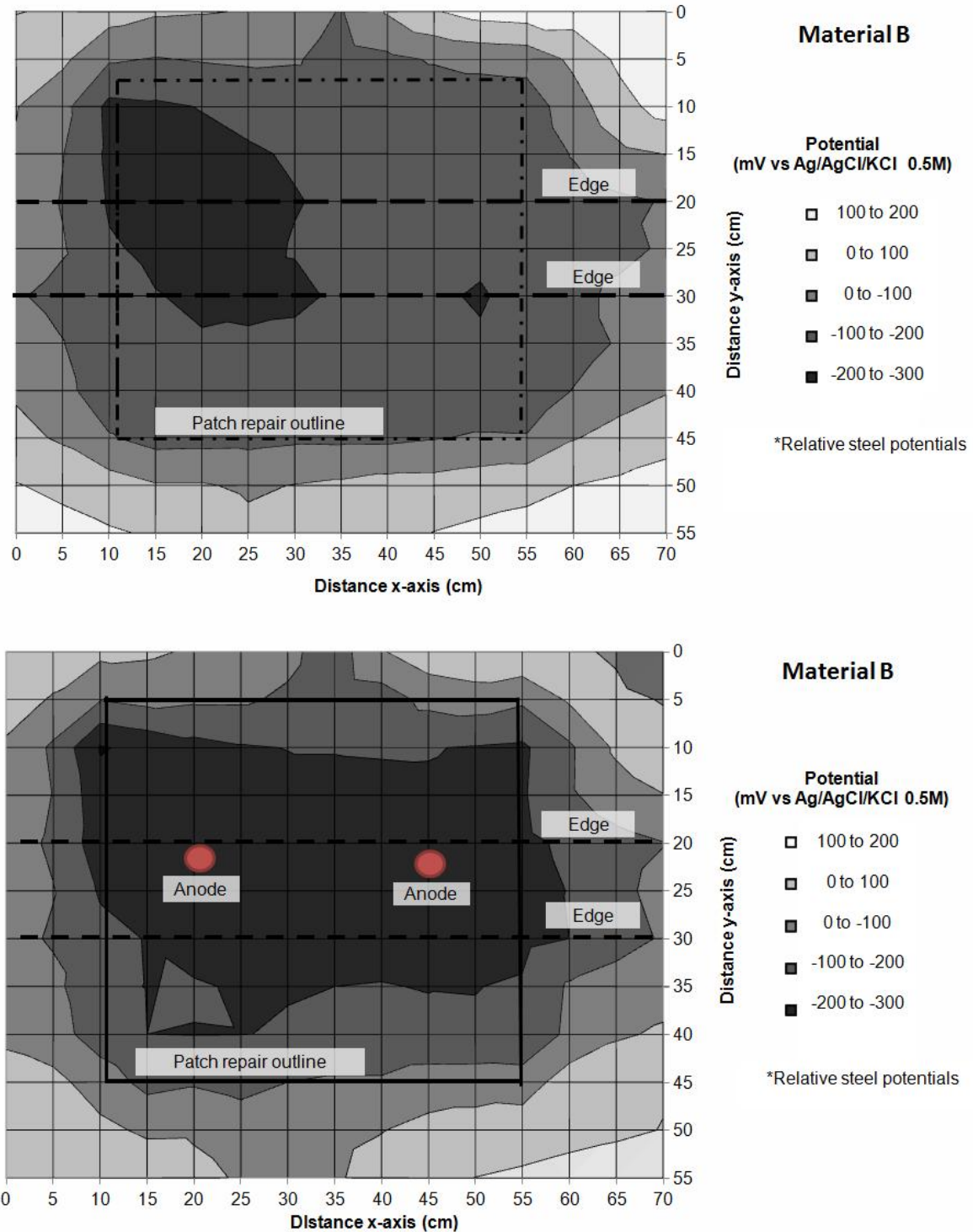

Figure 13: Surface potential mapping on car park repair with Material B (a) following concrete replacement and (b) after connection of the galvanic anodes. Dashed lines illustrate extent of patch repair.

4.2 BRIDGE

Typical polarisation effects afforded by the anodes at a distance away from the edge of the patch repair from the bridge structure with material type B, between 110 and 195 days following installation are shown in Figure 14. The anodes affected the potentials to a distance of at least 400 mm away from the edge of the repair at 30 days after their installation.

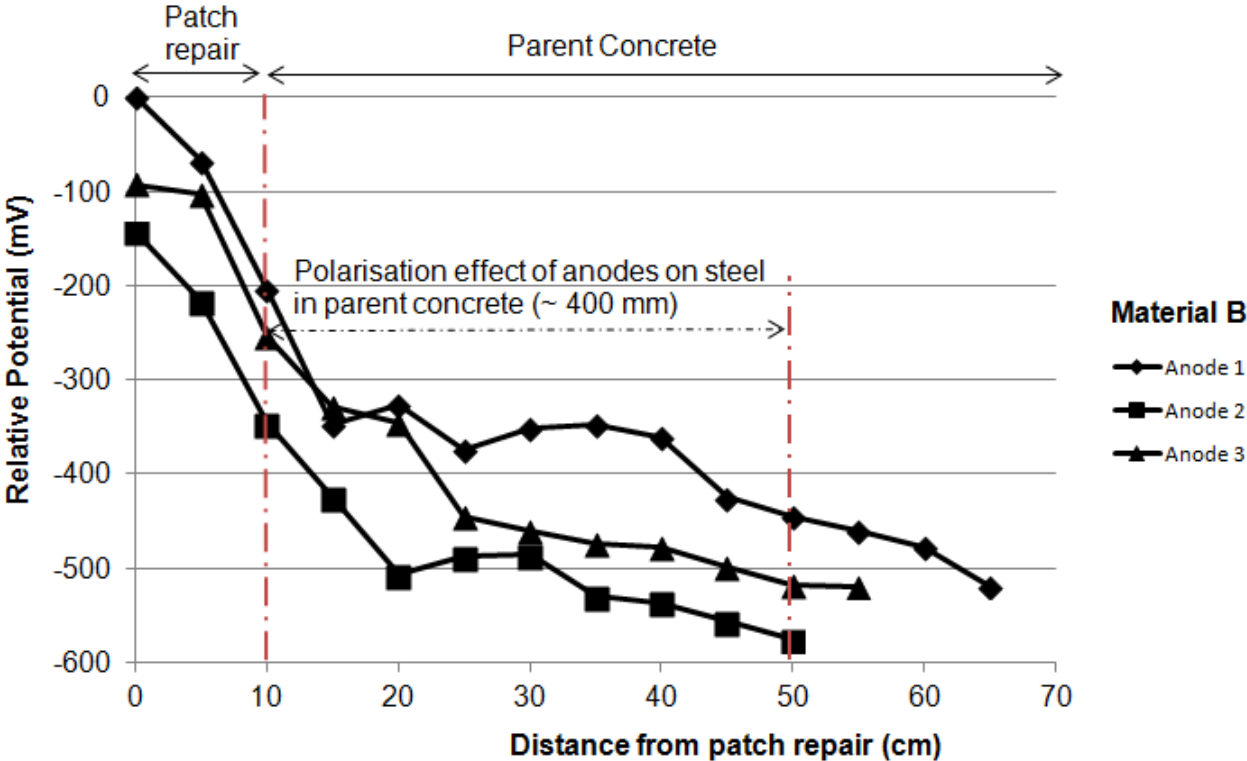

Figure 14: Polarisation effect of anodes at a distance from the edge of a patch repair from the bridge structure, with material type B, 30 days following installation.

Figure 15 shows the polarisation effect afforded by the anodes at a different repair, with material B, from the bridge structure 45 days following their installation. It can be observed that the anodes affected the steel potentials again to a distance of at least 400mm away from the edge of the repair.

From the above figures it can also be observed that the potentials of the steel in the parent concrete did not always reach a plateau, which suggested that the anodes may still be effective at greater distances. Access restraints generally restricted potential mapping on the bridge structure being generally restricted to a distance of 500 mm in length.

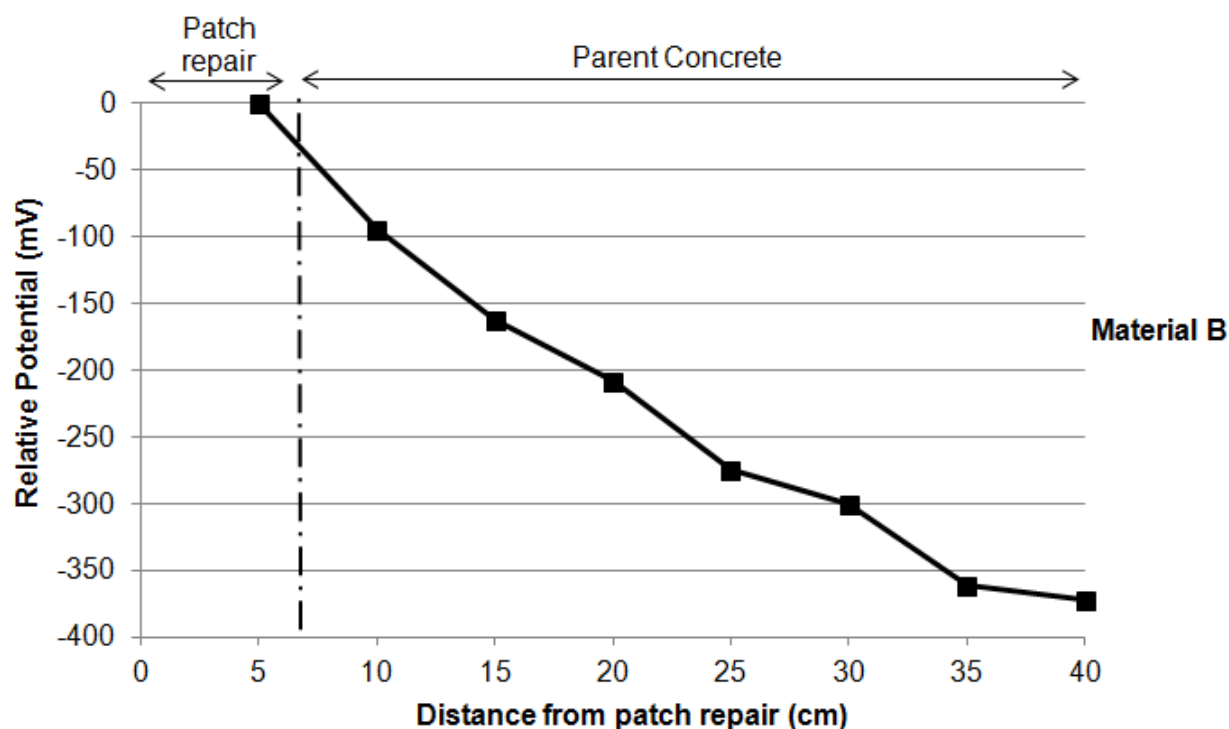

Figure 15: Polarisation effect of anodes at a distance from the edge of a patch repair from the bridge structure, with material type B, 45 days following installation.

The above, are typical and re-occurring findings on the polarisation effect afforded by the anodes to steel in parent concrete at a distance from the edge of a patch repair both for material type A and B on both structures. The exact polarisation distance varied between 250 mm and 600 mm depending on the age of the anodes, the prevailing environmental conditions at the time of testing and steel density. For the MSCP, readings could not be obtained for longer than 215 days as thereafter the slabs received a surface applied waterproofing and no longer than 45 days for the bridge structure due to access restrictions.

5 DISCUSSION

This study investigated the performance of galvanic anodes installed in parent concrete on two major RC structures in the UK. Monitoring was performed by close-interval relative potential mapping around the perimeter of the repairs to verify that the anodes were still active, and at staged distances away from the repairs to assess the polarisation effect afforded by the anodes to the steel in the parent concrete.

The performance monitoring data indicates that the galvanic anodes affected steel potentials in parent concrete as a distance away from the edge of the patch. For the MSCP, with steel mesh reinforcement only, the polarisation effect was to a distance of approximately 600 mm away from the edge of the patch. For the bridge structure, which inherently had a higher amount of reinforcing steel, the polarisation effect afforded was reduced to approximately 400 mm from the edge of the patch. This indicates that galvanic anodes have limitations and their beneficial effects are reduced with an increasing density of reinforcement.

Repair materials that conform to standards for structural repairs such as BS EN 1504 [29] did not affect the performance of galvanic anodes installed in parent concrete around the edge of the repair, although they are not generally considered suitable for use together with galvanic anodes due to their high resistivity [17]. By contrast, such materials will improve the quality and longevity of the repair itself, and due to their higher resistivity will preferentially direct current from the galvanic anodes to steel in the parent concrete, which is considered to be at higher risk.

Traditionally, half-cell potential mapping in the UK is undertaken based on a 500 mm grid and for rapid corrosion assessment spacing up to 1.2 m is occasionally employed [29]. Undertaking relative potential mapping at a small grid (50 mm), as in the case of the present study, has the advantage of collecting time-dependent spatial variation information about the condition of the reinforcement which is particularly suited to galvanic systems which are often installed without any monitoring facility (including a connection to the steel reinforcement).

A new criterion, to that of 100 mV depolarisation, may be adopted for assessing the performance of galvanic anode systems by means potential mapping to obtain spatial variations. Potential mapping around the perimeter of a patch repair with galvanic anodes installed in the parent concrete, should demonstrate that the anodes afford a dominant (i.e. be dominant over any effect of a steel anode) influence on the steel potentials away from the area of patch repair that is at least equal to half the spacing between anodes. This alternative performance criterion is also in line with the work of Holmes et al. [8].

6 CONCLUSIONS

The results of this work lead to the following conclusions:

1. Galvanic anodes installed in pre-drilled cavities formed in the parent concrete exposed within an area of patch repair can provide substantial protection to the steel reinforcement in the parent concrete outside the repair. The anodes had a dominant effect on potentials within the concrete to a distance of between 250 mm and 600 mm from the edge of the patch repair. An important factor affecting the extent of the protective effect is the steel density (quantity).
2. A repair material that conforms to standards for structural repairs such as BS EN 1504 [29] will not affect the performance of galvanic anodes installed in parent concrete around the edge of the repair. By contrast, it will improve the quality and longevity of the repair itself and will preferentially direct current from the galvanic anodes to steel in the parent concrete, which is considered to be at higher risk.
3. Close-interval potential mapping (50mm spacing) is an effective technique to assess the performance of galvanic anodes. It has the additional advantage that localised active corrosion spots can also be detected if present.
4. An alternative criterion, to that of 100 mV depolarisation, is proposed for assessing the performance of galvanic anodes: the anodes should afford a dominant (i.e. be dominant over any effect of a steel anode) influence on the steel potentials away from the area of patch repair that is at least equal to half the spacing between anodes.

ACKNOWLEDGEMENTS

The authors would like to thank AECOM and the EPSRC (through the Centre for Innovative and Collaborative Engineering at Loughborough University) for their commercial and financial support. This work was funded by the Engineering and Physical Sciences Research Council (grant no. EP/G037272/1).

7 REFERENCES

- [1] Design Manual for Road and Bridges, Volume 3, Section 3, *Part BA 35/1990 Inspection and Repair of Concrete Highway Structures*, Departmental Standard, UK.
- [2] Christodoulou C., Electrochemical treatments of corroded reinforcement in concrete. IN: Alexander, M. et al. (eds.) *Concrete Repair, Rehabilitation and Retrofitting II - Proceedings of the 2nd International Conference on Concrete Repair, Rehabilitation and Retrofitting, ICCRRR-2*, 24-26 November 2008, Cape Town, South Africa, pp. 297 – 298, ISBN 978-0-415-46850-3
- [3] NACE International Publication 01105, Item No. 24224, *Sacrificial Cathodic protection of Reinforced Concrete Elements — A State-of-the-Art Report*, Houston, USA, March 2005
- [4] Concrete Society 2011, Technical Report 73, *Cathodic Protection of Steel in Concrete*, Surrey, UK.
- [5] Christodoulou C., Glass G., Webb J., Austin S.A. Goodier C.I., A new approach for the patch repair of car parks using galvanic anodes, *Concrete Solutions 2011*, : Grantham, M., Mechtcherine, V. and Schneck, U. (eds). *Concrete Solutions 2011: Proceedings of the International Conference on Concrete Solutions 2011*. London: CRC Press, ISBN 978-0-203-13468-9.
- [6] John G., Cottis B., Laboratory Testing and Computer Modelling of the Performance of Sacrificial Anodes for use in Reinforced Concrete Structures, Paper number 03302, *Corrosion 2003*, NACE International, Houston, USA.
- [7] Christodoulou, C., Glass, G., Webb, J. 2009. Corrosion management of concrete structures, *The Structural Engineer*, Volume 87, 23/24, December 2009.
- [8] Holmes S.P., Wilcox G.D., Robins P.J., Glass G.K., Roberts A.C., Responsive behaviour of galvanic anodes in concrete and the basis for its utilisation, *Corrosion Science*, 53, pp. 3450 – 3454.
- [9] Glass G., Christodoulou C., Holmes S.P., 2012, Protection of steel in concrete using galvanic and hybrid electrochemical treatments, IN: Alexander, M.G. et al. (eds.), *Concrete Repair, Rehabilitation and Retrofitting III - Proceedings of the 3rd International Conference on Concrete Repair, Rehabilitation and Retrofitting, ICCRRR 2012*, pp. 523 – 526, ISBN 978-0-415-89952-9.
- [10] Christodoulou C., Glass G., Webb J., Ngala V., Beamish S., Gilbert P., Evaluation of galvanic technologies available for bridge structures. Presented at: *Structural Faults and Repair*, 12th International Conference, Edinburgh, UK, 10 -12 June 2008, 11pp, ISBN 0-947644-62-7.
- [11] Glass G., Christodoulou C., Towards rendering steel reinforced concrete immune to corrosion, Australasian Corrosion Association 2012 Annual Meeting, 11-14 November 2012, Melbourne, Australia, 2012, paper 159, 11p.
- [12] Concrete Society, *Repair of concrete structures with reference to BS EN 1504*, Technical Report 69, Surrey, UK, 2009.

- [13] Christodoulou C., Goodier C.I., Austin S.A, Webb J., Glass G., Diagnosing the cause of incipient anodes in repaired reinforced concrete structures, *Corrosion Science*, 69 (2013), pp. 123 – 129 DOI information: 10.1016/j.corsci.2012.11.032
- [14] Christodoulou C., Glass G., Webb J., Austin S., Goodier C., Assessing the long term benefits of Impressed Current Cathodic Protection, *Corrosion Science*, 52 (2010), pp. 2671 – 2679 DOI information: 10.1016/j.corsci.2010.04.018
- [15] Glass, G.K., Roberts, A.C., Davison, N., Hybrid corrosion protection for chloride contaminated concrete, *Proceedings of the Institute of Civil Engineers, Construction Materials*, 161 (2008) pp. 163 – 172.
- [16] Glass G.K., Reddy B., Clark L.A. 2007, Making reinforced concrete immune from chloride corrosion, *Construction Materials*, 160, pp. 155 – 164.
- [17] British Standards Institution, 2012. BS EN ISO 12696:2012, Cathodic protection of steel in concrete, London: BSI.
- [18] Bennett J., Talbot C., Extending the life of concrete patch repair with chemically enhanced zinc anodes, Paper number 02255, Corrosion 2002, NACE International, Houston, USA.
- [19] Dugarte M., Sagüés A.A., Galvanic point anodes for extending the service life of patched areas upon reinforced concrete bridge members, Contract No. BD544-09, Final Report to Florida Department of Transportation, Tampa, Florida, USA, September 2009.
- [20] Bertolini L., Bolzoni F., Cigada A., Pastore T., Pedferri P. 1993, Cathodic protection of new and old reinforced concrete structures, *Corrosion Science* 35, pp. 1633 – 1639.
- [21] Pedferri P. 1996, Cathodic protection and cathodic prevention, *Construction and Building Materials*, 10, pp 391 – 402.
- [22] Dugarte M., Sagüés A.A., Powers R.G., Lasa I.R. 2007, Evaluation of point anodes for corrosion prevention in reinforced concrete, Corrosion 2007, Paper No.07304 NACE International, Houston, USA.
- [23] Brown M. C., Sharp S. R. 2008. "Survey of Cathodic Protection Systems on Virginia Bridges" Report VTRC 07-R35, Virginia Transportation Research Council (www.viriniadot.org/vtrc/main/online_reports/pdf/07-r35.pdf).
- [24] British Standards Institution, *BS 1881-124:1988 Testing concrete, Methods for analysis of hardened concrete*, London, BSI, 1988.
- [25] British Standards Institution, *BS EN 1504:2005 Products and Systems for the Protection and Repair of Concrete Structures – Definitions, Requirements, Quality Control and Evaluation of Conformity – Part 3: Structural and Non Structural Repair*, BSI, London, 2005.
- [26] Elsener B. 2001. Half-cell potential mapping to assess repair work on RC structures, *Construction and Building Materials*, 15, 133 – 139.
- [27] Elsener B. 2003, Half cell potential measurements–potential mapping on reinforced concrete structures, RILEM TC 154-EMC: electrochemical techniques for measuring metallic corrosion, *Materials and Structures* 36, pp. 461–471.
- [28] Concrete Society 2004, Technical Report 60, Electrochemical tests for reinforcement corrosion, Surrey, UK.
- [29] American Society for Testing and Materials, 2009. ASTM C 876 - 2009, Standard Test Method for Corrosion Potentials of Uncoated Reinforcing Steel in Concrete, West Conshohocken, Pennsylvania, USA.
- [30] NACE International Standard Practice SP0207-2007, Item No. 21121, Performing Close-Interval Potential Surveys and DC Surface Potential Gradient Surveys on Buried or Submerged Metallic Pipelines, Houston, USA, 2007
- [31] Glass G.K., Davison N., Roberts A.C., Monitoring Method, UK Patent GB 2449039 B, 2010.

APPENDIX F PAPER 5

Full Reference

Christodoulou C, Goodier C, Austin S, Webb J, Glass G, Long-term performance of surface impregnation of reinforced concrete structures with silane, *Construction and Building Materials*, 48 (2013), pp. 708 – 716 DOI information: 10.1016/j.conbuildmat.2013.07.038

Abstract

Silanes can act as hydrophobic pore liners for reinforced concrete (RC) structures. They can significantly reduce the depth of chloride penetration, a major cause of steel reinforcement corrosion. However, there is little published information on their long-term performance. Thirty two concrete cores were extracted from eight full-scale RC bridge supporting cross-beams that were treated with silane 20 years ago. Their water absorption by capillarity was measured and compared with sixteen control cores extracted from four non-silane treated RC cross-beams constructed at the same time. Results show that silanes may provide a residual protective effect against water even after 20 years of service.

Keywords – Reinforced concrete; silane; hydrophobic treatment; impregnation; durability; capillary; absorption

Paper type – Journal

1 INTRODUCTION

Concrete is a naturally porous material. The size and distribution of pores in concrete varies and depends on the constituent materials, quality of compaction, the materials used in the mix design, the water-to-cement ratio, the degree of hydration, and curing [1]. Some of these pores will be interconnected to form a network of pore space that can be penetrated by water, gas or ions.

The relevant transport mechanisms for the ingress of water, gases and ions are [2]:

- i. diffusion of free molecules or ions due to a concentration difference;
- ii. permeation of gases or liquids through water saturated specimens due to hydraulic pressure difference; and
- iii. capillary suction of liquids due to surface tension acting in capillaries.

Whilst, these mechanisms act together under natural environmental exposure conditions for atmospherically exposed concrete, capillary suction tends to be the dominant mechanism [1-3]. Ions such as chlorides are transported into the concrete pore system by being dissolved into water, which subsequently cause corrosion of the steel reinforcement and ultimately spalling of the surrounding concrete cover.

Hydrophobic treatments have therefore been used in various forms in the construction industry to help prevent water and chloride ingress and their benefits are well documented [4-9]. They can be divided into three categories: coatings, pore blockers and pore liners (Figure 1).

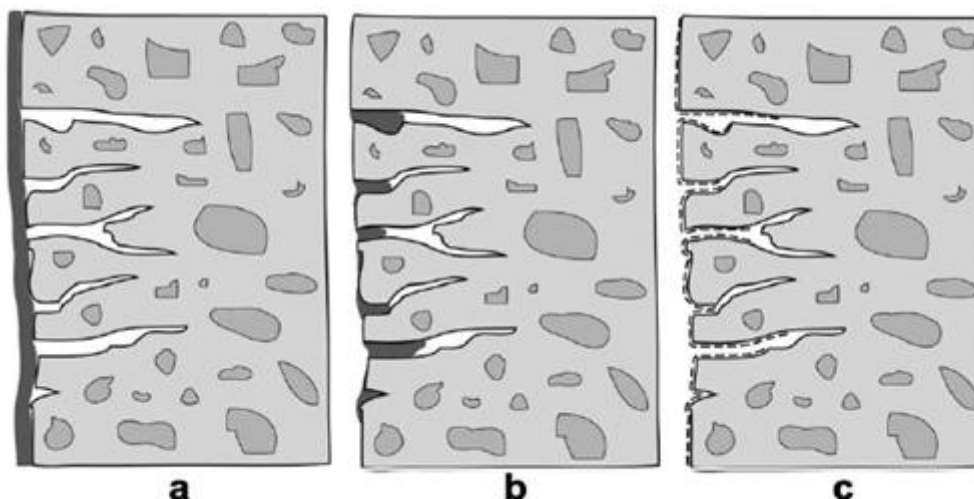

Figure 1: Categories of surface treatments a) coatings, b) pore blockers and c) pore liners [10]

Silanes belong to the pore liner category and are a group of silicones containing one silicon atom [11]. Alkoxy and alkyl silanes are routinely used for hydrophobic surface treatments. The basic composition of an alkyl alkoxy silane is shown by Figure 2. The alkoxy groups (CH_3O) linked to the silicate atom (S_i) contain silicon-oxygen bonds that will bond to silicates present in the concrete. The organic alkylic (CH_3) group remaining will protrude from the pore structure and are responsible for the hydrophobic characteristics [5-6].

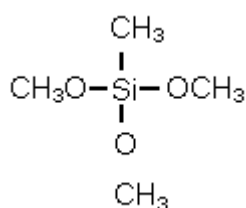

Figure 2: Typical alkyl alkoxy silane molecular structure

Evidence from numerous studies demonstrate that the application of silanes significantly reduces water uptake, which as a result reduces the ingress of chlorides and hence also reduces the corrosion risk to the reinforcement [6, 9, 12-18]. However, their performance is affected by surface imperfections, cyclic wetting and drying, skill of the applicator, surface preparation, application rates and local environmental conditions at the time of application.

Polder and de Vries [19] demonstrated that silane treated specimens still had a residual protective effect even after 5 years of outdoor exposure in the Netherlands, by measuring the water absorption and chloride content. In a similar study, Schueremans et al. [20] demonstrated the protective effects of silanes after 12 years of exposure in an aggressive marine environment on a RC quay-wall in a port in Belgium by measuring their chloride content.

Work by the Transport Research Laboratory [21, 22] in the UK indicated that silanes were reasonably effective in reducing chloride ingress into concrete structures based upon a review of principal inspection reports, various Managing Area Contractors, laboratory testing, and testing of cores extracted from full-scale motorway RC structures. The performance of the silanes was tested primarily by means of water absorption and sorptivity, but the age of silane at time of testing was limited to 5 years.

From all of the above it is apparent that very little is known regarding the durability of silane treatments and their long-term residual protection (i.e. following at least 10 years of service). Very commonly their performance is assessed by measuring chloride contamination at various depths over time. However, this is only an indirect method and does not provide information on the residual hydrophobic effect against water uptake. Extracting cores for laboratory testing from full-scale structures is neither desirable nor always feasible.

The objective of this study was to address this gap in knowledge, improve our understanding of the efficacy and long-term service life of silane treatments by undertaking testing of full-scale RC structures. The findings will help contribute towards the development of new improved corrosion management strategies and assist in a more accurate whole life cost assessment of silane treatments. The findings also provide additional information regarding the maintenance requirements of RC structures with an existing silane treatment. Early results of this work have also been reported [23].

2 METHODOLOGY

This section presents the basic theory, selection strategy for the cross-beams, the properties of the concrete investigated, and the test methods applied including their selection criteria.

2.1 CAPILLARY THEORY

The transport of chlorides into concrete is governed by a mixed mode of capillary absorption of water and diffusion. *Capillarity absorption* can be defined as the transport of liquids in porous and non-saturated solids due to surface tension acting in capillaries and without appreciable external pressure [2]. For short-term contact between the liquid and the porous solid surface, a non-steady-state transport mechanism exists. This resembles conditions encountered on site by atmospherically exposed full-scale RC structures. It can be measured as the increase in mass due to capillary water absorption as a function of the square root of time and it is usually termed as *rate of absorption*. It can be also expressed as the increase in volume as a function of the square root of time which, termed *sorptivity*.

Diffusion can be defined as the transfer of mass by random motion of free molecules or ions in a pore solution resulting in a net flow from regions of higher concentration to regions of lower concentration [2, 24].

Concrete in contact with a salt solution will become contaminated with chlorides primarily due to capillary absorption rather than diffusion alone. Absorbed chlorides can continue to penetrate by diffusion but at a significantly lower movement rate. Thus, measuring the rate of absorption (or sorptivity) can provide useful information on the condition of silane treatments.

The rate of water absorption can be expressed by equation (1) [2]. Sorptivity is the uni-axial one-dimensional capillary absorption and can be expressed by equation (2) [2].

$$\text{Rate of water absorption} = \frac{W_w}{(A_c \sqrt{t})} \quad \text{kg/m}^2/\text{h}^{0.5} \quad \text{Equ. (1)}$$

$$\text{Sorptivity} = \frac{V_w}{(A_c \sqrt{t})} \quad \text{m/h}^{0.5} \quad \text{Equ. (2)}$$

where W_w (grams) is the weight gained by the specimen, A_c (mm^2) the surface area of the specimen in contact with the water, t (seconds) the time of exposure and V_w (mm^3) the volume of water absorbed.

Measurement of water sorptivity can also be related to the rate of chloride absorption [10, 25].

Table 1 provides a summary of the European Standard BS EN 13057 [26] for measurement of the capillary water absorption of hardened concrete.

Table 1: Standard test method for the determination of water absorption of concrete

Standard	Output Properties	Testing Time	Specimen Size
BS EN 13057 [26]	Sorption coefficient $\text{kg/m}^2\text{h}^{0.5}$ or $\text{m/h}^{0.5}$ (i.e. equations 1 and 2 respectively)	Intervals of 12 min, 30 min, 1 h, 2 h, 4 h and 24 h are appropriate in most cases.	Diameter (100 ± 5) mm Length (25 ± 0.5) mm

2.2 CROSS-BEAMS

Figure 3 illustrates a typical sub-structure arrangement of the motorway bridge supporting cross-beams that were examined during this study. Silanes have been applied to a total of 135 similar cross-beams across the UK's Midland Link Motorway Viaducts (MLMV). Of these, 93 cross-beams were located in the viaduct that was chosen for these investigations, whereas the remaining were distributed amongst four other viaducts.

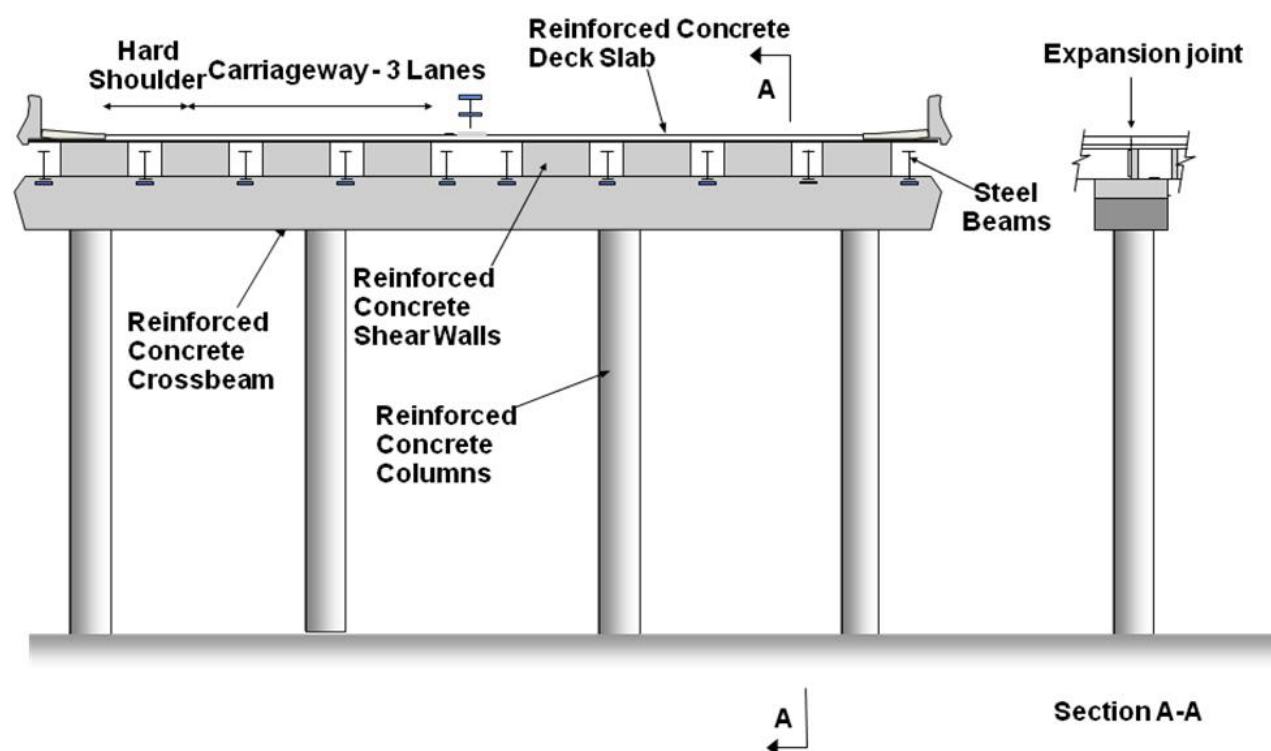

Figure 3: Typical sub-structure arrangement of the UK's Midland Links Motorway Viaducts (MLMV).

The methodological procedure employed is outlined in Figure 4. The cross-beams were constructed between 1968 and 1970, although the exact date is not known. Thus, 1969 is used as the average construction year for calculations of age of silane at time of testing. Although specimens were extracted from cross-beams of the same viaduct, hence suggesting that at least comparable concrete was used, due to the nature of construction, there will be variations in the overall concrete quality. Due to the age of the cross-beams, there were no historical records available providing information on concrete mix design such as maximum aggregate

size. Such details could have been approximated by petrographic analysis however this was consider outside the scope of the current study and would have required a large number of additional site cores.

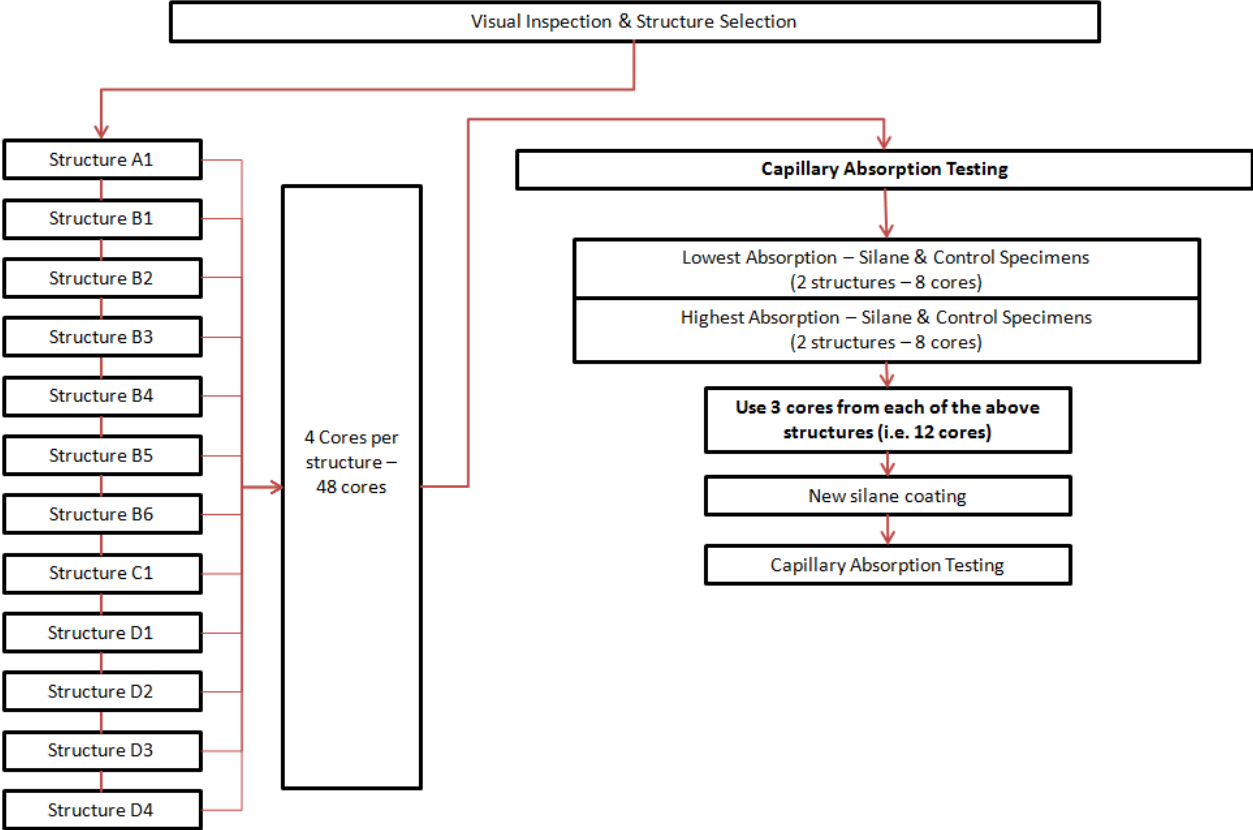

Figure 4: Selection and testing programme for silane treated cross-beams

Twelve cross-beams were selected, of which eight had previously received a silane treatment 20 years following their construction, whereas the remaining four had not, hence were acting as control specimens (Table 2). Variations in the performance of specimens extracted from the control cross-beams could give an insight with regards to site variations in concrete quality. The chemical composition of the silane treatment was isobutyl trimethoxy silane. No historical records exist detailing the exact surface preparation procedures, application rates or weather conditions at the time of the application, important factors that can affect silane performance.

Four cores (diameter and length of 80mm) were extracted from each cross-beam, all from the top surface, which represented the most critical area for water ingress (Figure 5). This residual risk can be attributed to the simply supported articulation arrangement of the bridges with carriageway expansion joints above every cross-beam that were known to be susceptible to water leakage. After coring, each core hole was carefully repaired with a shrink-resistance compensating repair mortar.

Table 2: Age of cross-beams based on an average construction date of 1969 and age of silane treatment at testing.

Cross-Beam Reference	Year of silane application	Age of cross-beam at silane application (years)	Age of silane at testing (years)	Age of cross-beam at testing (years)
A1	1991	23	20	43
B1	1993	25	18	
B2	1993			
B3	1993			
B4	1993			
B5	1993			
B6	1993			
C1	1999	31	12	
D1	Control cross beams (No silane)	-	-	
D2				
D3				
D4				



Figure 5: Coring on top of a silane-treated RC cross-beam

A correction factor in accordance with BS 1881-122 [27] was applied to normalise the cores into an equivalent of 75mm diameter and to eliminate minor differences in length between the cores as a result of the coring process (Equ.3).

$$\text{Correction factor} = \frac{V}{(A_c \times 12.5)} \quad \text{Equ.(3)}$$

where V (mm^3) is the volume of the specimen and A_c (mm^2) the surface area of the specimen in contact with water.

2.3 TESTING

A very common testing regime to evaluate the performance of silanes is to measure chloride penetration profiles between silane and control treated specimens [19, 20, 22]. One differentiating factor of this work is that this approach was not employed. The cross-beams were silane treated after approximately 20 years of service life and there were no historical records of the chloride levels at the time of silane application. As such, there would be no previous information to compare against and it was thus deemed that chloride concentration testing had limited potential for investigating the efficiency of the silane treatments and it required destructive testing of the valuable core specimens.

Investigation of the effectiveness of the silane treatment as a chloride barrier was therefore conducted by measuring the capillary absorption, a non-destructive technique. Two sets of tests were undertaken: the first on the original silane treated and control cores, the second on a subset of these to which a new silane was applied. This subset created additional background information on what could have been the potential effectiveness of silanes on aged concrete when the silanes are young. As the original silane proprietary product (based on isobutyl

trimethoxy silane) was no longer commercially available, a frequently commercially available silane product was used instead. The properties of the new silane are summarised on Table 3. In the study by Calder and McKenzie [22] it is reported as product 2.3.

Table 3: Characteristics of applied alkyl alkoxy silane treatment.

Type	Chemical type	Solid content, by weight	Flash point	Application method	Application rate
Water based silane	Alkyl alkoxy silane	20%	>93 °C	Brush applied	3 – 5 l/m ²

The procedure outlined by BS EN 13057 [26] was adopted with the following changes:

- i. The diameter of the cores was reduced to 80 mm and their length increased also to 80 mm. This change was required in order to be in a position to extract cores from full-scale RC cross-beams which are heavily reinforced.
- ii. The cores were oven dried at 35°C as opposed to the recommended 40°C. The drying temperature was lowered in order to minimise potential damage to the chemical structure of the residual silane impregnations.
- iii. The drying period was extended until the weight loss of the specimens (due to moisture loss) became stabilised to less than 0.05% weight loss over a period of 2 days, as opposed to the r not greater than 0.2% in 2 hours. This aimed to minimise any effects on the sorptivity due to initial water content of the specimens as a result of their greater length.
- iv. All but the test face (silane treated face) were sealed against sideways ingress of water and evaporation of moisture with a proprietary polysulphide sealant. This approach is in line with the recommendations of Kropp and Hilsdorf [2] in order to measure uniaxial rate of water absorption and sorptivity.
- v. The immersion depth was approximately 5mm below the water line as proposed by Hall [28] instead of 2 + 1mm. This approach does not alter the results in any way as all of the non-tested surfaces of each core were sealed against water with a proprietary polysulphide sealant.

The specimens were placed with their silane treated surface facing down in a layer of water no deeper than 5 mm (Figure 6). Their weights were recorded at 0, 5, 15, 30 minutes and thereafter every 30 minutes over a total period of 4 hours.



Figure 6: Cores sealed with proprietary polysulphide sealant for capillary absorption testing

The specimens from the best and worst performing control cross-beams were selected to form a new family of 6 specimens for additional testing with a new silane impregnation (Figure 4). The specimens received a light surface preparation to remove the build up of laitance by abrading the surface with sand paper and cleaning with an air lance. The specimens then received the new silane treatment (Table 3) and were air cured indoors for 7 days. Following, they were prepared and tested for capillary water absorption in the same procedure as the previous cores. The aim of this approach was to demonstrate the effect on the rate of water absorption for the control specimens following application of the new silane. In addition, it can provide a comparison in the performance between newly applied and old silanes.

The results for all the testing are expressed as a percentage of net weight gain for each core which is used to calculate rate of absorption (i.e. equation 1) and sorptivity (i.e. equation 2).

3 DATA ANALYSIS

This section describes the data obtained and discusses the results of the tests on the original and on the newly applied silane treatments, together with their statistical significance.

3.1 ORIGINAL SILANE TREATMENT

The net weight gain of each specimen and average for each cross-beam's group of specimens after 4 hours of testing is shown in Figure 7. It can be observed that in general the specimens exhibited variability in their performance. This may be associated with micro-structure differences of the specimens, even for the same cross-beam, as a result of lower quality control of the concrete on site possibly producing micro-structure inconsistencies. Silane treated specimens from cross-beams B5 and C1 (18 and 12 years old at time of testing) presented the lowest net weight gains.

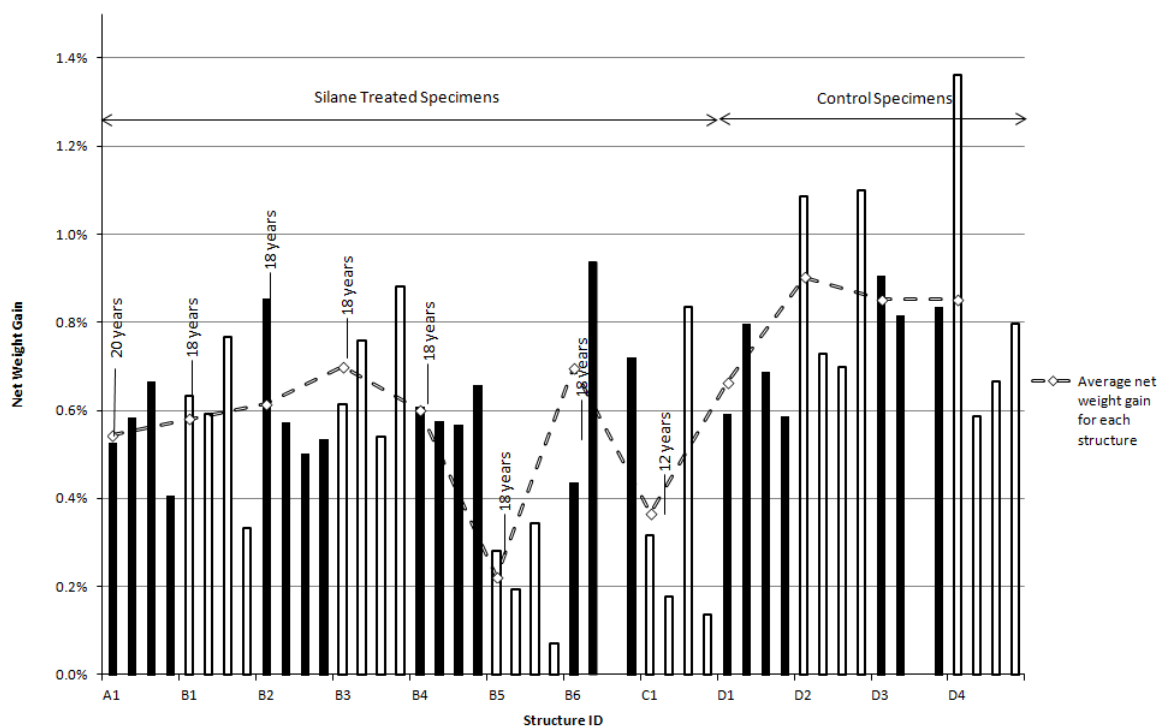

Figure 7: Net weight gain for each specimen and average net weight gain for each cross-beam's group of specimens after 4 hours of capillary absorption testing.

Note: The change in colour within the vertical bars simply differentiates specimens between different cross-beams. The age of the silane at time of testing is also noted.

The results were used to calculate average cumulative water uptake for each cross-beam's group of specimens over a period of 4 hours of capillary absorption testing, on which the rate of absorption can therefore be calculated (Figure 8). In accordance with BS EN 13057 [26], the rate of water absorption may be calculated as the linear portion of the slope or in cases where this does not exist, it may be calculated as the slope from the y-axis intercept to the last reading taken (equation 1).

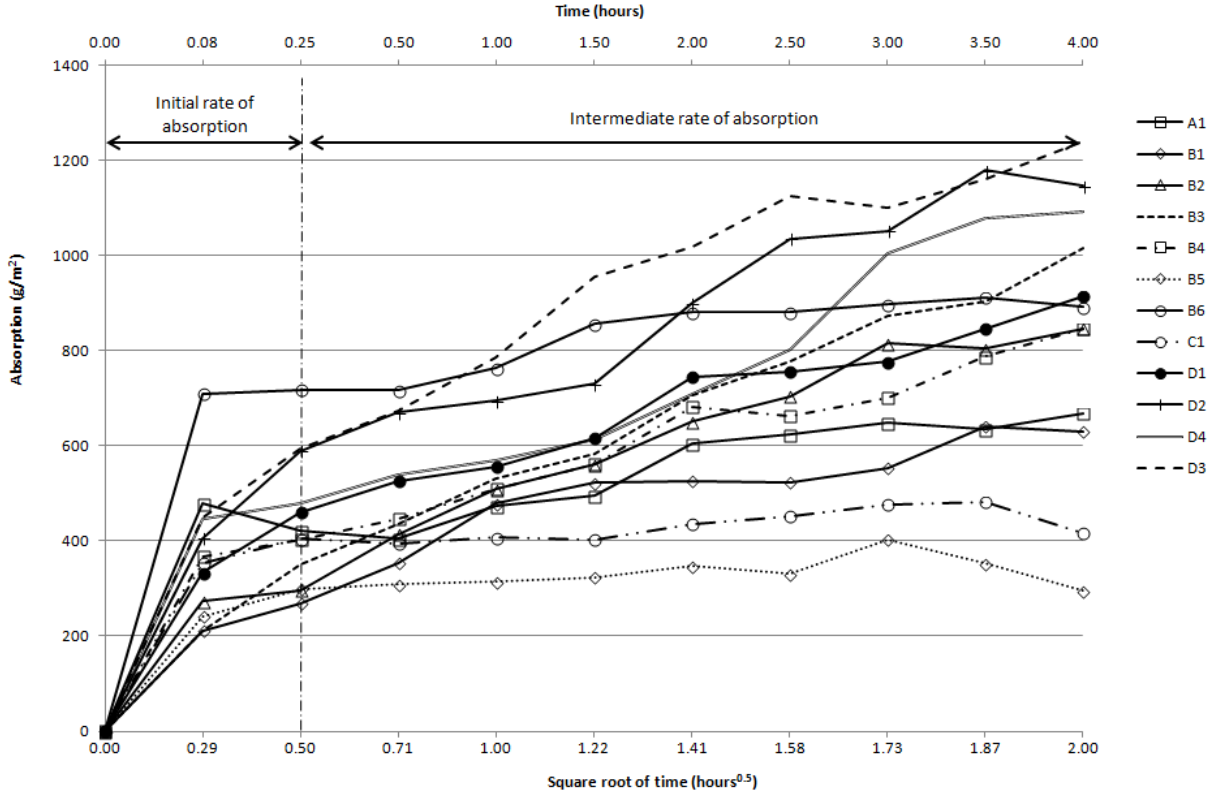

Figure 8: Average cumulative absorption for each cross-beam’s group of specimens over 4 hours of capillary absorption testing.

From Figure 8, it can be observed that specimens from all cross-beams initially had a high rate of water absorption over the first 15 minutes of testing (0.08 hours or 0.29 hours^{0.5}). After this time, for the silane treated cross-beams, in most cases the rate of water absorption was significantly reduced or almost eliminated, indicating steady state conditions. For the control cross-beams, in most cases, the rate of water absorption was reduced but never eliminated.

As such, three distinct rates of water absorption may be derived (Table 4), i.e. initial between zero and 15 mins (0 to 0.29 hours^{0.5}), secondary between 15 mins and 4 h (0.29 to 2.00 hours^{0.5}) and overall average (0 to 2.00 hours^{0.5}). Each cross-beam is ranked accordingly, to provide a more informed assessment on the relative performance of cross-beams such as B5 and C1 which had a high rate of water absorption over the first 15 minutes of testing but thereafter reached steady state conditions.

Table 4: Initial, secondary and average rate of water absorption in $\text{g/m}^2/\text{h}^{0.5}$ for each cross-beam's group of specimens based on 4 hours of capillary absorption testing.

Cross-beam Reference	Initial rate ($\text{g/m}^2/\text{h}^{0.5}$) 0 - 15 min	Ranking (High to low rate)	Secondary rate ($\text{g/m}^2/\text{h}^{0.5}$) 15 min – 4 h	Ranking (High to low rate)	Average rate ($\text{g/m}^2/\text{h}^{0.5}$)	Ranking (High to low rate)	Age of silane at testing
A1	841	6	124	9	335	9	20 years
B1	538	12	181	8	315	10	18 years
B2	593	11	275	5	423	7	
B3	703	9	332	1	507	4	
B4	805	8	221	7	422	8	
B5	599	10	26	11	148	12	
B6	1436	1	87	10	446	6	
C1	808	7	6	12	208	11	12 years
D1	920	5	227	6	456	5	-
D2	1178	3	278	4	573	2	-
D3	1188	2	323	2	620	1	-
D4	956	4	307	3	546	3	-

The variance in the rate of water absorption observed may be partly explained by changes in the micro-structure of the specimens as water progress from the cover zone (where concrete may be more porous and exhibit surface cracking) towards the core of the specimens. The thickness of this cover zone is affected by quality control on-site and curing conditions. In addition, as all the specimens were extracted from the top of the cross-beams, this effect may be exaggerated as concrete in this area will be more prone to bleeding.

It can be observed that control cross-beams D2, D3 and D4 exhibited high rates of water absorption, being in the top four worst performing cross-beams for the initial, secondary and average rates of water absorption. Although all control structures (D1, D2, D3 and D4) initially performed better than silane treated cross-beam B6, the later quickly reached near steady state conditions (refer to its secondary rate, Table 4) whereas control cross-beams continued their water absorption.

Silane treated cross-beam B3 had a very low initial rate of water absorption when compared to all other cross-beams. However, its intermediate rate of water absorption was the highest and it did not approach near steady state conditions within the 4 hours of the test. Its average rate of water absorption is comparable to that of specimens from control cross-beams and may be associated with a diminished residual hydrophobic effect.

Cross-beam C1, with the youngest silane treatment at 12 years at time of testing, was ranked average for its initial rate of water absorption but thereafter reached steady state conditions and was the best performer based on the intermediate rate of water absorption. Cross-beam B5, with the silane treatment at 18 years at time of testing, was one of the best performing based on initial, secondary and average rates of water absorption and reached near steady state conditions after 15 minutes of testing. Cross-beam A1, with the oldest silane treatment at 20 years at time of testing, was one of the best performing silane treated cross-beams.

The testing data for each cross-beam (average net weight gain, rate of absorption, sorptivity and standard deviation) following 4 hours of capillary absorption are shown in Table 5.

Table 5: Average results and coefficient of variation for each cross-beam's group of specimens after 4 hours of capillary absorption testing

Cross-beam Reference	Age of silane at testing	Net Weight Gain (%)	Coefficient of Variation	Average Rate of Absorption ($\text{g/m}^2 \text{ h}^{0.5}$)	Average Sorptivity ($\text{mm}/\sqrt{\text{h}}$)	Standard Deviation
A1	20	0.55	0.198	335	0.335	0.1014
B1	18	0.58	0.312	315	0.315	0.1113
B2		0.62	0.262	423	0.423	0.1068
B3		0.70	0.218	507	0.507	0.1101
B4		0.60	0.069	422	0.422	0.0737
B5		0.22	0.531	148	0.148	0.0926
B6		0.70	0.360	446	0.446	0.1807
C1	12	0.37	0.879	208	0.208	0.2109
D1	Control cross-beams (No silane)	0.67	0.148	456	0.456	0.1305
D2		0.90	0.244	573	0.573	0.1480
D3		0.85	0.056	620	0.620	0.0662
D4		0.85	0.410	546	0.546	0.1823

3.2 STATISTICAL ANALYSIS

From Table 5 it can be observed that in a number of cases there was a large coefficient of variation for specimens extracted from the cross-beam (e.g. B5, C1, D4). To examine the significance of this variance a simple one tail t-test was undertaken for each group of specimens based on the average, standard deviation and standard error values. For cross-beam C1 which exhibited the largest variance, the one tail t-test indicated a probability of less than 0.3% that the observed variance was a result of specimens belonging to a different family.

A statistical analysis was also undertaken to assess whether the samples of silane and control specimens belong to the sample population. For the silane treated samples the variance in sorptivity was found to be $0.0146 \text{ mm}^2 \text{ h}^{-1}$ and for the control samples $0.0075 \text{ mm}^2 \text{ h}^{-1}$. As there was a significant difference between these values the one tail t-test for unequal variances was used. The test yielded a probability of less than 3% that the observed difference between

the variance of the two samples occurring due to random effects, such as the choice of sample. As such, it is highly unlikely that there is no difference between the populations and therefore the silane treatment has an effect.

3.3 NEW SILANE TREATMENT

Cross-beams D1 and D2 were one of the best and worst performing controls. A new silane treatment was applied in order to approximate the effect of a newly applied silane treatment on the sorptivity of aged concrete extracted from full-scale RC cross-beams. Table 6 compares the sorptivity in their original untreated condition and 1 month after the application of a new silane treatment. These are in turn compared with the sorptivity of the best performing and previously treated cross-beams B5 and C1, with the silane at 18 and 12 years old respectively at time of testing.

Table 6: Comparison of control and silane treated cross-beams following the application of a new silane treatment.

Cross-beam Reference	Average Sorptivity (mm/\sqrt{h})	Comment	Average Sorptivity (mm/\sqrt{h})	Comment
B5	0.148	18 years old silane	0.148	18 years old silane
C1	0.208	12 years old silane	0.208	12 years old silane
D1	0.456	Best performing control - No silane	0.055	New silane – 1 month old
D2	0.573	Worst performing control - No silane	0.072	New silane – 1 month old

It can be observed that following the application of a new silane treatment the sorptivity for both D1 and D2 control cross-beams was significantly reduced, as would be expected. Both cross-beams demonstrated similar sorptivities indicating similar levels of hydrophobic effect afforded by the new silane treatment. Based on the originally best performing control cross-beam D1, a reduction of sorptivity of at least 90% was achieved.

When compared to cross-beam C1 with 12 year old silane at time of testing, a reduction on the sorptivity of approximately 78% was achieved. Similarly, comparing the results to the best performing cross-beam B5 with 18 year old silane, a reduction in sorptivity of approximately 70% was achieved.

The results may be associated with a reduction in the hydrophobic effect of silanes over time. In addition, the new silane treatment was applied in a laboratory environment under strict quality control conditions as opposed to site conditions where a greater variability would be expected to exist when applying surface treatments to large areas. Furthermore, the new silane treatment is a different proprietary product than the original, as the latter is no longer available, which, albeit of similar chemical composition, may also produce performance variations.

4 DISCUSSION

The results suggest that the silane treated specimens exhibited a residual protective effect even after 20 years of service life. Specimens from cross-beams B5 and C1 (18 and 20 years old respectively at time testing) were overall the best performing silane treated specimens. In particular, specimens from cross-beam C1 - which had had the most recent application - outperformed all specimens except from cross-beam B5. Possible reasons for the difference in performance between specimens of silane treated cross-beams include time dependant effects such as weathering, surface preparation, application rates, environmental conditions at the time of application and differences in the quality of the concrete. Unfortunately, no historical records exist providing these details.

The average water absorption of the specimens (Figure 8) was found to have a fluctuating rate throughout the duration of the test. This is not uncommon, especially when dealing with specimens extracted from full-scale structures [22]. The variability of concrete within site structures will generally be greater than that of laboratory cast specimens. The specimens for this study were extracted from the top of the RC cross-beams an area where concrete is predisposed to bleeding and segregation which can give rise to inconsistencies of the cover zone.

The application of a new silane treatment had a considerable hydrophobic effect on the properties of the specimens tested. Specimens from control cross-beams D1 and D2 demonstrated a reduction in their sorptivity of at least 90% following the application of a new silane impregnation. Comparing the performance of the newly silane treated specimens with that from previously treated cross-beams such as B5 and C1 provides a baseline of the likely hydrophobic effect of this type of silane on the cross-beams when they were first applied.

Figure 9 compares the sorptivity of the silane treated specimens of this study against those of Calder and McKenzie [22]. It can be observed that very similar sorptivities were recorded for the new proprietary silane and their product 2.3 applied on laboratory specimens and artificially weathered. They also evaluated the performance of other proprietary products, referenced as products 3.2 (cream based silane) and 4.1 (crystal growth pore blocker), both being at service for 4 years prior to testing and extracted from a bridge parapet and an abutment respectively. Some similarity can be observed in the sorptivity between product 4.1 after 4 years of service life and the new silane used in our study after 1 month of application. It needs to be noted that apart from differences in proprietary materials, product 3.2 was applied to RC parapets which are directly exposed to spray water as opposed to abutments where product 4.1 was applied.

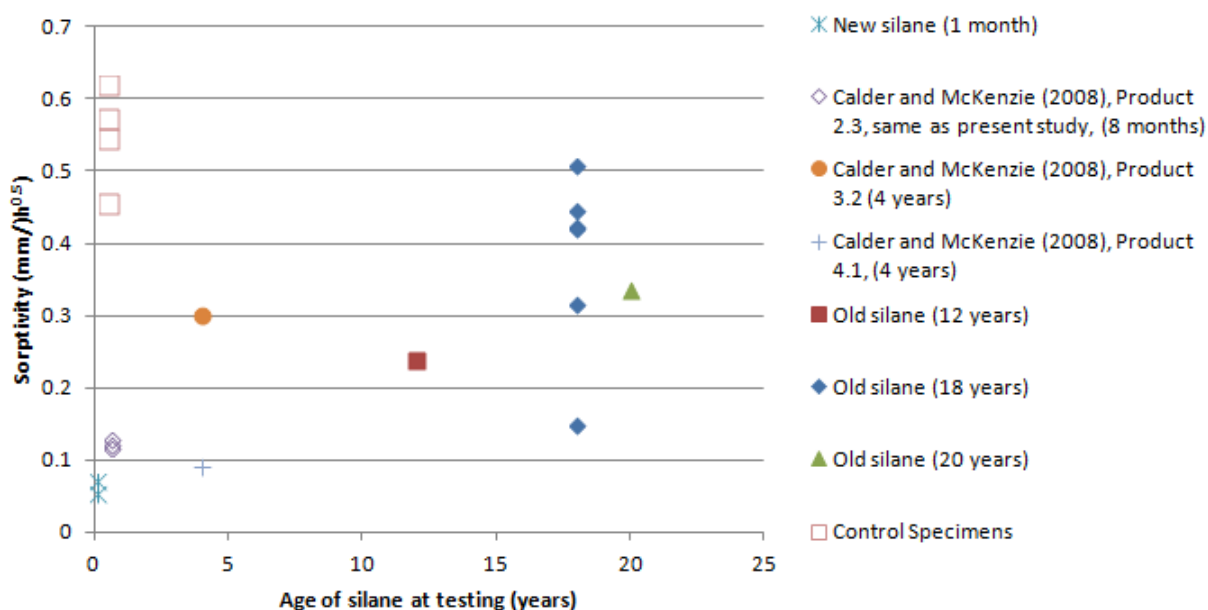

Figure 9: Comparison of the sorptivity of silane treated specimens examined in the study against the sorptivity of specimens from Calder and McKenzie [22].

Polder and de Vries [19] also undertook an assessment on the performance of silane treated specimens following 5 years of exposure to an outdoor environment in the Netherlands. However their results are not directly comparable as they obtained readings at approximately daily intervals with no readings in the first 4 hours as in the present work. Schueremans et al. [20] examined the performance of silanes from samples extracted from a full-scale RC quay wall following 12 years of service based on chloride ion concentration. Rodum and Lindland [29] undertook similar investigations with a number of proprietary products applied to a RC quay wall in Norway, measuring chloride content at various depths over a period of 10 years. Although both of those studies [20, 29] demonstrated the long-term performance of silane impregnations it is not possible to provide a direct comparison with the results of the present work.

The published data on the long-term performance of silane treatments from full-scale RC structures remains scarce. In addition, differences were found on the sampling, testing and reporting methods which hinders comparisons between the studies. Additional research is required in order to develop time dependent relationships on the performance of various proprietary silane products.

5 CONCLUSIONS

Overall, there is very little published empirical evidence that provides insight into the durability of silane treatments and their long-term residual protection (i.e. following at least 10 years of service). Such a gap in knowledge is undesirable given the scale of infrastructure treated with hydrophobic treatments such as silanes. From the results the following can be concluded:

- All the treated cross-beams demonstrated that the silane impregnation still provides a residual hydrophobic effect, even with the oldest application from 20 years ago. Statistical analysis indicated with at least 97% confidence that the variance observed between the silane treated and control specimens was due to a residual protective effect.
- In all but one cross-beam, the most recent silane treated specimens outperformed the other older silane treated specimens, suggesting that there is a relationship between degradation of the silane impregnation and duration of environmental exposure..
- Silane impregnations should be considered when determining the corrosion management strategy of a RC structure. Treatments as old as 20 years can still be present and offer a residual protective effect. Their presence and effectiveness can be evaluated by extracting cores and testing them in the laboratory by capillary absorption testing.

ACKNOWLEDGEMENTS

The authors would like to thank AECOM, the EPSRC (through the Centre for Innovative and Collaborative Engineering at Loughborough University) and the Highways Agency for their commercial and financial support. This work was funded by the Engineering and Physical Sciences Research Council (grant no. EP/G037272/1).

6 REFERENCES

- [1] Concrete Society. Technical Report 31, Permeability testing of site concrete. Surrey, UK, 2008.
- [2] Kropp J., Hilsdorf H.K. RILEM Report 12, Performance criteria for concrete durability, Taylor and Francis, Oxford, UK, 1995.
- [3] Ungricht H., Wasserhaushalt und Chlorideintrag in Beton – Einfulls der Exposition und der Betonzusammensetzung, Ph. D. Thesis (In German), Universities of Zurich and Basel, 2004.
- [4] Basheer P.A.M., Basheer L., Cleland D.J., Long A.E. Surface treatments for concrete: assessment methods and reported performance, *Const. Build Mat* 1997; 11:413–429.
- [5] Ibrahim M., Al-Gahtani S., Maslehuddin M. Almusallam A.A. Effectiveness of concrete surface treatment materials in reducing chloride-induced reinforcement corrosion, *Const. Build Mat* 1997; 11:443–451.
- [6] Vries J., Polder R.B. Hydrophobic treatment of concrete, *Const. Build Mat* 1997; 11:259 - 265.
- [7] Almusallam A.A., Khan F.M., Dulajan S.U. Al-Amoudi O.S.B. Effectiveness of surface coatings in improving concrete durability, *Cem Concr Compos* 2003; 25:381 – 473.
- [8] Yang C.C., Wang L.C. Weng T.L. Using charge passed and total chloride content to assess the effect of penetrating silane sealer on the transport properties of concrete, *Mater Chem Phys* 2004; 85: 238–244.
- [9] Medeiros M.H.F. Helene P. Efficacy of surface hydrophobic agents in reducing water and chloride ion penetration in concrete, *Mater Struct* 2008; 41:59–71.
- [10] Medeiros M.H.F. Helene P. Surface treatment of reinforced concrete in marine environment: Influence on chloride diffusion coefficient and capillary water absorption, *Const. Build Mat* 2009; 23:1476–1484.

-
- [11] Concrete Society, Technical Report 50, Guide to surface treatments for protection and enhancement of concrete, Surrey, UK, 1997.
- [12] Pfeifer D.W. Scali J. Concrete Sealers for Protection of Bridge Structures, Department of Transportation, NCHRP 244, Washington DC, 1981.
- [13] Thompson J.L., Silsbee M.R., Gill P.M. Scheetz B.E., Characterization of silicate sealers on concrete, *Cem Concr Res* 1997; 27:1561–1567.
- [14] Delucchi M., Barbucci A. Cerisola G. Study of the physico-chemical properties of organic coatings for concrete degradation control, *Const. Build Mat* 1997; 11:365–371.
- [15] Seneviratne A.M.G., Sergi G. Page C.L. Performance characteristics of surface coatings applied to concrete for control of reinforcement corrosion, *Const. Build Mat* 2000; 14:55–59.
- [16] Al-Zahrani M.M., Al-Dulaijan S.U., Ibrahim M., Saricimen H. Sharif F.M. Effect of waterproofing coatings on steel reinforcement corrosion and physical properties of concrete, *Cem Concr Compos* 2002; 24:127–137.
- [17] Moon H.Y., Shin D.G. Choi D.S. Evaluation of the durability of mortar and concrete applied with inorganic coating material and surface treatment system, *Const. Build Mat* 2007; 21:362–369.
- [18] Woo RSC, Zhu H, Chow MMK, Leung CKY and Jang-Kyo K 2008, Barrier performance of silane-clay nanocomposite coatings on concrete structure, *Compos Sci Tech* 2008; 68:2828–2836.
- [19] Polder R.B. de Vries H. Prevention of reinforcement corrosion by hydrophobic treatment of concrete, *Heron* 2001; 46:227–238.
- [20] Schueremans L., Gemert D.V. Giessler S. Chloride penetration in RC-structures in marine environment-Long term assessment of a preventative hydrophobic treatment, *Const. Build Mat* 2007; 21:1238–1249.
- [21] Calder A., Anderson N. and McKenzie M. Survey of impregnated structures. Published Project Report 136. Transportation Research Laboratory; 2006.
- [22] Calder A. and McKenzie M. Performance of impregnants. Published Project Report 362. Transportation Research Laboratory; 2008.
- [23] Christodoulou C., Goodier C., Austin S., Glass G. Webb J., Assessing the long-term durability of silanes on reinforced concrete structures, 1st International Congress on Durability of Concrete, Trondheim, Norway; 2012, ISBN 978-82-8208-031-6.
- [24] Glass G.K. Buenfeld N.R., Chloride-induced corrosion of steel in concrete, *Prog Struct Eng Mat* 2000; 2:448–458.
- [25] Austin S.A. Al-Kindy A.A., Air permeability versus sorptivity: effects of field curing on cover concrete after one year of field exposure, *Mag Concr Res* 2000; 52:17–24.
- [26] British Standards Institution, BS EN 13057:2002, Products and systems for the protection and repair of concrete structures – Test methods – Determination of resistance of capillary absorption, London: BSI; 2002.
- [27] British Standards Institution, BS 1881-122:1983, Method for determination of water absorption, London: BSI; 1983.
- [28] Hall C., Water sorptivity of mortars and concrete, a review. *Mag Concr Res* 1989; 41:51 – 61.
- [29] Rodum E. and Lindland J. Effect of different surface treatment products after 10 years of field exposure, IN: Proceedings of the 1st International Congress on Durability of Concrete, Trondheim, Norway, 17 - 21 June 2012, ISBN 978-82-8208-031-6.