

August  
2014

# The design of category N3 vehicles for improved driver direct vision

Final Report

Prepared for Transport & Environment / Transport for London

Prepared by:

Dr Steve Summerskill

Dr Russell Marshall

James Lenard

Loughborough Design School, Loughborough University

## CONTENTS

Executive Summary .....	3
1 Introduction .....	4
2 Establishing the Key Blind Spots That Should be Eliminated by Design Improvements .....	5
2.1 UK Accident Data Cluster Analysis .....	5
2.1.1 Results .....	5
3 Blind Spot Modelling .....	12
3.1 Methodology.....	12
3.1.1 SElection of the Baseline vehicle for comparison to the FKA concept and subsequent design iterations .....	12
3.1.2 Creating an Occupant Accomodation Package Within the Four Concept Designs .....	14
3.1.3 The Rationale and Design Process for the Creation of Concept Vehicles Based Upon the FKA Concept .....	17
3.1.4 EC Standards and Regulations and their Impact on Vehicle Design.....	22
3.1.5 Aperture Projections and Blind Spot Analysis .....	26
3.2 Results .....	35
3.2.1 DAF XF .....	35
3.2.2 FKA Concept.....	47
3.2.3 FKA Concept Iteration 1 – Additional Window Apertures and Modified Dashboard .....	64
3.2.4 FKA Concept Iteration 2 - Reduced cab height by 230mm .....	80
3.2.5 FKA Concept Iteration 3 - Central Driving position.....	93
3.3 Results Comparison Between Vehicle Designs .....	105
3.4 Blind Spot Map for FKA Concept Iteration 2 – With Additional Window Apertures and Reduced Height .....	112
4 Discussion of results and design related issues that have been highlighted by the analysis.....	113
4.1 What impact does the passenger seat and passenger have on the ability to use the additional side windows in FKA concept iterations 1 and 2? .....	113

- 4.2 In existing vehicles the dashboard structure contains electronic modules and other services. Can the proposed design for the reduced dash board size in concept iterations 1 and 2 include space for these vehicle components? .. 115
- 4.3 Would the removal of the dashboard structure in front of the passenger in concept iterations 1 and 2 reduce the safety of the passenger? ..... 116
- 5 Summary of Findings..... 117

## EXECUTIVE SUMMARY

Previous research has shown that existing Category N<sub>3</sub> vehicle designs exhibit considerable direct vision blind spots in front of and to the near (passenger) side of the vehicle. This research explores the potential to reduce these blind spots through changes to vehicle geometry made possible by the proposed increase to vehicle length. Using a concept vehicle designed in a project performed by FKA this research evaluates the direct vision afforded to the driver against a baseline DAF XF 105 and a range of iterations of the FKA concept to explore improvements to vision. The analyses are performed using a 3D projection technique in the SAMMIE digital human modelling system. This allows the vehicle concepts to be populated with representative drivers and visual targets including vulnerable road users in the form of pedestrians and cyclists and a typical Category M<sub>1</sub> vehicle (a passenger car).

The analysis has shown that these blind spots can be improved for the specific tests that have been performed in this research by the FKA concept and the iterations of the concept that have been produced by the LDS team.

When compared to the baseline vehicle the original FKA concept improves direct vision to vulnerable road users located at the centre of the vehicle front as the extended front effectively pushes the visual targets further away from the front of the vehicle allowing them to be seen. The visibility to the two front corners of the FKA concept and the lateral visibility through the driver and passenger doors remain problematic. The first iteration of the FKA concept reduces obscuration through the design of a compact instrument panel similar to those used in bus and coach designs. This iteration also improves direct vision to the near side and front nearside corner of the vehicle through the use of additional glazed areas. The visibility of the offside front corner is still problematic. The second iteration of the FKA concept is a modified version of the first iteration with a reduction in the cab height of the vehicle by 230mm. This results in the most successful concept analysed, with good direct vision of all of the visual targets that have been defined in the research project. This reduction in height is possible with current vehicles but would result in a vehicle with reduced off road capabilities due to a reduction in ground clearance.

The third iteration of the FKA concept explored the potential of a central driving position. This provides advantages to direct vision through improved lateral visibility at the original height of the concept vehicle. However, this iteration also introduces new direct vision issues.

The project has shown that the potential to extend the front of category N<sub>3</sub> vehicles to include aerodynamic features has some benefit in terms of improved direct vision for the design that has been analysed, but that more radical design solutions, such as lowering the vehicle cab, and adding glazed areas to the doors and below the windscreen bottom edge provide more effective solutions to the direct vision problem.

## 1 INTRODUCTION

This report documents the design and analysis of Category N<sub>3</sub> vehicles (Cat.N<sub>3</sub>) i.e. goods vehicles with a weight above 12 tonnes, with the aim of improving direct vision for the driver. An initial vehicle concept has been provided to the Loughborough Design School (LDS) team in the form of the FKA Concept vehicle. This vehicle has primarily been designed to explore the potential for additional vehicle length allowances to be exploited for improved aerodynamics and fuel efficiency. If changes were made to vehicle type approval to allow additional vehicle length, there is an opportunity for the resulting design changes to also improve direct vision.

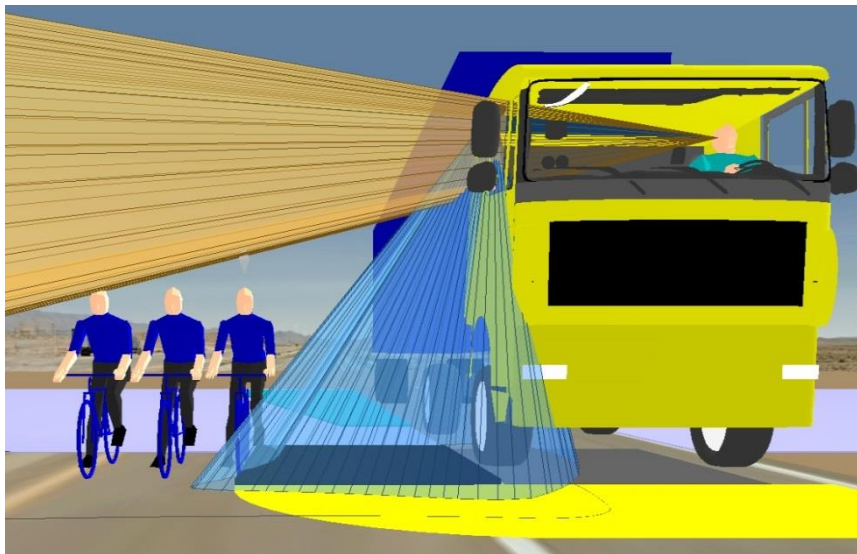

Figure 1. The blind spot adjacent to the passenger door of a heavy goods vehicle where the three average sized female adult cyclists are not visible to the driver in the mirror view or through the window

In order to explore the potential for improvements to direct vision this research has the following aims:

- To evaluate current blind spots in CAT. N<sub>3</sub> vehicles and how they correlate to accidents.
- To perform an initial analysis on the FKA concept vehicle that has been modified to include a realistic occupant accommodation model.
- To produce a number of iterations of the FKA concept to explore what changes may be made to improve direct vision with consideration of real world constraints.
- To visualise the blind spots that occur in driver's direct vision in a manner which clearly communicates the success or failure of a range of design features.

The focus of this project is the exploration of the improvement of direct vision through the windows of Cat. N<sub>3</sub> vehicles. Previous research by the LDS team<sup>1</sup>. has established that there are significant blind spots in driver vision through the combination of the windows (direct vision) and the mirrors (indirect vision). See

<sup>1</sup> Cook, S. E., et al., 2011. [The development of improvements to drivers' direct and indirect vision from vehicles. Phase 2](#). Loughborough University. Report for Department for Transport.

Figure 1 which illustrates a blind spot on the passenger side of the vehicle which can hide three UK female average sized cyclists from the driver's view.

The previous research also highlighted the issues with mirror use such as distortion of the view by curved mirrors and difficulty of use when the mirrors are dirty and in low light conditions. The project therefore focuses on the design of vehicles that improve direct vision as much as possible in order to reduce the reliance upon mirror use.

## 2 ESTABLISHING THE KEY BLIND SPOTS THAT SHOULD BE ELIMINATED BY DESIGN IMPROVEMENTS

Previous work on blind spot modelling by LDS performed on behalf of the UK Department for Transport (DfT) analysed the police accident database, STATS19, to identify all accidents involving goods vehicles (Category N vehicles) where 'vision affected by vehicle blind spot' was recorded on the database as a contributory factor<sup>2</sup>. The STATS19 database for 2008 contains 1,906 incidents with goods vehicles for which a vehicle blind spot was registered as a contributory factor. These accidents were then further filtered to remove cases where vehicles were parked, that did not make contact with another vehicle or object, or for which there was unknown or missing information. This left 704 incidents with goods vehicles in Categories N<sub>1</sub>, N<sub>2</sub> and N<sub>3</sub>.

### 2.1 UK ACCIDENT DATA CLUSTER ANALYSIS

For the 704 accidents a data mining technique known as agglomerative or hierarchical ascending cluster analysis was applied<sup>3, 4, 5, 6</sup>. Cluster analysis was used to progressively group together the most similar accidents, with the resulting clusters representing common accident scenarios.

#### 2.1.1 RESULTS

A simplified dataset formed from a selection of the fields available in STATS19 was prepared for the 704 incidents involving goods vehicles (Table 1). Where the

<sup>2</sup> Cook, S. E., et al., 2011. [The development of improvements to drivers' direct and indirect vision from vehicles. Phase 2](#). Loughborough University. Report for Department for Transport. See Section 2.3, Task 1: Accident Data, p6-13.

<sup>3</sup> Romesburg, H.C. 2004 Cluster analysis for researchers, Lulu Press, North Carolina.

<sup>4</sup> Martinez, W.L. and A.R. Martinez. 2005. Exploratory data analysis with MATLAB®, Chapman & Hall, London.

<sup>5</sup> Lenard, J., R. Danton, M. Avery, A. Weekes, D. Zuby and M. Kühn. 2011. Typical pedestrian accident scenarios for the testing of autonomous emergency braking systems, ESV paper no. 11-0196.

<sup>6</sup> Skyving, M., H-Y. Berg and L. Laflamme. 2009. A pattern analysis of traffic crashes to older drivers, Accident Analysis and Prevention 41, pp. 253–8.

categories for each field differ from those in STATS19, they were formed by aggregating categories in the source database.

Field	Type	Value	Description
Accident severity	Ordinal	0.0	Slight
		0.5	Serious
		1.0	Fatal
Vehicle type	Ordinal	0.0	LGV<3.5t (N <sub>1</sub> )
		0.5	HGV<7.5t (N <sub>2</sub> )
		1.0	HGV>7.5t (N <sub>2</sub> & N <sub>3</sub> )
Articulated vehicle	Nominal	1	Not articulated
		2	Articulated
Vehicle movement	Nominal	1	Forwards
		2	Forwards - left
		3	Forwards - right
		4	Backwards
First point of contact	Nominal	1	Front
		2	Back
		3	Right
		4	Left
Drive side	Nominal	1	Right
		2	Left
Collision partner size	Ordinal	0.0	VRU
		0.5	Motorcycle
		1.0	Car+

Table 1. Simplified dataset from STATS19 for cluster analysis of goods vehicles

The outcome of the cluster analysis is shown in Table 2. Each column describes the characteristics of a cluster. Cells highlighted in green indicate (a) that the distribution of numbers in the given field is significantly different from the distribution in the total population of the 704 incidents involving goods vehicles (chi-squared test to 99.5% significance) and (b) that the particular numbers highlighted are over-represented. Table 2 has been modified from the original to focus on specifically the larger vehicles, >7.5t that are the focus of this report.

	Cluster								Total
	1	2	3	4	5	6	7	8-11	
<b>Accident severity</b>									
Slight	168	161	97	76	54	32	27	22	637
Serious	7	7	15	1	9	2	5	5	51
Fatal	1	1	4	0	3	4	3	0	16
<b>Total</b>	<b>176</b>	<b>169</b>	<b>116</b>	<b>77</b>	<b>66</b>	<b>38</b>	<b>35</b>	<b>27</b>	<b>704</b>
<b>Vehicle type</b>									
LGV<3.5t	0	2	91	6	18	0	18	14	149
HGV<7.5t	6	14	8	11	10	5	6	2	62
HGV>7.5t	170	153	17	60	38	33	11	11	493
<b>Total</b>	<b>176</b>	<b>169</b>	<b>116</b>	<b>77</b>	<b>66</b>	<b>38</b>	<b>35</b>	<b>27</b>	<b>704</b>
<b>Articulated vehicle</b>									
Not articulated (Rigid)	17	84	116	32	66	0	35	19	369
Articulated	159	85	0	45	0	38	0	8	335
<b>Total</b>	<b>176</b>	<b>169</b>	<b>116</b>	<b>77</b>	<b>66</b>	<b>38</b>	<b>35</b>	<b>27</b>	<b>704</b>
<b>Vehicle movement</b>									
Forwards	18	0	0	0	66	38	0	6	128
Forwards - left	4	132	1	6	0	0	35	3	181
Forwards - right	154	32	1	71	0	0	0	14	272
Backwards	0	5	114	0	0	0	0	4	123
<b>Total</b>	<b>176</b>	<b>169</b>	<b>116</b>	<b>77</b>	<b>66</b>	<b>38</b>	<b>35</b>	<b>27</b>	<b>704</b>
<b>Drive side</b>									
1 Right	0	169	116	77	66	38	35	19	520
2 Left	176	0	0	0	0	0	0	8	184
<b>Total</b>	<b>176</b>	<b>169</b>	<b>116</b>	<b>77</b>	<b>66</b>	<b>38</b>	<b>35</b>	<b>27</b>	<b>704</b>
<b>Collision partner size</b>									
VRU	0	6	82	1	21	10	26	11	157
Motorcycle	1	2	16	1	10	1	6	4	41
Car+	175	161	18	75	35	27	3	12	506
<b>Total</b>	<b>176</b>	<b>169</b>	<b>116</b>	<b>77</b>	<b>66</b>	<b>38</b>	<b>35</b>	<b>27</b>	<b>704</b>

Table 2. Accident scenarios for goods vehicles

Interpreting the clusters is performed by reading each column as a scenario. For example, Cluster 1 contains 176 of the 704 goods vehicle incidents. Almost all of the vehicles (170) in cluster 1 are heavy goods vehicles over 7.5 tonnes (N<sub>2</sub> & N<sub>3</sub>). These vehicles are all left-hand drive and mostly articulated (159) (suggesting that they are LHD Category N<sub>3</sub> HGVs), were moving forwards and towards the right (154) which when taken together with Table 3 can be interpreted as side-swipe accidents to the right. Finally, the accidents were all with motor vehicles, predominately cars or larger vehicles.



	Cluster								Total
	1	2	3	4	5	6	7	8-11	
Vehicle movement									
Reversing	0	5	114	0	0	0	0	4	123
Waiting to go - held up	0	0	0	0	2	2	0	0	4
Stopping	0	0	0	0	3	1	0	0	4
Starting	1	0	0	0	20	12	0	0	33
Turning left	3	12	1	2	0	0	30	0	48
Waiting to turn left	0	1	0	0	0	0	0	0	1
Turning right	10	6	0	9	0	0	0	9	34
Waiting to turn right	1	0	0	0	0	0	0	1	2
Changing lane to left	1	117	0	2	0	0	3	2	125
Changing lane to right	138	24	1	61	0	0	0	2	226
Overtaking moving vehicle - offside	2	0	0	0	6	3	0	1	12
Overtaking static vehicle - offside	0	0	0	0	1	0	0	0	1
Overtaking - nearside	0	0	0	0	1	0	0	0	1
Going ahead left-hand bend	0	2	0	2	0	0	2	1	7
Going ahead right-hand bend	5	2	0	1	0	0	0	2	10
Going ahead other	15	0	0	0	33	20	0	5	73
<b>Total</b>	<b>176</b>	<b>169</b>	<b>116</b>	<b>77</b>	<b>66</b>	<b>38</b>	<b>35</b>	<b>27</b>	<b>704</b>

Table 3. Details of vehicle manoeuvres in accident scenarios for goods vehicles

To aid in the interpretation of the manoeuvres associated with the clusters and with the accident severity, the data were reprocessed. The results of this are shown in Table 4.

	Slight	Serious	Fatal	Total
Reversing	103	16	4	<b>123</b>
Waiting to go – held up	3	1	0	<b>4</b>
Stopping	4	0	0	<b>4</b>
Starting	22	6	5	<b>33</b>
Turning left	40	5	3	<b>48</b>
Waiting to turn left	1	0	0	<b>1</b>
Turning right	28	5	1	<b>34</b>
Waiting to turn right	1	1	0	<b>2</b>
Changing lane to left	120	5	0	<b>125</b>
Changing lane to right	220	6	0	<b>226</b>
Overtaking moving vehicle offside	10	2	0	<b>12</b>
Overtaking stationary vehicle offside	1	0	0	<b>1</b>
Overtaking - nearside	1	0	0	<b>1</b>
Going ahead left-hand bend	7	0	0	<b>7</b>
Going ahead right-hand bend	8	2	0	<b>10</b>
Going ahead other	68	2	3	<b>73</b>
<b>Total</b>	<b>637</b>	<b>51</b>	<b>16</b>	<b>704</b>

Table 4. Manoeuvre / Accident Severity for goods vehicle accidents

**Accidents due to Front blind spot**  
 These account for 16% of all KSIs and 68% involve RHD vehicles >7.5t of which 53% are Rigid, and 30% involve VRUs.

**Accidents due to Near-Side blind spot**  
 These account for 12% of all KSIs and 31% involve RHD vehicles >7.5t all of which are Rigid, and 74% involve VRUs.

**Windscreen**

**A-Pillar Blind Spot**  
 This area is hidden to the driver due to the A-Pillar. There is one on both sides of the vehicle.

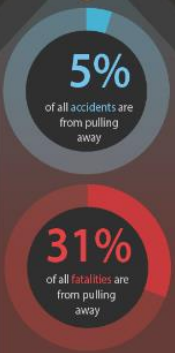

**Front Blind Spot**  
 This area is hidden to the driver due to the front structure of the vehicle.

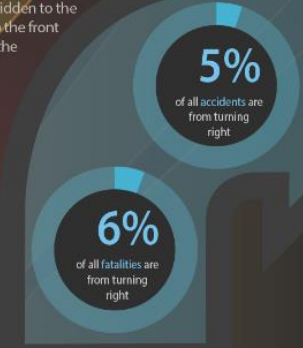

**Near-Side Blind Spot**  
 This area is hidden to the driver due to the passenger's door.

**Class V**

**Off-Side Blind Spot**  
 This area is hidden to the driver due to the driver's door.

**Side Windows**

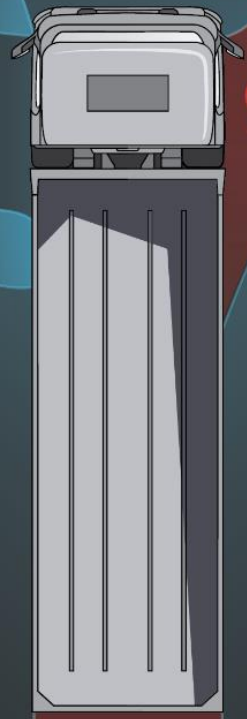

**Class II and IV**  
 This area is visible to the driver through a combination of the Class II and IV mirrors.

**Class II and IV**  
 This area is visible to the driver through a combination of the Class II and IV mirrors.

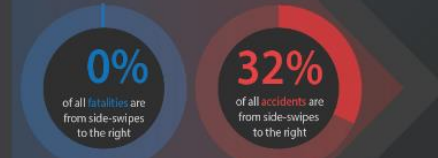
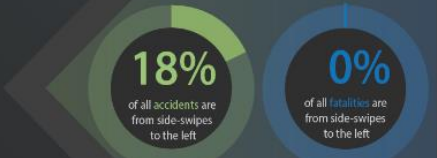

**Accidents due to Near-Side blind spot**  
 These account for 7% of all KSIs and 91% involve RHD vehicles >7.5t evenly split between Rigid and Articulated vehicles. 4% involve VRUs.

**Rear Blind Spot**  
 This area is hidden to the driver from a combination of vehicle cab and body / trailer.

**Accidents due to Off-Side blind spot**  
 These account for 9% of all KSIs and 61% involve LHD vehicles >7.5t of which 90% are Articulated. 38% involve RHD vehicles >7.5t of which 64% are Articulated. VRUs are almost never involved.

**Direct Vision**  
 These areas are visible to the driver through the windows of the vehicle.

**Indirect Vision**  
 These areas are visible to the driver through mirrors. The views afforded to the driver will be distorted to a greater or lesser degree by the radius of curvature of the mirror.

**Blind Spot**  
 These areas are not visible to the driver. They occur due to obscuration from the structure of the vehicle. In some cases the driver can 'look around' the blind spot, such as that caused by the A-Pillar. However, some blind spots such as the **Near-side** and **Rear** cannot be seen regardless of what the driver does.



**Accidents due to Rear blind spot**  
 These account for 30% of all KSIs and 14% involve RHD vehicles >7.5t; all of which are Rigid, and 71% involve VRUs.



# Goods Vehicles Accidents Due to Blind-Spots

KSIs: Killed and Seriously Injured  
 Rigid / Articulated: Vehicle body / trailer type  
 RHD / LHD: Right / Left hand drive  
 VRU: Vulnerable road users - pedestrians, cyclists etc.

The Figure above combines all of the STATS 19 analysis into a single 'infographic'. From the figure, the following can be interpreted:

- i. 5% of all accidents are from vehicles pulling away but these result in 31% of all fatalities. 68% of these accidents involve right hand drive (RHD) vehicles >7.5t of which 53% are Rigid (Tippers, Cement Mixers etc.), and 30% involve Vulnerable Road Users (VRUs).
- ii. 7% of all accidents are from vehicles turning left and result in 19% of all fatalities. 31% of these accidents involve RHD vehicles >7.5t of which all are Rigid, and 74% involve VRUs.
- iii. 18% of all accidents are from vehicles changing lane to the left but result in no fatalities. 91% of these accidents involve RHD vehicles >7.5t with an even split between Rigid and articulated vehicles, and 4% involve VRUs.
- iv. 32% of all accidents are from vehicles changing lane to the right but result in no fatalities. 62% of these accidents involve left hand drive (LHD) vehicles >7.5t of which 90% are articulated. 38% of these accidents involve RHD vehicles >7.5t of which 64% are articulated. VRUs are almost never involved.
- v. 17% of all accidents are from vehicles reversing and result in 25% of all fatalities. However only 14% of these accidents involve RHD vehicles > 7.5t, all of which are Rigid. 71% involve VRUs.

These scenarios provide a number of insights. Side-swipe accidents from lane-change manoeuvres constitute 50% of all accidents and are dominated by larger vehicles >7.5t (N<sub>2</sub> and N<sub>3</sub>) of both RHD and LHD. However, the accidents generally do not result in fatalities and almost entirely involve collisions with motor vehicles and not VRUs. To reduce these types of accidents direct vision of the blind spots to the immediate left / right of larger vehicles should be addressed.

Reversing results in a large number of fatalities (25%), most of which (71%) are with VRUs. However, only 14% involve larger vehicles >7.5t.

Pulling away results in only 5% of all accidents, but 31% of fatalities. A significant number (68%) involve larger vehicles >7.5t and 30% involve VRUs. Whilst many of these accidents involve accidents with motor vehicles, the accidents result in a disproportionate number of fatalities. To reduce these types of accidents direct vision of the blind spots to the immediate front of larger vehicles should be addressed.

Turning left results in 7% of all accidents and 19% of fatalities. Of all accident types turning left has the greatest proportion of accidents involving VRUs (74%) and 31% involve larger vehicles >7.5t. To reduce these types of accidents direct vision of the blind spots to the driver side of larger vehicles should be addressed.

The results of the analysis of accident data therefore suggest that critical blind spots exist to the front and side of category N<sub>3</sub> vehicle cabs. These areas have been

shown to include blind spots identified in previous research (see footnote 1 and Figure 1) but are also supposed to be covered by the field of view provided by the range of mirrors that are fitted to heavy good vehicles as per the regulations defined by UNECE regulation 46. Figure 16 shows the view from the interior of the vehicle to the passenger side. This view shows that there are four mirrors which can be used to see what is directly in front of the vehicle (using the Class VI mirror), directly adjacent to the passenger door and 2m away from it (using the Class V mirror), laterally down the side of the vehicle using the Class II mirror and the wide angle Class IV mirror. The Class II and Class IV mirrors are also present on the driver side of the vehicle. An issue that needs further research in the understanding of accident causation is how driver behaviour and experience varies when interacting with the six mirrors. These mirrors must be used in combination with direct vision through the windows to provide the driver with situational awareness, i.e. an understanding of the location of obstacles, VRUs or vehicles.

Put simply there is a time period associated with each mirror observation. If the driver examines the class II mirror and Class IV mirror, and then the Class V mirror and the Class VI, followed by observations through the windows before pulling away from a junction, enough time has elapsed since the first observation of the Class II for the situation to have changed. For example, if this time period is four seconds, this is enough time for a cyclist to undertake the HGV, with the driver being unaware of his or her presence.

Research should be performed which establishes how drivers interact with the six mirrors, and if the requirement to examine six mirrors to achieve situational awareness is actually achievable in high workload situations.

In any case the combination of the difficulty in scanning multiple mirrors, the distorted image that they provide, and difficulty in using the mirrors in low light conditions means that improving the ability of drivers to see obstacles directly through windows is recommended.

In the following section the methodology that is used to examine the direct vision of the baseline vehicle and a range of concept designs is described.

## 3 BLIND SPOT MODELLING

### 3.1 METHODOLOGY

#### 3.1.1 SELECTION OF THE BASELINE VEHICLE FOR COMPARISON TO THE FKA CONCEPT AND SUBSEQUENT DESIGN ITERATIONS

Previous research performed by the LDS team involved the analysis of the blind spots associated with three of the top five selling Category N<sub>3</sub> vehicles in the UK based upon SMMT sales data from 2009. These vehicles were the DAF XF, the SCANIA R and the VOLVO FH. These vehicles were analysed to determine which would be most suitable for the baseline comparison to concept vehicles shown in section 3.1.2. The method used to select the baseline vehicle involved the identification of the vehicle with the largest glazed area with the rationale that the concepts would then be compared to this vehicle.

This was done using a method which reflects the three dimensional nature of the problem being described. This involves the projection of the window apertures on the surface of a sphere at a set distance away from the driver's eyes as this provides a truly three dimensional approach to the analysis of direct vision ability. An example of this is shown in Figure 2 where the window aperture projections have been intersected with the surface of sphere set 10m away from the driver's eye point. The area of the projections on the surface of the sphere can be instantaneously calculated.

Figure 2 and Table 5 shows a comparison between three vehicles in order to show which has the largest glazed area.

The results of the analysis show that the DAF XF has window apertures which cover an area of 257.85 m<sup>2</sup> when projected onto a sphere that is 10m away from the driver's eye point. This is larger than the values for the Scania R and Volvo FH, and so the DAF XF was selected as the baseline vehicle.

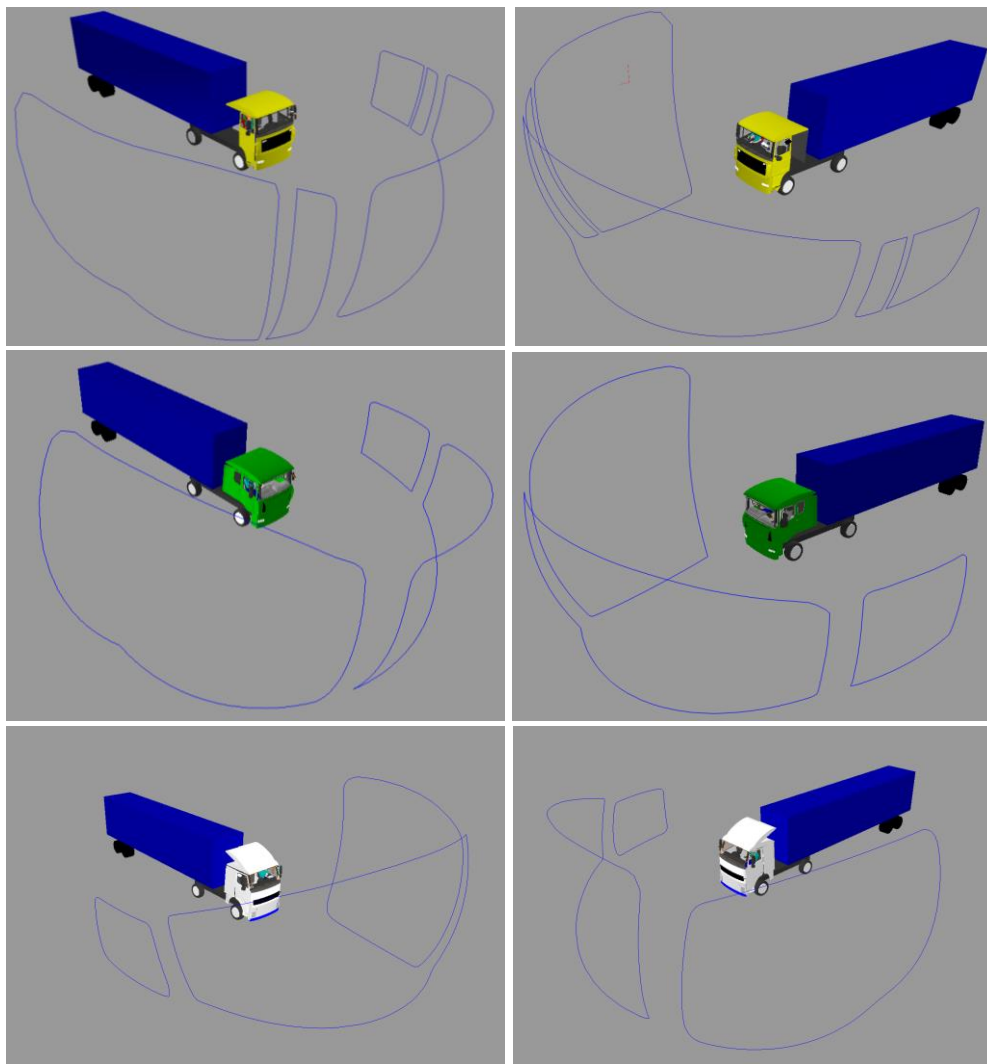

Figure 2. The spherical projection tool in the DHM system being used to quantify the surface area of a sphere visible to the driver as an objective measure of blind spot size. From top images DAF XF 105, middle images Scania R420, bottom images Volvo 480 LHD

The area of surface of a sphere 10m from the drivers ocular point visible through window apertures (m <sup>2</sup> )	Volvo FH	Scania R	DAF XF
Windscreen	98.76	79.97	101.63
Passenger door window large	13.79	14.35	9.56
Passenger door window small	N/A	N/A	3.17
Driver door window Large	106.65	136.68	127.95
Driver door window small	N/A	N/A	15.54
Total area visible through all window apertures	219.2m <sup>2</sup>	231.33 m <sup>2</sup>	257.85 m <sup>2</sup>
Percentage of visible area compared to the baseline DAF XF 105	85.5%	89.7%	100% (Baseline)

Table 5. The results of the comparison between the three vehicles showing how the best in class can be compared to other vehicles on a percentage basis

### 3.1.2 CREATING AN OCCUPANT ACCOMODATION PACKAGE WITHIN THE FOUR CONCEPT DESIGNS

The FKA concept design (see Figure 4) has been provided to the LDS team as a starting point for a design process that aims to highlight opportunities in Category N<sub>3</sub> vehicle design which can improve the ability of the driver to identify VRUs and other road users with direct vision.

The FKA concept required the addition of an occupant accommodation model, that is, the selection of a location with the cab space in which to locate the seat, steering wheel and pedals that allow the vehicle to be driven. This was a critical stage in the design process for each concept as the occupant accommodation model defines the eye point of the driver which is subsequently used to quantify the size and location of blind spots in direct vision.

In order to provide a realistic occupant accommodation model for the FKA concept a donor vehicle (DAF XF 105) was selected with the aim of recreating the seat and steering wheel adjustability and the location of pedal surfaces. The data from the DAF XF 105 was gathered in previous work (Cook et al, 2011) using a FARO contour scanner resulting in the accurate measurement of the required variables to allow the occupant accommodation model to be recreated. These variables included;

- The h-point point envelope of the driver's seat which was derived by using the SAE H-point manikin to allow the lowest rearmost, lowest foremost, highest rearmost and highest foremost seat positions to be captured
- FARO probe paths describing the seat surface, pedal locations, and steering wheel adjustability range
- FARO probe paths which describe the dash board and instrument panel structure

These data were processed in the CAD package, PTC Pro Engineer to provide polygon based data for use in the Digital Human Modelling system. Figure 3 shows the data captured using the FARO point probe.

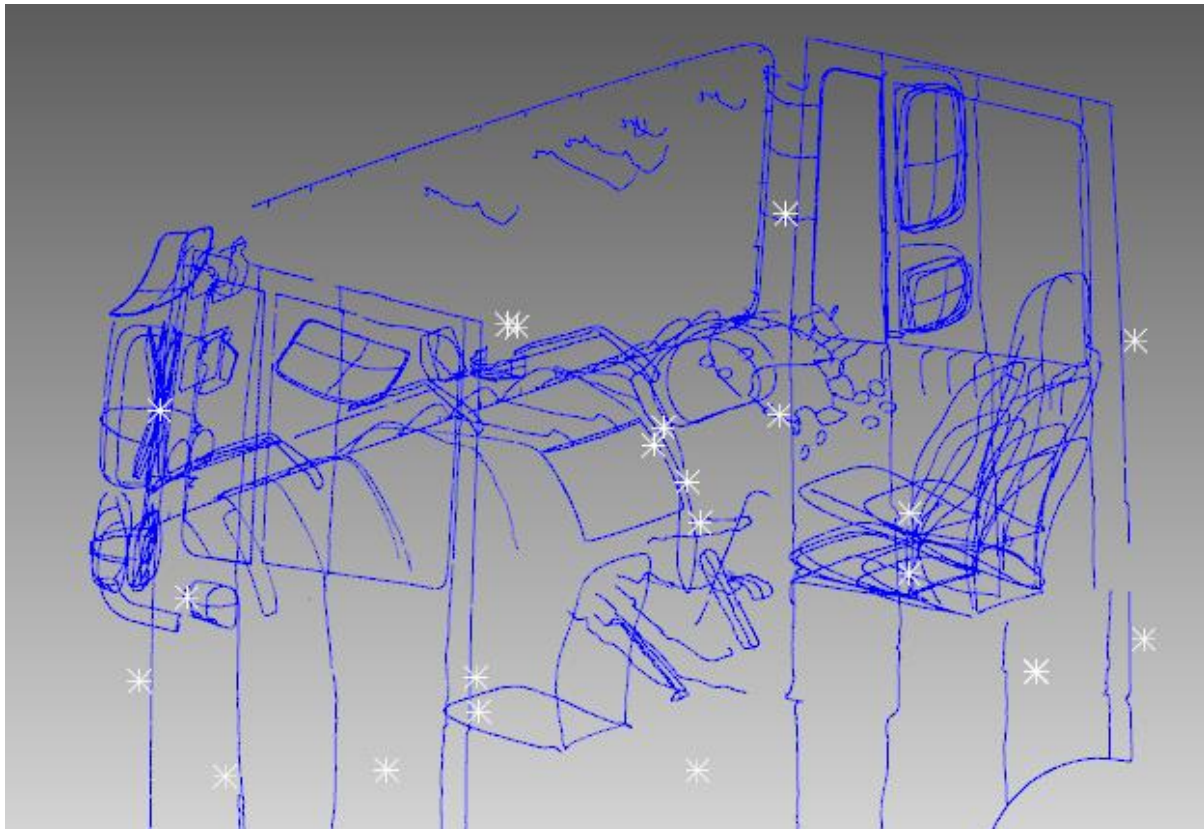

**Figure 3. The data gathered using the FARO point probe to allow the DAF XF 105 occupant package to be recreated**

The occupant accommodation package was recreated in the SAMMIE DHM system and populated with three digital human models which allow the range of potential driver eye positions to be explored. These digital human models were based upon anthropometric data gathered from professional HGV drivers with a large stature (99<sup>th</sup>ile UK male), an average stature (50<sup>th</sup>ile UK male), and a small stature (4<sup>th</sup>ile UK male). Eight anthropometric variables were gathered from each participant along with a range of data that allowed the driving posture that they adopt in the cab of a category N<sub>3</sub> vehicle to be recreated, including joint angles, photographs and preferred values for seat height, seat fore-aft adjust, and steering wheel position. These data were then used to posture the DHMs within the DAF occupant accommodation model by a team that have experience in the design and analysis of vehicle occupant accommodation packages in a large number of previous research and consultancy projects.

With the occupant accommodation model and driving population defined, the location of this package within the FKA prototype (See Figure 4) needed to be defined. An analysis of the FKA interior space was performed in order to identify reference points for the placement of the occupant accommodation model. A key requirement of the driver is the ability to effectively use the offside and nearside windows to perform direct vision observations, and so the fore aft location of the occupant accommodation model was determined using the offset of the lowest,



rearmost H-point to the rear vertical edge of the driver's window. In this way the location of the driver's eye point within the aperture of the offside window would be the same as the DAF XF baseline vehicle. In a similar manner, the lateral location of the occupant accommodation model was determined using the offset from the lowest rearmost H-point location to the external panel of the driver's door.



Figure 4. The FKA concept vehicle which takes advantage of additions to vehicle length by adding an aerodynamic nose section in front of the driver

Figure 5 shows the occupant accommodation package located within the FKA concept. The dash board and instrument panel data from the DAF XF 105 was then integrated into the FKA concept to allow the obscuration effects of a standard vehicle interior to be tested in combination with the enlarged windscreen aperture that the FKA concept employs, see Figure 6. The spatial relationship between the occupant accommodation package and the dashboard structure found the DAF XF 105 were maintained.



Figure 5. The occupant accommodation package from the DAF XF 105 placed within the FKA prototype.

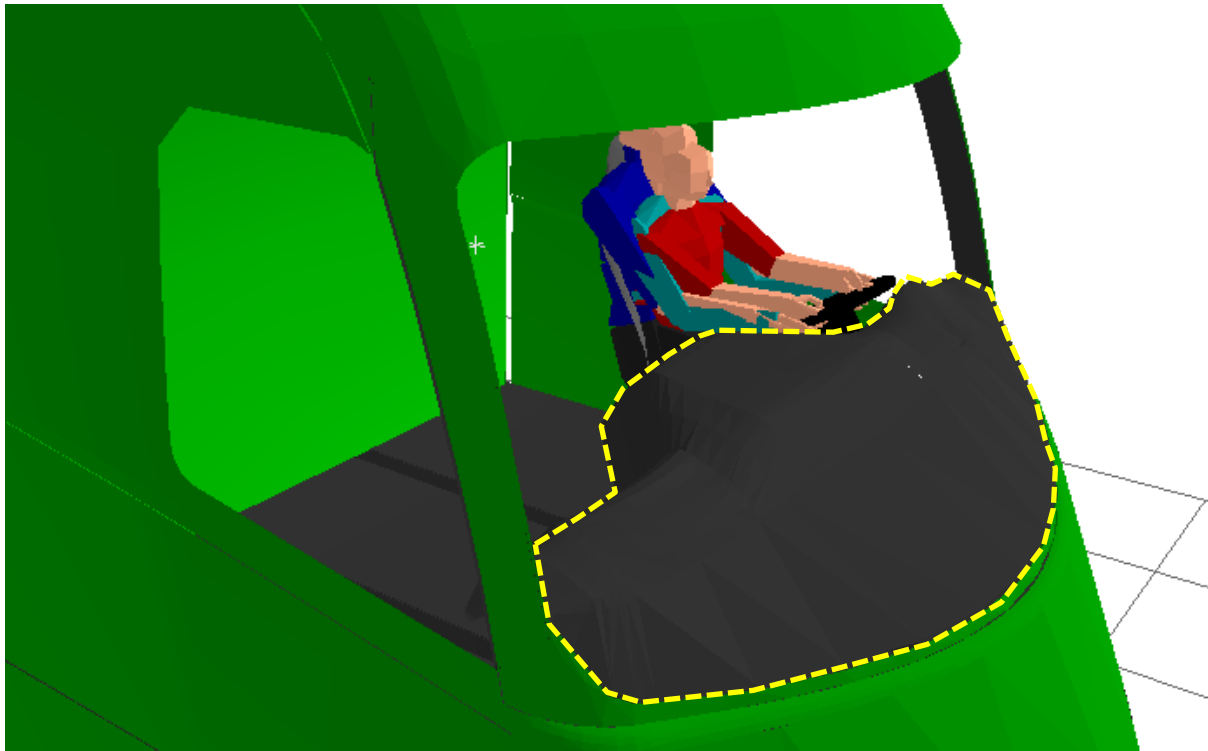

Figure 6. The dashboard and instrument panel structure from the DAF XF integrated in the FKA prototype (highlighted by the yellow dashed line)

### 3.1.3 THE RATIONALE AND DESIGN PROCESS FOR THE CREATION OF CONCEPT VEHICLES BASED UPON THE FKA CONCEPT

The specification for the project included the analysis of the direct vision provided by the FKA concept, followed by the iterative redesign of this concept to allow improved direct vision. An initial analysis of the direct vision provided by the DAF XF 105, and the FKA prototype was performed, and it was determined that the FKA prototype provides superior direct vision, however, it was noted that large blind spots in direct vision still existed beyond the passenger door, and in front of the vehicle. In order to explore options for improving the direct vision to these locations, a strategy was defined in terms of reducing visual obscuration with the following key phases.

- It was noted that the existing dashboard structure that was derived from the DAF XF was limiting the direct vision through the enlarged windscreen of the FKA prototype. Therefore a reduced instrument panel was designed to allow the reduction of the dash board surface.
- With the dashboard obscuration greatly reduced extra window apertures were added to the vehicle structure above the crash protection structures that were defined within the FKA prototype. The design of the structures directly below the windscreens of existing vehicle designs were used to support the definition of the size and location of the extra window apertures. In addition, extra windows were added below the door windows in a manner that replicates recent modifications performed by Laing O'Rourke and Scania. (See Figure 7).



Figure 7. The additional side windows added to Scania Vehicles in collaboration with Laing O'Rourke

The result of this process can be seen in Figure 5 with the first iteration that was used in the project. The second iteration was based upon the reduction in eye height of the driver by lowering the vehicle. This was done by analysing the height variability in existing vehicle designs that is possible through the combination of suspension systems and axel configurations. The specifications for Scania vehicles were analysed and it was determine that a reduction in height of 230mm was possible. These variables have the potential to reduce the off road capability of the vehicle due to reduced ground clearance. The 230mm value was used in the further alteration of the first interaction design by reducing the height of the structure of the vehicle below crash structure associated with the 'pendulum test' (See Section 3.1.4). This allowed the floor of the cab to be lowered. An engine tunnel was placed into the floor of the cab to allow the height of the engine to remain unchanged. The reduced height version of the 1<sup>st</sup> iteration became the third vehicle design that was included in the analysis (see Figure 9). Finally, a more radical approach was taken in the production of the third design iteration. Previous research by the LDS team (Cook et al 2011) highlighted the difficulty in designing mirror systems that allow

direct vision to be supplemented due to the obscuration provided by the cab structure in both left hand drive and right hand drive configurations.

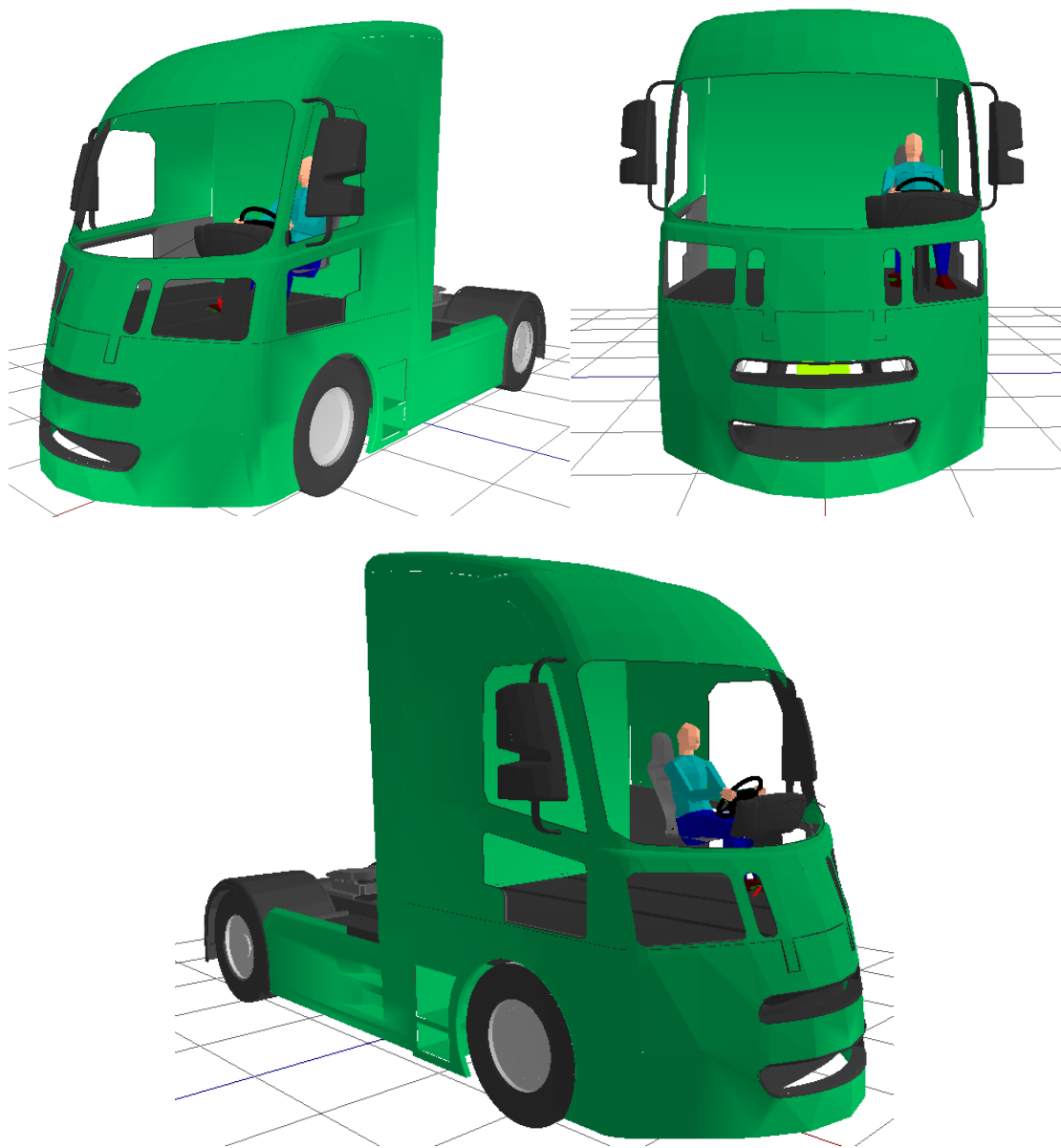

**Figure 8.** The first iteration of the FKA concept to allow improved direct vision by reducing the obscuration of the dash structure and adding window apertures to the vehicle structure

The final concept was therefore designed to explore the potential benefits of a central driving position and narrower vehicle cab with the aim of improving lateral direct vision to vulnerable road users and other vehicles. The third and final iteration of the FKA concept can be seen in Figure 10.

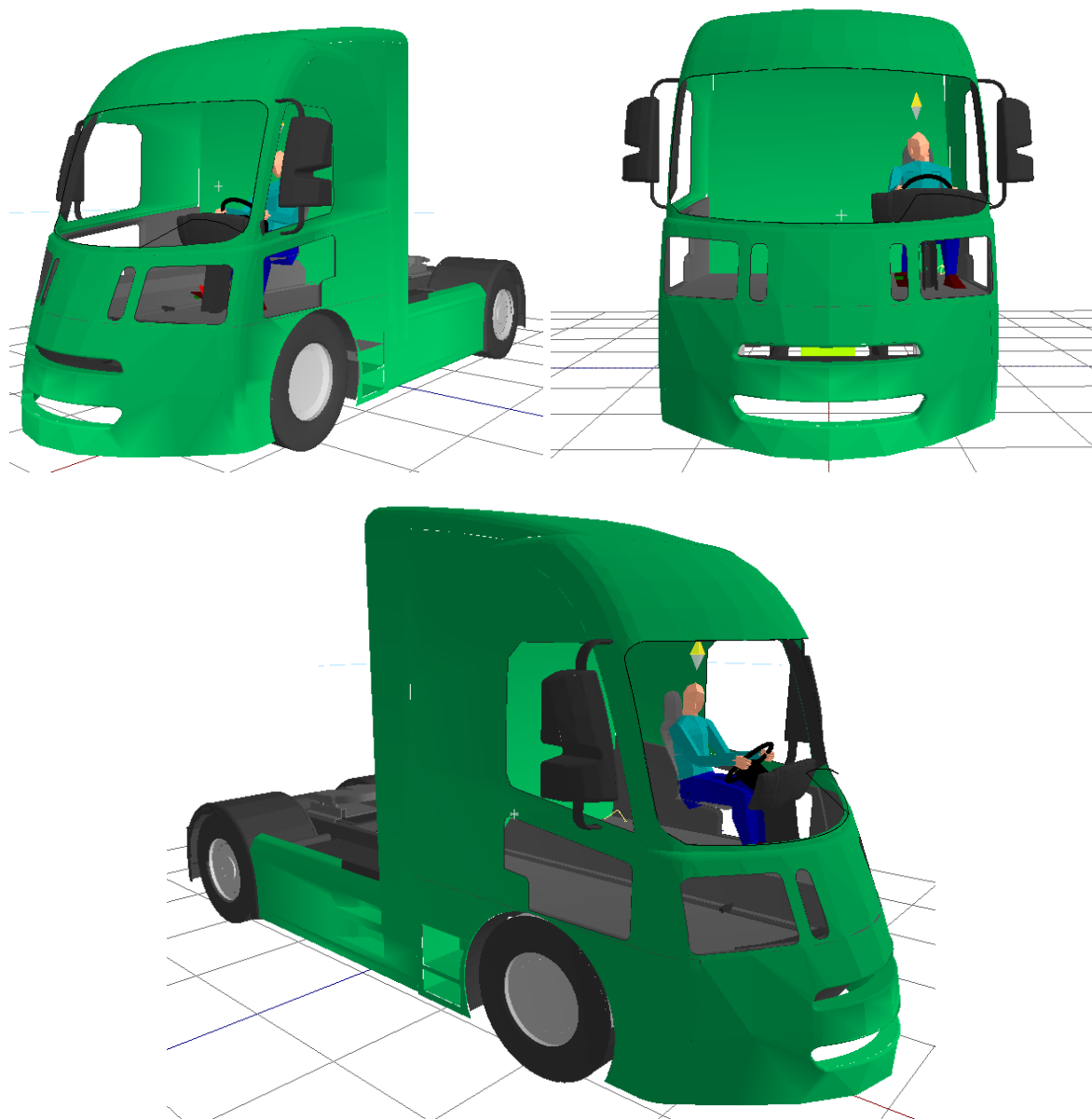

Figure 9. The second iteration of the FKA concept with a driver position that has been lowered by 230mm

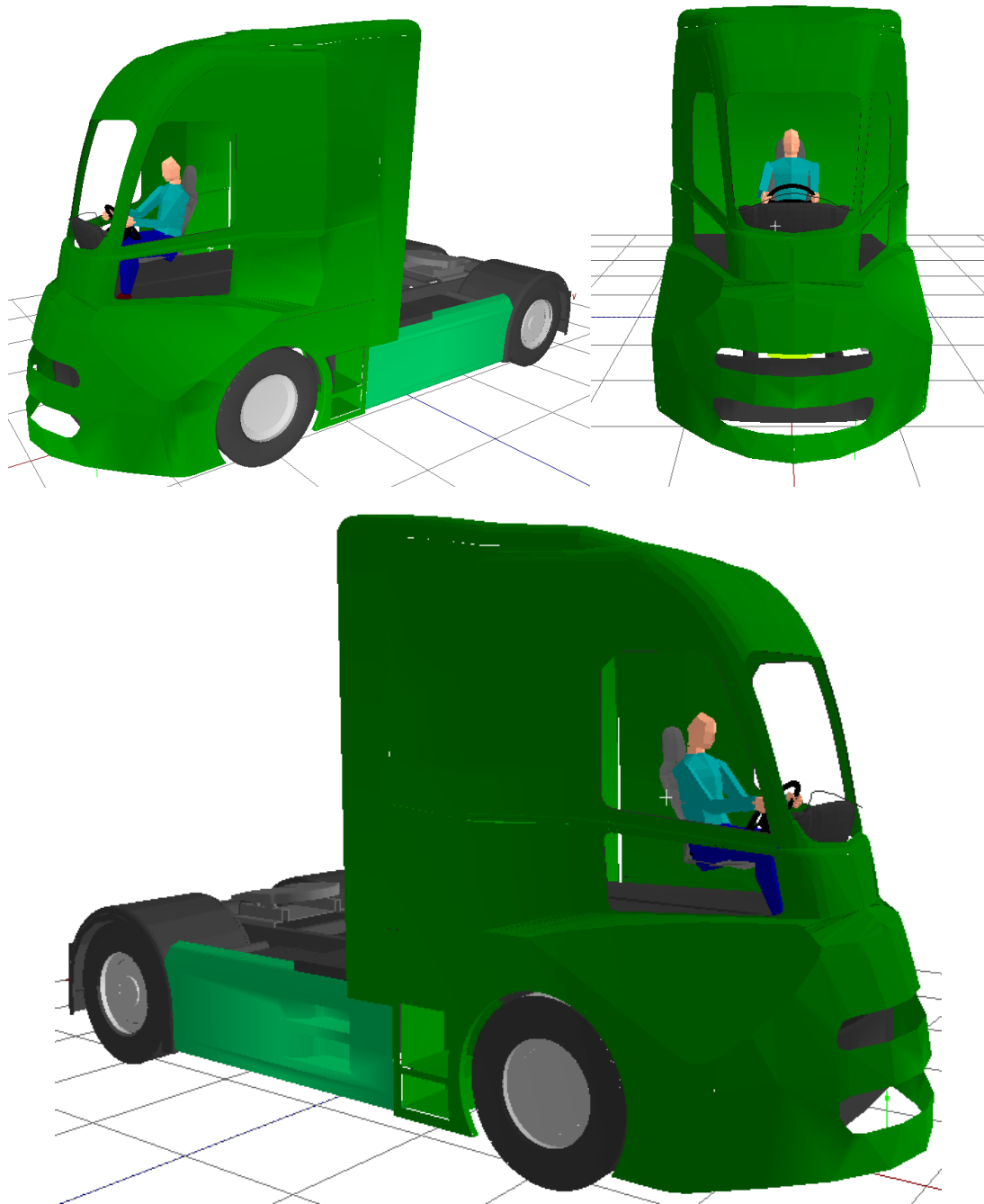

Figure 10. The third iteration of the FKA concept with a central driving position and tapered cab above the line of the crash structure

Therefore the vehicle sample for analysis in this project is as follows;

- The DAF XF 105 as a reference baseline vehicle
- The FKA concept
- The first iteration of the FKA concept with additional glazed areas
- The second iteration of the FKA concept with a lowered cab height and additional glazed areas
- The third iteration of the FKA concept with a central driving position

### 3.1.4 EC STANDARDS AND REGULATIONS AND THEIR IMPACT ON VEHICLE DESIGN

The original FKA prototype model and all of the subsequent modifications made to that design detailed in the previous section have been developed in line with the relevant EC directives and regulations. Of specific relevance to this work are the regulations listed in below.

Regulation	Coverage	Title
595/2009/EC	Emissions	on type-approval of motor vehicles and engines with respect to emissions from heavy duty vehicles (Euro VI)
ECE Regulation 73	Lateral Protection	Uniform provisions concerning the approval of: <ol style="list-style-type: none"> <li>I. Vehicles with regard to their lateral protection devices (LPD)</li> <li>II. Lateral protection devices (LPD)</li> <li>III. Vehicles with regard to the installation of LPD of an approved type according to Part II of this Regulation</li> </ol>
2000/40/EC & ECE Regulation 93	Front Underrun Protection	Uniform provisions concerning the approval of: <ol style="list-style-type: none"> <li>I. Front underrun protective devices (FUPDs)</li> <li>II. Vehicles with regard to the installation of an FUPD of an approved type</li> <li>III. Vehicles with regard to their front underrun protection (FUP)</li> </ol>
ECE Regulation 29	Pendulum Tests	Uniform provisions concerning the approval of vehicles with regard to the protection of the occupants of the cab of a commercial vehicle
92/114/EEC	External Projection of Cabs	relating to the external projections forward of the cab's rear panel of motor vehicles of category N
661/2009/EC	General Safety	concerning type-approval requirements for the general safety of motor vehicles, their trailers and systems, components and separate technical units intended therefore
2003/97/EC, 2005/27/EC & ECE Regulation 46	Indirect Vision	amending, for the purposes of its adaptation to technical progress, Directive 2003/97/EC of the European Parliament and of the Council, concerning the approximation of the laws of the Member States relating to the type-approval of devices for indirect vision and of vehicles equipped with these devices
97/27/EC, 2003/19/EC & 96/53/EC	Masses and Dimensions	amending, for the purposes of adapting to technical progress, Directive 97/27/EC of the European Parliament and of the Council relating to the masses and dimensions of certain categories of motor vehicles and their trailers

Table 6. Relevant EC Directives and Regulations, Applicable to Category N<sub>3</sub> Vehicles.

The original FKA prototype has been designed to ensure compliance with all of the identified regulations except for the provisions concerning maximum authorised vehicle length as set out in the current version of 96/53/EC.

Currently the maximum total length of semi-trailer trucks is 16.5 m. The target is to allow for sufficient productivity of vehicle combinations and to improve the driver's space. To this end, the maximum length of a semi-trailer was limited to 13.6 m and the maximum distance between the king pin and frontend of the semi-trailer to 2.04 m.

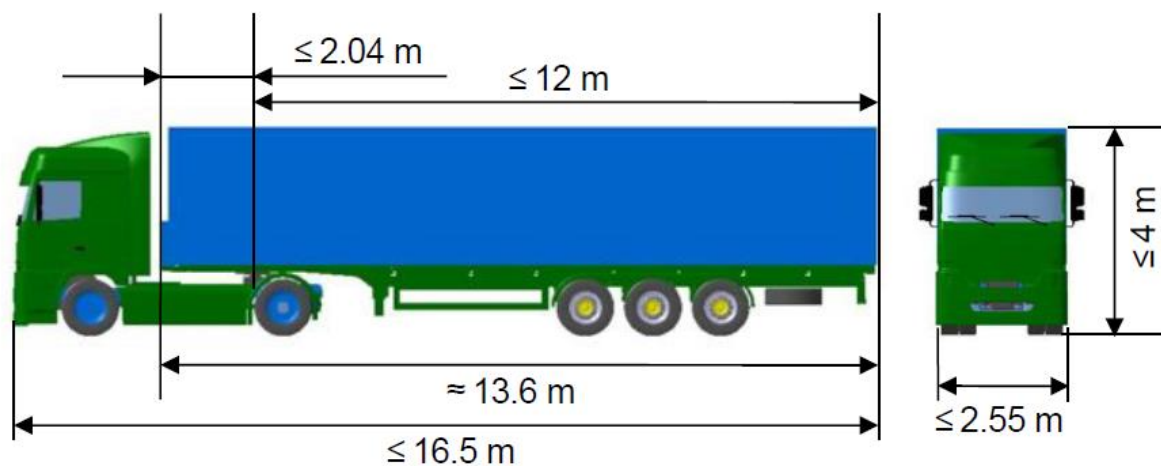

Figure 11. Lengths guideline for European tractor/trailer combinations (96/53/EC) (FKA 104190 2011)<sup>7</sup>

In order to explore the advantages of a design for improved aerodynamic efficiency and potential improvements to direct vision, FKA explored the opportunity to modify the vehicle length restrictions by allowing the tractor unit to be extended. The tractor unit design used for the evaluations documented in this report exhibits an increased length of 800mm with an additional wheel base of 400mm.

For all other regulated performance criteria the FKA prototype has been evaluated and shown to meet or exceed requirements, including manoeuvrability (97/27EC), external projections (92/144/EEC), lateral protection (89/297/EEC and EC Regulation 73).

The FKA cab has also been designed to meet the necessary pendulum tests as defined in EC Regulation 23. Whilst not explicitly modelled, it is expected that the pendulum tests would be passed by this concept due to the additional crush zone provision at the front of the cab. Regarding roof strength and rear wall strength tests, the general structure of the cap is retained over traditional designs and as such there is no reduction in performance over existing vehicles. Though the

<sup>7</sup> Design of a Tractor for Optimised Safety and Fuel Consumption. FKA Report 104,190, August 2011.



pendulum tests were not modelled, the FKA prototype was put through a number of advanced structural simulations for crash performance.

The key principal to the crash protection afforded by the new concept is the additional crash management system. This system utilises extruded aluminium bumpers and crash boxes due to their ability to absorb more energy per unit weight over steel systems and their widespread use within the passenger car industry.

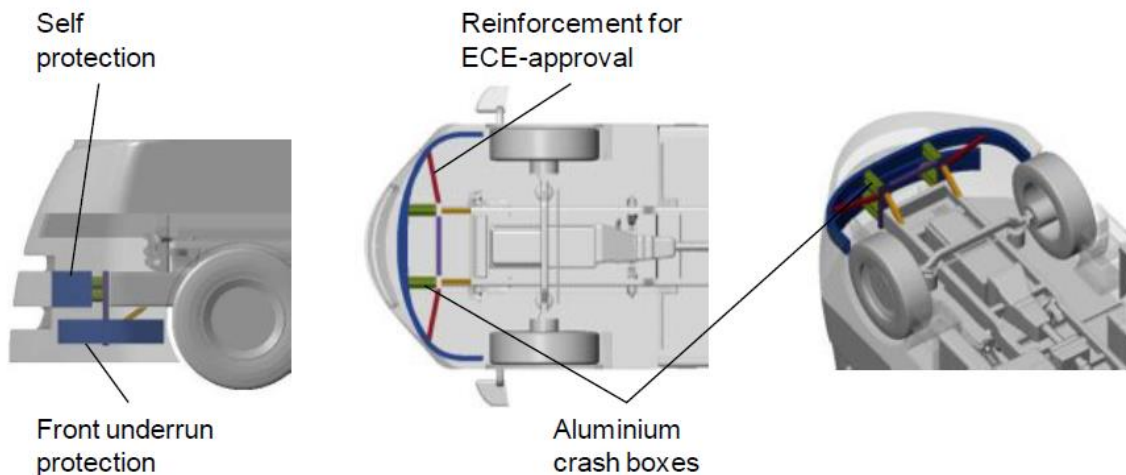

Figure 12. Aluminium Crash Management system in the FKA Prototype (FKA 104190 2011)

The crash performance of the prototype was then modelled for various scenarios derived from accident statistics. These scenarios include front impacts with passenger cars, VRUs and a so called 'self protection' test that involves the cab impacting a semi-trailer.

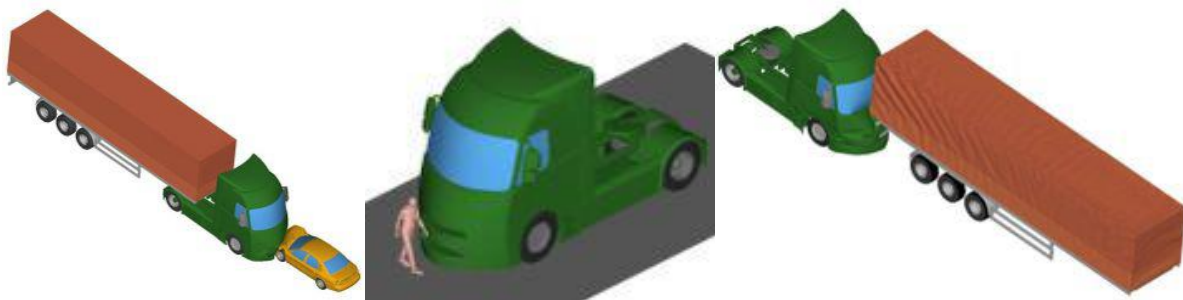

Figure 13. Crash Simulation Scenarios involving the FKA Prototype (FKA 104190 2011)

In each instance the performance of the FKA prototype was shown to offer advantages particularly in the area of accidents involving VRUs. Due to the curved frontal area of the FKA prototype, pedestrians are typically thrown clear with no chance of overrun.

Of particular importance in the FKA prototype and the further iterations is the use of structural designs related to those seen in vehicle designs in use in vehicles currently on European roads. The lower section of the prototype is consistent across all three designs evaluated and includes the crash management system as shown in

Figure 12. The area above, that includes the main passenger cabin, consists of a front lateral beam between the floor of the cab and lower edge of the windscreen (see Figure 14).

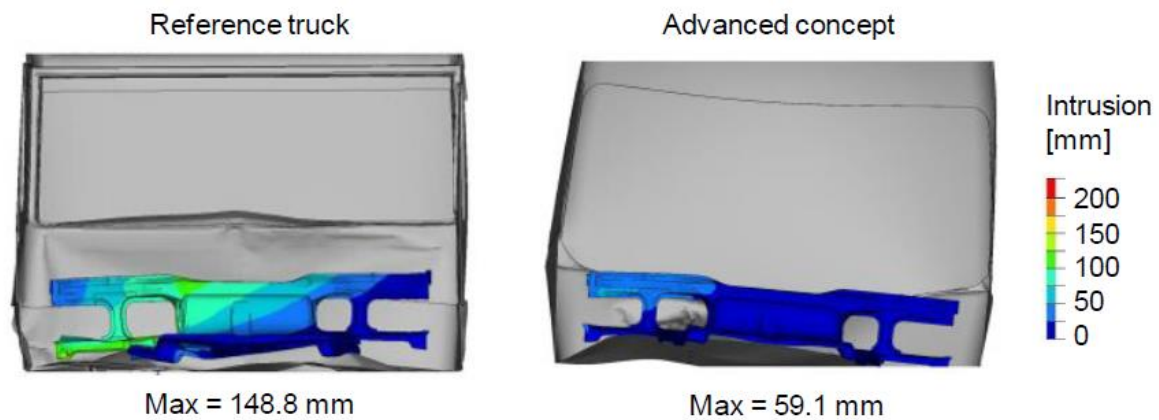

Figure 14. Crash Simulation of the Intrusion into the Front Lateral Beam During the Self Protection Scenario (Reference Truck = standardised vehicle representative of those on the road; Advanced Concept = FKA Prototype) (FKA 104190 2011)

This lateral beam design can be seen on Category N<sub>3</sub> vehicles on the road today such as the Scania model P shown below (Figure 15). The member design can vary but the basic principle of a lateral member with removed sections (see the yellow dashed lines in Figure 15 for section of the member that have been removed to allow electronic connections to pass through) remains consistent. It is this design concept that has been exploited in the iterations of the FKA concept to utilise the beam cut-outs as window areas to improve direct vision. Furthermore it can be seen that this area is currently heavily utilised by truck manufacturers for the location and routing of various vehicle systems. Thus the inclusion of this structure allows some of these systems to still be located in this area although manufacturers would need to ensure the glazed areas are kept free of obscuration.



Figure 15. Scania Model P Front Structure.

### 3.1.5 APERTURE PROJECTIONS AND BLIND SPOT ANALYSIS

The methodology for the analyses performed was developed to evaluate the visible areas adjacent to the test vehicles i.e. can something that should be seen by the driver using direct vision through the windows, be hidden from driver in a blind spot. This involves the projections of the visible volume of space from the eye point of the driver through the apertures (windows) of the vehicles. Anything that is inside the projections can be seen directly by the driver. Figure 16 shows an example where the driver of the HGV is looking through the passenger window. The head and shoulders of the cyclist can be seen by the driver, as illustrated by the head and shoulders being inside the window aperture projection. This projection technique is a feature of the SAMMIE Digital Human Modelling system that is developed at the Loughborough Design School in the UK.



Figure 16. An illustration of the aperture projection technique used in the SAMMIE DHM system. The green semi-transparent volume represents the volume of space visible to the driver through the passenger window.

Multiple window projections can be combined to allow the visualisation of what can and cannot be seen by the driver through windows. These analyses are essentially three dimensional and often provide illustrations of complex fields of view (FOV). See Marshall et al (2013)<sup>8</sup>. The FOVs produced are communicated using 3D images of the interaction of the volumetric projections and a visual target. A total of three visual targets are utilised:

- i. A 50<sup>th</sup> %ile UK male (stature 1755mm, equivalent to 63%ile German male, 72%ile French male, 26<sup>th</sup> %ile Dutch male) used to represent a pedestrian.
- ii. A 50<sup>th</sup> %ile UK male riding a standard sized adult mountain bike used to represent a cyclist.
- iii. A 2010 model Volkswagen Golf used to represent a common Category M<sub>1</sub> vehicle.

In addition to 3D projections, 2D visual areas representing the intersection of the projected volume and a 2D plane, such as the ground are also assessed. This 2D approach is a simplification of the FOV afforded to the driver but can be used to provide an overview of visibility at a critical height above the floor. In addition this approach is used to define the necessary areas of visibility on the ground for indirect vision (through mirrors) in UNECE Regulation 46 and thus is a familiar methodological approach in FOV modelling. In the analyses four 2D plane heights are used:

- i. Ground plane. This is used as a standardised projection to provide an overview of direct vision baseline for all test vehicles.
- ii. Ground plane + 1450mm. This is used to represent the FOV at a height coincident with the top of the Golf visual target.
- iii. Ground plane + 1738mm. This is used to represent the FOV at a height coincident with the top of the cyclist visual target.
- iv. Ground plane + 1755mm. This is used to represent the FOV at a height coincident with the top of the pedestrian visual target.

Informed by the STATS19 accident data analysis described earlier, a number of analysis configurations were identified for evaluation:

- i. Forward Visibility
  - a. The visibility of a pedestrian(s) across the front of the assessment vehicle. Three pedestrian targets are positioned in line with the centre line of the vehicle and at each of the outer edges. This is designed to represent a pedestrian crossing in front of the test vehicle.

---

<sup>8</sup> Development of a volumetric projection technique for the digital evaluation of field of view. Russell Marshall, Stephen Summerskill, Sharon Cook. Ergonomics. Vol. 56, Iss. 9, 2013

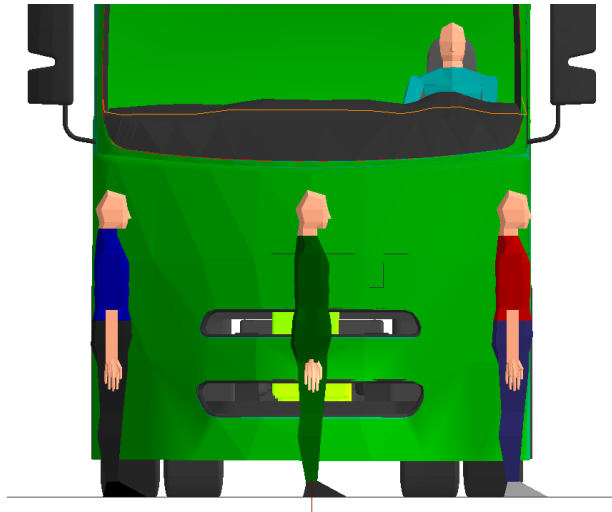

Figure 17. The configuration of the pedestrian visual targets positioned in front of the vehicle

- b. The visibility of a cyclist(s) across the front of the assessment vehicle. Three cyclist targets are positioned in line with the centre line of the vehicle and at each of the outer edges. This is designed to represent a cyclist positioned at any point in front of the test vehicle, waiting at an advanced stopping area at a junction.

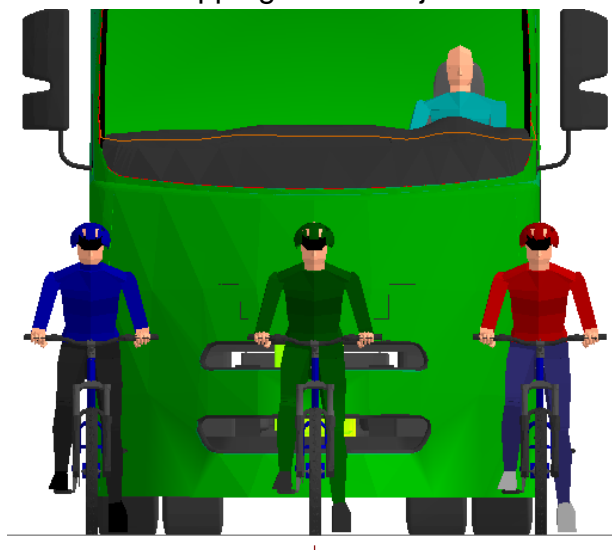

Figure 18. The configuration of the cyclist visual targets positioned in front of the vehicle

ii. Offside (driver side) Visibility

- a. The visibility of a cyclist(s) along the driver's side of the vehicle. The first cyclist is positioned fore-aft to align the top of their head with the driver's eye-point, the second cyclist is 1m in front of the first. This is designed to represent a cyclist overtaking the test vehicle. The visual targets are positioned in these locations to represent the primary locations for direct vision to the side of the vehicle. Rearwards of these locations is not a priority for direct vision, and forward of these locations moves into forwards visibility.



Figure 19. The configuration of the cyclist visual targets positioned to the offside of the vehicle

- b. The visibility of a car to the driver's side of the vehicle. The car is positioned such that its mirrors are aligned with the mirrors of the test vehicle. This is designed to represent a car overtaking the test vehicle. The visual target is positioned in this location to represent the primary location for direct vision to the side of the vehicle. Rearwards of this location is not a priority for direct vision, and forward of this location moves into forwards visibility.



Figure 20. The configuration of the car visual target positioned to the offside of the vehicle

- iii. Nearside (passenger side) Visibility
  - a. The visibility of a cyclist(s) along the passenger's side of the vehicle. The cyclist is positioned fore-aft to align the top of their head with the driver's eye-point, (where used, a second cyclist is 1m in front of the first). This is designed to represent a cyclist either riding or waiting to the inside (nearest the pavement) of the vehicle.
  - b. The visibility of a car to the passenger's side of the vehicle. The car is positioned such that its mirrors are aligned with the mirrors of the test

vehicle. This is designed to represent a car proceeding along in the inside lane adjacent to the test vehicle.

For all of the analysis configurations the analysis will attempt to position the visual target at a point at which they are just *not* visible to the driver. This will highlight the limits of visibility of the driver of the targets around the vehicle. This method has been selected to avoid the ambiguity of defining how much of a target should be visible to the driver.

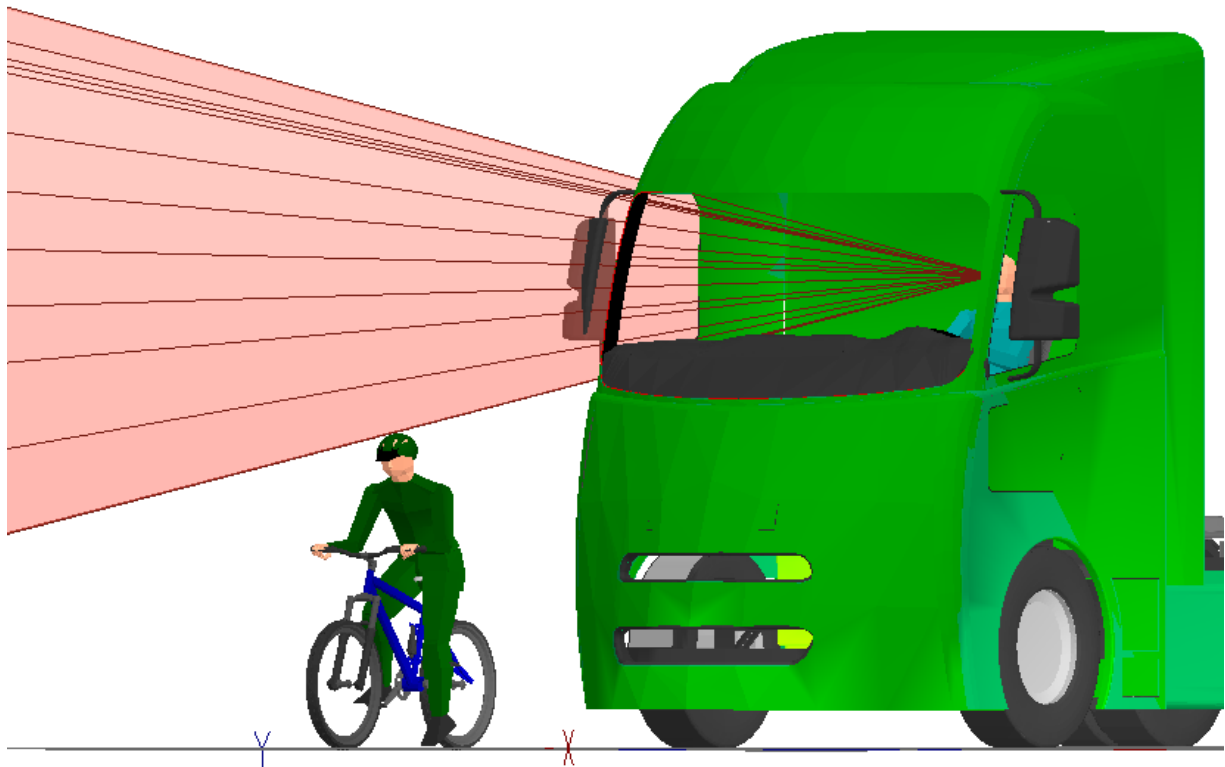

Figure 21. Positioning of visual target at a point where the target is just not visible (against the projected volume).

Figure 21 shows a cyclist visual target to the nearside (passenger side) of the test vehicle. The cyclist has been moved laterally away from the side of the vehicle until the helmet of the cyclist is at a point where it just fails to intersect with the projected visible volume from the passenger window. This represents the furthest the cyclist could be away from the vehicle and still not be visible. By positioning the visual target in this way the size of any blind spot is illustrated.

Where visual targets are not visible to the driver, the shortest distance between the target and the test vehicle is measured (Figure 22). This provides objective measures for the comparison of direct vision between test vehicles.

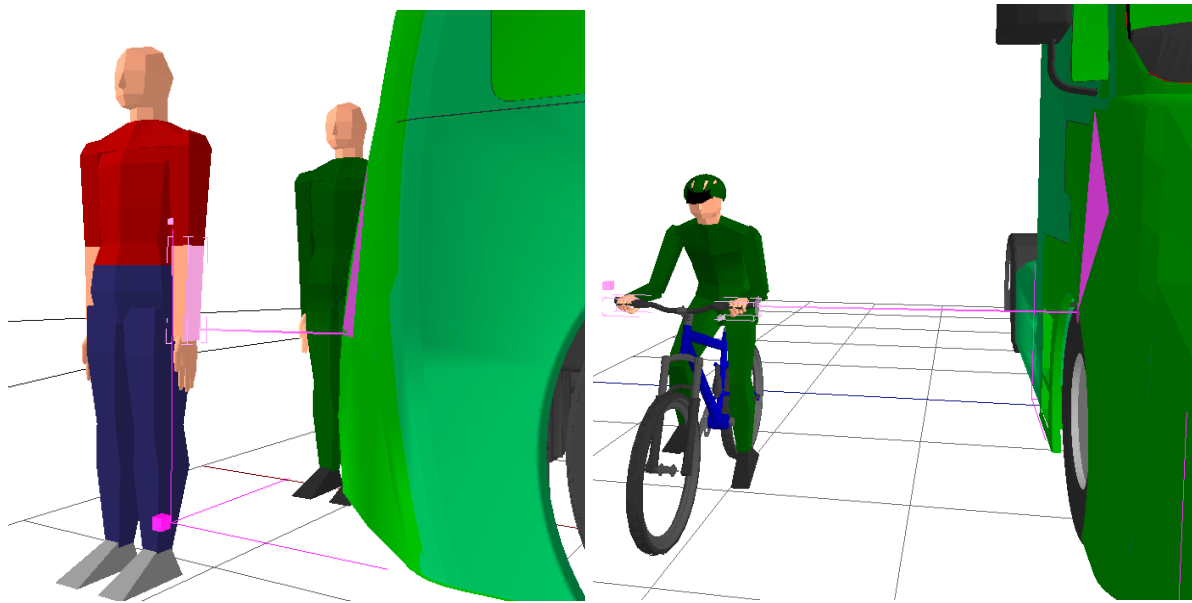

Figure 22. Measurement of shortest distance of a non-visible target to the test vehicle

For visual targets that are always visible regardless of positioning, illustrations will still be provided to provide an understanding of the degree of visibility. This will include images taken from the driver's eye point giving an indication of what the driver would actually be able to see (Figure 23).

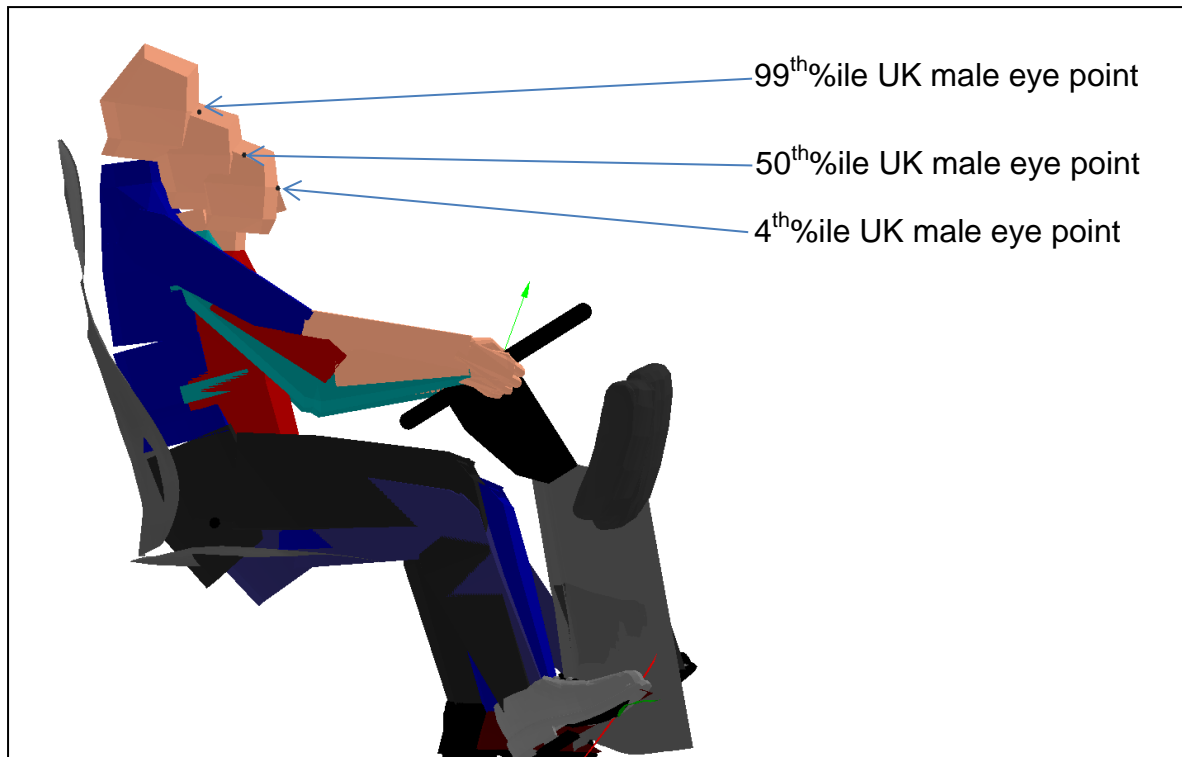

Figure 23. Driver's view of the visual targets adjacent to the vehicle

An aspect that must be clearly understood in the analysis of blind spots is the variability in potential driver eye position due to variable driver size. As discussed in section 3.1.2 three digital human models have been defined for analysis that represent small, medium sized and large drivers. The smallest digital human model



(4<sup>th</sup>ile UK male driver stature) has an eye point that is lowest above the vehicle floor, and closest to the front of the vehicle. The largest digital human model (99<sup>th</sup>ile UK male stature) has an eye point that is highest above the vehicle floor and furthest from the front of the vehicle as shown in Figure 24.



**Figure 24. The variability in eye point that is defined by a range of driver sizes based upon observed posture for those driver sizes**

The variability in driver's eye location due to the variability in driver size is usually represented in the vehicle design and assessment process using the Society of Automotive Engineers (SAE) Eyellipse (a contraction of eye and ellipse) data. These Eyellipses are produced by capturing the eye position from a large sample of drivers in specifically designed experiments as described by Reed, 2005<sup>9</sup>. However, as also described by Reed, 2005<sup>8</sup>, the current SAE Eyellipse data (SAE J941) is not applicable to modern goods vehicle designs as the data does not account for height adjustable seats. The three eye positions shown above were therefore defined by postures and body size data captured from truck drivers in previous research performed by the LDS team, and validated using an Eyellipse that was generated using techniques reported in Reed, 2005<sup>8</sup> that are based upon driver posture and eye point data gathered from 63 participants in seats that were height adjustable.

The results shown in section 3.2 predominantly illustrate the blind analysis described in the section above using the average stature UK male digital human model for

<sup>9</sup> Reed, M. P., 2005, "Development of a New Eyellipse and Seating Accommodation Model for Trucks and Buses," University of Michigan Transportation Research Institute, Ann Arbor, MI, Tech. Report No. UMTRI-2005-30.

ease of comparison between vehicles. However, the differences between the blind spot sizes caused by the variability in driver stature are an issue that warrants exploration.

Figure 25 shows the projection through the passenger window of the FKA prototype for the small UK male (top image) and the large UK male (bottom image). The figure shows that the lower eye point of the smaller driver results in the closest point on the floor that is visible to the driver being 10.5m away from the side of the truck. The higher eye point of the taller driver allows this distance to be reduced to 8.7m. Therefore the blind spot size is larger for the smaller driver than it is for the taller driver.

In order to show the differences in blind spot size between each of the vehicle concepts in terms of the variability in driver eye height, illustrations have been produced to show how the window aperture projections intersect with the floor for each eye height. The projection on the floor has been used for two reasons.

1. A plan view of the manner in which projections intersect with the floor is a clear and simple way to compare between vehicles
2. The standards that present field of view information generally present requirements using plan view ground plane plots.

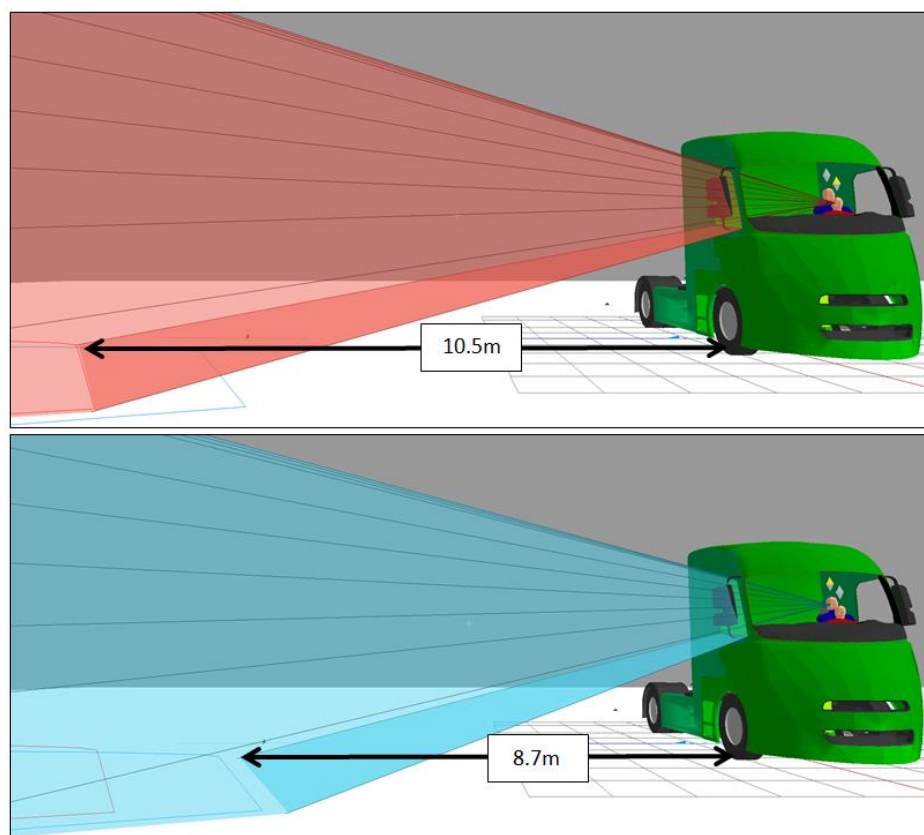

Figure 25. The distance from the side of the vehicle of the closest location on the floor that is visible to the driver through the passenger window for two different sized drivers.

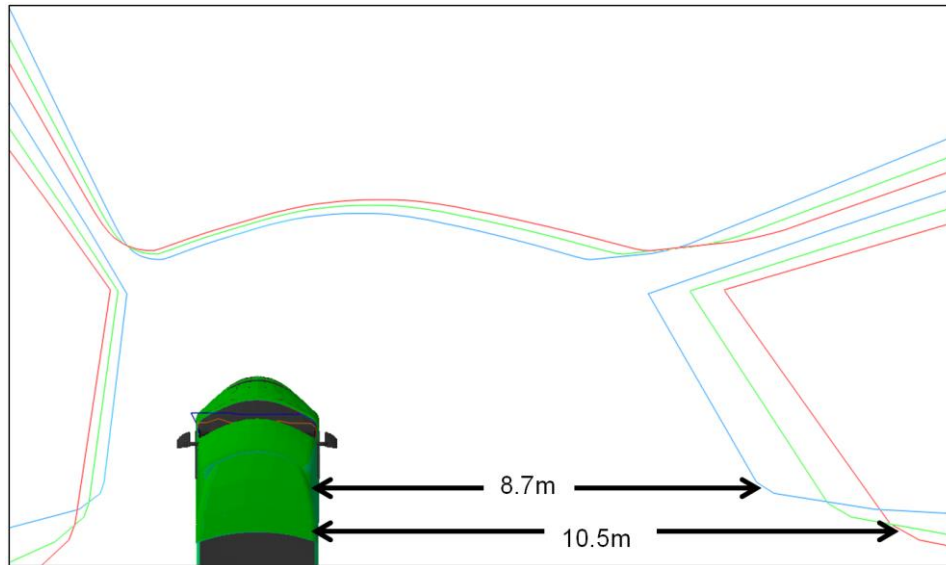

Figure 26. A plan view of the projection of the windscreen and side windows onto the floor.  
Red=smallest driver, Green=average sized driver, and Blue=tallest driver

Figure 26 shows an example of the output where the coloured lines define the intersection of the projections for the windscreen and side windows with the ground plane for the FKA concept. The blue lines show the projections for the tall UK male driver (99<sup>th</sup>ile stature), the green lines show the projections for the average sized UK male driver (50<sup>th</sup>ile stature) and the red lines show the projections for the smallest UK male driver (4<sup>th</sup>ile stature). If Figure 25 and Figure 26 are compared it can be seen how the distance at which the window projections intersect with the floor, can be presented using the plan view two dimensional method.

## 3.2 RESULTS

The following sections describe the results of the analysis as described in Section 3.1.5 for the DAF XF 105, acting as a baseline vehicle, the FKA concept vehicle with an integrated DAF XF occupant accommodation package and dash board structure, the first iteration of the FKA concept vehicle with a reduced dash board structure and additional window apertures, a reduced height version of the second iteration, and a final iteration with a central driving position and tapered cab structure.

### 3.2.1 DAF XF

The following sections show the evaluation of the DAF XF 105 baseline vehicle.

#### 3.2.1.1 DIRECT VISION – APERTURE PROJECTIONS

The following projections illustrate the extent of direct vision afforded to the driver via windows or other apertures in the cab. Figure 27 shows a top-down view of all of the window projections for the DAF XF cab. The image on the right of Figure 27 shows the areas of these projections that intersect with the ground.

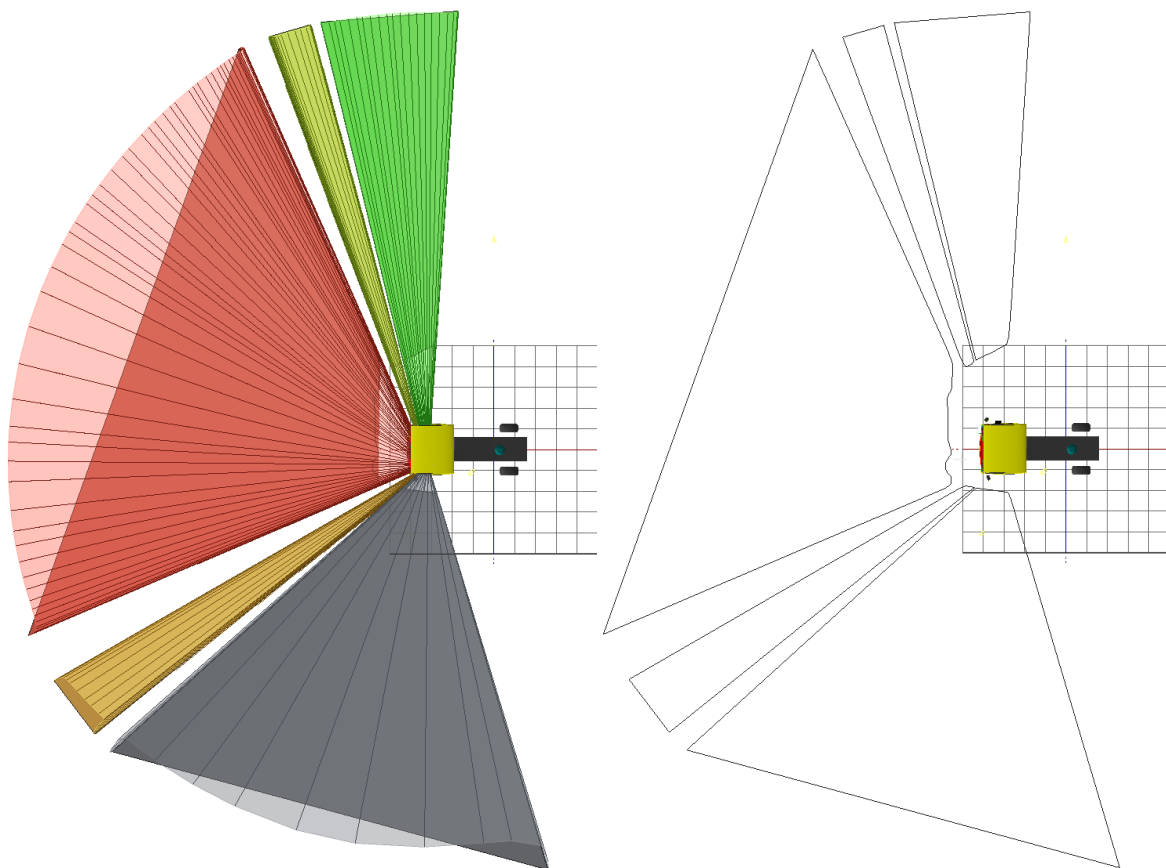

Figure 27. The projection of the windscreen and window apertures at the ground place for the DAF XF 105

Figure 28, Figure 29 and Figure 30 illustrate that the projections are conical in shape, projecting from the driver's eye point through the window aperture and beyond. Due to this conical nature some areas close to the vehicle are not visible. Anything inside the conical projection would be visible to the driver, anything not inside the projection would not be visible without the driver moving or through indirect vision such as a mirror.

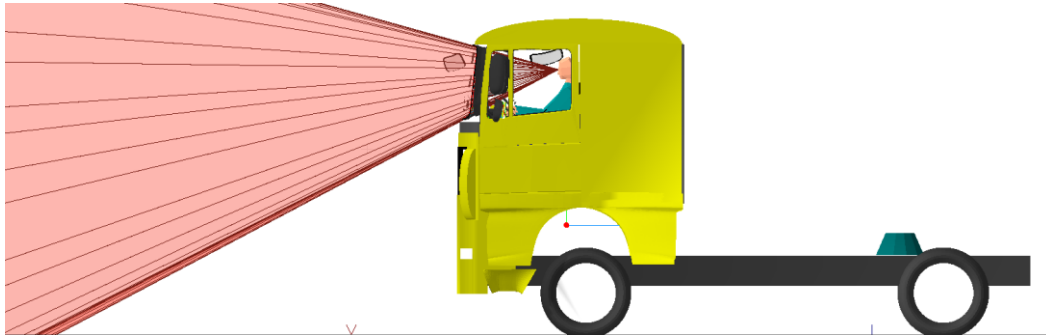

Figure 28. A side view of the wind screen aperture projection for the DAX XF 105.

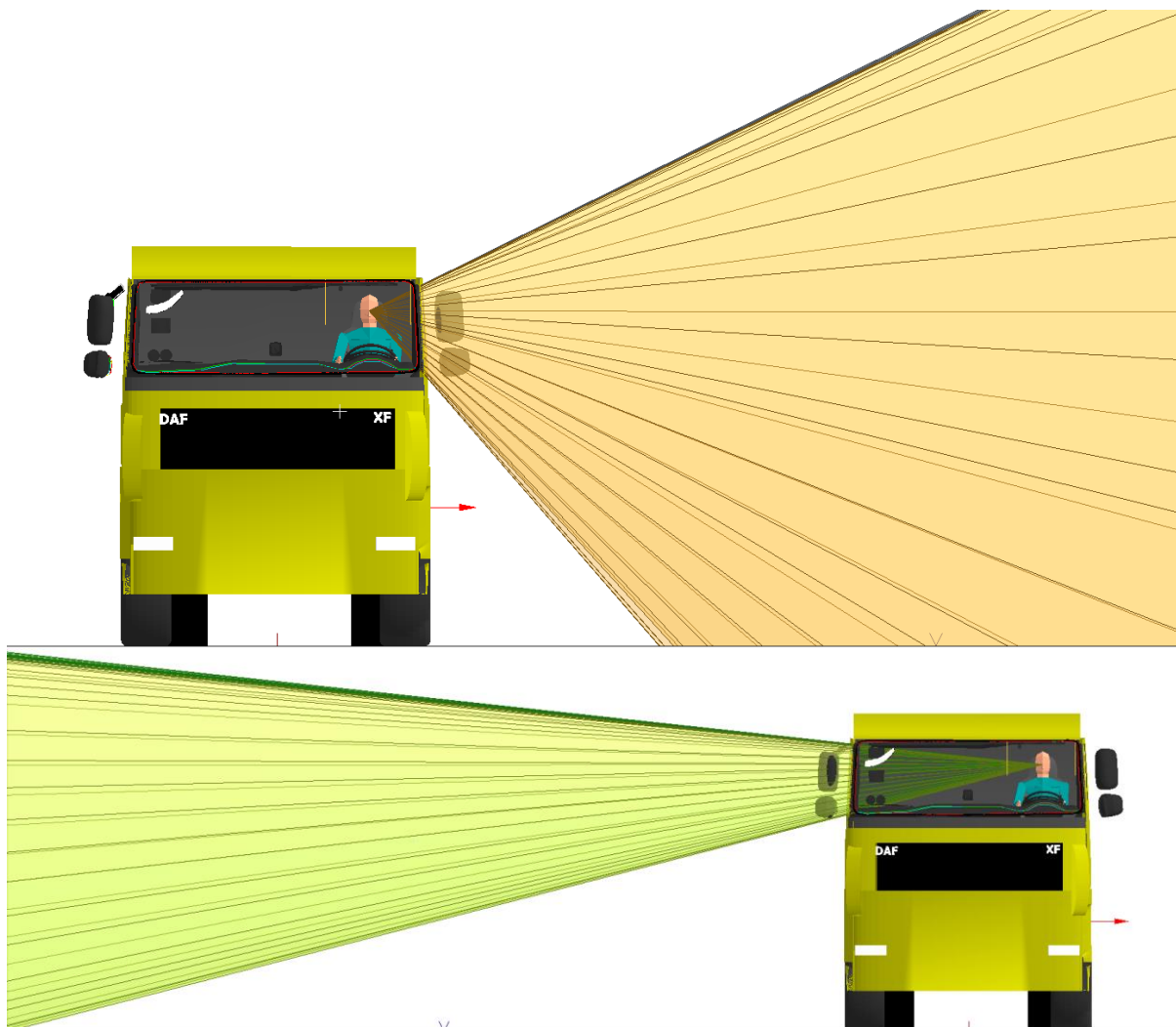

Figure 29. Frontal views of the near side and off side door window projections

### 3.2.1.2 FORWARD VISIBILITY – PEDESTRIAN

Figure 30 shows the visible areas in proximity to the cab taken at a height equivalent to the stature of a 50<sup>th</sup> %ile UK male (1755mm). The intersection of the projection through the windscreen and this plane is shaded green. The uneven edge closest to the vehicle is due to obscuration from the dashboard of the vehicle that occludes the lower edge of the windscreen.

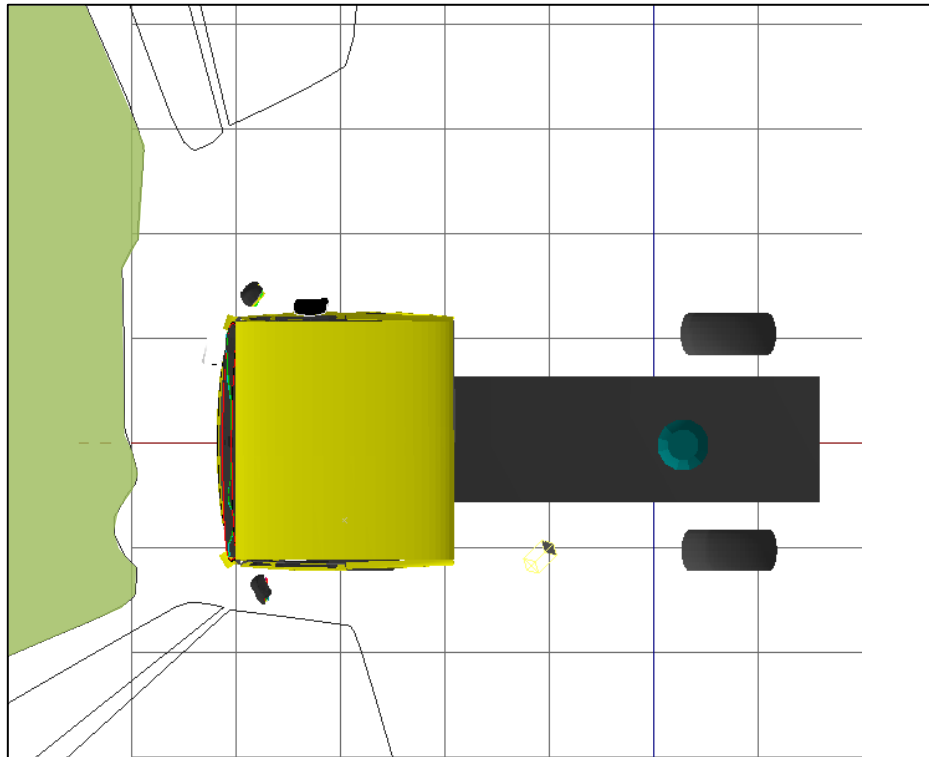

Figure 30. The green area shows the projection of the wind screen aperture at a height above the ground that equals the stature of the 50<sup>th</sup> %ile UK male visual target

From the figure it is clear that the visible areas at a height representative of a pedestrian are closer to the vehicle than those taken at ground level shown in Figure 27. However Figure 31 and Figure 32 show that there is a clear space between the front of the vehicle and the near edge of the visible area in which a pedestrian could be hidden.

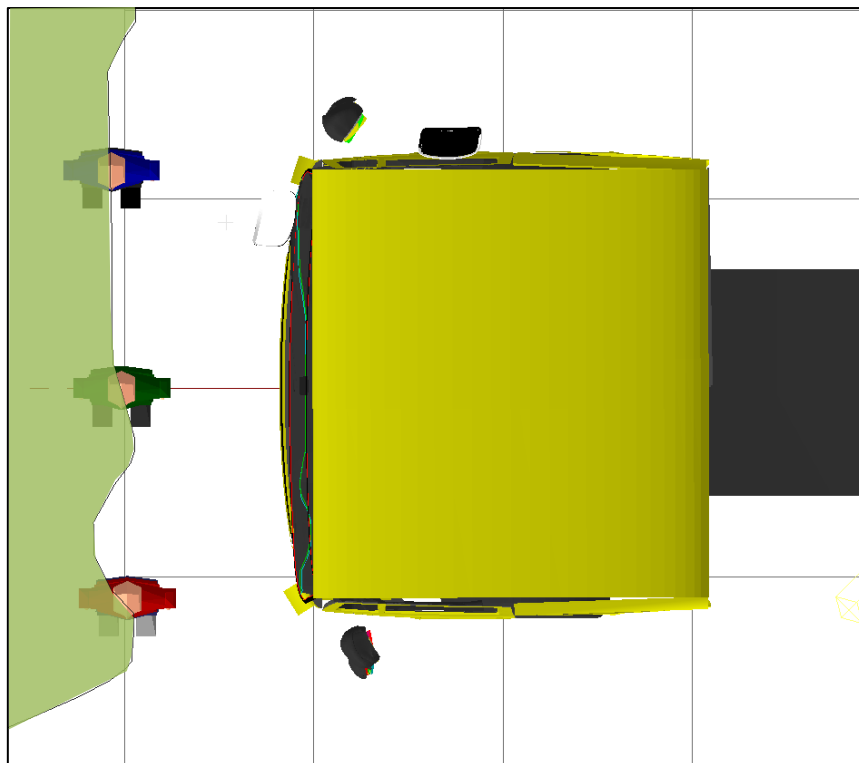

Figure 31. A plan view of the three visual targets human models that represent pedestrians walking in front of a stationary vehicle.

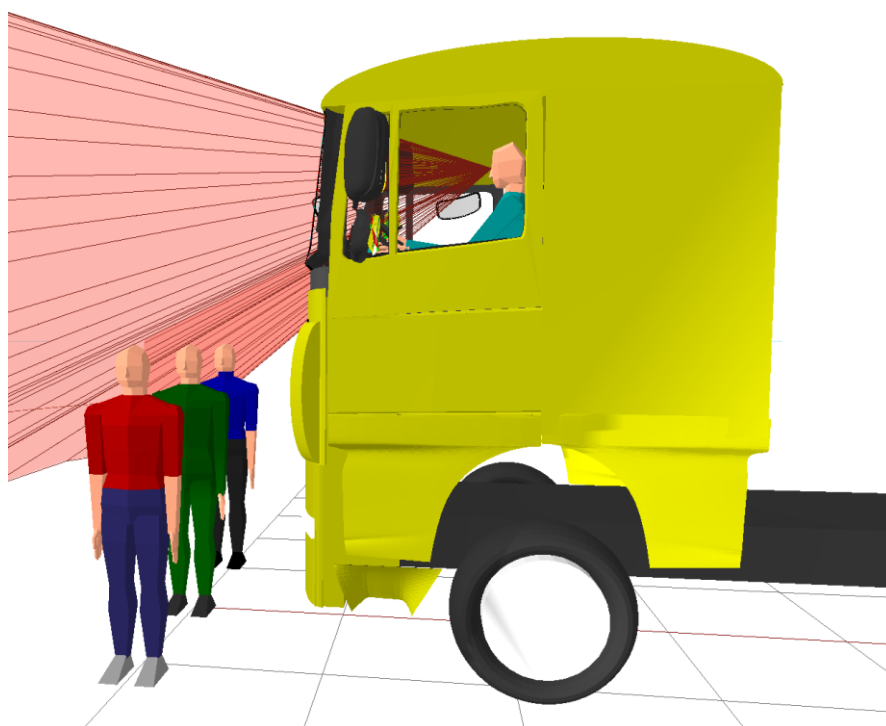

Figure 32. The three visual target human models can stand 690mm (blue), 575mm (green) and 647mm (red) in front of the vehicle without being seen by the driver in the standardised driving posture

For forwards visibility of the pedestrian targets all three pedestrians can be hidden from the driver's view. The right (blue) pedestrian is positioned at 690mm from the

front of the vehicle, the left (red) red pedestrian is positioned at 647mm from the front of the vehicle and the central (green) pedestrian is positioned at 575mm from the front of the vehicle.

### 3.2.1.3 FORWARD VISIBILITY – CYCLIST

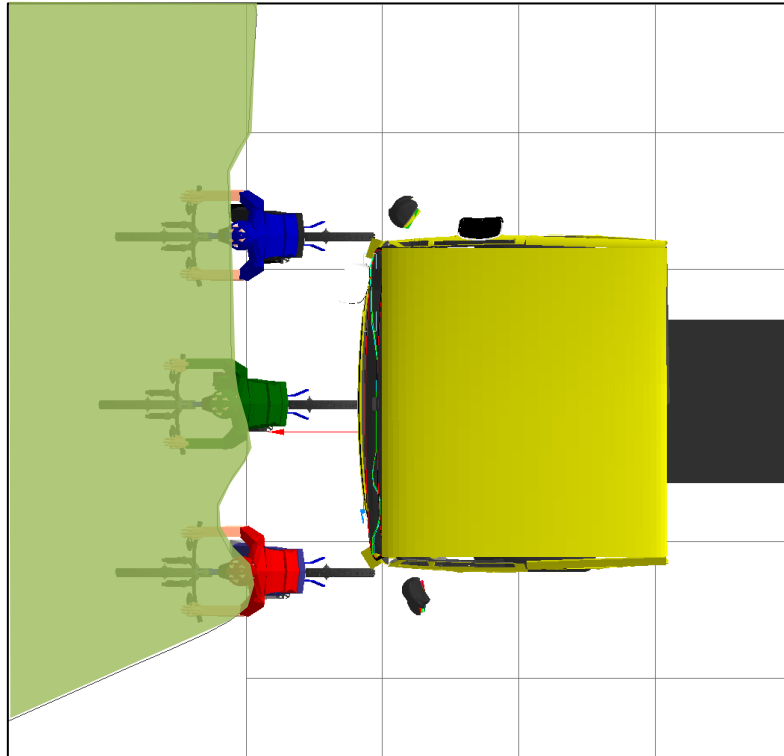

Figure 33. Plan view. The red and green cyclists are directly visible to the driver, but the blue cyclist cannot be seen directly

Figure 33 and Figure 34 show the potential for the cyclist visual target to be hidden from the driver. The three cyclists shown are all essentially touching the front of the vehicle and as shown in Figure 35, only the blue cyclist, to the nearside (passenger side) of the vehicle is completely obscured. Due to the proximity of the cyclists to the vehicle it is unlikely that this situation would occur. Cyclists would position themselves further forward and in doing so would then be visible to the driver.



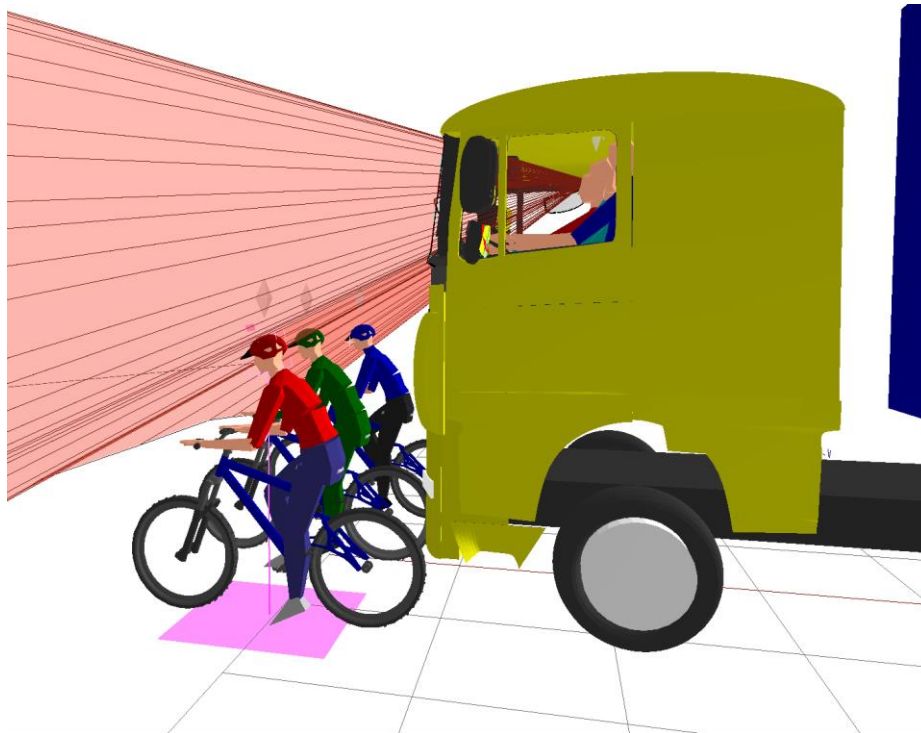

Figure 34. Perspective view. The red and green cyclists are directly visible to the driver, but the blue cyclist cannot be seen directly



Figure 35. Driver's eye view. Small portions of the red and green cyclist helmets can be seen by the driver of the category N3 vehicle.

Small portions of the red and green cyclists' heads are visible to the driver with the cyclist up against the front of the vehicle.

### 3.2.1.4 OFFSIDE (DRIVER SIDE) VISIBILITY – CYCLIST

Visibility to the driver's side of the vehicle, though the side windows is shown in Figure 36 and Figure 37.

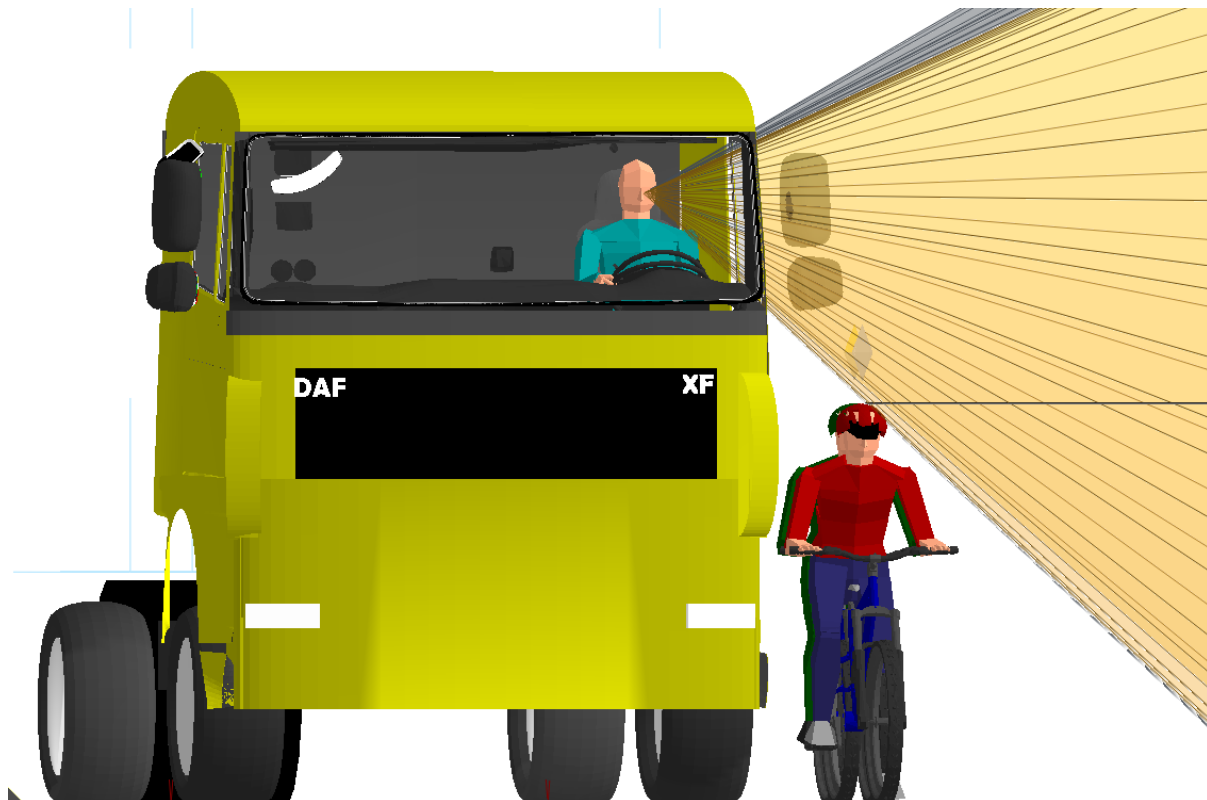

Figure 36. Front view. Cyclists in locations that are close to the side of the driver's door cannot be directly seen by the driver

The projections show that there is a clear blind spot to the driver's side of the vehicle that could obscure a cyclist. The cyclist would need to be very close to the vehicle and this blind spot can be mitigated by the driver leaning and looking down the side of the vehicle. However the driver would need to be aware of this blind spot to perform such a check. Figure 37 shows that the red cyclist is very close to the vehicle, 36mm from the side. The green cyclist can be positioned slightly further away at 106mm from the side of the driver's door and still be hidden.

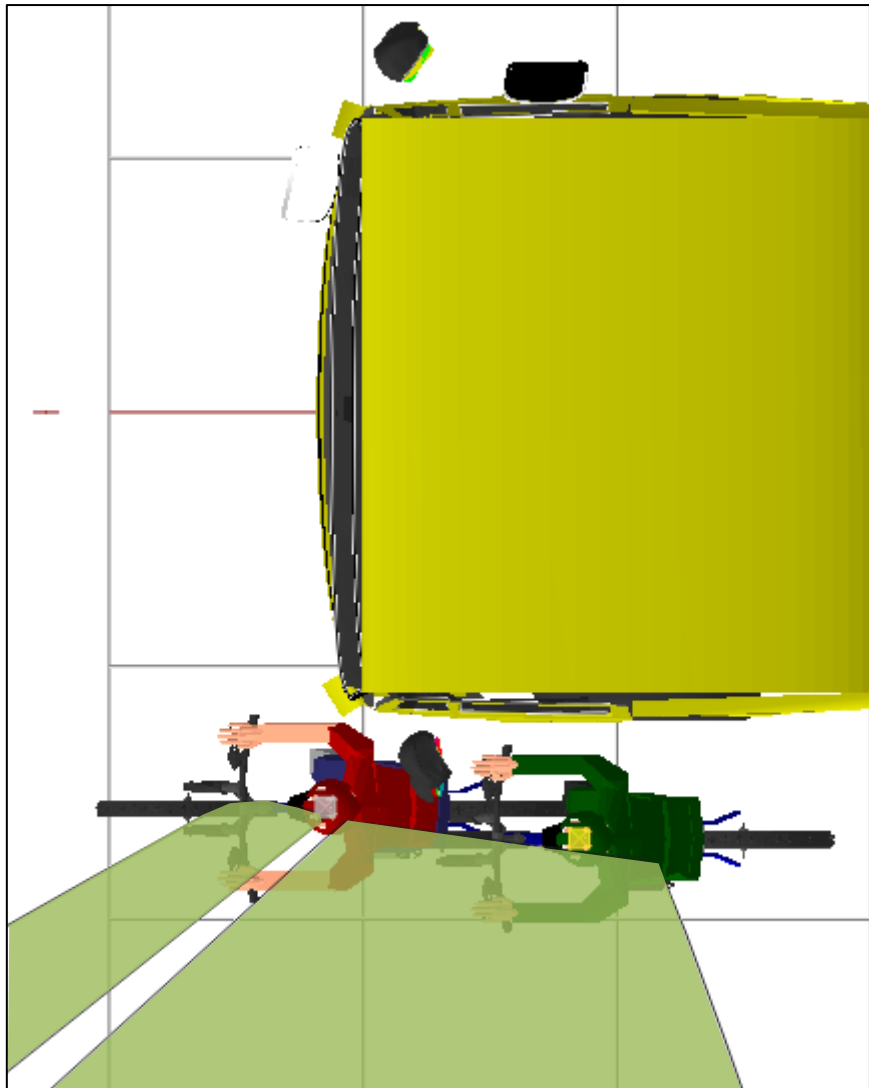

Figure 37. Plan view. Cyclists in locations that are close to the side of the driver's door cannot be directly seen by the driver

### 3.2.1.5 OFFSIDE (DRIVER SIDE) VISIBILITY – VW GOLF

Figure 38 and Figure 39 show the visibility to the driver's side of the vehicle with the Volkswagen Golf visual target. In this instance the car is always visible to driver through the side windows.

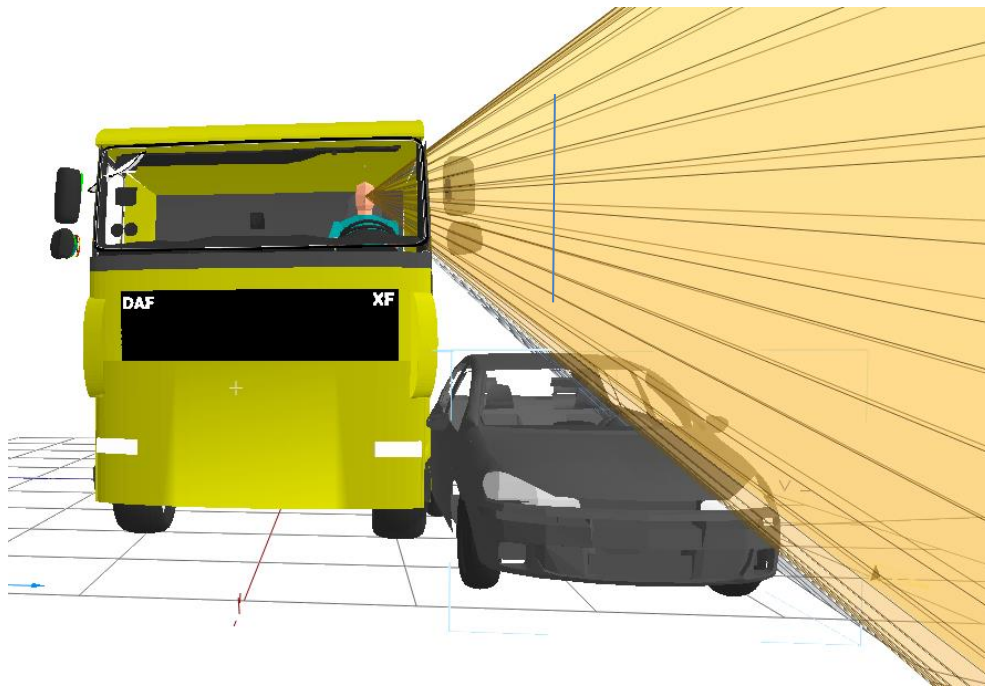

Figure 38. Frontal view. The car can be seen by the Category N<sub>3</sub> vehicle driver when the car is adjacent to the driver's door.

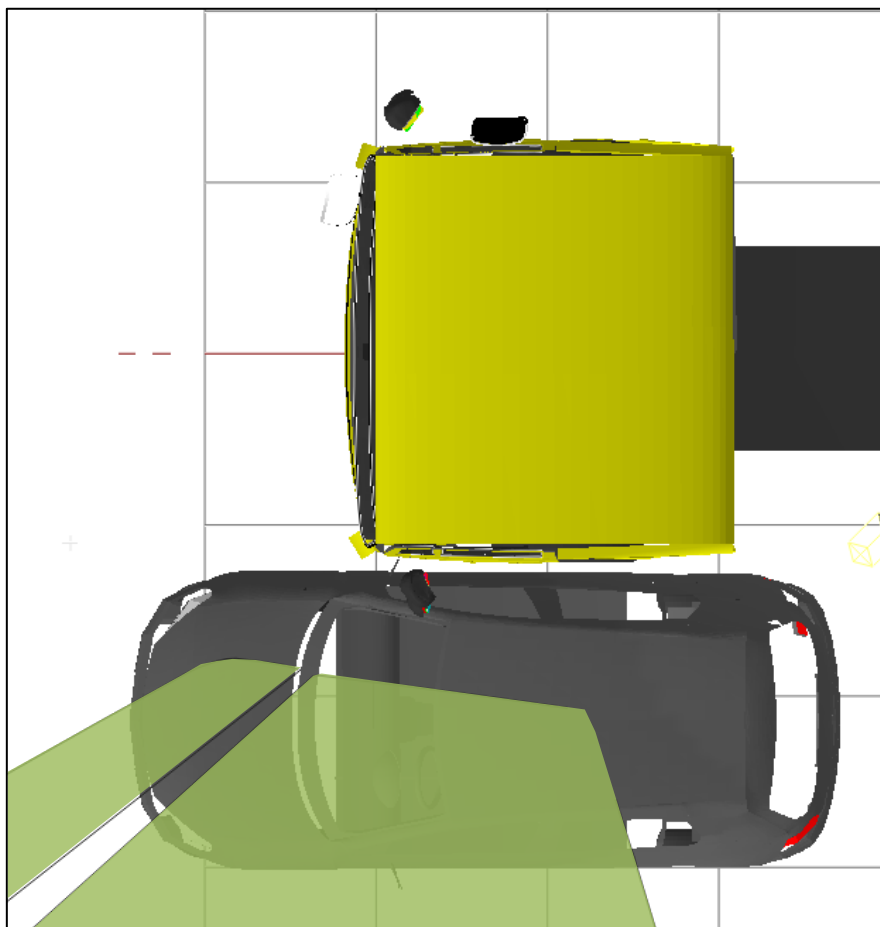

Figure 39. Plan view. The car can be seen by the Category N<sub>3</sub> vehicle driver when the car is adjacent to the driver's door.

### 3.2.1.6 NEARSIDE (PASSENGER SIDE) VISIBILITY – CYCLIST

With the cyclist visual target positioned to the passenger side there is a much larger blind spot in which the visual target can be hidden. Figure 40 and Figure 41 show that the cyclist can be up to 1903mm from the side of the vehicle and still be hidden from view. In contrast to the driver's side blind spot it is not possible for the driver to view the cyclist even if they move their head.

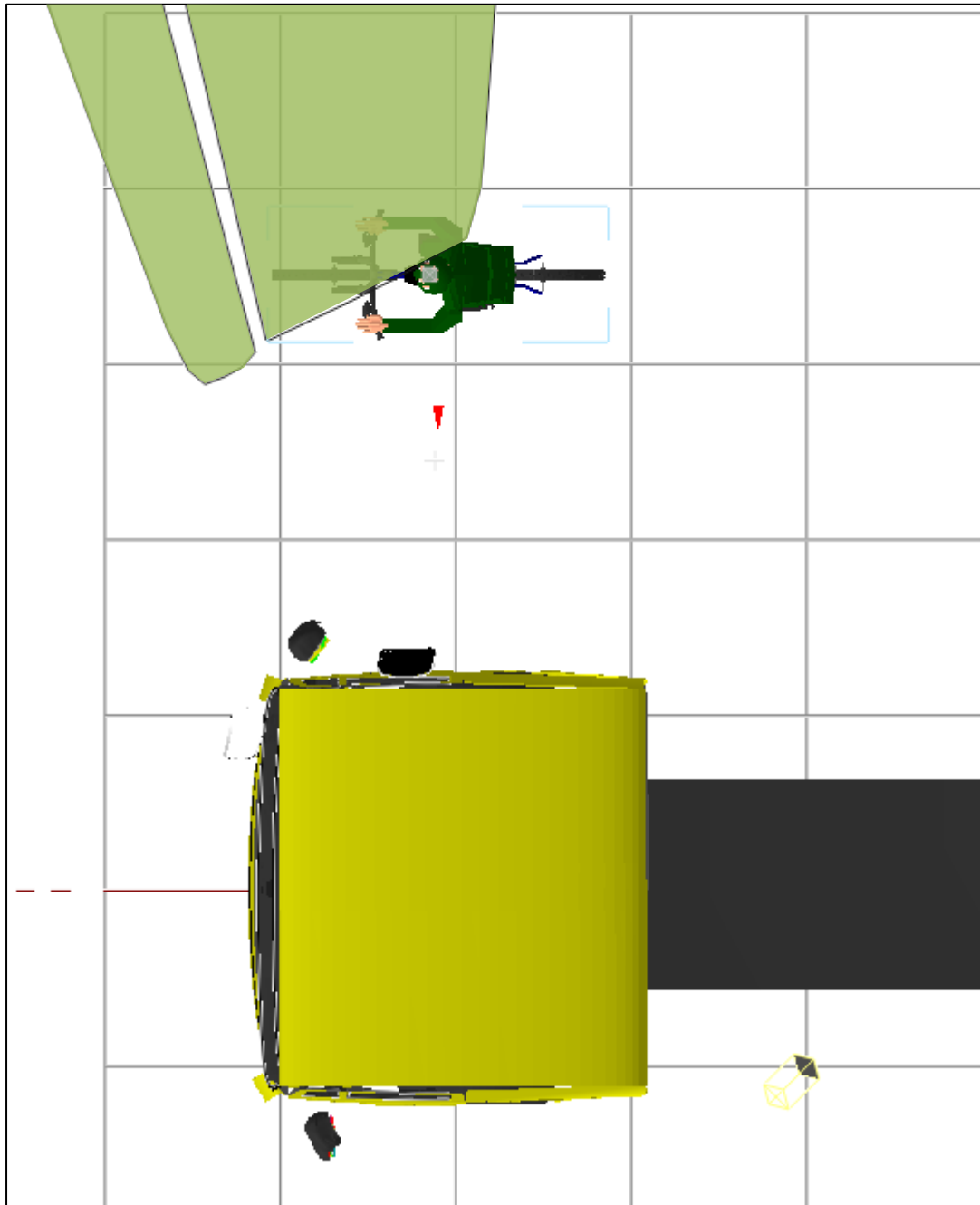

Figure 40. Plan view. The cyclist is 1903mm away from the near side of the vehicle and cannot be seen by the driver with direct vision.

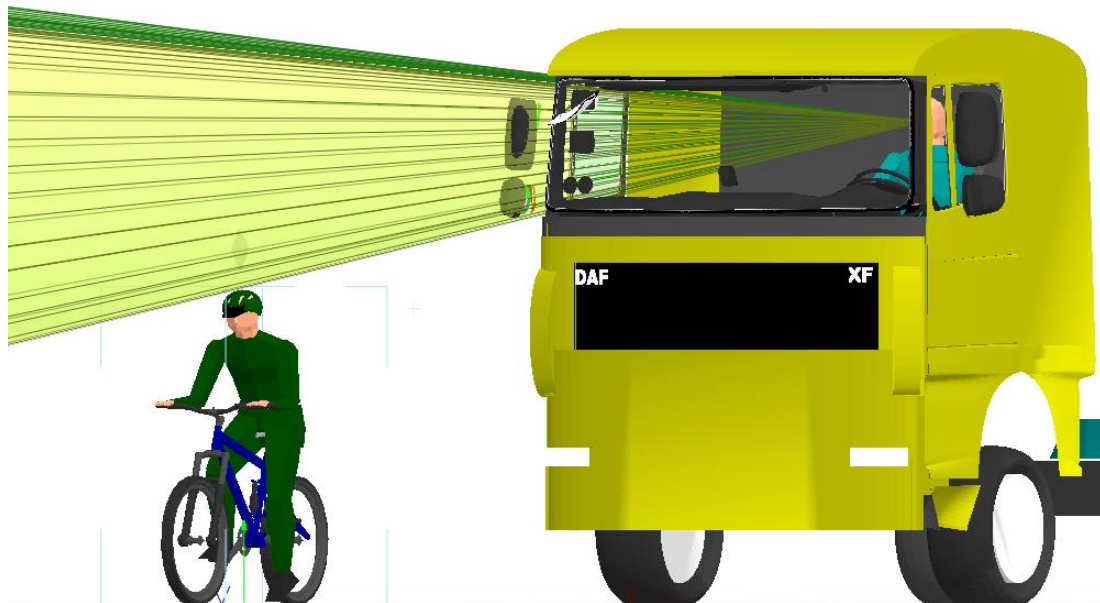

Figure 41. Frontal view. The cyclist is 1903mm away from the near side of the vehicle and cannot be seen by the driver with direct vision.

For nearside visibility of the cyclist target the cyclist (green) can easily be hidden from the driver's view. The cyclist is positioned at 1903mm from the side of the vehicle.

### 3.2.1.7 NEARSIDE (PASSENGER SIDE) VISIBILITY – VW GOLF

Figure 42 and Figure 43 show the visibility to the passenger side of the vehicle with the Volkswagen Golf visual target. The large blind spot to this side of the vehicle is again capable of hiding the visual target from the driver. As the Category M<sub>1</sub> vehicle is lower than the cyclist the vehicle can be positioned even further away and still not be visible. In this instance the car can be 2595mm from the DAF XF cab.

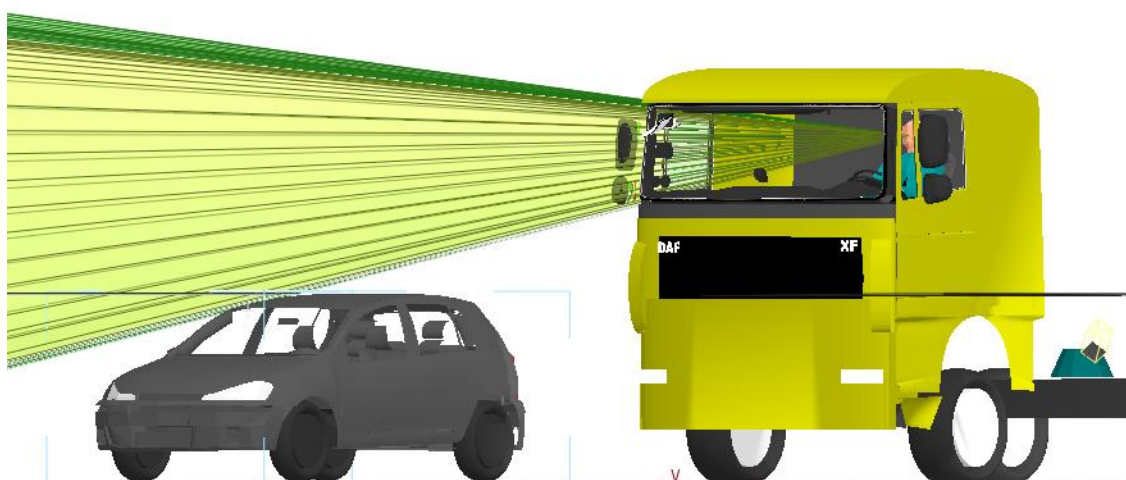
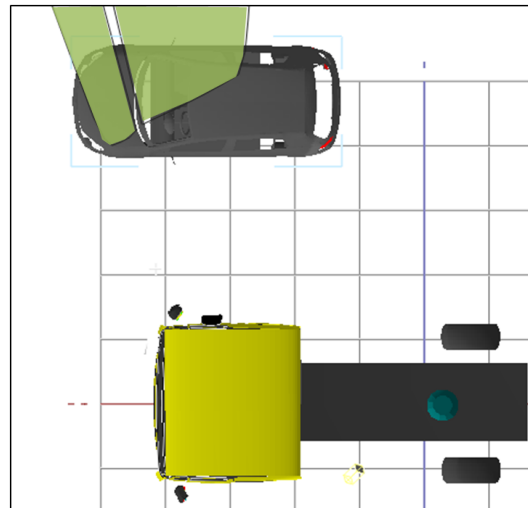
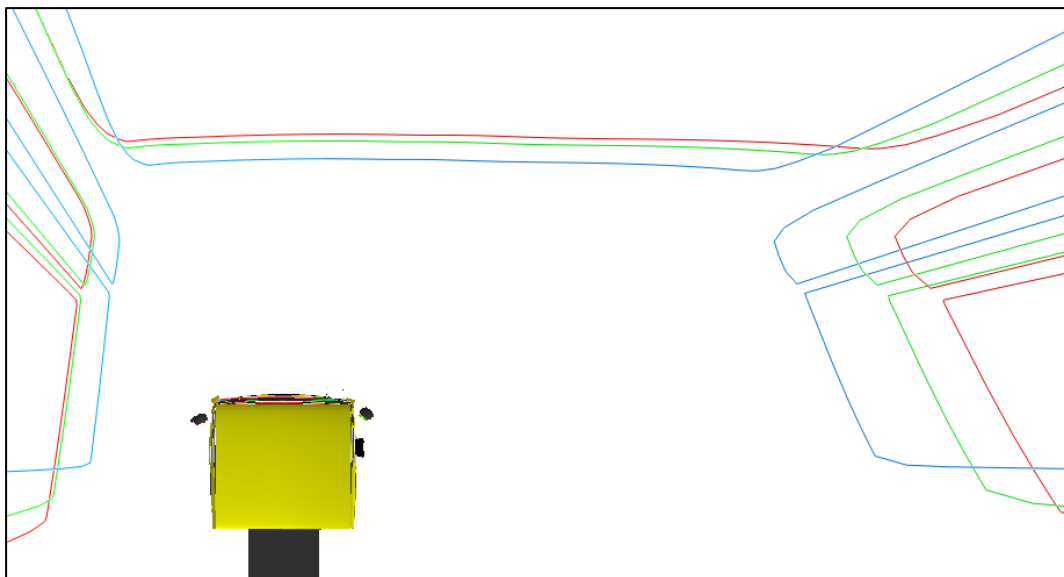

Figure 42. Frontal view. A car can be 2595mm away from the passenger door and cannot be seen by the category N3 vehicle driver.



**Figure 43. Plan view. A car can be 2595mm away from the passenger door and cannot be seen by the category N<sub>3</sub> vehicle driver.**

For nearside visibility of the car target the car can easily be hidden from the driver's view. The car is positioned at 2595mm from the side of the vehicle. Figure 44 shows the variability of the projections on the floor for the three driver eye heights that have been analysed. This shows that the visual targets on the passenger side of the vehicle can be obscured at a distance that is further away from the cab side for the smaller driver (red contours).



**Figure 44. A plan view of the projection of the windscreen and side windows onto the floor for the DAF XF 105 for a range of driver eye positions. Red=smallest driver(4<sup>th</sup>ile UK male stature), Green=average sized driver (50<sup>th</sup>ile UK male Stature), and Blue=tallest driver (99<sup>th</sup>ile UK male stature)**

### 3.2.2 FKA CONCEPT

The following sections show the evaluation of the FKA Concept Prototype vehicle.

#### 3.2.2.1 DIRECT VISION – APERTURE PROJECTIONS

The following projections illustrate the extent of direct vision afforded to the driver via windows or other apertures in the cab. Figure 45 shows a top-down view of all of the window projections for the FKA Concept cab. The image on the right of Figure 45 shows the areas of these projections that intersect with the ground.

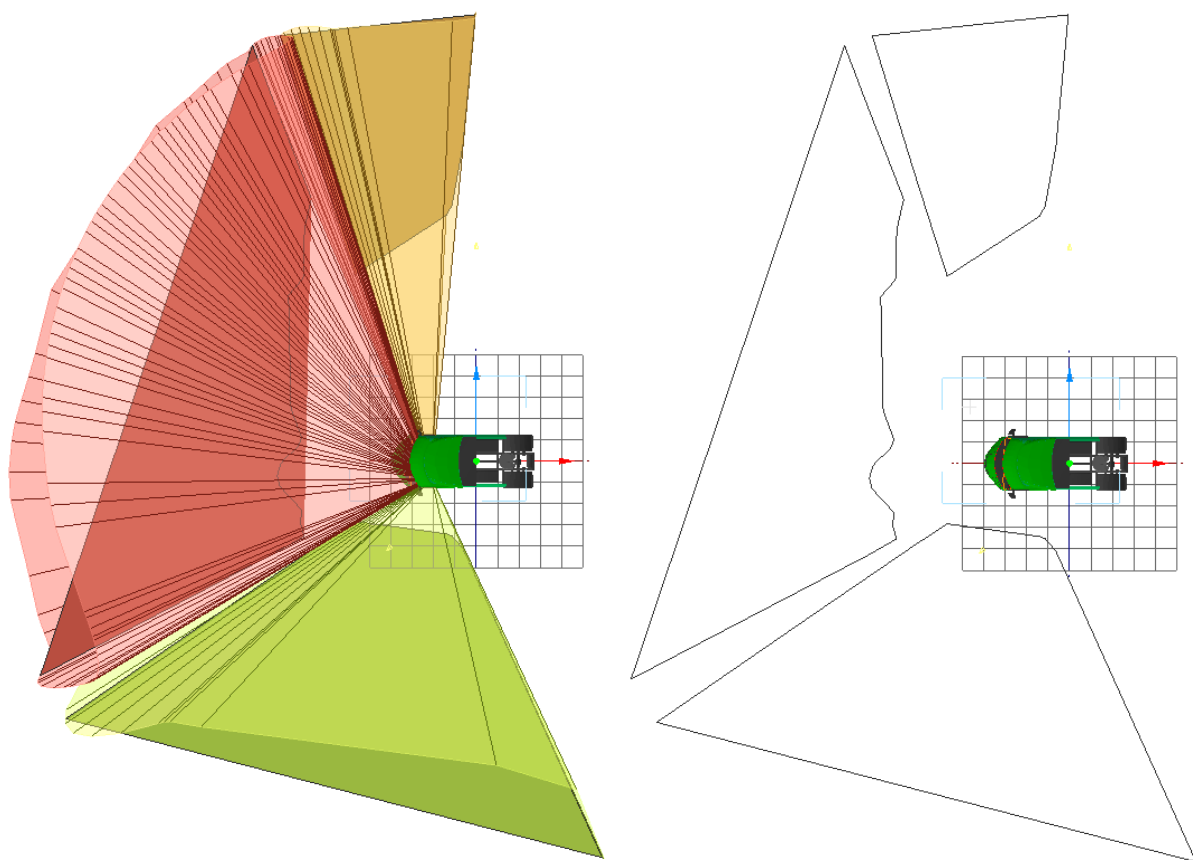

Figure 45. Ground plane FOV projections

Figure 46, Figure 47 and Figure 48 illustrate that the projections are conical in shape, projecting from the driver's eye point through the window aperture and beyond. Due to this conical nature some areas close to the vehicle are not visible. Anything inside the conical projection would be visible to the driver, anything not inside the projection would not be visible without the driver moving or through indirect vision such as a mirror.



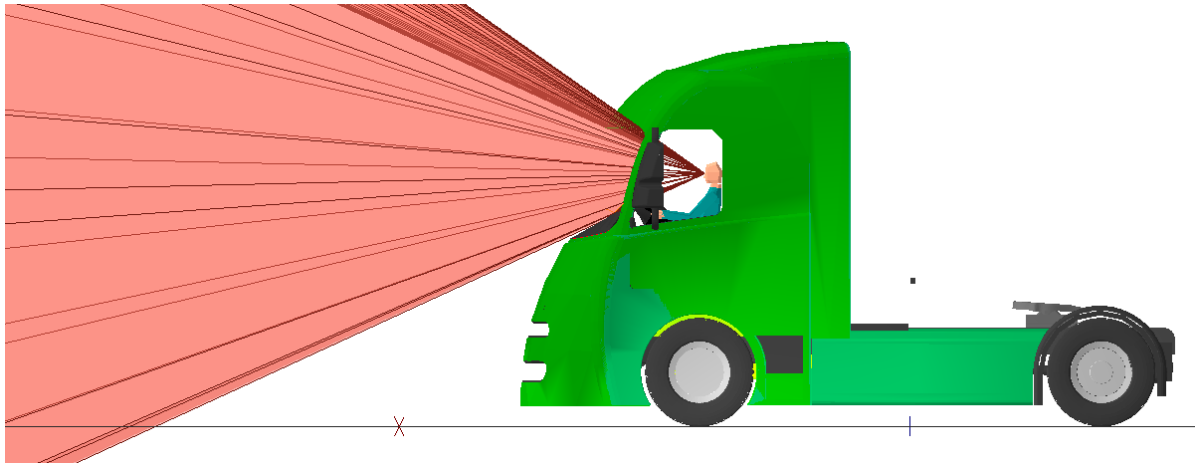

Figure 46. FOV projections to the front of the vehicle

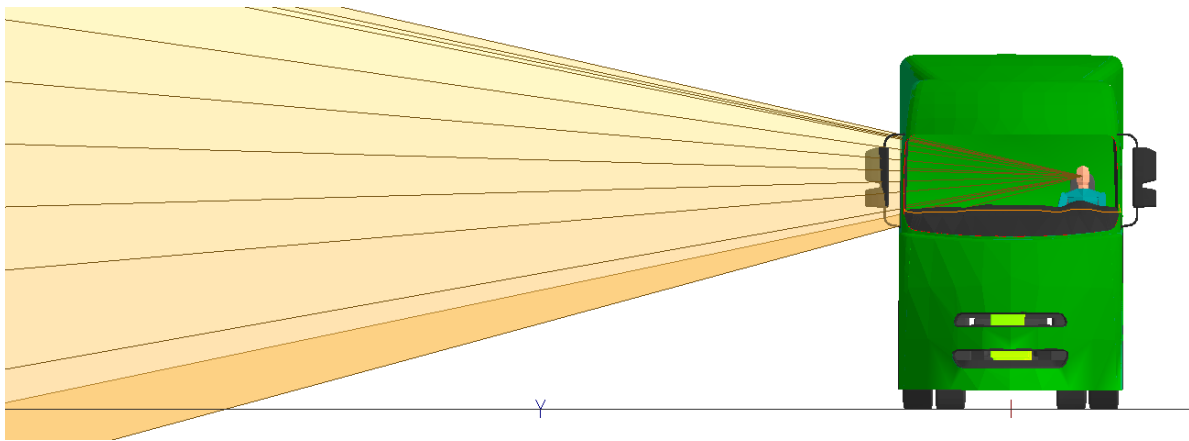

Figure 47. FOV projections to the right of the vehicle

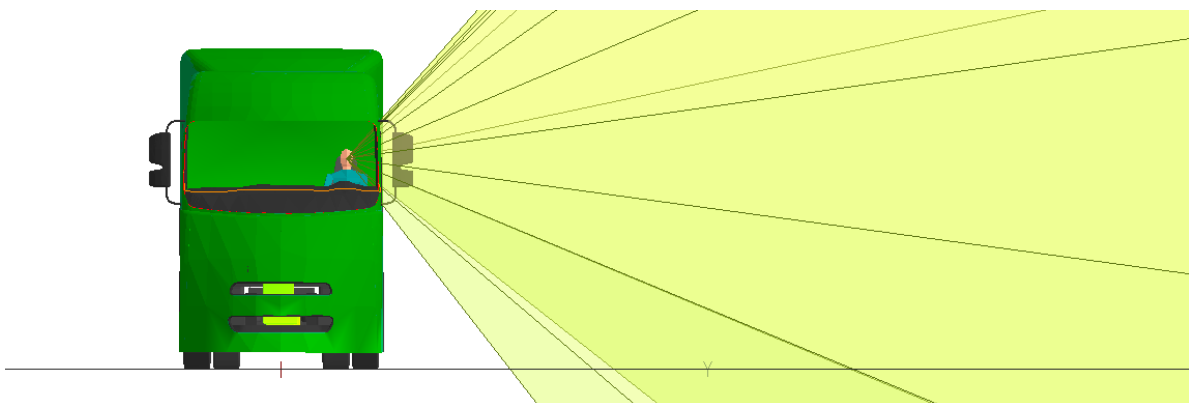

Figure 48. FOV projections to the left of the vehicle

### 3.2.2.2 FORWARD VISIBILITY – PEDESTRIAN

Figure 30 shows the visible areas in proximity to the cab taken at a height equivalent to the stature of a 50<sup>th</sup> %ile UK male (1755mm). The intersection of the projections and this plane are shaded green. The uneven edge closest to the vehicle is due to obscuration from the dashboard of the vehicle that occludes the lower edge of the windscreen.

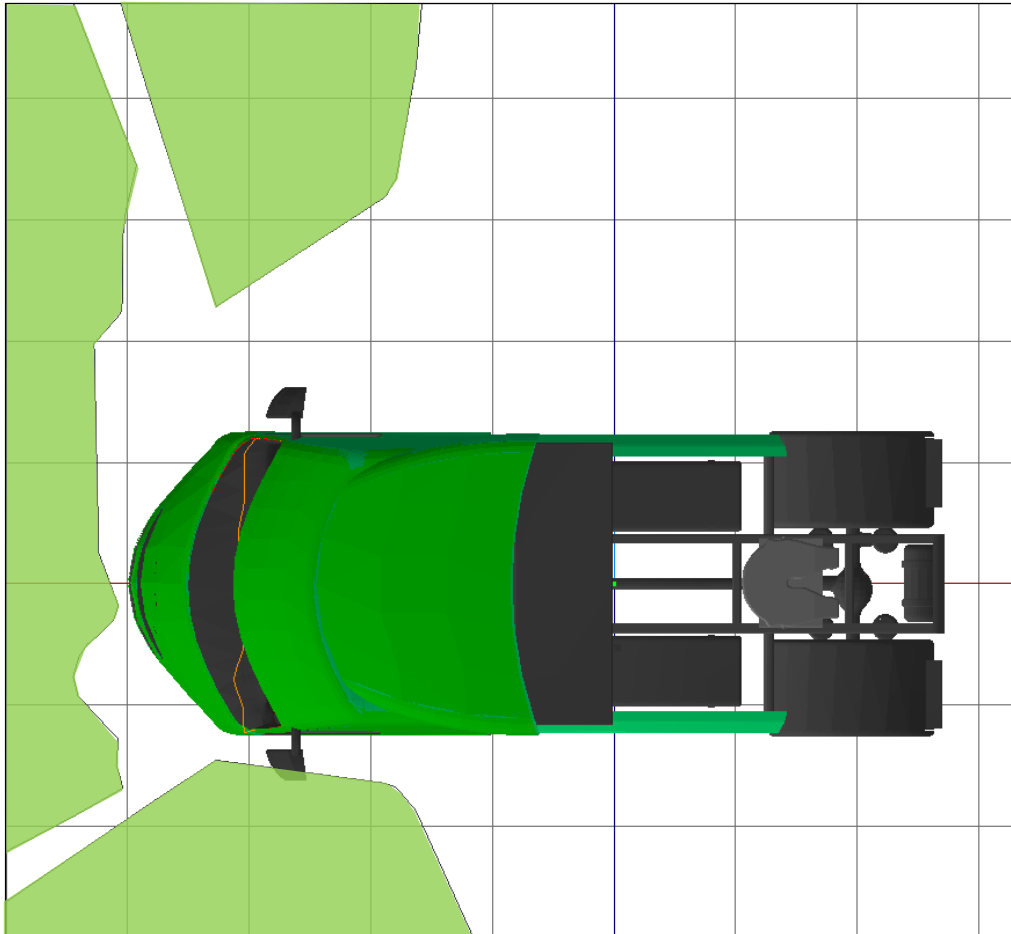

Figure 49. Ground plane +1755mm FOV projections

From the figure it is clear that the visible areas at a height representative of a pedestrian are closer to the vehicle than those taken at ground level shown in Figure 45. However Figure 50 and Figure 52 show that there is a clear space between the front of the vehicle and the near edge of the visible area in which a pedestrian could be hidden. Unlike the DAF XF the curved front of the vehicle does improve vision at the front centre of the vehicle where it is possible to just see the pedestrian visual target (Figure 51).

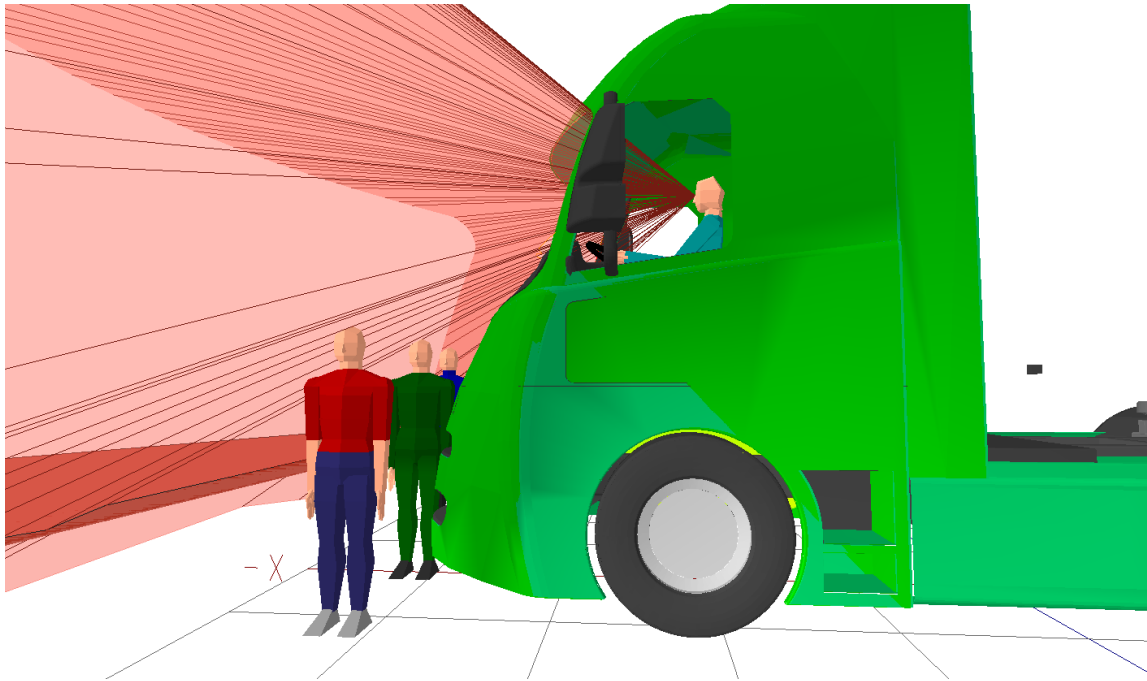

Figure 50. 3D view of the pedestrians positioned to the front of the vehicle

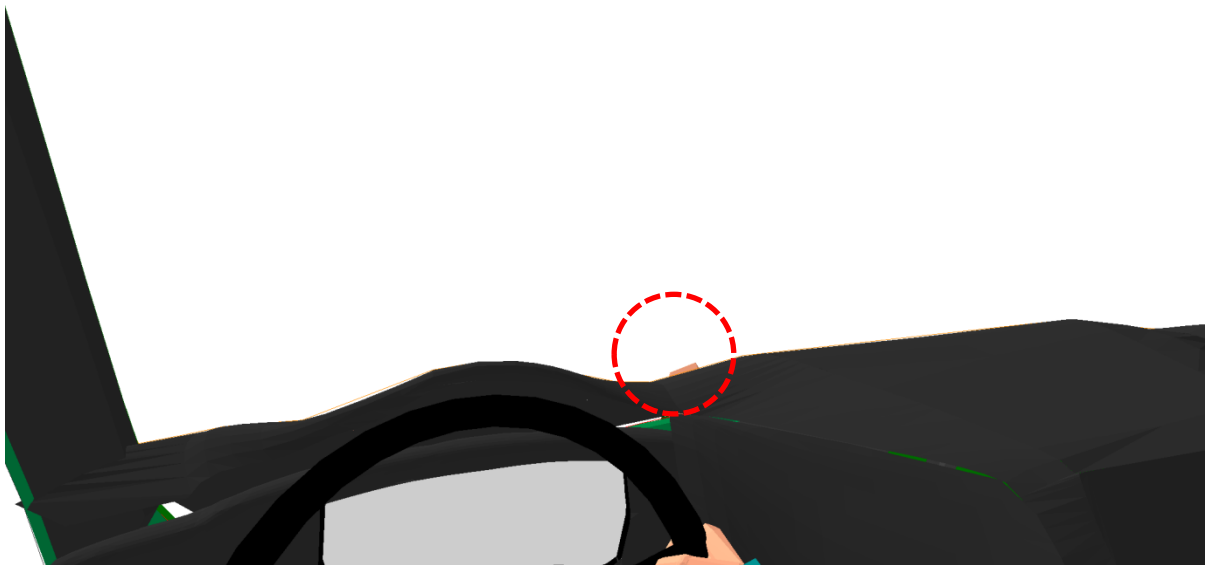

Figure 51. Driver's view of the pedestrians positioned to the front of the vehicle, only the central (green) pedestrian is visible

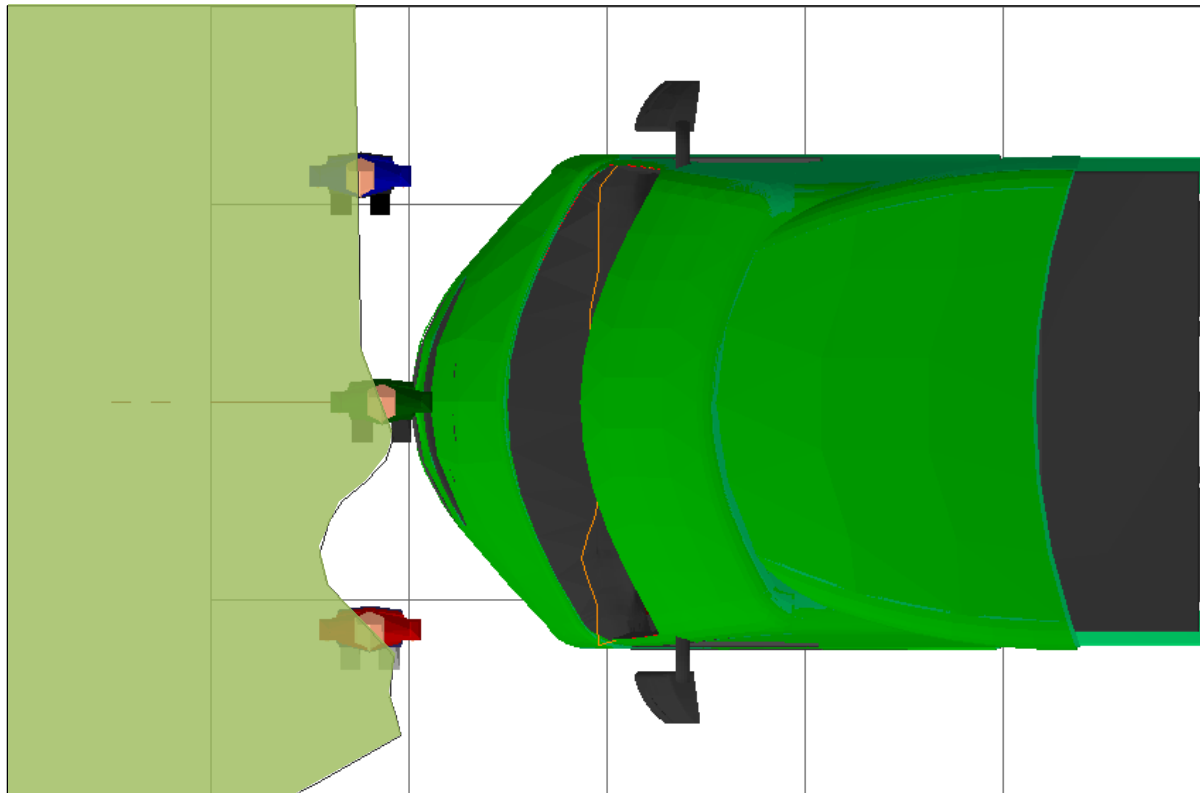

Figure 52. 2D plan view of the pedestrians positioned to the front of the vehicle overlaid with the visibility at the ground plane +1755mm

For forwards visibility of the pedestrian targets, the central (green) pedestrian is always visible, the right (blue) and left (red) pedestrians can be hidden from the driver's view. The blue pedestrian is positioned at 530mm from the front of the vehicle, and the red pedestrian is positioned at 485mm from the front of the vehicle. Therefore for forward vision to pedestrian visual targets the FKA concept is an improvement upon the baseline DAF XF.

### 3.2.2.3 FORWARD VISIBILITY – CYCLIST

Figure 53 shows the visible areas in proximity to the cab taken at a height equivalent to the stature of a 50<sup>th</sup> %ile UK male cyclist (1738mm). The intersection of the projections and this plane are shaded green.

Figure 54 and Figure 56 show the potential for the cyclist visual target to be hidden from the driver. The three cyclists shown are all very close to the front of the vehicle and as shown in Figure 55, only the blue cyclist, to the nearside (passenger side) of the vehicle is completely obscured. Due to the proximity of the cyclists to the vehicle it is unlikely that this situation would occur. Cyclists would position themselves further forward and in doing so would then be visible to the driver.

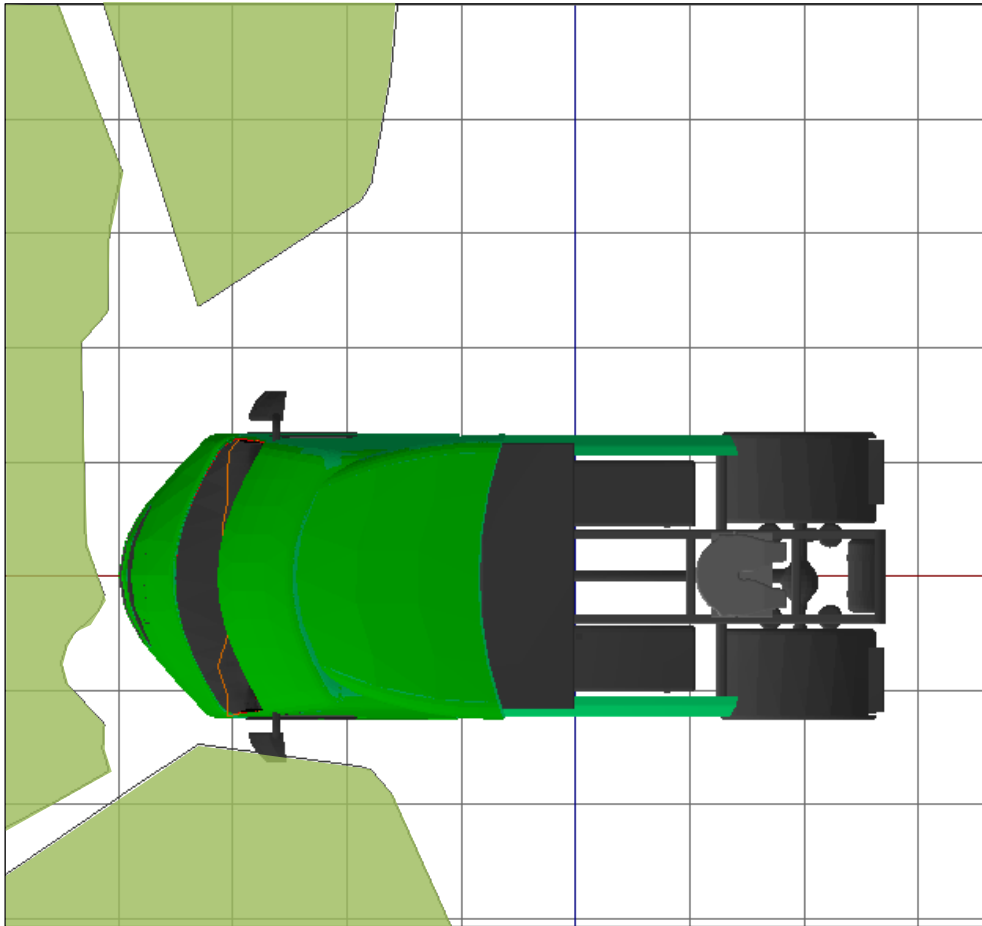

Figure 53. Ground plane +1738mm FOV projections

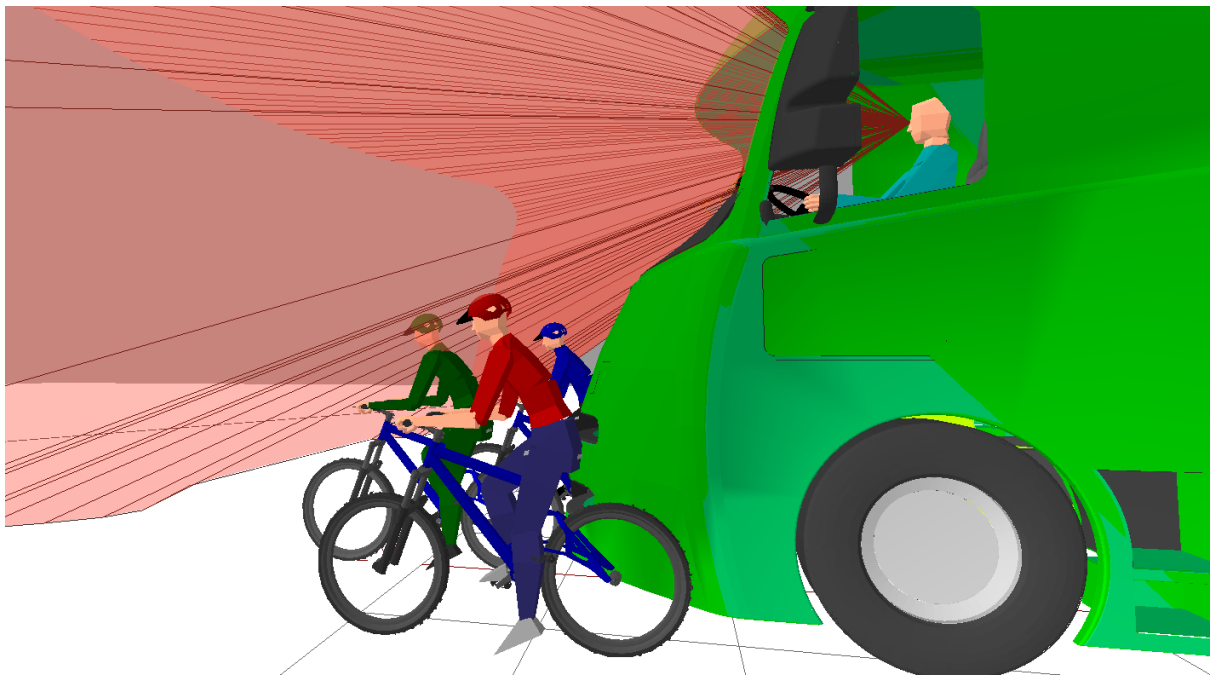

Figure 54. 3D view of the cyclists positioned to the front of the vehicle

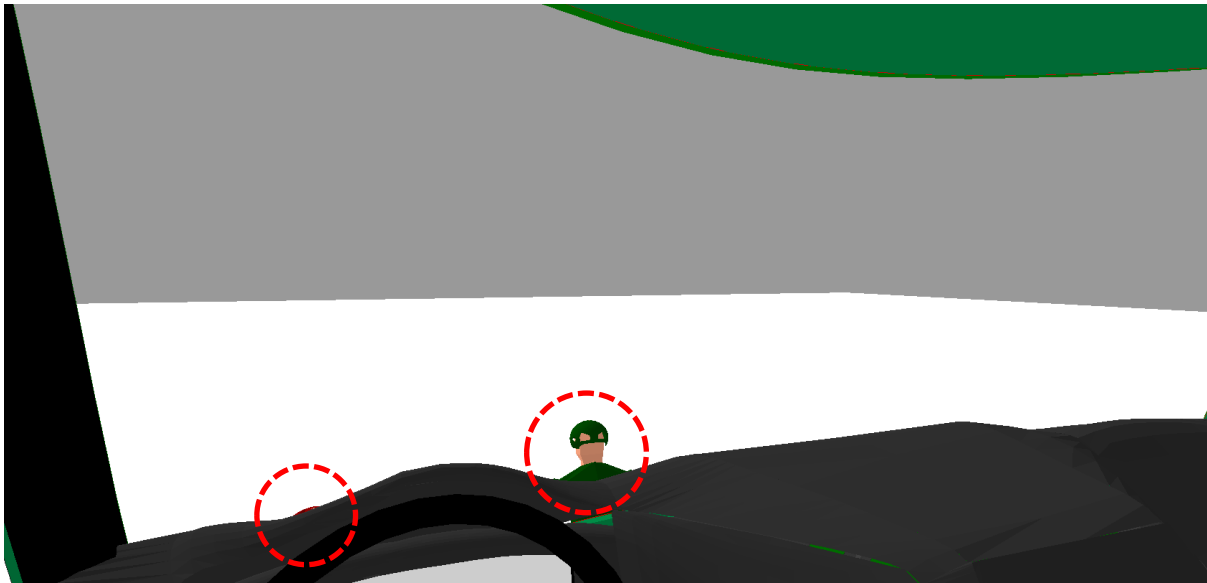

Figure 55. Driver's view of the cyclists positioned to the front of the vehicle, the central (green) and left (red) cyclists are visible

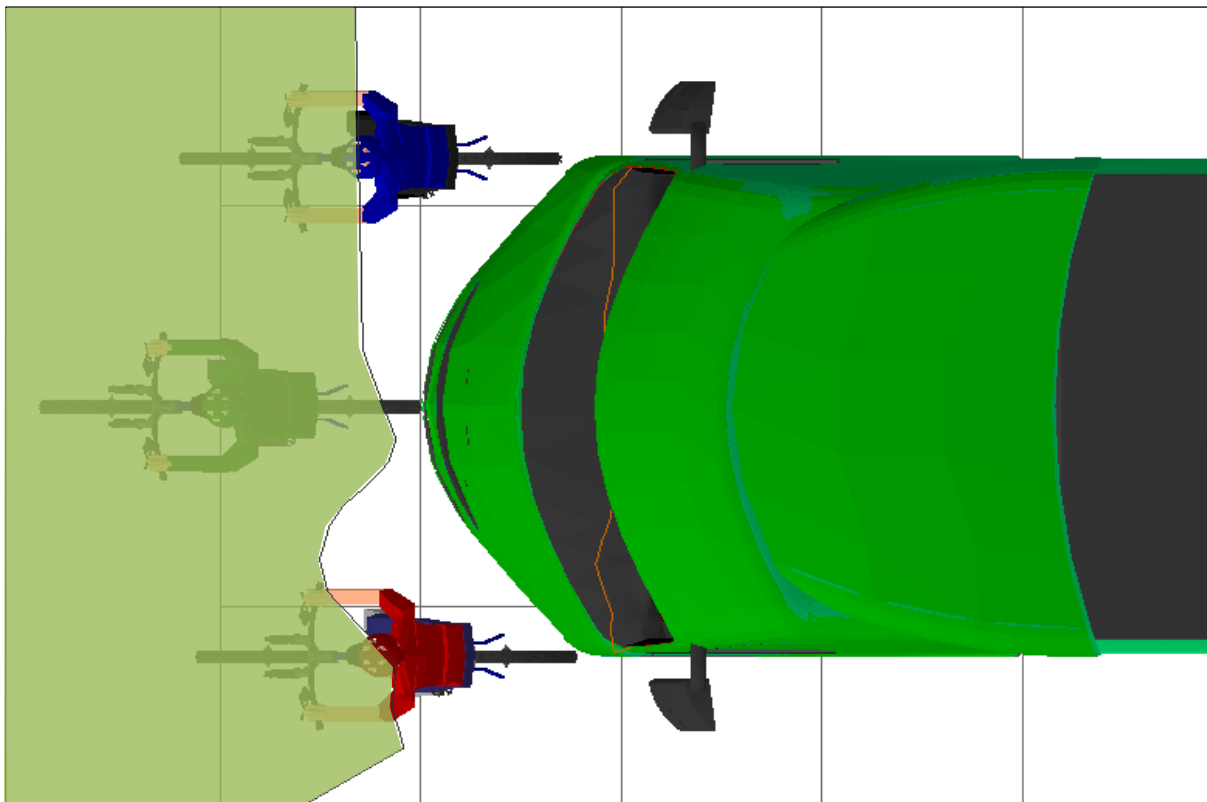

Figure 56. 2D plan view of the cyclists positioned to the front of the vehicle overlaid with the visibility at the ground plane +1738mm

For forwards visibility of the cyclist targets, the central (green) cyclist and the left (red) cyclist are always visible, the right (blue) cyclist can be hidden from the driver's view. The blue cyclist is positioned at 150mm from the front of the vehicle.

### 3.2.2.4 OFFSIDE (DRIVER SIDE) VISIBILITY – CYCLIST

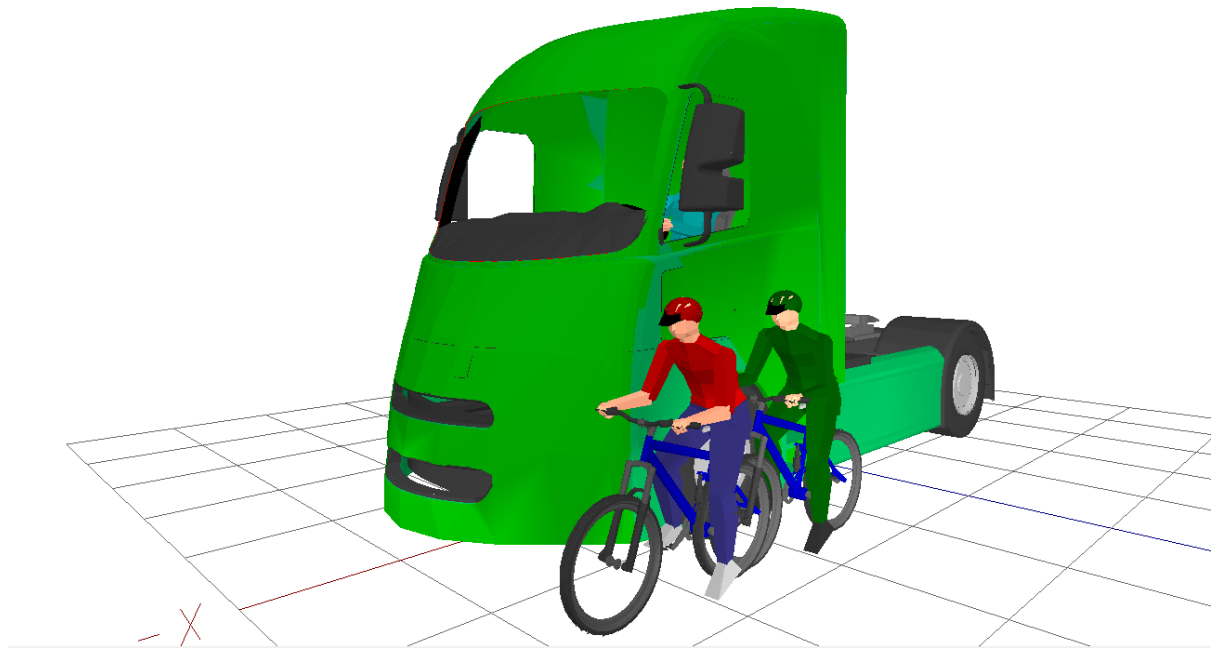

Figure 57. 3D view of cyclists positioned to the offside of the vehicle

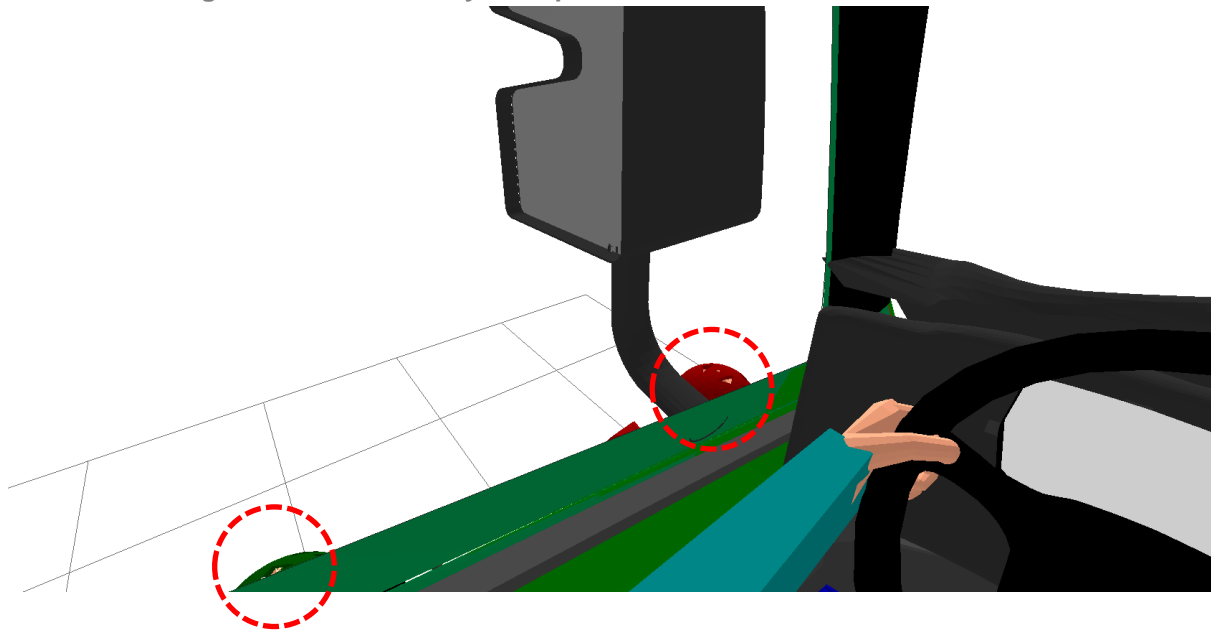

Figure 59 and Figure 60. The projections show that there is no blind spot to the driver's side of the vehicle that could obscure the cyclist visual targets as presented. Figure 59 shows that even with the cyclist touching the side of the cab they would still be visible to the driver. Again this is an improvement when compared to the baseline DAF XF where cyclists could be obscured completely when in close proximity to the vehicle.

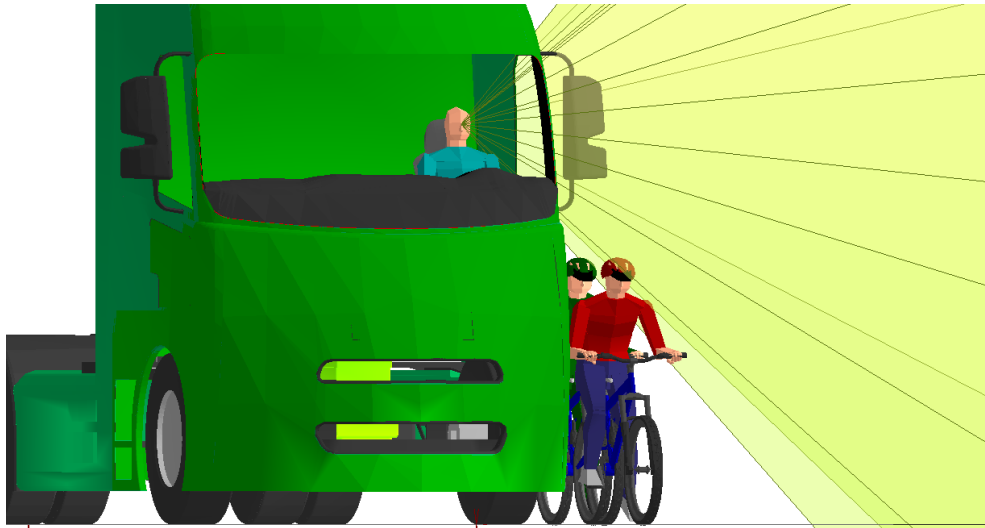

Figure 58. 3D view of cyclists positioned to the offside of the vehicle

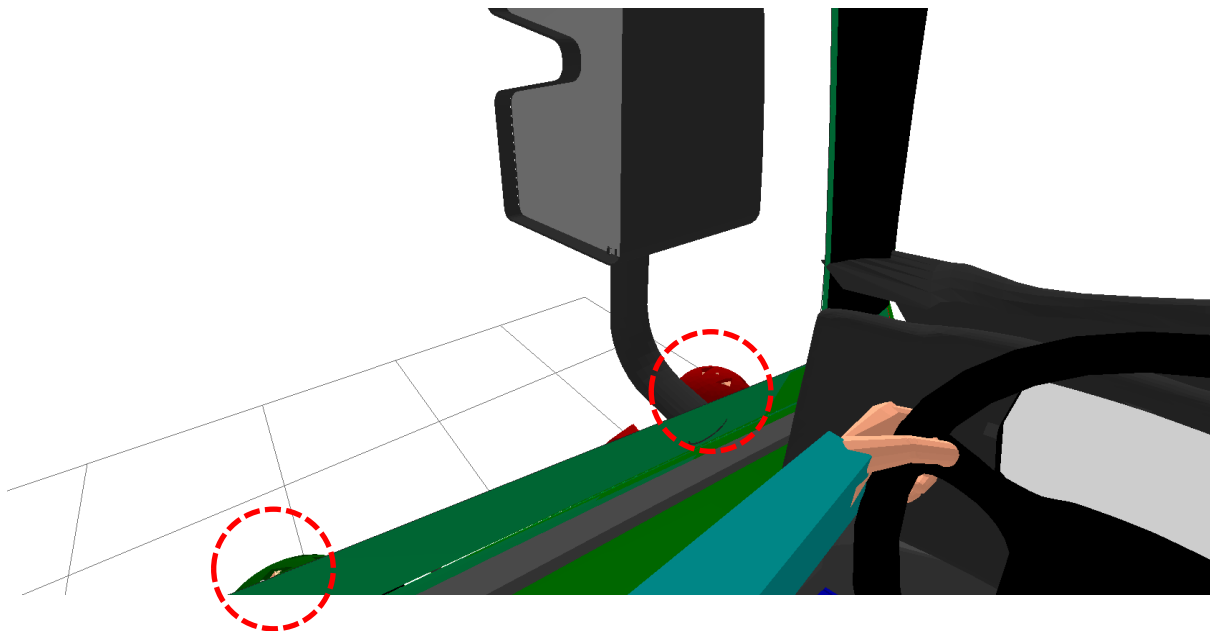

Figure 59. Driver's view of the cyclists positioned to the offside of the vehicle, the rear (green) and front (red) cyclists are visible



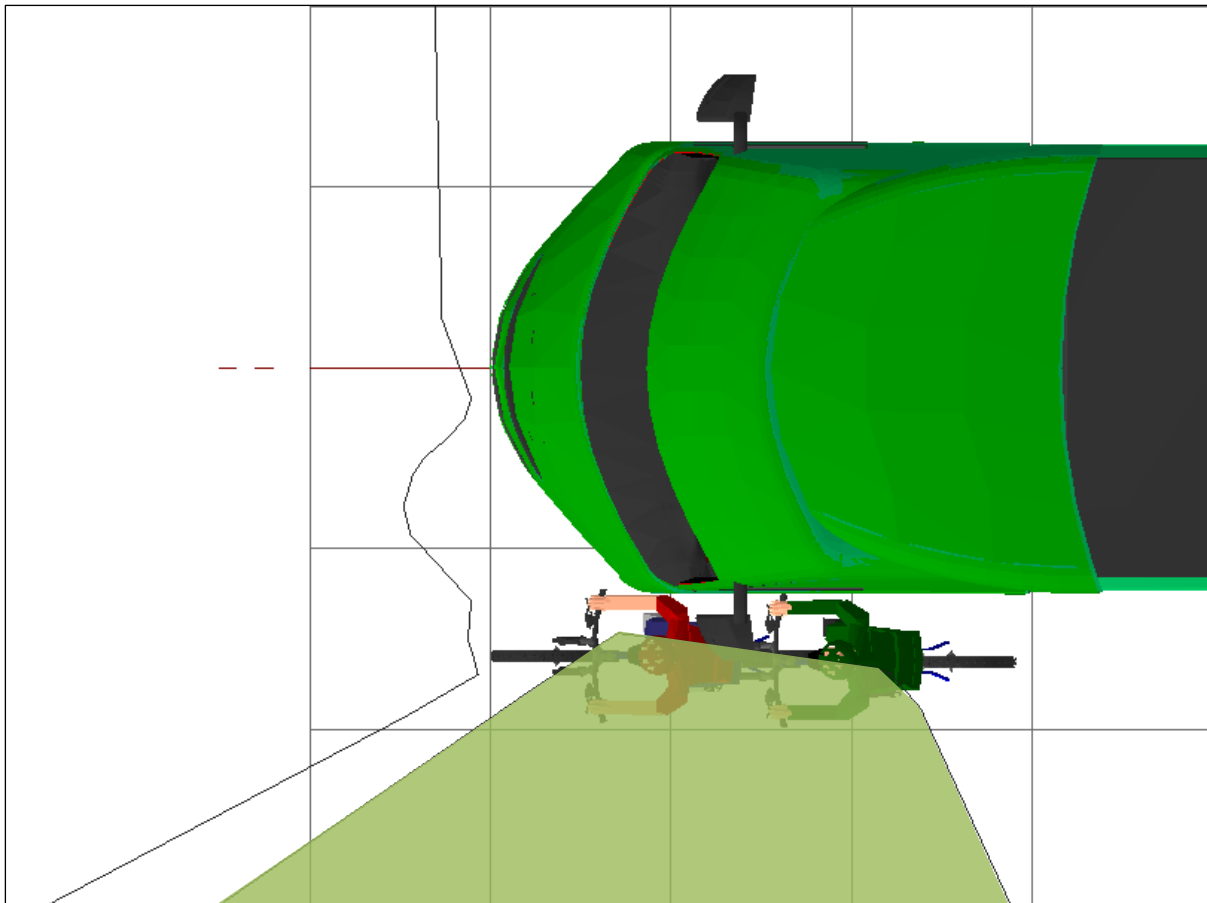

Figure 60. 2D plan view of the cyclists positioned to the offside of the vehicle overlaid with the visibility at the ground plane +1738mm

### 3.2.2.5 OFFSIDE (DRIVER SIDE) VISIBILITY – VW GOLF

Figure 61 shows the visible areas in proximity to the cab taken at the height of a 2010 Volkswagen golf (1450mm). The intersection of the projections and this plane are shaded green.

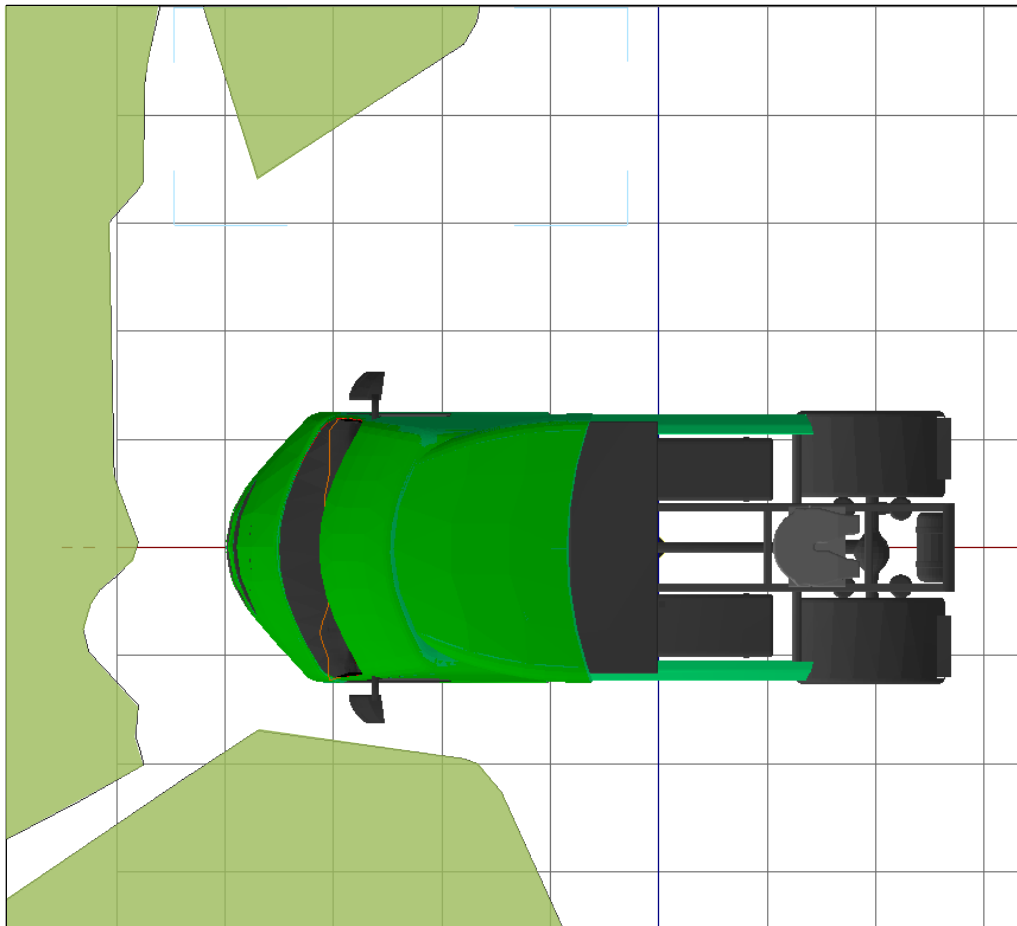

Figure 61. Ground plane +1450mm FOV projections

Figure 62, Figure 63, Figure 64 and Figure 65 show the visibility to the driver's side of the vehicle with the Volkswagen Golf visual target. In this instance the car visual target as defined here is always visible to driver through the side windows.

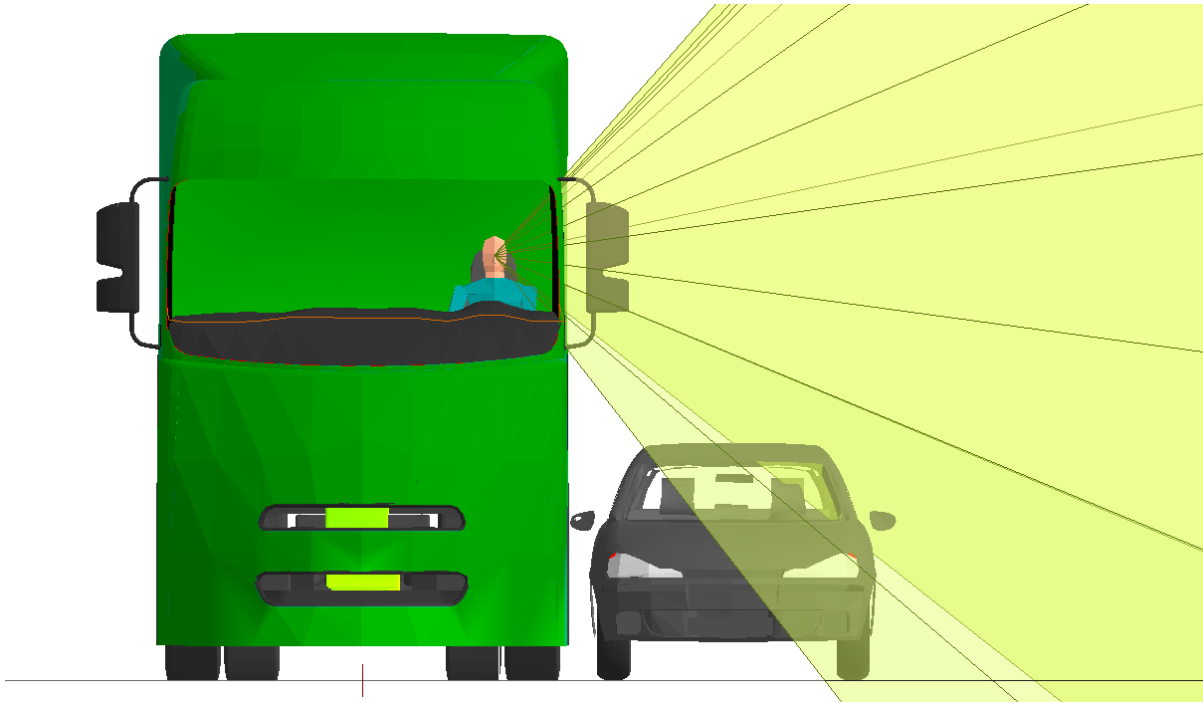

Figure 62. 3D view of the Volkswagen Golf positioned to the offside of the vehicle

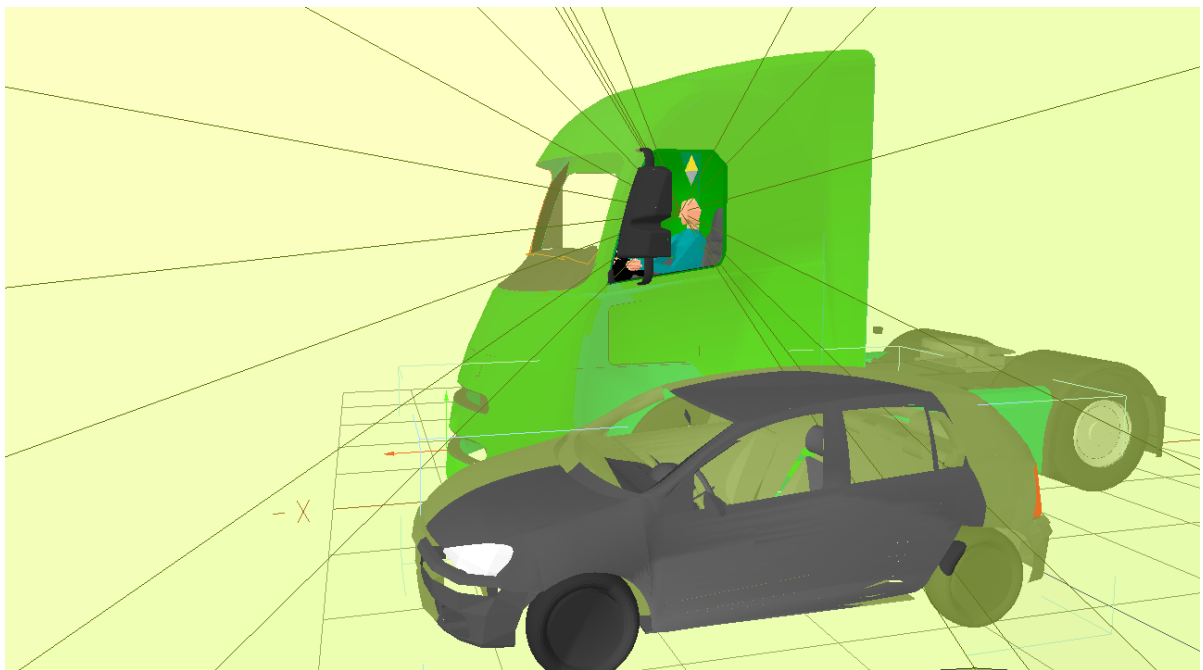

Figure 63. 3D view of the Volkswagen Golf positioned to the offside of the vehicle, clearly showing the amount of the vehicle that would be visible

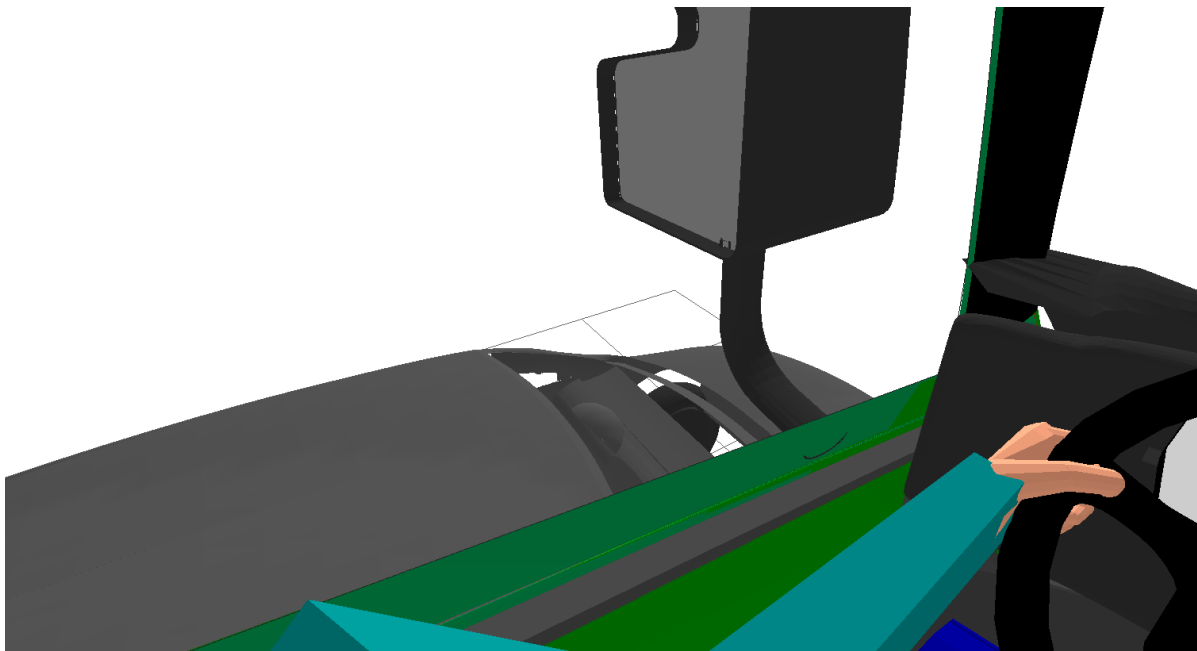

Figure 64. Driver's view of the Volkswagen Golf positioned to the offside of the vehicle, clearly showing the amount of the vehicle that would be visible

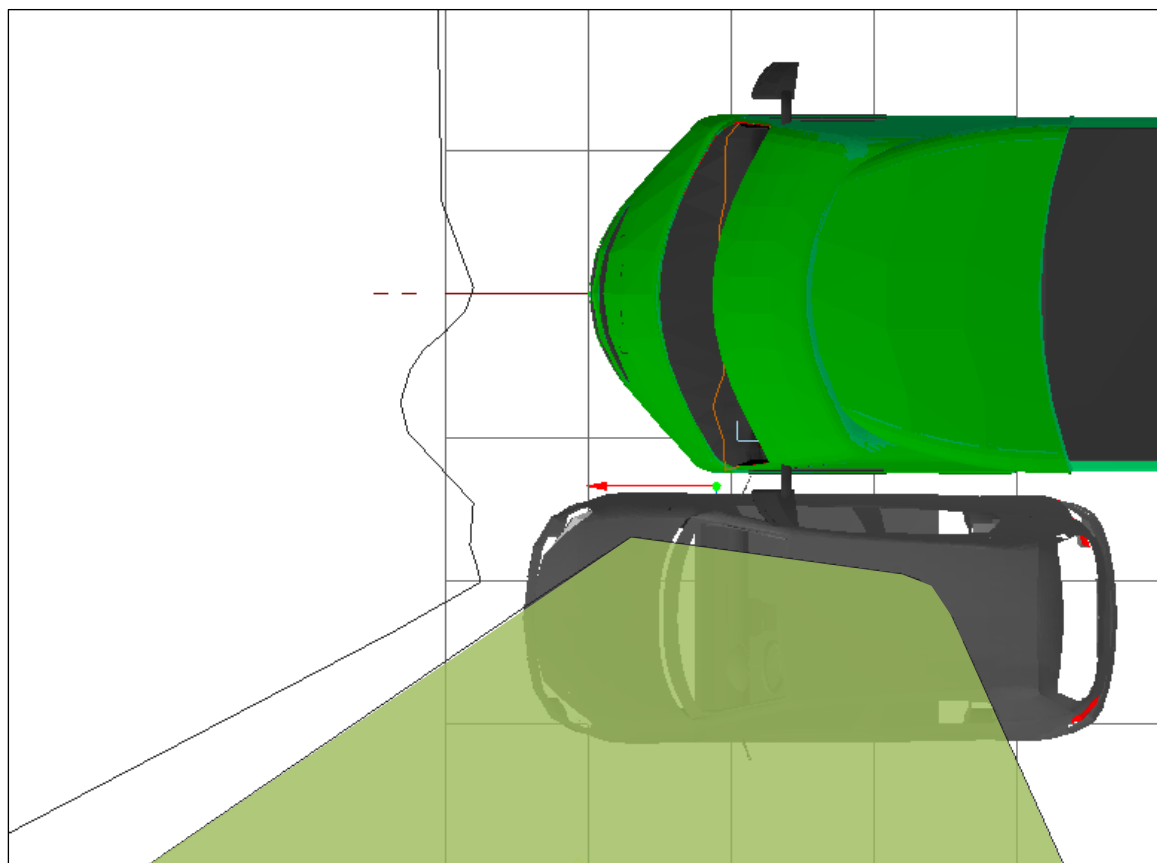

Figure 65. 2D plan view of the Volkswagen Golf positioned to the offside of the vehicle overlaid with the visibility at the ground plane +1450mm

### 3.2.2.6 NEARSIDE (PASSENGER SIDE) VISIBILITY – CYCLIST

With the cyclist visual target positioned to the passenger side there is a larger blind spot in which the visual target can be hidden. Figure 67 and Figure 68 show that the cyclist can be up to 1458mm from the side of the vehicle and still be hidden from view. This is a smaller blind spot than that exhibited by the DAF XF but still sufficient to easily hide a cyclist.



Figure 66. 3D view of cyclist positioned to the nearside of the vehicle

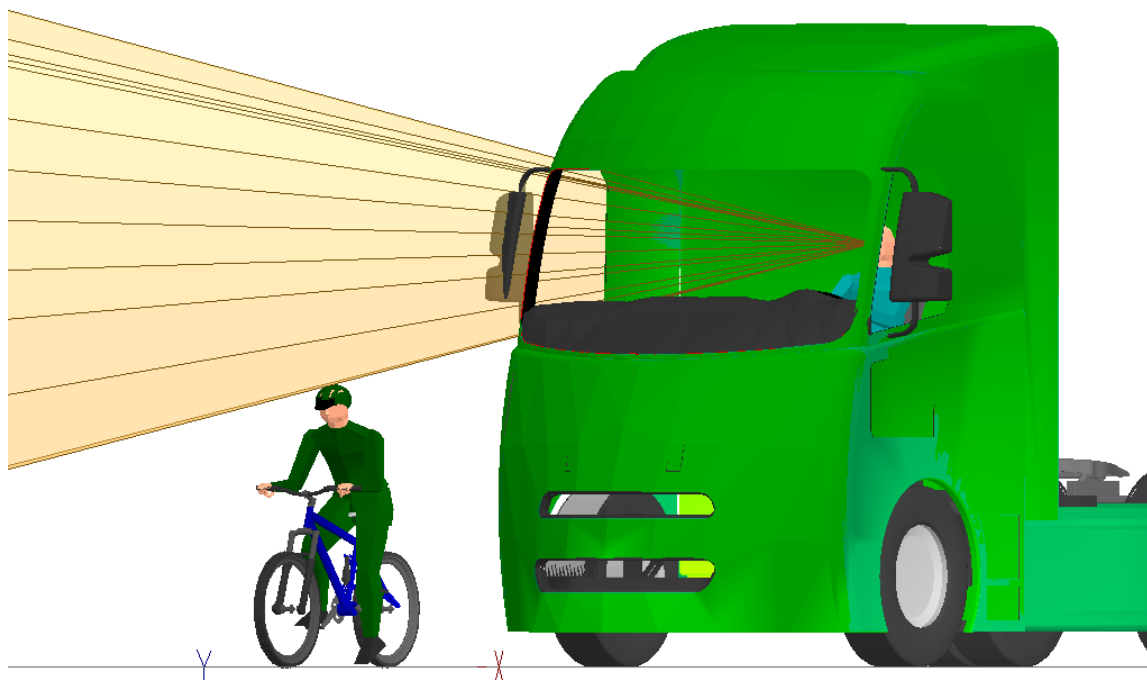

Figure 67. 3D view of cyclist positioned to the nearside of the vehicle

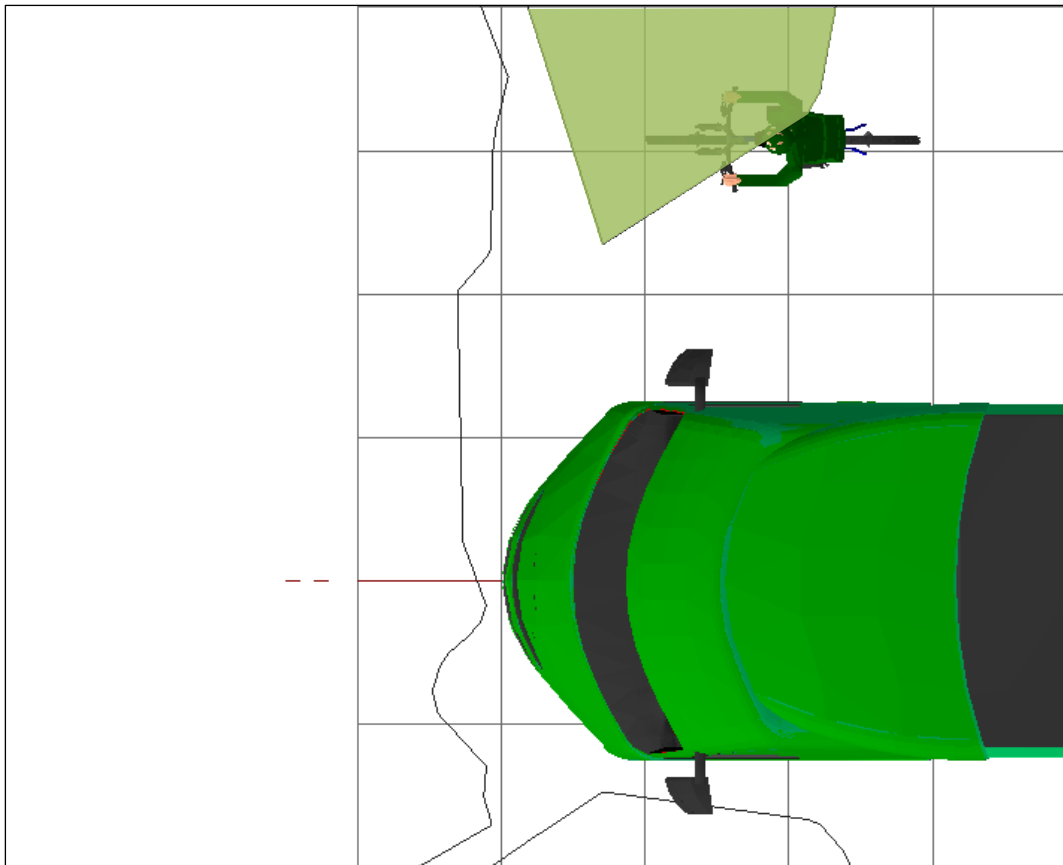

Figure 68. 2D plan view of the cyclist positioned to the nearside of the vehicle overlaid with the visibility at the ground plane +1738mm

For nearside visibility of the cyclist target the cyclist (green) can easily be hidden from the driver's view. The cyclist is positioned at 1458mm from the side of the vehicle.

### 3.2.2.7 NEARSIDE (PASSENGER SIDE) VISIBILITY – VW GOLF

Figure 69, Figure 70 and Figure 71 show the visibility to the passenger side of the vehicle with the Volkswagen Golf visual target. The large blind spot to this side of the vehicle is again capable of hiding the visual target from the driver. As the Category M<sub>1</sub> vehicle is lower than the cyclist the vehicle can be positioned even further away and still not be visible. In this instance the car can be 1874mm from the FKA prototype cab.

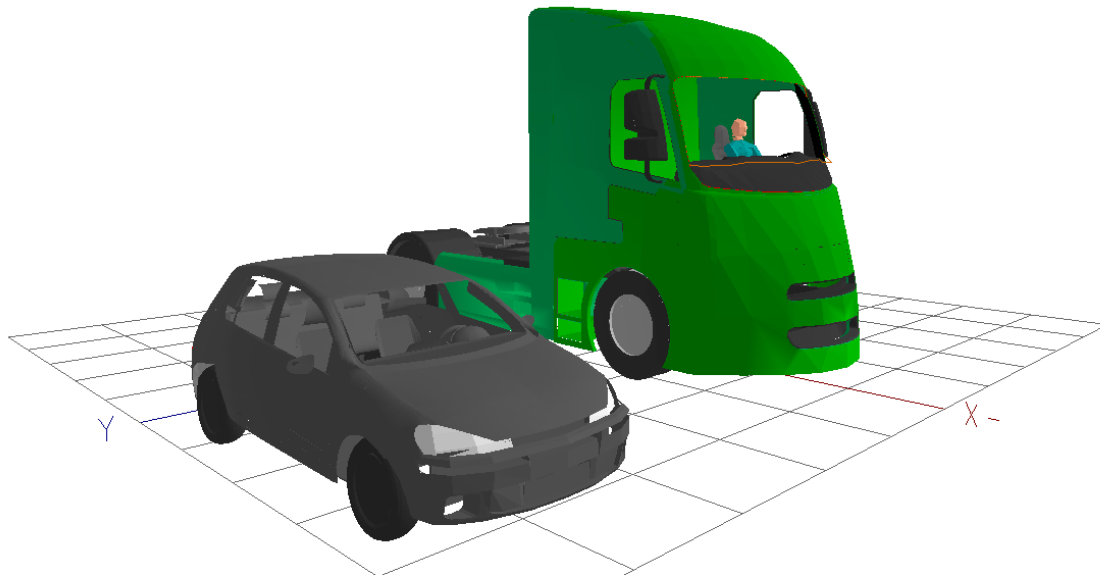

Figure 69. 3D view of the Volkswagen Golf positioned to the nearside of the vehicle

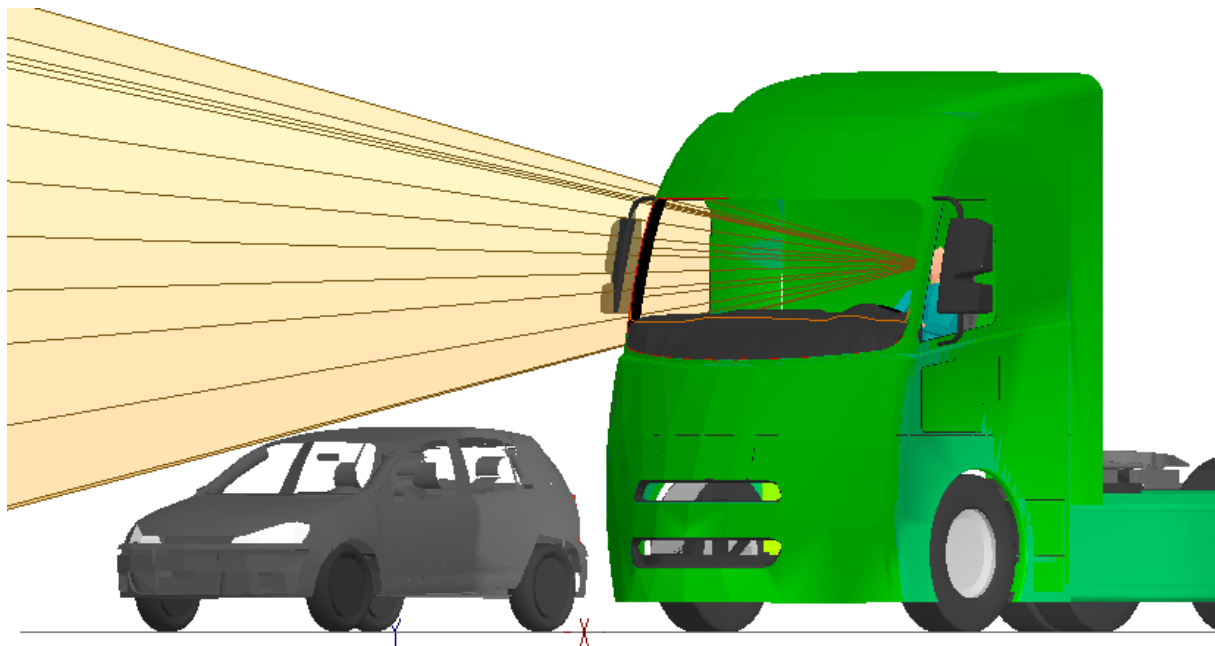

Figure 70. 3D view of the Volkswagen Golf positioned to the nearside of the vehicle

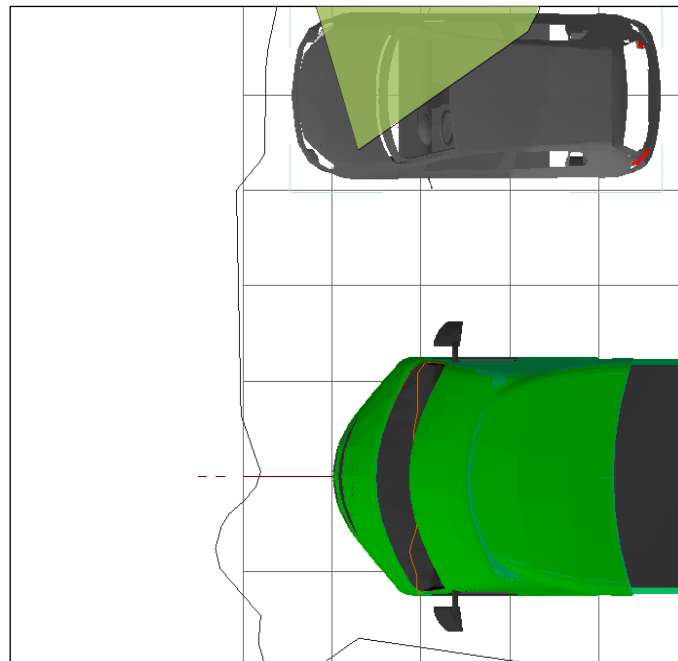

Figure 71. 2D plan view of the Volkswagen Golf positioned to the nearside of the vehicle overlaid with the visibility at the ground plane +1450mm

For nearside visibility of the car target the car can easily be hidden from the driver's view. The car is positioned at 1874mm from the side of the vehicle. Figure 72 shows the variability of the projections on the floor for the three driver eye heights that have been analysed. This shows that the visual targets on the passenger side of the vehicle can be obscured at a distance that is further away from the cab side for the smaller driver (red contours).

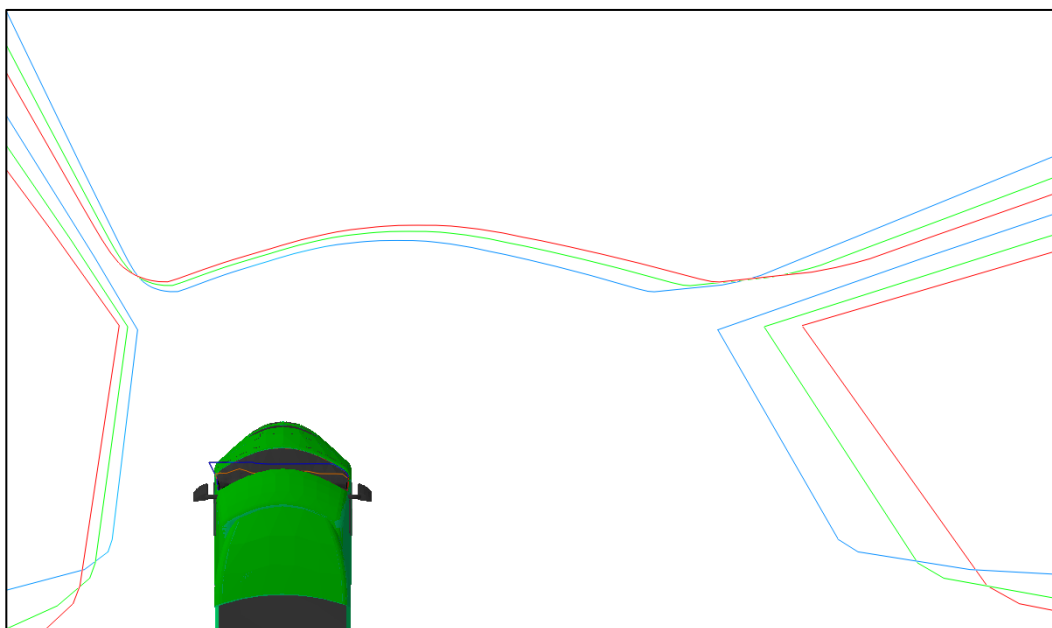

Figure 72. A plan view of the projection of the windscreen and side windows onto the floor for the FKA concept for a range of driver eye positions. Red=smallest driver, Green=average sized driver, and Blue=tallest driver



### 3.2.3 FKA CONCEPT ITERATION 1 – ADDITIONAL WINDOW APERTURES AND MODIFIED DASHBOARD

The following sections show the evaluation of the FKA Concept Iteration 1.

#### 3.2.3.1 DIRECT VISION – APERTURE PROJECTIONS

The following projections illustrate the extent of direct vision afforded to the driver via windows or other apertures in the cab. Figure 73 shows a top-down view of all of the window projections for the FKA Concept Iteration 1 cab. The image on the right of Figure 73 shows the areas of these projections that intersect with the ground. The additional glazed area projections are visible to the nearside of the cab.

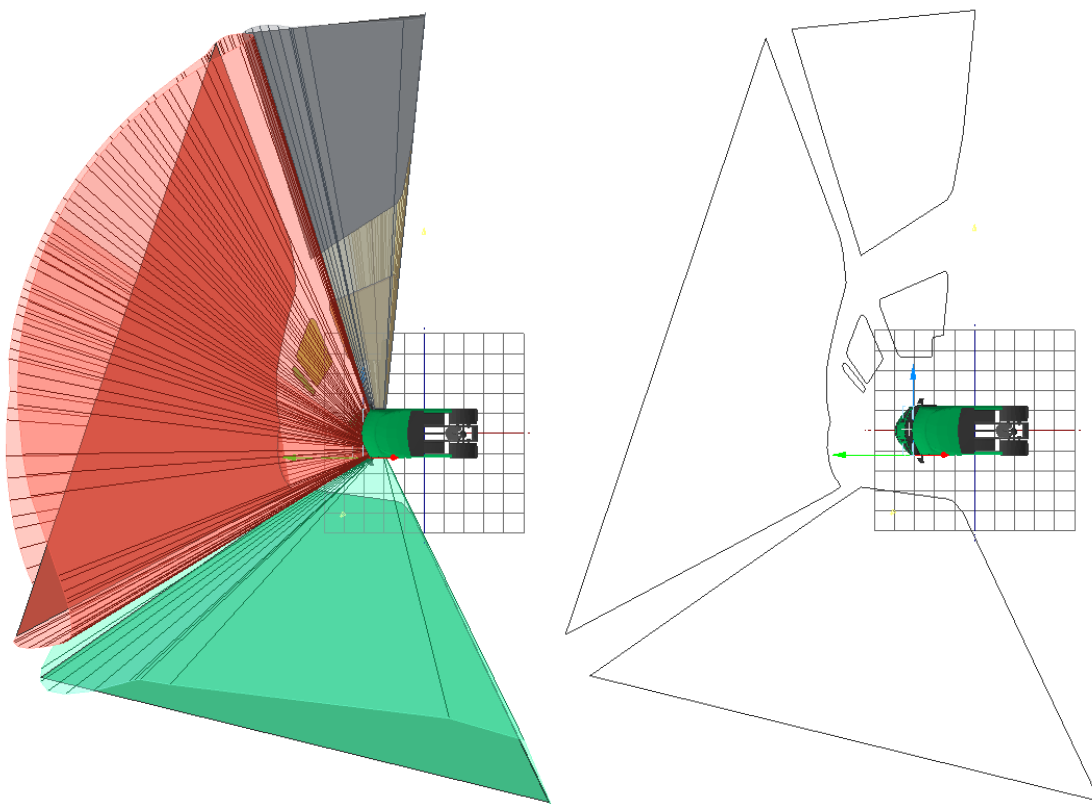

Figure 73. Ground plane FOV projections

Figure 74, Figure 75 and Figure 76 illustrate that the projections are conical in shape, projecting from the driver's eye point through the window aperture and beyond. Due to this conical nature some areas close to the vehicle are not visible. Anything inside the conical projection would be visible to the driver, anything not inside the projection would not be visible without the driver moving or through indirect vision such as a mirror.

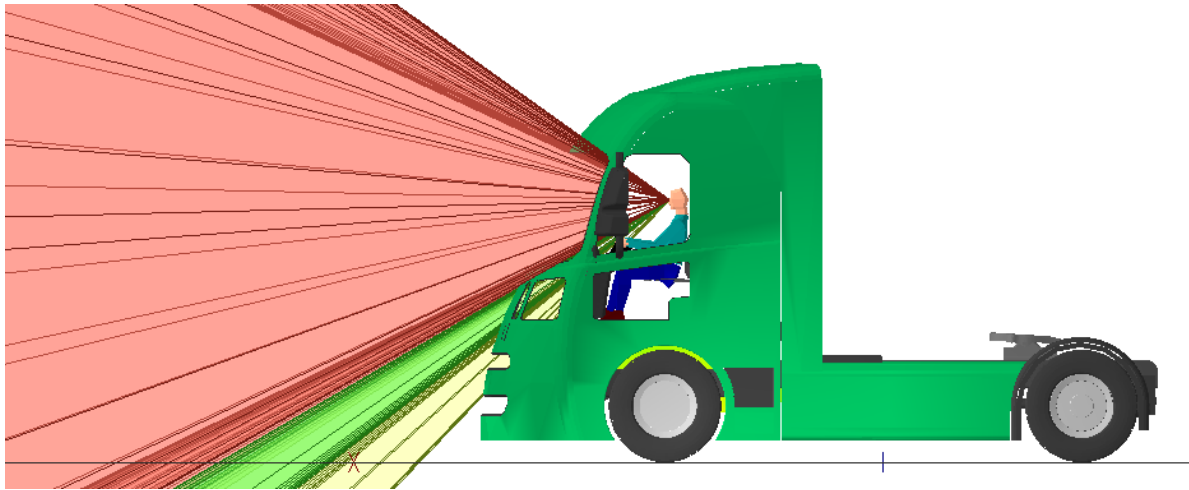

Figure 74. FOV projections to the front of the vehicle

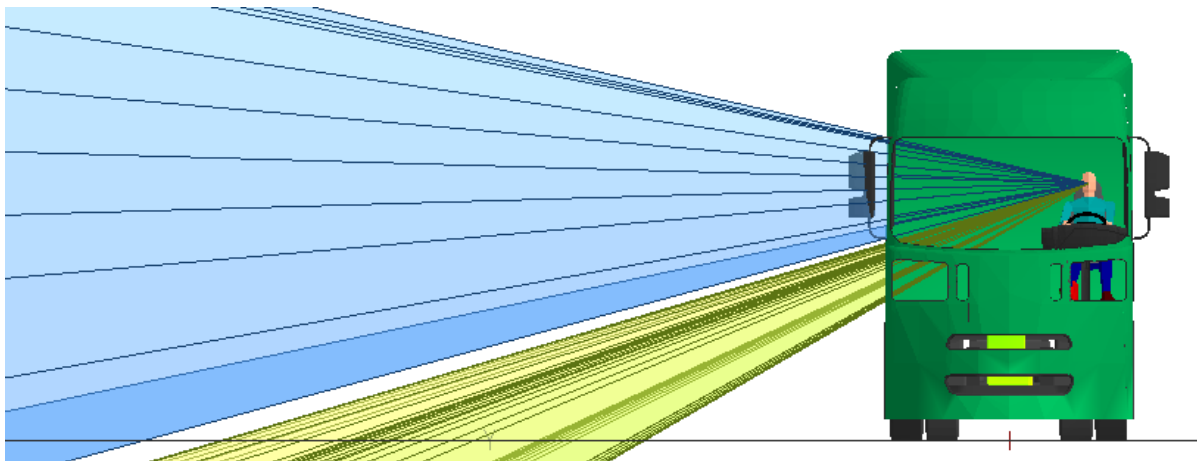

Figure 75. FOV projections to the right of the vehicle

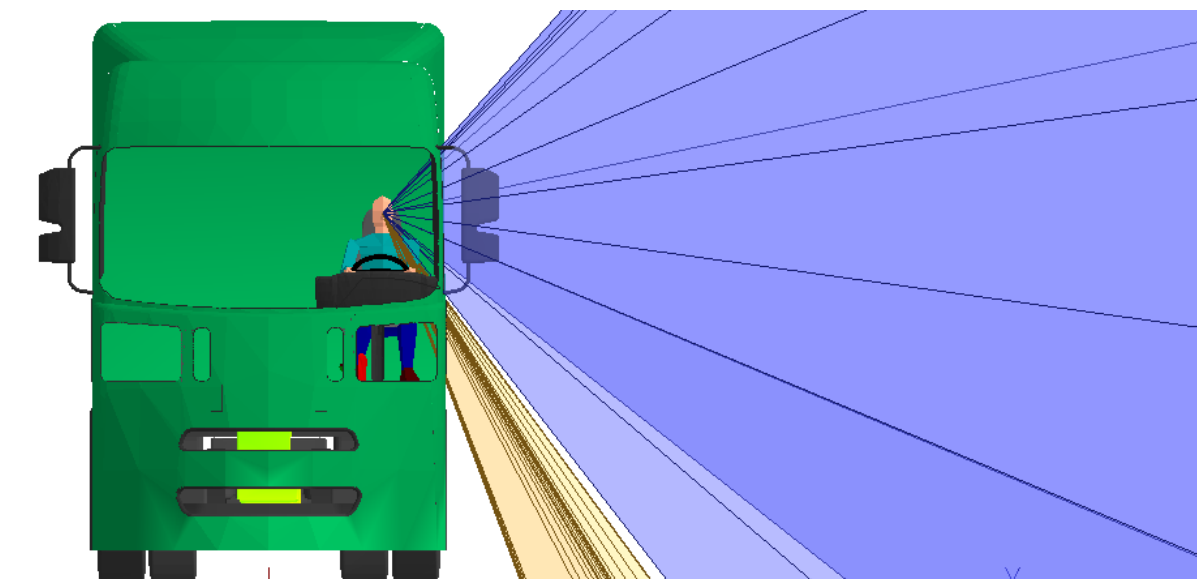

Figure 76. FOV projections to the left of the vehicle

### 3.2.3.2 FORWARD VISIBILITY – PEDESTRIAN

Figure 77 shows the visible areas in proximity to the cab taken at a height equivalent to the stature of a 50<sup>th</sup> %ile UK male (1755mm). The intersection of the projections and this plane are shaded green.

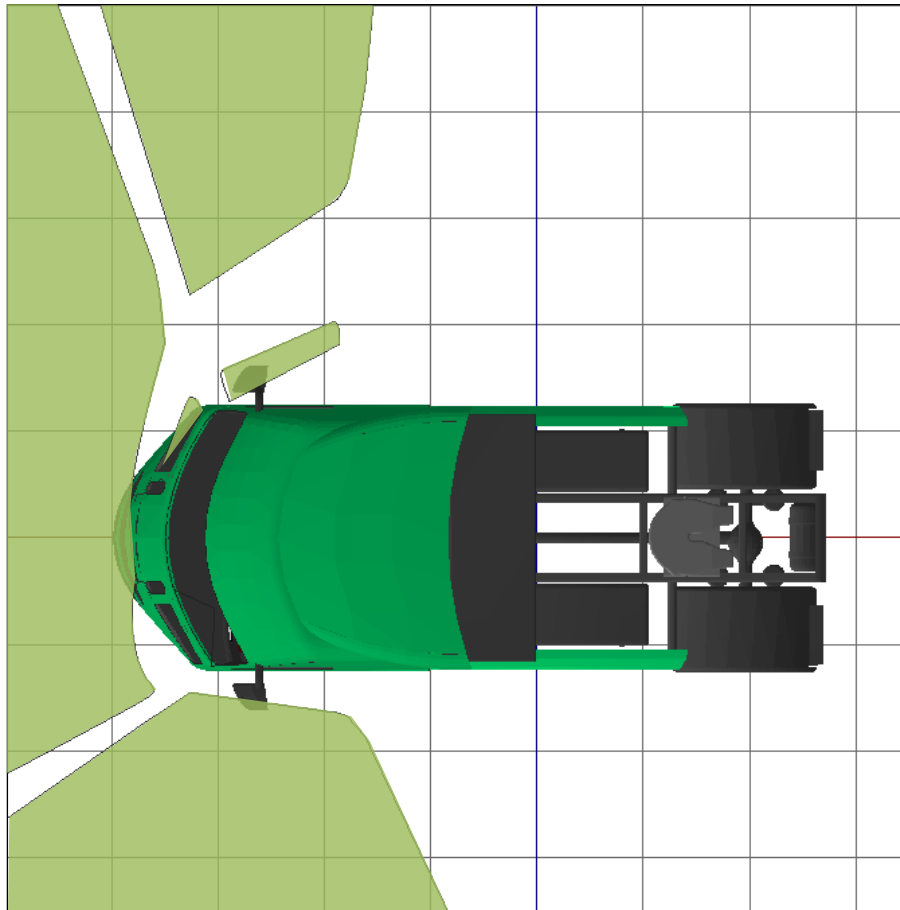

Figure 77. Ground plane +1755mm FOV projections

From the figure it is clear that the visible areas at a height representative of a pedestrian are closer to the vehicle than those taken at ground level shown in Figure 73. In addition Figure 78, Figure 79 and Figure 80 show that the blind spot to the front of the vehicle is significantly reduced. The revised dashboard design has increased visibility directly to the front by maximising visibility through the windscreen which has a lower bottom edge than the baseline DAF XF.

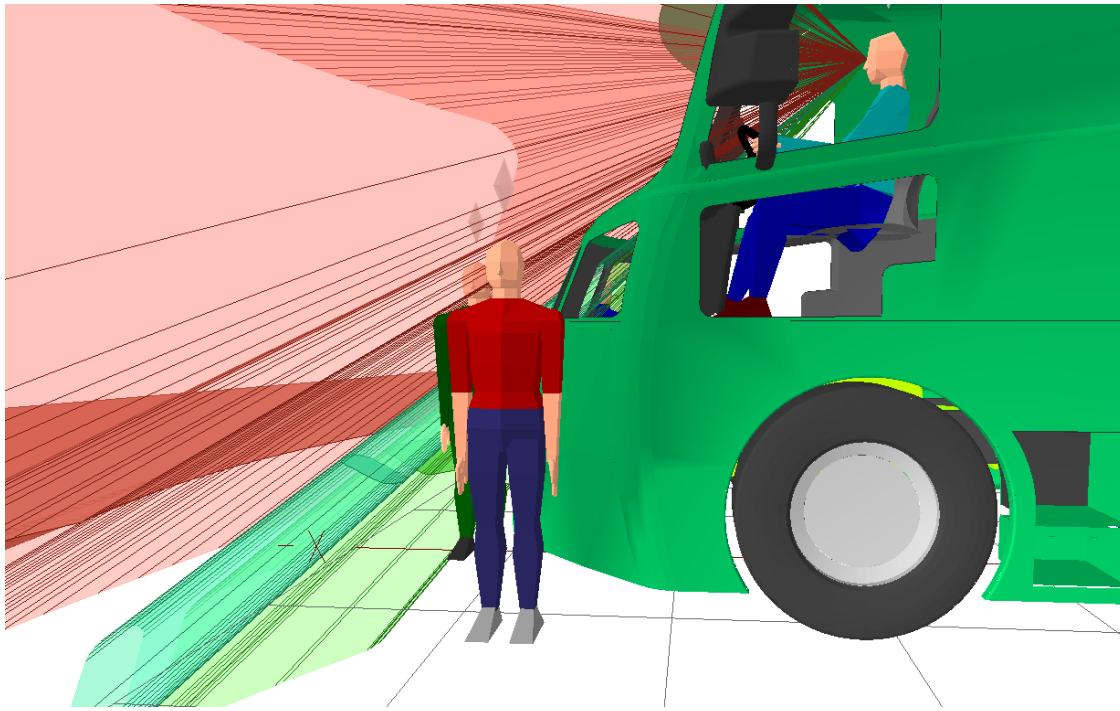

Figure 78. 3D view of the pedestrians positioned to the front of the vehicle



Figure 79. Driver's view of the pedestrians positioned to the front of the vehicle, the central (green) and right (blue) pedestrians are visible

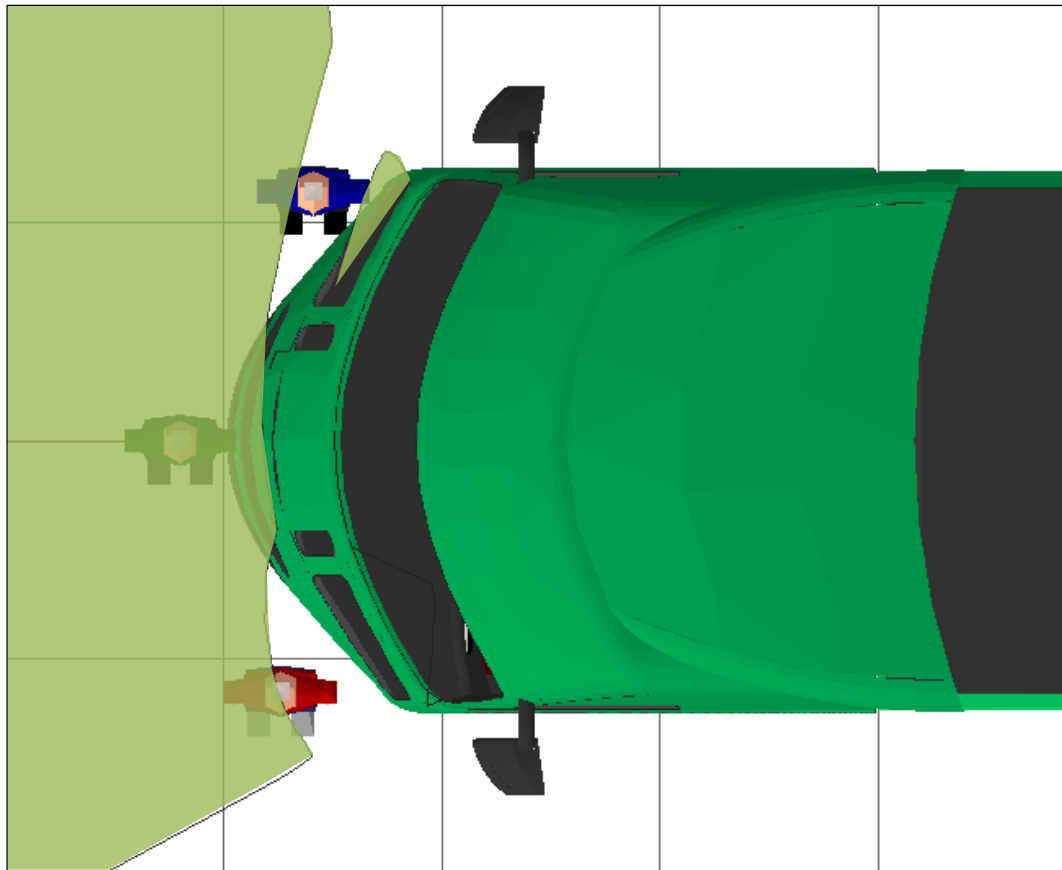

Figure 80. 2D plan view of the pedestrians positioned to the front of the vehicle overlaid with the visibility at the ground plane +1755mm

For forwards visibility of the pedestrian targets, the central (green) pedestrian and the right (blue) pedestrian are always visible, the left (red) pedestrian can be hidden from the driver's view. The red pedestrian is positioned at 141mm from the front of the vehicle, beyond which he would be visible.

### 3.2.3.3 FORWARD VISIBILITY – CYCLIST

Figure 81 shows the visible areas in proximity to the cab taken at a height equivalent to the stature of a 50<sup>th</sup> %ile UK male cyclist (1738mm). The intersection of the projections and this plane are shaded green.

Figure 82 and Figure 84 show that it is not possible for the cyclist visual targets to the front of the cab to be hidden from the driver's view. The three cyclists shown are all effectively touching the front of the vehicle and as shown in Figure 83 all three can be clearly seen. They would therefore be visible if they moved further forward as would be expected in a real world scenario. Figure 83 also shows the potential benefit of the lower glazed panels.

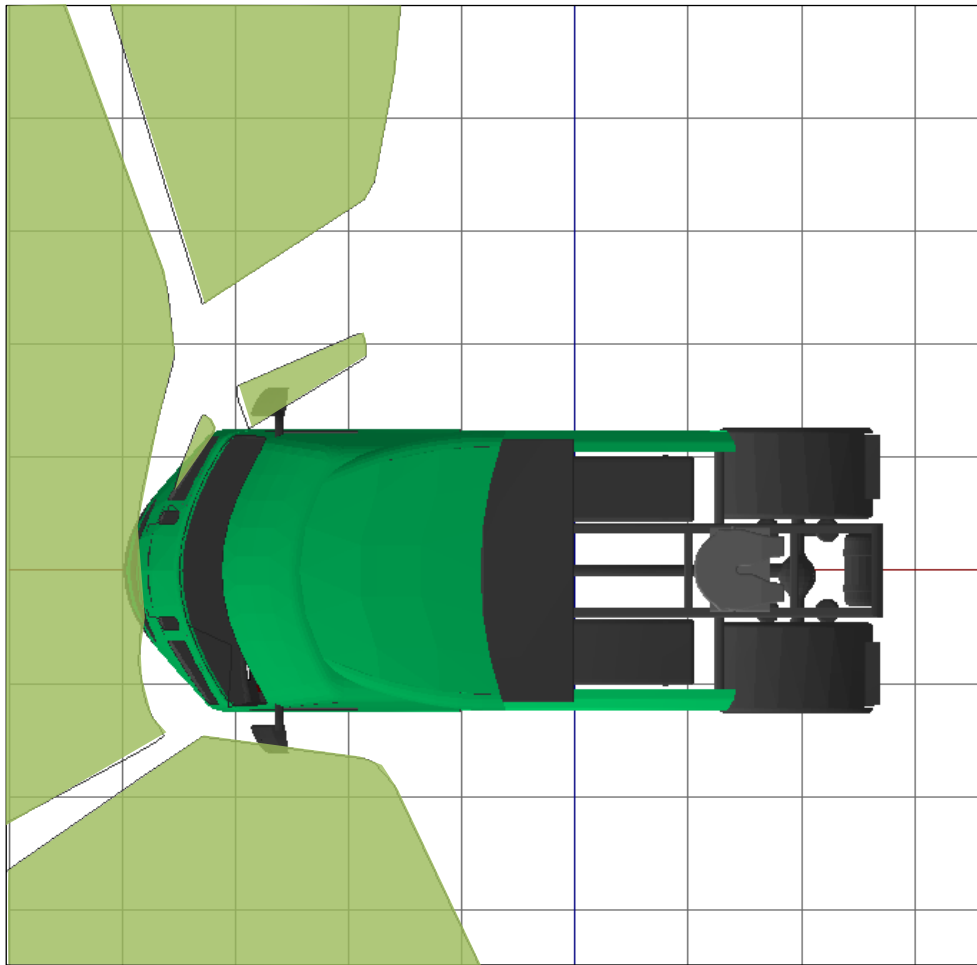

Figure 81. Ground plane +1738mm FOV projections

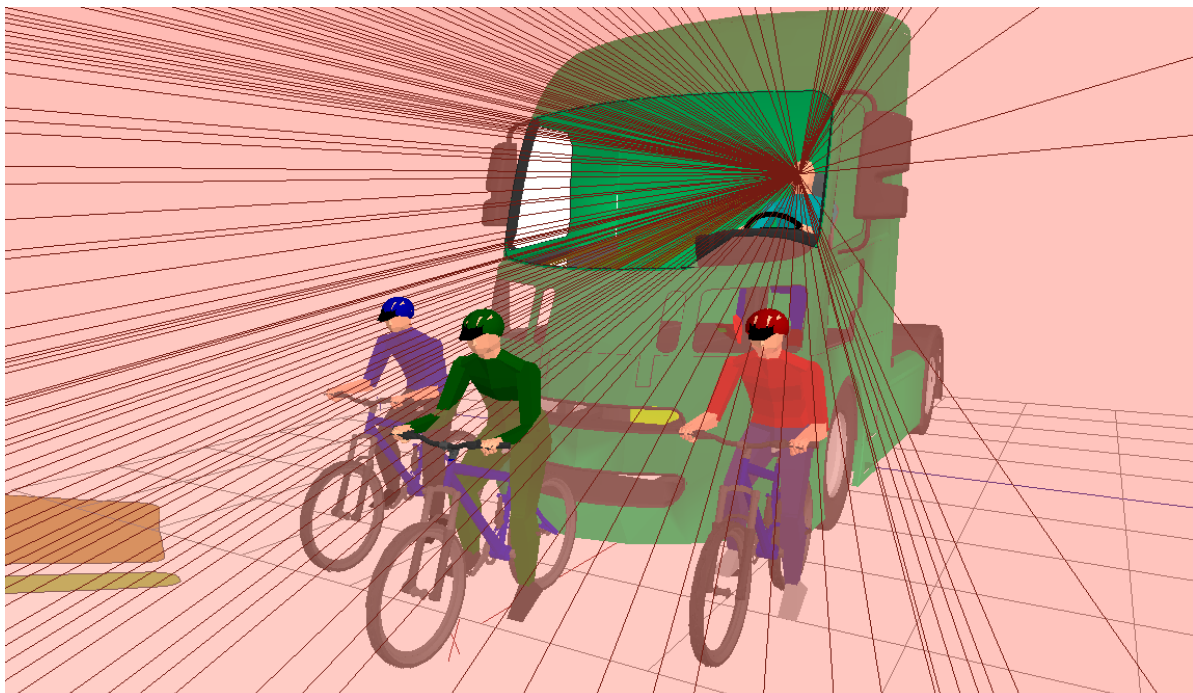

Figure 82. 3D view of the cyclists positioned to the front of the vehicle, showing how the heads of each cyclist is visible to the driver

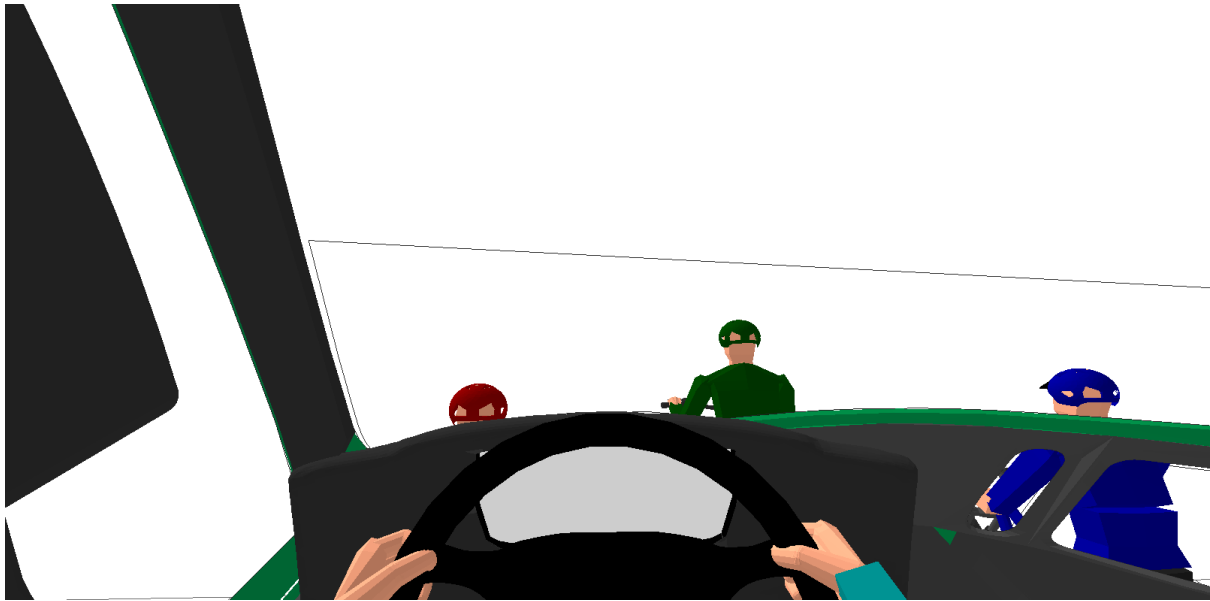

Figure 83. Driver's view of the cyclists positioned to the front of the vehicle, all cyclists are visible

If Figure 55 is compared to Figure 83, the benefits of the reduced dashboard structure in concept iteration 2 can be clearly seen in that it allows the lower windscreen design to be utilised for direct vision.

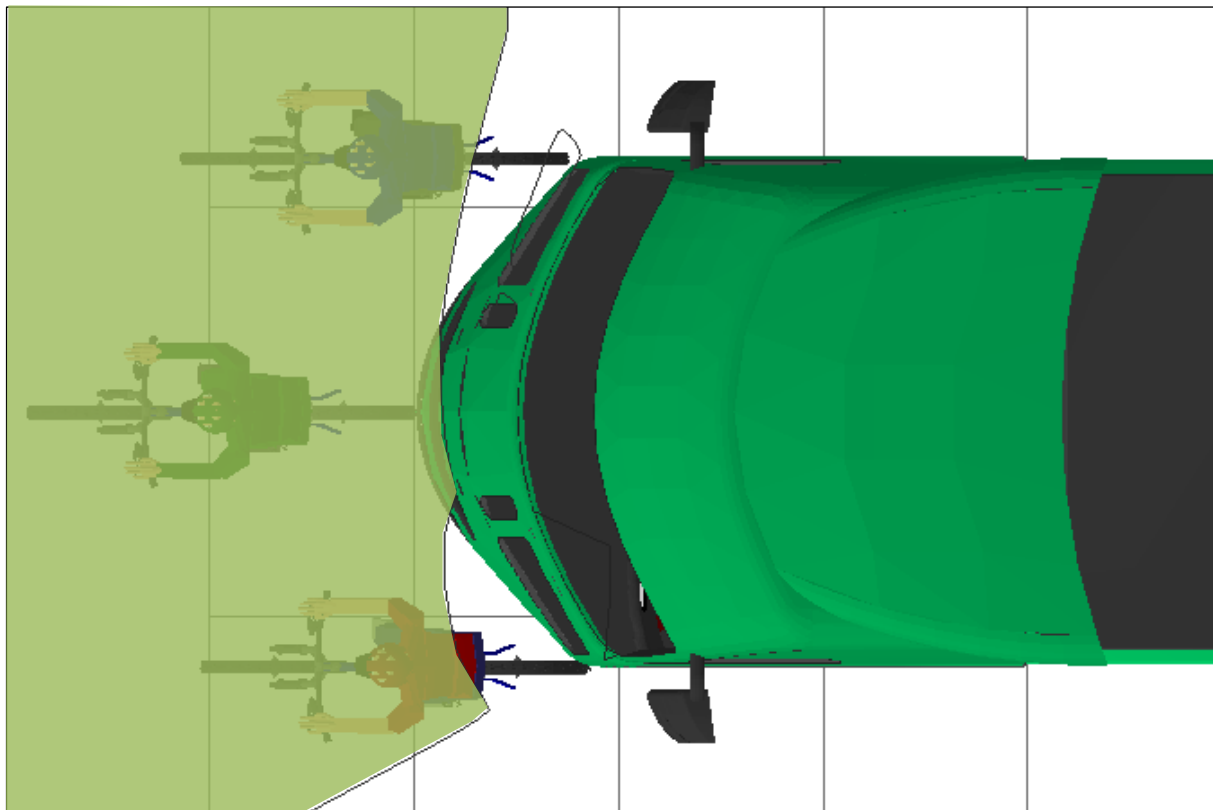

Figure 84. 2D plan view of the cyclists positioned to the front of the vehicle overlaid with the visibility at the ground plane +1738mm

For forwards visibility of the cyclist targets, all of the cyclists are visible to the driver.

### 3.2.3.4 OFFSIDE (DRIVER SIDE) VISIBILITY – CYCLIST

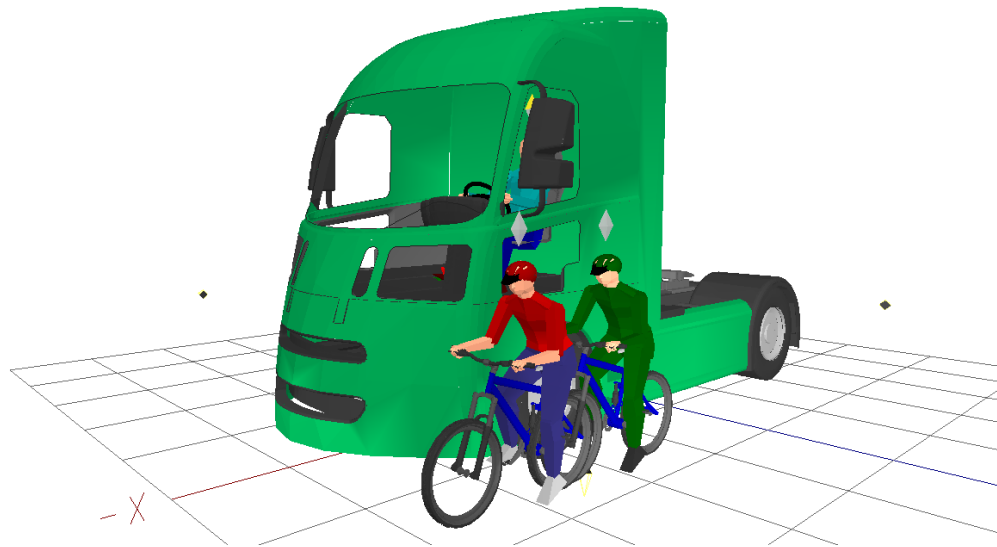

Figure 85. 3D view of cyclists positioned to the offside of the vehicle

Visibility to the driver's side of the vehicle, though the side windows is shown in Figure 86, Figure 87 and Figure 88. The projections show that there is no blind spot to the driver's side of the vehicle that could obscure a cyclist. Figure 87 shows that even with the cyclist touching the side of the cab they would still be visible to the driver, with the lower door window providing additional direct vision for smaller visual targets than those used in the analysis.

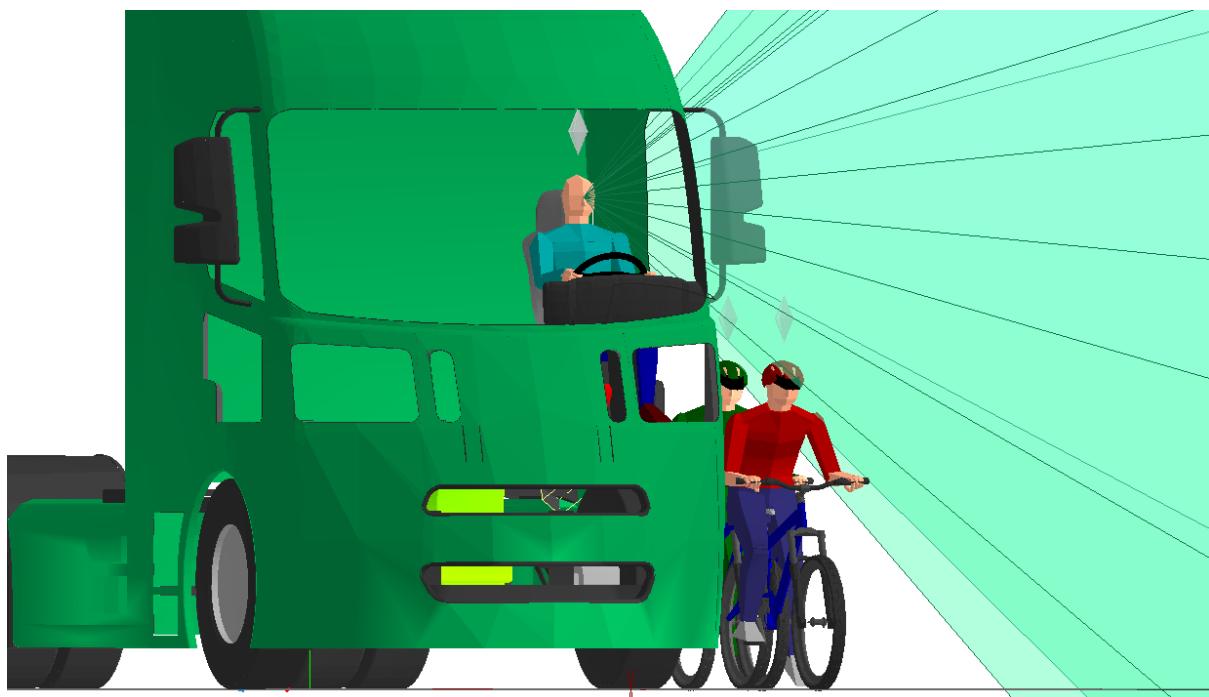

Figure 86. 3D view of cyclists positioned to the offside of the vehicle



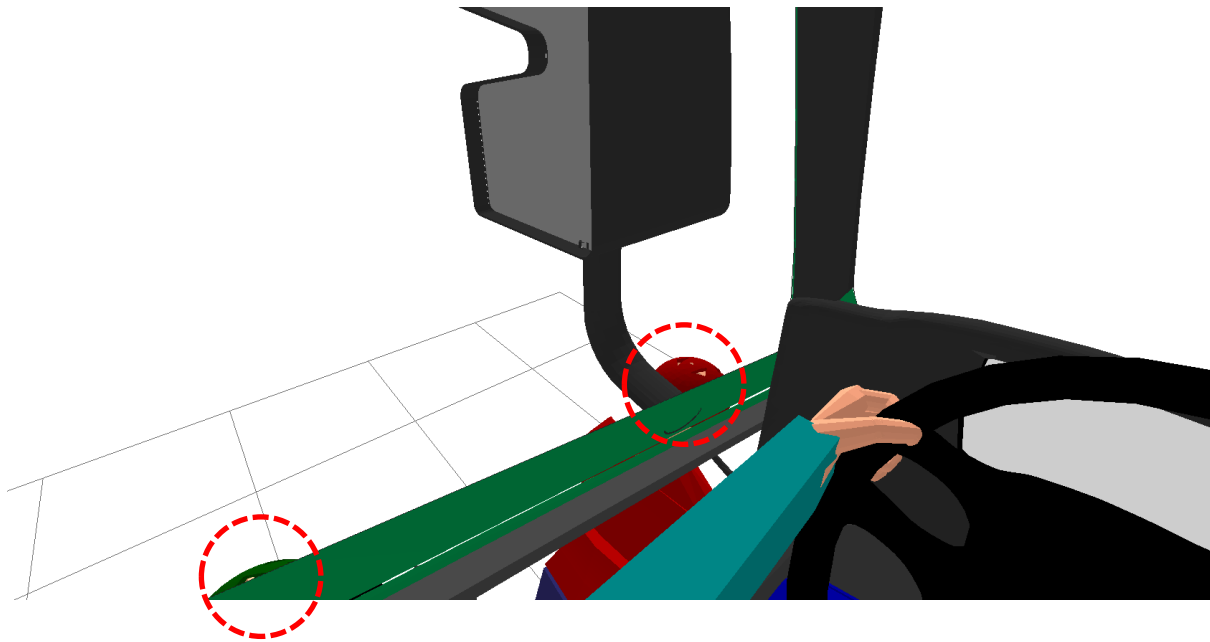

Figure 87. Driver's view of the cyclists positioned to the offside of the vehicle, the rear (green) and front (red) cyclists are visible

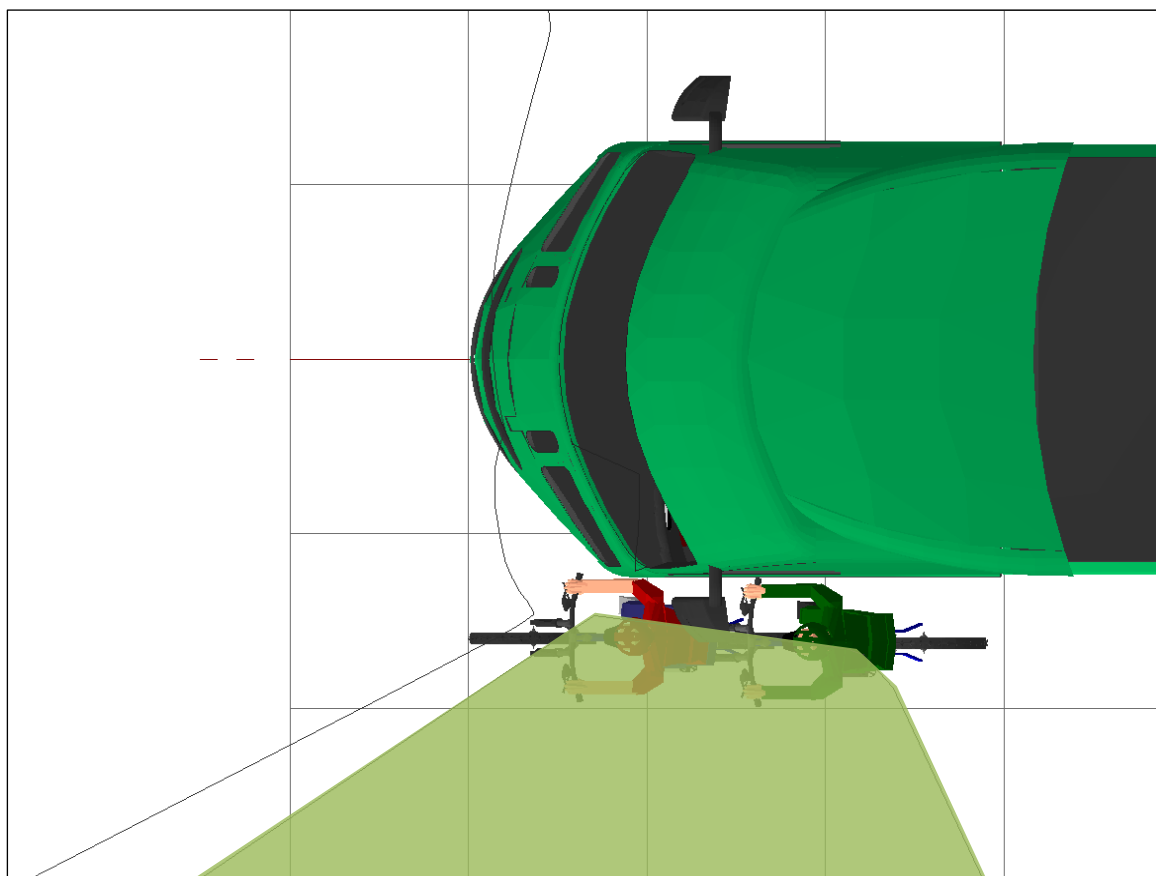

Figure 88. 2D plan view of the cyclists positioned to the offside of the vehicle overlaid with the visibility at the ground plane +1738mm

For offside visibility of the cyclist targets, both the rear (green) cyclist and the front (red) cyclist are always visible.

### 3.2.3.5 OFFSIDE (DRIVER SIDE) VISIBILITY – VW GOLF

Figure 89 shows the visible areas in proximity to the cab taken at the height of a 2010 Volkswagen golf (1450mm). The intersection of the projections and this plane are shaded green. The additional field of view afforded by the lower glazed panels in the front of the cab and in the lower section of the door are particularly apparent in filling the blind spot to the nearside (passenger side) of the vehicle.

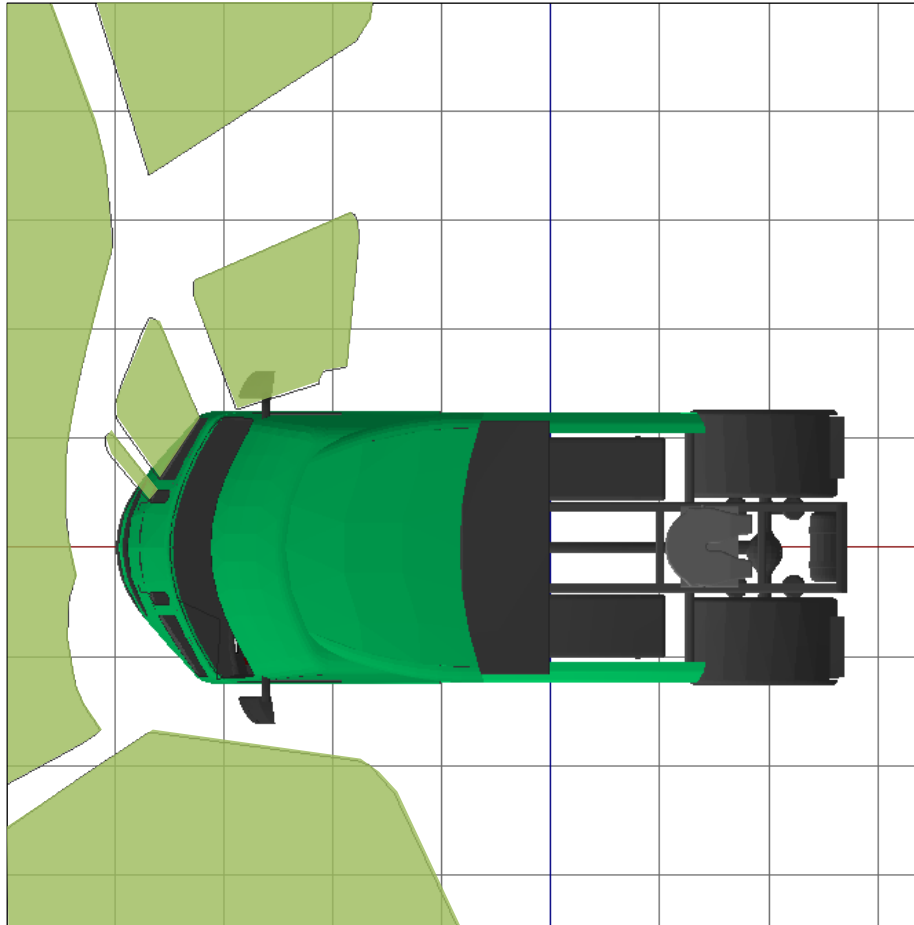

Figure 89. Ground plane +1450mm FOV projections

Figure 90, Figure 91, Figure 92 and Figure 93 show the visibility to the driver's side of the vehicle with the Volkswagen Golf visual target. In this instance the car is always visible to driver through the side windows.

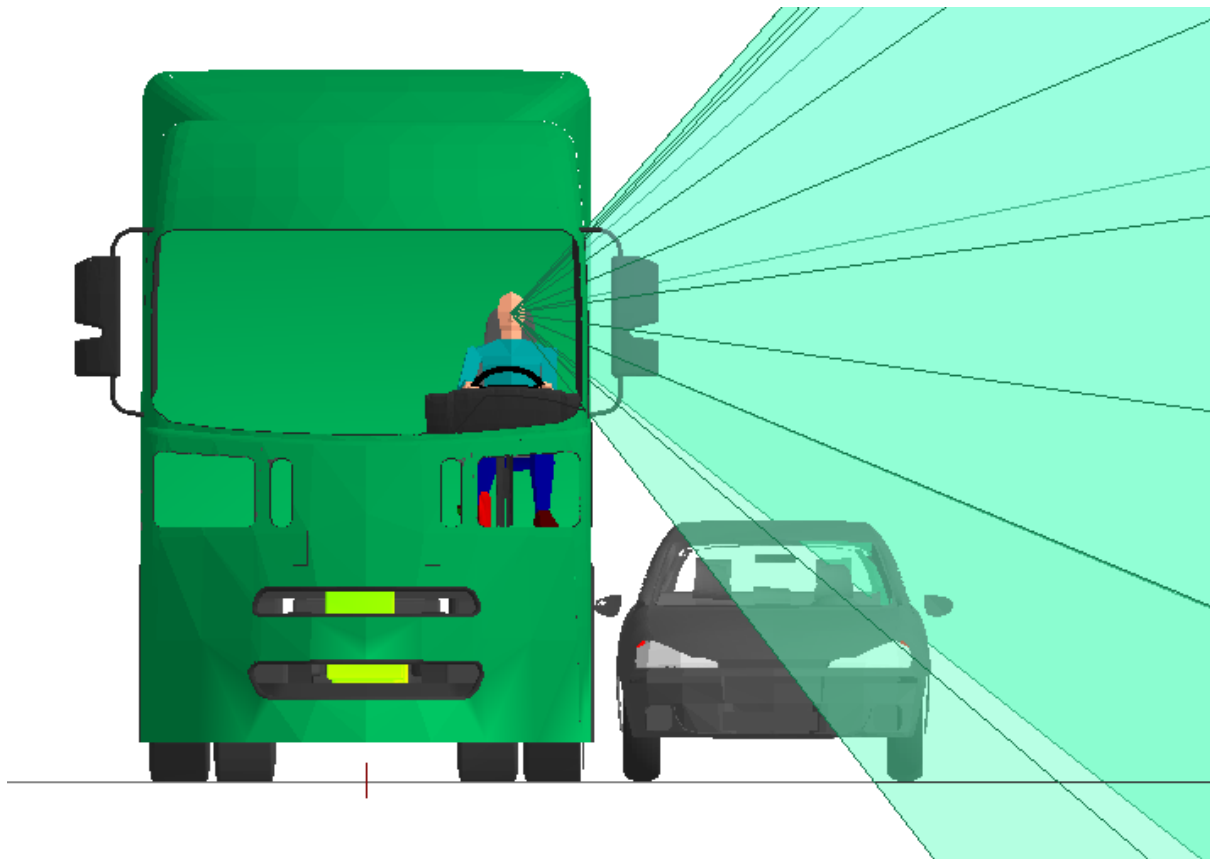

Figure 90. 3D view of the Volkswagen Golf positioned to the offside of the vehicle

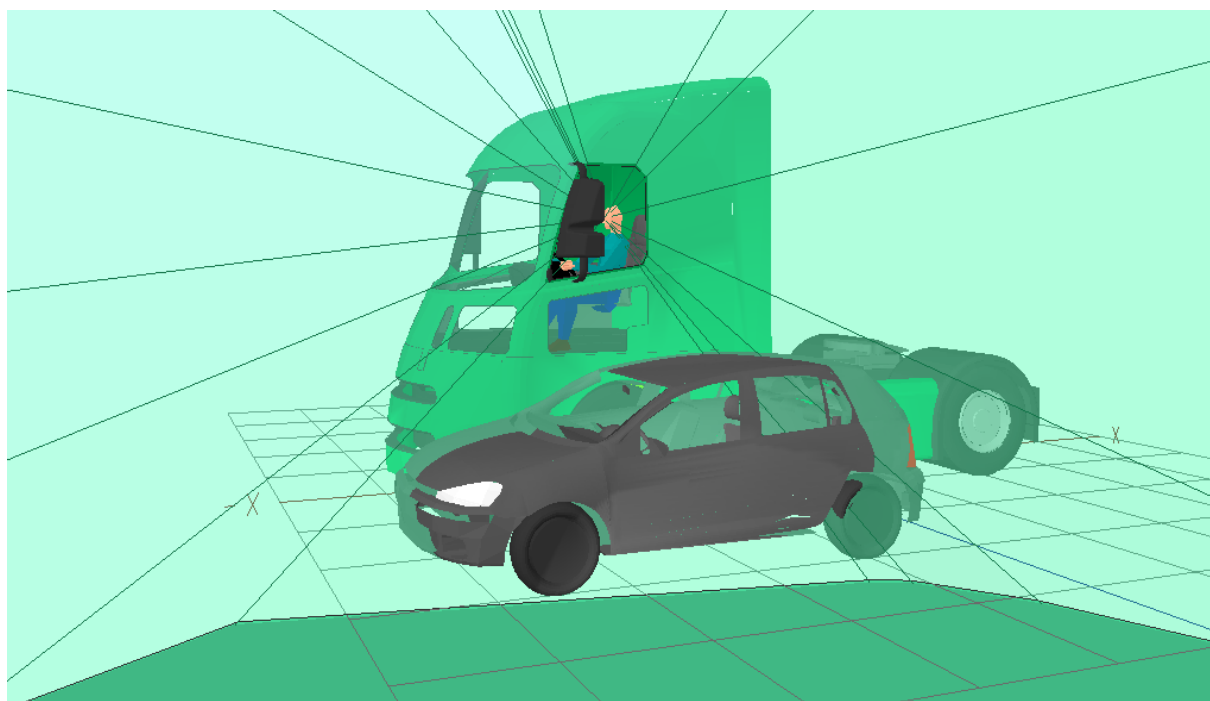

Figure 91. 3D view of the Volkswagen Golf positioned to the offside of the vehicle, clearly showing the amount of the vehicle that would be visible

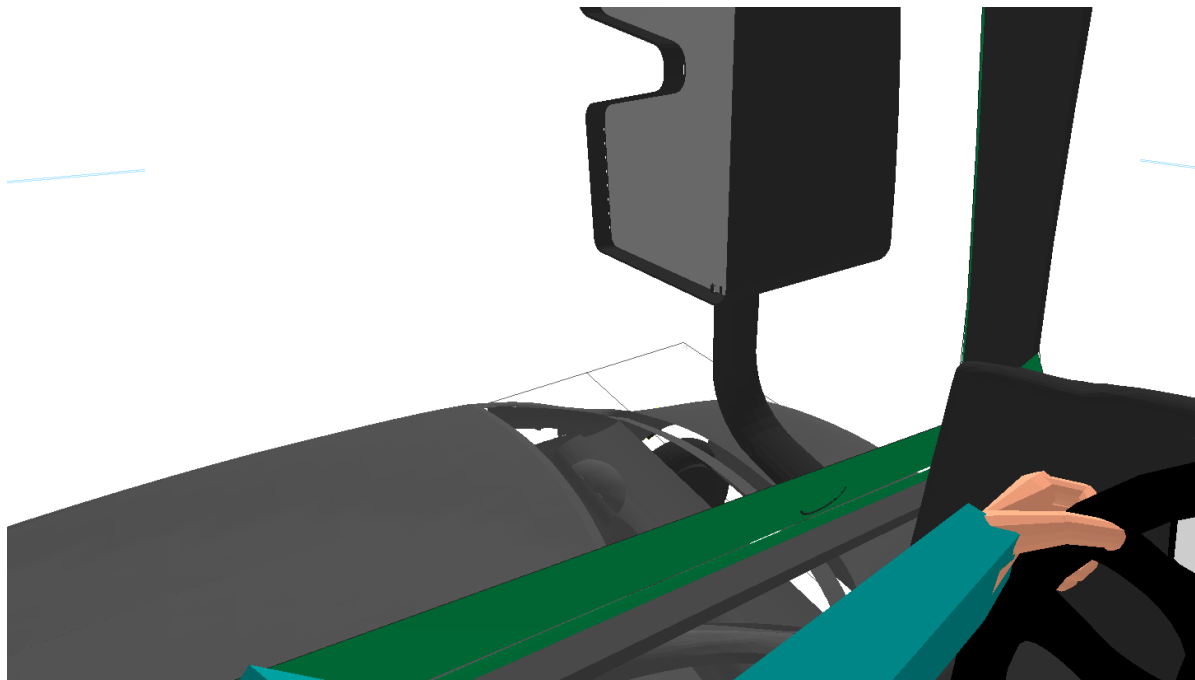

Figure 92. Driver's view of the Volkswagen Golf positioned to the offside of the vehicle, clearly showing the amount of the vehicle that would be visible

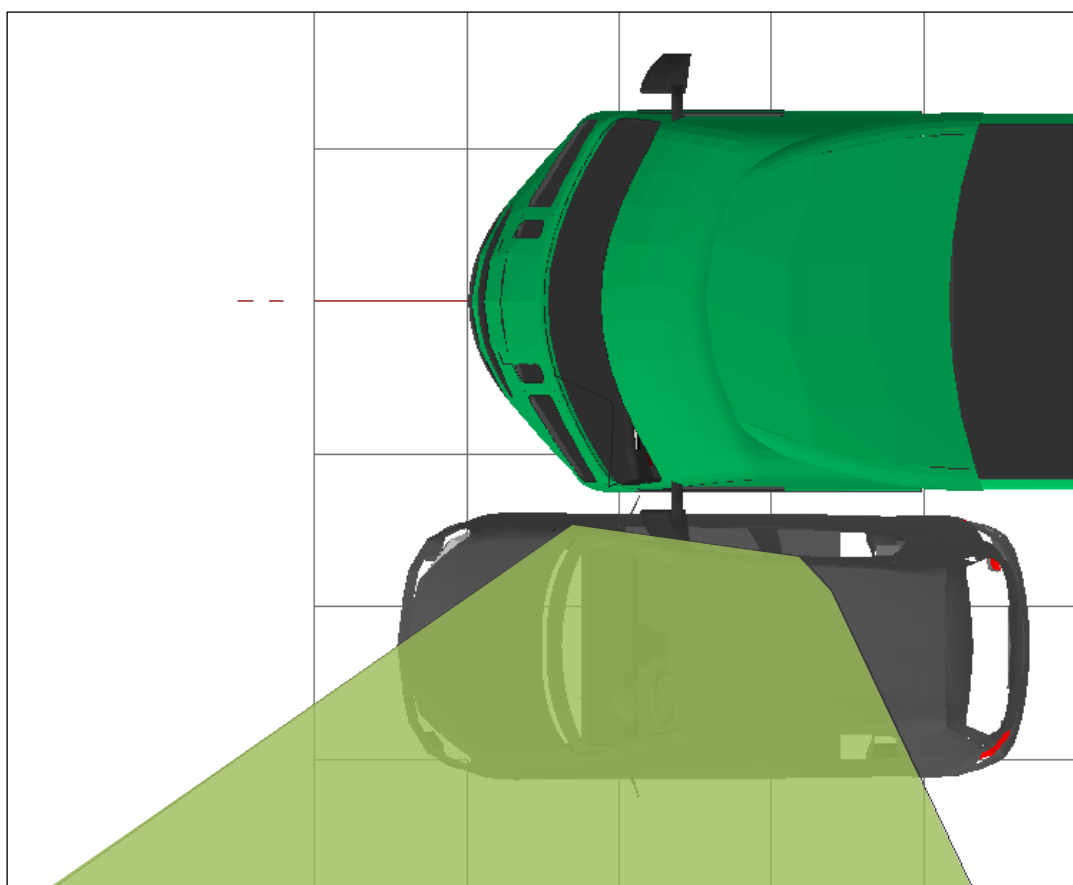

Figure 93. 2D plan view of the Volkswagen Golf positioned to the offside of the vehicle overlaid with the visibility at the ground plane +1450mm

For offside visibility of the car, the target is always visible.

### 3.2.3.6 NEARSIDE (PASSENGER SIDE) VISIBILITY – CYCLIST

With the cyclist visual target positioned to the passenger side the blind spot in which the visual target can be hidden for the previously assessed vehicles is removed. Figure 95 shows that the cyclist visual target may not be visible through the passenger window but instead can be seen through the panel in the lower part of the passenger door.

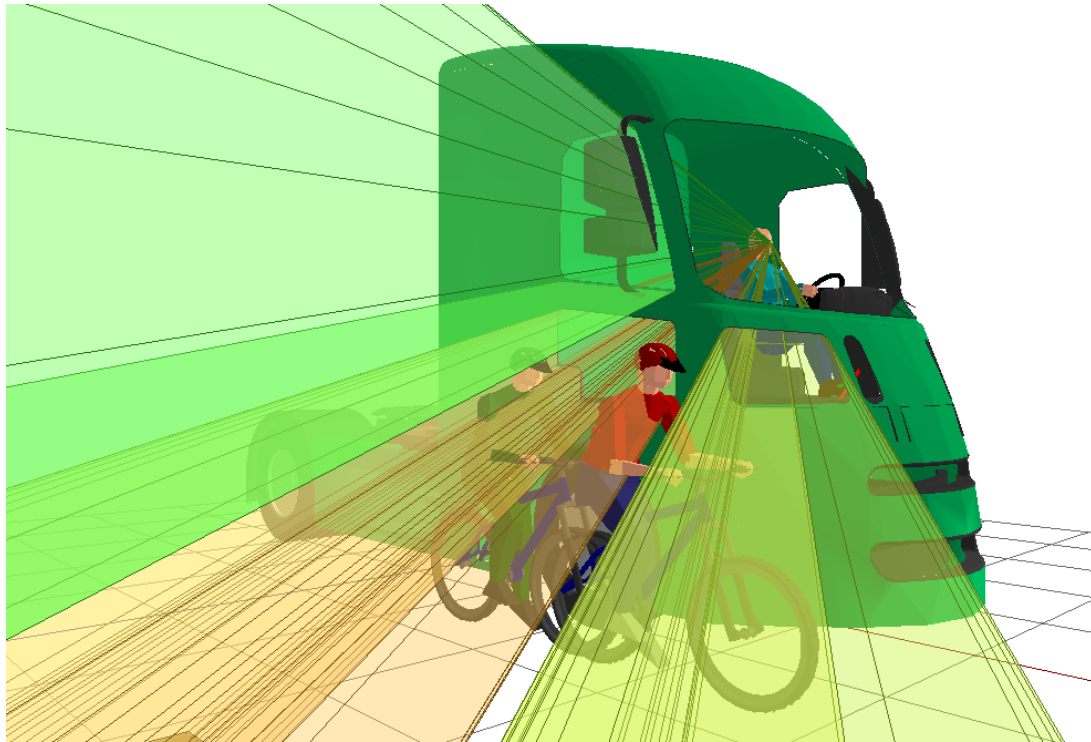

Figure 94. 3D view of the cyclists positioned to the nearside of the vehicle



Figure 95. Driver's view of the cyclists positioned to the nearside of the vehicle, the rear (green) and front (red) cyclists are both clearly visible through the lower door windows

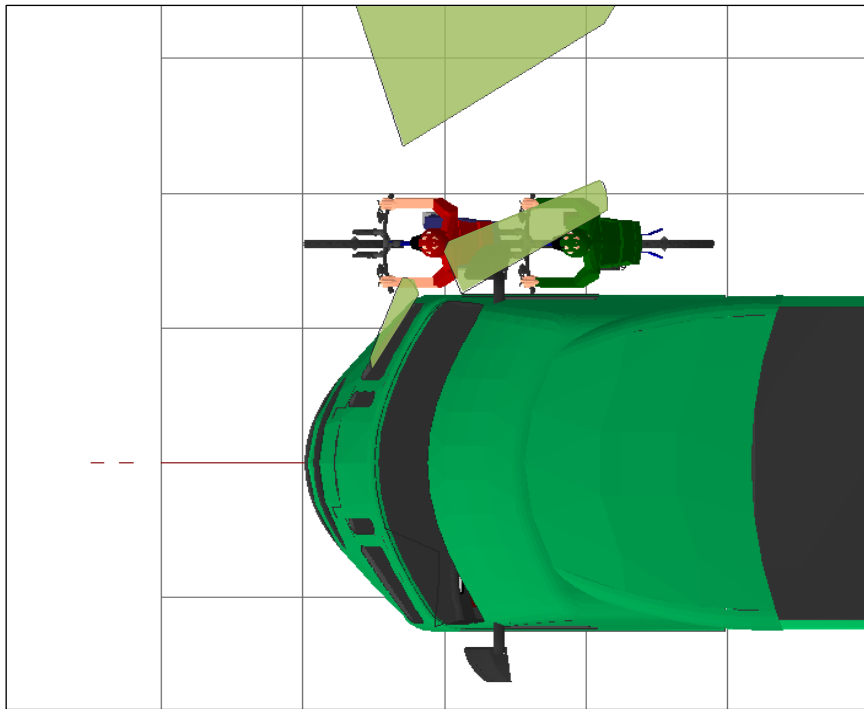

Figure 96. 2D plan view of the cyclists positioned to the nearside of the vehicle overlaid with the visibility at the ground plane +1738mm

For nearside visibility of the cyclist targets, both the rear cyclist (green) and the front cyclist (red) are visible to the driver.

### 3.2.3.7 NEARSIDE (PASSENGER SIDE) VISIBILITY – VW GOLF

Figure 97, Figure 98, Figure 99 and Figure 100 show the visibility to the passenger side of the vehicle with the Volkswagen Golf visual target. As with the cyclist visual target the blind spot to this side of the vehicle is mitigated through the lower glazed panel in the door.

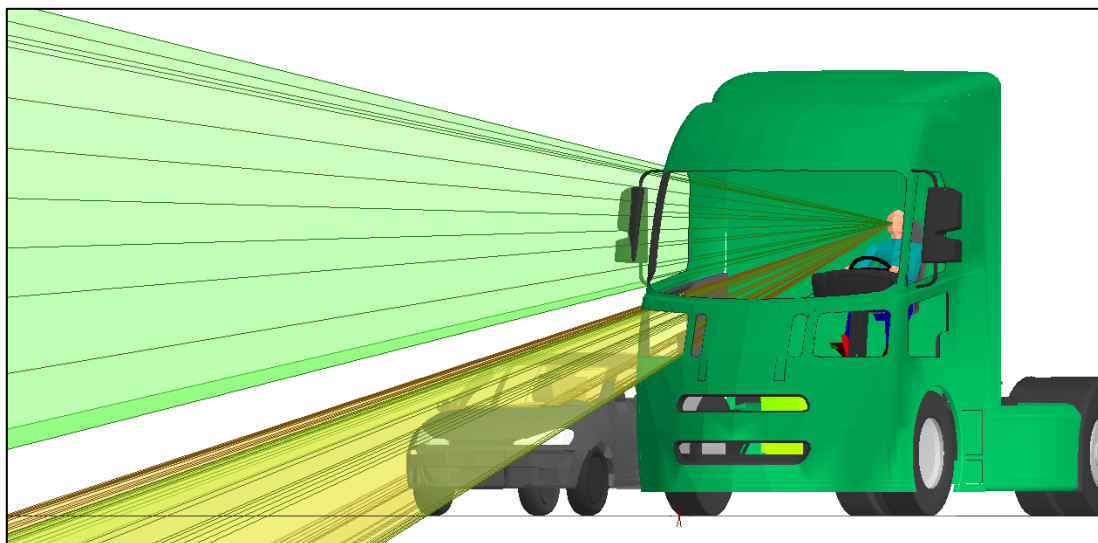

Figure 97. 3D view of the Volkswagen Golf positioned to the nearside of the vehicle

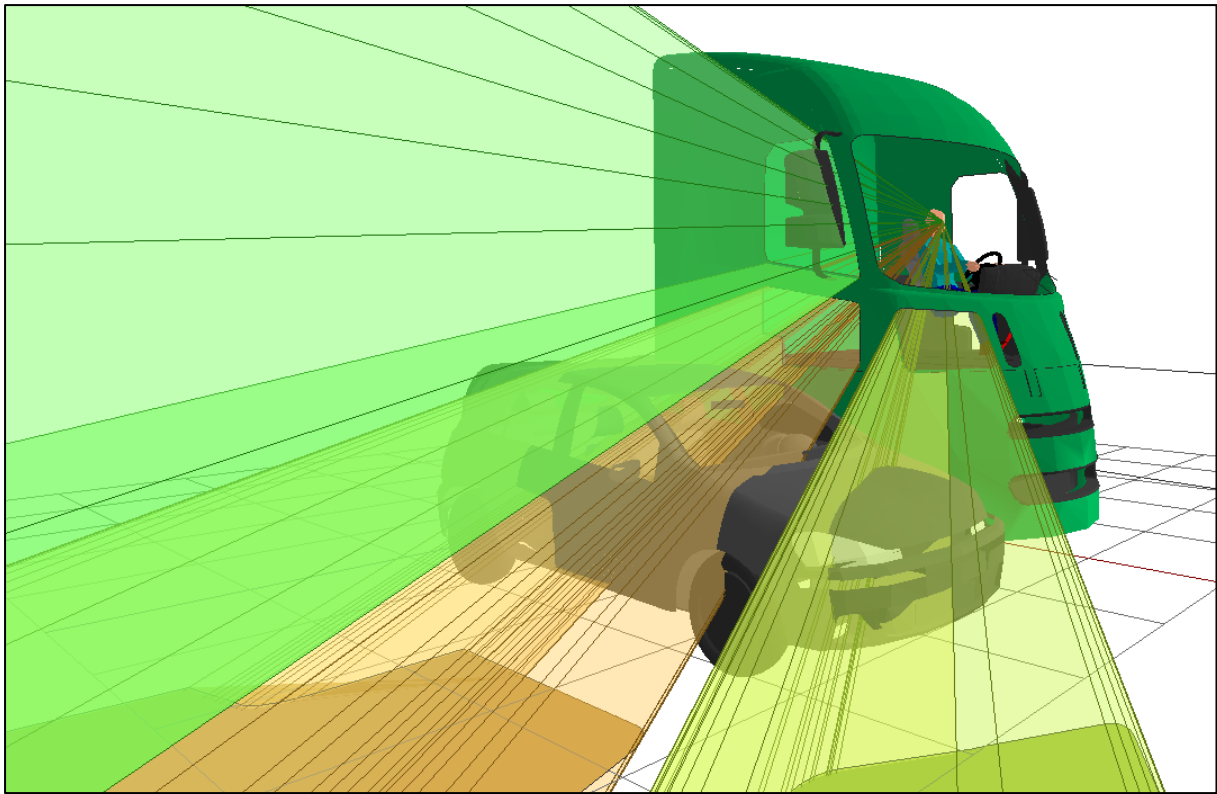

Figure 98. 3D view of the Volkswagen Golf positioned to the nearside of the vehicle



Figure 99. Driver's view of the Volkswagen Golf positioned to the nearside of the vehicle, the car is clearly visible through the lower door and right front windows

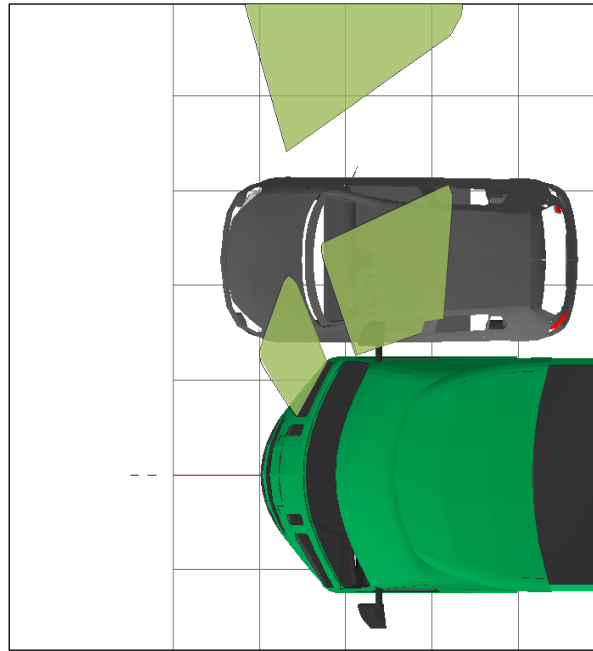

Figure 100. 2D plan view of the Volkswagen Golf positioned to the nearside of the vehicle overlaid with the visibility at the ground plane +1450mm

For nearside visibility of the car target, the car is always visible to the driver. Figure 101 shows the variability of the projections on the floor for the three driver eye positions that have been analysed. This shows that the lower glazed area in the passenger door is equally effective for all driver eye positions.

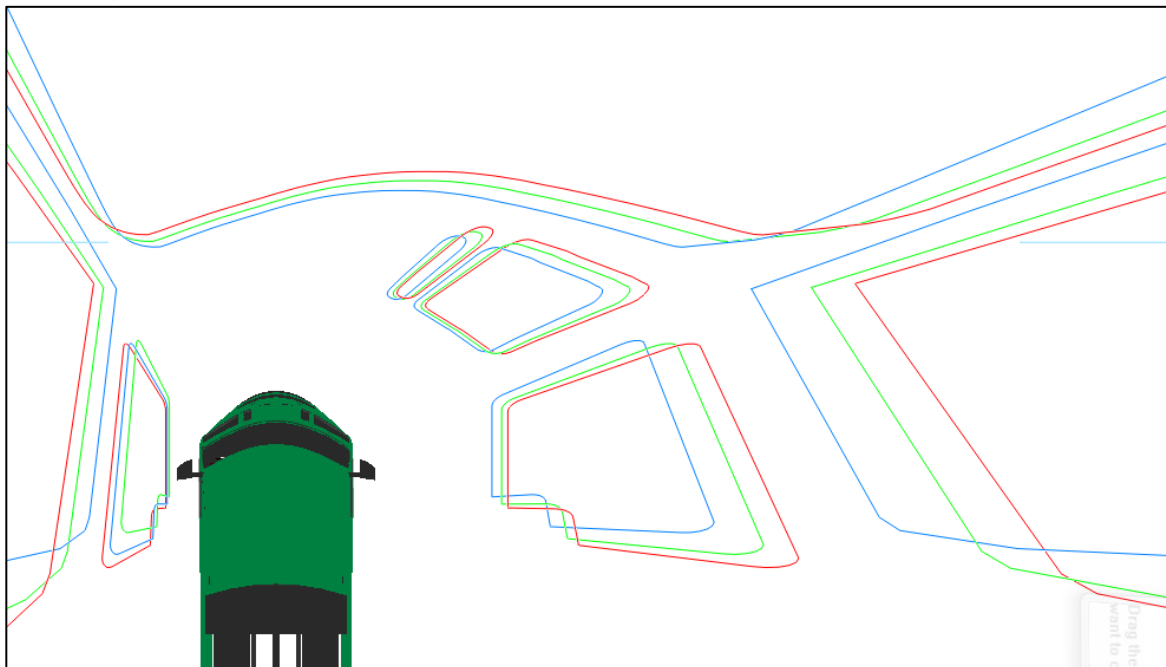

Figure 101. A plan view of the projection of the windscreen and side windows onto the floor for the FKA concept iteration 1 for a range of driver eye positions. Red=smallest driver, Green=average sized driver, and Blue=tallest driver



### 3.2.4 FKA CONCEPT ITERATION 2 - REDUCED CAB HEIGHT BY 230MM

The following sections show the evaluation of the FKA Concept Iteration 2.

#### 3.2.4.1 DIRECT VISION – APERTURE PROJECTIONS

The following projections illustrate the extent of direct vision afforded to the driver via windows or other apertures in the cab. Figure 102 shows a top-down view of all of the window projections for the FKA Concept Iteration 2 cab. The image on the right of Figure 102 shows the areas of these projections that intersect with the ground. The additional glazed area projections are visible to the nearside of the cab.

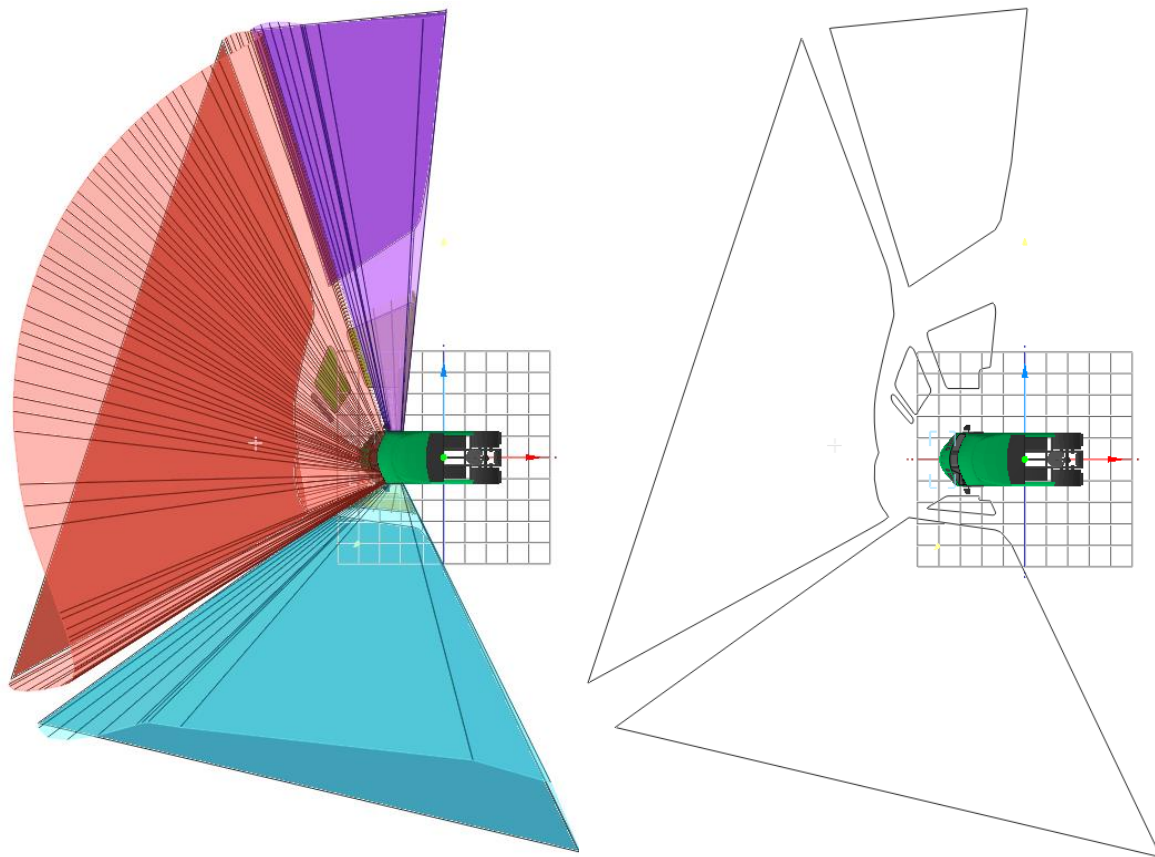
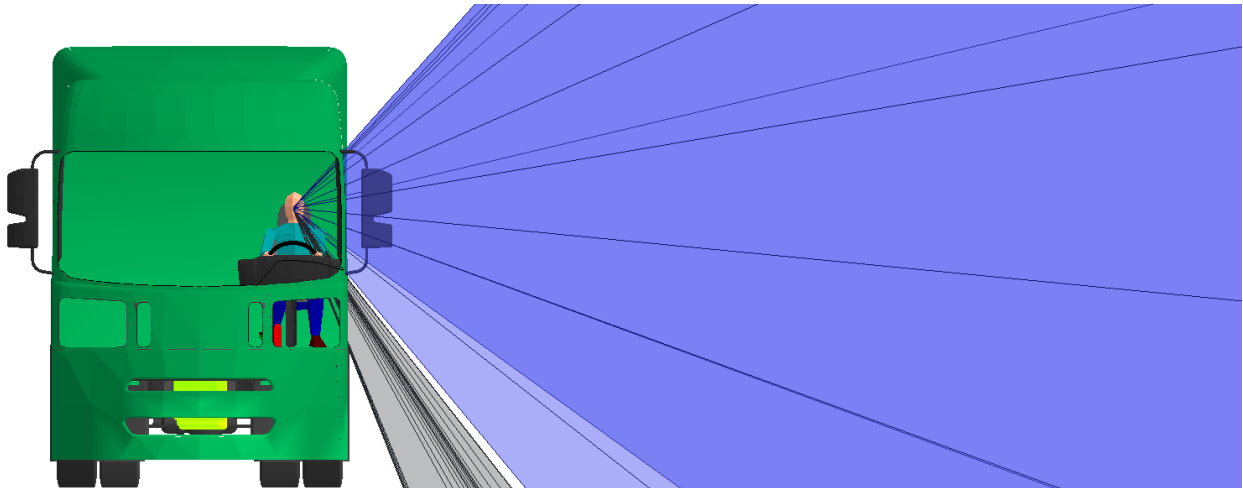

Figure 102. Plan view. The combined projections for the window apertures



and Figure 103 illustrate that the projections are conical in shape, projecting from the driver's eye point through the window aperture and beyond. Due to this conical nature some areas close to the vehicle are not visible. Anything inside the conical projection would be visible to the driver, anything not inside the projection would not be visible without the driver moving or through indirect vision such as a mirror.

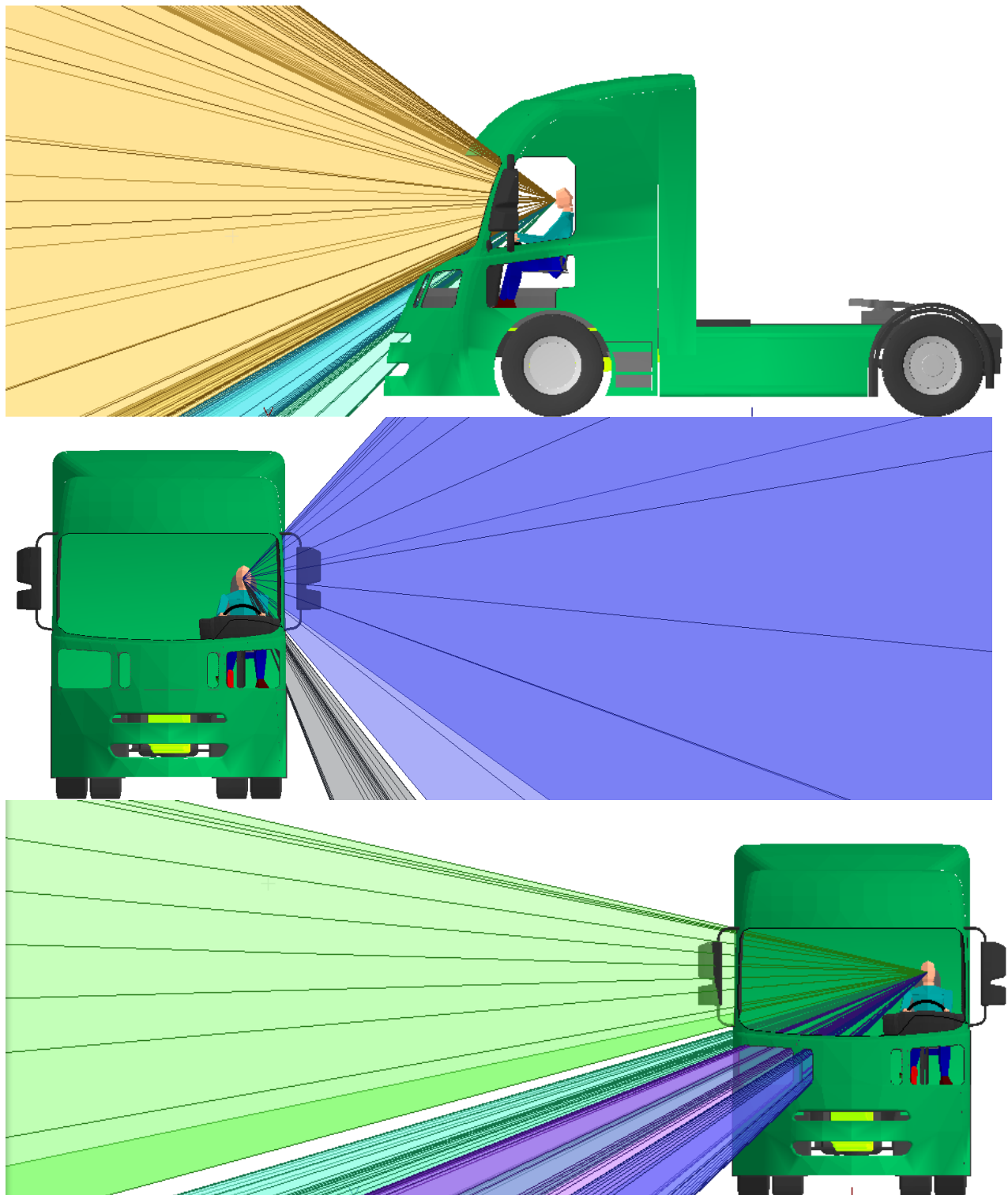
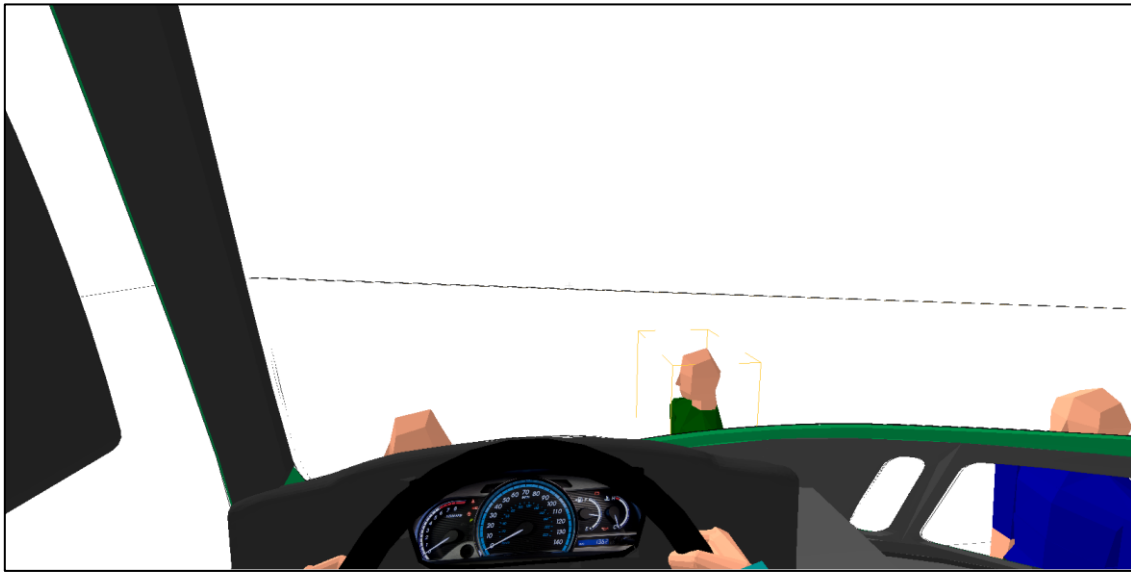

Figure 103. Frontal views of the near side and off side door window projections

#### 3.2.4.2 FORWARD VISIBILITY – PEDESTRIAN

Figure 104, Figure 105 and Figure 106 show that the blind spot to the front of the vehicle is significantly reduced. The benefit of lowering the cab over iteration 1 has resulted in all of the pedestrian visual targets being clearly visible to the driver. This

particular design would make it extremely difficult for a pedestrian to walk in front of the cab without being seen.



**Figure 104. Driver's eye view. All pedestrians can be seen by the driver through the windscreen, with additional visibility through the right hand lower windows**

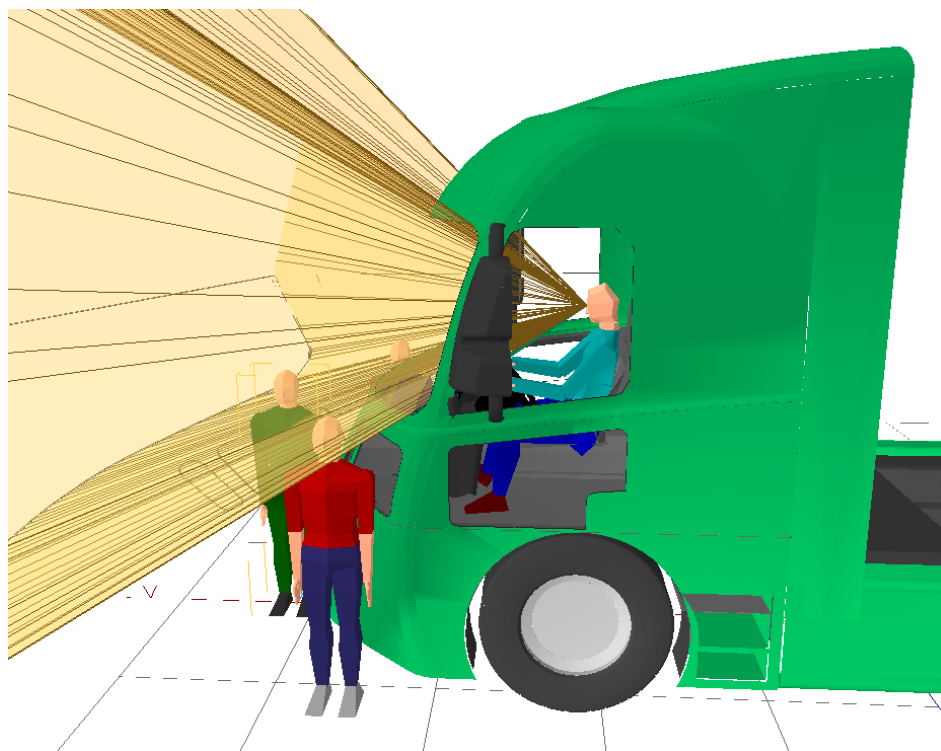

**Figure 105. Side view. All pedestrians are visible to the driver.**

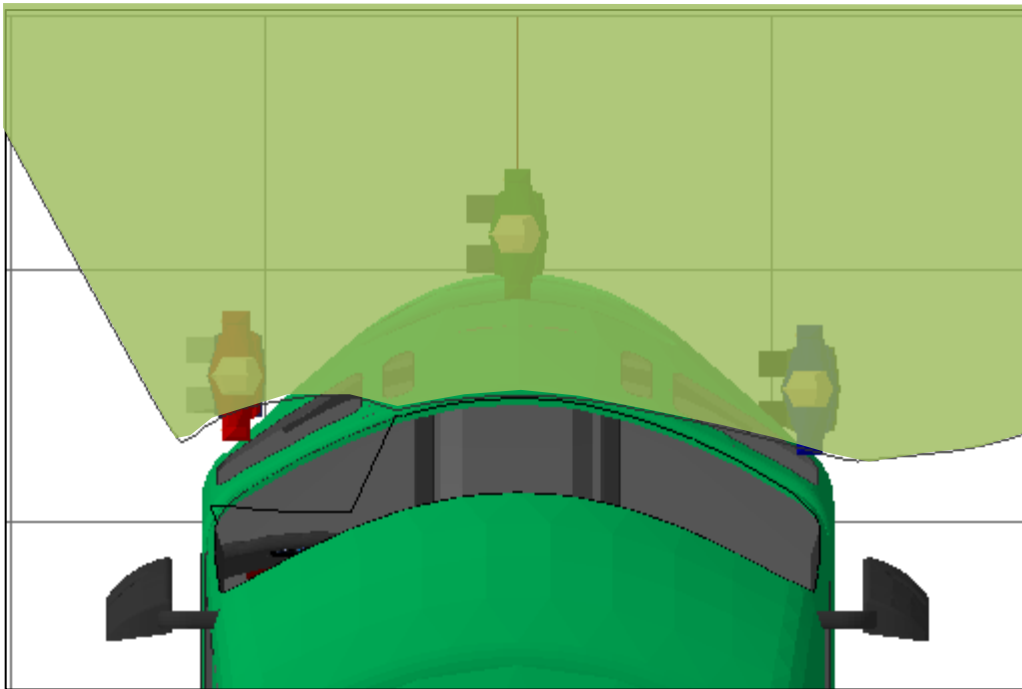

Figure 106. Plan view. All pedestrians are visible to the driver.

For forwards visibility of the pedestrian targets, all three are clearly visible.

#### 3.2.4.3 FORWARD VISIBILITY – CYCLIST

Figure 108 and Figure 109 show that it is not possible for the cyclist visual targets to the front of the cab to be hidden from the driver's view. The three cyclists shown are all effectively touching the front of the vehicle and as shown in Figure 107 all three can be clearly seen. Figure 107 also shows the potential benefit of the lower glazed panels.



Figure 107. Driver's eye view. All cyclists can be seen by the driver through the windscreen, with additional visibility through the right hand lower windows



Figure 108. Side view. All cyclists can be seen

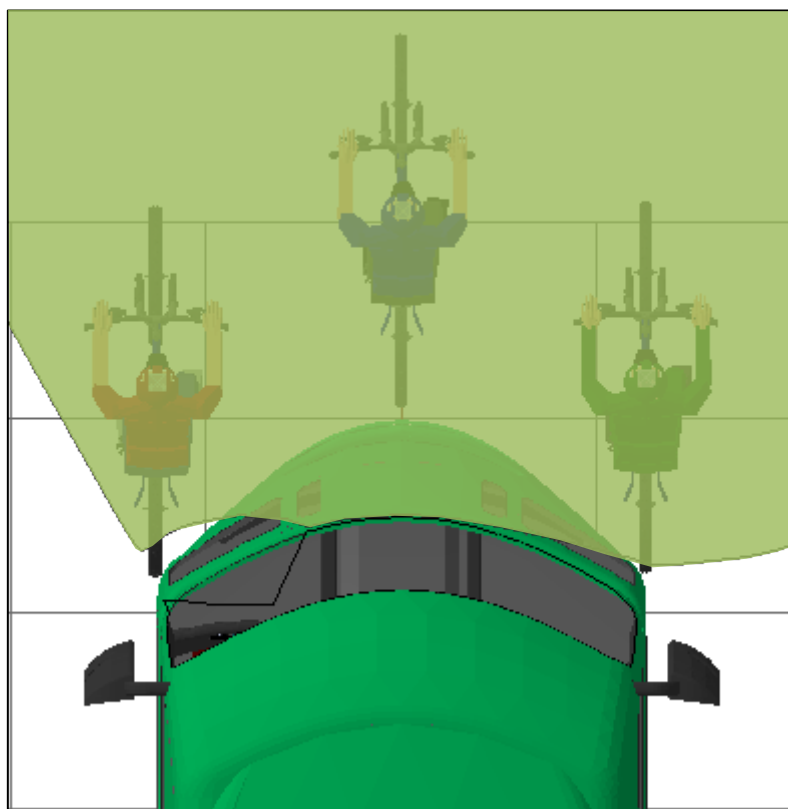

Figure 109. Plan view. All cyclists can be seen

For forwards visibility of the cyclist targets, all of the cyclists are visible to the driver.

### 3.2.4.4 OFFSIDE (DRIVER SIDE) VISIBILITY – CYCLIST

Visibility to the driver's side of the vehicle, though the side windows is shown in Figure 110, Figure 111 and Figure 112. The projections show that there is no blind spot to the driver's side of the vehicle that could obscure a cyclist. Figure 111 shows that even with the cyclist touching the side of the cab they would still be clearly visible to the driver.

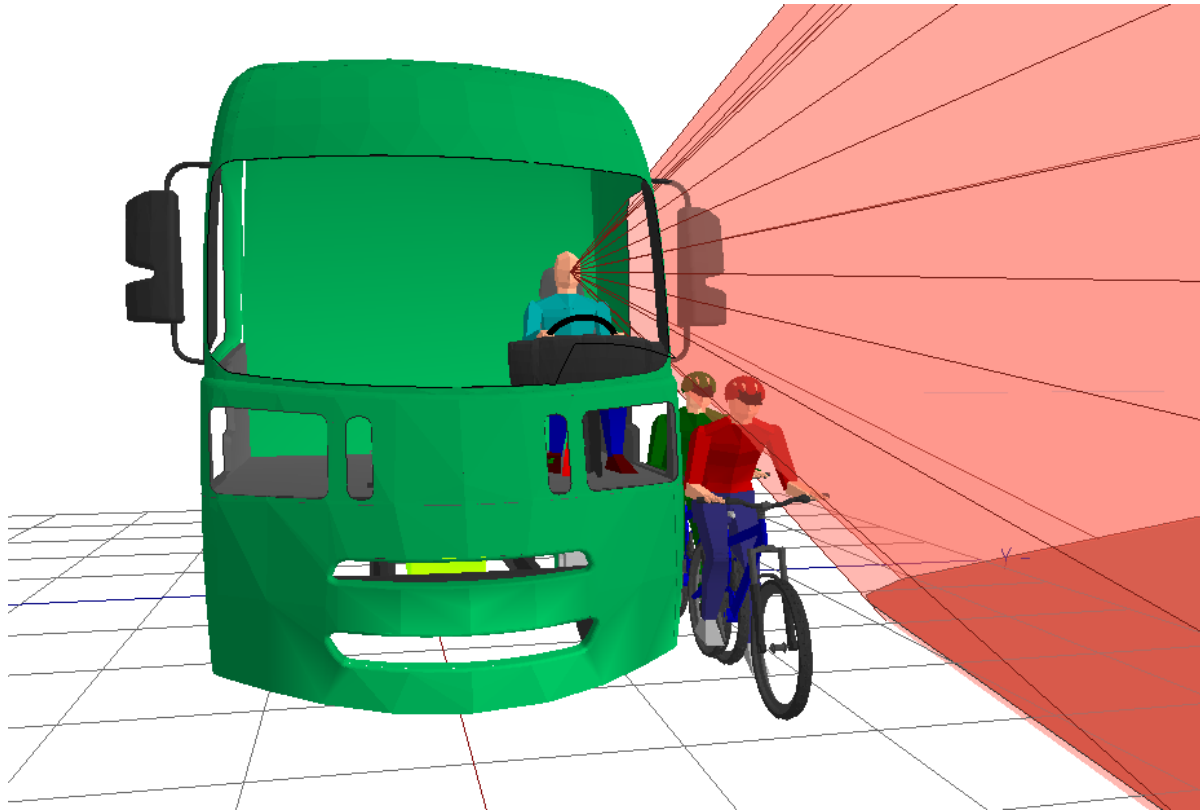

Figure 110. Front view. Both cyclists can be seen through the driver's window

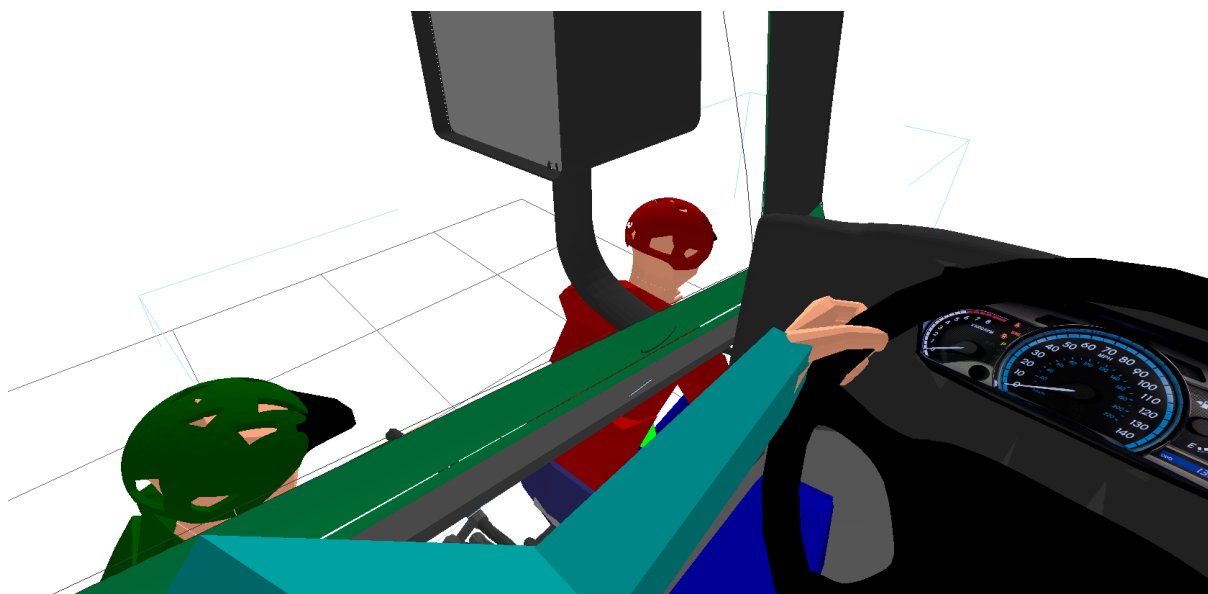

Figure 111. Driver's eye view. Both cyclists can be seen through the driver's window

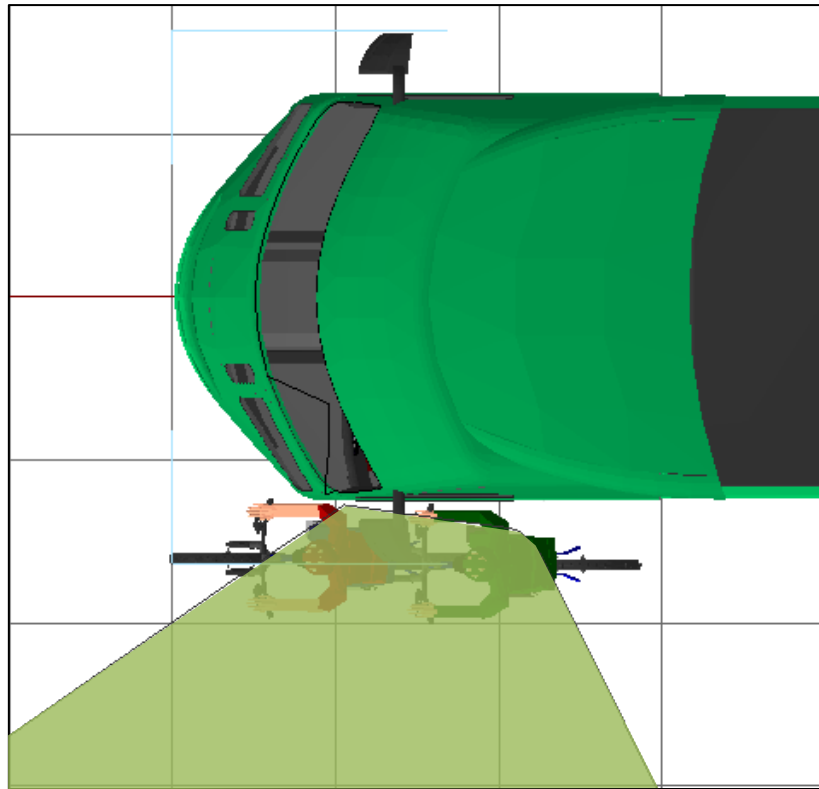

Figure 112. Plan view. Both cyclists can be seen through the driver's window

For offside visibility of the cyclist targets, both the rear (green) cyclist and the front (red) cyclist are always visible.

#### 3.2.4.5 OFFSIDE (DRIVERS SIDE) VISIBILITY – VW GOLF

Figure 113, Figure 114, and Figure 115 show the visibility to the driver's side of the vehicle with the Volkswagen Golf visual target. In this instance the car is always visible to driver through the side windows.

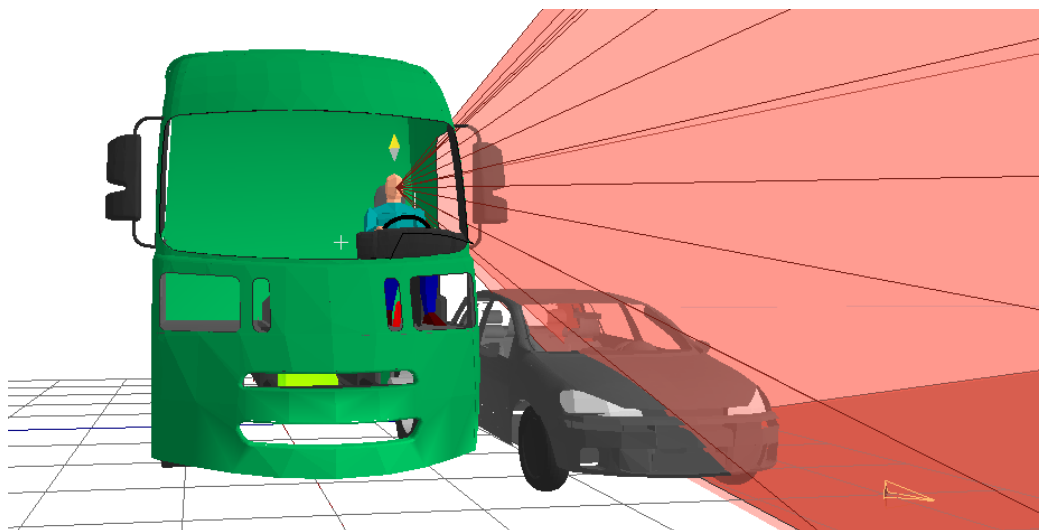

Figure 113. Front view. The car can be seen by the Category N3 vehicle driver when the car is adjacent to the driver's door.



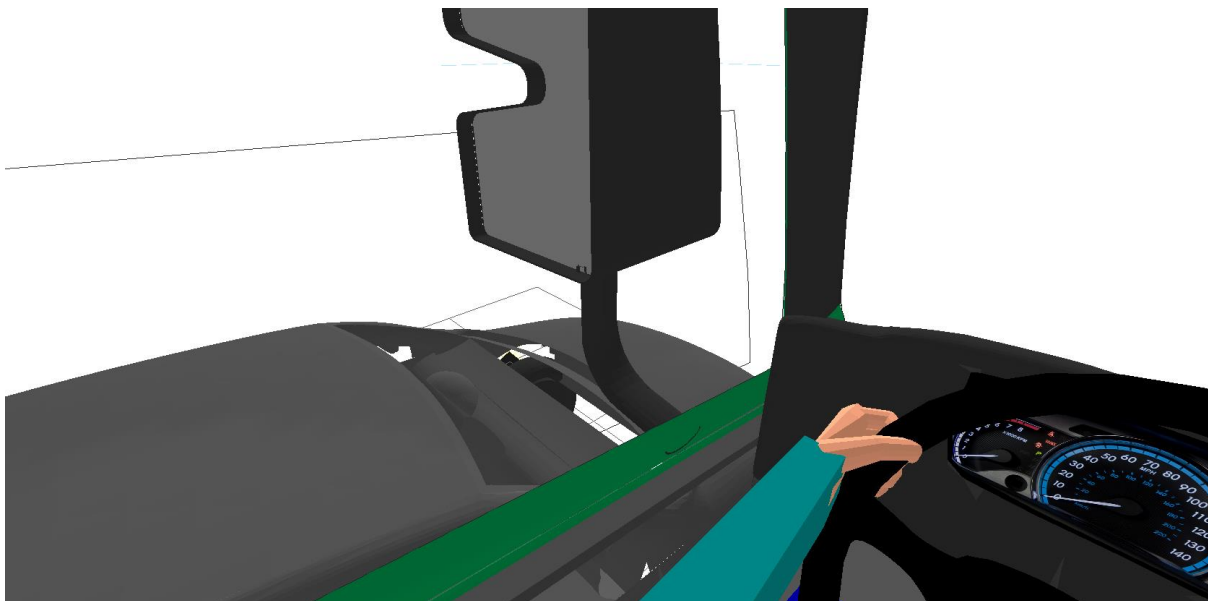

Figure 114. Driver's eye view. The car can be seen by the Category N3 vehicle driver when the car is adjacent to the driver's door.

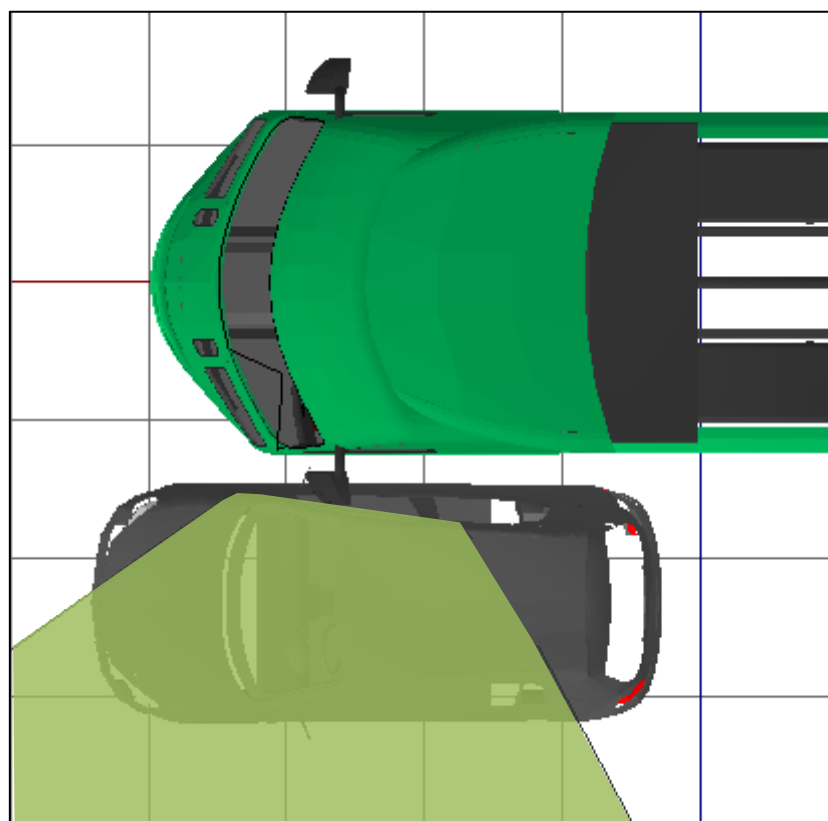

Figure 115. Plan view. The car can be seen by the Category N3 vehicle driver when the car is adjacent to the driver's door.

For offside visibility of the car, the target is always visible.

### 3.2.4.6 NEARSIDE (PASSENGER SIDE) VISIBILITY – CYCLIST

With the cyclist visual target positioned to the passenger side the blind spot in which the visual target can be hidden is again removed. Figure 117 shows that the cyclist visual target is still not be visible through the passenger window even with the reduced height cab but can be clearly seen through the panel in the lower part of the passenger door.

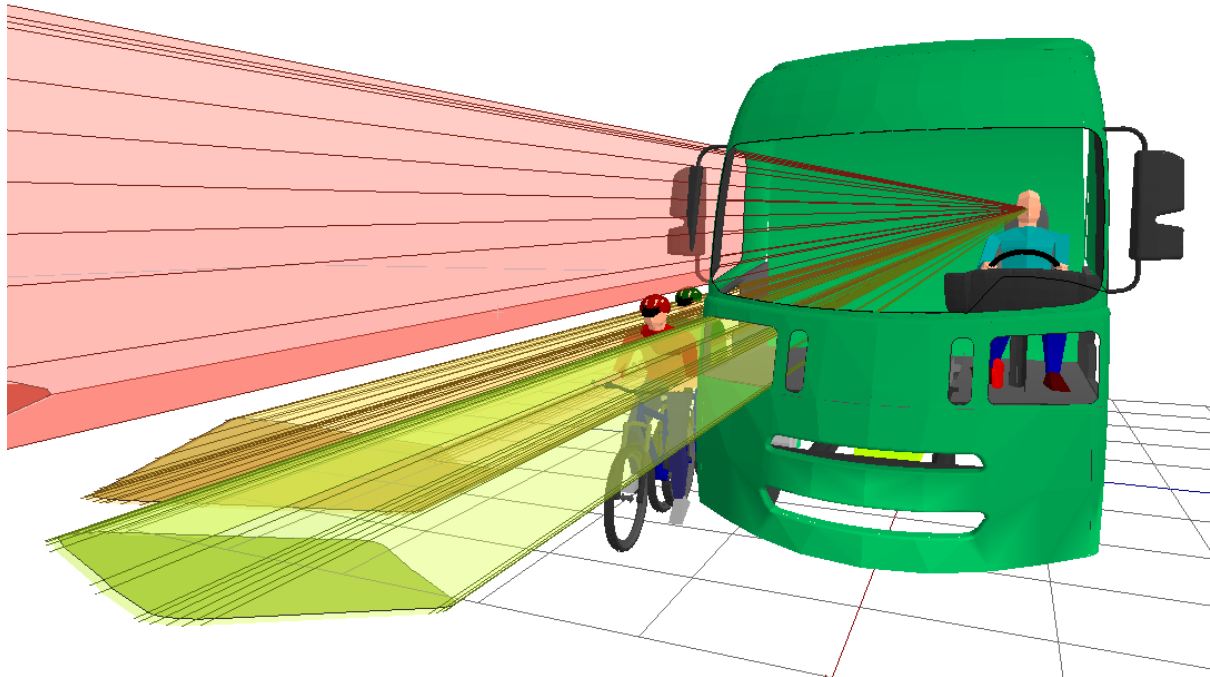

Figure 116. Front view. Both cyclists can be seen through the lower passenger window



Figure 117. Drivers eye view. Both cyclists can be seen through the lower passenger window

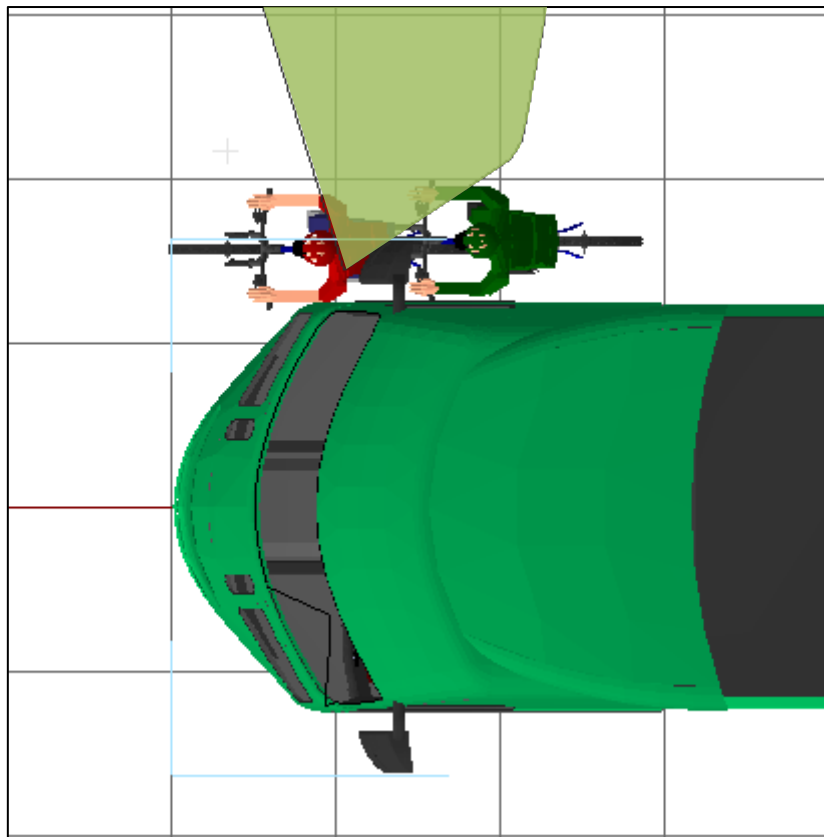

Figure 118. Plan view. Both cyclists can be seen through the lower passenger window

For nearside visibility of the cyclist targets, both the rear cyclist (green) and the front cyclist (red) are visible to the driver.

#### 3.2.4.7 NEARSIDE (PASSENGER SIDE) VISIBILITY – VW GOLF

Figure 119, Figure 120 and Figure 121 show the visibility to the passenger side of the vehicle with the Volkswagen Golf visual target. As with the cyclist visual target the blind spot to this side of the vehicle is mitigated through the lower glazed panel in the door.

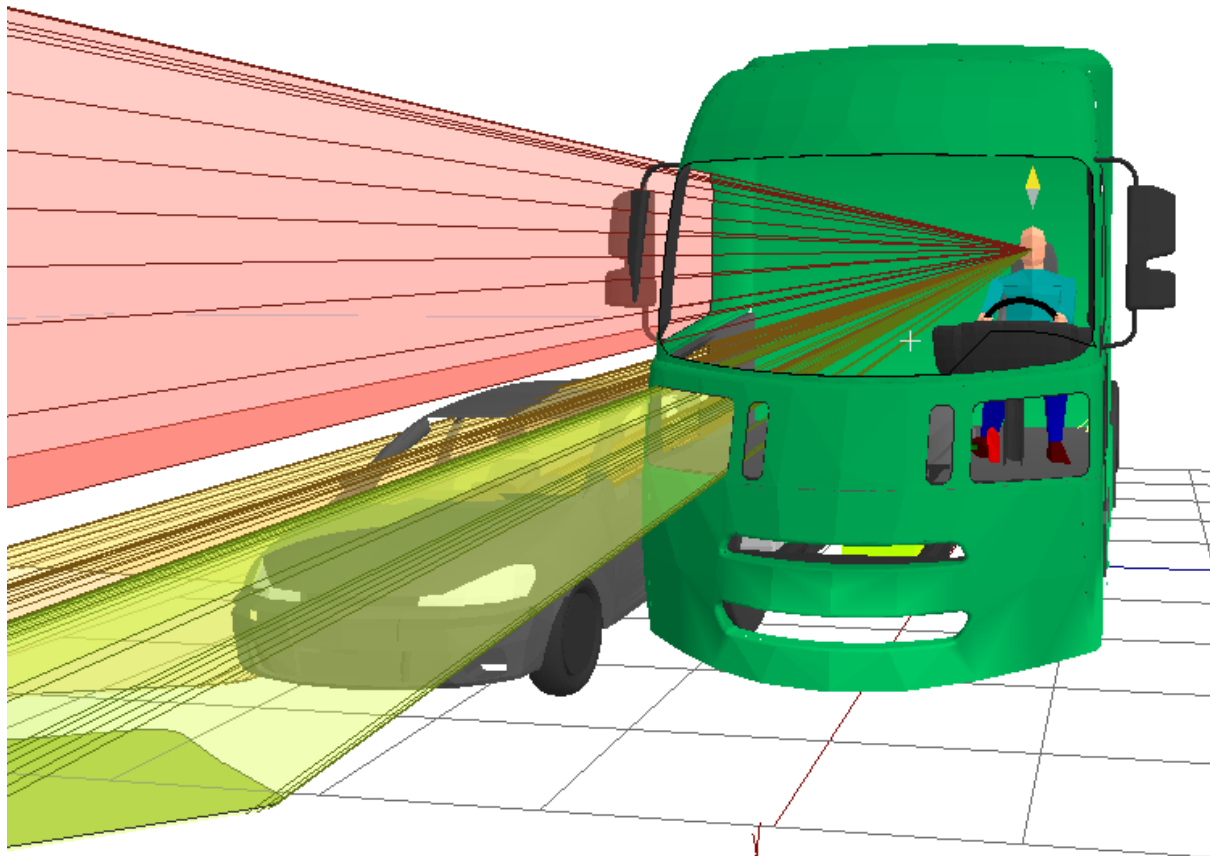

Figure 119. Front view. The car be seen by the driver of the category N3 vehicle through the lower window door and the right hand lower window



Figure 120. Driver's eye view. The car be seen by the driver of the category N3 vehicle through the lower window door and the right hand lower window

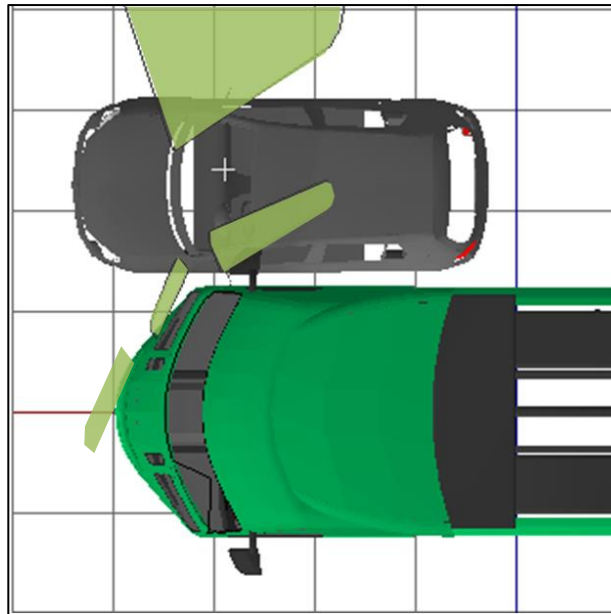

Figure 121. Plan view. The car be seen by the driver of the category N<sub>3</sub> vehicle through the lower window door and the right hand lower window

For nearside visibility of the car target, the car is always visible to the driver. Figure 122 shows the variability of the projections on the floor for the three driver eye positions that have been analysed. This shows that the lower glazed area in the passenger door is equally effective for all driver eye positions.

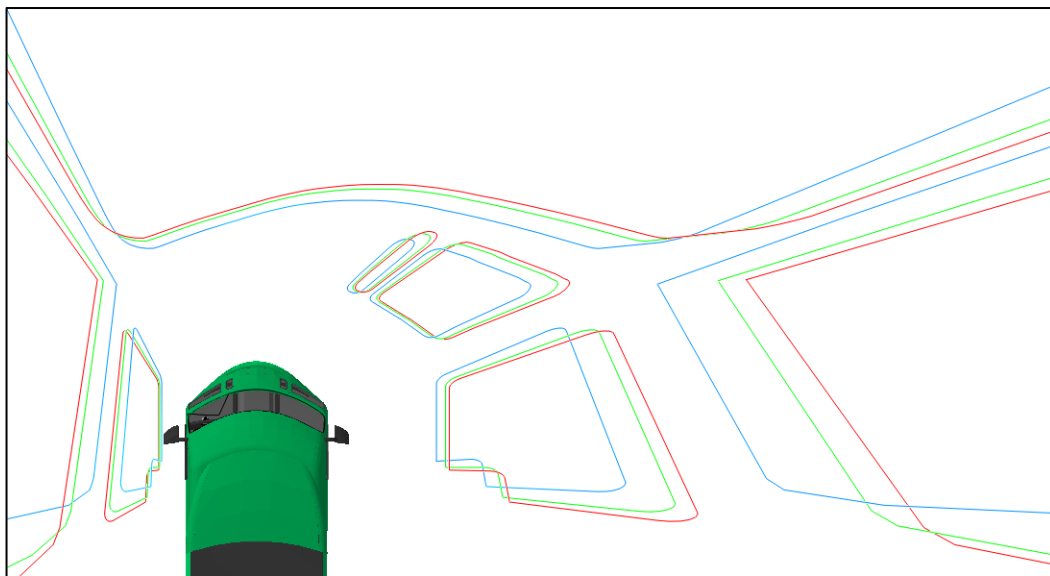

Figure 122. A plan view of the projection of the windscreen and side windows onto the floor for the FKA concept iteration 2 for a range of driver eye positions. Red=smallest driver, Green=average sized driver, and Blue=tallest driver

### 3.2.5 FKA CONCEPT ITERATION 3 - CENTRAL DRIVING POSITION

The following sections show the evaluation of the FKA Concept Iteration 3.

#### 3.2.5.1 DIRECT VISION – APERTURE PROJECTIONS

The following projections illustrate the extent of direct vision afforded to the driver via windows or other apertures in the cab. Figure 123 shows a top-down view of all of the window projections for the FKA Concept Iteration 3 cab. The image on the right of Figure 123 shows the areas of these projections that intersect with the ground. One of the clear changes from the central driving position is the symmetry fo the field of view and thus there is no difference between the nearside (passenger’s side) and offside (driver’s side).

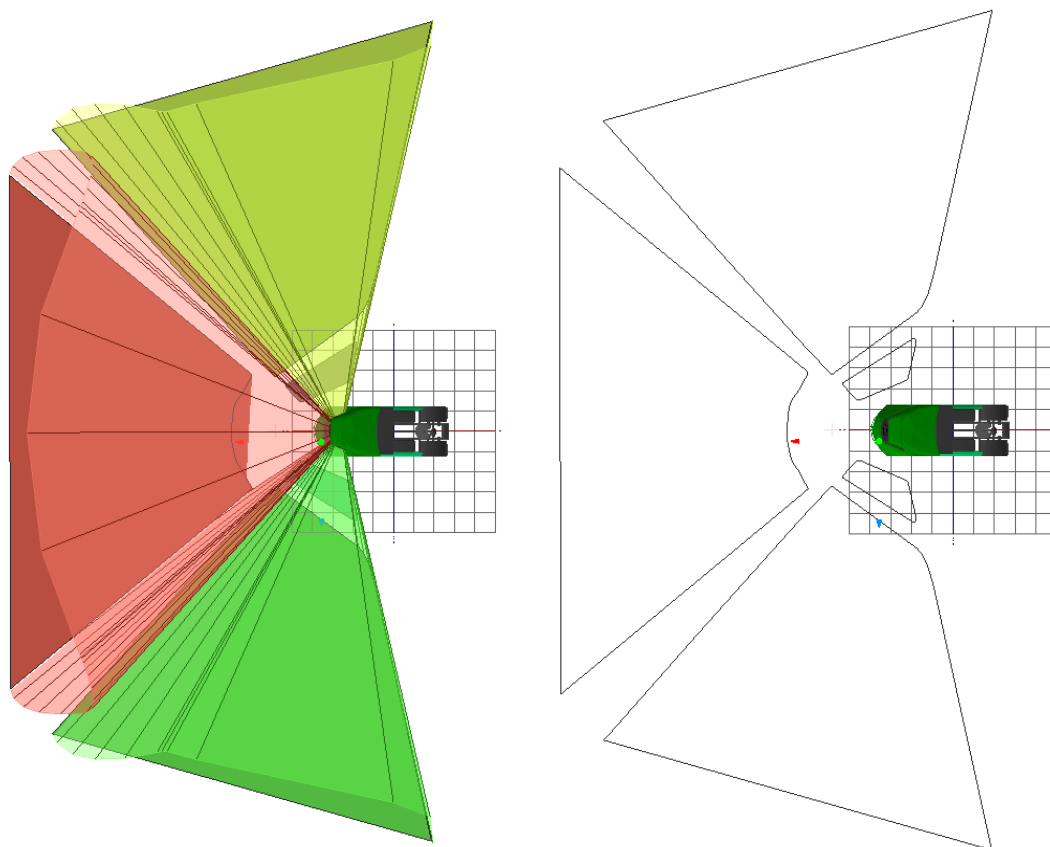

Figure 123. Plan view. The combined projections for the window apertures for the third iteration of the FKA concept

Figure 124 and Figure 125 illustrate that the projections are conical in shape, projecting from the driver’s eye point through the window aperture and beyond. Due to this conical nature some areas close to the vehicle are not visible. Anything inside the conical projection would be visible to the driver, anything not inside the projection would not be visible without the driver moving or though indirect vision such as a mirror.

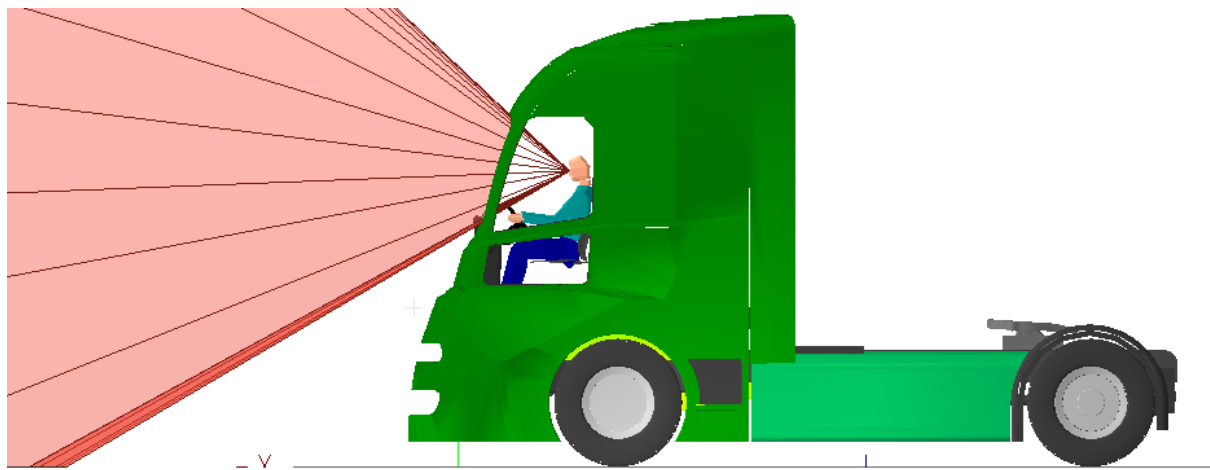

Figure 124. A side view of the wind screen aperture projection for iteration three of the FKA concept

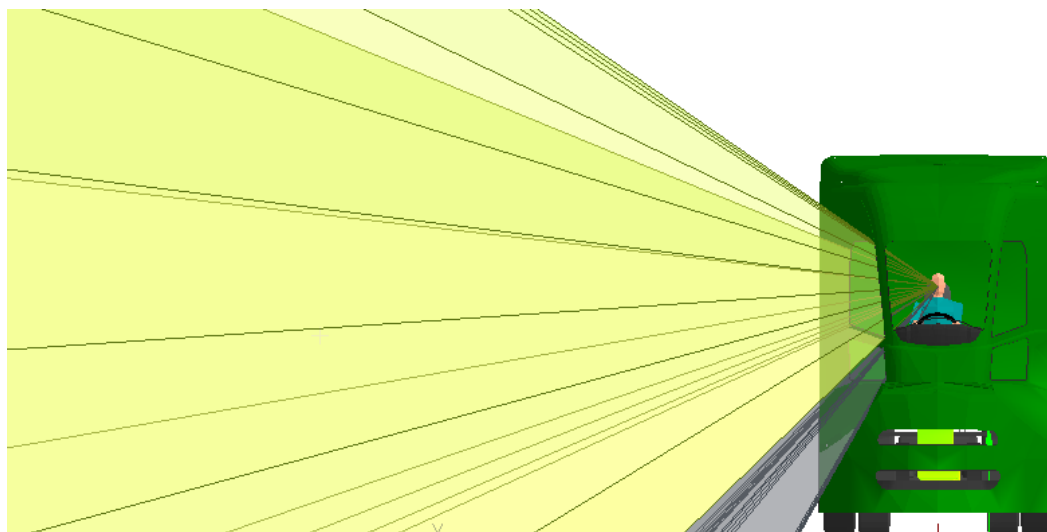
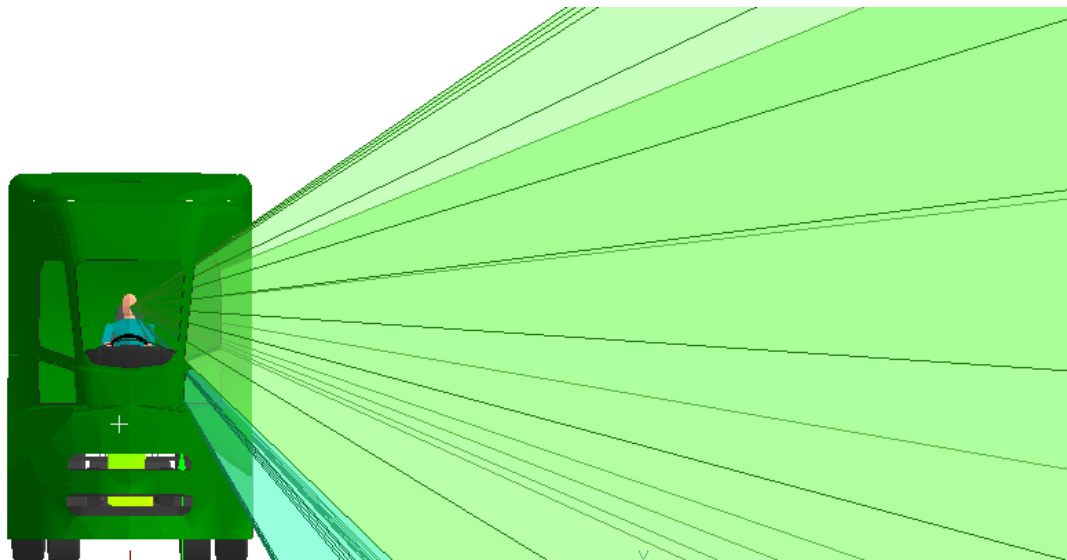

Figure 125. Frontal views of the near side and off side door window projections

### 3.2.5.2 FORWARD VISIBILITY – PEDESTRIAN

Figure 126, Figure 127 and Figure 128 show a small blind spot immediately in front of the vehicle. Figure 127 highlights that the left (red) and right (blue) visual target would be visible through the lower glazed panels in the doors. However the central (green) pedestrian is not visible.

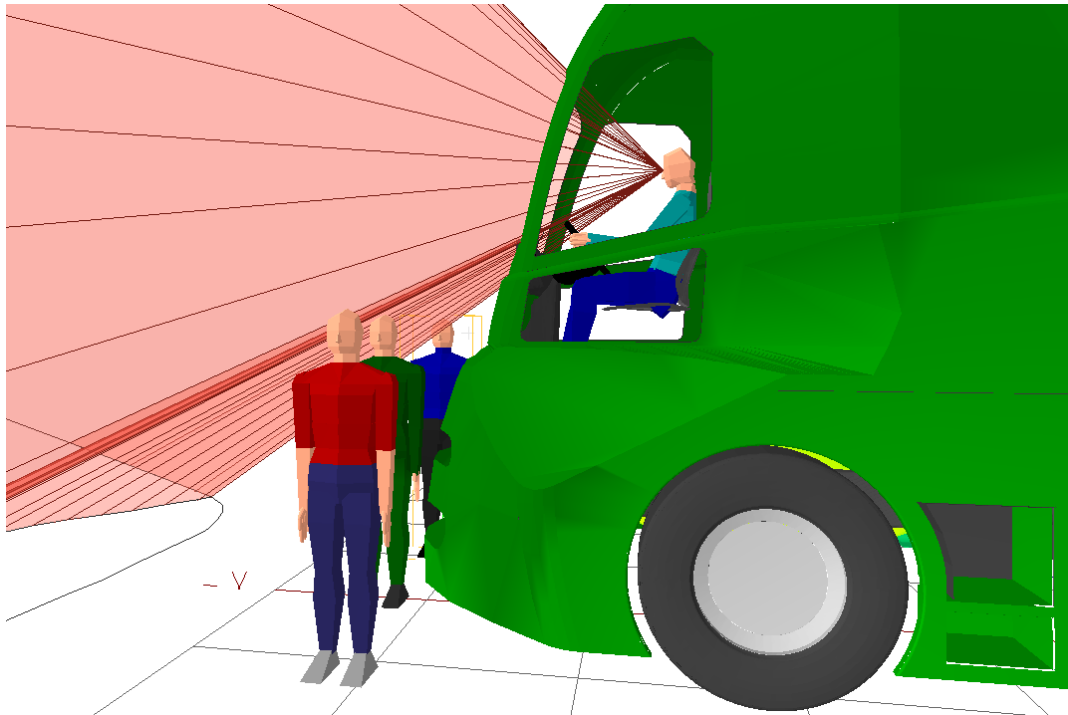

Figure 126. Side view. The red and blue pedestrians can be seen. The green pedestrian can be 97mm in front of the centre of the vehicle and not be seen due to obscuration by the dash structure



Figure 127. Driver's eye view. The red and blue pedestrians can be seen. The green pedestrian can be 97mm in front of the centre of the vehicle and not be seen due to obscuration by the dash structure



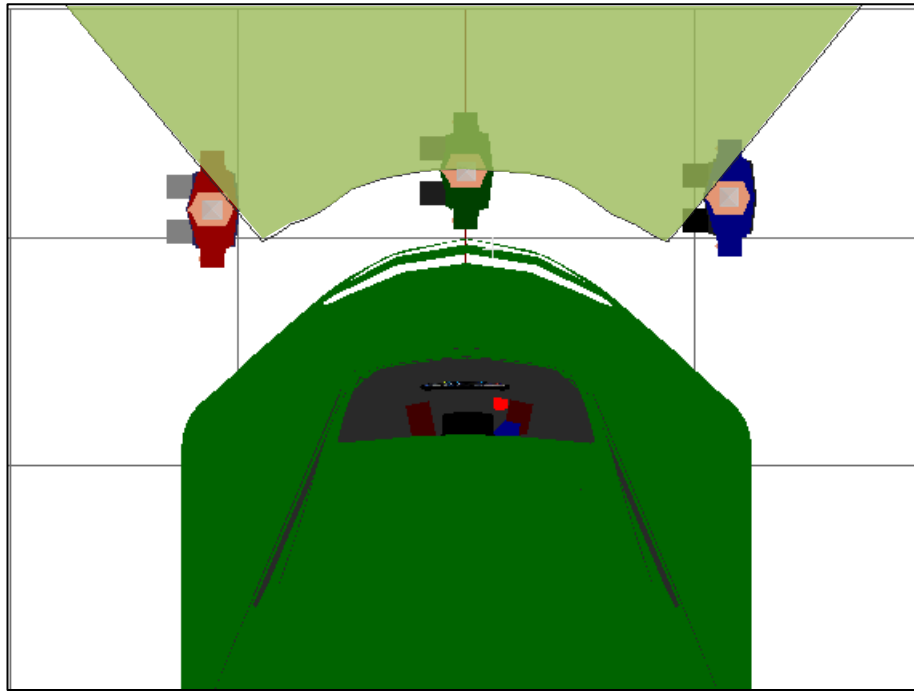

Figure 128. Plan view. The red and blue pedestrians can be seen. The green pedestrian can be 97mm in front of the vehicle and not be seen due to obscuration by the dashboard

For visibility of the pedestrian targets, the left (red) and right (blue) pedestrians are always visible, the central (green) pedestrian can be hidden from the driver's view. The green pedestrian is positioned at 97mm from the front of the vehicle.

### 3.2.5.3 FORWARD VISIBILITY – CYCLIST

Figure 130 and Figure 131 show that it is not possible for the cyclist visual targets to the front of the cab to be hidden from the driver's view. The three cyclists shown are all effectively touching the front of the vehicle and as shown in Figure 129 all three can be clearly seen through a combination of the windscreen, the door windows and the lower door panels.

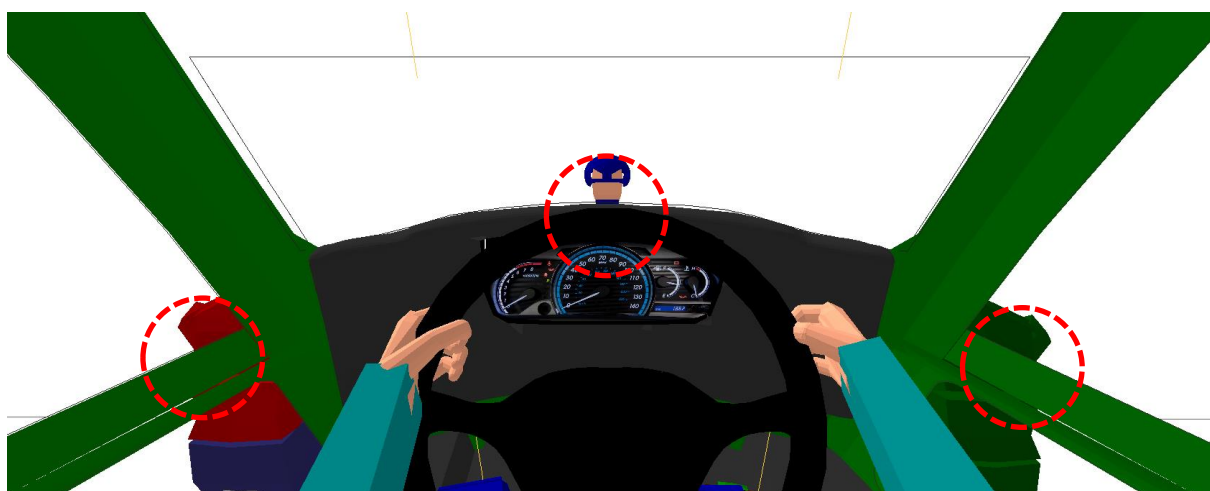

Figure 129. Driver's eye view. All cyclists can be seen by the driver

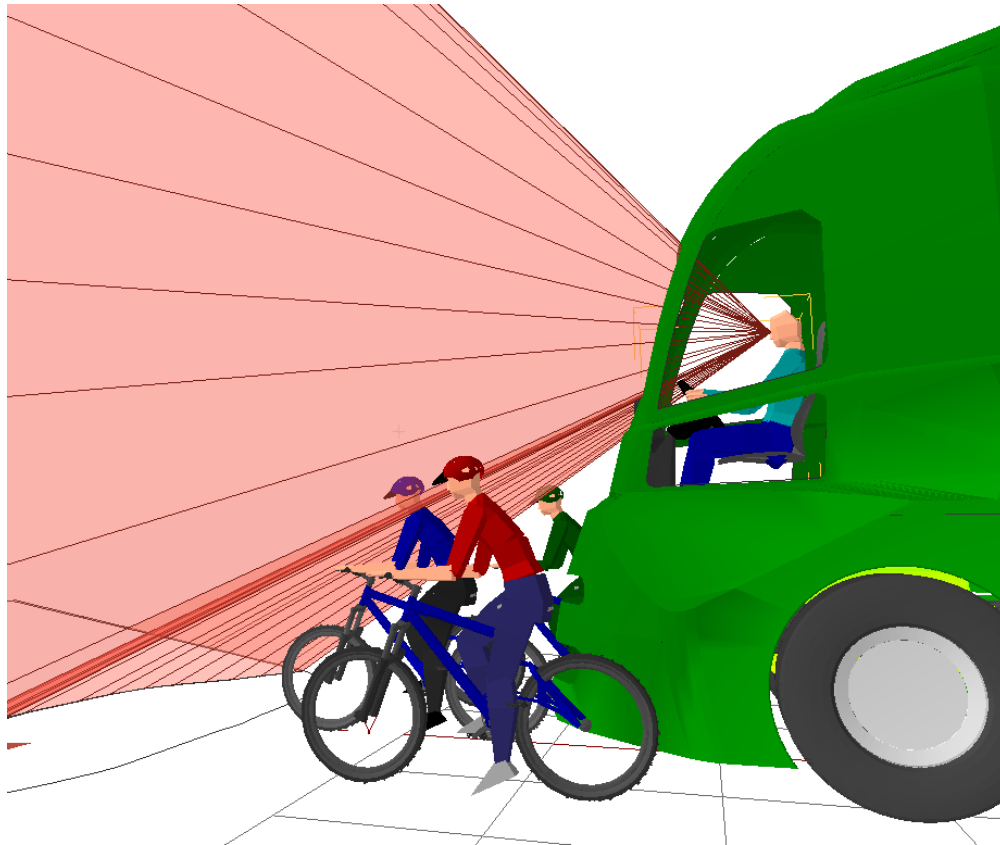

Figure 130. Side view. Driver's eye view. All cyclists can be seen by the driver

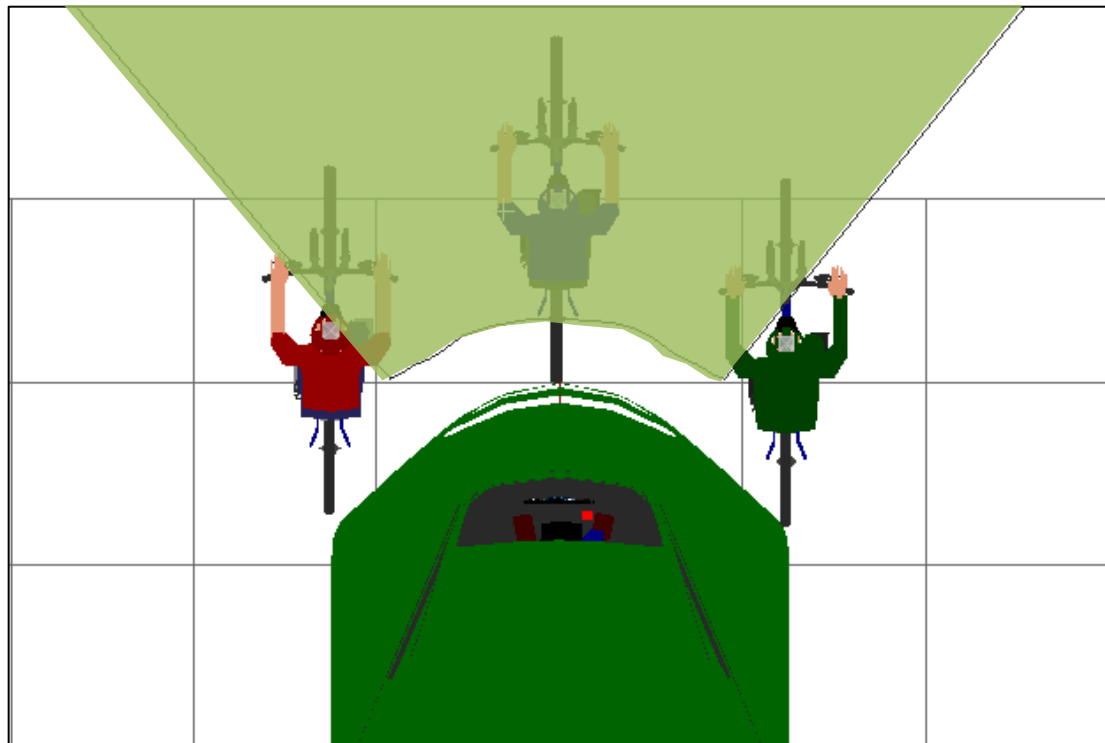

Figure 131. Plan view. Driver's eye view. All cyclists can be seen by the driver

For forwards visibility of the cyclist targets, all of the cyclists are visible to the driver.

### 3.2.5.4 OFFSIDE (DRIVER SIDE) VISIBILITY – CYCLIST

Visibility to the offside of the vehicle, though the side windows is shown in Figure 132, Figure 133 and Figure 134. The projections show that there is no blind spot to this side of the vehicle that could obscure a cyclist. Figure 133 shows that even with the cyclist touching the side of the cab they would still be clearly visible to the driver.

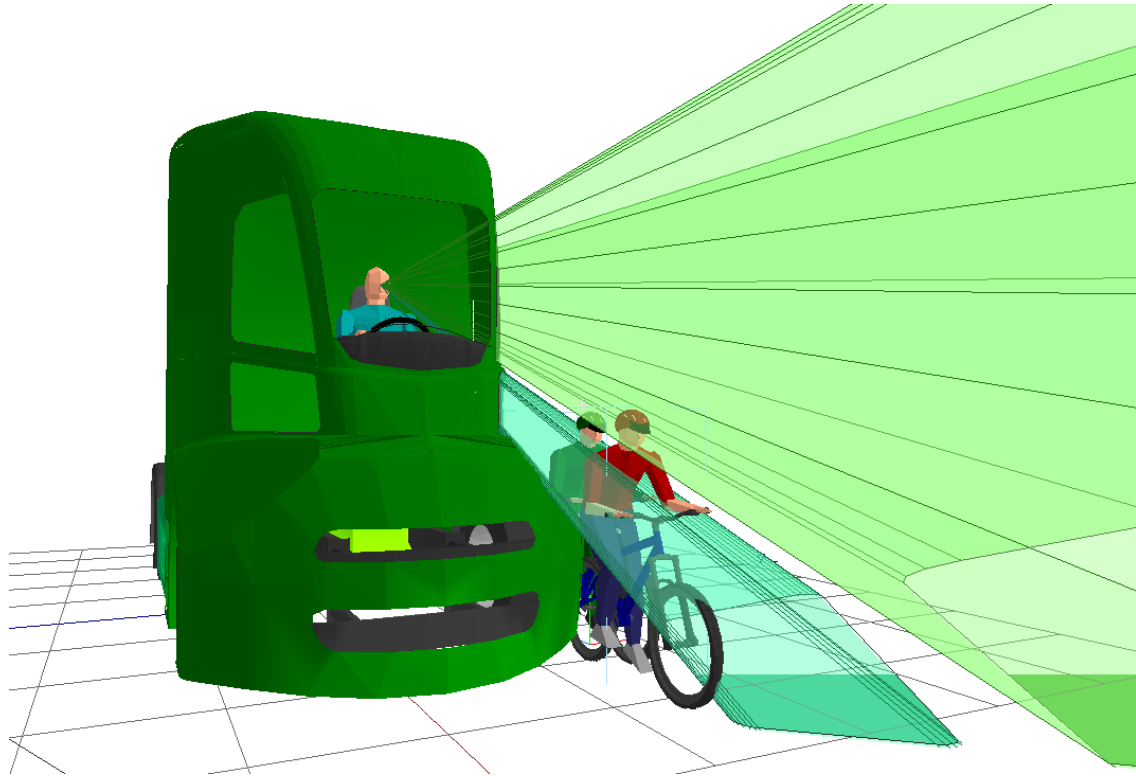

Figure 132. Front view. Driver's eye view. All cyclists can be seen by the driver

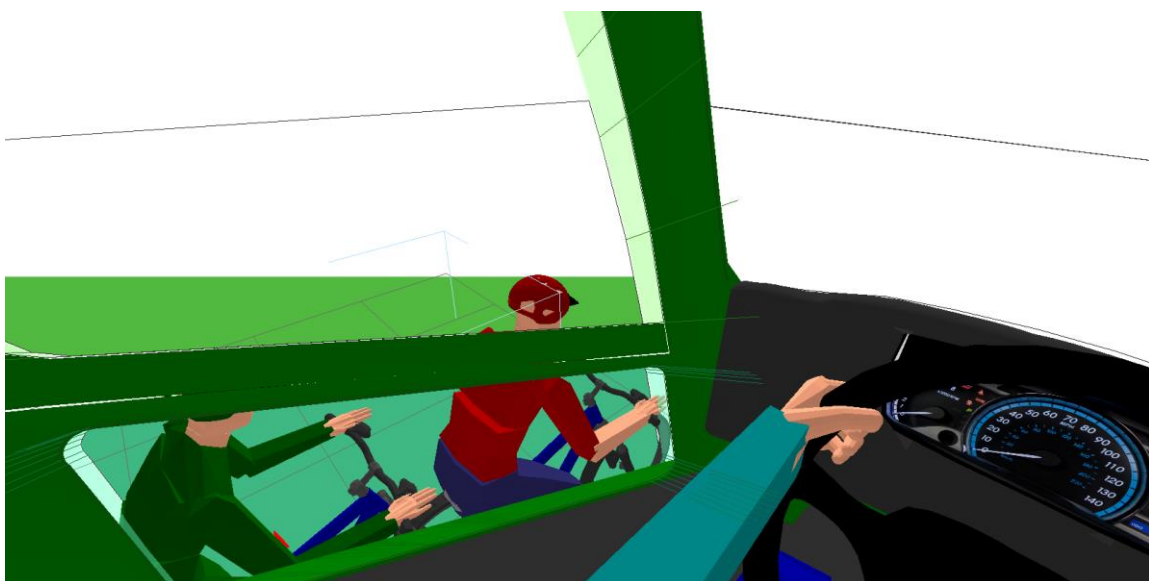

Figure 133. Driver's eye view. All cyclists can be seen by the driver

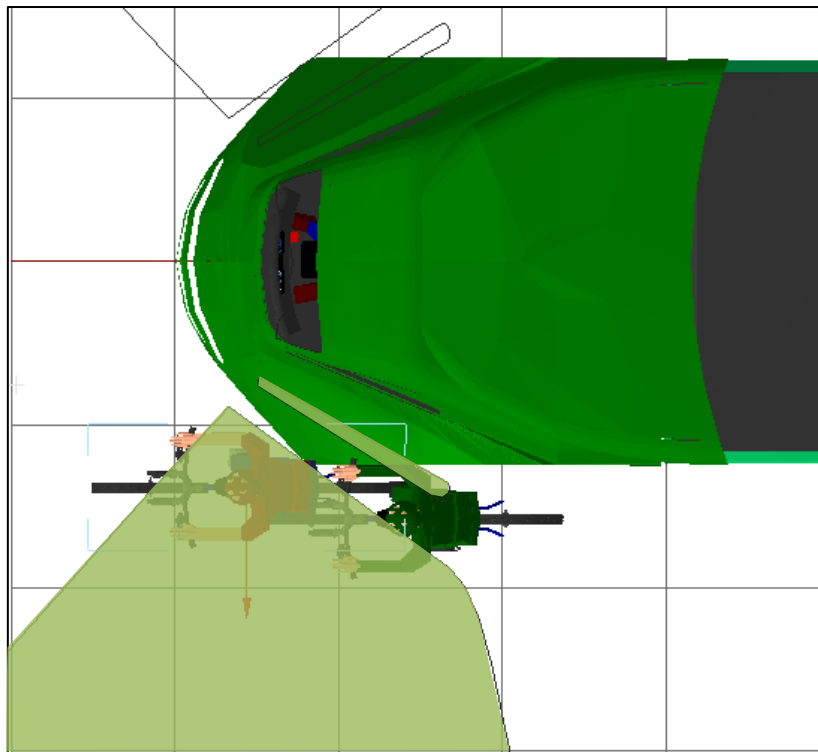

Figure 134. Plan view Driver's eye view. All cyclists can be seen by the driver

For offside visibility of the cyclist targets, both the rear (green) cyclist and the front (red) cyclist are always visible.

### 3.2.5.5 OFFSIDE (DRIVER SIDE) VISIBILITY – VW GOLF

Figure 132, Figure 133, and Figure 134 show the visibility to the offside of the vehicle with the Volkswagen Golf visual target. In this instance the car is always visible to driver through the side windows.

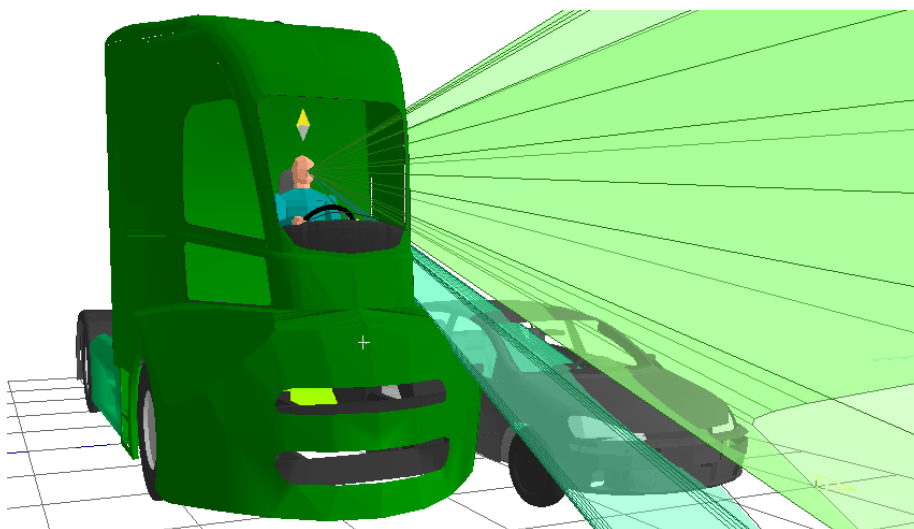

Figure 135. Front view. The car can be seen by the driver of the category N<sub>3</sub> vehicle.

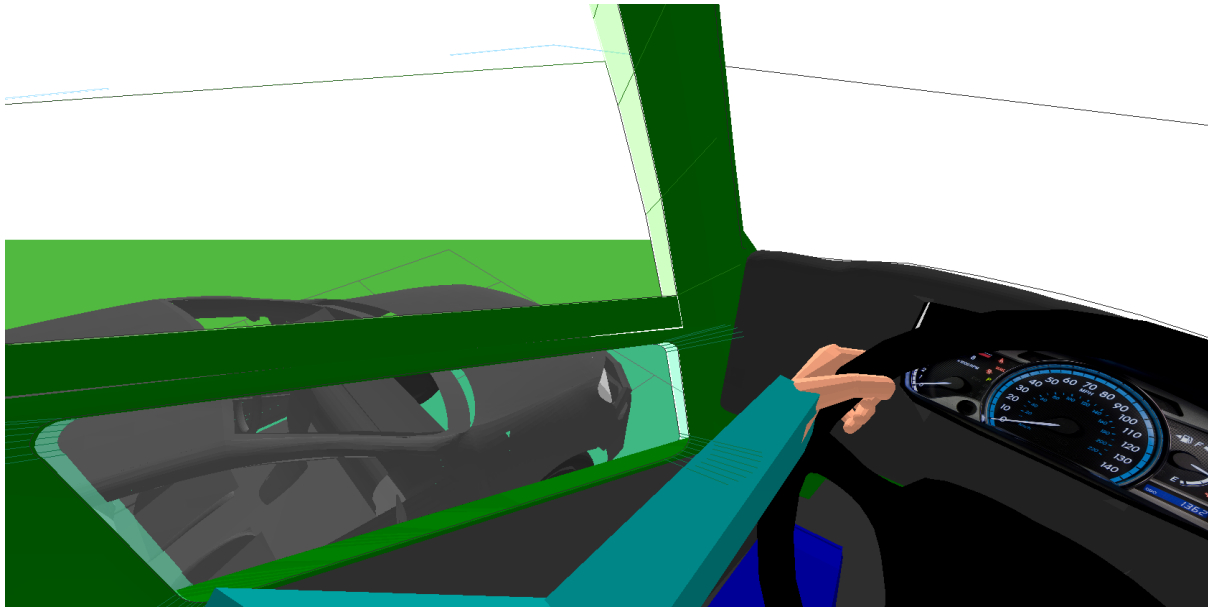

Figure 136. Driver's eye view. The car can be seen by the driver of the category N3 vehicle.

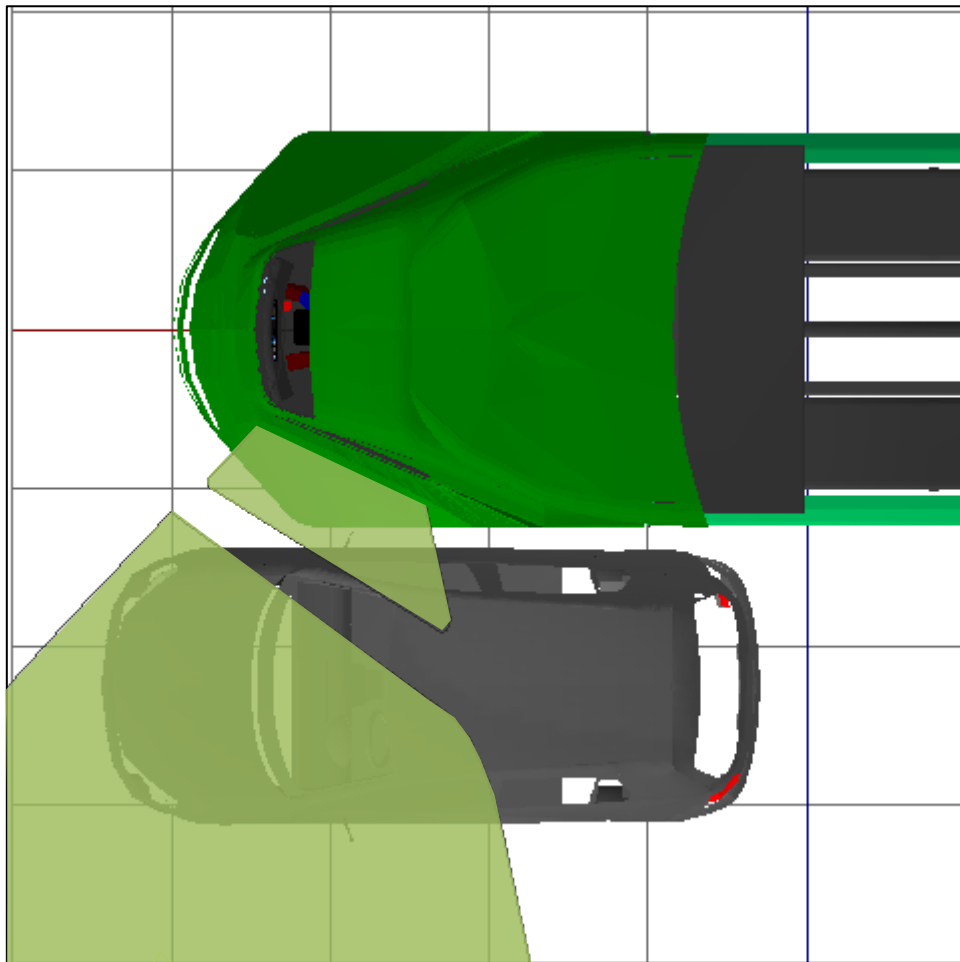

Figure 137. Plan view. The car can be seen by the driver of the category N3 vehicle.

For offside visibility of the car, the target is always visible.

### 3.2.5.6 NEARSIDE (PASSENGER SIDE) VISIBILITY – CYCLIST

With the cyclist visual target positioned to the nearside the results are the same as for the offside due to the symmetry of the field of view. Figure 139 shows that the cyclist visual targets are clearly visible through a combination of the side upper and lower windows.

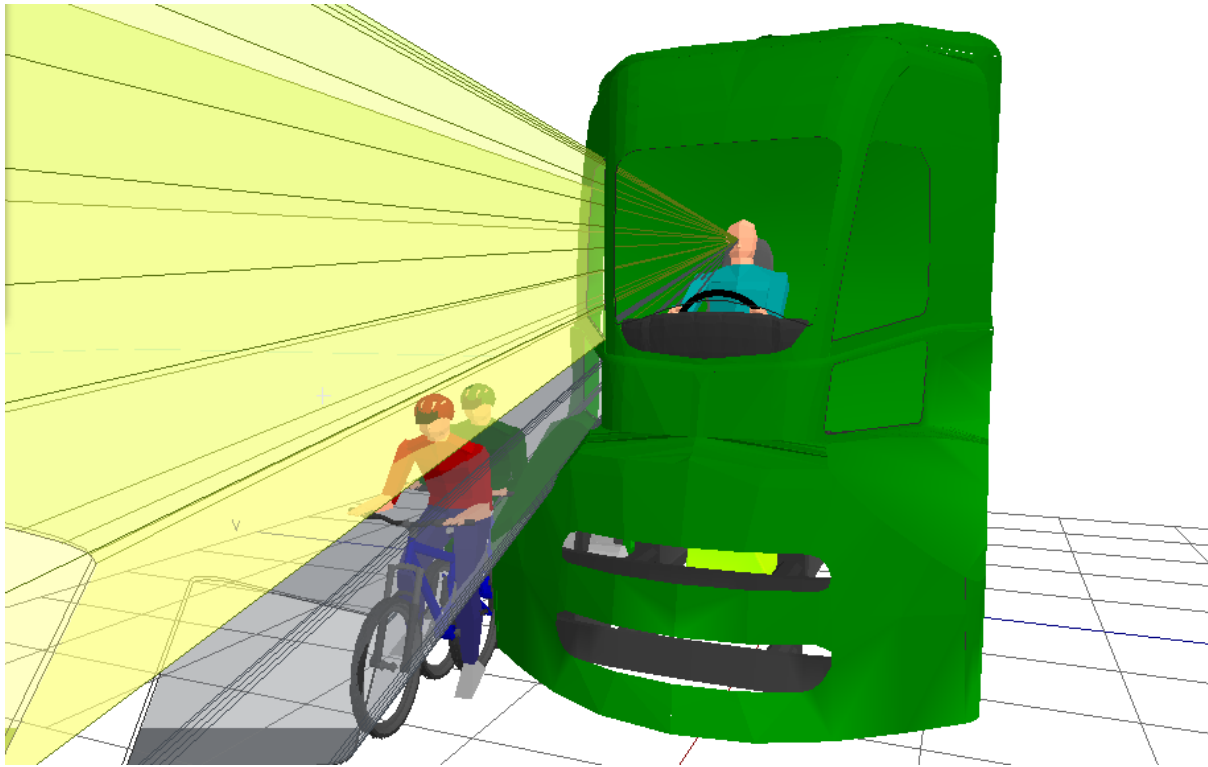

Figure 138. Front view Driver's eye view. All cyclists can be seen by the driver

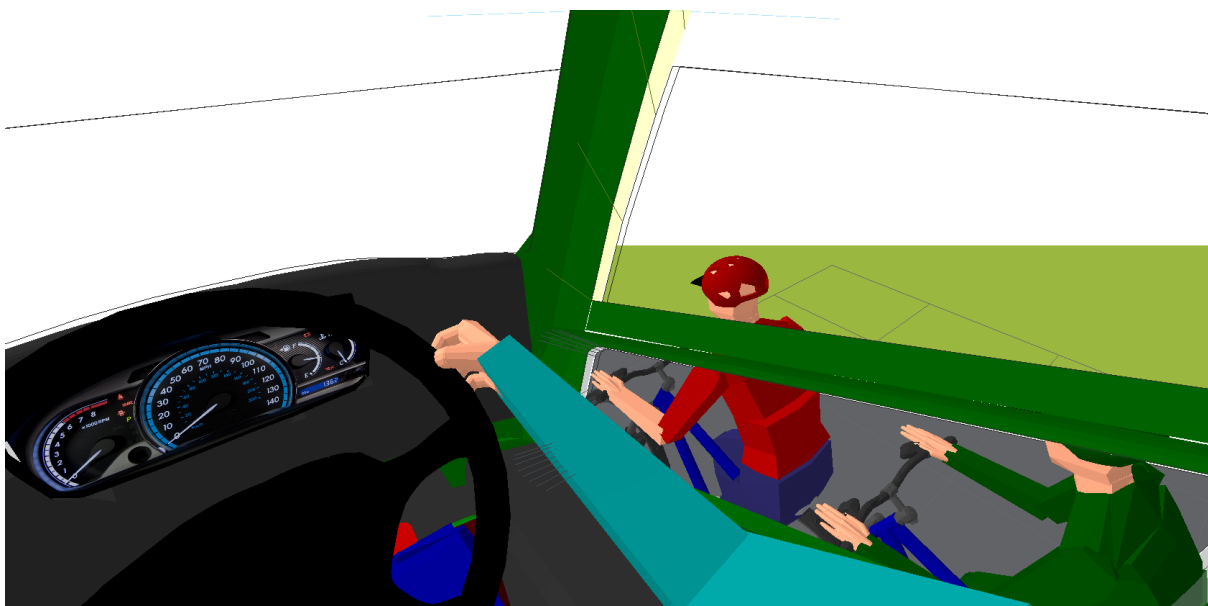

Figure 139. Driver's eye view, Driver's eye view. All cyclists can be seen by the driver

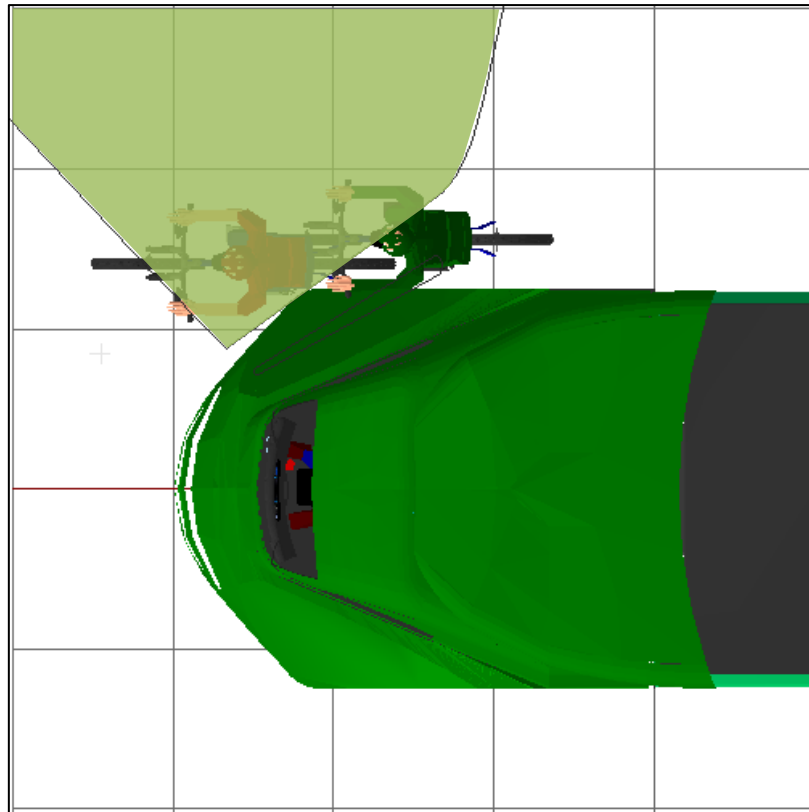

Figure 140. Plan view. Driver's eye view. All cyclists can be seen by the driver

For nearside visibility of the cyclist targets, both the rear cyclist (green) and the front cyclist (red) are visible to the driver.

### 3.2.5.7 NEARSIDE (PASSENGER SIDE) VISIBILITY – VW GOLF

Figure 141, Figure 142 and Figure 143 show the visibility to the passenger side of the vehicle with the Volkswagen Golf visual target. As with the cyclist visual target the blind spot to this side of the vehicle is mitigated through the lower glazed panel in the door.

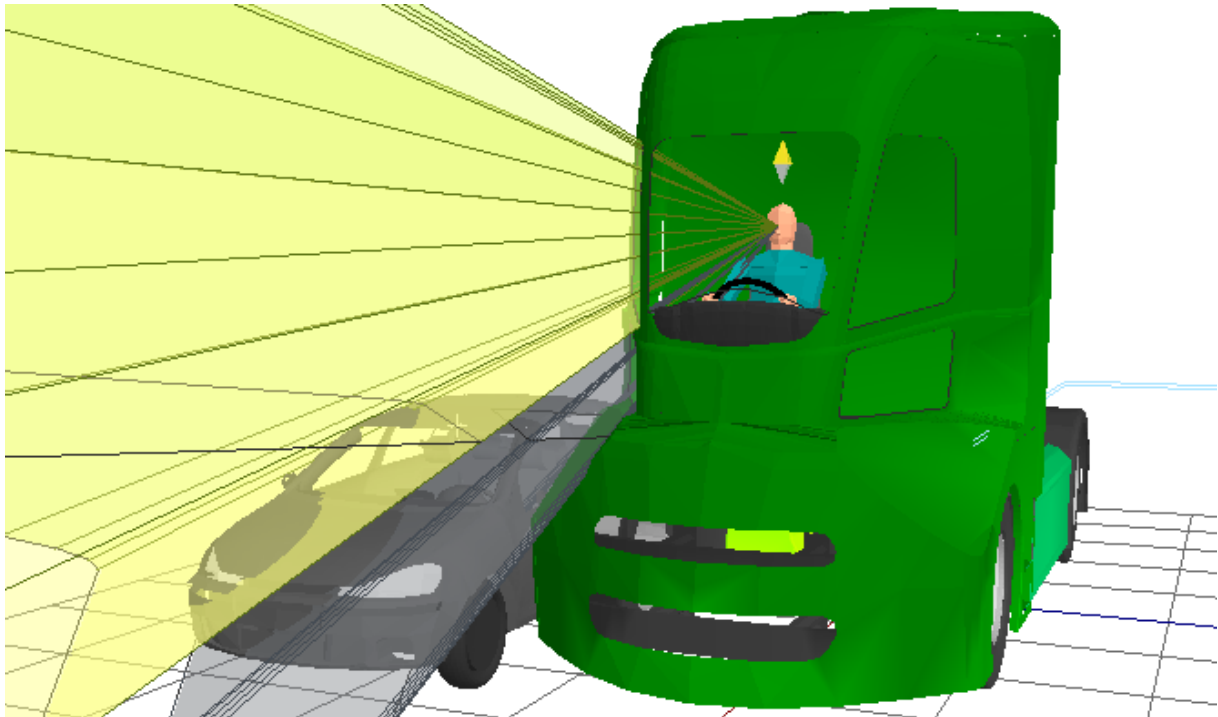

Figure 141. Front view. Plan view. The car can be seen by the driver of the category N<sub>3</sub> vehicle.



Figure 142. Driver's eye view. Plan view. The car can be seen by the driver of the category N<sub>3</sub> vehicle.



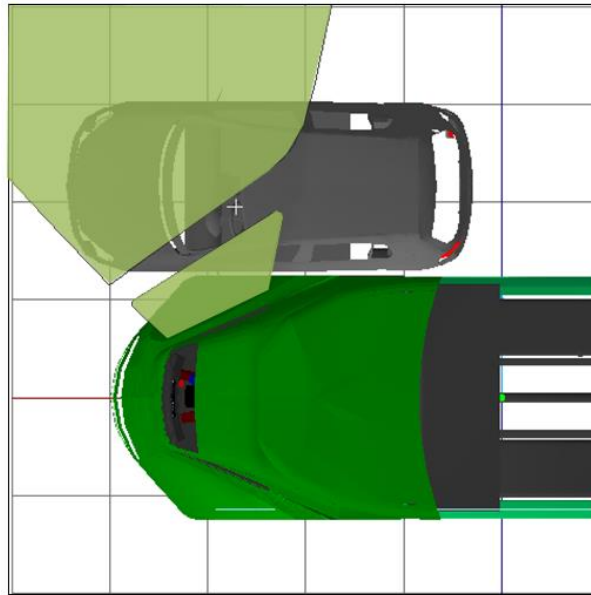

Figure 143. Plan view. The car can be seen by the driver of the category N3 vehicle.

For nearside visibility of the car target, the car is always visible to the driver. Figure 144 shows the variability of the projections on the floor for the three driver eye positions that have been analysed. This shows that the lower glazed areas in the driver and passenger doors are equally effective for all driver eye positions.

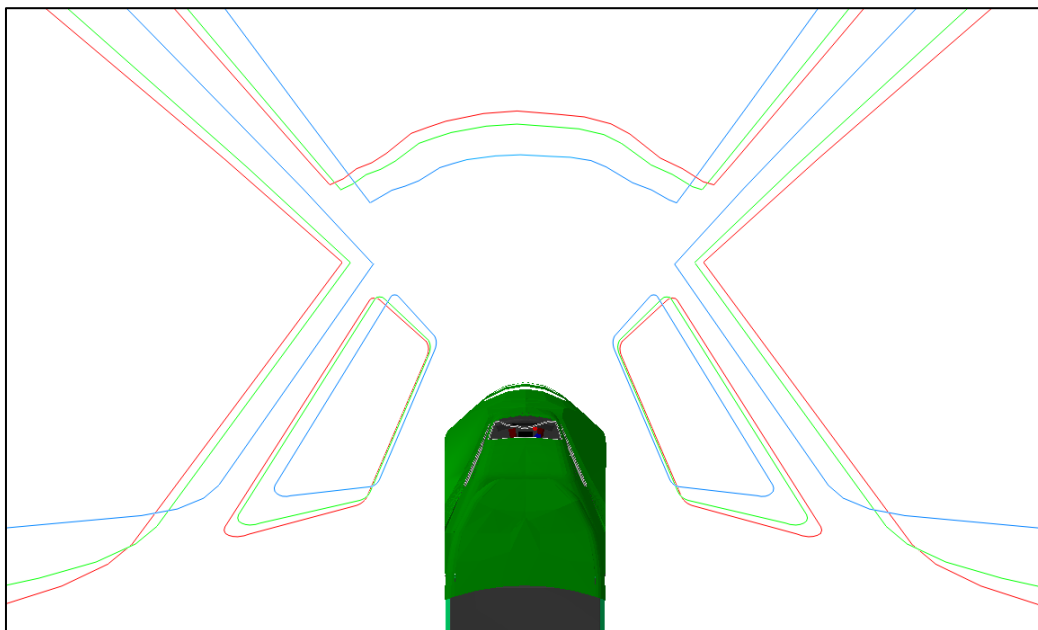

Figure 144. A plan view of the projection of the windscreen and side windows onto the floor for the FKA concept iteration 3 for a range of driver eye positions. Red=smallest driver, Green=average sized driver, and Blue=tallest driver

### 3.3 RESULTS COMPARISON BETWEEN VEHICLE DESIGNS

The following sections summarise the results for the five vehicle configurations that have been analysed in terms of direct vision in front of and to the sides of the vehicle. The plan views highlight the ability of the visual target to be obscured from the direct vision of the driver of the vehicle, with red markers indicating that the visual target can be obscured from the driver. In addition, the distance of the obscured visual target away from vehicle highlights the severity of the obscuration. For example, in the section below the pedestrian visual targets are shown as obscured for the baseline DAF XF 105 vehicle, and there is clear distance between the pedestrians and the front of the vehicle. Any location of the pedestrian visual targets closer to the vehicle would not be visible to the driver.

### 3.3.1.1 FORWARD VISIBILITY – PEDESTRIAN

The DAF XF has the ability to obscure all three of the pedestrian visual targets. The three visual target human models can stand 690mm (left pedestrian), 575mm (middle pedestrian) and 647mm (right pedestrian) in front of the vehicle without being seen by the driver in the standardised driving posture.

The FKA concept improves the situation with the middle pedestrian being visible to the driver. The left and right pedestrians can be obscured at distances of 485mm and 530mm respectively forward of the vehicle.

The 1<sup>st</sup> iteration of the FKA concept allows the middle and right pedestrian to be visible to the driver. The left hand pedestrian can be obscured from the driver at a distance of 141mm from the vehicle.

The 2<sup>nd</sup> iteration of the FKA concept allows all of the pedestrian visual targets to be visible to the driver through the main windscreen.

The 3<sup>rd</sup> iteration of the FKA concept obscures the middle pedestrian through the obscuration created by the dashboard structure and the driving position that is further forward than the other vehicle designs. The left and right visual targets are partially visible through the side windows.

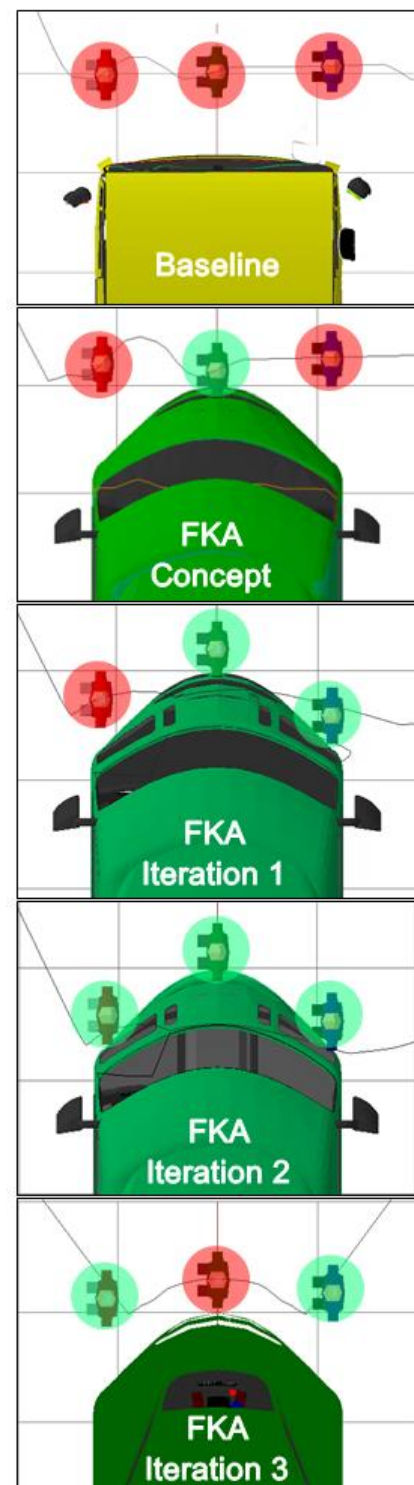

### 3.3.1.2 FORWARD VISIBILITY – CYCLIST

The DAF XF allows the left and middle cyclists to be visible to the driver, with a small portion of the top of the helmets visible. The close proximity of the cyclists to the vehicle means that if the cyclists were to move further forward to create a clearance with the vehicle, more of the visual target would be visible. The right hand cyclist is obscured from the driver.

The FKA concept improves the visibility of the middle cyclist considerably, with the head and shoulders being visible to the driver. A small portion of the cyclist's helmet is visible to the driver for the left hand cyclist. The right hand cyclist is not visible to the driver. Again, moving the cyclists further forward to provide a clearance from the vehicle would improve direct vision for all visual cyclists.

The 1<sup>st</sup> iteration of the FKA concept allows all cyclists to be seen, with the additional windows on the right hand side of the cab providing vision of the right hand cyclist. Only a small portion of the left hand cyclist helmet is visible.

The 2<sup>nd</sup> iteration of the FKA concept allows at least the head and shoulders of all cyclist visual targets as defined to be visible to the driver.

The 3<sup>rd</sup> iteration of the FKA concept allows the head to be visible for the middle cyclist, and a shoulder and the back of the left and right hand cyclists to be visible to the driver.

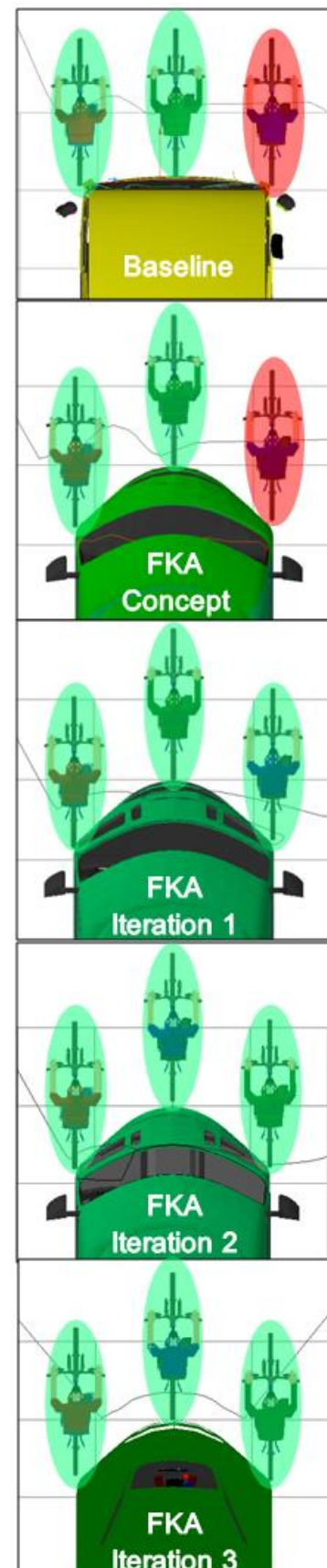

### 3.3.1.3 NEARSIDE (PASSENGER SIDE) VISIBILITY – CYCLIST

The DAF XF allows the cyclist to the right of the vehicle to be completely obscured from the direct vision of the driver at distance up to 1903mm from the passenger side of the vehicle.

The FKA concept allows the cyclist to the right of the vehicle to be completely obscured from the direct vision of the driver at distance up to 1458mm from the passenger side of the vehicle.

The 1<sup>st</sup> iteration of the FKA concept allows the cyclists in the locations shown to be clearly visible the driver through the lower passenger door window.

The 2<sup>nd</sup> iteration of the FKA concept allows the cyclists in the locations shown to be clearly visible the driver through the lower passenger door window.

The 3<sup>rd</sup> iteration of the FKA concept allows the cyclists in the locations shown to be clearly visible the driver through the lower passenger door window.

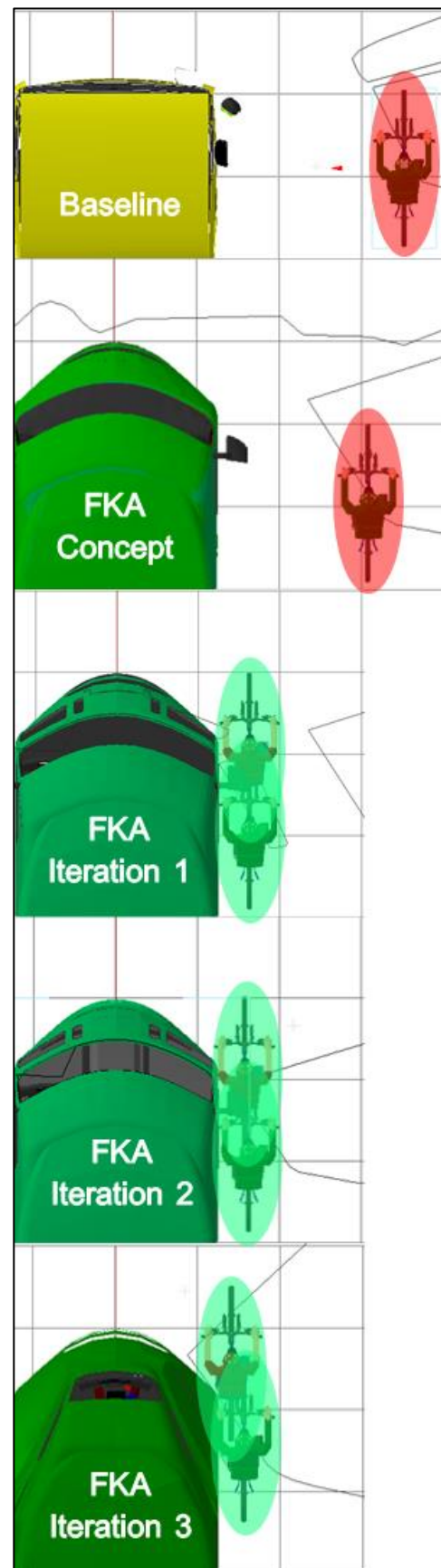

### 3.3.1.4 OFFSIDE (DRIVER SIDE) VISIBILITY – CYCLIST

The DAF XF allows the cyclist to the right of the vehicle to the left of the vehicle in the locations shown to be completely obscured from the driver. They are however in very close proximity to the vehicle and any lateral motion to improve the clearance to the vehicle side would allow the cyclists to be at least partially visible to the driver.

The FKA concept allows the helmet of the foremost cyclist to be visible to the driver. Only a small portion of the rearmost cyclist's helmet is visible. Again, the cyclists are in close proximity and any further lateral clearance between the cyclist and the vehicle would improve the proportion of the cyclists that can be seen.

The 1<sup>st</sup> iteration of the FKA concept shows the same results as the FKA concept.

The 2<sup>nd</sup> iteration of the FKA concept shows improved direct vision of both of the cyclists due to the lowered ride height that the concept exhibits.

The 3<sup>rd</sup> iteration of the FKA concept provides good visibility of the cyclists through the lower door window.

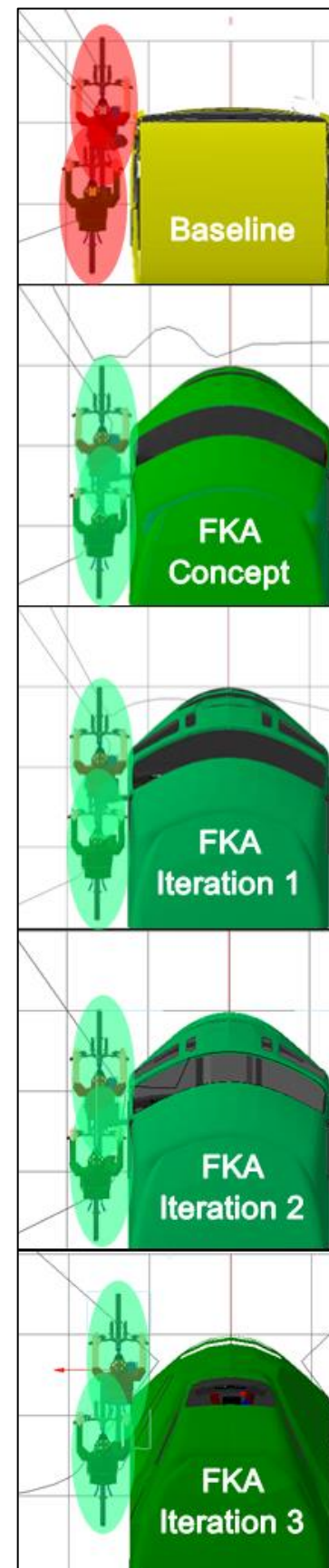

### 3.3.1.5 OFFSIDE (DRIVER SIDE) VISIBILITY – MOTOR VEHICLE

All vehicle models provide good direct vision of the car on the offside of the vehicle.



### 3.3.1.6 NEARSIDE (PASSENGER SIDE) VISIBILITY – MOTOR VEHICLE

The DAF XF obscures the vehicle on the near side at a distance of up to 2595mm away laterally.

The FKA concept obscures the vehicle on the near side at a distance of up to 1874mm away laterally.

The three iterations of the FKA concept all allow good direct vision of the vehicle through the lower passenger door windows.

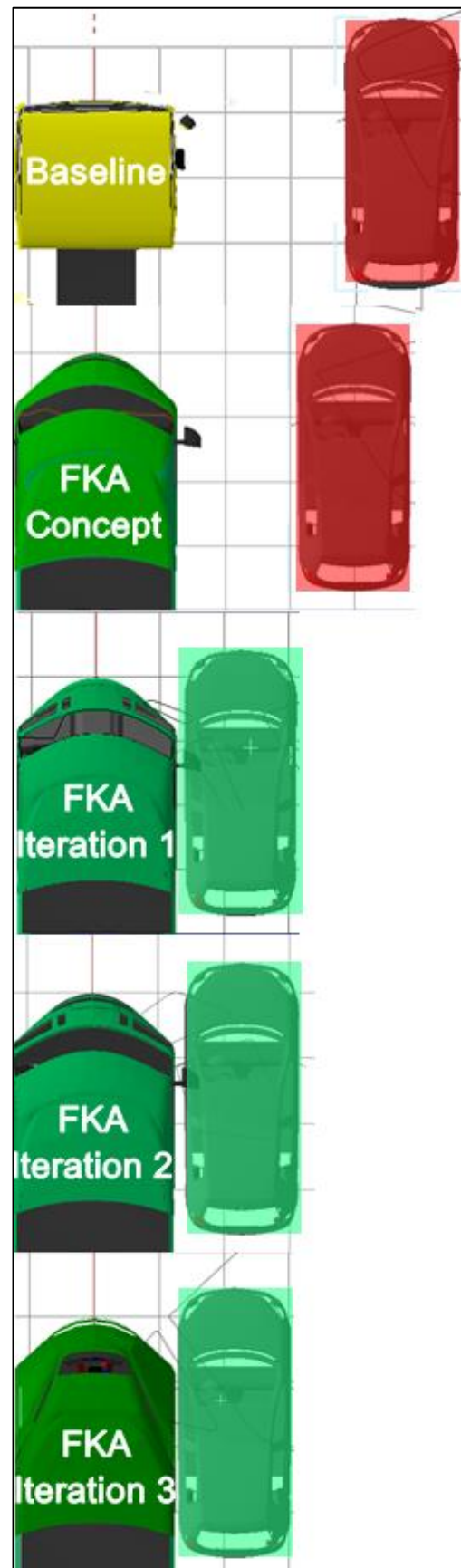



### 3.4 BLIND SPOT MAP FOR FKA CONCEPT ITERATION 2 – WITH ADDITIONAL WINDOW APERTURES AND REDUCED HEIGHT

Figure 145 shows the blind spot map for the FKA Iteration 2. The red areas show the blind spots around the vehicle on the ground plane. The blue areas show the blind spots around the vehicle at the ground plane +1755mm (50<sup>th</sup> %ile UK male head height). This particular concept provides excellent direct visibility in close proximity to the vehicle for VRUs.

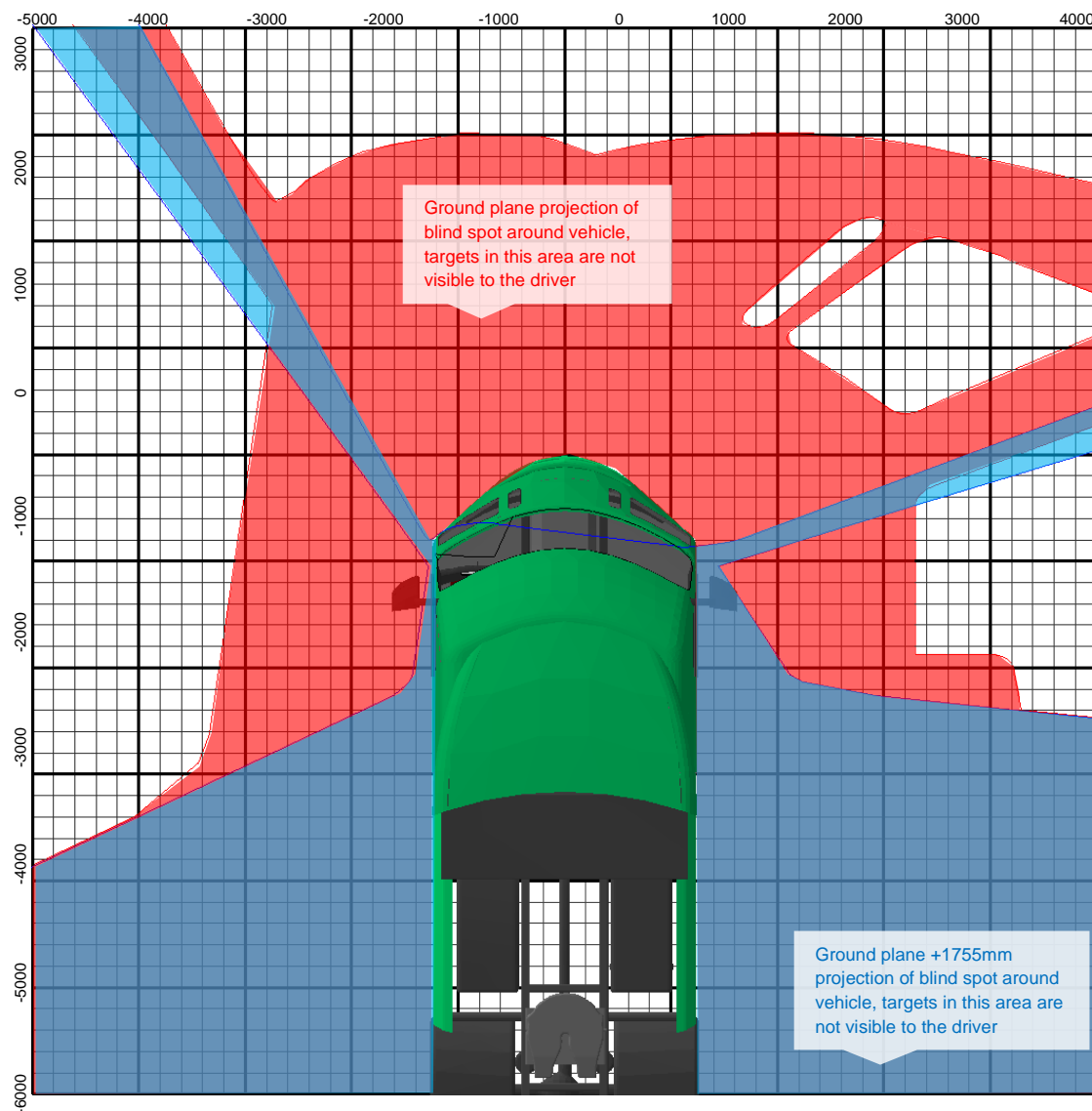

Figure 145. Blind spot map for FKA Iteration 2. Red areas show blind spots around the vehicle on the ground plane. Blue areas show blind spots around the vehicle at the ground plane +1755mm (head height for a 50<sup>th</sup> %ile UK male, equivalent to 63<sup>rd</sup> %ile German male, 72<sup>nd</sup> %ile French male, 26<sup>th</sup> %ile Dutch male)

## 4 DISCUSSION OF RESULTS AND DESIGN RELATED ISSUES THAT HAVE BEEN HIGHLIGHTED BY THE ANALYSIS

The process of performing the analysis and presenting the initial results to stakeholders has resulted in number of additional questions which are pertinent to the discussion regarding European truck design directions. These questions are;

1. What impact does the passenger seat and passenger have on the ability to use the additional side windows in FKA concept iterations 1 and 2?
2. In existing vehicles the dashboard structure contains electronic modules and other services. Can the proposed design for the reduced dash board size in concept iterations 1 and 2 include space for these vehicle components?
3. Would the removal of the dashboard structure in front of the passenger in concept iterations 1 and 2 reduce the safety of the passenger?

The following sections provide responses to these questions.

### 4.1 WHAT IMPACT DOES THE PASSENGER SEAT AND PASSENGER HAVE ON THE ABILITY TO USE THE ADDITIONAL SIDE WINDOWS IN FKA CONCEPT ITERATIONS 1 AND 2?

The benefits of an additional lower window in the passenger door has the potential to be reduced if a passenger is occupying the passenger seat. Manufacturer representatives for Scania and Volvo in the UK have been contacted to determine if there is data available on the proportion of goods vehicle journeys that involve carrying a passenger. No data was available but anecdotally, the carrying of passengers was considered to be rare apart from specific situations where more than one person occupies the cab such as the carrying of two drivers for exceptionally long journeys (e.g. across Europe) and situations where crew cabs are used such as those associated with fire engines. The issue of a passenger/passenger seat blocking the view through the lower passenger door window has been explored by adding a passenger seat to the 2<sup>nd</sup> iteration of the FKA concept vehicle in a location that is equivalent to the driver's seat, mirrored through the centre line of the vehicle i.e. the same offset from the side of the vehicle and the same fore aft adjustability. Figure 146 shows a passenger seat in the location that is equivalent to the rearmost lowest adjustment on the driver's seat. If a passenger seat were to be specified in this manner it would block part of the view obtainable through the lower passenger door window, and this situation is made worse when a passenger occupies the seat as shown in Figure 147. The situation can be improved for an empty passenger seat if that seat can fold up as shown in Figure 148.



Figure 146. A passenger seat has the potential to reduce the effectiveness of the lower passenger door window



Figure 147. A passenger occupying the passenger seat has the potential to further reduce effectiveness of the lower passenger door window



Figure 148. An unoccupied passenger seat can allow full view of the lower passenger door window if it is foldable

4.2 IN EXISTING VEHICLES THE DASHBOARD STRUCTURE CONTAINS ELECTRONIC MODULES AND OTHER SERVICES. CAN THE PROPOSED DESIGN FOR THE REDUCED DASH BOARD SIZE IN CONCEPT ITERATIONS 1 AND 2 INCLUDE SPACE FOR THESE VEHICLE COMPONENTS?

Figure 149 shows how additional dash structure can be added to allow for the location of electronic components and other services such as washer bottles, whilst retaining the improved vision benefits of the additional glazed areas below the windscreen on the passenger side.

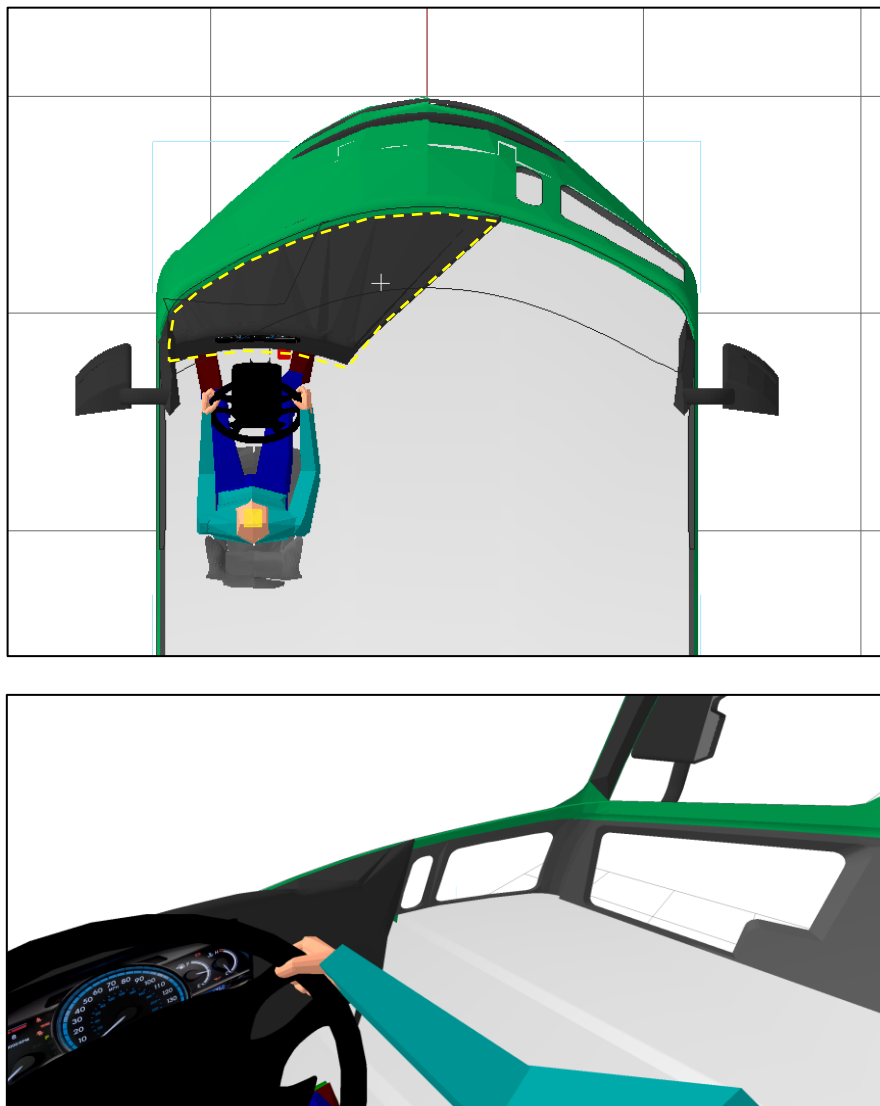

Figure 149. Additional dash structure has been added to illustrate that electronic components can be placed in front of the driver location

Figure 150 shows how the additional glazed areas below the windscreen on the driver side have been removed from the concept design. The driver side glazed areas do not add improved vision for the driver though this configuration would necessitate dedicated Right and Left hand drive vehicle cabs to be produced.

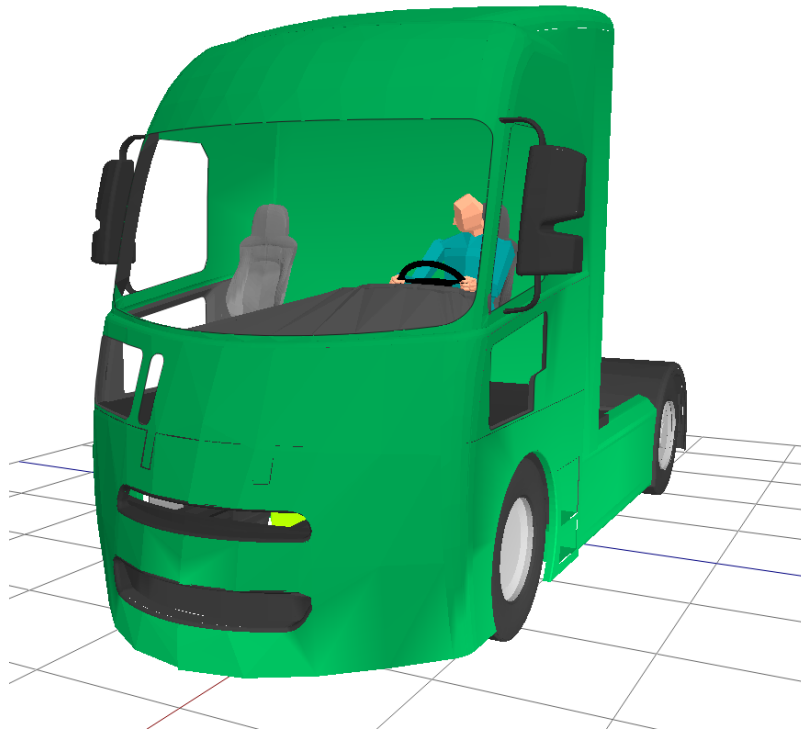

Figure 150. The window apertures below the windscreen in front of the driver have been removed as these add no improvement to direct vision

#### 4.3 WOULD THE REMOVAL OF THE DASHBOARD STRUCTURE IN FRONT OF THE PASSENGER IN CONCEPT ITERATIONS 1 AND 2 REDUCE THE SAFETY OF THE PASSENGER?

This question was raised with reference to the dashboard structure in front of the passenger seat in existing vehicles being used as a mounting location for SRS airbags. A review of manufacturer's vehicle specifications and discussions with manufacturer representatives highlighted that passenger air bags are not currently provided as standard fitment or as an option. The potential for the structure of the dashboard to add to the structural integrity of the vehicle cab is beyond the scope of the project.

## 5 SUMMARY OF FINDINGS

As has been highlighted in previous research<sup>10</sup>, existing vehicle designs exhibit considerable direct vision blind spots in front of and to the near (passenger) side of the vehicle. The analysis that has been illustrated in this report has showed that these blind spots can be improved for the specific tests that have been performed in this research through the design features of the FKA concept and the iterations of the concept that have been produced by the LDS team.

The FKA concept improves direct vision of vulnerable road users located at the centre of the vehicle front as the extended front effectively pushes the visual targets further away from the driver's eye point. The visibility to the two front corners of the FKA concept and the lateral visibility through the driver and passenger doors are still problematic in a manner that is similar to the issues identified with current real world designs as exemplified by the DAF XF.

The first iteration of the FKA concept removes the obscuration provided by the existing dashboard structure through the design of a compact instrument panel similar to those used in bus and coach designs. This iteration also improves direct vision to the nearside and front nearside corner of the vehicle through the use of additional glazed areas. The visibility of the offside front corner is still problematic.

The second iteration of the FKA concept is the most successful concept analysed, with good direct vision of all of the visual targets that have been defined in the research project. This is mainly due to the reduction of the driver's eye height by 230mm, combined with the additional glazed areas of iteration 1. This reduction of height has been shown to be possible through the configuration of an existing Scania vehicle with the result being a vehicle that has a reduced ground clearance. This means that the vehicle would have limited off road capabilities, but improved direct vision.

The more radical design of the third iteration of the FKA concept provided advantages to direct vision through improved lateral visibility even at the original height of the concept vehicle. However, this iteration also introduced new issues to the direct vision problem. The more forward location of the driver within the cab body combined with the dash board location and the location of the A-pillars in the narrower cab configuration provided additional blind spots to forward vision. The design would require further fine tuning to remove these limitations.

Therefore the project has shown that the potential to extend the front of category N<sub>3</sub> vehicles to include aerodynamic features has some benefit in terms of improved direct vision for the design that has been analysed, but that more radical design

---

<sup>10</sup> Cook, S. E., et al., 2011. [The development of improvements to drivers' direct and indirect vision from vehicles. Phase 2](#). Loughborough University. Report for Department for Transport.

solutions, such as lowering the drivers' cab, and adding glazed areas to the doors and below the windscreen bottom edge provide more effective solutions to the direct vision problem.