

Manufacturing Research, September 9-11 2014, Southampton Solent University,
Southampton, UK: Hampshire Press Ltd.

CUTTING TOOLS IN FINISHING OPERATIONS FOR CNC RAPID MANUFACTURING PROCESSES: SIMULATION STUDIES

Muhammed Nafis Osman Zahid
Mechanical and Manufacturing Engineering
Loughborough University
Loughborough
Leicestershire, LE11 3TU, UK
M.N.Osman-Zahid@lboro.ac.uk

Keith Case
Mechanical and Manufacturing Engineering
Loughborough University
Loughborough
Leicestershire, LE11 3TU, UK
K.Case@lboro.ac.uk

Darren Watts
Mechanical and Manufacturing Engineering
Loughborough University
Loughborough
Leicestershire, LE11 3TU, UK
D.N.Watts@lboro.ac.uk

ABSTRACT

CNC machining has been widely used in producing metal parts with high accuracy and reliable quality. A distinct process planning approach that utilizes an indexing device to hold the workpiece has extended CNC applications into the realm of rapid manufacturing (CNC-RM) processes. This study improves the implementation of this technology by providing a methodology for integrating the tools into finishing processes. It aims to enhance the process efficiency by minimizing the stair-casing effect of layer removal and so improve the quality of machined parts. In order to achieve this, finishing operations are executed using different types of end mill tools to cater for specific surfaces. Simulations are carried out to verify the method and implications. The findings indicate the advantages of the approach in terms of cutting time and the minimisation of excess volumes left on parts. Using different cutters for finish cuts improves the capabilities of CNC machining in rapid manufacturing applications.

Keywords: Finishing operations, Cutting tools, CNC machining

1 INTRODUCTION

In machining processes, it is crucial to ensure good surface finish quality as this will influence the performance of machined parts and productions costs (Davim 2001). Improving surface finish has become a major concern particularly in rapid manufacturing processes where the objective is to achieve final geometry directly. An approach developed to implement CNC machining for rapid applications uses an indexable device to hold a cylindrical workpiece on 3-axis milling machine, so that machining can be executed continuously without the need for any re-fixturing. Parts can be produced by machining in several orientations to cut all surfaces. One of the distinct features of this technology is a capability to remove material at very minimal depth of cut which produces fine and reliable surface finish. In order to optimize the process, roughing and finishing operations are carried out through several cutting orientations. Previous development had suggest roughing operations to be performed through four independent cutting orientations as this is proven to minimize overall machining time (Osman Zahid et al. 2013). Meanwhile, finishing operations are executed based on orientations proposed by visibility analysis that aimed to completely machine the parts (Frank et al. 2006). This study attempts to show that using different cutting tools in finishing operations can improve surface finish by minimizing the amount of excess volume left on parts.

Currently, a general approach is implemented in the selection of tools during finishing operations. Feature recognition tasks are avoided as this tends to complicate the process planning before the

machining starts. The previous approach recommended the smallest diameter tool to finish cut the part with the assumption that it would be able to reach all desired surfaces (Frank et al. 2004). Therefore, a flat end mill is most likely to be selected because it is suitable for machining $2\frac{1}{2} D$ layers determined from the visibility analysis. Moreover, adopting a single cutting tool in finishing operations managed to simplify the process planning tasks. Similar cutting areas are selected and used in all cutting directions. It is expected that this method preserves some accessibility to most of the features presented and completely cuts the part.

However, depending on a single cutter in finishing operations tends to limit the performance of CNC machine in producing quality parts. Several inefficiencies are identified during machining operations. First, due to the geometry of flat end mill cutters, a stair-casing effect is visible on part surfaces particularly on contours and non-flat regions. This effect still can be seen even if minimum cutting layer depths are adopted (Frank et al. 2002). Besides, using small cutting depths will definitely make the cutting time longer. Another limitation can be viewed by assessing the tool accessibility on part features. Analysis that focuses on machinability has resulted in some uncut material being left on part due to inaccessibility of the cutting tool (Li et al. 2006), and inevitably, this will affect dimensional accuracy. So far, there is no specific method has been developed to cater for the integration of tools integration for this rapid machining process.

2 METHODOLOGY

2.1 Cutting tools and surface classification

Basically, in the CNC-RM approach, finishing operations are executed through predetermined orientations and aim to shape the material completely. Hence, this process cuts the material to a very shallow depth to obtain a fine surface finish. Previous developments have implemented different cutting tools to finish cuts part built by welding process through layer deposition method (Akula et al. 2006). However, this approach utilized various type of tools and several surface categories. As cutting processes execute rapidly, this approach seems impractical as it tends to complicate the planning tasks. But, some modifications to minimize and eliminate irrelevant setups will help to adopt this method in CNC-RM processes.

In one particular cutting direction, surfaces contained on part can be classified as flat and non-flat surfaces. A flat surface is defined as a surfaces that is perpendicular to the cutting tool direction whereas the rest of the surfaces are categorized as non-flat surfaces. These classifications allow specific cutting tools to be assigned to machine the part effectively. Therefore, one orientation will perform up to two cutting operations if both type of surfaces are present. The first areas that will be cut are the flat surfaces using a flat end mill cutter. Then, the process continues by machining non-flat surfaces using a ball nose end mill. Based on Figure 1, assuming cutting starts at 0° direction, the tool is engaged with the workpiece from the ZC direction. In this particular direction, the dark areas represent flat surfaces that are perpendicular to the cutting tool direction. The first finishing operation is performed on this surface using a flat end mill tool. Then, the CNC machine replaces current tool with similar sized ball nose end mill. This tool is used to machine the other surfaces shown as light grey areas on the part.

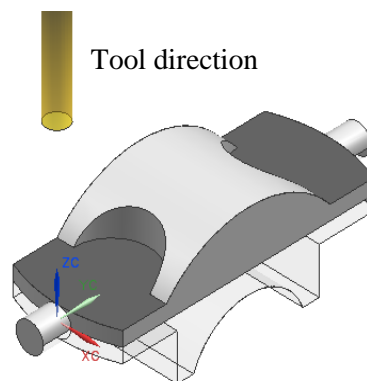

Figure 1: Classification of flat and non-flat surfaces in one cutting direction

Generally, there are three common end mill tools that differ based on the shapes of the tool tip. These include flat, bull nose and ball nose end mill. In this study, only two tools are selected to be utilized in finishing operations. A flat end mill is capable of machining plane surfaces with minimum scallop size compared to other tools (Ryu et al. 2006, Elber 1995). Therefore, this is exactly the right tool to cut the flat surfaces classified on parts. The second selection utilizes a ball nose tool to cater for non-flat surfaces. Based on previous studies, the capabilities of this tool in handling sculptured surfaces are proven and manage to produce high quality surface finish (Vijayaraghavan et al. 2009, Chen 2008, Chen et al. 2005, Elbestawi et al. 1997). Moreover, this tool can be easily guided to engage with part surfaces and produce simpler NC code for machining (Chen et al. 2008).

2.2 Machining and verification processes

Similar to a roughing operation, the levels of cutting in finishing operation are continued until the centre of cylindrical workpiece. However, this is applicable only if a flat end mill tool were used in the operation. In the case where both tools are used to cut the workpiece, the ball nose cutter requires extended cutting levels to completely remove the remaining material. This is critically important for a part that contains closed regions which only permit tool access in limited directions. Figure 2 visualizes the situation where there is remaining material left due to the insufficient cutting levels. Therefore, the cutting levels for a ball nose tool are extended until the centre of workpiece reach side of the cutting tool. The simulation tasks were carried out with NX 7.5 software using the manufacturing application. A series of machining operations were created and the software used to estimate machining time to fabricate the parts. In order to calculate the excess volume left, the simulation work was extended by using CGTech VERICUT ® 7.2.3. Recently, this software has been interfaced to NX which provides convenient access to run the simulation once operations have been created.

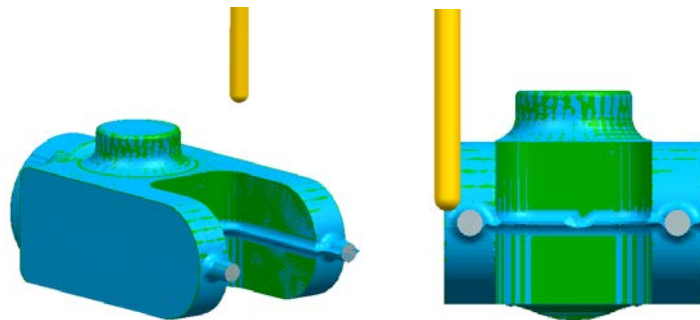

Figure 2: Remaining uncut materials left by ball nose end mill tool

3 RESULTS AND DISCUSSION

The simulation studies have been conducted using different models including drive shaft, knob, salt bottle and toy jack models. To visualize the implications of the suggested approach, similar cutting operations relying totally on the use of a flat end mill tool is developed. Therefore, Approach 1 was based on a process that utilized a single flat end mill whereas Approach 2 represented the method developed in this study that integrates different cutting tools. There are two main evaluation criteria that are based on machining time and excess volume. Table 1 and Table 2 summarize the results produced from the simulation studies. Machining time is recorded in (hour:minutes:seconds) format and volume information is in mm^3 . The amount of material removed from the workpiece is presented as machined volume in the tables. Part and stock volumes are calculated earlier based on the virtual models. It is apparent from these tables that there are significant differences between Approach 1 and 2. Out of the four models, three indicate a reduction of cutting time by implementing the approach developed in this study. Interestingly, all models gained minimum excess volume once different cutting tools were used in finishing operations. Assigning specific tools to particular surfaces, the ranges of excess volume reduce from 0.9-3.3% down to 0.7-1.6% of the total part volume.

3.1 Implications for machining time

Data gathered in the tables clearly indicate the benefits of implementing different cutting tools in CNC-RM processes. The majority of the models studied show a decreasing trend of machining time compared to a single tool approach. Finishing cutting times contribute most of the savings. This signals the effectiveness of cutting tools removing material on assigned surfaces. Depending on part geometries, cutting times differ from 2 minutes up to 11 minutes. For example, results for the drive shaft model in Table 1 indicate that the current method in Approach 2 manages to reduce machining time by about 11 minutes compared to Approach 1. Nonetheless, some models show only a small reduction of machining time such as toy jack model. In this model, only ball nose tools were used as only non-flat surfaces were present on the part. For a large production run, this reduction might still be significant in minimizing cost and time. Oppositely, the knob model indicated slightly longer machining time compared to Approach 1. The variety of flat and non-flat surfaces present on the part are possibly the main factors influencing cutting time.

Table 1: Results for drive shaft and knob model

Criteria \ Approach	Drive shaft		Knob	
	Approach 1	Approach 2	Approach 1	Approach 2
Machining time	04:13:20	04:02:35	03:50:09	03:52:40
Finishing time	02:38:30	02:28:39	02:44:49	02:27:16
Non-cutting time	00:16:58	00:16:08	00:09:11	00:10:20
Roughing time	01:17:52	01:17:48	01:15:04	01:15:04
Cutting orientations	90°-180°-280°-0°-32°-180°-0°	90°-180°-280°-0°-32°-180°-0°	90°-180°-280°-0°-180°-45°-315°	90°-180°-280°-0°-180°-45°-315°
Machined volume	150273.23	150432.83	112946.97	113203.60
Current part volume	53244.05	53084.45	21660.63	21403.91
Excess volume	514.82	355.22	527.99	271.27

Table 2: Results for salt bottle and toy jack model

Criteria \ Approach	Salt bottle		Toy jack	
	Approach 1	Approach 2	Approach 1	Approach 2
Machining time	04:32:02	04:23:26	03:25:22	03:21:42
Finishing time	02:38:44	02:29:33	02:16:04	02:12:44
Non-cutting time	00:11:57	00:12:28	00:14:06	00:13:44
Roughing time	01:41:21	01:41:26	00:55:12	00:55:12
Cutting orientations	0°-90°-190°-270°-45°-180°-270°	0°-90°-190°-270°-45°-180°-270°	50°-140°-240°-320°-49°-140°-228°-320°	50°-140°-240°-320°-49°-140°-228°-320°
Machined volume	76676.80	76845.85	109662.15	109792.30
Current part volume	34499.39	34330.33	7769.86	7639.71
Excess volume	417.56	248.5	252.74	122.59









3.2 Volume of excess materials

Previous studies validated the capabilities of ball nose cutters on sculptured surfaces. Hence, assigning the tools based on flat and non-flat surfaces manages to minimize the excess volume on parts. Surprisingly, simulation results consistently indicate that excess volume was reduced for all models studied. Some models show a considerable reduction. For instance, excess volume for the knob model decreases dramatically from 527mm³ down to 271mm³. In CNC machining, uncut materials can be reduced by modifying cutting parameters in finishing operations including depth of

cut, number of passes etc. However, in the CNC-RM approach, all these parameters remain constant except for the type of cutting tools used. Therefore, the achievements in this study show that the main factor that influences the results is due to the cutting tools combination.

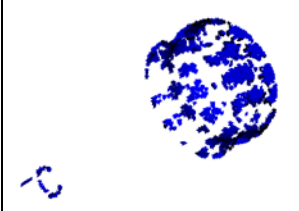
Furthermore, the implications can be visualized by analysing the material distribution diagram as shown in Table 1. Comparing Approach 1 and 2, it can be seen that most of the excess materials on non-flat surfaces of the part have been reduced. This indicates that the ball nose cutter effectively minimizes the stair-casing effect. Keeping the flat end mill cutter to machine flat surfaces is useful in overcoming the weakness of ball nose tools. However, attention is required while shaping the sacrificial supports using a ball nose cutter. In the case where the support is connected to flat vertical surfaces, cutting tools have limited access to the machining area. Therefore, fillet shapes tend to form on the edge of the support and part. This effect also appears if flat end mills were used but with only a moderate excess material. Currently, a strategy to use a small tool manages to minimize the effect. Overall, volume data gathered from this study has revealed the level of quality that can be achieved by integrating cutting tools in finishing operations.

Table 3: Excess materials distribution based on studied models

Drive shaft		Knob	
Approach 1	Approach 2	Approach 1	Approach 2
			
Salt bottle		Toy jack	
Approach 1	Approach 2	Approach 1	Approach 2
			

4 CONCLUSION

This simulation study has revealed the advantages of using different cutting tools in finishing operations particularly for CNC-RM processes. The present study was designed to improve part quality by reducing uncut material left after completion of machining. Generally, using different tools to cater for flat and non-flat surfaces is an effective way to minimize excess volume. Furthermore, machining times also can be reduced depending on part geometries. In order to visualize the implications, the results were compared to a previous method that adopted a single flat end mill tool throughout the cutting operations. Distinctly, the comparisons show the method developed in this study are capable of enhancing part quality and appearance. Further studies could focus on integrating this approach into CNC-RM process planning. The surface classification task needs to be handled carefully so that it will not complicate the planning task. Moreover, further verifications are still required through experimental study so that real models can be fabricated and analysed completely.

REFERENCES

- Akula, S. and K. Karunakaran. 2006. Hybrid adaptive layer manufacturing: An Intelligent art of direct metal rapid tooling process. *Robotics and Computer-Integrated Manufacturing*, **22**(2):113-123.
- Chen, J., Y. Huang and M. Chen. 2005. A study of the surface scallop generating mechanism in the ball-end milling process. *International Journal of Machine Tools and Manufacture*, **45**(9):1077-1084.
- Chen, T. and Z. Shi. 2008. A tool path generation strategy for three-axis ball-end milling of free-form surfaces. *Journal of Materials Processing Technology*, **208**(1):259-263.
- Davim, J. P. 2001. A note on the determination of optimal cutting conditions for surface finish obtained in turning using design of experiments. *Journal of Materials Processing Technology*, **116**(2):305-308.
- Elber, G. 1995. Freeform surface region optimization for 3-axis and 5-axis milling. *Computer-Aided Design*, **27**(6):465-470.
- Elbestawi, M., L. Chen, C. Becze and T. El-Wardany. 1997. High-speed milling of dies and molds in their hardened state. *CIRP Annals-Manufacturing Technology*, **46**(1):57-62.
- Frank, M. C., S. B. Joshi J and R. A. Wysk. 2002. CNC-RP: a technique for using CNC machining as a rapid prototyping tool in product/process development, *Proceedings of the 11th annual industrial engineering research conference, Orlando, Florida. May 2002*, Citeseer, 19-22.
- Frank, M. C., R. A. Wysk and S. B. Joshi. 2006. Determining setup orientations from the visibility of slice geometry for rapid computer numerically controlled machining. *Journal of manufacturing science and engineering*, **128**(1):228-238.
- Frank, M. C., R. A. Wysk and S. B. Joshi J. 2004. Rapid planning for CNC milling-A new approach for rapid prototyping. *Journal of Manufacturing Systems*, **23**(3):242-255.
- Li, Y. and M. C. Frank. 2006. Machinability analysis for 3-axis flat end milling. *Journal of manufacturing science and engineering*, **128**(2):454-464.
- Osman Zahid, M. N., K. Case and D. Watts. 2013. Optimization of Roughing Operations in CNC Machining for Rapid Manufacturing Processes, *Proceedings of the 11th International Conference on Manufacturing Research*, Cranfield University Press, 233-238.
- Ryu, S. H., D. K. Choi and C. N. Chu. 2006. Roughness and texture generation on end milled surfaces. *International Journal of Machine Tools and Manufacture*, **46**(3):404-412.
- Vijayaraghavan, A., A. M. Hoover, J. Hartnett and D. A. Dornfield. 2009. Improving end milling surface finish by workpiece rotation and adaptive toolpath spacing. *International Journal of Machine Tools and Manufacture*, **49**(1):89-98.