

Rolling Stock Technology for the Future

Roger Goodall and Christopher Ward

School of Electronic, Electrical and Systems Engineering, Loughborough University, UK

[r.m.goodall/c.p.ward@lboro.ac.uk](mailto:r.m.goodall@c.p.ward@lboro.ac.uk)

Abstract

The paper presents a vision for future rolling stock with a timescale of 30-50 years to identify the key changes that are likely to be influential, in particular to meet the challenges associated with the UK's ambitious technical strategy. Overall it suggests the authors' vision for future rolling stock, not necessarily as a perfect prediction, but certainly to highlight the main possibilities.

Introduction

Railways in Europe and elsewhere in the world have undergone substantial change in the last two decades, and now they are not only an essential part of national infrastructure but also contribute significantly to a sustainable future. However in the UK in particular there is a general acceptance that both the cost to government in terms of subsidy and the price to passengers have risen disproportionately [1]. The railway's "green credentials" are well founded but are under challenge from competing transport modes, especially the improvement in automobiles, and the customer's expectations in terms of quality and reliability of service inevitably rise as time goes on, and so in both the UK and across Europe there are ambitious technical strategies aimed towards meeting these various challenges [2, 3].

In order to consider possible technological changes that might address these issues, the following questions will be addressed:

- Which are the key engineering sub-systems of today's railway vehicles that are most likely to undergo significant change?
- What technologies are either already happening or on the horizon that will determine how future railway vehicles might look?
- How might these vehicles operate within railways of the future?
- Are there any "competitive" ground transportation technologies (e.g. Maglev) that might have a significant impact upon railways?

A particular focus of the paper will be to consider the concept of "Design for Control", i.e. a fundamental re-thinking of the design possibilities. This needs to be considered more thoroughly in future railway vehicle design due to the system level benefits it can bring, the true benefits of which can only be properly assessed by taking a systems wide view.

If one looks back (say) 40 years to the 1970s there have been a number of substantial changes that were not envisaged (or more generally dismissed with little evidence), for example:

- Tilting train technology had been demonstrated at the time but was not used operationally as there was uncertainty at the time about its value. However it is now an established, mature technology [4]
- A.C. electric traction with power electronic drives had been considered but discounted on the basis that it was not economic. Of course is now the traction system of choice for modern trains [5]
- The now ubiquitous use of computer bus architectures to transmit information throughout the train was not even anticipated at the time [6].

The message from this retrospective is that it's difficult to make predictions of the future, particularly when looking 40-50 years ahead, but also that too much caution is not appropriate.

Railway vehicle technology – overview of future possibilities

In order to provide a framework for answering the first question above, one way of breaking things down is by function, and there is a European Standard [7] that lists a number of top level functions to be provided:-

- Carry and protect passenger, train crew and load
- Provide appropriate conditions to passenger, train crew and load
- Provide access and loading

- Connect vehicles and/or consists
- **Provide energy**
- **Accelerate, maintain speed, brake and stop**
- Provide train communication, monitoring and control
- **Support and guide the train on the track**
- Integrate the vehicle into the complete railway system

An alternative system breakdown which was developed during the EC ModTrain project has the following first-level list of engineering sub-systems:

- Car body, fittings, interiors and lighting
- **Bogies and running gear**
- **Power and propulsion system**
- Auxiliary systems
- **Braking system**
- On-board vehicle control
- Passenger Information System
- Communication systems
- Cabling and Cabinets
- Door System
- HVAC
- **Tilt system**
- Couplers

Of course all the functions and sub-systems are important, but this paper is focussed upon aspects of rail vehicle technology that will have a fundamental effect upon the mechanical configuration of the vehicles, and so the authors have made a judgement to consider those that are highlighted in the lists above. The following sub-sections provide an overview of these possibilities.

Power and propulsion system

Electric trains are already widely available and technologically mature (unlike the automobile industry's aspirations regarding electric cars). They are in fact in an excellent position to take full advantage of progressive decarbonisation of the national energy generation facilities and therefore well-placed to maintain their position as the most energy-efficient form of ground transportation.

Over the last two decades developments in power converter technology, both in terms of the maximum power that can be handled and the mass and volume densities, have enabled a fundamental transition from DC to AC motors which are lighter, more compact, more efficient and more reliable [5]. It has also led to the transition from locomotive-hauled trains to trains with distributed traction, i.e. where most or all vehicles have their own traction equipment, albeit controlled in unison through the train.

The capability to provide braking using the electrical traction motors and thereby recover the kinetic energy is intrinsic, but full exploitation of regenerative braking relies upon guaranteeing the availability and receptivity of the trackside supply, which is why many trains carry a resistor to dissipate the energy. It is anticipated that developments in energy storage technology, whether in the form of batteries, super-capacitors, flywheels, superconducting magnetic energy storage (SMES), etc., will lead to devices that are usable on trains in terms of energy densities (both mass and volume), and this will enable further improvements in energy efficiency.

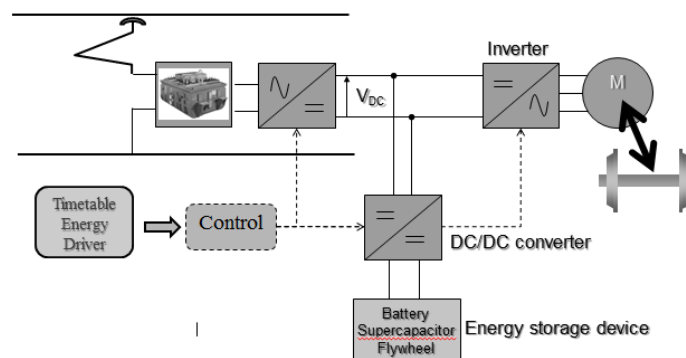

Figure 1 Traction system with energy storage and optimised energy management

Energy storage combined with future developments in power converters will therefore provide the opportunity to optimise the energy management by altering the flow of energy between the trackside power supply, the traction motors and the energy storage devices, including accommodating the need to both maintain the timetable and minimise energy via driver advisory systems – see Figure 1. There is also a major benefit for non-electric trains, whether these are diesel-hydraulic or diesel-electric. In

fact for these vehicles there is no possibility of returning any of the kinetic energy to the trackside supply, so the benefits in terms of improved efficiency are even larger than for electric trains.

Active suspension systems

There have been many theoretical studies of active suspensions and a small number of full-size experiments, some of which go back to the 1970s. However, with the exception of tilting systems, today's suspension systems remain almost exclusively passive, i.e. utilizing purely mechanical elements such as springs and dampers. There are nevertheless many benefits that may arise and the more significant long term benefits are explained in the next section "Design for Control".

Tilting technology is a form of active secondary suspension which provides an improved vehicle response in curves. Although it can improve the ride comfort for passengers, it is principally used to enable higher speeds through curves and is now a well-established, mature technology because it reduces journey times without needing substantial changes to the track alignment.

Active secondary suspension control can also be used to give a better response to the track irregularities, and hence to improve the ride quality on straight track. However, although this has been practically demonstrated to give large improvements in ride quality (typically halving the accelerations experienced by the passengers), apart from some very limited examples it has not seen widespread use. This seems to be because ride quality on rail vehicles is "good enough", and so the business benefits do not justify the extra cost and complexity.

However the current trends in tilting control help to point the way towards the long term prospects for active suspension technology, because some of the newer tilt system controllers are aimed towards integrating feedback signals from the train itself with information from a track database which holds all the information about the curves etc. [8]. In the longer term this trend could provide "perfect" tilting performance, and ensuring the accuracy of the track data and synchronising it with the train position is the subject of current projects aimed towards mapping and locating trains accurately. This approach will also enable further improvements in what can be achieved via other forms of active secondary suspensions because the intended track alignment can be fed electronically into the suspension controller, meaning that the suspension has the capability to isolate fully from the irregularities (subject of course to there being sufficient suspension travel to accommodate the maximum size of the irregularities).

Braking system

The standard railway braking system utilises pneumatically-actuated friction brakes, sometimes onto the tread of the wheel but for high speed trains onto separate wheelset-mounted discs. Other techniques that act directly on to the track have been considered, for example using eddy currents or friction track brakes, but these bring substantially higher mass to the bogie, although they may help to mitigate the problems of low adhesion conditions.

For the future there is a desire to remove pneumatic systems from railway vehicles because the reservoir and compressor are bulky and heavy, and electro-mechanical brake actuation technology is a natural option. The tricky part is finding an effective solution that accommodates the full requirements, especially those related to safety, e.g. the brakes must go on when the power is lost, and although various manufacturers have investigated possibilities, so far there has not been a commercial solution.

Given the aforementioned developments in propulsion control and the ability to recover the train's kinetic energy electrically, in the longer term friction braking systems may become less of a necessity, the challenge being to achieve high-integrity effective braking using the traction system down to zero speed, and also to provide a parking brake electrically.

More- and all-electric trains

In aerospace there is growing trend towards more-electric aircraft, and eventually this may lead to all-electric aircraft. The latest Boeing 787 "Dreamliner" is without doubt a significant indicator of this trend, with electrical engine and auxiliary power unit starting, electric wing ice protection, electric air conditioning and cabin pressurisation, electrical brakes and electrically-driven hydraulic pumps. To accommodate this there is a highly expanded electrical supply system from the engine generators, and overall the change will reduce mechanical systems complexity by more than 50% compared to older aircraft, with elimination of pneumatic systems as a major contributor.

Automobiles are following similar trends, not only via the hybrid and electric vehicles that are becoming increasingly common, but also in terms of the vehicle systems: electric braking, electric power steering etc. are under serious development, and so to remain competitive railways need to understand how this can affect railway vehicles [9]. Possible features of future all-electric trains are likely to be

- No pneumatic air supply
- Alternative to air-spring suspension elements
- Electrical brake actuators
- Magnetic track brakes
- Braking solely through the traction system (i.e. no friction brakes)

Some of these are more difficult to achieve than others, but the overall benefits in terms of mechanical complexity could be profound and the list therefore provides an important target for railway engineers.

Railway vehicles – “Design for Control”

A recent feasibility study funded by RRUKA/RSSB [10] [11] was charged with investigating the possible combinational benefits of using advanced concepts of mechatronics in a new generation of rail vehicles. The fundamental thesis of the project was that “design for control” is an axiom already extensively employed in the aerospace [12] and automotive industries [13] that has proven highly beneficial in terms of system performance benefits but also in reducing unit purchase costs and shrinking maintenance burdens. An example of this thinking is the high performance relaxed stability Eurofighter Typhoon [14] that wouldn't have been possible with a purely mechanical design.

In the railway industry, active control for vehicle suspensions has been used in a sparse manner, and generally as a performance improvement measure for primarily passive systems, e.g. tilting control for increased train speed on curves (Pendolino, X2000, etc.), and lateral vibration control for improved passenger comfort on the series E2-1000 and E3 Shinkansen [15]. These are active “add-on” subsystems to passenger vehicles where the design thinking has converged on a standard design: two bogies per vehicle; each with two wheelsets; and two related passive stages of suspensions. There is a lack of in-depth understanding of the broader benefits for both vehicle design/architecture and extended impact on rail infrastructure that could be brought about by this concept of “design for control”.

The following sections contains a proposal for how techniques from literature (and more speculative ideas) can be drawn together to create a potential holistic end point design. This is followed by quantification of how this type of vehicle can create ‘track friendly’ guidance and some macro financial understanding of the long term benefits, plus a potential implementation plan.

Proposal for a railway vehicle of the future

There has been a substantial body of work in academia and research intensive parts of the rail industry that have postulated the potential of using ‘active control’ in mechanical designs, with an extensive literature review summarising this in [10]. Mostly however these have been proposed as single entity additive concepts or as additions to improve existing passive systems (with the exception of the work by DLR in Germany on the Next Generation Train (NGT) [16] and the European Mechatronic Train project [17, 18, 19] such as: tilt control; actively-controlled independently-rotating wheelsets; active pantograph uplift control; and advanced condition monitoring.

Figure 2 is a representation of what a mature rail vehicle with the concept of “design for control” at its core could look like. This concept is not far removed from the rail vehicles of today with the thinking constrained by the need to: travel along steel tracks; fit within a reasonable loading gauge; a full vehicle is still made up of a number of components; and that electrical energy for traction is collected from overhead line equipment. What is being proposed here is how the concept from the Victorian age can be manipulated to generate economic and societal benefits from contemporary technology and concepts.

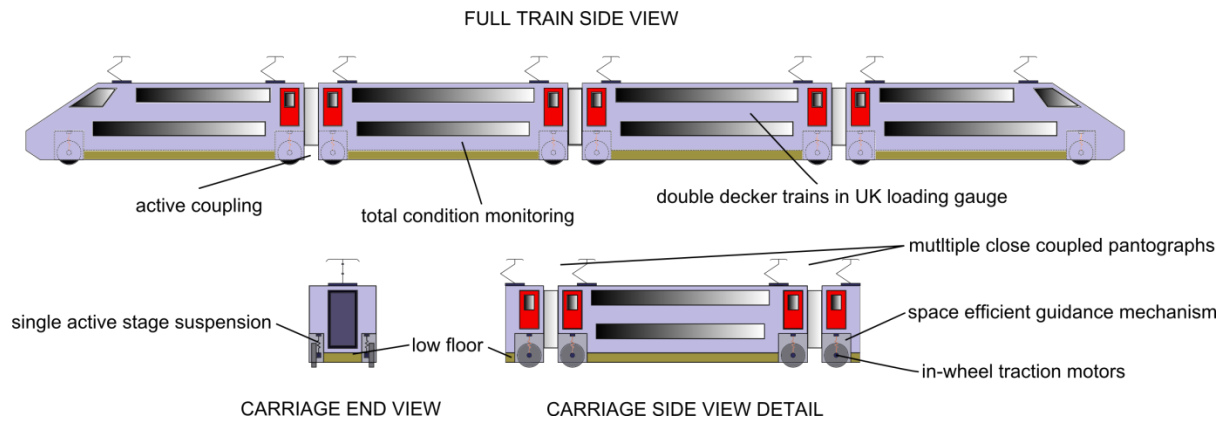

Figure 2 Concept for a full mechatronic train

The proposed vehicle has a number of key features. Individually they can create system improvements but it may be that the true benefit is realised with the concepts in combination. Also highlighted below is that these concepts should not be thought of in terms of benefit for the vehicle, but for the whole rail system. Justification on this level creates a far more compelling incentive for 'design for control'.

- **'Bogie-less' operation:** *two decoupled actively guided wheelsets per vehicle; flangeless wheels; single stage 'active' suspension; and in-wheel traction motors*
 - Active guidance reduces track wear and opens up the benefit of eliminating the mechanical trade off constraint between straight line stability and curving performance. Flangeless wheels would allow operation through simple fixed track infrastructure. A single stage mechatronic suspension has shown via simulation to be possible [20] and can: maintain ride quality similar to that of two-stage suspension; reduce mass; save space; and avoid exciting flexible vehicle body modes. In-wheel traction motors provide further space savings in this critical area and can be used for torque vectoring guidance.
- **Low floor carriages**
 - Clever thinking on packaging may allow two-floor operation in the UK's small loading gauge or make more space available for goods carriage.
- **'Total' condition monitoring**
 - Advanced processing can be used to give a true indication of the system condition. This is due to making efficient use of the multiple sensors required for the actively controlled systems. This sensing could also be used to feed into adhesion dependent braking. If the adhesion level is known the spacing between vehicles can be varied to make the most of the available adhesion profile and provide a useful improvement in the capacity available on existing lines [21].
- **Active coupling**
 - Removal of physical couplings between the vehicles would allow better aerodynamic properties through reduced vehicle gaps on the straight track whilst allowing suitable articulation through curves. It also opens up the possibility of vehicles combining and even separating en-route.
- **Multiple closely coupled pantographs**
 - Active uplift control of pantographs means that trailing pantographs are not disturbed by induced standing waves created by the leading pantograph. It also makes the previously-mentioned active train coupling possible.
- **Autonomous operation**
 - Full automation potentially allows for safety, operational and capacity benefits. This is the current trend in the aerospace and automotive sectors where in the former there is almost tacit acceptance from passengers that the pilot no-longer flies the aircraft.

Quantification of mechanical benefits

The focus for the dynamic study was drawn on the control possibility that would provide the largest transformational systems benefit; that of active guidance and stabilisation. The modelling consisted of: creating benchmark passive vehicle models; creating a number of active solutions; and testing these on representative sections of straight and curved track to determine effects on creep forces and vehicle body accelerations.

The benchmark vehicle is modelled as a single carriage of a typical multiple unit used in the UK. Further details relating to what is described here can be found in [10]. This is a four axle, two bogie design, with typical contemporary thinking for the suspension layout. Three vehicles were created at 100%, 75% and 50% mass so that the effects of weight 'shedding' could be quantified.

The mechatronic vehicle was selected to be two-axle with a single stage of suspension. This vehicle configuration is mechanically simpler and lighter than the benchmark vehicle. The bogies are deleted and the wheelsets are mounted onto the vehicle body via the springs and dampers in the lateral and vertical directions, with an actuator providing yaw torque to the 'axles'. The parameters for this vehicle scheme are based upon assumptions of the current trends of vehicle development around the world. This is mainly highlighted by vehicles such as the Japanese Shinkansen series being approximately half the mass per passenger compared to equivalent British vehicles [22]. Two control algorithms were developed: the first with a realistic sensor set as feedback; and the second with full state feedback to provide a benchmark of how good the control could be.

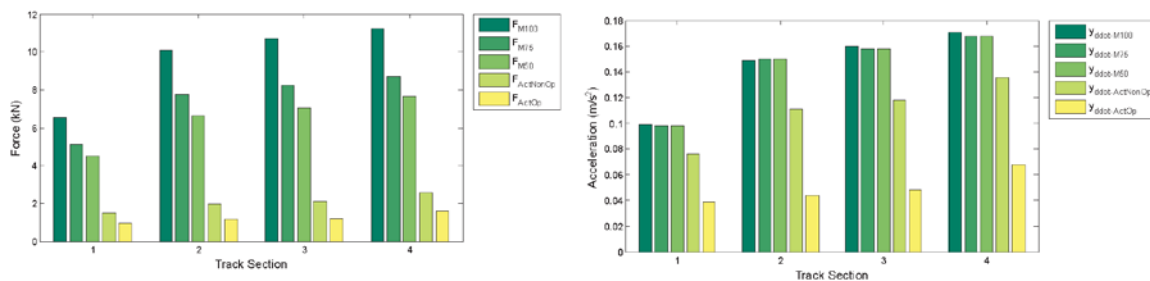

Figure 3 Force and lateral acceleration comparisons for passive vehicles of 100%, 75%, and 50% mass against actively steered vehicle with controller fed from realistic sensors and full state over 4 sections of straight track

Figures 3 draws together the average values of the contact forces and lateral acceleration experienced on the four sections of representative straight track by the five vehicles, with a conicity $\lambda=0.2$. Conclusions from this are

- A reduction in weight with the two stage suspension vehicles results in a reduction in contact force. It is noteworthy that the reduction introduces no improvement in ride quality.
- The introduction of active suspension can be seen to outperform the traditional suspension design methods both in terms of a reduction in contact force and in terms of ride quality. In comparison to the 50% mass baseline vehicle, a reduction of creep force of around 20% of the original value with a non-optimal controller up to around 30% to an optimal controller.

These trends are also repeated for differing conicity levels and when the vehicles are traversing curves.

Financial benefits

Any engineering changes suggested by this project were required to be evaluated in terms of their cost impact. It proved difficult in a number of areas to get definite quantitative information due to commercial boundaries and the complexity of the systems interactions. Benefits in terms of capital cost reductions are hard to quantify, and in the short term the mechatronic bogie may actually increase the purchase cost for early adopters. However in the longer term these costs would reduce as designers and engineers become used to the systems integration possibilities of designing in such systems.

The true benefits come in terms of the running costs (track damage and electrical energy). The level of longitudinal creep forces of the guidance mechanism can be greatly reduced through mechatronic systems opening up the possibility of 'track friendly' trains. It is postulated that this will also be accompanied by a reduction of the overall mass of vehicles due to the simplified and space efficient

mechanical design possibilities. Using today's cost modelling this means a reduction in track access charges and reduced use of electrical energy that could total to £300m for a fleet of vehicles over a 30 year life span (full details of the assumptions used can be found in [10]).

Maintenance and incident cost analysis proved more challenging in a quantitative sense but qualitative benefits can be shown from the near universal adaptation of the mechatronic ideas and condition monitoring in other transport sectors. This is already being adapted in rail.

Implementation

It is realised that the deployment of this technology may be initially fraught in today's environment where safety qualification of new technology is intensely difficult and driven by decades of hard won and painful experience. The railway industry's conservative outlook is not unique. In aerospace 'fly-by-wire' is currently considered the only method by which to design flight controls for both high-performance military fighter jets and civilian airliner applications. This is now proven technology that is used for performance, economic and safety reasons. However when first proposed a substantial component of the aerospace design community claimed that the concept would never work due to performance, economic and safety reasons [23]! The aircraft industry's steady adoption of this technology was due to a number of key champions proving the benefits of this concept over more than a decade. This iterative proving method persuaded enough key engineers to provide a critical mass of positive opinion to diminish to effect of the doubters.

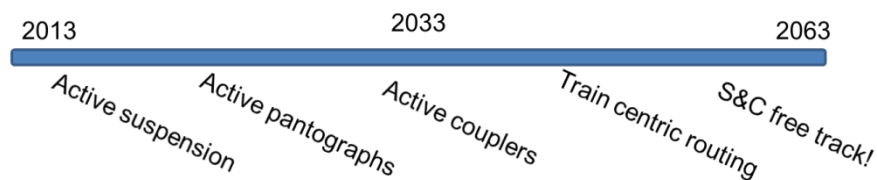

Figure 4 Mechatronics adaptation timeline

A similar approach will likely be needed in the rail sector. Figure 4 is a simplistic (and probably optimistic) estimation of how the technology could be adopted if the industry pursued this as a common agenda.

- **Stage 1 - Vehicle adaptations** There will inevitably be a transition period, as such the mechatronic vehicle concepts would need to work on existing infrastructure. The element to adopt first would be active single stage of suspension and the actively guided independently rotating wheelsets. This would bring many benefits in terms of capacity within the vehicle and the wear impact upon infrastructure.
- **Stage 2 - Command and control adaptations** Once a critical level of vehicles adapted to the new technology are operational their full potential can begin to be realised such as: driver-less operation; vehicle based route selection; vehicle co-operation/planning; and platooning of vehicles for energy conservation.
- **Stage 3 - Infrastructure adaptations** The changes up to this stage could essentially be achieved through application to existing infrastructure. The vehicle centric route selection opens the possibility of fixed infrastructure with all the associated maintenance and operational benefits.

The authors therefore see no technical impediment to the application of this type of technology. What is more critical is winning the financial argument of proving the business case and demonstrating that a long term investment in these ideas will provide a systems-wide benefit to all interested parties. How this would work with today's fragmented industry in the UK is uncertain.

Competitive technologies?

Ground transportation has for many years excited the interest of scientists, engineers and the general public, and stimulated many ideas that are seen as competition for conventional wheel-on-rail. This section makes comments upon two such propositions, one well-developed technically and the other an example of a very futuristic concept.

Maglev

Although Maglev remains an interesting possibility it's notable that, despite the revolutionary vision for the technology when serious development started back in the 1960s and 1970s, its impact upon high

speed transportation remains marginal. Maglev is in fact a family of technologies rather than a single solution, and there are two “main contenders”, albeit with a number of variants. The first is the Electro-Magnetic System (EMS) which uses controlled iron-cored electro-magnets providing a force of attraction to a steel rail, and the second is the Electro-Dynamic System (EDS) which has powerful, uncontrolled air-cored superconducting magnets that interact with conducting elements on the track (coils or aluminium sheets) to produce a force of repulsion when the train is moving.

The only operational high speed Maglev system is the EMS system based upon the German Transrapid [24]. It operates at over 400 km/h from Shanghai’s Pudong Airport to the outskirts of the city, a distance of 30km which in reality is too short for such a system. At one stage it was going to form the basis of a new line from Shanghai to Beijing, but the Chinese focus has now turned strongly towards high speed rail, and it recently published a vision for a global network based upon railways, not Maglev [25].

The other major development is an EDS system which the Central Japan Railway has developed. There is a 43km test line at Yamanashi which operates 550km/h vehicles, and the company has committed to Maglev for the new Chuo Shinkansen in Japan from Tokyo to Osaka, expected to be operational in 2027 [26].

The problem is that the early dreams for Maglev of having low noise and vibration and mechanical simplicity whilst being efficient, lightweight and cheap have generally not been realised [27]. It seems therefore that, despite Maglev’s capability for significantly higher speeds, it is not yet in a position to challenge conventional railways. A transformative scientific discovery such as practical, room-temperature superconductors could change things, although such a discovery would also have profound benefits for any electrically-powered transport system.

The “Hyperloop”

To go even faster than the speeds envisaged for Maglev requires some means of reducing the propulsion forces, and the Hyperloop [28] is an example of a concept aimed towards operation at 1130 km/h which proposes running in a partially evacuated tube to reduce the aerodynamic forces. This was an interesting initiative, partly because there had at least been some serious technical studies [29], but also because it was encouraging an open innovation approach for further development of the concept. Such a high speed depends upon the ability to construct and maintain a very accurately aligned track within a low pressure tube over hundreds of kilometres, which is where it becomes really difficult, and very costly. However some of these high-tech propositions make bold claims about cost. In reality transportation providers would be persuaded by the prospect of reducing the system costs by perhaps 30% or 50%, but often the proponents of new concepts suggest much larger savings. As an example the Hyperloop proposal suggests that its costs will be “less than 9% of the cost of the proposed passenger only high speed rail system between Los Angeles and San Francisco”, i.e. more than a 90% reduction in cost compared with a high speed rail system, despite the sophisticated infrastructure that would be required. Unfortunately this takes the ideas from being persuasive to being unbelievable!

Conclusion

Despite the reservations about the long-term future and the “disruptive” prospect of Maglev and other possible technologies that have been proposed, it now seems clear that railways have an important future as the major guided ground transportation system. European railways not only have positive recognition by governments as key elements of national infrastructure, but also have an ambitious vision with well-supported technical strategies. Some of the ideas suggested in this paper will certainly come to fruition whereas others perhaps will not, and it is likely that some as yet unknown technologies will have a major influence on the future.

References

1. Anon, 2011, Realising the Potential of GB Rail, DfT and ORR, ISBN 978 1 84864 124 2
2. Future Railways, Railway Technical Strategy, <http://www.futurerrailway.org/RTS/Pages/Intro.aspx> (accessed 16th December 2013)
3. Shift²Rail Strategic Master Plan, 2014, V1.0, <http://ec.europa.eu/transport/modes/rail/doc/2014-09-24-draft-shift2rail-master-plan.pdf> (accessed 16th Oct 2014)
4. Persson, R., Goodall, R.M. and Sasaki, K., “Carbody Tilting - technologies and benefits” Vehicle System Dynamics, Vol 47 No8, pp 949-981, 2009
5. The IET, “Electric Traction Systems”, 2010, ISBN: 978-1-84919-311-5

6. IEC 61375, "Electronic railway equipment - Train communication network (TCN) - Part 1: General architecture", 2012
7. Anon, "Railway applications. Classification system for railway vehicles. Function groups", EN 15380-4:2013, 2013
8. Hauser, G, West coast main line trains, tilt technology, The Railway Technology Conference (RailTex), Birmingham, November 2002
9. Johnson, J., "Benefits of all-electric braking", RSSB Report T860, Nov 2012.
10. C.P. Ward, T.X. Mei, P. Hubbard and M. Mirzapour, Half cost trains: Design for Control, RRUKA (produced by Loughborough University and University of Salford), 2013
11. C.P. Ward, T.X. Mei, P. Hubbard and M. Mirzapour, Railway Vehicle Optimisation using the Concept of "Design for Control", in J. Pombo, (Editor), "Proceedings of the Second International Conference on Railway Technology: Research, Development and Maintenance", vol. 1(321), doi:10.4203/ccp.104.321, 2014
12. M.B. Tischler, 'Advances in Aircraft Flight Control', Taylor and Francis, London, UK, 1996
13. L. Guzzella and C. Onder, 'Introduction to Modeling and Control of Internal Combustion Engine Systems', Springer-Verlag, New York, USA, 2nd edition, 2009
14. Eurofighter Typhoon, www.eurofighter.com, accessed 30th November 2014
15. S. Iwnicki, Handbook of railway vehicle dynamics, CRC press, Florida, USA, 1st edition, 2006
16. NGT - Next Generation Train, Rail Technology Review: Special, "2011", ISBN 978-3-7771-0435-8
17. T.X. Mei and R.M. Goodall, Practical Strategies for Controlling Railway Wheelsets with Independently Rotating Wheels, ASME Journal of Dynamic Systems, Measurement, and Control, vol. 125(3), pp 354--360, 2003
18. T.X. Mei and R.M. Goodall, LQG and GA Solutions for Active Steering of Railway Vehicles, Control Theory and Applications, IEE Proceedings, vol. 147(1), pp 111--117, 2000
19. T.X. Mei and R.M. Goodall, Robust Control for Independently Rotating Wheelsets on a Railway Vehicle Using Practical Sensors, IEEE Transactions on Control Systems Technology, vol. 9(4), pp 599--607, 2001
20. A. Pacchioni and R.M. Goodall and S. Bruni, Active Suspension for a Two-Axle Railway Vehicle, Vehicle System Dynamics: International Journal of Vehicle Mechanics and Mobility, vol. 48(supplement), pp 105--120, 2010
21. C.P. Ward, P.F. Weston, E.J.C. Stewart, H. Li, R.M. Goodall, C. Roberts, T.X. Mei, G. Charles and R. Dixon, Condition Monitoring Opportunities using Vehicle-Based Sensors, Proceedings of the Institution of Mechanical Engineers, Part F: Journal of Rail and Rapid Transit, vol. 225(2), pp 202--218, 2011
22. R. Goodall and T.X. Mei, Mechatronic Strategies for Controlling Railway Wheelsets with Independently Rotating Wheels, Proceedings of the 2001 IEEE/ASME International Conference on Advanced Intelligent Mechatronics, vol. 1(1), pp 225--230, 2001
23. V.R. Schmitt and J.W. Morris and G.D. Jenney, Fly-by-Wire – A Historical and Design Perspective, SAE publications, PA, USA, 1998
24. Shanghai Maglev Train, http://en.wikipedia.org/wiki/Shanghai_Maglev_Train, accessed 4 Nov 2014
25. China's High-speed Rail Vision, <http://www.scmp.com/infographics/article/1605236/infographic-chinas-high-speed-rail-vision>, accessed 1/11/2014
26. The Chuo Shinkansen, http://en.wikipedia.org/wiki/Ch%C5%AB%C5%8D_Shinkansen
27. R.M. Goodall, "Maglev – an unfulfilled dream?", Proc. Int. Symp. on Speed-up, Safety and Service Technology for Railway and MAGLEV Systems (STECH '12), Seoul, Korea, September 17-19, 2012
28. Hyperloop, <http://en.wikipedia.org/wiki/Hyperloop>
29. Hyperloop Alpha, http://www.spacex.com/sites/spacex/files/hyperloop_alpha-20130812.pdf, accessed Nov 1 2014