

Operational Performance Assessment of Decentralised Energy and District Heating Systems

Oliver Martin-Du Pan

**Buro Happold
17 Newman Street
London
W1T 1PD**

**Centre for Innovative and Collaborative
Construction Engineering
Department of Civil & Building Engineering
Loughborough University
Loughborough
Leicestershire, LE11 3TU**

OPERATIONAL PERFORMANCE ASSESSMENT OF DECENTRALISED ENERGY AND DISTRICT HEATING SYSTEMS

By
Oliver Martin-Du Pan

A dissertation thesis submitted in partial fulfilment of the requirements for the award of the
degree Doctor of Engineering (EngD), Loughborough University

March 2015

© by Oliver Martin-Du Pan 2015

Buro Happold
17 Newman Street
London
W1T 1PD

Centre for Innovative and Collaborative Construction
Engineering
Department of Civil & Building Engineering
Loughborough University
Loughborough
Leicestershire, LE11 3TU

ACKNOWLEDGEMENTS

I would like to express my deepest appreciation to the people, teams and organisations that supported me throughout this doctorate. Firstly, I would like to thank my late academic supervisor, Professor Dino Bouchlaghem for his assistance and coordination in arranging everything for me. Secondly, I would like to thank my principal academic supervisor, Professor Philip Eames for his continuous help, guidance and support; his vast experience provided me with invaluable benefit over the last four years and this thesis would not have been possible without him. Thirdly, I have to thank Dr Gideon Susman who in 2012 became my industrial supervisor. Gideon having just completed a thesis and being a professional industrial expert in energy was definitely the best to influence my daily schedule and for guidance in writing papers and the thesis itself. Fourthly, I need to thank Dr Paul Rowley for his input to also focus my thesis on the end-user side of district heating. Fifthly, I thank Dr Andrew Cripps for introducing me in 2007 to district heating and arranging the beginning of my EngD with Loughborough University.

I also need to thank David Wickersham, Gavin Mackenzie, James Boyd and Chris Richardson from Pimlico District Heating Undertaking for their continuous support of my research allowing me to use their facilities as a case study. Similarly, I thank Greg Watts from Loughborough University and Mike Davison from Strand Palace Hotel for sharing their available raw data.

I thank Benny Boehm for sharing his DHsim code and for putting me in contact with Irena Gabrielaitiene and Helge Larsen that I also thank. Finally, I am grateful to Professor Favrat

from the Ecole polytechnique federal de Lausanne for receiving me and for letting me work and discuss about exergy for a couple of days in their lab.

This research project would not have been possible without funding from the Engineering and Physical Sciences Research Council, Buro Happold and the support of the Centre for Innovative and Collaborative Construction Engineering at Loughborough University.

Although I am half English, I was brought up and educated in the Swiss culture and using the French language so I had my Thesis reviewed by my brother in law Martin Palotai and both colleagues and friends Dr Gideon Susman and Dr Mark Dowson that I thank very much.

This research was encouraged daily by my young son, Arthur who motivated me with his love and his smile; thank you Arthur.

ABSTRACT

District heating systems can contribute to reducing the UK's CO₂ emissions. This thesis investigates the operational performance of current district heating (DH) systems with the existing and a possible future energy sector. The main contributions to knowledge are:

- **Operational, financial and exergy performance assessments of three functioning DH systems and one decentralised energy (DE) technology**
- **A methodology to optimise a DH system in a resource efficient and cost effective way**

The aims of DH systems are to provide heat, reduce CO₂ emissions, ensure energy security by operating in a resource efficient way and to tackle fuel poverty. However, the case studies in this project confirm that DH systems operate poorly in the UK. This is largely because of the heat losses from the DH network to the soil being high and the plant operation being suboptimal.

Four case studies were analysed. The 785 room Strand Palace hotel has two 250 kW_e combined heat and power (CHP) engines set to modulate following the hotel's electricity consumption and providing approximately 90% of this annual demand. It was found that the CHP engines never operate at full load throughout a full day, firstly because the plant cannot export electricity to the grid and secondly the system is not fitted with a thermal store. Financial analysis revealed that the hotel does not reduce its heating cost by operating the CHP engines, but that the energy service company (ESCO) makes £77,000 net operating income per year.

Elmswell in Suffolk (UK) is a low heat density DH system that generates heat with a 2008 biomass boiler and pumps it to 26 terraced and semi-detached dwellings. It was found that 39% of its heat is lost to the soil and that the natural gas boiler generates 45% of the heating load and operates with a seasonal efficiency of 65%. The heat losses to the soil for this system were compared to a DH system of higher heat density, Loughborough University, with a lower heat loss of 22% to the soil.

In August 2011, Loughborough University installed a 1.6 MWe CHP engine to operate with four 3 MWth natural gas boilers to supply heat to its DH network. A study undertaken demonstrated that by adding a 2 MWe CHP engine with a thermal storage instead of a 1.6 MWe CHP engine on its own could further increase the CO₂ emissions savings from 8% to 12.4%.

The energy centre at Pimlico District Heating Undertaking (PDHU) includes a gas fired cogeneration plant that supplies heat to 3 schools, 3,256 dwellings and 55 commercial units. It also benefits from a 2,500 m³ thermal store. Every component of PDHU was investigated in detail and its current operation was optimised and compared to a selection of new operating scenarios. It was found that:

- i) The thermal store operated with 93% thermal efficiency and was not used to reduce the energy consumption or to enable more cogeneration,
- ii) The CHP engines were undersized and generated only 18% of the required heat in 2012,

- iii) The boilers modulate and £ 70,000 could be saved per year by setting them to operate at full load by making use of the thermal store,
- iv) By installing an open-loop heat pump using the river Thames, PDHU could then guarantee to comply with current and likely future policies impacts by setting the energy plant to operate in CHP mode or as an electricity consumer at defined times to benefit from low energy utility costs and to minimise CO₂ emissions.

A comparison of selected performance metrics was then undertaken and it was found that none of the three DH systems operate in a resource efficient way and that the heating cost could be reduced further by optimising the operation of the systems. To do this, a new optimisation methodology is proposed by maximising their exergy efficiency in addition to maximising their overall energy efficiency and CO₂ emissions reduction.

KEY WORDS

District heating, decentralised energy, combined heat and power, heat pump, biomass.

USED ACRONYMS / ABBREVIATIONS

AFC	Alkaline Fuel Cell
AMR	Automatic Meter Reading
CCGT	Combined Cycle Gas Turbine
CHP	Combined Heat and Power
COP	Coefficient of Performance
CO ₂	Carbon Dioxide
DE	Decentralised Energy
DH	District Heating
DHW	Domestic Hot Water
EC	Energy Centre
EngD	Engineering Doctorate
ESCo	Energy Service Company
FiT	Feed in Tariff
HHV	High Heating Value
LHV	Low Heating Value
MCF	Molten Carbonate Fuel Cell
PAFC	Phosphoric Acid Fuel Cell
PEMFC	Proton Exchange Membrane Fuel Cell
PDHU	Pimlico District Heating Undertaking
RE	Renewable Energy
RHI	Renewable Heat Incentive
RO	Renewable Obligation
SH	Space Heating

SOFC Solid Oxide Fuel Cell

NOMENCLATURE

$C_{Additional}$	Annual additional cost for a proposed service
$C_{Agree.contract}$	Agreement contract cost per year (£/yr)
$(C_{Agr.contract})_{ESCo}$	ESCo agreement contract fee (£/yr)
$C_{Baseline}$	Baseline operation cost per year (£/yr)
C_{Maint}	Maintenance cost per year (£/yr)
$(C_{Maint})_{Baseline}$	Baseline maintenance cost per year (£/yr)
$(C_{Maint})_{Scen}$	Scenario maintenance cost per year (£/yr)
$(C_{Maint})_{Technology}$	Technology maintenance cost per year (£/yr)
C_p	Thermal capacity (J/kg·K)
$C_{Repayment}$	Repayment loan per month (£/month)
$C_{Resource}$	Resource energy cost per year (£/yr)
$(C_{Res})_{ESCo_Scen}$	Resource energy cost under the ESCo scenario (£/yr)
$(C_{Resource})_{Scen}$	Scenario resource energy cost per year (£/yr)
C_{Saving}	Operation cost saving per year (£/yr)
C_{Scen}	Scenario operation cost per year (£/yr)
E^+	Electricity consumed (MWh)
E^-	Electricity generated (MWh)
\dot{E}_q^+	Heat exergy consumed (MWh)
\dot{E}_q^-	Heat exergy generated (MWh)
\dot{E}_y^+	Transformation exergy consumed (MWh)
\dot{E}_y^-	Transformation exergy generated (MWh)

E_{Total}^+	Total electricity consumed (MWh)
E_{Sup}^+	Parasitic electricity consumed (MWh)
Q^-	Heat supplied (MWh)
Q^+	Heat consumed (MWh)
Q_{Acc}^+	Heat stored in the thermal storage (MWh)
Q_{Acc}^-	Heat discharged from by the thermal storage (MWh)
Q_{DHN}	Heat supplied to the DH network (MWh)
$Q_{Supply.unit}$	Heat generated by a supply unit (MWh)
\dot{m}	Flow rate (Kg/s)
T_{Sup}	Supplied temperature (°C)
T_{Ret}	Return temperature (°C)
\dot{V}	Volume flow rate (m ³ /s)
W^-	Mechanical work generated (MWh)
W^+	Mechanical work consumed (MWh)
η	Exergy efficiency (%)
$\eta_{Acc.}$	Thermal storage efficiency (%)
η_{pump}	Conversion efficiency for the circulation pump (W)
Ψ	Electricity consumed for pumping (MWhe)

TABLE OF CONTENTS

- Acknowledgements..... i**
- Abstract..... iii**
- Key Words v**
- Used Acronyms / Abbreviations..... vi**
- Nomenclature..... viii**
- Table of Contents x**
- List of Figures xiii**
- List of Tables..... xv**
- List of Publications..... xvi**
- 1 Background to the Research..... 1**
 - 1.1 UK Energy Challenges 2
 - 1.1.1 Climate Change 2
 - 1.1.2 Security of Supply 5
 - 1.1.3 Energy Prices..... 6
 - 1.2 UK Energy Sector 9
 - 1.2.1 Projection of Electricity Demand and Generation 12
 - 1.3 District Heating..... 13
 - 1.3.1 Electrically Powered Supply Unit 15
 - 1.3.2 Primary Fuel Powered Combined Heat and Power Supply Units..... 18
 - 1.3.3 Thermal Storage 23
 - 1.3.4 District Heating Network 23
 - 1.3.5 Substation 25
 - 1.3.6 Consumer 26
 - 1.4 District Heating Performance 26
 - 1.4.1 Load Shifting and Demand Side Management 27
 - 1.4.2 Night Time Set- Back..... 28
 - 1.5 District Heating and the Energy Sector 29
 - 1.5.1 District Heating Integration with Grid Electricity..... 29
 - 1.5.2 Decarbonised Fuel for CHP-DH 31
 - 1.6 DH Implementation 36
 - 1.6.1 The Feed in Tariff (FiT) 37
 - 1.6.2 The Renewable Heat Incentive (RHI) 38
 - 1.7 DH Implementation in Low Heat Density Areas..... 38
 - 1.8 The Industrial Sponsor..... 39
- 2 Overarching Aims and Objectives 41**
 - 2.1 Background to Overarching Aim and Objectives 41
 - 2.2 Overarching Aim 45
 - 2.3 Objectives 46
 - 2.4 Justification of the Objectives..... 47
- 3 Research Methodology 49**
 - 3.1 Introduction..... 49

3.2	Methods Employed	51
3.2.1	Literature Review	52
3.2.2	Case Study and Simulation Approach.....	53
3.2.3	Energy Surveys	56
3.2.4	Operational Management	62
3.2.5	Performance Assessment Metrics	63
4	The Research Undertaken	72
4.1	Elmswell DH.....	74
4.1.1	Development Description.....	74
4.1.2	Description of the District Heating System Operation.....	75
4.1.3	Parasitic and Pumping Electricity Consumption.....	76
4.1.4	DH Network Losses	77
4.2	Loughborough University DH	79
4.2.1	Development Description.....	79
4.2.2	System Operation	80
4.2.3	DH Network Losses	80
4.2.4	Alternative Operation	80
4.3	Strand Palace Hotel.....	82
4.3.1	Building Description	82
4.3.2	Energy Plant Operation	83
4.4	Pimlico District Heating Undertaking	85
4.4.1	Development Description.....	85
4.4.2	System Operation	87
4.4.3	Thermal Storage Operation	89
4.4.4	Supply Unit Performance	90
4.4.5	Parasitic Electricity Consumption.....	93
4.4.6	Electricity Required for Pumping the DH Flow.....	94
4.4.7	DH Network Losses	95
4.4.8	Substation and Consumers	97
4.4.9	Alternative Operation	98
4.5	Results Comparison	104
4.5.1	Resource Use and Energy Production	104
4.5.2	DH Network Losses	106
4.5.3	Electricity Consumption for Pumping the DH Flow.....	107
4.6	Performance Metrics Comparison	112
4.6.1	Financial Analysis	112
4.6.2	CO ₂ Emission Comparison.....	115
4.7	Grid Decarbonisation	118
4.7.1	Grid Decarbonisation Applied to PDHU	119
4.8	Optimisation and Exergy Analysis	121
5	Findings and Implications	123
5.1	Key Findings of the Research.....	123
5.1.1	The Operational Performance of Each Component of a DH System Were Assessed.....	123
5.1.2	Opportunities to Reduce Losses in Each Operating Components of a DH System	126
5.1.3	Minimising the Overall Losses of a DH System.....	127
5.1.4	A DH System Optimisation Methodology was Developed	127

- 5.2 Contribution to Existing Theory and Practice 129
 - 5.2.1 Contribution 1 129
 - 5.2.2 Contribution 2 130
- 5.3 Implications/Impact on the Sponsor 131
- 5.4 Implications/Impact on Wider Industry 132
- 5.5 Recommendations for Industry/Further Research 132
- 5.6 Critical Evaluation of the Research 133
- 6 References..... 135**
- Appendix A Post Occupancy Evaluation and Heat Meters..... 143**
 - Appendix A1 Post Occupancy Evaluation of Decentralised Energy Systems (Paper 1)..... 143
 - Appendix A2 Heat Losses in District Heating Systems and Heat Meters (Abstract - Submitted) 154
- Appendix B A Decentralised Energy System Contribution Towards a Low Carbon Economy - UK (Paper 2)..... 156**
- Appendix C Current and Future Operation Scenarios for a 50,000 MWh District Heating System (Paper 3) 169**
- Appendix D Comparison and Exergy Analysis of Heat Supply Scenario for a 50,000 MWh District Heating System (Paper 4) 200**
- Appendix E District Heating Optimisation (Paper 5)..... 213**

LIST OF FIGURES

Figure 1- 1	The energy challenges (CIBSE, 2013)	2
Figure 1- 2	UK greenhouse gas emissions: Progress towards targets (DECC, 2013b)	4
Figure 1- 3	UK's net percentage of energy import or export (DECC, 2013a)	6
Figure 1- 4	Fuel price indices for the industrial sector relative to 2005, 1980 to 2011 (DECC, 2013a)	7
Figure 1- 5	Number of UK fuel poor homes (DECCa, 2013).....	8
Figure 1- 6	UK electricity generation from renewables (DECC, 2013a).....	10
Figure 1- 7	Growth in total UK electricity generation from Renewables since 2000 (DECC, 2013a)	11
Figure 1- 8	Oil equivalent energy use by sector (DECCb, 2013)	12
Figure 1- 9	Total end-user electricity demand (National grid, 2012)	13
Figure 1- 10	A schematic diagram of a DH system	14
Figure 1- 11	A 10 to 15 MW capacity water to water heat pump (UNITOP 50FY)	17
Figure 1- 12	A flow diagram of a two-stage compression heat pump and a T-S diagram with ammonia working fluid for its thermodynamic cycle (Borel and Favrat, 2010).....	17
Figure 1- 13	Innovative hybrid cycle flow-chart (Facchinetti et al., 2011)	22
Figure 1- 14	Comparison of the traditional set point supply temperature with a variable supply temperature and flow rate based on predicted demands (Schneider-electric, 2014)	25
Figure 1- 15	Integration of centralised and decentralised energy generation (CleanTechnica, 2014).....	29
Figure 1- 16	Integration of the renewable electricity generation with storage	30
Figure 1- 17	District heating compared to individual oil boilers (International Energy Agency 2008).....	39
Figure 3- 1	A flow diagram of the adopted methodology.....	50
Figure 3- 2	DH system CO ₂ emission compared to the UK baseline	64
Figure 3- 3	DH system boundaries at T _{ref} and P _{ref} (Favrat et al., 2008).....	70
Figure 4- 1	Elmswell - Energy efficient residential development (Buro Happold, 2009)	75
Figure 4- 2	Elmswell's dwelling types and grouping (Buro Happold, 2009).....	76
Figure 4- 3	The site's seasonal DHW + SH consumption, from 1-4-2009 to 9-4-2010 (30-10- 2009 half way through and switching from summer to winter heating load).....	78
Figure 4- 4	Loughborough University campus (Lboro, 2013).....	79
Figure 4- 5	Strand Palace hotel in central London.....	83
Figure 4- 6	Strand Palace Hotel monthly heat production and consumption.....	84
Figure 4- 7	Pimlico District Heating Undertaking	86
Figure 4- 8	Pimlico district heating network.....	86
Figure 4- 9	Schematic of PDHU district heating system and its nine legs	87
Figure 4- 10	Annual daily heat generation by supply unit.....	88
Figure 4- 11	Natural gas consumption duration curve for each supply unit	89
Figure 4- 12	Thermal store dynamic heat level for a typical winter and summer week	90
Figure 4- 13	Efficiency of boilers over their modulation range.....	91

Figure 4- 14 Efficiency of CHP engines over their modulation range at PDHU (on the left) and from Ener-G technical datasheet of the E230 (on the right)..... 92

Figure 4- 15 Boilers (left chart) and CHP engines (right chart) parasitic electricity consumption for the combustion process and pumping the cooling flow. 94

Figure 4- 16 Electrical power to pump a known amount of heat at PDHU 95

Figure 4- 17 Zone 1 measured supply and return temperature and volumetric flow rate (29-11-2012)..... 96

Figure 4- 18 Cross flow heat exchanger for $m1 = m2$ and with inlet temperatures of 65°C and 15 °C..... 97

Figure 4- 19 Similar daily heating load with and without 2 hour load shifting 103

Figure 4- 20 Percentage of heat generated by each conversion system 105

Figure 4- 21 DH network pumping electricity at Elmswell and PDHU 108

Figure 4- 22 DH network progressing pressure 111

Figure 4- 23 Financial performance of the Strand Palace hotel's energy plant compared to the baseline 113

LIST OF TABLES

Table 1- 1 Fuel cell types	21
Table 3- 1 Summary of the methods/tools used in each case study	52
Table 4- 1 Research undertaken	73
Table 4- 2 Scenario comparison for Loughborough University DH system.....	81
Table 4- 3 Heat pump operation simulation using the current and a 2 hour load shifting profile	102
Table 4- 4 Primary energy analysis	104
Table 4- 5 Exergy efficiency of each plant's operation.....	106
Table 4- 6 DH network efficiencies and heat losses	106
Table 4- 7 DH network electricity consumptions for pumping	109
Table 4- 8 Current CO ₂ emissions compared to the baseline scenario	116
Table 4- 9 Energy consumed from the EC and provided to the end-user	120
Table 4- 10 Current and near future CO ₂ emissions	121

LIST OF PUBLICATIONS

The following publications, included in the appendices, have been produced in partial fulfilment of the award requirements of the Engineering Doctorate during the course of the research.

PUBLICATION 1 – CONFERENCE PAPER (APPENDIX A)

Martin-Du Pan, O., Bouchlagem, D., Eames, P., Young, A., Gill, Z., 2011.

Post occupancy evaluation of decentralised energy systems. Sustainability in energy and buildings, SEB'11 – 20011, Marseille, France.

PUBLICATION 2 – CONFERENCE PAPER (APPENDIX B)

Martin-Du Pan, O., Eames, P., Bouchlagem, D., Cooke, H., Young, A., 2012.

A decentralised energy system contribution towards a low carbon economy – UK. 7th International conference on innovation in architecture, engineering & construction: 15-17 August, The Brazilian British Centre, São Paulo, Brazil.

PUBLICATION 3 – JOURNAL PAPER (APPENDIX C)

Martin-Du Pan, O., Eames, P., Bouchlagem, D., Rowley, P., Susman, G., 2014.

Current and future operation scenarios for a 50,000 MWh district heating system. Architectural engineering and design management,
<http://dx.doi.org/10.1080/17452007.2014.899889>.

PUBLICATION 4 – CONFERENCE PAPER (APPENDIX D)

Martin-Du Pan, O., Eames, P., Rowley, P., Bouchlagem, D., Susman, G., 2014.

Comparison and exergy analysis of heat supply scenarios for a 50,000 MWh district heating system, Eurosolar, the 8th international renewable energy storage conference. 7-8 November Berlin.

PUBLICATION 5 – INDUSTRIAL GUIDANCE (APPENDIX E)

Martin-Du Pan, O., Eames, P., Rowley, P., Bouchlagem, D., Susman, G., 2014.

District heating optimisation. The 14th international symposium on district heating and cooling. DHC+ technology platform. 7-9 September 2014: Stockholm.

1 BACKGROUND TO THE RESEARCH

As stated by the first law of thermodynamic, changes in total energy of systems can only be accomplished by adding or removing energy from them. When heat is generated, the heat is often seen as waste, but there is the possibility to capture it and use it to meet heat demands through district heating (DH). This captured heat could be used in a variety of ways such as to supply heat to the industrial, residential, service, and agricultural sectors. In manufacturing industries, processes require high temperature heat as well as lower temperature heat for drying products and supplying their premises with comfortable indoor temperatures. In the residential and service sector, heat is used for space heating (SH) and for domestic hot water (DHW). In the agricultural sector, heat is required for drying crops and to heat animal shelters.

DH is an energy service that supplies heat to consumers. A DH system is composed of an energy centre (EC), a DH network, a substation and consumers' heating systems. Distributing heat efficiently in urban areas is the main goal of DH and a DH system can operate in a cost effective and resource efficient way.

This thesis aims to investigate the operating efficiencies of three existing DH systems and one building CHP system and to identify key requirements to operate them in an efficient way. Finally, this thesis also investigates the integration of DH system in the current and possible future energy supply sector.

1.1 UK ENERGY CHALLENGES

Today, the UK faces three major energy challenges in the supply and use of energy, as shown in Figure 1- 1. These challenges are: Carbon dioxide (CO₂) reduction, security of supply and the cost of energy (CIBSE, 2013).

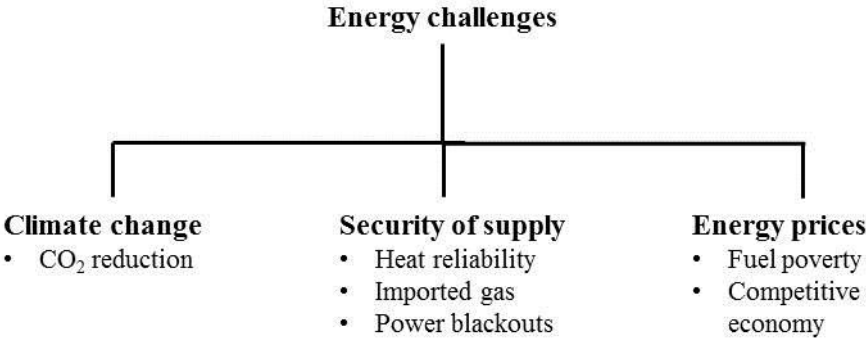

Figure 1- 1 The energy challenges (CIBSE, 2013)

1.1.1 CLIMATE CHANGE

Carbon dioxide (CO₂) is a naturally occurring chemical compound which exists as a gas, at a concentration of approximately 0.04 per cent by volume in the Earth’s atmosphere. It is also man-made and produced by combustion of coal or hydrocarbons and is an important greenhouse gas absorbing long wave radiation from the Earth’s surface which otherwise would leave the atmosphere (Yamin, 2005). Combustion of carbon-based fuels since the industrial revolution has rapidly increased the concentration of atmospheric carbon dioxide and its increasing concentration is believed by many to be the main cause of the increasing rate of global warming and climate change.

Risks from climate change are now broadly accepted and the need to reduce cumulative CO₂ emissions has become a fundamental part of the energy policies of mostly all countries with the Copenhagen Accord committing nations to joint action (UNFCCC, 2009). In the UK the Climate Change Act 2008 has set a legally binding requirement for an 80% reduction in CO₂ emissions from 1990 levels by 2050 (Climate Change Act, 2008). The Act aims to enable the United Kingdom to become a low-carbon economy and gives ministers powers to introduce the necessary measures to achieve a range of greenhouse gas reduction targets. An independent “Committee on Climate Change” has been created under the Act to provide advice to the Government on these targets and related policies. On 1st December 2008 the committee published its first major report entitled “Building a low-carbon economy – the UK’s contribution to tackling climate change” (CCC, 2008). In line with this report, the Government set an additional target to cut its carbon emission by 33% by 2020 (Climate Change Act, 2008). The UK was the first country to set such a stringent target and was followed by other countries choosing different ways to achieve similar outcomes. For example, after the nuclear disaster on the 11th of March 2011 in Fukushima Daiichi, Japan, Germany committed to generating 60% of its total energy demand from renewable resources with 80% of its electricity from renewables while reducing its nuclear energy supply to zero (AGEEstat, 2012).

As shown in Figure 1- 2, the UK has already started the journey to reduce its CO₂ emissions compared to the 1990 baseline and has already achieved the Kyoto Protocol requirement of reducing its CO₂ emissions by 12.5% by 2012. Although the 2020 target seems achievable, the 80% reduction in CO₂ by 2050 is very challenging (DECC, 2009). This will involve the use of renewable technologies with energy storage facilities and/or an increased use of nuclear energy.

Additional policies for emissions reductions are the EU Emissions Trading System (EU ETS), energy efficiency policies, and increased use of renewable energy (RE) for heat and transport (European commission, 2008). The EU ETS is the first multilateral carbon trading system of its scale and is expected to account for over 65% of the emissions savings in Europe by 2020. It is expected to reduce Europe’s emissions by around 500 million tonnes by 2020, which is close to the UK’s total carbon dioxide emissions. Furthermore, about half of the UK’s carbon dioxide emissions are in scope of the EU ETS, so the aim is to reduce the emissions of the UK power sector and heavy industries by 22% from 2008 levels by 2020 (HM Government, 2009).

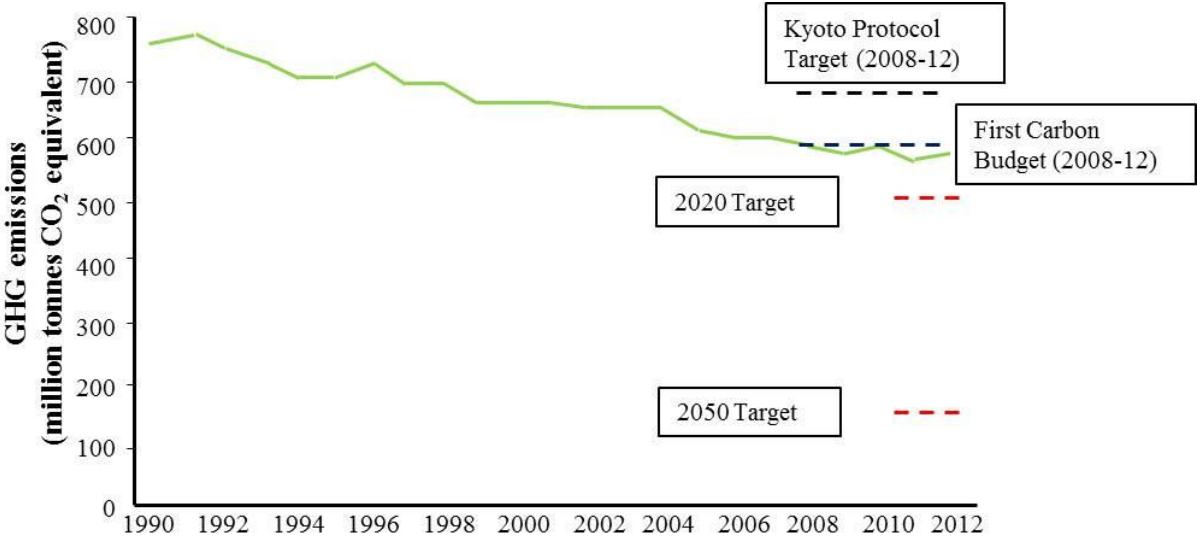

Figure 1- 2 UK greenhouse gas emissions: Progress towards targets (DECC, 2013b)

1.1.2 SECURITY OF SUPPLY

Although UK gas supplies are declining, natural gas will continue to be a significant source of energy for heating during the transition to a low carbon economy. Thus, the UK is required to make better use of it, such as by combusting it in cogeneration plants. During this transition period, renewable technologies will be developed further and decentralised energy (DE) is hoped to be a major contributor to supplying the nation with low carbon energy at an affordable cost. Leading the way, London aims to generate 25% of its energy use from DE by 2025 (GLA, 2010).

As shown in Figure 1- 3, oil production in the UK started from 1975. Thus, the UK benefitted from its indigenous energy resources of coal, oil and natural gas for many years. As shown in Figure 1- 3, the UK became a net importer of energy in the late 1980s and early 1990s and this was due to the production of oil that dipped at that time following the Piper Alpha incident in 1988 (Bolton, 2013). Since 2003, the UK is a net importer of energy and is increasingly dependent on an indigenous declining fossil fuel resource set against a background of rising energy demand. Thus, energy security and increasing market prices are becoming concerns. As shown in Figure 1- 3, 36% of energy used in the UK was imported in 2011. However, Geologists estimate there could be as much as 1,300 tn cubic feet of shale gas lying under parts of the UK in the North and Midlands; one tenth of that would equal around 51 years' gas supply for the UK (The Guardian, 2014) and other reports indicate that shale gas production in Britain could begin within four years (Reuters, 2014).

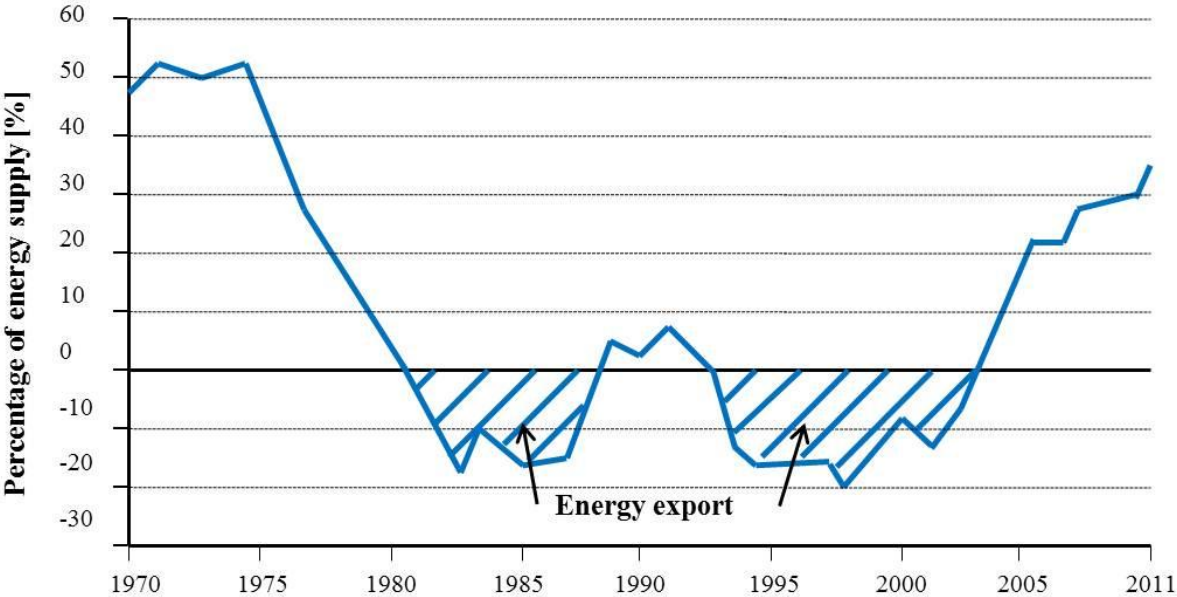

Figure 1- 3 UK's net percentage of energy import or export (DECC, 2013a)

1.1.3 ENERGY PRICES

As the UK benefited from its indigenous energy resources until 2004, the energy price remained generally low and stable from the late 1980's to 2005. Figure 1- 4 shows energy prices relative to the price in 2005. The UK is now in a situation where it is becoming increasingly dependent on imported fossil fuel against a background of rising worldwide energy demand and prices. In addition to this, the UK also needs to replace existing coal and nuclear power stations capacity with the likely consequence of further increases in energy prices and fuel poverty.

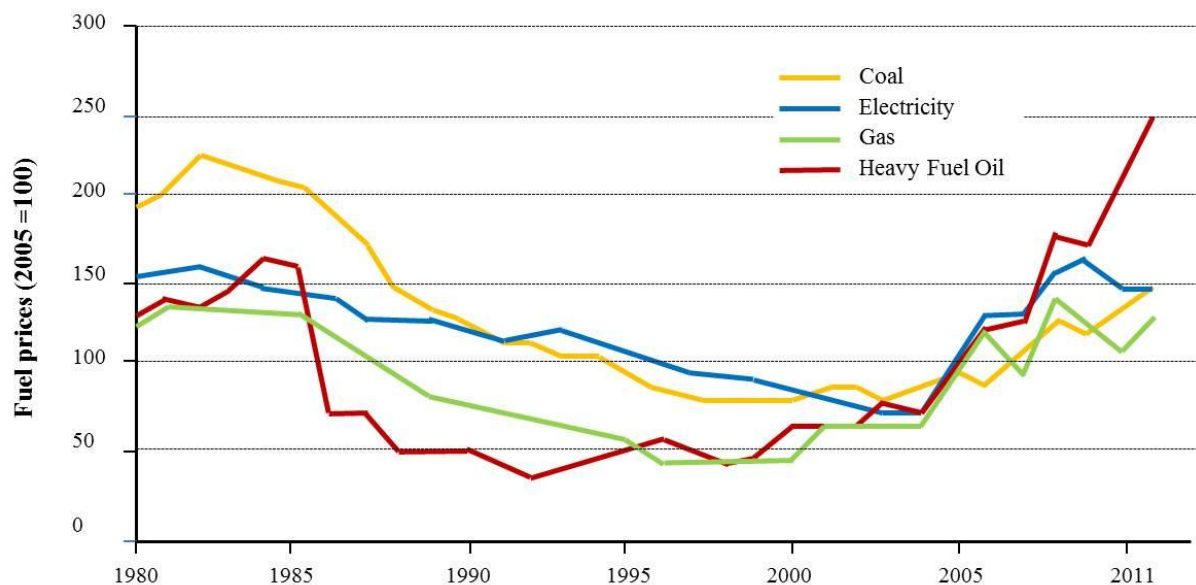

Figure 1- 4 Fuel price indices for the industrial sector relative to 2005, 1980 to 2011 (DECC, 2013a)

Fuel poverty

According to Boardman (2010) households were considered fuel poor if, in order to maintain a satisfactory heating regime, they needed to spend more than 10% of their income on all household energy use. However, in 2013 this definition was updated (DECCc, 2013). The new definition of fuel poverty is now based on the Low Income High Costs framework that was recommended by Professor Hills in his independent review (Hills, 2012). The main difference between Professor Hills' and the former definition is the way in which fuel costs have been identified.

Figure 1- 5 shows that in 1996 approximately 6.5 million households were in fuel poverty, this number decreased to 2 million by 2003, but returned to 5.5 million in 2009 due to higher

energy prices. As fuel poverty is very dependent on prevailing fuel prices, the number of fuel poor homes throughout the years presented in Figure 1- 5 is strongly correlated with the fuel price costs given in Figure 1- 4.

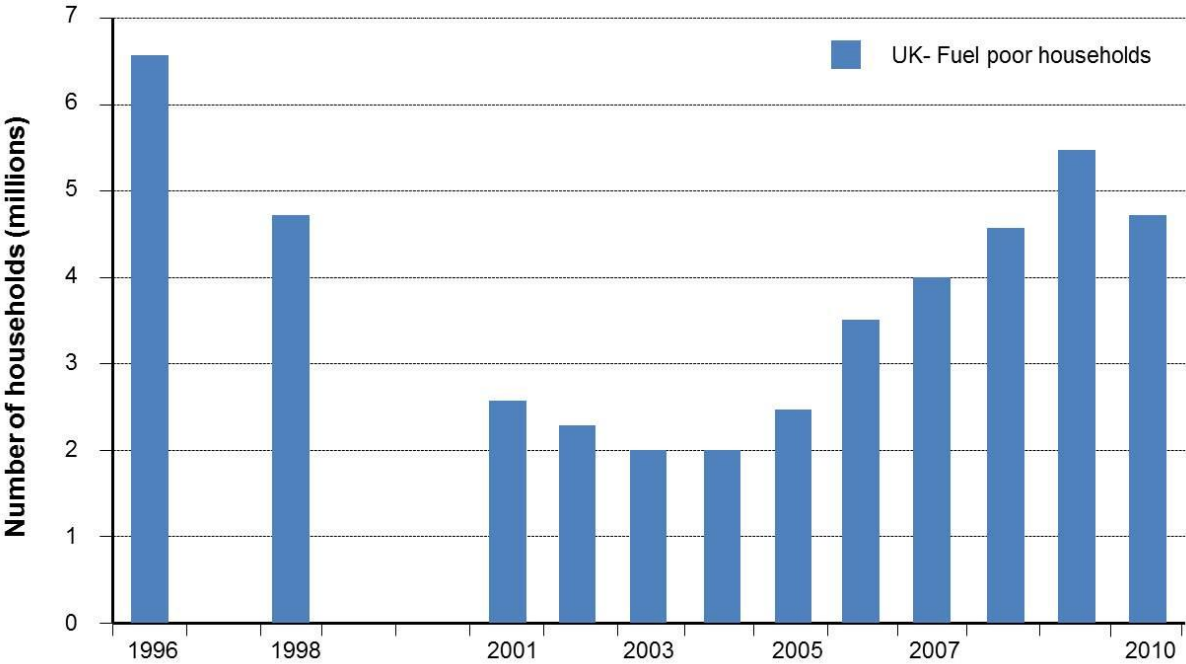

Figure 1- 5 Number of UK fuel poor homes (DECCa, 2013)

As energy prices are currently increasing, measures are required if the Government is to meet the legally binding target to eradicate fuel poverty by 2016 (FPAG, 2012). As discussed in the Energy Bill Revolution campaign report (Camco, 2012), to eradicate fuel poverty and to deliver against the CO₂ reduction targets, the energy performance of the UK’s existing housing stock needs to be improved radically. Their research focus was to assess the environmental, social and economic benefits of using carbon taxes to make existing fuel poor homes more efficient and their key finding was that if carbon tax revenues were allocated to tackle fuel poverty, the current 9.1m fuel-poor homes could be eradicated by 2027.

1.2 UK ENERGY SECTOR

The energy sector is changing: On Sunday 30th March at 15:17, electricity generation on the UK national grid was 29.4 GW, with 48.5% of this electricity generated from coal, 12.9% from combined cycle gas turbine (CCGT), 23.7% from nuclear, 4.5% from wind and 10.4% from other sources such as biomass or hydro (U.K. National Grid Status, 2014). However, at other times such as on Tuesday 18th March 2014 at 19:20, there was 45 GW of demand from the National Grid electricity with 14.5% provided by wind power. By comparing both given times of national electricity generation, it can be noticed that the variability of wind leads to very high fluctuations in renewable electricity output. Furthermore, the UK is guided by the Renewable Obligation (RO) to generate 30-35% of renewable electricity by 2020 (Ofgem, 2010) and the variability of renewable electricity generation and energy demand will require an energy storage infrastructure; Section 1.5 discusses this in more details.

As RE technologies are entering the energy sector with a power generation capacity dependent on variable weather conditions, an energy storage infrastructure is becoming essential. This would enable storing power for later use when the output from RE generation falls due to a period of low wind on an overcast day. As nuclear power stations cannot adapt and modulate as rapidly as the variable demands and generation from the renewable technologies, nuclear power station generating a base electricity load could become redundant if large scale storage is used. However, as the UK total power load is predicted to continue to increase with increasing population and energy storage is limited, the base electricity generation is currently set to remain in use for the foreseeable future (National grid, 2012). Hence, the Government published in March 2006 an Energy Review in which it proposed to allow nuclear power back into the energy debate after it had been side-lined in the 2003 White

Paper (HM Government, 2006). At present, the UK Government believes that nuclear power stations are a key component in tackling climate change and plans have been set to deliver around 16.5 GWe of new nuclear generation capacity by 2030; this would require at least five new nuclear power plants with a total of at least 12 new nuclear reactors (HM Government, 2013). However, in the longer term, RE technologies will continue to emerge and may potentially generate 100% of the future energy consumed in the UK; this goal would also contribute to tackle the energy security of supply as discussed in Section 1.1.2. As can be seen in Figure 1- 6 and Figure 1- 7, approximately 45 TWh or 11% of electricity demand was generated from renewable sources in 2012.

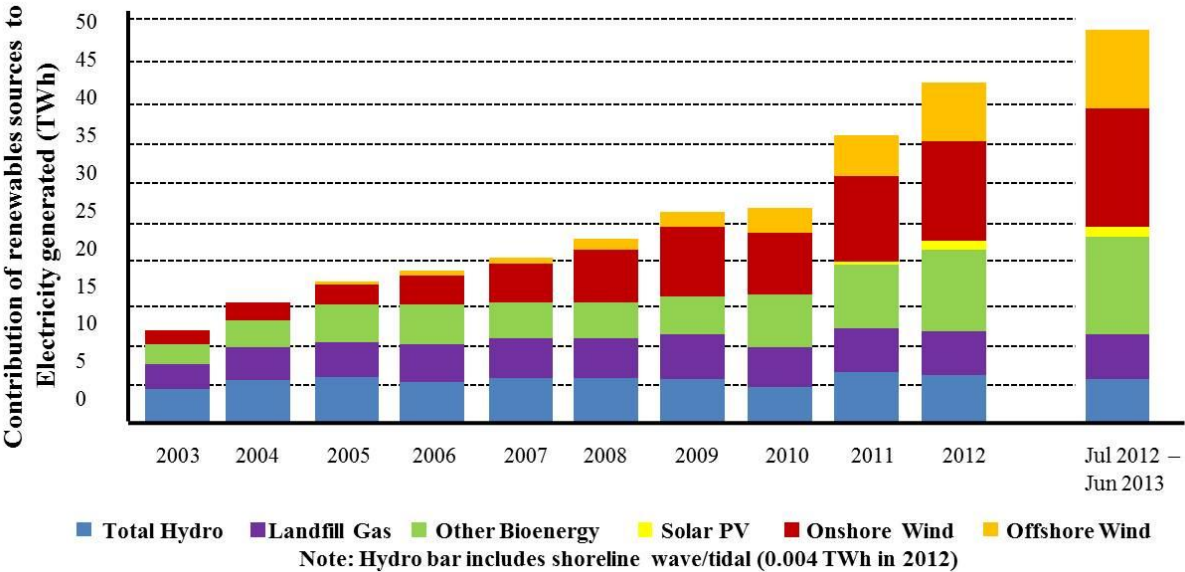

Figure 1- 6 UK electricity generation from renewables (DECC, 2013a)

The UK has had two main legal instruments for the generation of electricity from renewable resources:

- The Non Fossil Fuel Order from 1990 to 1998; and
- The Renewable Obligation (RO) from April 2002 to today (Ofgem, 2011).

The RO obliges electricity supply companies to generate an increasing proportion of their electricity from RE sources. As shown in Figure 1- 7, renewable electricity generation was 4.9% in 2004/5 and is planned to rise to 15% by 2015 and to 30-35% by 2020.

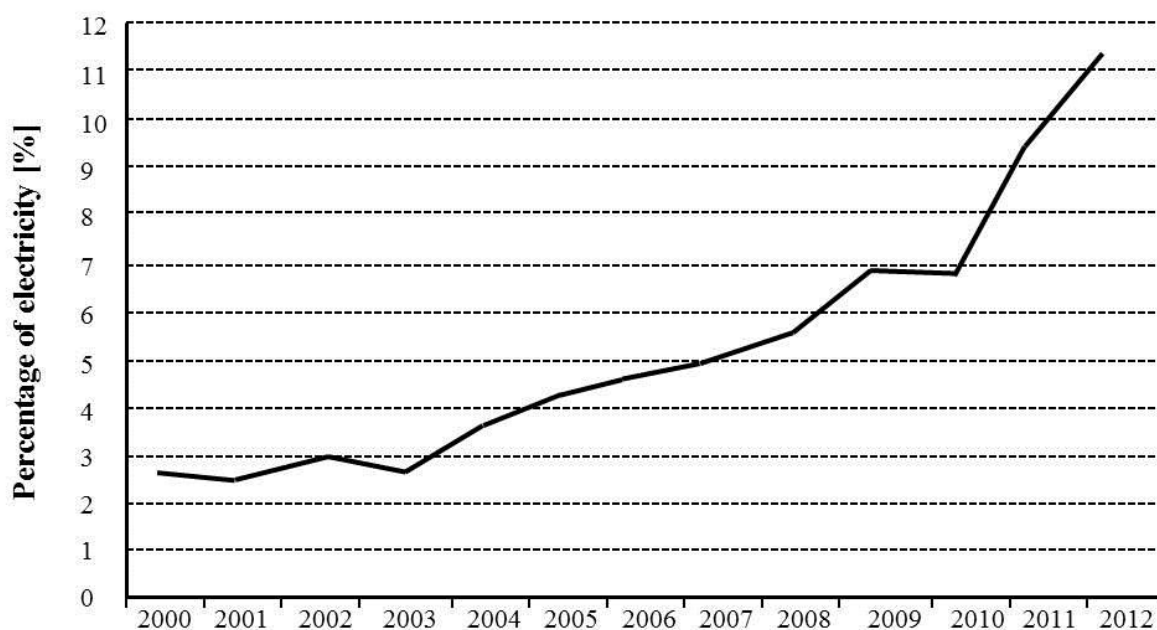

Figure 1- 7 Growth in total UK electricity generation from Renewables since 2000 (DECC, 2013a)

Energy consumption by sector

Figure 1- 8 shows the distribution of mainland energy consumption throughout all sectors. It is quantified on the scale of “Million tonnes of oil equivalent”; a million tonnes of oil equivalent is equal to approximately 42 GJ (Bioenergy conversion factors, 2014). Figure 1- 8 also shows that the final total energy consumption was 138.3 million tonnes of oil equivalent in 2011 which was 8% lower than in 2010. This consumption fell by 20% in the domestic sector but remained broadly unchanged in the transport sector. 82% of the total energy used in

the domestic sector is for space heating (SH) and DHW which accounts for 13% of the UK’s greenhouse gas emission (DECCb, 2013).

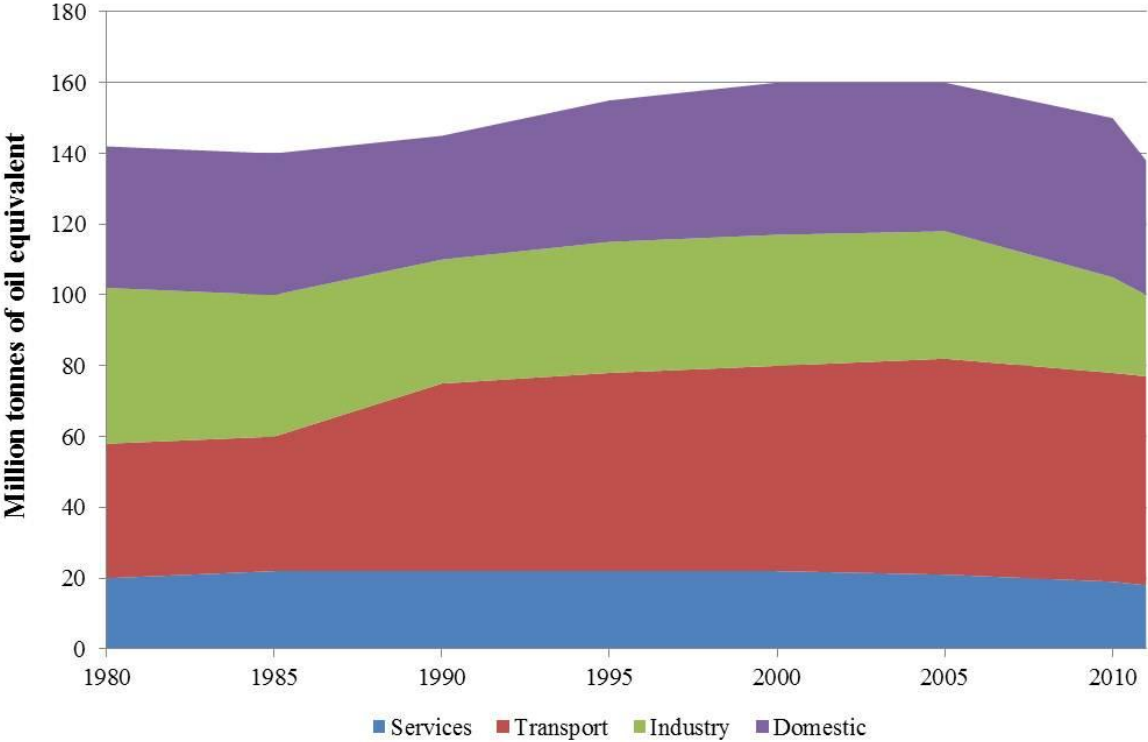

Figure 1- 8 Oil equivalent energy use by sector (DECCb, 2013)

1.2.1 PROJECTION OF ELECTRICITY DEMAND AND GENERATION

Figure 1- 9 shows that the current end-use electricity demand in the UK is of less than 320 TWhe per year and how it is expected to increase for different scenarios to 2030 (National grid, 2012). From 6 May 2013 – 5 May 2014, the total electricity generated was of 307 TWhe (U.K. National Grid Status, 2014). Electricity generation in the UK does not meet consumption because the UK grid is connected by submarine power cables to the Irish and European grid and can export and import electricity (ICPC, 2009) and transmission and

distribution losses occur between the power plant and the customers' electricity meters. The two main imports of electricity were from France and Netherlands and were during the time period 13 TWh and 7 TWh respectively and the losses were in 2012 of 6.8 TWh from the transmission and 21.1 TWh from the distribution (National Statistics, 2013).

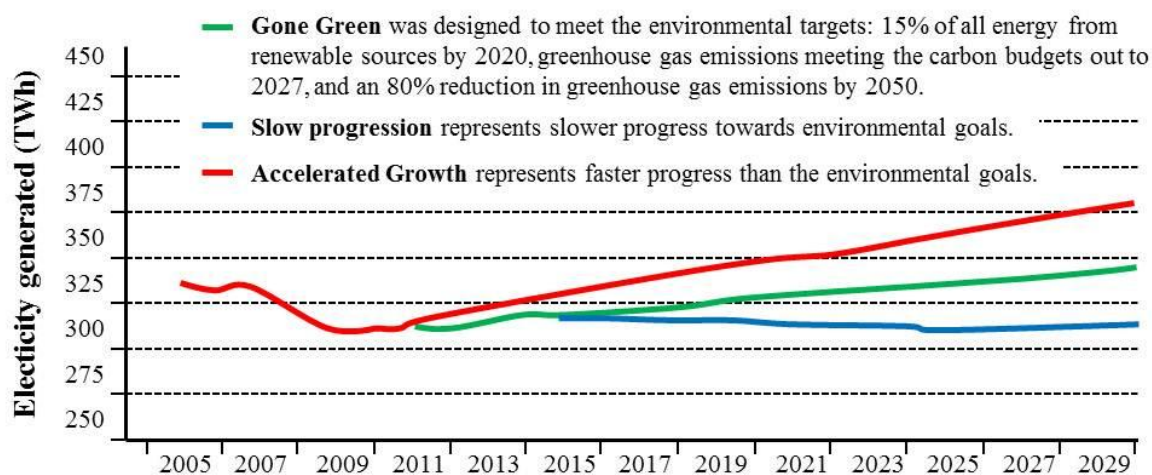

Figure 1- 9 Total end-user electricity demand (National grid, 2012)

1.3 DISTRICT HEATING

DH is an energy service based on moving heat from available heat sources to consumers (Werner, 2013). Advantages of DH systems are that they can i) use waste heat, ii) facilitate the use of RE sources such as biomass by centralising the heat generation and iii) generate heat from renewable electricity helping to mitigate the anticipated needed storage infrastructure.

As illustrated in Figure 1- 10, a pressurised flow, usually hot water, is pumped from an EC to consumers through a DH network. DH networks are well insulated and usually buried pipes which form a heating grid to enable connection to consumers. These consumers are directly or indirectly connected to the DH network by the use of a substation to exchange heat or divert the DH flow to the load.

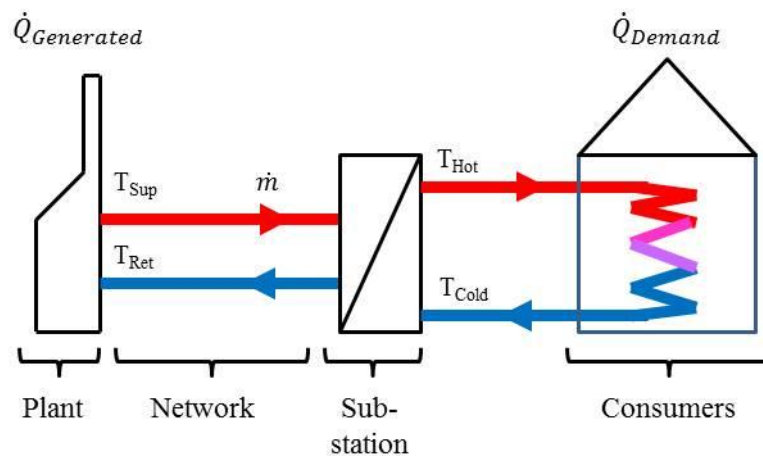

Figure 1- 10 A schematic diagram of a DH system

The EC of a DH system houses the heat source and the pumps which pump the generated or captured heat to consumers. Heat generation or recovered may be non-synchronous with heat demand if thermal energy storage is included in the DH system. However, heat generating technologies, also termed supply units, may generate heat by using electricity or by transforming a primary fuel. Hence, an EC may have one or more of the three following main elements:

- Electrically powered supply unit
- Primary fuel powered supply unit
- Thermal storage

1.3.1 ELECTRICALLY POWERED SUPPLY UNIT

Electrical boilers and heat pumps are the two technologies enabling power to heat conversion. An electrical boiler heats the DH flow with an immersion heater; a heat pump increases the DH flow return temperature by mechanically compressing a refrigerant that was previously evaporated by a heat source. This heat source may either be recovered low temperature waste heat from an industry, sewage water or ambient energy such as heat from the ground, a water flow or the ambient air.

A heat pump provides thermal energy from a heat source such as the atmosphere or a river to a heat sink such as a building. It moves thermal energy opposite to the law zero of thermodynamics, which states that two systems in contact and in equilibrium have a common quantity called “*temperature*”. Thus, it is then possible to say that both systems in thermal equilibrium are at the same temperature (Borel and Favrat, 2010). A heat pump cools the colder heat source and heats the warmer cold sink. To do so it requires energy input that can be mechanical, thermal or magnetic. However, the most widely used type of cycle uses mechanical compression driven by an electrical compressor. The characterisation of a heat pump is given by the heat rate and by the temperature level of the cold and the hot source. As the remaining energy in the balance is delivered by the environment - the colder source, the coefficient of performance (COP) of a heat pump is usually higher than one (Borel and Favrat, 2010).

One of the key issues with decreasing the losses in a heat pump cycle is to reduce the exhaust temperature of the compressor, i.e. by increasing the compressor efficiency and selecting the right refrigerant. Another way is to split the compression process into two or more stages to

reduce the expansion losses of the compression (Schiffmann, 2008). For illustration, Figure 1-11 is a 2-stage water to water heat pump with a capacity ranging from approximately 10 to 15 MW.

A two stage compression heat pump is explained with both a flow sheet and an entropy – temperature thermodynamic cycle given in Figure 1- 12 (Borel and Favrat, 2010). However, although the used refrigerant in this heat pump is the R-1234, the given thermodynamic cycle assumes a similar heat pump cycle but uses ammonia for reference. A two stage-heat pump operates with two individual circuits to increase the pressure and the temperature further, the refrigerant circulates through two turbo-compressors: A low-pressure and a high pressure turbo-compressor. The intermediate vessel, also called the economiser or the internal heat exchanger simultaneously condenses the mixture coming from the high pressure expansion valve and cools at constant pressure the vapour discharged from the low-pressure turbo-compressor. This enables the heat pump to compress the refrigerant further and closer to the saturation curve and the latent heat.

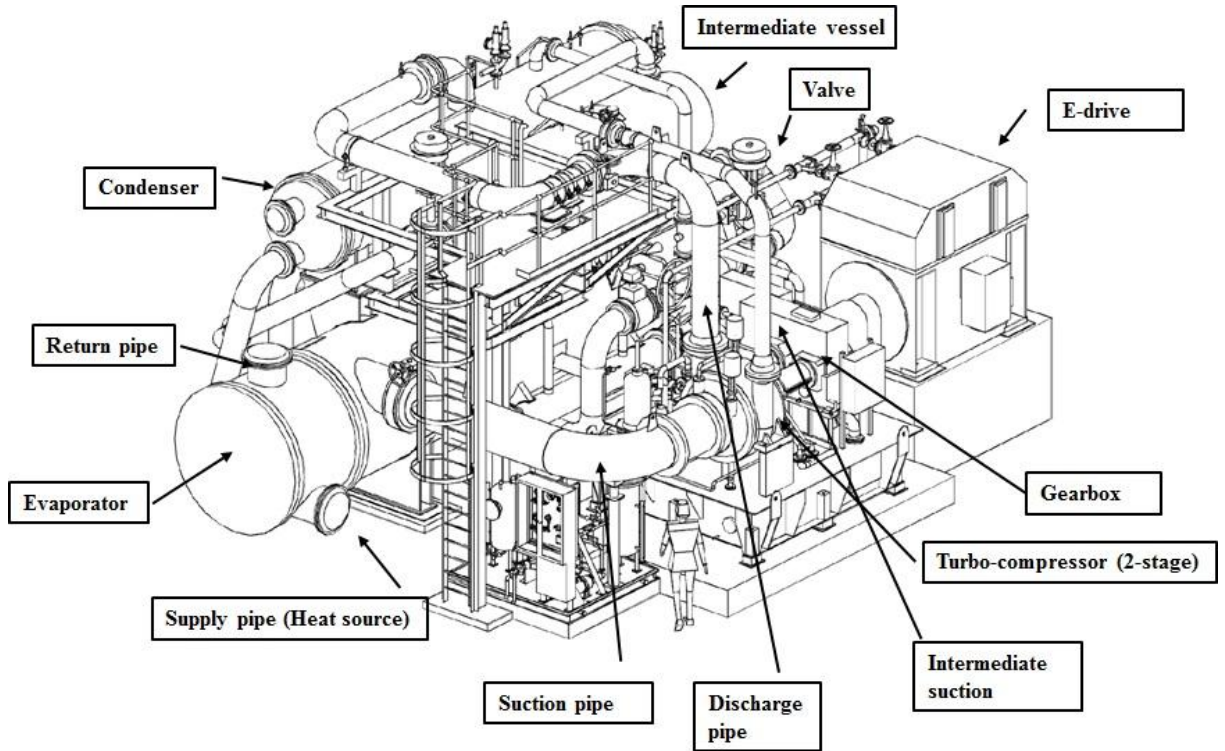

Figure 1- 11 A 10 to 15 MW capacity water to water heat pump (UNITOP 50FY)

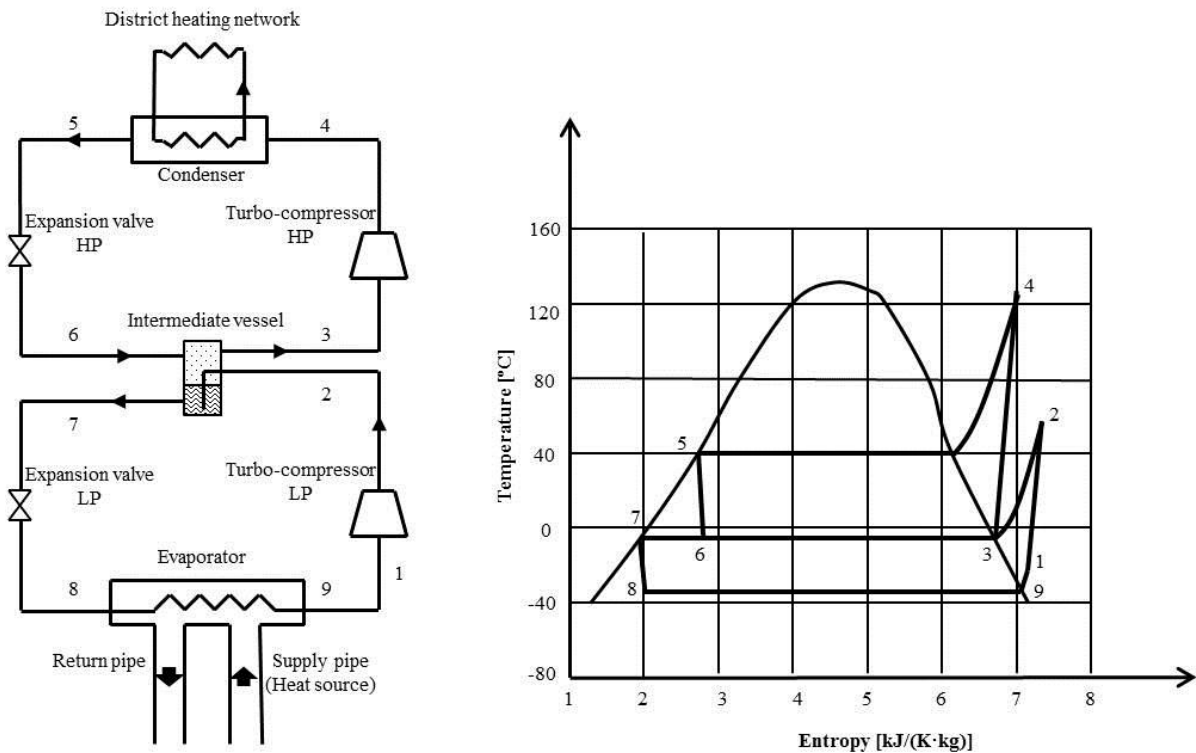

Figure 1- 12 A flow diagram of a two-stage compression heat pump and a T-S diagram with ammonia working fluid for its thermodynamic cycle (Borel and Favrat, 2010)

1.3.2 PRIMARY FUEL POWERED COMBINED HEAT AND POWER SUPPLY

UNITS

As well as the advantages discussed in Section 1.3, another benefit of a DH system is to supply heat in a cost effective and resource efficient way by generating electricity that can also be consumed locally. As electricity is a more valuable energy than heat, the efficient use of resources can be obtained from operating a plant for cogeneration with the use of the following supply units:

- Reciprocating engines known as combined heat and power (CHP) engines
- Gas turbines
- Steam turbines
- Fuel Cells

These cogeneration technologies generate heat and electricity by using one of the three following physical reactions:

- **Combustion:** This applies to fossil fuels or renewable fuels such as biomass. Combustion is the sequence of exothermic chemical reactions between fuel and an oxidant. CO₂ and water vapour are both chemical species resulting from a combustion reaction (Heywood, 1988).
- **Electrochemical reaction:** This reaction involves electron transfer between the electrode and the electrolyte in a solution. It deals with interactions between electrical energy and chemical change. These reactions are exothermic (EG&G Technical Services, 2002).

- Nuclear fission: It is a process in which the nucleus of a particle splits into smaller parts. A neutron is absorbed by a uranium-235 nucleus, turning it into a uranium-236 nucleus. This nucleus then splits into fast-moving lighter elements and releases three free neutrons. This is an exothermic reaction (Wagemans, 1991).

1.3.2.1 CHP Engines

Derived from engines used in vehicles, gas fired CHP engines are the most common type of CHP system. These gas engines are based on spark-ignition and operate with an electrical efficiency ranging from 30 - 40%. Their sizes range from 50 kWe to around 10 MWe with a typical lifespan of 15 years (Heywood, 1988).

1.3.2.2 Gas Turbines

Gas turbines are also used in power stations and the aviation sector. Gas turbines are available in a range from 500 kWe to over 200 MWe (Wartsila, 2014). This type of system is particularly well adapted for the aviation sector. However, gas turbines can also be used in stationary application to generate electricity and steam. If steam is not desired, a waste heat boiler and a steam turbine can be added to generate additional electrical power (Walsh, 2004).

The electrical efficiency of a gas turbine operating without a steam turbine is usually less than 30% which is lower than a reciprocating engine. However, if operating in a combined cycle, the electrical efficiency can be over 50%.

1.3.2.3 Steam Turbines

Steam turbines are best suited for use over 10 MWe and may operate with an electrical efficiency of 60% (Leyzerovich, 2007). Siemens offer steam turbines from as low as 45 kWe, but these reduced-size steam turbines operate with a lower electrical efficiency of approximately 20% (Siemens Steam Turbines, 2014). As the use of steam turbines is best suited for sites requiring over 10 MWe, steam turbines are used in power plants transforming a variety of different fuels into heat such as through fossil fuel and biomass combustion, waste incineration and nuclear fission.

1.3.2.4 Fuel Cells

Fuel cells are open system, direct energy converters that continuously and electrochemically convert chemical energy into electricity. Their efficiency can, therefore be higher than that for heat engines. Due to their high efficiency, environmental qualities, high power generation, and relatively simple design, fuel cells are a potential alternative technology for both stationary and transportation applications.

There are many different types of fuel cells. Leaving aside the issue of manufacturing and materials costs, the two main problems with fuel cell are firstly their slow reaction rate, leading to low current and power and secondly hydrogen is not a readily-available fuel. However, fuels like natural gas or methanol can be reformed directly in high temperature fuel cells without using a reformer.

Fuel cell types are usually distinguished by their electrolyte of which five classes have emerged. A summary of these different fuel cells is given in Table 1- 1 (EG&G Technical Services, 2002).

Table 1- 1 Fuel cell types

Fuel cell types	Mobile ion	Operating temperature	Applications and notes
Alkaline – (AFC)	OH^-	50 - 200°C	Used in space vehicles, e.g. Apollo the Shuttle
Proton exchange membrane (PEMFC)	H^+	50 - 90°C	Used for mobile applications and for small scales CHP applications
Phosphoric acid (PAFC)	H^+	~220°C	Large number of 200 kW CHP systems in use.
Molten carbonate (MCF)	CO_3^{--}	600 - 800°C	Suitable for medium to large CHP systems (up to MW capacity)
Solid oxide (SOFC)	O^{--}	600 - 1000°C	Suitable for all sizes of CHP systems, 2 kW to multi-MW

Fuel cells can be considered a mature technology, the PAFC was the first fuel cell type to be produced in commercial quantities. It operates at a fairly high temperature and benefits from a higher electrochemical reaction rate than PEMFC. However, the temperature of operation is not high enough to directly reform natural gas to hydrogen.

1.3.2.5 A Hybrid SOFC Cycle: A Promising System

With today’s concern over the increasing global energy demand and the need to generate clean power, one promising system is the use of a SOFC. As the partial pressure of the fuel in a fuel cell reduces with its progression through the stack, the fuel is never entirely converted electrochemically. However, MCFC and SOFC are able to combust this remaining fuel downstream of the fuel cell. Facchinetti et al. (2011) introduced an innovative concept of atmospheric hybrid cycle combined with oxy-fuel combustion technology and succeeded in achieving 80% electrical conversion efficiencies. This system operates a SOFC at atmospheric pressure, an oxy-combustion unit and two separate gas turbine units driven in an inverter Brayton cycle, see Figure 1- 13.

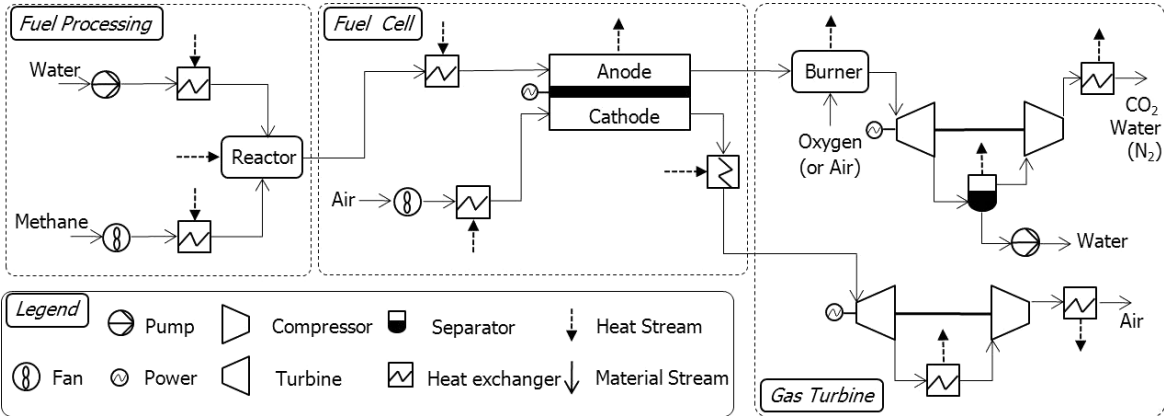

Figure 1- 13 Innovative hybrid cycle flow-chart (Facchinetti et al., 2011)

1.3.3 THERMAL STORAGE

In a hot water storage tank, the generated or captured heat enters at its top and the cooled return flow enters at the bottom. The purpose of a thermal storage system in a DH system is to uncouple the heat generation from the demand and to enable the DH to:

- Meet heat demands greater than the energy plant capacity
- Supply heat from CHP technologies outside their normal economic operating regime
- Meet peaks in demand with a reduced size CHP or low carbon technology
- Operate CHP technologies at times of low daily heat demand (summer load)
- Convert electricity to heat when excess renewable electricity is being generated

1.3.4 DISTRICT HEATING NETWORK

“Extensive research” has been undertaken to minimise DH network operational cost while minimising the heat losses to the soil and the electricity required for pumping (Benonysson et al., 1995, Palsson and Ravn, 1994, Wigbells et al., 2005). This enabled the development of optimisation tools to minimise the operational cost of the DH network.

Commercialised software such as Termis simulates the operation of any DH network configuration: Tree or loop configuration (Termis, 2014). In 2007, Bøhm and Gabrielaitiene (2007) compared the accuracy of Termis with their academic software: DHsim. This

comparison found that DHsim better predicted the DH system's supply flow temperature at far-away consumers. The reason proposed for this was that unlike Termis, DHsim takes into consideration the continuous variation of the supply flow temperature throughout the DH network and the pipes thermal capacity which can store and discharge heat to the DH flow.

Optimising the operation of a DH network can typically reduce the heat losses to the soil by 10% (Schneider-electric, 2014). However, the heat loss per meter of pipe of a DH network is strongly dependent on the DH flow supply temperature and on the insulation and diameter of the DH network pipes but less so on the heat demand and the flow velocity. Hence, DH systems with a line heat density lower than 2 MWh/(m*yr) (DH of low heat density area) have a greater potential to reduce their heat losses to the soil (% terms) by optimising the operation of the DH network. For this reason DH network optimisation would appear to be essential for low heat density DH systems. However, optimising any DH network generally reduces the average supply temperature which may benefit the plant's overall supply efficiency. For example, an EC may generate heat with a heat pump which operates with a higher COP when generating heat at a lower supply temperature.

The line heat density is given by the dimension and length of the DH network pipes and is calculated by dividing the DH annual heat consumption by the length of the DH network (Risoe, 2004). Figure 1- 14 illustrates the typical outcome on the supply and return flow temperatures by optimising a DH network and setting the return temperature at 60°C.

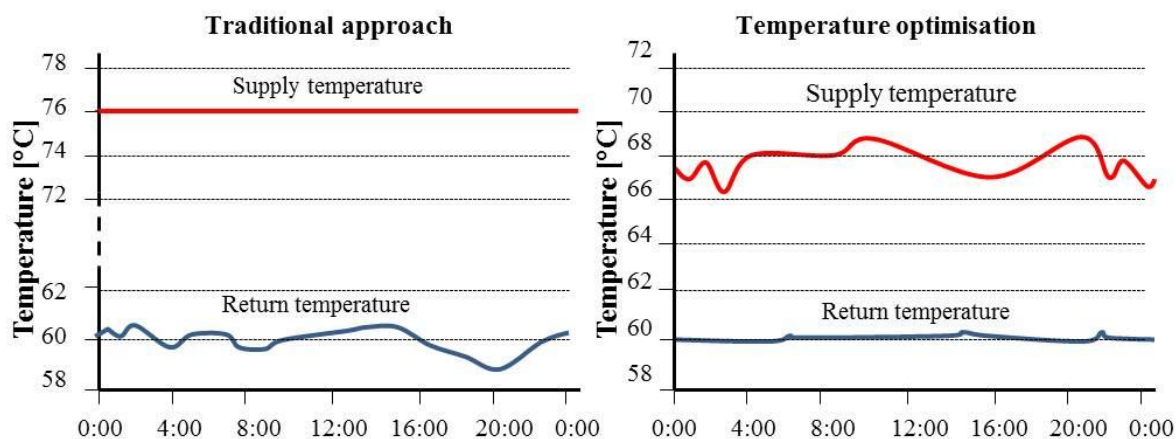

Figure 1- 14 Comparison of the traditional set point supply temperature with a variable supply temperature and flow rate based on predicted demands (Schneider-electric, 2014)

1.3.5 SUBSTATION

Consumers may be directly or indirectly connected to a DH network. A direct connection circulates the DH flow through the consumers' convective heaters. However, due to hygienic considerations, the DHW is never directly connected; e.g. potable water is pumped in London at approximately 12°C (Metoffice, 2013) to a heat exchanger and the DH network heat is transferred to heat the DHW to approximately 60°C. In energy efficient homes, it is usually the DHW that sets the minimum DH flow supply temperature.

Indirect connections may use different types of heat exchangers. The DHW may be heated and stored in a calorifier, but the DH flow may be cooled further by the use of a cross flow flat plate heat exchanger, reducing the DH network pumping cost and heat losses to the soil.

1.3.6 CONSUMER

The use of central heating systems in buildings considerably increased the heating load in our cities during the last 30-60 years, recent improvements in the building regulation have led to buildings becoming more energy efficient partly by demanding less heat. As SH demand is seasonal and its daily profile varies with the building types, DH systems are best suited for mixed-use development with an anchor load; an anchor load is a load above 200 kW (Hawkey, 2009). Consumers have a direct influence on the performance of a DH system. Consumers demand a heat load at a specific temperature; however the consumers' heat demand can be adapted to fit better with DH systems.

The peak heat demand can be reduced, allowing smaller plant to be used and reducing an EC capital cost on supply units' investments. The demand profile can also be flattened throughout a day allowing operation of plant with greater overall efficiency and larger CHP capacity. Both can be achieved by applying "load shifting" strategies and avoiding "night time set-back" discussed here after in Section 1.4.1 and 1.4.2.

.

1.4 DISTRICT HEATING PERFORMANCE

Substantial research has been undertaken to improve the operating performance of a DH system and a summary of the major elements of study is listed below:

- Optimisation of the operation of the energy plant (CIBSE, 2013)
- Reducing the pipe dimensions, length and diameters to reduce heat losses (Risoe, 2004)

- Direct connection and reduction of the total length of service pipes (Risoe, 2004)
- Control of the supply temperature to optimise the economic balance between the relative heat losses and the pumping cost (Risoe, 2004)
- Connecting new housing areas to an existing DH network; only marginal costs for investments in pipe systems and marginal energy costs have to be included. Thus, it becomes profitable to connect areas with low heat densities that normally would not be profitable when the DH has to be built completely from new (IEA, 2008)
- Applying strategies to consumers: Load shifting and night set-back

1.4.1 LOAD SHIFTING AND DEMAND SIDE MANAGEMENT

Demand side management is the planning and implementation of strategies designed to encourage consumers to improve energy efficiency, reduce energy costs, change the time of usage or promote the use of a different energy source (Wernstedt et al., 2007). It comprises of two principle activities: “Load shifting” and “energy efficiency and conservation” (Davito et al., 2010). Thus, the aim of load shifting is to flatten the daily heating load and the financial benefits of applying load shifting strategies are best achieved in the generation of CHP plants; more electricity generation is then possible from the CHP system when the market price for electricity is high.

1.4.2 NIGHT TIME SET- BACK

Werner (2013) confirms that night set-back control can cause significant problems for the operation of DH systems. The issue is controversial because night set-back is associated with reduced heat consumption as many people may wish to sleep at a lower room temperature for comfort reason or to save on heating demand. Werner (2013) discusses that the savings associated with night set-back is often overestimated for two reasons:

1. After the night set-back, a peak heat demand occurs in the morning to increase the indoor night temperatures to the indoor day temperatures.
2. The DH flow is used to heat the buildings to a lower temperature at night and the DH flow returns at a lower temperature. When adjusting the indoor temperatures in the morning, a time delay occurs while the return DH flow is transferred from the consumer back to the energy plant; during this time delay the DH flow returns at the cooler night temperature.

Thus, after night set-backs, the energy plant must supply more heat to raise the indoor rooms to the higher temperature and must do so whilst disadvantaged by the cooler night return temperature. To achieve this, the energy plant must either increase the DH flow rate or the supply temperature. As the flow rate of the generated heat is usually limited by the pumping capacity of the DH network, the increased supply is obtained by simultaneously increasing the supply temperature. However, this may not always be feasible if the energy plant does not have sufficient reserve capacity to do so.

1.5 DISTRICT HEATING AND THE ENERGY SECTOR

1.5.1 DISTRICT HEATING INTEGRATION WITH GRID ELECTRICITY

Since the mid-20th century, the UK has used fossil fuels for heating and transport, with electricity generated by large centralised power plants (National grid, 2012). As part of its aim to reduce national CO₂ emissions, the government is looking to implement a smart grid system to increase efficiency in the evolving energy sector. As shown in Figure 1- 15, a smart grid gives the benefit of making best use of the fluctuating renewable electricity generation. On windy nights or on very sunny days, the extra electricity generated can be stored at all steps of the conversion chain for later use.

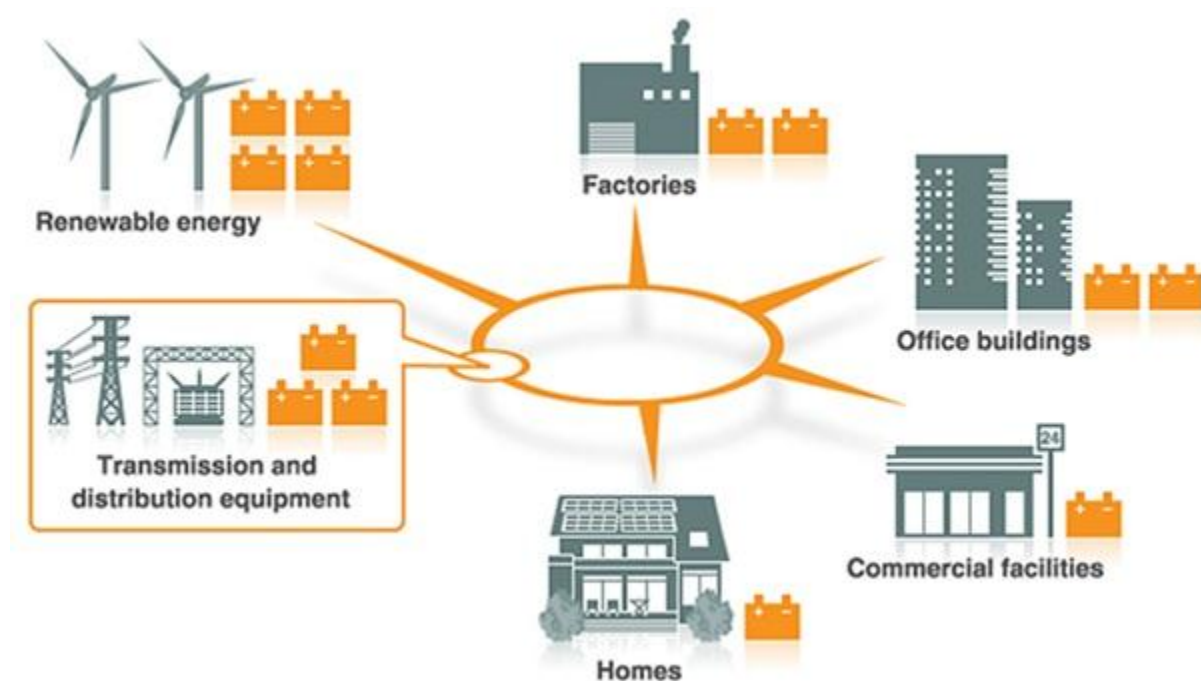

Figure 1- 15 Integration of centralised and decentralised energy generation (CleanTechnica, 2014)

One of the government’s current aims is to reduce CO₂ emissions by generating more renewable and nuclear electricity by 2050. However, this aim could, after 2050, be further developed to transform the UK electrical energy sector to a 100% renewable electricity generation. Figure 1- 16 illustrates a fictitious three day period of UK electricity demand and assumes that electricity would be provided from wind turbines and photovoltaic panels. The figure shows that on windy and sunny days more electricity can be generated than required to meet instantaneous consumer demand and that there will also be periods with no wind or solar, thus no renewable electricity would be generated. A suitable storage infrastructure would enable the requirement of fossil or nuclear power plant generating base load electricity to become redundant.

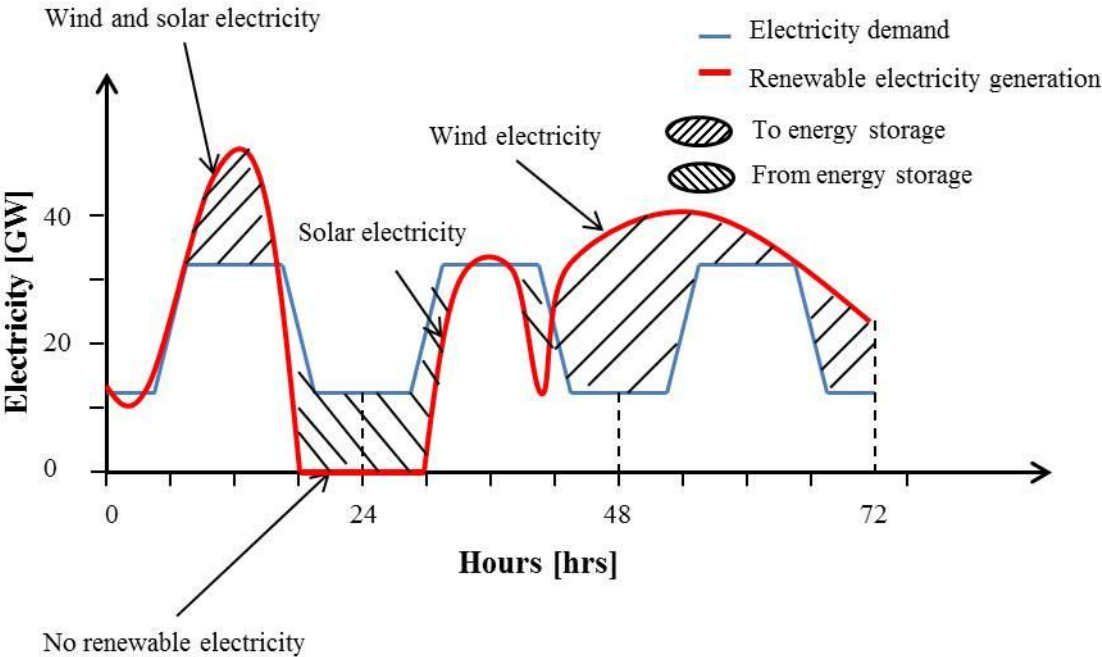

Figure 1- 16 Integration of the renewable electricity generation with storage

Currently, the only significant storage systems are pumped storage systems which are attached to the grid in the UK. Built in north Wales and commissioned in 1984, Dinorwig pumped storage station is the largest in the UK and is of 1,728 MW capacity and can store 9 GWhe (Lowen and Stevenson,1990). Hence, pumped storage systems are hydro-electric stations that can use overnight electricity to recharge their reservoirs. They are mainly used to meet short term peak demands as the water soon runs out. To deal with and mitigate this future required storing infrastructure, the grid could be extended by improving the national and the European electricity distribution.

As discussed, the storing infrastructure is at an early development stage and switching off wind turbines at night is already a major concern in countries such as Denmark and Germany that have a greater installed renewable electricity capacity. However, it also occurs on a smaller scale in the UK. For example, on the 5th and the 6th of April in 2011, wind turbines in Scotland had to be turned off due to the reduced night-time electricity demand (BBC News Scotland, 2011).

1.5.2 DECARBONISED FUEL FOR CHP-DH

To reduce the emissions further, a CHP-DH system will need to integrate RE generation. For example, Sheffield has been generating and supplying heat from waste to a DH network since the 1970's (Veolia, 2014). In the 1980's the DH network was extended and the EC upgraded its waste incinerator to operate in cogeneration with a steam turbine. Although energy from waste is already in use in Sheffield, other RE resources can be employed and are discussed in sections 1.5.2.1 to 1.5.2.4.

1.5.2.1 Solid Biomass CHP

Solid biomass (wood chips or wood pellets) has already found a growing market in small boilers for heating. Wood pellets are compacted small wood chips and sawdust. Solid biomass is currently the renewable fuel that is the most likely to be considered for CHP applications (CIBSE, 2013).

The basic concept of biomass as a RE resource comprises of capture of solar energy and carbon from ambient CO₂ through harvesting and growing crops, which can then be combusted to complete the cycle (Donald, 1998).

Carbon dioxide (CO₂) is converted to organic compound through photosynthesis: Carbohydrate, CH₂O, is liberated with oxygen. CH₂O is the primary organic product and is produced following Equation (1. 1) (Donald, 1998).

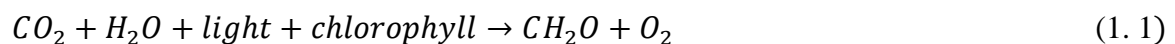

1.5.2.2 Biogas CHP

Biogas refers to a gas produced by the breakdown of organic matter in absence of oxygen. Usually, biogas is then combusted in a modified gas engine to produce electricity and heat. Different techniques to produce biogas from waste or biomass are:

- *Gasification:* A gasification system turns biomass material into a fuel known as synthesis gas or syngas. It involves heating the waste or the biomass with restricted oxygen levels which breaks down the material and releases a syngas (Basu, 2013).
For smaller scale electrical generation, gasification of the waste or the biomass brings higher electrical efficiencies than incinerating the biomass or the waste energy and following a Rankine cycle.
- *Landfill gas:* Landfill waste releases a methane rich gas (Rajaram, 2012). It is created during the anaerobic decomposition of organic substances in municipal solid waste. If landfill gas is allowed to escape to the atmosphere, the methane contained within it acts as a greenhouse gas. By preventing the escape to the atmosphere, biomethane can instead be used as a renewable fuel.
- *Anaerobic digestion:* The process treats organic wastes to produce a biogas that can be used directly in spark-ignition gas engines to produce heat and electricity with part of the heat used to drive the process (Mudhoo, 2012).
- *Pyrolysis:* Pyrolysis involves heating waste or an organic material in the absence of oxygen. This process also produces a syngas, but it can be applied to plants of smaller scale and be more easily integrated with urban DH. Pyrolysis can also be designed to produce a bio-oil (Basu, 2013).

1.5.2.3 Liquid Biofuel CHP

Biofuels are viewed as promising alternatives to conventional fossil fuels because they have the potential to eliminate CO₂ emissions without significantly changing today's energy systems. Engines could remain the technology used for urban transportation with DH-CHP used for heating urban areas. Bioliquids are usually made from virgin or recycled vegetable and seed oils, like palm or soya oil. Currently, bioliquids have been developed to supply energy to vehicles, but are also likely to be well suited for CHP engine applications (Mousdale, 2008). However, there are currently concerns about bioliquids; e.g. the land used for production competes with food crops, the price of this fuel is relatively high, NO_x emissions are higher than for natural gas engines and the energy required to process this fuel is high.

The first and second generation of biofuels had limitations to their development. First generation biofuels refer to the fuels that are derived from sources such as sugars, animal fats and vegetable oil and the biofuel is obtained using conventional techniques of production (Biofuel, 2014a). A second-generation biofuel is produced from plant biomass and refers largely to lignocellulosic materials (Naik et al., 2009). Hence, the second generation of biofuel are not from food crops and are sourced from various types of biomass that can be renewed rapidly (Alprofits, 2014). Although the second-generation biofuels is also known as advanced biofuels, it cannot be used in unmodified engines and the aviation market (Biofuels, 2014a). Although the feedstock for second-generation biofuel can be grown in wastelands and does not affect the human food chain, these feedstock are not expected to be abundant enough to replace more than 20-25% of the world's total transportation fuels (Alprofits, 2014).

The third generation biofuel refers to biofuel derived from algae. Algae produce oil that can be refined into diesel and certain components of gasoline. Algae can be genetically manipulated to produce ethanol and butanol for conversion to gasoline and diesel fuel. Butanol is more similar to gasoline and does not require engine modification the way ethanol does (Biofuels, 2014b). Currently, most algae are cultivated in algae “raceways”. Algae raceways are shallow mechanically agitated ponds that are open to the atmosphere and many researchers (Adenle et al., 2013) consider this technique the most promising for growing algae cultures with a high growth rate and oil content. However, this cultivation method may also have large demands for power, water, CO₂ and nutrients to facilitate algae growth.

1.5.2.4 Biomethane Injection

Although not yet commercially viable, converting the current national gas to biomethane may be a possible alternative to decarbonising the country, Biomethane could potentially be injected into the national gas grid. CHP engines could then continue to use the national gas supply with the added effect of decarbonisation through biomethane injection (CIBSE, 2013).

1.5.2.5 Nuclear

Nuclear energy is attractive for the security of the energy supply and for CO₂ emission reductions. Most current nuclear DH systems are located in the Russian Federation (World nuclear association, 2014). The only other nuclear CHP plant in Western Europe generating significant amounts of district heat is at Beznau in Switzerland: A small proportion of heat

losses from the Beznau CHP power plant is saved and distributed to over 2,300 clients, ranging from small individual houses to large industrial buildings and hospitals (Refuna, 2014).

1.6 DH IMPLEMENTATION

Although DH supplies less than 2% of the UK and European heat demand (Pöyry, 2009, DHC+, 2009), it is very well established in countries such as Denmark and Sweden as well as cities such as Vienna which meet over 60% of their heat demand with DH (Pöyry, 2009). Under the Climate Change Act targets, the UK committed to reduce its CO₂ emissions by 80% by 2050 (DECC, 2009), and London aims to generate 25% of its energy demand from decentralised energy (DE) by 2025 (GLA, 2010). Both drivers favour the implementation of DH. Although DH systems are disadvantaged by their high cost of initial investment and the lengthy payback due to the low income, investors are nonetheless attracted by their longevity as the lifespan of a DH network is approximately 40-50 years (Hawkey, 2009). In addition, Governments are in favour of DH because it can contribute towards various policy goals such as reducing CO₂ emissions, eradicating fuel poverty and securing energy supply (Hawkey, 2009).

As the heat demand in the UK is met by combusting fossil fuels in individual boilers, DH operates in competition with these individual boilers and their fuels (Werner, 2012) and it is not always the most profitable option. Although every DH system is uniquely constructed, DH offers lower carbon abatement costs than conventional technologies and integrates very well to the actual and the forecasted energy sector.

Extra electricity generated from intermittent RE would not be wasted if a nearby CHP-DH is set to give priority to this electricity source by generating and storing heat from it in periods of surplus. This flexible operation of CHP-DH can help to mitigate costs associated with absorbing large quantities of fluctuating renewable electricity generation into the grid (Toke and Fragaki, 2008).

As DH energy plants are smaller scale installations than standard power plant used for the national grid electricity generation, DH systems may benefit from additional governmental incentives including the feed-in-tariff (FiT) and the Renewable Heat Incentive (RHI).

1.6.1 THE FEED IN TARIFF (FIT)

FiT was introduced in April 2010 for small-scale renewable electricity generation so a renewable fuelled CHP-DH, sized less than 5 MWe, could benefit from this scheme. In contrast to the RO, the FiT offers both price and market certainty. FiT payments are given to consumers for the renewable electricity they generate. The aim of the FiT is to help increase the level of RE in view of the legally binding target to generate 15% of the UK's final energy consumption from renewable sources by 2020 (DECC, 2013h); further information on the FiT mechanism is given in Appendix B – Section 3.

1.6.2 THE RENEWABLE HEAT INCENTIVE (RHI)

RHI is similar to the FiT, except it is a financial support scheme for renewable heat instead of renewable electricity. The non-domestic RHI scheme support pays the operator of a DH or heating system a set rate over 20 years for the consumed renewable heat generated. This scheme supports heat pumps, biomass systems, deep geothermal and solar thermal technologies (DECC, 2012, DECC, 2013e).

1.7 DH IMPLEMENTATION IN LOW HEAT DENSITY AREAS

In the UK, 45% of total energy consumption is for heating purposes and 54% of this was consumed by the domestic sector and 19% by the service sector (DECC, 2013g). The current 26 million buildings in the UK (DCLG, 2014) are targeted to be decarbonised by 2050 therefore urban heating loads must reduce. There is a need to assess DH viability in low density areas. The 2008 IEA report demonstrated that DH becomes financially less attractive compared to operating ordinary oil boilers when a DH system line heat density is lower than 0.2 MWh/(m·yr) as shown in Figure 1- 17. However, this calculated breakeven point could be reduced by improving DH system operating performance, reducing their capital cost and by applying taxes on fossil fuel consumption. Figure 1- 17 shows the effect of applying these taxes by comparing the UK and Sweden that have a low and a high fossil fuel taxes policy respectively. Hence, it can be noticed that it is more viable to operate DH systems in Sweden, therefore adding taxes to fossil fuels enhances the viability of DH.

As a DH system line heat density does not increase by adding similar consumers at similar distances and as buildings are becoming more efficient, it has been demonstrated that providing new heating loads to a DH system could compensate this shrinking heating demand (Reidhav, 2008). New heating demands could be obtained from replacing the electricity demand from domestic or non-domestic electrically driven appliances with DH supply, such as for air conditioning, dish washers, washing machines and driers.

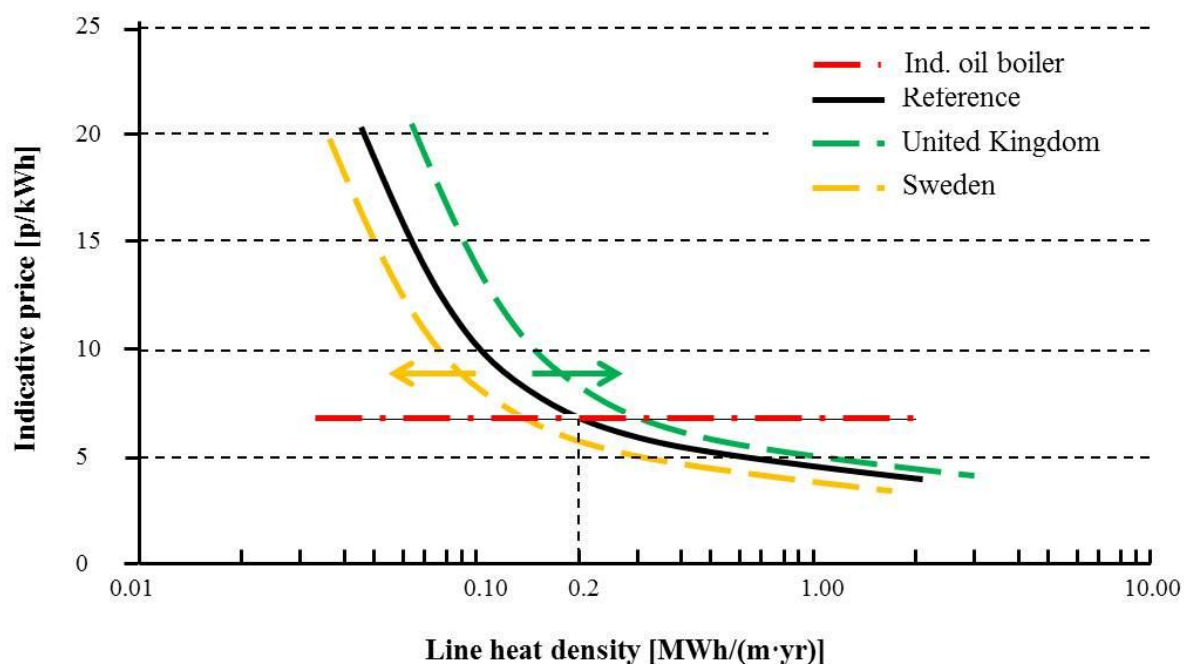

Figure 1-17 District heating compared to individual oil boilers (International Energy Agency 2008)

1.8 THE INDUSTRIAL SPONSOR

Buro Happold is a professional services firm providing engineering consultancy for all aspects of buildings, infrastructure and environment. Its head office is in Bath and was founded in 1976 by Sir Edmund Happold. This thesis was undertaken in collaboration with

the sustainability team, which provides analytical support to global building, masterplanning and management work. The interdisciplinary team includes sustainability, low carbon and environmental modelling consultants who provide expert advice based on extensive technical knowledge and the use and development of advanced simulation software. Research engineers participate in ensuring the team's progression at the cutting edge of sustainable design for the built environment. This gives further expertise to the team to provide advice on procurement and future ready business solutions.

Buro Happold's sustainability team were commissioned by the business group London First to undertake a detailed study into the barriers to delivery of decentralised energy in the capital. The driver for the report was the Mayor's target of 25% decentralised energy by 2025 and 50% by 2050 (GLA, 2007). Buro Happold undertook technical and economic modelling to establish key financial incentives that would support implementation.

As decentralised energy is a fundamental solution in retrofitting projects and new built development, many projects require understanding of DH. DH is not often studied in UK Universities and not many engineers have got profound knowledge of it. As Buro Happold is concerned by this and by DH systems operating very poorly in the UK, Buro Happold agreed in undertaking a thorough investigation assessing the operational performance of DH systems with the collaboration of a Research Engineer from Loughborough University: Oliver Martin-Du Pan.

2 OVERARCHING AIMS AND OBJECTIVES

2.1 BACKGROUND TO OVERARCHING AIM AND OBJECTIVES

The use of DH dates back to Roman times: Hot water was used and circulated in open trenches to heat the traditional communal baths and buildings (Kolanowski, 2011). District electrification started in 1882 with Thomas Edison in New York when he constructed an electric generating plant in two buildings in lower Manhattan (Tagliaferro, 2003). From that time until the beginning of the twentieth century, electrical power generation was in its early stage and most industries had to generate it themselves because the grid was undeveloped. As the dominant technology then was the reciprocating steam engine, waste heat was simultaneously also generated and was sometimes also used to heat the premises (Kutz, 2007). Benefitting from an increasing demand and decreasing fuel costs, the electrical power industry grew rapidly due to reducing costs and industrial companies abandoned their own heat and power generation (Kutz, 2007). Following the 1973 oil crisis (Venn, 2002), industrial companies and the governments like Denmark, which were 99% dependent on foreign oil in 1973, re-considered the benefits of cogeneration by developing an alternative-energy policy (DEA, 2012). To become less dependent on fossil fuel, Denmark had to generate heat and electricity more efficiently. DH systems were installed throughout the country to enable this greater efficiency and now over 63% of all homes in Denmark are heated by DH (IEA, 2011b).

The challenge of operating a DH system is to determine what kind of heat supply unit should be used and what should be the optimum water temperature levels (Benonysson et al., 1995).

The latter task is very challenging because of the simultaneous dynamics occurring in DH systems which are:

- The heating load
- The time delay to supply the heat to the consumers
- The supply unit thermal efficiency variability with the generated heat temperature output

DH network simulation methods were developed using the Node Method to simulate the operation of DH networks.

The Node Method is used to record in time steps when a mass of water arrives at a node and at a consumer of the DH network. Because of the slower nature of computers in the 1990, DH network simplification by aggregation of its components was necessary to obtain quick simulation results for daily scheduling. A simplified model reduced the number of components in the model by aggregating branches and nodes which corresponds in real life to the pipes and the consumers of a DH network.

This aggregation development of a DH network was developed and used for approximately 15 years from the 1990s and was based on two main aggregation methods that were independently developed in Denmark and Germany (Risoe, 2004). Both methods aggregate the branches of a DH network in a similar way, see Figure 2- 1. As shown, the shorter branch with its node is aggregated to the longer branch by becoming an additional node.

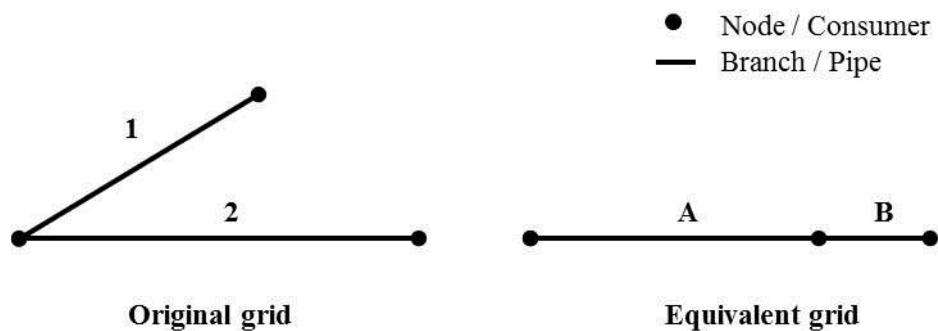

Figure 2- 1 An illustration of how a tree structure is converted into an equivalent line structure

The main difference between the German and the Danish methods is to remove branches of the DH network model and is illustrated in Figure 2- 2. The German method removes a node by replacing two branches by one whereas the Danish method removes a branch replacing three branches by two.

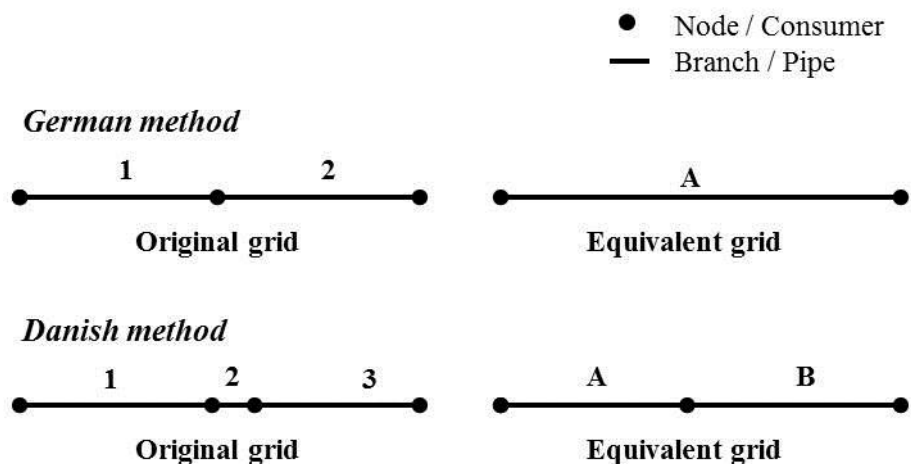

Figure 2- 2 An illustration of how branches can be removed

As a DH system is composed of four components with the energy plant generating the electricity and/or heat, other software such as EnergyPro were developed to simulate the operation and management of a cogeneration plant (energyPro, 2012). EnergyPro is a software package for combined techno-economic analysis and optimisation of both cogeneration and trigeneration projects. It can simulate the operation of an energy plant with or without the use of an accumulator and the user is able to input a wide range of data, such as the annual heating load data time series with a 15-minute time interval.

With increasing enthusiasm by a range of governments about DH, researchers have investigated the viability of DH in low heat density areas. The International Energy Agency published a report entitled “*District heating for energy efficient buildings*” in 2012 (IEA, 2011a). Although some governments are in favour of DH, the implementation of DH systems are disadvantaged by the following two associated risk factors (Woods and Davies, 2009):

- **Fuel supply:** As a DH system usually transforms a primary fuel to heat, and subsequently pumps this heat to consumers, a DH system’s viability is dependent on the cost of fuel and the net cost of generated heat. For this reason the generated heat cost can only be minimised by DH operators with the constraint that fuel costs are recovered.
- **Take-off:** Connection of 100% of possible consumers connected to a DH system will never be achieved without mandating the population to connect to it. However, a DH network is said to have taken-off when the number of consumers connected to the DH network rises at a quick rate. Take-off is an essential parameter for a DH network, because delays in take-off will delay satisfactory income from the DH network, and

delay revenue recovery in the early years. Moreover, a delay in take-off could result in a DH system being oversized leading to the system underperforming. Indeed, one of the complexities in a DH project is to balance the size of a DH network between the initial base load and the potential future load.

To address these risk factors and to improve DH systems implementation, Woods (2013) wrote: *“Whilst an incentive for gas-fired CHP would be welcomed it may be better to incentivise DH through DH Incentive that would make payments retrospectively on an annual basis according to the amount of CO₂ saved. This would encourage DH operators to develop lower CO₂ forms of heat production and design efficient networks. In return for the DH Incentive they would have an obligation to provide data on their scheme on energy and CO₂ emissions which would be made publicly available to aid designers and policy makers”* (Heat 2014 Blog, 2014).

Although DH system is today considered a mature technology, every DH system is currently still uniquely constructed and none of the literature reviewed as part of this thesis discusses in detail the operational performance assessment of a DH system. This is a research gap worth investigation because DH systems frequently operate inefficiently.

2.2 OVERARCHING AIM

This thesis is intended to provide information for academics, researchers, government officials, DH system operators and consultants so that they can better understand the

operation of DH systems. It is believed that an operational performance assessment can give a valuable insight into the technology and can open new avenues for development. Engineers do have access to existing DH manuals such as the AM12: Combined heat and power for buildings (CIBSE, 2013), however, the UK government is aware that DH systems are not operating as intended and emitting greater CO₂ emissions than if the site was operating with traditional individual boilers. In fact, current DH systems in the UK may operate with 40% of heat losses to the soil with their supply units efficiencies being lower than 65% instead of 100% based on the low heating value (LHV). With this in mind, the aim of this Engineering Doctorate was to investigate and develop a method to optimise the overall energy efficiency of DH systems.

2.3 OBJECTIVES

As the primary objective of this thesis was to assess the performance of a DH system to reduce its CO₂ emissions compared to the baseline, the former assessment compared the primary fuel consumed by a DH system with its final electricity and/or heat generated and consumed heat. A DH system is composed of four semi-coupled components influencing its overall performance, therefore the four following objectives were defined:

Objective 1: To undertake assessments of existing DH systems to determine their energy consumptions and losses.

Objective 2: To determine how to minimise the energy losses for each component in a DH system individually.

Objective 3: To determine how to minimise the overall losses of a DH system.

Objective 4: To develop a method to optimise a DH system with respect to CO₂ emissions, heating cost and exergy efficiency.

2.4 JUSTIFICATION OF THE OBJECTIVES

Many engineers believe that DH is a good solution to reduce the CO₂ emissions and the heating cost, however this is not always the case. Occasionally, a DH system increases the heating cost and the CO₂ emissions compared to operating individual oil or natural gas boilers. The operational performance assessment of a DH system is currently a research that has not yet been explored in sufficient detail. Private companies store data but do not have enough time to analyse them thoroughly and the data are usually only used for billing purposes. The reasoning behind the objectives outlined in Section 2.3 are:

Justification 1: To obtain planning permission, consultancies need to assess the CO₂ emissions from a DH system project and to compare it against the UK baseline. As the current guidance to assess the operation of a DH system is not yet regulated, engineering consultancies and DH systems operators usually assume that DH systems operate with a 10% of heat losses to the soil and that the supply units operate with a seasonal efficiency of 85% (DECC, 2013d). This thesis gives consultancies the opportunity to improve the use of data and benchmarks for the benefit of better assessing DH projects.

Justification 2: As the overall performance of DH systems is directly influenced by the performance of four DH components, the dynamic and seasonal performance of each component must be investigated to prioritise their most efficient operational mode.

Justification 3: A DH system is dynamic. It is composed of four semi-coupled components and the different operational mode of one component could have a negative or positive effect on another component. For this reason, the overall seasonal and dynamic performance of a DH system is investigated.

Justification 4: Commercialised software can currently optimise a DH system energy plant, a DH network and a consumer energy demand but no software is able to optimise the four components of a DH system simultaneously. Hence, a scientific methodology is needed to assess the performance of a DH system.

3 RESEARCH METHODOLOGY

3.1 INTRODUCTION

This chapter summarises the applied methodology to assess the operational performance of a DH system. This methodology provides a systematic route for conducting the research and addresses the research objectives outlined in Section 2.3.

The difference between applied research and experimental research design was investigated by Roberson (2011). He confirmed that the manipulation of a single variable under laboratory conditions is not consistent with performance in the “real world” due to the larger number of complex variables. In 2008, Hua discussed that although the analysis of a case study are bounded and cannot be generalised, they can provide significant insights into events and behaviour while increasing the understanding of a phenomenon (Hua, 2013). Hence, a combination of a case study approach and a simulation approach (using the monitored data from the analysed case studies) were undertaken to analyse the operational performance of DE systems. The flow diagram in Figure 3- 1 illustrates this methodology.

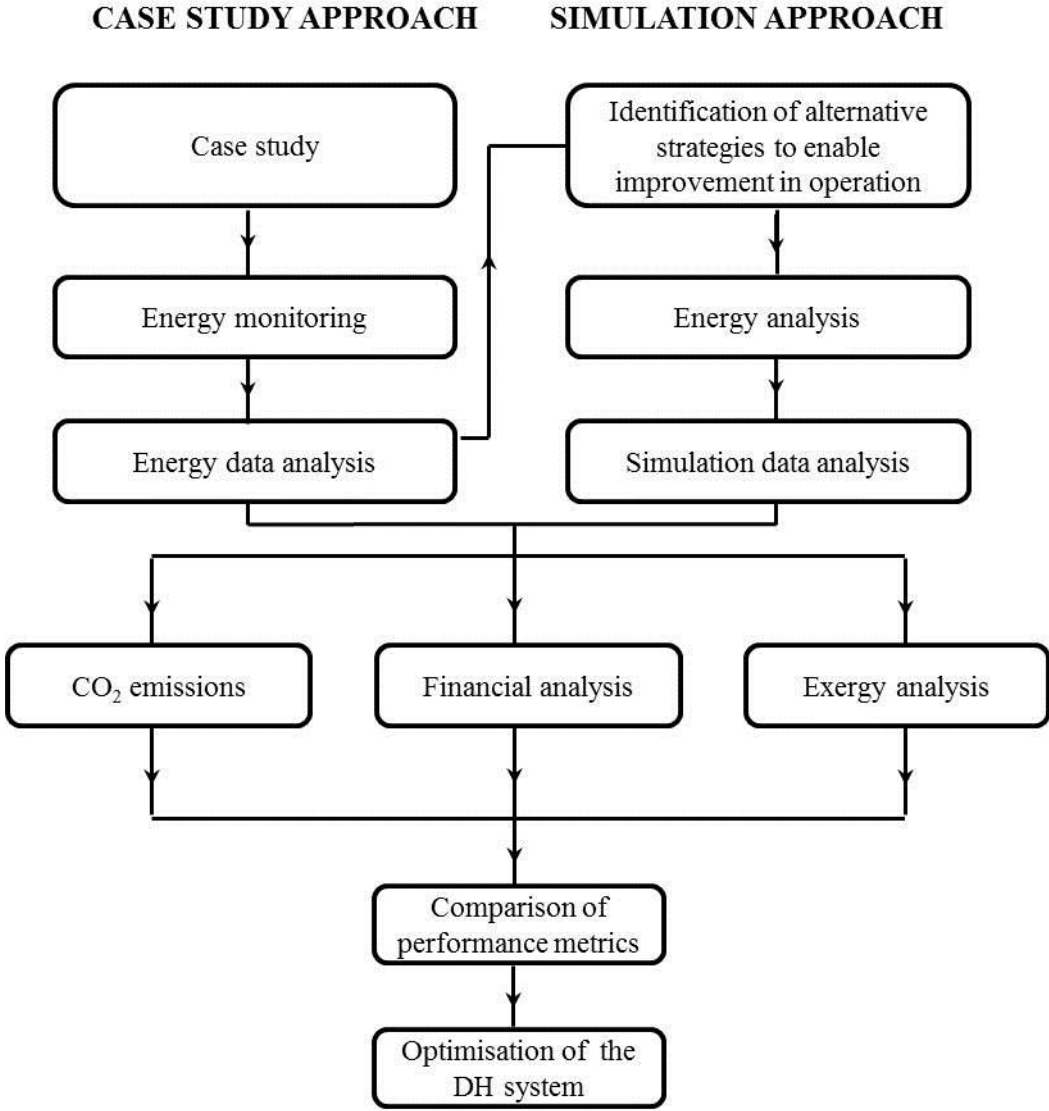

Figure 3- 1 A flow diagram of the adopted methodology

As shown, the two approaches converge towards analysing the CO₂ emissions, financial analysis and exergy efficiency. The case study approach assesses the current operation of an existing DH system, whereas the simulation approach uses the monitored data from the current operation and simulates different scenarios, for example changing the main supply unit. The case study approach is required to understand current operation of the plant, and the simulation approach quantifies the benefits that can be obtained from applying different

operational strategies. The obtained benefits are also quantified with regard to CO₂ emissions, heating cost savings and exergy efficiency.

3.2 METHODS EMPLOYED

Four case studies were analysed as shown in Table 3- 1, a literature review and energy surveys were undertaken on each case study. The monitored data from each energy survey investigation was used to perform the four following analyses of performance metrics also detailed in the table:

- Primary energy analysis
- CO₂ emissions
- Financial analysis
- Exergy analysis

Table 3- 1 Summary of the methods/tools used in each case study

	Elmswell DH	Strand Palace Hotel	Loughborough University DH	Pimlico DH Undertaking
Literature review	√	√	√	√
Case study and simulation approach	√	√	√	√
Walk-through audit	√	√	√	√
Meter reading	√	√	√	√
Equipment level power demand monitoring				√
Energy surveys		√		√
Energy centre		√		√
DH network	√		√	√
Substation				√
Consumer	√	√	√	√
Operational management of DH	√	√	√	√
Energy analysis	√	√	√	√
Performance assessment metrics	√	√	√	√
CO ₂ emission analysis	√	√	√	√
Financial analysis		√		√
Exergy analysis				√

3.2.1 LITERATURE REVIEW

A literature review was carried out throughout the EngD to address the specific needs of each study. Chapters 1 and 2 provided an overview of the literature review of DE and DH with each publication in the Appendices including more specialised literature review. Finally, additional literature review was undertaken for the analysis of each case study.

Elmswell and Loughborough University DH required a literature review of research into the optimisation of a DH network (Appendix A1 – Section 2.4). As Elmswell DH generates heat with a biomass boiler, the literature review compares work detailing the generation of electricity and/or heat with different supply units and resources.

The economic and CO₂ emissions benefits were analysed for the Strand Palace hotel. The Strand Palace hotel generates 90% of its electricity consumption using two 250 kWe CHP engines. As part of this analysis, a literature review focused on the drivers to achieve a low carbon economy for the UK was undertaken and is discussed in Appendix B. This literature review was completed by a literature review on the different possible financing methods to purchase and maintain a decentralised technology.

Pimlico District Heating Undertaking (PDHU) required a review of additional technical literature, for example to find out the accuracy of heat meters and ultra-sonic flow meters; this is discussed in Appendix C – Section 3.4.1. As PDHU supplies heat to 3,256 residential properties, the operators must guarantee that heat is generated in a cost effective way to minimise heating costs and to reduce the number of fuel poor households. Literature on fuel poverty was reviewed (Boardman, 2010).

3.2.2 CASE STUDY AND SIMULATION APPROACH

As illustrated in Figure 3- 1, the energy surveys for the case study and simulation analyses were undertaken in seven different steps discussed below:

a) Case study selection

Case studies were selected after meeting with DE system operators and determining the extent of their monitoring equipment as the aim of this research is to undertake an operational performance assessment of DE and DH system. Different scales of DH system were selected to assess the performance of a DH system relative to their line heat density.

b) Energy consumption and generation monitoring

Monitoring of energy consumption and generation was undertaken based on the available monitoring equipment. For most case studies, energy consumption and generation data were acquired by going on-site and reading data from installed metering equipment. The energy consumption and generation figures, for a defined time period were then calculated by subtracting the later values from the early ones. Some systems benefitted from automatic meter reading (AMR) allowing the monitored data to be accessed remotely. All case studies used Class 2 heat meters in the energy plant and at the consumers. These heat meters have a permissible error of 5% (GasTec, 2010).

c) Component performance assessment

Every component seasonal performance of the DH system was calculated if possible. This was achieved by reading the energy consumption and generation values on a monthly basis and dividing the energy generated by the energy consumed. If the system benefitted from AMR logging the energy consumption and generation, based on these 30 minute

readings, quasi-dynamic efficiencies could then be calculated by dividing the energy produced or coming out of a component with the energy consumed or coming in.

d) Global analysis of a DH system

Using the energy consumption and generation data for each system, an analysis of energy, CO₂ emissions, financial and exergy was performed for the full system.

e) Analysis of different strategies to modify performance from the current operation

To investigate the benefit of a different operational model for the plant, different operating strategies were identified and simulated using the same heating loads to those measured in the current operation but setting the heat to be supplied at a minimum temperature of 10°C above the end-users' maximum required temperature, usually the DHW which was heated to either 55 °C or 60°C.

f) Simulation

As a time resolved heating load profile is necessary to undertake a detailed simulation, simulations were only undertaken for DH systems benefitting from AMR at the consumers and/or in the energy plant enabling measurement of energy consumptions data at hourly or half-hourly intervals.

To guarantee that heat is supplied and consumed at a high enough temperature, the simulations assumed the DH flow to be cooled to a similar temperature to that for the current operation.

g) Global analysis of each simulation

With the energy consumption and generation results, an analysis of CO₂ emissions, heating cost and overall exergy efficiency was undertaken.

3.2.3 ENERGY SURVEYS

A DE system usually benefits from installed heat and/or electricity meters. Thus, energy readings for the accumulated energy generated and consumed is usually possible. For billing purposes, all consumers also have heat and/or natural gas and electricity meters. These meters enable the option to undertake daily or monthly readings. Some case studies systems benefited from AMR with the logged data saved on a 30-minute time interval.

3.2.3.1 Walkthrough Audit

A walk-through survey is typically the first step in any energy audit. It consists of an exploratory site visit to visually inspect each of the energy using components (Thumann,

2009) and identify the equipment contributing to the overall energy efficiency of the DE system.

3.2.3.2 Heat and Electricity Meter Reading

Meter readings provide valuable information regarding consumption of energy over a given period of time. Seasonal efficiencies can be obtained by monitoring on monthly time interval the energy consumption and generation. As a DE system does not operate at a constant load throughout a monitored season, a quasi-dynamic analysis was also undertaken. The quasi-dynamic analysis was carried out by sub-metering at shorter intervals (typically half-hourly) the major appliances involved in the system. Such an analysis is made easier with AMR, which allows simultaneously logging of the energy consumption and generation of different energy units. Quasi-dynamic operation calculations were then validated by filtering any invalid data, e.g. the data when the supply units were modulating or in start and stop cycling.

3.2.3.3 Power Demand at Individual Equipment Level

The parasitic electricity consumption from supply units is usually neglected. However, this electricity consumption was investigated by measuring and monitoring it at individual equipment level through the use of plug monitors with logging capabilities. These monitoring devices can measure and record power demand at time intervals of 1-minute, they have however limited internal memory capabilities.

3.2.3.4 Energy Centre (EC)

An EC generates electricity and/or heat. To generate this energy and pump the heat to the connected consumers, a supply unit converts a primary fuel to heat and/or electricity and some parasitic and pumping electricity is consumed to activate the supply units and to pump the DH-flow to the consumers.

Supply units

A supply unit converts a primary energy, such as natural gas, to generate heat and/or electricity. Losses occur from this conversion and some parasitic electricity is consumed to pump the fuel, the oxidant and to power the combustion process.

Conversion loss

A conversion loss is the difference between the primary energy coming in and leaving an energy converter over a period of time. Seasonal and quasi-dynamic conversion losses were calculated. Quasi-dynamic conversion losses were calculated using the monitored 30-minute data. However, filtering of this half-hourly data recorded over a year was necessary to erase data when supply units modulate or operate in start/stop cycling giving transient values.

Parasitic electricity

The varying parasitic electricity consumption was measured at individual equipment-level when operating at a known load.

Heat losses

Pipes in an EC are usually insulated and are of negligible distance compared to the DH network length. For this reason, their heat losses were neglected in this study. However, an EC is very often fitted with a thermal store that is not perfectly insulated and some heat is lost to the environment. As the heat lost from a thermal store is dynamic and dependent on its fluctuating use, a quasi-steady-state performance was not calculated, but its seasonal performance was calculated using Equation (3. 1).

$$\eta_{Acc.} = \left[1 - \frac{Q_{Acc}^+ - Q_{Acc}^-}{Q_{Acc}^+} \right] * 100 \quad (3. 1)$$

Electricity required for pumping the district heating flow

Electricity is consumed to pump the DH flow and supply the heat to the consumers. As a DH system usually supplies heat in variable amounts and temperatures to multiple legs of a DH network, it is very challenging to assess the electrical power required for pumping. For this reason, the electrical power supply consumption to pump a known amount of heat to the DH network was calculated by subtracting the parasitic electricity consumed by every supply unit

to the EC total electricity consumption. Thus, the electricity required for pumping and the supplied heat can be calculated throughout the year on a 30-minute interval basis with Equation (3. 2) and Equation (3. 3) respectively. Equation (3. 3) adds the heat generated from each supply unit and the difference between the discharged and stored heat to the thermal storage.

$$\Psi = E_{Total}^+ - \sum_{Supply.unit=1}^n (E_{Sup.}^+)_{Supply.unit} \quad (3. 2)$$

$$Q_{DHN} = (Q_{Acc.}^- - Q_{Acc.}^+) + \sum_{Supply.unit=1}^n Q_{Supply.unit} \quad (3. 3)$$

3.2.3.5 District Heating Network

Although friction, thus heat, occurs from pumping water through a pipe, the heat losses to the soil from a leg of a DH network was calculated by subtracting every connected consumer's monitored heat consumption to the leg's calculated heat supplied.

The heat supplied was calculated after monitoring the instantaneous flow rate of the supplied water with an ultra-sonic flow meter (GE Sensing, 2005) and monitoring the temperature of the supply and return steel pipe with thermocouples (MicroDAQ, 2013). With this information, the heat supplied could then be calculated with Equation (3. 4). Hence, seasonal and quasi-dynamic heat losses to the soil could be calculated by subtracting the aggregated heat consumed from the heat supplied by the DH network.

$$Q_{DHN}(i) = \int_{t=0}^{5 \text{ min.}} \dot{m}(i) * C_p * (T_{Sup}(i) - T_{Ret}(i)) dt \quad (3.4)$$

3.2.3.6 Substations

As Substations usually exchanges heat at nearly 100% efficiency, monitoring of heat losses at substations was neglected in this research. However, as substations downgrade the supplied temperature and thus exergy, an exergy analysis was conducted by assessing the temperature drop between the DH network and the end-user consumed heat temperature, for example the DHW.

3.2.3.7 Consumer

With the use of a thermal storage, the energy generation can be decoupled from the consumers' heat demand. This can enable the EC to generate heat at a more constant rate throughout the day. Consumers may also influence the heat load by reducing and flattening their heat demand throughout the day by:

- Applying load shifting strategies.
- Improving the building envelope and reducing the heating demand and supply temperature required.
- Including a thermal storage for the DHW and reducing its temperature while preventing an outbreak of Legionnaires' disease by ensuring that the system is properly maintained.

- Avoiding night set-back and improving the system operation by avoiding morning peak heating load.

3.2.4 OPERATIONAL MANAGEMENT

The operational management of a DH system determines the operation of the supply units and the use of the thermal store if present. If the energy plant operates with a single supply unit and no thermal storage is in use, the operational management will set the supply unit to modulate with the heating demand. However, energy plant usually operates with multiple supply units to firstly ensure the reliability of the system in case of breakdown and maintenance of the primary supply unit. Secondly, the primary supply unit may be a low carbon technology, usually sized to meet the base heating load demand to improve its operating seasonal efficiency, to reduce its capital cost and obtain a better payback.

The operational management of a DH system was assessed by:

- Monitoring the energy generated by each supply unit
- Investigating the supply units' energy generation efficiencies and their numbers of start/stop operation
- Investigating the use of the thermal storage

3.2.5 PERFORMANCE ASSESSMENT METRICS

3.2.5.1 Energy Analysis

Aggregated annual, monthly, daily and half-hourly energy consumption figures (in kWh or MWh) were utilised in this research project. These were acquired via periodic meter readings or by AMR. These figures were used to assess the quasi-dynamic and seasonal performance of a DE system and were calculated using Equation (3. 5). This equation divides the total energy generated by the primary energy consumed from the system or sub-system. The primary energy does not include parasitic electricity consumption.

$$\eta = \frac{\textit{Total energy out}}{\textit{Primary energy in}} = \frac{E^- + W^- + Q^-}{E^+ + W^+ + Q^+} \quad (3.5)$$

3.2.5.2 CO₂ Emissions Analysis

In the UK, natural gas is commonly the primary fuel used for the heating sector as individual natural gas boilers are usually used to heat dwellings or offices. Building regulations Part L 2013 acknowledges this, so when a DH system is assessed, the practitioner compares its operation to a baseline, which assumes a similar amount of consumed heat to be generated by individual natural gas boilers operating with a seasonal efficiency of 85%. If the DH energy plant also generates some electricity, the equivalent amount of electricity is assumed to be provided from the national grid. The baseline does not consume electricity to pump the heating flow and does not have any heat losses to the environment as shown in Figure 3- 2.

As grid electricity in the UK has a high carbon intensity factor, operating an energy plant in cogeneration while consuming natural gas reduces the national CO₂ emissions. To calculate the DH system CO₂ emissions and possible CO₂ reduction, SAP 2012 carbon factors were used and are given hereafter (DECC, 2013d):

- Natural gas: 0.216 kg CO₂/kWh
- Wood pellet: 0.039 kg CO₂/kWh
- Elec: 0.519 kg CO₂/kWh

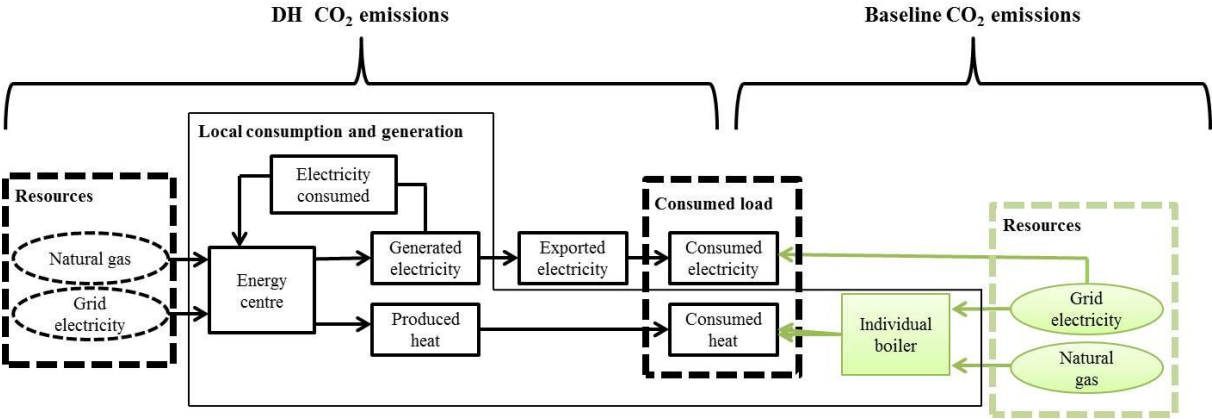

Figure 3- 2 DH system CO₂ emission compared to the UK baseline

3.2.5.3 Financial Analysis

The financial analysis of a DH system is dependent on the following three parameters. Firstly, the cost of financing new equipment varies with every contract and also depends on the repayment term. Secondly, a particular technology at a given time may benefit from governmental financial incentives. Finally, a DH system generates electricity and/or heat while consuming a primary energy resource; thus the DH system is dependent on this

resource and is in competition to the baseline that operates natural gas boilers. Taking into consideration these factors, two different types of financial analysis were undertaken to assess the viability of a DE technology:

- a) The operation cost saving
- b) The payback

a) Operational cost saving

The operational cost saving is calculated with Equation (3. 6). It is calculated by subtracting the scenario operational cost from the baseline. Note that the baseline will be different for an existing and a new DH system as described below:

$$C_{Saving} = C_{Baseline} - C_{Scen} \quad (3. 6)$$

Baseline operational cost

- **For an existing DH system**, the baseline is the current operation of the plant. Operational cost is calculated with Equation (3. 7). This equation includes the energy resource consumed to generate the electricity and/or heat, the energy plant maintenance cost and the income from exporting electricity.

$$C_{Baseline} = (C_{Res})_{Baseline} + (C_{Maint})_{Baseline} - (C_{Income_elec})_{Baseline} \quad (3. 7)$$

- **For a new DH system**, the baseline is based on Part L 2013 (DECC, 2013d): It assumes the heat to be generated by individual natural gas boilers operating with a seasonal efficiency of 85% and the electricity is provided by the grid. As the individual boilers maintenance costs are neglected in this thesis, Equation (3. 7) reduces to Equation (3. 8).

$$C_{Baseline} = C_{Resource} \quad (3. 8)$$

Scenario operational cost

The operational cost for a new and/or existing but upgraded DH energy plant is calculated with Equation (3. 9). It includes the annual cost of the primary energy resource consumed, the maintenance cost, the financing cost and if relevant the income from exporting electricity.

$$C_{Scen} = (C_{Res})_{Scen} - (C_{Income_elec})_{Scen} + (C_{Maint})_{Scen} + (C_{Repay})_{Tech} \quad (3. 9)$$

b) Payback assessment

A DH operator may decide to invest significantly in purchasing a new technology for a reduction in heating cost. For this reason, before investing in a new technology, a DH operator assesses its viability by calculating the potential operational cost saving and the payback of the new technology. The payback in number of years is calculated using

Equation (3. 10) and divides the capital cost of the new technology by the annual associated cost savings using Equation (3. 11).

$$\mathbf{Payback} = \frac{\mathbf{Capex}}{\mathbf{C}_{Saving}} \quad (3. 10)$$

$$C_{Saving} = C_{Baseline} - (C_{Res})_{Scen} + (C_{Incomeelec})_{Scen} - (C_{Maint})_{Scen} \quad (3. 11)$$

An Energy Service Company (ESCO)

Operators usually do not have the capital to purchase DE technologies such as CHP engines and may prefer to make an alternative funding arrangement with an ESCo. Although ESCo arrangements vary greatly, they are based on supplying heat and electricity to the operator for a fixed term (typically 10 to 15 years). Usually, the operator becomes the owner of the plant at the end of the agreement period. The drawback of having such an arrangement with an ESCo is that the benefits are shared because two parties are involved. As the ESCo purchases, installs and maintains the DE technology the net operating income cannot be assessed in the same way for the two parties. In the case of a CHP engine, the operator can quantify its operational cost savings with Equation (3. 12). This equation calculates the resource energy consumption saved, the income for the electricity generated and subtracts the agreed ESCo cost. The agreed ESCo cost can be calculated with Equation (3. 13) or Equation (3. 14). Equation (3. 13) calculates the cost of operating the energy plant with a CHP engine, the repayment cost for the installation cost of the CHP engine and the additional cost from the service provided by the ESCo, whereas Equation (3. 14) calculates this cost as provided by the ESCo agreement contract. As an ESCo agreement contract guarantees the operation of the

CHP engine to generate a fixed amount of electricity that the ESCo will invoice; the additional electricity generation is usually free of charge for the operator. This fixed amount of electricity that an ESCo invoices is referred as the “intake”.

$$C_{Saving} = C_{Baseline} - (C_{Res})_{ESCo_Scen} + C_{gen_elec} - (C_{Agr_contract})_{ESCo} \quad (3.12)$$

$$(C_{Agree.contract})_{ESCo} = (C_{Maint})_{Plant} + C_{Repayment} + \mathbf{Additional} \quad (3.13)$$

$$(C_{Agree.contract})_{ESCo} = \mathbf{Annual\ intake\ of\ electricity\ generation} \quad (3.14)$$

As it is the ESCo that invests in the DE technology and maintains it rather than the operator, the payback is calculated from the perspective of the ESCo using Equation (3.15). This equation divides the installation cost by the agreed annual intake from the CHP engine electricity generated reduced by the maintenance costs. The agreed intake is usually equivalent to a CHP engine operating at maximum load for approximately 4,000 hours. The conference paper in Appendix B discusses this and also expands on the maintenance cost.

$$Payback = \frac{Capex}{(C_{Agr_contract})_{ESCo} - C_{Maint}} \quad (3.15)$$

3.2.5.4 Exergy Analysis

Exergy is defined as the theoretical maximum work which can be obtained from each energy unit and the overall system, (Borel and Favrat, 2010). The sources of energy can be divided into two groups: High and low grade energy. The conversion of high grade energy to shaft work such as electrical energy is exempted from the limitations of the second law of thermodynamic that states that in a natural thermodynamic process, there is an increase in the sum of the entropies of the participating systems (Borel and Favrat, 2010). Josiah Willard Gibbs (1839 – 1903) was accredited with being the originator of the availability of energy concept by indicating that the environment plays an important part in evaluating the available energy (Nag, 2002) and according to Favrat et al. (2008) the exergy approach allows us to quantify in a coherent way, both the quantity and the quality of the different forms of energy considered.

Compared to other definitions of efficiency, the exergetic efficiencies are never bigger than 100% and are compatible with all cases of energy conversions for all energy services. It indicates the relative quality of the conversion and therefore different technologies can be compared. As illustrated in Figure 3- 3, a clear set of system boundaries needs to be drawn in order to define the exergy indicator.

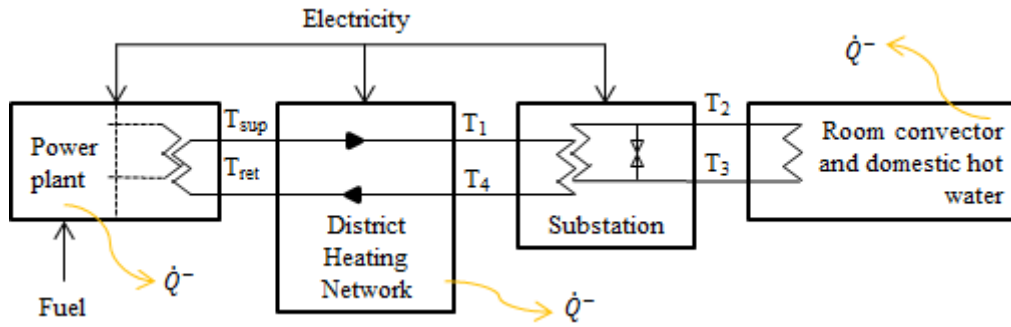

Figure 3- 3 DH system boundaries at T_{ref} and P_{ref} (Favrat et al., 2008)

Assuming a constant atmospheric temperature, the overall exergy efficiency of the defined systems can be calculated using the definition Equation (3. 16), where η is the exergy efficiency, \dot{E} is the mechanical and electrical work, \dot{E}_q is the heat exergy and \dot{E}_y is the transformation exergy.

$$\eta = \frac{\sum \dot{E}^- + \sum \dot{E}_q^- + \sum \dot{E}_y^-}{\sum \dot{E}^+ + \sum \dot{E}_q^+ + \sum \dot{E}_y^+} \quad (3. 16)$$

In Equation (3. 16), all terms are positive, differentiating between the terms entering the system with “+” sign and the positive terms (services) delivered by the system with a “-“ sign.

- \dot{E}_q^+ is the heat exergy and can be calculated with Equation (3. 17). θ is the Carnot Factor and is equal to $\left(1 - \frac{T_a}{T}\right)$ and \dot{Q} is the rate of heat transfer.

$$\dot{E}_q^+ = \int \theta \delta \dot{Q}^+ = \int \left(1 - \frac{T_a}{T}\right) \delta \dot{Q}^+ \quad (3.17)$$

- The transformation exergy \dot{E}_y^+ groups the transformation exergy of material flows entering or leaving the system. This term groups the network of fluids which come into direct contact with each other. Heat exchangers link two networks and therefore involve two transformation exergy terms. The exergy value of the fluid in the heat distribution is calculated with Equation (3.18).

$$\dot{E}_y^+ = \dot{Q}^+ \left(1 - \frac{T_a}{\hat{T}_{ln fluid}}\right) \quad (3.18)$$

With $\hat{T}_{ln fluid} = \frac{T_{out} - T_{in}}{\ln\left(\frac{T_{in}}{T_{out}}\right)}$ in Kelvin.

The subsystem boundaries from Figure 3- 3 can each have their exergy efficiency calculated with Equation (3.19).

$$\eta_i = \frac{\sum \dot{E}_{qi}^-}{\sum \dot{E}_{yi}^+} \quad (3.19)$$

After calculating individual exergy efficiencies for subsystem 1 to 4, identified in Figure 3- 3, the overall exergy efficiency can be calculated with Equation (3.20).

$$\eta = \eta_1 * \eta_2 * \eta_3 * \eta_4 \quad (3.20)$$

4 THE RESEARCH UNDERTAKEN

Following the methodology described in Chapter 3, four case studies of DE and DH systems were analysed and their operational performance assessed. This included investigating the management and performance of energy plants, the heat losses to the soil from DH networks and the exergy breakdown from the DH network to the end-users. As discussed in Section 1.3, a DH energy plant generates electricity and/or heat while consuming a primary fuel or electricity, but parasitic electricity and additional electricity are also consumed to operate the supply units and to pump the heat to the consumers. Hence, the following four investigations were assessed:

- The supply units dynamic and seasonal performance
- The thermal storage use and operating efficiencies
- The parasitic electricity consumption to operate the supply units
- The additional electricity consumption to pump the DH network flow

These investigations assisted undertaking CO₂ emissions analysis, financial assessment and the exergy efficiency study. Finally, using these investigations, an optimisation method was developed to devise the guidelines to optimise a DH system. This paper is given in Appendix E and Table 4- 1 outlines the investigations undertaken on each case study.

Table 4- 1 Research undertaken

	Elmswell DH	Strand Palace Hotel	Loughborough University DH	Pimlico DH Undertaking
Resource use and energy production	√	√	√	√
Performance of DH components	√		√	√
Component 1	Thermal storage			√
	Supply units performance	√		√
	Parasitic electricity	√		√
Component 2	Pumping DH network electricity	√		√
	DH network heat losses	√	√	√
Component 3	Substation and heat demand	√	√	√
Component 4	Night set-backs			√
	Load shifting			√
Performance metrics	√	√	√	√
	Financial analysis		√	√
	CO ₂ analysis	√	√	√
Alternative operation			√	√
Decarbonisation of the grid				√
Optimisation and exergy analysis				√

4.1 ELMSWELL DH

This study was published (Appendix A1) and presented at the 2011 “Sustainability in energy and buildings” international conference in Marseille, France. As indicated previously in Table 4- 1, the seasonal efficiency of the DH network, the natural gas to heat conversion efficiency and the total electricity consumption to pump the DH flow and to operate the EC were calculated on a monthly basis. Finally, the CO₂ emissions were also calculated and compared to the baseline.

4.1.1 DEVELOPMENT DESCRIPTION

The Elmswell Affordable Housing site located in Suffolk consists of 26 individual dwellings (13-two bed, 9-three bed and 4-one bed dwellings). The project designed by Buro Happold engineers was intended to be an exemplar of sustainable development and the project won a Housing Design Award in October 2007. The site is equipped with a community energy system powered by a main biomass boiler operating in priority. This DH system provides heating and hot water for the dwellings. Hot water is provided by instantaneous water heaters in the dwellings ensuring a sufficient supply of hot water all year round. Radiators are used as the heat emitters and are controlled using a timer and a zoned thermostatic control. This ensures the heating system to be used efficiently with little waste; Figure 4- 1 shows the construction and building type of this residential development.



Figure 4- 1 Elmswell - Energy efficient residential development (Buro Happold, 2009)

4.1.2 DESCRIPTION OF THE DISTRICT HEATING SYSTEM OPERATION

Figure 4- 2 shows a plan of this development identifying the energy plant and the consumers. In 2010, the energy plant generated 240 MWh of heat with a 200 kW biomass boiler and a 200 kW natural gas boiler. The natural gas boiler serves to supply peak heating load and to be used as back-up. Both boilers are set to modulate and to Start/Stop with the heating demand because no thermal storage is installed.

In the first instance, the natural gas and the biomass boilers' heat generation were monitored. Natural gas consumption was monitored but not the biomass usage. Measurements were collected from on-site meters on a monthly basis throughout 2009-2010. To enable performance metric analyses, it was assumed that the biomass boiler operated with an 85% seasonal efficiency. Secondly, as the consumers are indirectly connected to the DH network and are fitted with an individual heat meter, the monitoring of their heat consumption was

enabled. Finally, the total electricity consumption by the energy plant was also monitored and this included the parasitic electricity required to activate both boilers and the additional electricity to pump the DH flow.

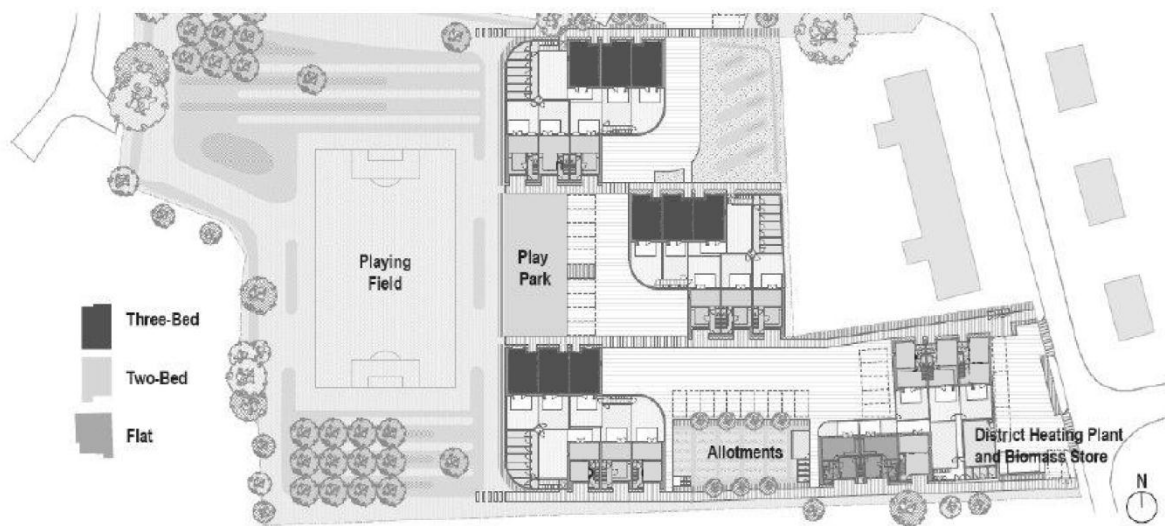

Figure 4- 2 Elmswell's dwelling types and grouping (Buro Happold, 2009)

4.1.3 PARASITIC AND PUMPING ELECTRICITY CONSUMPTION

In 2010, the combined annual parasitic and pumping electricity consumption to activate both boilers and to pump 240 MWh of heat through the DH network was monitored and found to be 36 MWh. To calculate the distribution of electricity consumption between both consumption types, a correlation value (calculated in Section 4.4.5) was used to calculate the parasitic electricity consumption, which was calculated to be approximately 2 MWh (The total fuel intake was of 321 MWh and 0.5% of this values equals approximately 2). The electricity consumption to pump the DH flow was then calculated by subtracting the calculated parasitic electricity from the total electricity consumption which results in 34

MWhe or 14% of the annual heat supplied to the DH network. Although the pumps are variable speed, this high electricity consumption is because these centrifugal pumps operate continuously at maximum velocity. Hence, the maximum difference of pressure of the pumps in the energy centre occurs when the DH network does not demand for any heat and reduces with an increasing heat demand as more flow is required to be pumped.

The operation of this DH network could be improved by controlling the speed of the pumps based on maintaining the minimum difference of pressure required by the last consumer connected to the DH network. Operating as such, the pumps would then operate as intended and at variable speed.

4.1.4 DH NETWORK LOSSES

The heating loss to the soil was calculated by monitoring the monthly heat supplied to the DH network and heat consumed by the 26 consumers in 2010. Elmswell DH supplies heat using a 75 mm diameter primary pipe with flow and return temperature of approximately 90°C and 70°C respectively. Figure 4- 3 compares the winter, summer and annual heat lost to the soil and consumed and shows that the annual heat loss to the soil was approximately 39% compared to the supplied heat.

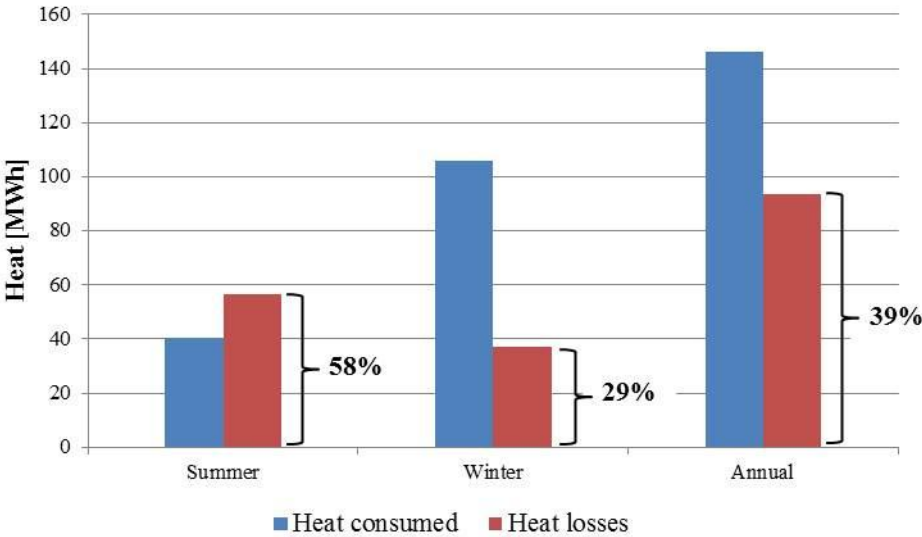

Figure 4- 3 The site's seasonal DHW + SH consumption, from 1-4-2009 to 9-4-2010 (30-10-2009 half way through and switching from summer to winter heating load)

As shown, although the heat demand reduces in the summer, the heat loss to the soil increases. The reasons for this could be explained because the consumers are each fitted with instantaneous heat exchangers and when no or little DHW is being consumed in summer, the return DH flow increases in temperature and the heat losses from the return DH network pipes increases. However, this is likely to also be because of the error from the heat meters fitted on every consumer's heat interface unit. Appendix A2 discusses this in more details.

4.2 LOUGHBOROUGH UNIVERSITY DH

The heat losses to the soil from the DH network at Loughborough University were calculated. This required monitoring of the heat supplied to the DH network and that consumed by each connected building.

4.2.1 DEVELOPMENT DESCRIPTION

Loughborough University has approximately 18,500 students, 24 academic department and over 30 research institutes. In 2011, Loughborough University won the Green Gown Award for the category “Promoting Positive Behaviour” for its sustainability awareness campaign to drive sustainability across the campus. To reduce CO₂ emissions, the University has three operating gas fired CHP engines. A 500 kWe CHP engine was installed in 2007 at the Pilkington Library, a 1 MWe CHP engine was installed in 2008 at Holywell Park and finally a 1.6 MWe CHP engine was installed in August 2011 to supply heat to the University’s DH system, which operates three DH networks: Central Park, Village Park and East Park.



Figure 4- 4 Loughborough University campus (Lboro, 2013)

4.2.2 SYSTEM OPERATION

Loughborough University DH energy plant and linked consumers are indirectly connected and benefit from AMR so their accumulated heat consumption was monitored and stored on an hourly basis. Until August 2011, the DH energy plant generated its heat with four 3 MW natural gas boilers. As this plant is not equipped with a thermal storage system, the four boilers are set to modulate and to start/stop based on the heat demand. In 2010, the total heat generated and pumped to the three DH networks was 16,719 MWh. This heat was supplied at approximately 93°C and returned at approximately 70°C. The three DH network pipes start and return from the energy plant each with an internal diameter of 150 mm.

4.2.3 DH NETWORK LOSSES

The heat consumed by the buildings connected to the DH network was 12,973 MWh in 2010. The heat lost between the generation and the consumption could be calculated and was found to be equal to 3,746 MWh or 22% of the generated heat.

4.2.4 ALTERNATIVE OPERATION

In 2011 Loughborough University DH was on the verge of installing a 1.6 MWe CHP engine without a thermal store, so an analysis was undertaken to show the benefit from the use of thermal storage. Both scenarios were simulated using EnergyPro and were also compared to two Scenarios operating a 2.0 MWe CHP engine with and without thermal storage. In the

scenario which included a thermal store, the respective thermal stores were sized with capacity equivalent to five hours of CHP engine heating load to aim to operate the CHP engines to operate throughout the year full load. Hence, 8.5 and 10.5 MWh heat storages were sized to operate with the 1.6 and the 2.0 MWe CHP engines respectively.

It can be seen from Table 4- 2, that the thermal storage and a larger CHP engine are both predicted to increase the CO₂ emission reductions. As the energy required for pumping the heat to the consumers remains unchanged in all scenarios, the energy plant CO₂ reduction was calculated; the calculation neglected the thermal store heat losses and the parasitic electricity consumption.

Table 4- 2 Scenario comparison for Loughborough University DH system

	1.6MWe, no thermal storage	1.6MWe, 8.5MWh thermal storage	2.0MWe, no thermal storage	2.0MWe, 10.5MWh thermal storage
Heating load percentage from the CHP engines	38.9%	46.9%	44.6%	54.8%
CO₂ reduction	8.8%	10.6%	10.1%	12.4%

4.3 STRAND PALACE HOTEL

The operation of Strand Palace hotel energy plant was reviewed and this study was published and presented at the 2012 International conference on innovation in architecture, engineering and construction in São Paulo, Brazil. The hotel's energy plant was assessed by analysing the monthly heat and electricity generation of every supply unit throughout 2010. The outcome from this analysis was to analyse the operation of the energy plant and a detailed financial analysis is given in Section 4.6.1.

4.3.1 BUILDING DESCRIPTION

Located in central London, this hotel was built in 1909 with a steel structure and is of 31,000 m² area. It has 785 guest rooms and accommodated 317,000 guests in 2010. At present there is no air conditioning in the guest rooms of the hotel, but it is available in 'public' spaces. The hotel was awarded "Silver" under the Green Tourism for London scheme in 2010 and was aiming to achieve "Gold" for 2011.



Figure 4- 5 Strand Palace hotel in central London

4.3.2 ENERGY PLANT OPERATION

The energy plant is located in the basement of the hotel and includes two 250 kW CHP engines and three 500 kW boilers. The CHP engines are set to modulate on the hotel's electricity demand and to operate 24 hours per day throughout the year. As heat and electricity meters were added on the generation of each supply unit, monthly readings were undertaken throughout 2010 to monitor heat generation and to assess the heat distribution. Figure 4- 6 gives the monthly heat generated by each supply unit and shows that the CHP engines never generate their potential maximum combined monthly heating load, which is approximately 450 MWh and they do not operate in summer to avoid dumping heat into the atmosphere. This happens because the plant does not benefit from a thermal store and the heating flow return temperature increases intermittently over 70°C with effect of tripping out the operating CHP engine because of too high jacket temperature. The natural gas consumption was calculated based on the high heating value (HHV) of the natural gas and

assuming the boilers and the CHP engines to operate with 85% and 78% efficiency respectively.

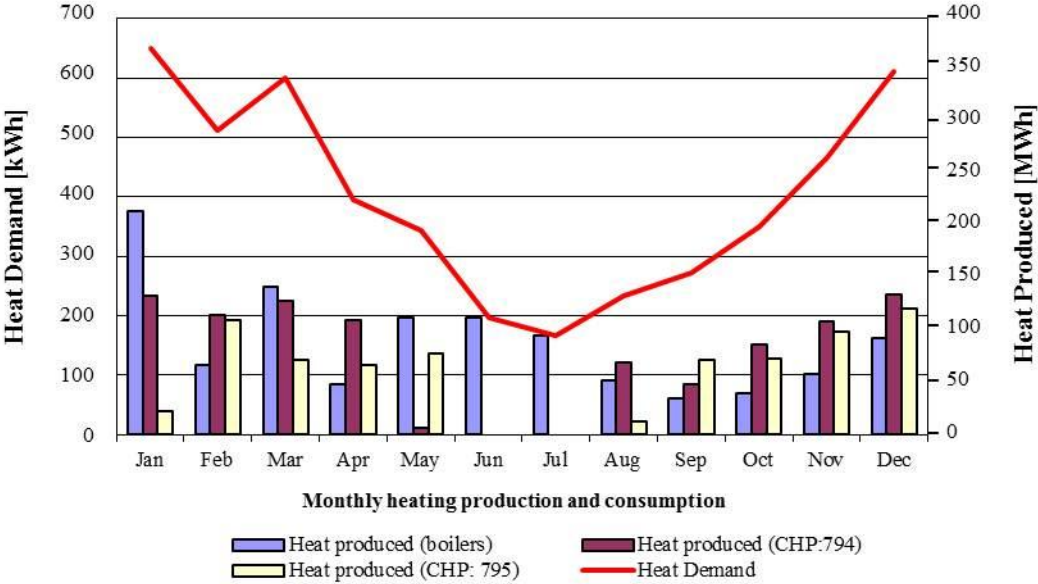

Figure 4- 6 Strand Palace Hotel monthly heat production and consumption

4.4 PIMLICO DISTRICT HEATING UNDERTAKING

A detailed account and literature review for this study can be found in Appendix C – Section 1 and Table 4- 1 refers to the research undertaken at PDHU. Seasonal and transient performance analyses were undertaken on the four components of the DH system to assess its operational performance. Alternative operation of the plant were then assessed by simulating operation with larger CHP engines, with an open-loop heat pump and finally by applying load shifting to consumers and assessing the effect of their current night set-back strategy.

4.4.1 DEVELOPMENT DESCRIPTION

PDHU supplies approximately 50,000 MWh of heat per year through 7,866 meters of DH network to 3,256 residential and 55 commercial units. A 2,500 m³ thermal store was installed in 1950 to store waste heat until 1983 from the now disused Battersea power station built on the other side of River Thames. Figure 4- 7 shows the thermal store in the centre of Churchill Gardens, a zone of PDHU DH system. Churchill Gardens is today still fitted with its 60 year old pipes running in ducts under the ground (Figure 4- 8). As shown on Figure 4- 9, the EC supplies heat to nine different legs and each starts and returns to the EC with an internal diameter of 150 mm. Five of the legs are divided from a header in the EC to supply heat to the five zones of Churchill Gardens that demands approximately 60% of the total annual heating load.



Figure 4- 7 Pimlico District Heating Undertaking

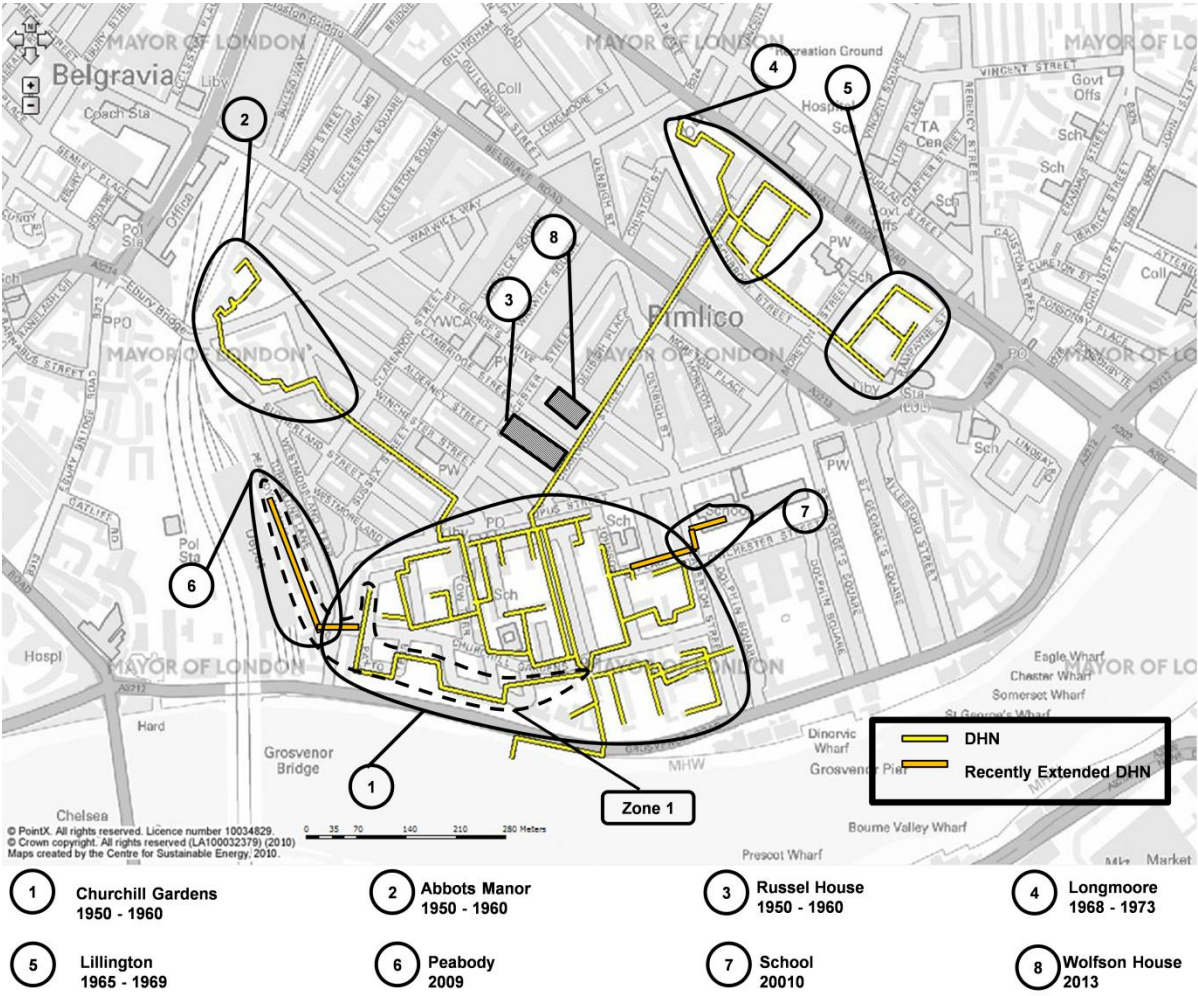

Figure 4- 8 Pimlico district heating network

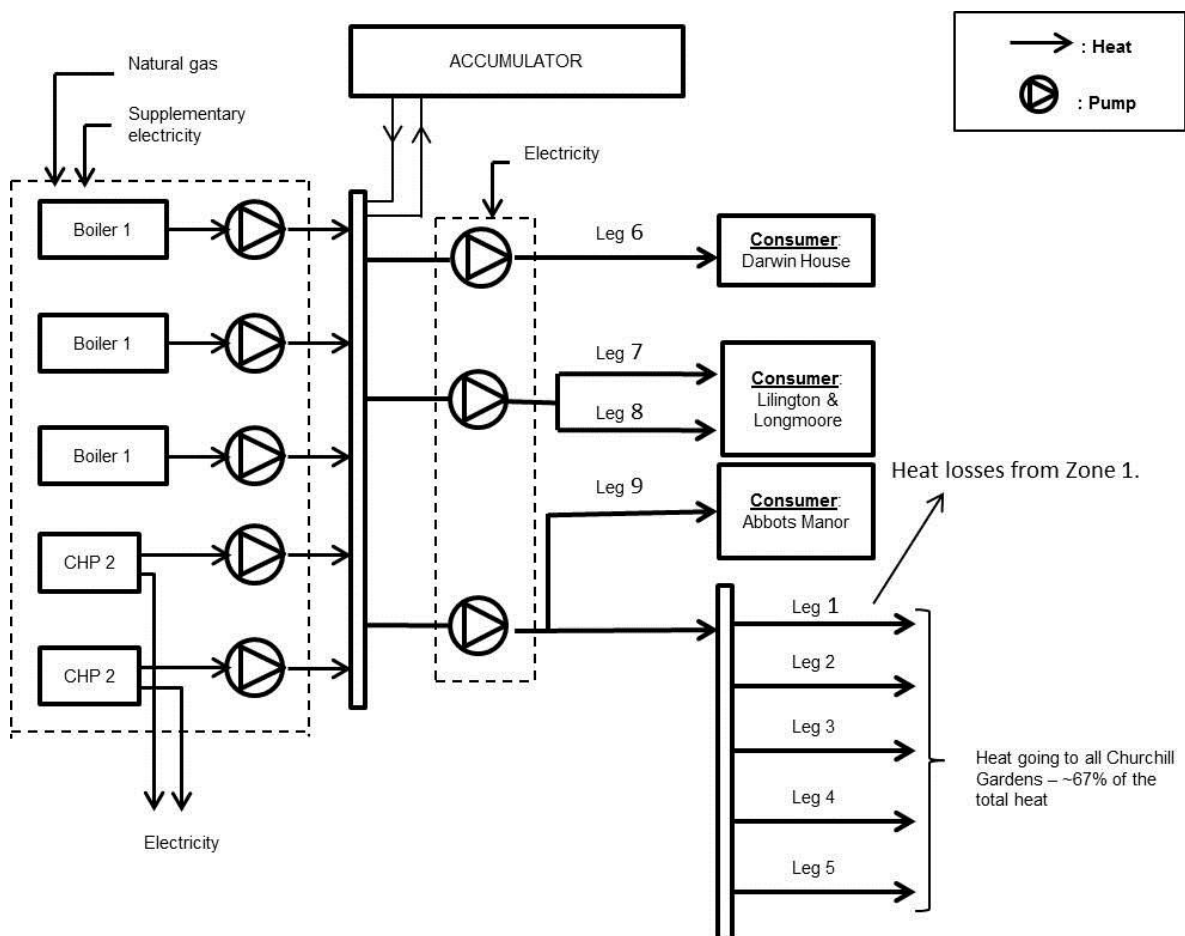

Figure 4- 9 Schematic of PDHU district heating system and its nine legs

4.4.2 SYSTEM OPERATION

PDHU is equipped with two natural gas fired 1.6 MWe CHP engines and three 8 MWth boilers. These supply units are set to generate heat at approximately 90°C and the supply temperature to the DH network varies from 75°C to 90°C depending on the heating load. The average return temperature was measured to be of 61.5°C.

The control board manages the operation of the energy plant and sets the CHP engines to operate full load during the day tariff for electricity. AMR was in use and the energy consumption and generation from every supply unit was recorded on a half-hourly interval basis throughout 2012. This enabled calculation of the daily heat generation for each supply unit. Figure 4- 10 shows the supply unit daily heat generation throughout the year and shows that the total 3.2 MWe CHP engines were sized to generate the equivalent of the summer heating load instead of being sized to minimise the operational cost as discussed in Appendix C. Since April 2012, both CHP engines generated approximately 25 MWh of heat per day and the CHP engines are set to operate full load during the day electricity tariff of 17 hours per day. From Figure 4- 10, it can be noticed that the CHP engines were not operating at the beginning of the year, this was due to PDHU operators not having agreed a maintenance contract so the CHP engines were continuously offline. Figure 4- 11 gives the duration curves that show that the CHP engines operated for less than 4,000 hours during that year and that the boilers were set to modulate, opposed to operating at full load. When the CHP engines are sized to generate the DHW heating load, they should be expected to operate approximately 5,800 hours per year.

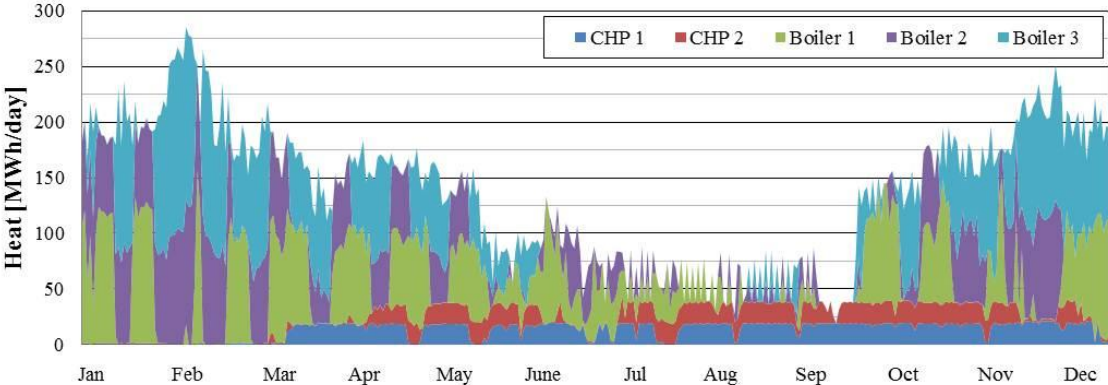

Figure 4- 10 Annual daily heat generation by supply unit

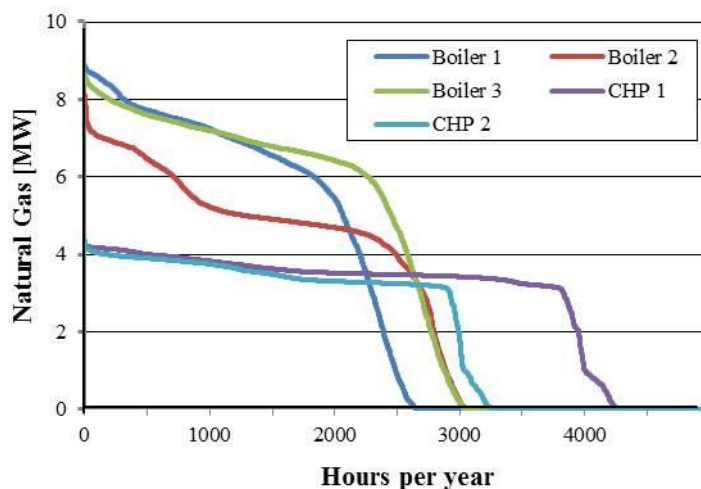

Figure 4- 11 Natural gas consumption duration curve for each supply unit

4.4.3 THERMAL STORAGE OPERATION

The main benefit of a thermal store is to decouple the heat generation from the heat demand. This enables the use of larger CHP systems, to operate the supply units full load or at maximum operating efficiency and finally to reduce the number of switch on and off cycles. Hence, a thermal store allows the supply units to generate heat and/or electricity in near steady-state condition, thus to operate more efficiently. With a difference in temperature of 30°C when charged, the thermal store has a storage capacity of 87 MWh. However, as shown in Figure 4- 12, PDHU uses approximately 30 MWh of its available storage capacity, less than half of its total thermal capacity. Based on the data analysed, the Figure also shows that the thermal store is used in charging mode two times per day in winter and every other day in summer. Hence, the thermal store at PDHU is underused and is set to charge and discharge its heat when reaching the stored heat level of ~20 and ~50 MWh respectively. This means, the

heat storage is used at 35% of its full usability with no ambition to enable greater CHP capacity or to operate the supply units more efficiently. Finally, as the stored and discharged heats were monitored on a half hourly basis, it was calculated that the thermal store operated with a seasonal thermal efficiency of 93.3% in 2012.

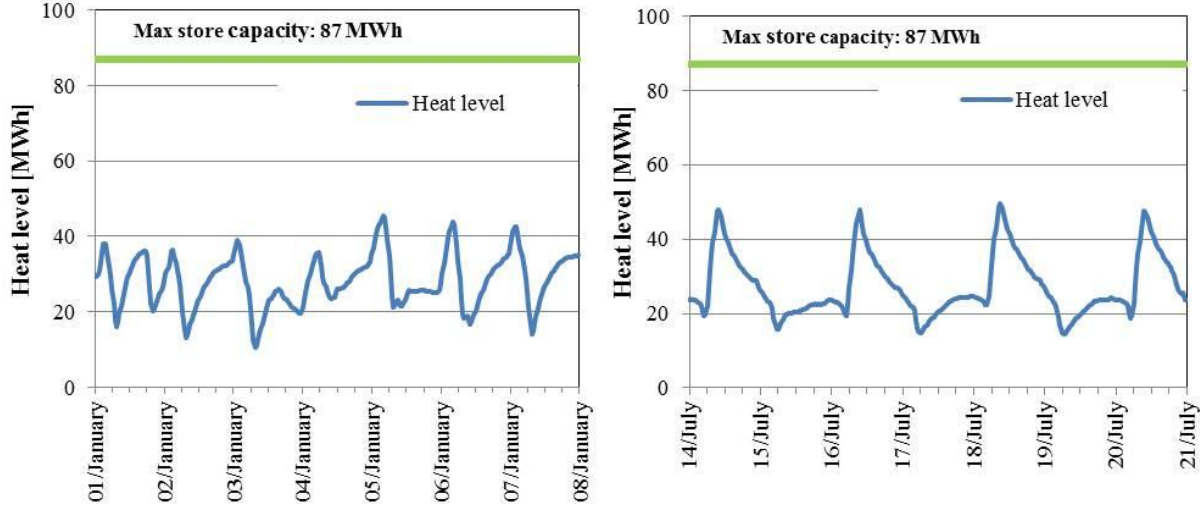

Figure 4- 12 Thermal store dynamic heat level for a typical winter and summer week

4.4.4 SUPPLY UNIT PERFORMANCE

The performance of the supply units was investigated by monitoring their consumed natural gas and electricity and/or heat generation. The outcome from this investigation was to assess and determine their performance when operating at full load or part load, in steady-state operation and during on and off cycling.

Boilers

Figure 4- 13 gives part load and full load efficiency data for the three operating boilers. The calculated operating efficiencies decrease at reduced load and equal approximately 91% when operating at full load based on the HHV of the natural gas.

With the use of the boiler duration curve given in Figure 4- 11 and the boiler efficiencies from Figure 4- 13, it was calculated that the combined average seasonal efficiency of the boilers was 87%. However, with the monitored data, it was calculated that the combined average seasonal efficiency was 84.3%. This lower seasonal efficiency could be explained if the heat meters under meter the heat when operating part load, but it is more likely because of the boilers' Start/Stop operation that circulates fresh air through it as a purging action against carbon monoxide. This has the effect of cooling the boilers before every Start and after every Stop operation.

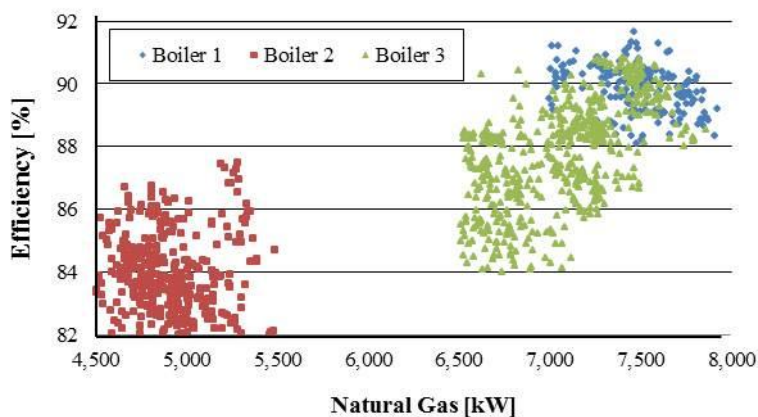

Figure 4- 13 Efficiency of boilers over their modulation range

CHP engines

The filtered monitored data used to calculate the efficiencies of both CHP engines and reported on the left chart of Figure 4- 14 show that the CHP engines operate with a near constant electrical efficiency when modulating. However, their thermal efficiency increases with decreasing load. These operating efficiencies of this CHP engine was then compared on the right chart of Figure 4- 14 to the E230 natural gas CHP engine from Ener-G (Ener-G, 2014). It can be noticed that a CHP engine operating in optimum condition, the electrical efficiency increases with an increasing load but that the thermal efficiency also reduces. However, the overall efficiency increases. Although the overall efficiency of PDHU CHP engines reduces when operating at full load, the exergy efficiency of the energy plant increases when operating the CHP engines full load and for longer hours by generating heat and electricity efficiently.

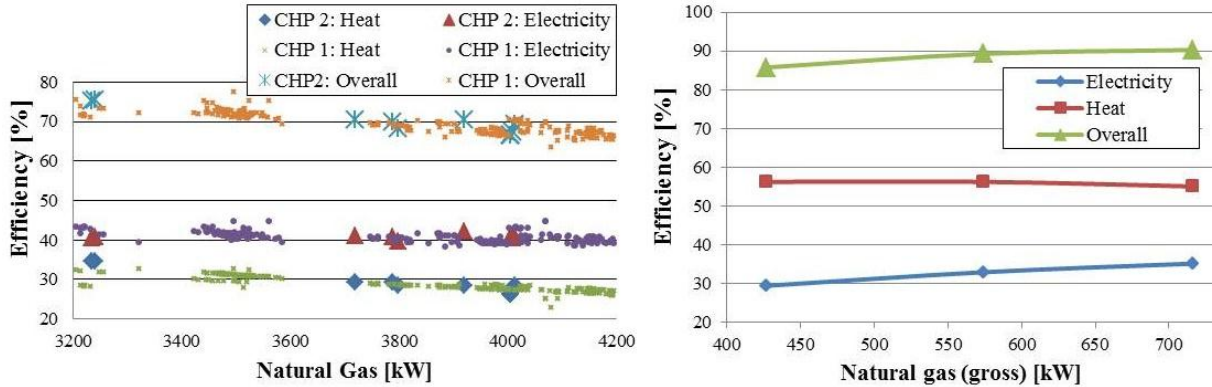

Figure 4- 14 Efficiency of CHP engines over their modulation range at PDHU (on the left) and from Ener-G technical datasheet of the E230 (on the right).

4.4.5 PARASITIC ELECTRICITY CONSUMPTION

To generate heat and/or electricity, boilers or heat engines consume parasitic electricity to enable combustion and to “cool” the unit. Thus, this parasitic electricity is consumed to firstly manage the right distribution of fuel and oxidant for combustion and secondly to circulate a flow through it to capture the generated heat.

In both technologies, the cold source is the return DH flow, but unlike the boilers, CHP engines exchange their heat with the use of an external flat plate heat exchanger. Hence, CHP engines require an additional pump to pump their cooling water through a closed loop linking the CHP engine to the external flat plate heat exchanger

As the boilers were set to modulate, the parasitic electricity consumption was monitored when operating at different loads. On the left chart in Figure 4- 15, an interpolation curve gives this consumption. As the CHP engines were set to operate at constant load since April 2012, their respective parasitic electricity consumption was monitored and is given in the right chart in Figure 4- 15. Although this parasitic electricity consumption is dependent on the operating supply units and their operational mode, it is a relatively small consumption compared to the fuel intake for both type of supply unit. To undertake performance metric analysis, Equation (4. 1) is used to calculate this electricity consumption relative to the fuel intake at PDHU. This correlation value equals 0.42% and can be considered small compared to the DH network pumping electricity consumption. Thus, to calculate the repartition between the parasitic electricity and the electricity required for pumping the DH flow when the total electricity consumption is monitored, it can be assumed that the parasitic consumption equals typically approximately 0.5% of the fuel intake.

$$Value = \frac{\text{Supplementary electricity}}{\text{Fuel intake}} = \frac{314}{74,440} = 0.42\% \quad (4.1)$$

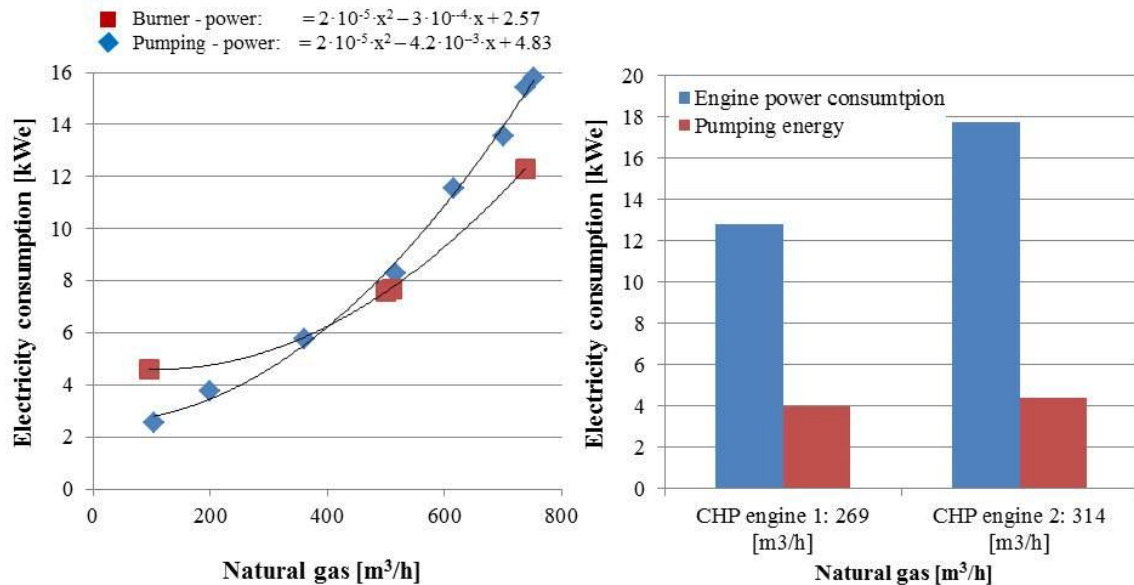

Figure 4- 15 Boilers (left chart) and CHP engines (right chart) parasitic electricity consumption for the combustion process and pumping the cooling flow.

4.4.6 ELECTRICITY REQUIRED FOR PUMPING THE DH FLOW

The annual electricity consumed to pump 50,000 MWh of heat was calculated using the half-hourly heat supplied to the DH network data throughout 2012 and the polynomial equation from Figure 4- 16. These polynomial equations calculate the corresponding additional electrical power consumption required to pump the heat rate supplied to the network. By assuming these pumps operate at constant load throughout every 30 minute interval and by aggregating these electrical consumptions, the annual electricity consumption for pumping the DH network was calculated to be 513 MWh. This equals 1% of the annual heat supplied.

This calculation is explained in more detail in Appendix C and is discussed later in Section 4.5.3 – Section 3.3.

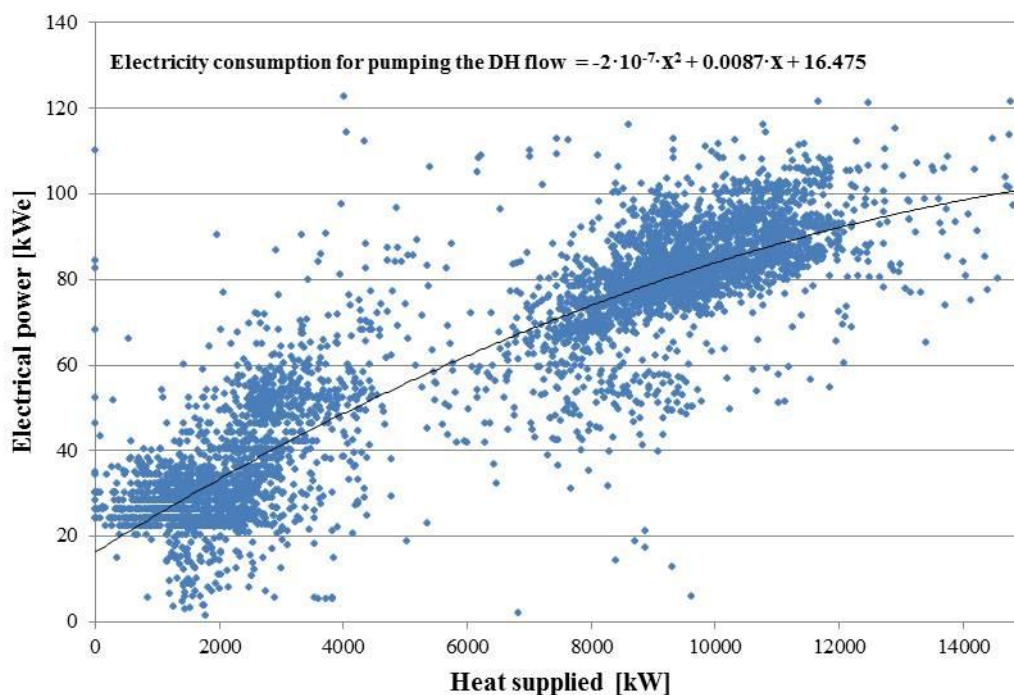

Figure 4- 16 Electrical power to pump a known amount of heat at PDHU

4.4.7 DH NETWORK LOSSES

The daily heat loss to the soil from Zone 1, a 552 meter long leg shown in Figure 4- 8, was calculated by subtracting the heat supplied to each consumer from the heat distributed from the EC. The consumed heat was monitored by AMR at half hourly intervals throughout the day and the supplied heat was calculated at 5-minute intervals with Equation (4. 2). As showed on Figure 4- 17, a typical winter day was selected (the 29th of November 2012) and PDHU supplied 26,935 kWh of heat to this leg with 26,532 kWh consumed by the users. Hence, 403 kWh of heat was lost to the soil.

$$\dot{E} = \dot{m} * C_p * \Delta T \tag{4.2}$$

As the nine legs of PDHU DH network leave the EC with an internal pipe diameter of 150 mm and all supply heat at a similar temperature, it was assumed that the total heat loss to the soil from the DH network is proportional to the heat loss to the soil from leg 1. As the total length of the DH network is 7,886 m, the total heat loss was estimated to be 5,757 kWh. Finally, as at the depth of 5 meters below the soil where the DH network is located the ground temperature is broadly constant all year round, the DH network heating loss was assumed to be constant throughout the year. Thus, the annual heat loss to the soil was calculated to be 2,101 MWh per year, which is 4% of the heat supplied in 2012. However, it must be noted that most DH network are located at a lower depth than 5 meters and the soil varies in temperature throughout the year.

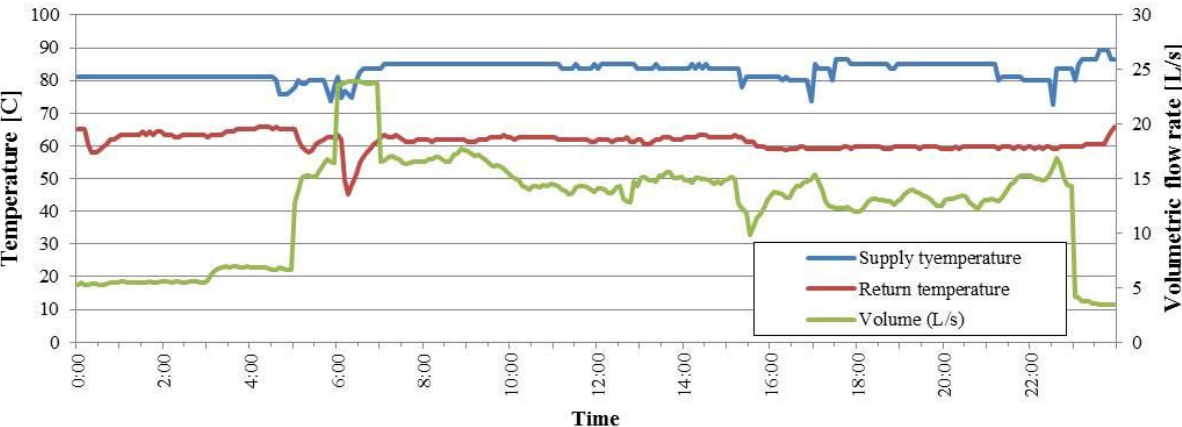

Figure 4- 17 Zone 1 measured supply and return temperature and volumetric flow rate (29-11-2012)

4.4.8 SUBSTATION AND CONSUMERS

In 1950 and when this DH network was built, direct connection to a DH network was the most employed methodology to connect consumers to a DH network. Thus, most consumers at PDHU are directly connected to the network. However, to reduce the SH temperature distribution from the convective radiators in the connected buildings, a bypass between the consumers' return and supply SH service pipe is fitted.

In summer, the DHW is the only heating load and the cooled DH flow returns at approximately 63°C during the day when the calorifiers are heated to approximately 55°C. As shown in Figure 4- 18, a cross flow flat plate heat exchanger combined with a local thermal store could benefit PDHU by reducing the return DH flow temperature to approximately 25°C and enabling a lower DH supply flow temperature than the current average temperature of 83°C.

The DH minimum supply flow temperature is set to meet the heating load. However, as some buildings in Churchill Gardens have undersized convective radiators, the minimum supply flow temperature is also set to guarantee an adequate level of heat transfer from these undersized radiators. Hence, adding larger heat convectors would help to heat the buildings with a lower heating flow temperature and would simultaneously reduce this exergy breakdown required to heat a building to 21°C.



Figure 4- 18 Cross flow heat exchanger for $\dot{m}_1 = \dot{m}_2$ and with inlet temperatures of 65°C and 15 °C.

4.4.9 ALTERNATIVE OPERATION

The current operation of PDHU was discussed in Section 4.4.2 and is compared to two operating scenarios. The first scenario investigates the operation of PDHU by increasing the plant CHP engine capacity and by simultaneously setting the boilers to operate at full load for a minimum of four hours to limit the on and off cycling. The second scenario assumes the energy plant to generate 100% of heat by the use of a heat pump which is currently considered as a renewable technology by the UK government; this would guarantee complying with current foreseen Climate Change policies. The assessed RE technology to generate this heat was a two-stage turbo-compressor heat pump.

4.4.9.1 Scenario 1: Operation with Larger CHP Engines

As the current CHP engines are undersized, additional CHP engine capacity was reviewed. This additional CHP engine capacity was sized to minimise the heating cost, see Appendix C. However, the viability of a CHP engine is directly influenced by the cost ratio between electricity and natural gas. Because this ratio reduces considerably at night, it is not viable to operate CHP engines during these periods. For this reason, to minimise the lifecycle cost of heat generation, CHP engines operate for a maximum of 17 hours per day or approximately 5,000 hours per year including two days of maintenance per month. Hence, it is good practice to assess the optimum size of a CHP engine with Equation (4. 3), where the value “factor” in the equation defines the percentage of heat to be generated by the CHP engines. PDHU has

got an 87 MWh thermal store that enables it to generate in a cost effective way approximately 80% of the annual heating load by the use of CHP engines. Thus, using Equation (4. 3), the total CHP engine capacity of the plant would be 8 MWth or 8 MWe assuming the CHP engines operate with similar thermal and electrical efficiencies.

$$CHP_{Size} = \frac{\text{factor} * \text{Annual heating load MWh}}{5,000 \text{ hrs}} \quad (4.3)$$

4.4.9.2 Scenario 2: Operation with an Open-Loop Heat Pump

The use of CHP engines is currently effective at contributing to reducing the national CO₂ emissions. However, its operating reduction in CO₂ emissions contribution is dependent of the carbon intensity factor of national grid and in some countries, such as Switzerland currently generating electricity from renewable and nuclear sources disregards the use of CHP engines.

As PDHU is located by the River Thames, this study investigates the use of an open-loop heat pump to generate the heat at PDHU using the River Thames as the heat source. The conference paper in Appendix D discusses this and also analyses a scenario operating both systems: The heat pump and the current CHP engines.

The main findings were that the operation of the CHP engine currently reduces CO₂ emissions the most but that the operation of a heat pump will progressively reduce CO₂ emissions more with decarbonisation of grid electricity. However, combining the operation of both systems, heat pumps and CHP engines, and interacting with the national electricity generation may

benefit in firstly consuming cheap electricity when excess renewable electricity is being generated and secondly in generating electricity during peak electricity demand periods.

4.4.9.3 Night Set-Backs

Approximately 75% of the buildings at PDHU apply night set-back by switching off their heating at night. As can be appreciated from Equation (4. 2), the heat supplied from a DH system can be controlled to meet the heating demand by either increasing the DH flow rate, the supply temperature, or both simultaneously.

As the buildings' heating is either turned off at night or heated similarly to that during the day, the DH return flow temperature is similar during the day and the night (see Figure 4- 17). However, at 6:15am during the morning peak heating load the return temperature reduces to less than 50°C, this is due to the night set-back applied to 75% of the buildings. At that time, the calorifiers and the SH demand in every building are activated and the DH water transfers its heat to the calorifiers and buildings that were cooled during the night leading to the DH flow cooling to less than 50°C. As discussed by Werner (2013) and as showed with the red curve in Figure 4- 19, this predominant morning peak heat demand may negate the energy saving from switching the heating off at night. However, it can be calculated that switching the heating off at night at PDHU does reduce the final energy consumption. In addition, Figure 4- 17 shows that to supply the morning peak heating load the DH flow rate is pumped at its maximum velocity and that the energy plant generates heat at its set maximum capacity with effect of supplying heat at a reduced temperature. Thus, the DH network cannot increase the DH flow rate and the EC operates at full load. For comfort concerns, it is not advised to connect more consumers to this DH system unless the EC generates heat at higher capacity

and temperature. However, by avoiding night set-back, the morning peak load would be reduced and more consumers could be accommodated without influencing the discomfort.

4.4.9.4 Load shifting

PDHU benefits from a 2,500 m³ thermal store, hence, it is understood that there is no need to flatten the heating load to enable the CHP engines to operate for longer hours. However, flattening the heating load could potentially reduce the DH supply flow temperature with the effect of potentially improving the overall efficiency of generating heat from the EC. Technologies such as heat pumps operate more efficiently when generating heat at a reduced temperature.

As PDHU operators are considering the option of operating the plant with a heat pump, a preliminary analysis of the benefit from load shifting was investigated. Different publications assess and verify that load shifting can be obtained by using building thermal mass (Braun and Lawrence, 2004, Karlsson, 2012), by avoiding night set-back or by not charging all calorifiers at the same time. A degree of load shifting could be obtained at PDHU, to assess the potential benefit on energy saving, it was assumed that an effective 2 hour load shifting could be obtained.

Figure 4- 19 compares Zone 1 heating profile given in Figure 4- 17 to a similar profile with 2 hours load shifting. This load shifting was then applied to PDHU heating load throughout 2012. With the operation of a 10 to 15 MW heat pump, both heating loads with their respective profile were simulated. A more detailed description of this heat pump and the

different operating modes are discussed in Appendix D – Section 2.2 where the heat pump is set to operate at three different modes:

- Mode 1: It increases the return DH water from 60°C to 75°C
- Mode 2: It increases the stored heat from the store from 75°C to 90°C
- Mode 3: It increases the return DH water from 60°C to 90°C

As Mode 1 generates heat at a lower temperature, it generates the heat more efficiently. Table 4- 3 compares the percentage of heat generated by each Mode for both heating load profiles that are with and without diversity.

Table 4- 3 Heat pump operation simulation using the current and a 2 hour load shifting profile

Percentage of heat generated for each mode of the heat pump operation			
	Mode 1	Mode 2	Mode 3
Current profile [%]	46	8	46
With 2 hour load shifting [%]	48.8	7.1	44.1

It can be seen in Table 4- 3 that the percentage of heat generated by each Mode of operation is similar for both scenarios. This is because Mode 1 is set to operate at night only to supply the reduced heating load and to store heat to the thermal storage. Hence, in both scenarios, Mode 1 generated the similar heating load. However, if Mode 1 had also been set to supply some heat during the day, the percentage of heat generated by Mode 1 would have increased with the 2 hour load shifting profile. As discussed in Appendix D, although Mode 2 does not generate a high percentage of heating load, it generates every morning heat peak demands.

To assess the heat pump maximum potential electricity savings that could be obtained by load shifting, it was assumed that Mode 1 could generate the total heat load. This scenario was simulated and it was calculated that the energy plant could potentially reduce its electricity consumption by a further 4.4%.



Figure 4- 19 Similar daily heating load with and without 2 hour load shifting

4.5 RESULTS COMPARISON

4.5.1 RESOURCE USE AND ENERGY PRODUCTION

A DH system should be operated in a cost effective, resource efficient and reliable way. The operation of a DH system is set from its control board and prioritises the operation of each supply unit including setting their load and their Start/Stop operation. This prioritisation is dependent on the unit's availability, the heating load and the electricity tariffs. The primary resource energy consumed and energy generated by each supply unit in each case study was monitored or calculated assuming a seasonal efficiency of 85% for boilers and 78% for CHP engines. The results are given in Table 4- 4. The percentage of generated heat by each type of supply unit was calculated for the four energy plants and is given in Figure 4- 20.

Table 4- 4 Primary energy analysis

	Primary energy consumed		Energy generated	
	Natural gas MWh	Biomass MWh	Heat MWh	Electricity MWh
Elmswell DH	166	155*	240	0
Strand Palace Hotel	8,341*	0	4,797	1,864
Loughborough University	19,669*	0	16,719	0
PDHU	74,440	0	50,138	10,352

*Calculated assuming the boilers and/or the CHP engines to operate with an overall seasonal efficiency of 85% and 78% respectively

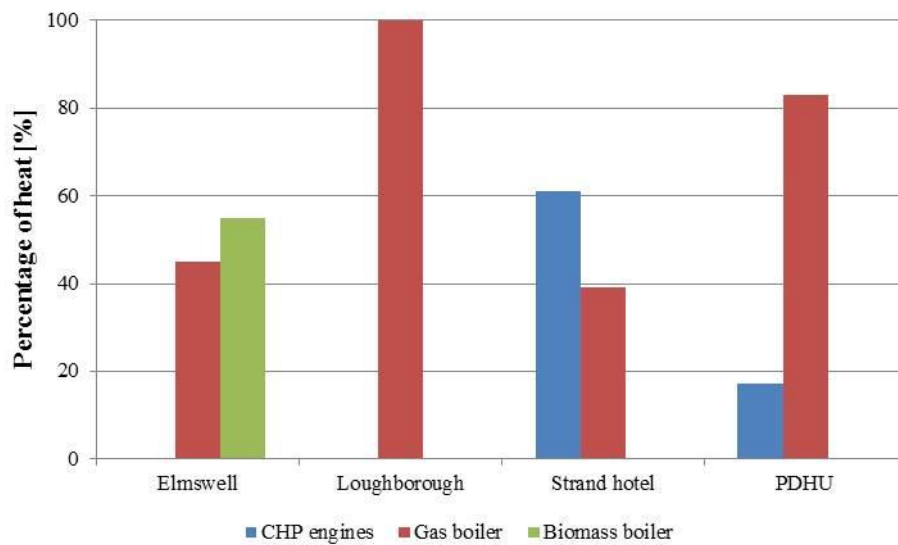

Figure 4- 20 Percentage of heat generated by each conversion system

Assuming that electricity is a more valuable energy than heat, it can be seen from Figure 4- 20 that only the Strand Palace hotel converts its primary fuel in a resource efficient way but with scope to be optimised further. To better appreciate the overall poor performances, Table 4- 5 gives the exergy efficiency for each of these plants. The electricity–exergy equals the generated electricity and the heat–exergy is calculated with Equation (3. 18). This calculation assumed that the supply units heat a flow from 60°C to 90°C at an atmospheric temperature and pressure of 5°C and 1 atm respectively. Finally, knowing the natural gas and the biomass consumed enthalpies based on the HHV, their respective consumed coenthalpy (exergy) was calculated assuming that the ratio between their coenthalpy and their HHV enthalpy is similar to methane’s ratio that is 0.9325 (Borel and Favrat, 2010).

Table 4- 5 Exergy efficiency of each plant's operation

	Exergy consumed		Exergy generated		Exergy efficiency
	Natural gas	Biomass	Heat	Electricity	
	MWh	MWh	MWh	MWh	
Elmswell DH	155	145	48	0	16
Loughborough University DH	18,341	0	3,355	0	18
Strand Palace Hotel	7,778	0	963	1,864	36
PDHU	69,413	0	10,060	10,352	29

4.5.2 DH NETWORK LOSSES

The heat losses to the soil for the three analysed DH systems were calculated and their operating thermal efficiencies are highlighted in Table 4- 6.

Table 4- 6 DH network efficiencies and heat losses

	Elmswell (2010)	Loughborough (2010)	PDHU (2010)
Heat consumed [MWh/year]	146	12,973	47,132
Heat supplied [MWh/year]	240	16,719	49,233
Heat loss to the soil [MWh/year]	94	3,746	2,102
DH network thermal efficiency [%]	61	78	95.7
Supply temperature [°C]	~87	~93	~83
Network length [m]	413	nk	7,866
Line heat density [MWh/(m·yr)]	0.35	nk	6.0
Heat loss per meter [kWh/m/yr]	0.23	nk	0.27

nk: Not known

Comparing the DH network efficiency of Elmswell to PDHU, it can be seen that PDHU is more efficient, this is principally due to its higher line heat density. As discussed further in Section 4.5.3 each leg of PDHU and Loughborough University DH supplies similar heating load per year. However, Loughborough University DH system is less efficient with 22% of generated heat lost to the soil. This can be explained because although all legs start and return with a pipe diameter of 150 mm, their average length is longer at Loughborough University. Thus, although the DH network length at Loughborough University was not measured, the line heat density is less compared to PDHU's DH network. Furthermore, the supply and return temperature of Loughborough University DH networks are set at 93°C and 70°C respectively. This is higher than at PDHU with the effect of also increasing the heat losses to the soil.

4.5.3 ELECTRICITY CONSUMPTION FOR PUMPING THE DH FLOW

Figure 4- 21 compares Elmswell and PDHU's annual electricity consumption for pumping. Elmswell DH network line heat density is 0.35 MWh/(m·yr), thus it is categorised as a DH in a low heat density area. As shown in Figure 4- 21, Elmswell DH consumes more electricity to pump a similar amount of heat to PDHU, it thus becomes more important to include this consumption for both financial and environmental assessments.

Assuming that PDHU supplies the generated heat homogenously throughout its nine 150 mm diameter supply pipes, it can be calculated that each leg supplied approximately 5,550 MWh. Assuming the total electricity for pumping is distributed proportionally to the heat load throughout the DH network, it can be calculated that each leg consumed an average of 57

MWhe of electricity to pump its heat load in 2012 as indicated in Figure 4- 21. From the data, it can also be noted that a leg at PDHU consumed nearly twice as much electricity as the leg at Elmswell DH, but supplied 23 times more heat per year. The low efficiency of pumping at Elmswell DH is quite typical for low heat density DH system. This is due to having the variable pumps operating 24 hours per day set to operate at a constant difference in pressure of approximately 1.5 bars. It would be more efficient to set the pumps to instead guarantee the minimum required difference of pressure at the most distant consumer, as showed in Figure 4- 22. This would then establish the operating flow and required difference in pressure at the EC, which would be lower than the current setting of approximately 1.5 bars to guarantee the flow throughout the DH network.

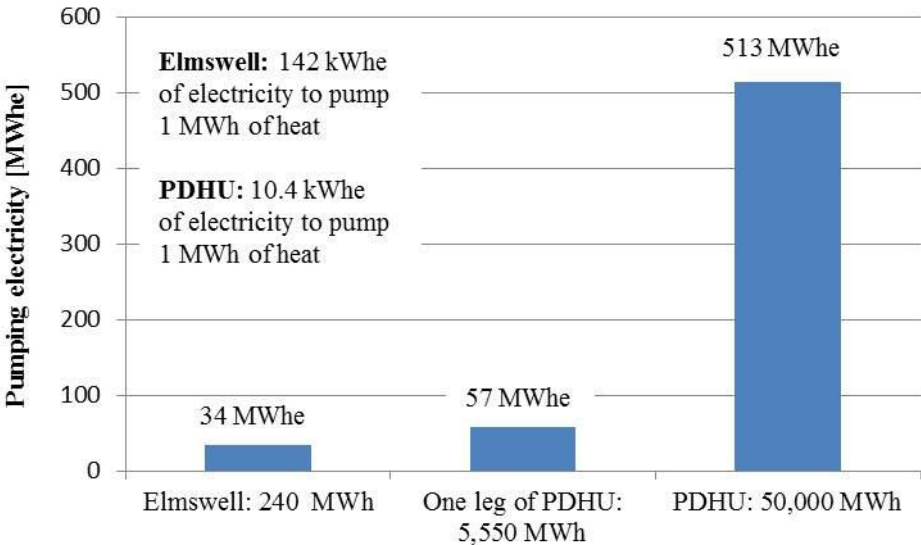

Figure 4- 21 DH network pumping electricity at Elmswell and PDHU

To enable performance metrics analyses at Loughborough University DH, DH network electricity consumption for pumping was calculated assuming that it is proportional to PDHU electricity consumption required for pumping, with respect to the total annual heat supplied. This calculated value is given in Table 4- 7. The assumption made can be justified because PDHU and Loughborough DH system are composed of nine and three legs respectively and supply a similar amount of heat of approximately 5,550 MWh/yr in each leg and that all start at the EC with an internal pipe diameter of 150 mm.

Table 4- 7 DH network electricity consumptions for pumping

	Elmswell (2010)	Loughborough (2010)	PDHU (2010)
Heat Supplied [MWh/year]	240	16,719	49,233
DH network pumping electricity [MWh/year]	34	174*	513
Electricity required to pump 1 MWh of heat [MWhe]	0.142	0.0104*	0.0104

*Calculated

However, it should be noted that the electricity consumption for pumping is also dependent on:

- The total length of the DH network
- The difference between the supply and return DH flow temperature and its flow rate
- The control of the difference in pressure (ΔP) between the supply and return pipe.
Note: At PDHU it sets the ΔP between the supply and return pipe at the EC which is less efficient than setting it between the supply pipe at the EC and the return pipe at the last connected consumer
- The operational efficiency of the pumps

Pumping power and pressurisation

The total power required to circulate the DH flow can be calculated with Equation (4. 4) (Werner, 2013). The required electrical power for pumping is proportional to the product of the pressure drop and the volume flow.

$$P_{el} = \left(\frac{\Delta P_{pump}}{\eta_{pump}} \right) \cdot \dot{V} \quad (4. 4)$$

Figure 4- 22 gives an example of pressure drop occurring through the route length of a DH network. It can be appreciated that the pressure drop is symmetrical between the supply and the return pipe. As the figure assumes that the pipe internal diameter remains the same throughout the DH network, the pressure drop on the supply pipe reduces after each linked consumer. This occurs because the pressure drop is proportional to the square of the water velocity and as the DH flow rate reduces after each consumer, the velocity also reduces. Hence, if the DH flow rate is to be doubled throughout the DH network, the pressure difference must be four times and the pumping energy eight times as great at the energy centre.

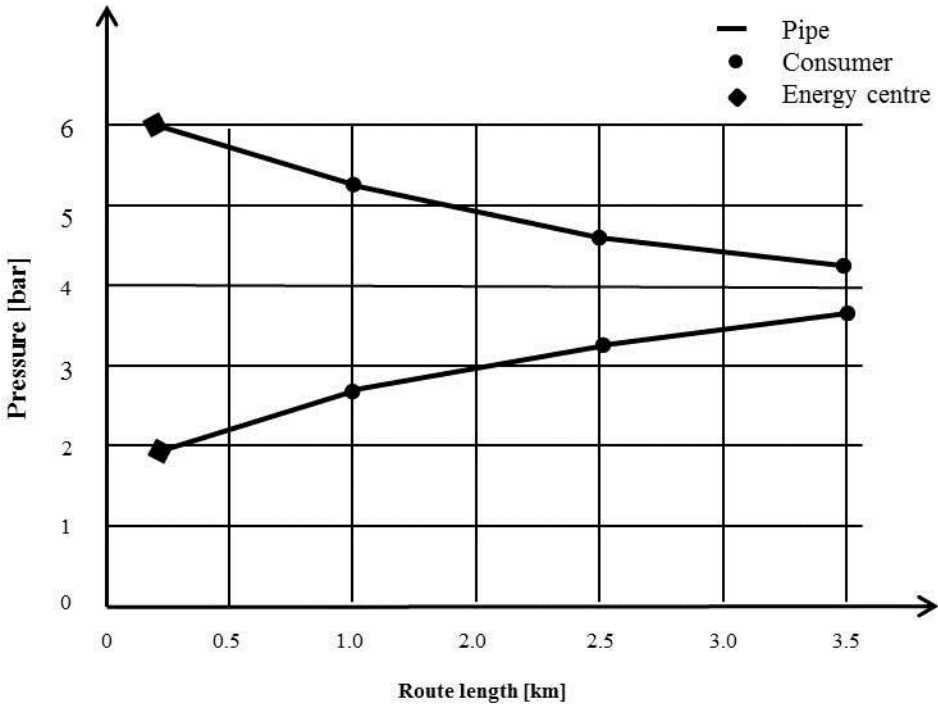

Figure 4- 22 DH network progressing pressure

4.6 PERFORMANCE METRICS COMPARISON

4.6.1 FINANCIAL ANALYSIS

As discussed in Section 3.2.5.3, the financial analysis is undertaken differently if the operator finances the new DE using on or off-balance sheet financing. A detailed financial analysis was undertaken for the Strand Palace hotel and PDHU.

Strand Palace Hotel

Strand Palace Hotel has arranged to operate their two 250 kWe CHP engines with an ESCo. Figure 4- 23 compares the hotel's current operation cost to the baseline. In winter months when the CHP engines operate close to 24 hours per day at full load, the operational cost including the ESCo monthly payment is reduced in comparison to the baseline. In the summer months, although the CHP engines do not operate, the ESCo invoices its monthly payment and therefore the operational cost increases compared to the baseline. From this figure, it can be determined that the hotel's annual cost was £ 564 higher than if it had not invested in these CHP engines. However, the ESCo make £ ~77k annual net operating income after including a calculated allowance of £ 13k for the maintenance cost of both CHP engines. As the installation cost for both CHP engines was £ 420,000, the return on investment for the ESCo was calculated to be less than 6 years.

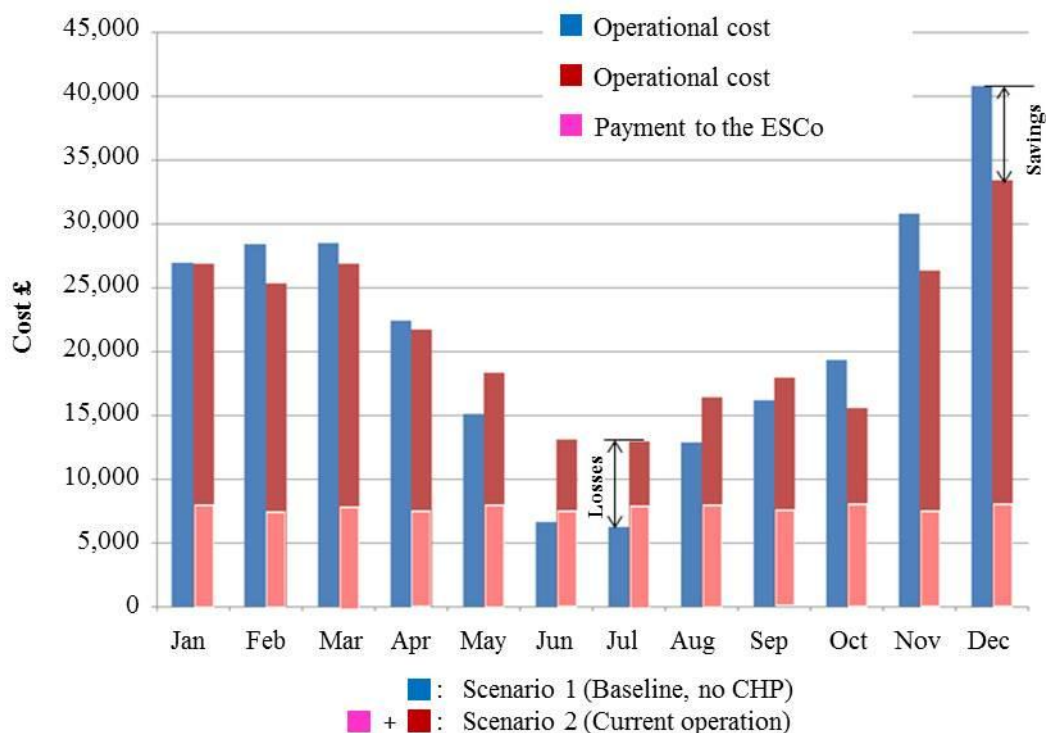

Figure 4- 23 Financial performance of the Strand Palace hotel's energy plant compared to the baseline

Pimlico district heating undertaking

The actual heating cost was calculated in 2012 and was compared to the potential heating cost if the plant was operating with larger CHP engines. The current operational cost was also compared to a second scenario that generates heat with a single open-loop heat pump and a third scenario that operates the plant by combining the operation of the heat pump and both current CHP engines.

A sensitivity analysis was undertaken and assessed the financial feasibility of PDHU investing in additional CHP engines. This sensitivity analysis firstly looked at the impact of

increasing or decreasing electricity and natural gas costs, and secondly the effect of a reducing interest rate on the loan for purchasing additional CHP engine capacity. To undertake this analysis, the financial model assumed that the additional CHP engines were purchased with a 10 year repayment loan agreement. The detail of this sensitivity analysis is given in Appendix C – Section 3.6.1.

These comparisons showed that PDHU could reduce its heating cost by installing larger CHP engine capacity or by installing an open-loop heat pump. However, for the heat pump scenario, the repayment loan contract needs to be agreed over 20 years, which differs from the typical 10 year repayment loan for purchasing CHP engines, this is due to the higher capital cost of the heat pump.

As discussed in Section 1.6, the financial analysis is in reality more dynamic. It is influenced by prevailing and future electricity and natural gas costs and it can also be positively affected by governmental incentives such as RHI if a RE technology, like a heat pump, is used. However, to benefit from the RHI, the heat pump must generate heat with a COP of at least 2.9 and the RHI tariff structure operates on a 12 months basis. This means that during that 12 month period, an initial amount of heat generated by the open-loop heat pump up to the equivalent of 1,314 hours of an installation's full load capacity will be payable at a higher tariff, which is currently 8.7 p/kWh. Any further heat generated during that 12 month period will be payable at the lower tariff which is currently 2.6 p/kWh. As set out in the DECC RHI Policy Document, the intention of different tariffs during a calendar year is to mitigate the risk of participants generating heat excessively or wastefully in order to receive higher payments (Energy Act 2008, 2014).

Assuming that PDHU operators decide to go forward with the open-loop heat pump alternative and assuming that 100% of the heat would be generated by the open-loop heat pump, PDHU could benefit by approximately £2.2 million per year from the RHI for 20 years. Thus, PDHU could potentially benefit by approximately £45 million in total compared to the installation cost of this supply unit, which is of approximately £6.6 million (Friothers, 2013).

4.6.2 CO₂ EMISSION COMPARISON

The CO₂ emissions for each case study were calculated and compared to the baseline. Table 4- 8 gives the consumed heating and electricity load, the current CO₂ emissions and the equivalent baseline CO₂ emissions.

The current CO₂ emissions of each energy plant were calculated using the following annual monitored or calculated data:

- Natural gas or biomass consumption
- DH network pumping electricity consumption
- Supply unit parasitic electricity consumption

The equivalent CO₂ emissions were calculated assuming that the consumed heat was generated by individual natural gas boilers operating with a seasonal efficiency of 85% and

that the consumed electricity was provided by the grid with the carbon intensity factor given in Section 3.2.5.2.

As PDHU CHP engines are a DE technology and that the electricity generated is consumed locally, it is assumed that no losses occur due to exporting electricity. Thus, the total generated electricity is fully consumed.

Table 4- 8 Current CO₂ emissions compared to the baseline scenario

	Elmswell (2010)	Loughborough (2010)	PDHU (2010)	Strand Palace hotel
Consumed load				
Heat [MWh/year]	146	12,973	47,132	4,797
Electricity generated[MWh/year]	0	0	10,352	1,864
Current CO₂ emissions				
Natural gas [MWh/year]	166	19,669	74,440	8,341
Biomass [MWh/year]	155			
Parasitic electricity [MWh/year]	2	98	314	42
Pumping electricity [MWh/year]	34	174	513	--
CO ₂ emissions [tonne CO ₂ /year]	61	4,390	16,508	1,824
Baseline CO₂ emissions scenario				
CO ₂ emissions [tonne CO ₂ /year]	37	3,297	17,350	2,186
CO₂ reduction [%]	-65	-33	4.9	16.6

A CO₂ emissions reduction of 17% at the Strand Palace hotel confirms the potential of DE technologies to contribute to reducing the national CO₂ emissions. However, this table also

confirms that DH systems frequently operate with poor efficiencies and when generating heat with traditional boilers, such as at Loughborough University, the CO₂ emissions are increased compared to the baseline. As the boilers were assumed to operate with similar seasonal efficiency to the baseline, the increase in CO₂ emissions was mostly due to heat losses to the soil of 22%.

PDHU, with a 2,500 m³ thermal store in a high density area would seem to be an ideal scheme to reduce CO₂ emissions from a DH system; however the reduction in CO₂ emissions is only 5%. This is because PDHU does not generate renewable energy and the operating CHP engines are undersized, see Appendix C.

Although Elmswell-DH generates 55% of its heating load with a biomass boiler, CO₂ emissions are increased by 65% compared to the baseline. This increase can be explained by the following three reasons:

- The natural gas boiler operates without the use of a thermal store and its seasonal efficiency is reduced to 65%
- The annual heat loss to the soil is 39%
- The DH flow pumping electricity consumption is not negligible and equals 14% of the heat supplied

4.7 GRID DECARBONISATION

With the current high carbon intensity of grid electricity, generating electricity from natural gas with efficiency as low as 40% contributes to reducing the current national CO₂ emissions. According to the forecasts for UK electricity consumption discussed earlier in Section 1.2.1, the total UK end-users' electricity demand could increase from the current 325 TWh to 350 TWh by 2030.

In Figure 1- 6 and Figure 1- 7 it was shown that in 2012, 17 TWh more renewable electricity was generated than in 2009. This additional renewable electricity generation contributed to increasing the total percentage of national renewable electricity generation by approximately 5%. In addition to renewable electricity generation, the UK has set out plans to deliver a total of around 16.5 GWe of new nuclear power capacity by 2030. This would require at least five new nuclear power plants with a total of at least 12 new nuclear reactors (HM Government, 2013). Hence, the possible 2030 electricity end-user demand of 350 TWh could be generated from:

- **Nuclear energy:** Assuming 16.5 GWe nuclear power plant to operate at full load throughout the year, the annual nuclear electricity generation could be of 140 TWh. This would be 40% of the total electricity demand.
- **Renewable energy:** Assuming the renewable electricity generation to increase until 2030 as it has since 2009, an additional 102 TWh would be generated by 2030, compared to 43 TWh in 2012. Hence, by 2030 a total national electricity generation of 145 TWh or approximately 41% could be provided from RE.

Hence, 81% of the national grid electricity load may be generated from low or decarbonised energy sources with the national grid electricity decarbonised by 50% before 2030. Consequently, technologies such as gas-fired CHP engines could potentially become redundant.

4.7.1 GRID DECARBONISATION APPLIED TO PDHU

As the national grid is decarbonising from its current carbon intensity factor of 0.519 kg CO₂/kWh, this section assesses the viability of two different supply units for generating the heat at PDHU in line with this decarbonisation.

As analysed in Section 4.4.2, PDHU generates heat with natural gas boilers and two 1.6 MWe CHP engines, with a reduction in CO₂ emissions of 4.8% compared to the baseline. The current level of CO₂ emissions reduction was compared to the reduction possibility for the two following Scenarios.

Scenario 1 generates heat and electricity with natural gas boilers and two CHP engines of 4.4 MWe. The CHP engines are sized to minimise the current heating cost.

Scenario 2 operates the DH system and generates heat with a single 10 to 15 MW open-loop heat pump connected to the river Thames.

Table 4- 9 gives the resource energy and electricity consumption in all scenarios to supply similar amount of heat. The electricity generated is also given.

Table 4- 9 Energy consumed from the EC and provided to the end-user

	Energy consumed from the EC		Energy provided to the end-user	
	Natural gas MWh	Electricity MWh	Heating MWh	Electricity MWh
Current operation	74,440	828	47,132	10,352
Scenario 1	117,869	1,010	47,132	41,917
Scenario 2	0	18,658	47,132	0

As shown in Table 4- 10, with the current national grid electricity factor of 0.519 kg CO₂/kWh, Scenario 1 would reduce the CO₂ emissions by 27% and Scenario 2, although operating a renewable technology, would reduce the CO₂ emissions by only 12%.

The current CO₂ emissions figure was then compared to the upcoming CO₂ emissions reduction that will be realised if the grid electricity carbon intensity factor reduces to 0.4 kg CO₂/kWh. It can be seen that the CO₂ emissions reduction savings in Scenario 1 halves from 27% to 15% but that it triples to 32% in Scenario 2. Furthermore, Scenario 2 operating with an open-loop heat pump would be expected to become carbon free with the move to decarbonised grid electricity generation.

Table 4- 10 Current and near future CO₂ emissions

	Current electricity carbon intensity factor: 0.519 kg CO ₂ /kWh			Near future electricity carbon intensity factor: 0.4 kg CO ₂ /kWh		
	Baseline CO ₂ emissions	EC CO ₂ emissions	Reduction	Baseline CO ₂ emissions	EC CO ₂ emissions	Reduction
	Tonne CO ₂	Tonne CO ₂	%	Tonne CO ₂	Tonne CO ₂	%
Current operation	16,493	15,167	8	15,245	15,070	1
Scenario 1	32,650	23,861	27	27,945	23,742	15
Scenario 2	10,979	9,646	12	10,979	7,463	32

4.8 OPTIMISATION AND EXERGY ANALYSIS

Appendix E proposes a new methodology for optimising a DH system. This document is produced for use by the practitioner and a detailed explanation for the calculations and an example with comments is also given. It optimises the system in a cost effective and resource efficient way while maximising the system's operating primary energy efficiency along with the exergy efficiency. As the exergy analysis is not sensitive to CO₂ emissions, this optimisation document assesses separately the CO₂ emissions reduction to comply with regulations. Also, this document proposes to compare alternative strategies, such as operating a different supply unit, and to compare their respective performances.

As exergy efficiencies can never exceed 100% and include parasitic energy consumptions, the exergy efficiency identifies the location, the magnitude and the causes of thermodynamic inefficiencies while looking to enhance the understanding of the energy conversion processes of a DH system. Hence, exergy analysis is a valuable tool to improve DH system performances. It is the only theory that unambiguously assesses the performance of every

component of the system from a thermodynamic viewpoint. The exergy destruction rate and exergy efficiency can then be calculated for each individual component and compared to the initial exergy consumed.

5 FINDINGS AND IMPLICATIONS

Decentralised energy combined with energy storage could assist the national power sector to reduce peak electricity demands that would otherwise most likely be met by combusting some fossil fuel. As the current share of UK renewable electricity is less than 15%, all of the generated renewable electricity is consumed. Thus, the progressive increase in renewable electricity generation capacity proportionally increases the quantity of renewable electricity generated. However, with higher installed renewable electricity generation capacity, it is probable that at times this will exceed demand resulting in shedding unless electrical storage is provided. To mitigate the need for electrical storage capacity, DH systems could be used. DH systems operating with thermal storage could be used to turn excess generated renewable electricity into heat for immediate or later use.

5.1 KEY FINDINGS OF THE RESEARCH

5.1.1 THE OPERATIONAL PERFORMANCE OF EACH COMPONENT OF A DH SYSTEM WERE ASSESSED

Although DE and DH systems generate heat to be used locally, DE differs from DH systems because it also functions as a generator of electricity. However, DE technologies can also be used in a DH system to generate electricity and heat. To supply the heat demand from a DH energy plant to the consumers, a primary fuel and some electricity is consumed while heat is lost to the soil and the atmosphere.

Energy plant: The transformation of primary energy such as fossil fuel to electricity and/or heat never reaches 100% of efficiency based on the HHV of the fuel. However, as investigated at PDHU, if a non-condensing boiler operates at full load in steady-state condition, it operates close to 100% efficiency based on the LHV of the fuel or 91% based on its HHV.

DH network: A certain amount of additional electricity is consumed to pump the heat from the EC to the connected consumers. As part of this process, some heat losses to the soil occur from the DH network. As the soil temperature at a shallow depth is usually warmer in summer, the heat losses to the soil would be expected to be lower in summer compared to winter. However, it was found that at Elmswell-DH more heat losses occur in summer, because of higher temperature circulation and because of heat meters undermetering the heat consumed by the consumers. These circulation losses happen because the instantaneous heat exchangers that are in operation are set to guarantee DHW at any time of the day and the DH return temperature increases when no DHW is being consumed.

It was also found that the electricity required for pumping is very dependent to the line heat density of the DH system. Generally, for a similar amount of pumped heat, the electricity consumption for pumping increases with a reducing line heat density. A comparison of electricity consumption for pumping was made between PDHU and Elmswell-DH which are respectively of high and low line heat density. From their respective annual heating loads, it was calculated that the electricity consumption for pumping at PDHU equalled 1% to the pumped heat, while the electricity consumption at Elmswell-DH was 14% of the pumped heat.

Substation and consumer: At PDHU, consumers' SH circuit is directly connected to the DH network and their DHW is heated by the use of calorifiers. Although this direct connection minimises the exergy breakdown from the DH network to the SH circuit, replacing the current calorifiers with cross flow flat plate heat exchangers combined with a thermal store, would also reduce the exergy breakdown by increasing the cooling of the DH flow and by reducing the electricity required for pumping and heat losses to the soil.

By applying night set-backs and switching the heating off at night, PDHU makes use of the thermal capacity of the buildings. This use of the buildings' thermal capacity differs from traditional load shifting, because load shifting aims to flatten the heating load. Currently, this night set-back strategy at PDHU reduces the SH demand and the total energy consumption of the plant. However, the DH network is required to pump heat every morning in winter at its set maximum flow rate in each leg and simultaneously generate heat at its set maximum capacity. In PDHU case study, the supply temperature is set at approximately 83°C, but reduces during the peak demand in the morning because of the applied night set-back and the DH flow returning at a reduced temperature. Hence, connecting new customers would increase the discomfort in homes by increasing the time required in the morning to re-heat the buildings to the set daytime indoor temperature. For this reason, night set-backs should be avoided when supplying heat to energy efficient buildings: The energy savings by reducing the heating load at night would not necessarily compensate the increased energy consumption to supply the morning peak heating load. Furthermore, as it is common to supply more heat by increasing the supply temperature, night set-back should also be avoided because of the effect associated with reducing the efficiencies of technologies such as heat pumps.

Although load shifting strategy is not applied at Elmswell DH, it can be concluded that applying load shifting by adding a DHW thermal store at the consumer could minimise the boilers' conversion losses and the heat losses from the return pipe of the DH network. The boilers could then operate at full load for a given time during the day.

5.1.2 OPPORTUNITIES TO REDUCE LOSSES IN EACH OPERATING

COMPONENTS OF A DH SYSTEM

Energy plant: The efficiency of the supply units at PDHU and Elmswell DH were calculated and it was found that their efficiencies could be improved by setting the boilers to operate full load or by reducing the heat pump generated temperature. As heat losses also occur from a thermal store, the store heat losses should only be permitted when utilising the thermal store with the goal of saving further energy. A stratified thermal store has a low and a high temperature within it and more heat losses occur from the higher temperature region. Hence, a thermal store should only be used to maximise the day time cogeneration or to reduce fuel conversion losses by setting supply units such as boilers to operate at their maximum efficiency.

DH network: As a DH network consumes some electricity for pumping and loses heat to the soil, a DH network optimisation consists of setting the DH flow rate and temperature level to minimise the energy cost or the CO₂ emissions while minimising the heat losses to the soil and the consumption of electricity for pumping. Assuming a set DH flow return temperature, the optimised DH flow rate and supply temperature are calculated to meet the heating load as

well as the predictive heat losses to the soil. The heat losses to the soil vary with the supply temperature and the time delay for the DH mass of water to reach every consumer.

From the substation and the consumer: The substation and the consumers have a direct influence on the energy plant performance. The consumers determine the required DH flow and return minimum temperature and can help to flatten the heating load. Minimising the supply and return reduces the heat losses to the soil. Flattening the heating load enables the energy plant to generate heat for longer periods with larger CHP systems.

5.1.3 MINIMISING THE OVERALL LOSSES OF A DH SYSTEM

As a DH system is composed of four components and as their individual efficiencies are dependent, achieving minimum overall losses does not necessarily mean reducing the losses of every component of the DH system. For instance, although heat losses occur from thermal stores, their uses enable more cogeneration and allows boilers to operate at full load with higher efficiency.

5.1.4 A DH SYSTEM OPTIMISATION METHODOLOGY WAS DEVELOPED

A DH system is considered optimised when operating in a cost effective and resource efficient way. The DH system optimisation document given in Appendix E developed a method to optimise any DH system and considers a DH system optimised when:

- The overall losses are minimised by optimisation of the primary energy efficiency
- The overall exergy efficiency is maximised
- Short and long term CO₂ emissions reduction is guaranteed

5.1.4.1 Maximisation of the exergy efficiency

The maximisation of the exergy efficiency of a DH system starts from the operation of the energy plant by firstly guaranteeing the operational availability of the most exergy efficient supply units. This is achieved by putting in place reliable maintenance agreement contracts. Secondly, to maximise the overall exergy efficiency of a cogeneration plant, the largest heating load must be generated by an exergy efficient supply unit. Thirdly, to enable further generation of heat from the most exergy efficient supply unit, a thermal store may be included to uncouple the heat generation from the demand and the supply unit may then be set to also store heat in the store for later use or to supply peak demands. Finally, to minimise the exergy conversion losses, the consumers should be directly connected to the DH network for the SH and the DHW should be generated by the use of cross-flow flat plate heat exchangers and a thermal store.

5.1.4.2 CO₂ emissions minimisation

CO₂ emissions reduction achieved by a DH system is a dynamic calculation. It depends on the defined baseline and on the national grid carbon intensity factor. According to UK

governmental plans, by 2030 80% of the electricity will be generated by low carbon resources so natural gas fired CHP engines could potentially then become redundant. Currently the natural gas fired CHP engine is the most efficient technology to reduce CO₂ emissions. However, the national grid electricity supply is decarbonising and energy plants operating currently with natural gas fired CHP engines will have to adapt to a renewable or low carbon system to remain competitive.

5.2 CONTRIBUTION TO EXISTING THEORY AND PRACTICE

Two original contributions to knowledge were achieved in this research. Both fall under the category of “*empirical work which has not been done before covering scientific measurement and/or engineering development*” (Fancis, 1992). These contributions are:

5.2.1 CONTRIBUTION 1

Operational, financial and exergy performance assessments of three DH systems and one DE technology. The reviewed literature identifies a lack of studies monitoring the performance in use of DH systems. Governments or emission trading schemes, such as the EU ETS, have information about the energy consumption from end-users and about their primary energy consumptions. However, it does not have substantial information about the operational performance of supply units and of a DH system in its entirety. This thesis assessed the performance of four different DE systems. Three of these DE systems were DH systems.

The methodology used followed three steps: Firstly, energy consumption benchmarks were obtained from this analysis. Secondly, seasonal and dynamic performance were calculated which can be of use to practitioners. Thirdly, this analysis gives advice on the operational management of the plant.

Results indicate that all analysed systems had poor operating performance primarily because the operation of the supply units had not been fully optimised. Financially this means that the operational cost could be significantly reduced.

5.2.2 CONTRIBUTION 2

A methodology to optimise a DH in a resource efficient and cost effective way was developed.

A DH system can be financially optimised while complying with Governmental CO₂ emissions target. However, DH is also about generating heat in a cost effective and resource efficient way, therefore exergy efficiency calculation was also included in the proposed optimisation methodology.

This optimisation methodology maximises the operational primary energy efficiency of every component by minimising their losses. It then maximises the overall exergy efficiency and addresses the current and forecast CO₂ emissions reduction to meet regulations.

The optimisation methodology that was developed underwent a validation exercise by applying it to a case study DH system. Results showed that a CHP engine energy plant could operate with a maximum exergy efficiency of approximately 55% if heating water from 60°C to 90°C and that the three other components of a DH system could reduce their exergy conversion losses by minimising the supply and return temperature simultaneously.

5.3 IMPLICATIONS/IMPACT ON THE SPONSOR

As consultancies such as Buro Happold are becoming more involved with DH, this thesis will add to the engineers' knowledge and inform clients more adequately relating to this system. Firstly, this thesis explains the interaction of DH consumers with the DH system. Secondly, a DH system is also a DE technology that is part of the built environment; Buro Happold engineers already assess DH systems with goals to comply with policies and to reduce heating cost and CO₂ emissions. Thus, this thesis will enable Buro Happold engineers to undertake DH work more precisely and reliably.

Although buildings are reducing energy demand, existing and most new developments have a greater line heat density than 0.2 MWh/(m*yr) and this research provides support for consultants to install a DH system as soon as the line heat density meets this value. However, this research also provides implication on how to operate a DH system as well as how to assess the operation of alternative technologies.

Finally, this research may also be of use to consultancies to enable them to become UK DH subject matter experts and therefore receive new commissions to assess, optimise and operate new or existing DH systems.

5.4 IMPLICATIONS/IMPACT ON WIDER INDUSTRY

In the UK and within the reviewed literature no analysis assessed the operational performance of a DH system with its financial cost and CO₂ emissions. Thus, this analysis will hopefully influence the wider industry by recommending the review of DH systems' operations and potentially encouraging civil servants to look into improving regulations of these systems. The final outcome of this research was to develop a methodology for DH system optimisation.

5.5 RECOMMENDATIONS FOR INDUSTRY/FURTHER RESEARCH

Although less than 2% of the heat in the UK is currently supplied by DH, this study confirmed that DH can help the UK face its three energy challenges: Climate change, security of supply and energy prices. Operators, consultants and the Government can refer to this thesis to assist with future operating strategies, policies and regulations. The UK Government is already in favour of implementing DH system, but its implementation is not yet well enabled and analysis suggests that the Government should give further incentives to DH system operators. Woods (2013) proposes to incentivise DH through DH Incentive that would make payments retrospectively on an annual basis according to the amount of CO₂ emissions

saved. However, this thesis encourages not only Brussels but also the UK Government to tax CO₂ emissions and to follow Sweden and Denmark as leaders. Indeed, instead of giving incentives to the DH system operators, the Government could tax CO₂ emissions and give incentives to fuel poor home owners by retrofitting their homes and to industries to keep their competitiveness.

The UK Government should fix further regulations on DH system and could refer to this thesis when improving DH policies. Furthermore, this thesis recommends DH system operators to avoid wasting energy by operating their DH system inappropriately and to make use of the right resources for the right application at the right time.

In this transition to a 100% RE economy, nuclear energy should be used to generate a base electricity load. This would reduce the electricity peak demand to be met by renewables. After 2050, to mitigate nuclear energy dependence, nuclear power generation could then be progressively phased out by increasing the total capacity of renewable energy and energy storage.

5.6 CRITICAL EVALUATION OF THE RESEARCH

The aim of this thesis was accomplished. However, more case studies could have been analysed and implementing the findings from the proposed strategy to a real life case study would have showed the benefit from optimising a DH system.

Only four case studies were investigated because DH system's operators are very reluctant in sharing their confidential data due to their business model being built on profiting from selling heat to their consumers. However, PDHU is a non-profit establishment and the operators were very enthusiastic about sharing their data with the aim of better understanding the operation of their plant and reducing their heating cost.

Assessing the operational performance of DE technology can be a straight forward exercise. However, to assess the operational performance of a DH system was very challenging. Firstly, a DH system involves four components. Secondly, an advanced thermodynamic calculation method, exergy efficiency, was used to assess and optimise a DH system. Finally, DE and DH system must be integrated into the local and national energy sector while aiming to generate heat and electricity at a cheaper rate and minimising its CO₂ emissions.

In conclusion, the goal from this Engineering Doctorate was achieved. Firstly, it gives the guidance to practitioners and consultants to design and operate DH systems. Secondly, it amplifies the necessity to analyse the performance of DE systems. Finally, it confirms that CHP - DH can help to balance national electricity generation with demand and reduce national CO₂ emissions.

6 REFERENCES

AGEEstat, 2012. Development of renewable energy sources in Germany 2011. Available from: <http://www.bbc.co.uk/news/uk-scotland-13253876> [viewed 30-03-2014 at 13:53]

Adenle, A., Haslam, G., Lee, L., 2013. Global assessment of research and development for algae biofuel production and its potential role for sustainable development in developing countries. *Energy policy*, **61**(2013), pp. 182-195.

Alprofits, 2014. Second generation biofuels. Available from: <http://www.altprofits.com/ref/se/re/bio/sgb/sgb.html> [viewed 10-07-2014 at 16:25]

Basu, P., 2013. Biomass gasification, pyrolysis and torrefaction. London: Academic Press.

BBC News Scotland, 2011. Scots windfarms paid cash to stop producing energy. Available from: http://www.erneuerbare-energien.de/fileadmin/Daten_EE/Bilder_Startseite [viewed 31-03-2014 at 14:19]

Benonysson, A., Bøhm, B. and Ravn, H., 1995. Operational optimization in a district heating system. *Energy Conversion and Management*, **36**(5), pp. 297-314.

Bolton, P., 2013. Energy imports and exports. London: House of commons Library.

Bioenergy conversion factors, 2014. Viewed on [14-05-2014] and available from: https://bioenergy.ornl.gov/papers/misc/energy_conv.html.

Bøhm, B., Gabrielaitiene, I., 2007. Modelling temperature dynamics of a district heating system in Naestved, Denmark—A case study. *Energy Conversion and Management*. Vol. 48, No. 1, 78-86.

Borel, L. and Favrat, D., 2010. Thermodynamics and energy systems analysis – From energy to exergy. Lausanne: EPFL.

Biofuel, 2014a. First generation biofuels. Viewed on [10-07-2014] and available from: <http://biofuel.org.uk/first-generation-biofuel.html>

Biofuels, 2014b. Third generation biofuels. Viewed on [10-07-2014] and available from: <http://biofuel.org.uk/third-generation-biofuels.html>

Boardman, B., 2010. *Fixing fuel poverty – Challenges and solutions*. London: Earthsan.

Braun, J. and Lawrence, T., 2004. Demonstration of load shifting and peak load reduction with control of building thermal mass. ACEE summer study on energy efficiency in buildings.

Buro Happold, 2009. Image from Buro Happold project.

Camco, 2012. Energy bill revolution campaign report. London: Camco.

CIBSE, 2013. AM12: *Combined heat and power for buildings*. London: The Chartered Institution of Building Services Engineers.

CleanTechnica, 2014. Viewed on [15-06-2014] and available from: <http://cleantechnica.com/2013/02/15/nec-and-acea-to-provide-energy-storage-systems-for-rome-smart-grid-project/>

Climate Change Act, 2008. *Carbon targeting and budgeting*, Chapter 27, Part 1 – the targets for 2050, Her Majesty's Stationery Office Limited, London, UK

CCC, 2008. *Building a low-carbon economy - the UK's contribution to tackling climate change*, London: Committee on Climate Change.

Davito, B., Tai, H., Uhlener, R. 2010. The smart grid and the promise of demand-side management. San Francisco: McKinsey & Company.

DEA, 2012. *Energy policy in Denmark*. Copenhagen: Danish energy agency.

Donald, L., 1998. Biomass for renewable energy, fuels, and chemicals. California: Academic press.

DECC, 2003. *The future of Heating: Meeting the challenge*. London: Department of Energy & Climate Change.

DECC, 2009. *Climate change act 2008 Impact Assessment*. London: Department of Energy & Climate Change.

DECC, 2012. Renewable heat incentives: Expanding the non domestic scheme. London: Department of Energy & Climate Change.

DECC, 2013a. *UK energy in brief 2012*. London: Department of Energy & Climate Change & Climate Change.

DECC, 2013b. UK greenhouse gas emissions: performance against emissions reduction targets – 2012 provisional figures. London: Department of Energy & Climate Change & Climate Change.

DECC, 2013c. *Fuel poverty: A framework for future Action*. London: Department of Energy & Climate Change.

DECC, 2013d. The government's standard assessment procedure for energy rating of dwellings. Watford: Department of Energy & Climate Change.

DECC, 2013e. Domestic Renewable Heat Incentive. London: Department of Energy & Climate Change.

DECC, 2013f. Non-domestic renewable heat incentive. London: Department of Energy & Climate Change.

DECC, 2013g. Energy consumption in the UK (2013). London: Department of Energy & Climate Change.

DECC, 2013h. UK renewable energy Roadmap- Update 2013. London: Department of Energy & Climate Change.

DCLG, 2014. House buildings: March quarter 2014, England. London: Department for Communities and Local Government.

European commission, 2008. EU action against climate change – The EU Emissions Trading Scheme. Brussels: environment.

DHC+, 2009. *District heating cooling*. Brussels: DHC+ Technology Platform.

EG&G Technical Services, 2002. Fuel cell handbook – Sixth edition. West Virginia: U.S. Department of energy.

Ener-G, 2014. E230 Natural gas CHP unit - Technical datasheet. Stamford: Ener-G.

Energy Act 2008, 2014. Retrieved on [14-07-2014] and available from: http://www.legislation.gov.uk/ukdsi/2014/9780111113936/pdfs/ukdsi_9780111113936_en.pdf?text=%22renewable%20heat%20incentive%22

EnergyPro, 2012. Download energyPRO 4. EMD International A/S, 2012.

Facchinetti, E., Favrat, D., Marechal, F., 2011. Innovation hybrid cycle solid oxide fuel cell-inverted gas turbine with CO₂ separation. Weinheim: Wiley online library.

Favrat, D., Marechal, F., Epelly, O., 2008. The challenge of introducing an exergy indicator in a local law on energy, *Energy*, 33(2), pp. 130-136.

FPAG, 2012. Tenth annual report. London: Fuel poverty advisory group (for England).

Francis, 1992. How to get a PhD – a handbook for students and their supervisors, 2nd Edition, Open University Press

GasTec, 2010. At CRE, Heat metering for the RHI, DECC, September 2010

GE Sensing, 2005. TransPort PT878 Panametrics Portable Ultrasonic Liquid Flowmeter, 2005. Available from www.gesensing.com.

GLA, 2007. The Mayor's climate change action plan. London: Greater London Authority.

GLA, 2010. Delivering London's Energy Future, London: Greater London Authority.

Hawkey, 2009. Will "district heating come to town"? Analysis of current opportunities and challenges in the UK. University of Edinburgh: School of Geosciences.

Heat 2014 Blog. Viewed on [21-05-2014] and available from <http://www.heatconference.co.uk/index.php/blog/entry/are-we-getting-the-best-value-for-money-from-green-subsidies>

Heywood, J., 1988. Internal combustion engine fundamentals. Singapore: McGraw-Hill Book Company.

Hills, J., 2012. Getting the measure of fuel poverty. London: Department of Energy & Climate Change.

HM Government, 2006. *The energy challenge*. Norwich: Department of trade and industry.

HM Government, 2009. *The UK low carbon transition plan*. Richmond: Policy Team.

HM Government, 2013. The UK's nuclear future. London: Department for business, innovation and skills.

Hua, Y., 2013. Understanding POE for future building practices. Editorial for the Special Issue on Post-Occupancy Evaluation (POE). *Intelligent Buildings International*. Vol.5, No.3, 133-134.

ICPC, 2009. Submarine cables and the oceans: connecting the world. Lymington: International Cable Protection Committee Ltd.

IEA, 2008. District Heating Distribution in Areas with Low Heat Demand Density. Sittard: International energy agency.

IEA, 2011a. District heating for energy efficient building areas. Sittard: International energy agency.

IEA, 2011b. Energy policies of IEA countries – Denmark. Paris: International energy agency.

Karlsson, J., 2012. Possibilities of using thermal mass in buildings to save energy, cut power consumption peaks and increase the thermal comfort. Lund: Lund institute of technology.

Kolanowski, B., 2011. Small-scale cogeneration handbook. London: Fairmont press.

Kutz, M., 2007. Alternative energy production. New Jersey: John Wiley & Sons.

Lboro, 2013. Viewed on [22-03-2014] and available from <http://www.lboro.ac.uk/service/fm/>

Leyzerovich, A., 2007. Steam turbines for modern fossil fuel power plants. Lilburn: The Fairmont press. Massachusetts: Scrivener publishing LLC.

Lowen, J., Stevenson, A., 1990. Operation of Dinorwig pumped storage station on the UK national grid system. London: Thomas Telford.

Martin-Du Pan, O., Bouchlaghem, D., Eames, P., Young, A., Gill, Z., 2011. Post occupancy evaluation of decentralised energy systems. Sustainability in energy and buildings, SEB'11 – 2011, Marseille, France.

Martin-Du Pan, O., Eames, P., Bouchlaghem, D., Cooke, H., Young, A., 2012. A decentralised energy system contribution towards a low carbon economy – UK. 7th International conference on innovation in architecture, engineering & construction: 15-17 August, The Brazilian British Centre, São Paulo, Brazil.

Martin-Du Pan, O., Eames, P., Bouchlaghem, D., Rowley, P., Susman, G., 2014. Current and future operation scenarios for a 50,000 MWh district heating system. Architectural engineering and design management, <http://dx.doi.org/10.1080/17452007.2014.899889>.

Martin-Du Pan, O., Eames, P., Rowley, P., Bouchlaghem, D., Susman, G., 2014. Comparison and exergy analysis of heat supply scenarios for a 50,000 MWh district heating system, EuroSolar, the 8th international renewable energy storage conference. 7-8 November Berlin.

Martin-Du Pan, O., Eames, P., Rowley, P., Bouchlaghem, D., Susman, G., 2014. District heating optimisation. The 14th international symposium on district heating and cooling. DHC+ technology platform. 7-9 September 2014: Stockholm

Martin-Du Pan, O., 2015. Heat losses in district heating systems and heat meters (Abstract). International conference on smart energy systems and 4th generation district heating. 25-26 August 2015: Copenhagen.

METOFFICE, Retrieved May 25, 2013, from <http://www.metoffice.gov.uk/climate/uk/so/print.html>

MicroDAQ, 2013. Viewed on [30-05-2013] and available from <http://www.microdaq.com/occ/accessories/extensors.php>

Mousdale, D., 2012. Biofuels – Biotechnology, chemistry, and sustainable development. Boca Raton: CRC Press.

Mudhoo, A., 2012. Biogas production – Pretreatment methods in anaerobic digestion.

NAG, P., 2002. Basic and applied thermodynamics. Delhi: Tata McGraw-Hill Publishing Company Limited.

Naik, S., Goud, V. Rout, P., Dalai, A., 2009. Production of first and second generation biofuels: A comprehensive review. Renewable and sustainable energy reviews, 14, pp.578-597.

National grid, 2012. UK future energy scenarios. Warwick: National grid plc.

National Statistics, 2013. Digest of United Kingdom energy statistics 2013. London: TSO.

Ofgem, 2010. Renewables obligation – Annual report 2010-11. London: Ofgem.

Palsson, O. and RAVN, H., 1994. Stochastic heat storage problem—solved by the progressive hedging algorithm. *Energy Conversion and Management*, **35**(12), pp. 1157-1171.

Pöyry, 2009. The potential and costs of district heating networks. London: Department of energy and climate change.

Rajaram, V., 2012. From landfill gas to energy technologies and challenges. London: CRC Press/Balkema.

REFUNA, 2014. Fernwärme - Die Komfort-Energie. Regionale Fernwärme. Available from: <http://www.wiona.refuna.ch/> [viewed on 30-03-2014 at 21:06].

Reuters, 2014. UK could produce shale gas in 4 years in emergency. Available from: <http://uk.reuters.com/article/2014/04/02/ukraine-crisis-shale-idUKL5N0MT36Z20140402> [viewed on 10-07-2014 at 15:33]

Reidhav, C., Werner, S., 2008. Profitability of sparse district heating. *Applied energy*, vol. 85, no. 9, pp 867-877.

Risoe, 2004. Simple models of district heating systems for load and demand side management and operational optimisation. Technical University of Denmark: Department of mechanical engineering.

Roberson, J., Homan, G., Mahajan, A., Webber, C. A., Nordman, B., Brown, R., McWhinney, M. and Koomey, J., 2002. *Energy Use and Power Levels in New Monitors and Personal Computers*. LBNL-48581, Lawrence Berkeley National Laboratory, California.

Schiffmann, 2008. Integrated design, optimization and experimental investigation of a direct driven turbocompressor for domestic heat pumps. Lausanne: EPFL.

Schneider-electric, 2014. Termis software. Viewed on [01-04-2014 at 14:07] and available from: <http://www.schneider-electric.com/products/ww/en/5100-software/5125-information-management/61418-termis-software/>

Siemens Steam Turbines, 2014. Viewed on [27-07-2014 at 11:50] and available from: <http://www.energy.siemens.com/co/en/fossil-power-generation/steam-turbines/>

Tagliaferro, L., 2003. Thomas Edison – Inventor of the age of electricity. Minneapolis: Linda Tagliaferro.

The Guardian, 2014. French firm Total to join UK shale gas. Viewed on [10-07-2014 at 15:39] and available from: <http://www.theguardian.com/environment/2014/jan/11/french-total-uk-shale-gas-exploration>

Thumann, A., 2009. *Handbook of Energy Audits*, Eight edition. London: Taylor & Francis.

Termis, 2014. Schneider electric. Available from and viewed on [02-06-2014 at 18:10] <http://www.schneider-electric.com/products/ww/en/5100-software/5125-information-management/61418-termis-software/>

Toke, D. and Fragaki, A., 2008. Do liberalised electricity markets help or hinder CHP and district heating? The case of the UK. *Energy policy*, 36(4), pp.1448-1456.

U.K. National Grid Status, 2014. Available from: <http://www.gridwatch.templar.co.uk> [viewed 25-03-2014 at 13:35]

UNFCCC, 2009. Framework convention on climate change. Copenhagen: Conference of the parties.

Veolia, 2014. Veolia environment services. Viewed on [01-07-2014 at 13:33] and available from: <http://www.veoliaenvironmentalservices.co.uk/Sheffield/>

Venn, F., 2002, The oil crisis. United Kingdom: Licensing Agency.

Walsh, P., 2004. Gas Turbine performance. Australia: Blackwell.

Wagemans, C., 1991. Nuclear fission process. Florida: Library of congress cataloguing-in publication data.

Wartsila, 2014. Products from Wartsila. Viewed on [21-07-2014] and available from: <http://www.wartsila.com/en/products>

Werner, S., 2003. Obstacles and possibilities with district heating in low heat density areas. Lund: Lund University of technology.

Werner, S., 2013. District heating and cooling. Sweden: Exaktaprinting AB.

Wernstedt, F., Davidsson, P., Johansson, C., 2007. Demand side management in district heating systems. The sixth International conference on autonomous agents and multi-agents systems.

Wigbells, M., Bøhm, B. and Sipilae, K., 2005. *Dynamic Heat Storage Optimisation and Demand Side Management*. 1313-02-01-10-006/4700005181. Paris: IEA.

World Nuclear Association, 2014. Nuclear power in Russia. Available from: <http://www.world-nuclear.org/info/Country-Profiles/Countries-O-S/Russia--Nuclear-Power/> [viewed 30-03-2014 at 21:17]

Yamin, F., 2005. Climate change and carbon markets. London: Earthscan.

Yin, R., 2003. *Case study research: Design and methods, 3rd edition.* London: SAGE Publications.

APPENDIX A POST OCCUPANCY EVALUATION AND HEAT METERS

APPENDIX A1 POST OCCUPANCY EVALUATION OF DECENTRALISED ENERGY SYSTEMS (PAPER 1)

Full Reference

Martin-Du Pan, O., Bouchlaghem, D., Eames, P., Young, A., Gill, Z., 2011. Post occupancy evaluation of decentralised energy systems. *Third International Conference in Sustainability in Europe and Buildings, SEB'11*. 1-3 June. Marseille, France.

Abstract

This work introduces the theory involved in a decentralised energy system, such as a district heating system, going from its implementation and viability to its system performance. Some case studies across Europe have been selected and compared; this comparison demonstrated a lack of results regarding the actual overall performance occurring in a district heating system. The Affordable Housing site located in Suffolk is made up of 26 individual homes with a district heating network supplied with a biomass boiler. This study investigates how well this district heating distributes its heat. A system performance analysis has been performed and its losses determined and introduced.

1 Introduction

A district heating (DH) or cooling system is a centralised system used for distributing heat and/or coolth to different buildings, such as: residential, commercial, industrial. These three types of buildings require domestic hot water (DHW), space heating (SH) and/or space cooling; in addition to these demands, industrial buildings might as well require the district system for industrial processes.

The heat is often obtained from a centralised cogeneration plant burning natural gas (NG). The produced heat is then distributed to customers through a network of insulated pipes. A district system network consists of supply and return lines. Water and steam are used as the common medium for the heat distribution. The advantage of steam is that it can be used in industrial processes when higher temperatures are required.

The aim of this research it to verify if the theory and practice agree; for example, if theoretically a development is assumed to reduce of 40% its carbon emission through its DH system, does it really manage to perform as well? This preliminary study highlights the lack of data regarding the overall efficiency of a DH system and how poorly efficient a DH system can perform when not well designed.

2 Design of District Heating Network – Theory

As shown in Figure 1, a DH system is constituted of a supply and return pipe. The supply pipe in a district heating network (DHN) can deliver superheated water at approximately 120°C, but usually delivers heated water in the range of 65-95°C to the customers and the return pipe returns to the energy plant the cooled water at a temperature still higher than the ambient environment. In hot-water systems, the transmission via pipes is effective typically for distances up to ~25km. However, steam systems usually have ranges of only ~5km, although newer steam systems can have longer ranges (Babus'Haq et al. 1990). DH systems also exist in smaller scales and are named community heating.

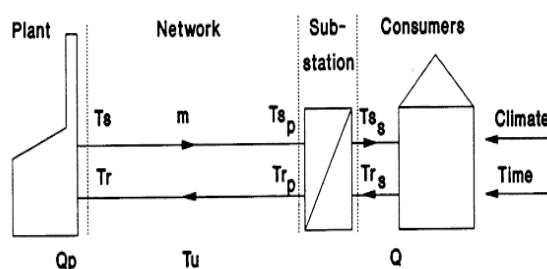

Figure 1: A schematic diagram of a DH system (Bøhm et al. 2002)

2.1 Technology

The hot water supplied to a DHN is often produced from a cogeneration energy plant and is pumped to every connected customer. A cogeneration energy plant includes boilers and at least one cogeneration energy unit described here below.

At the customer level, the individual central heating is usually connected to the DH by an open or closed heat exchanger placed in a substation. As a general point, major scales DH are much more likely to be sourced from a much more sustainable methodology, such as: waste heat dumping from a power station or incinerators.

2.1.1 Boilers

A boiler consists of a closed vessel in which water, steam or an other fluid is heated. The heated fluid is then pumped for use in various processes or heating applications. In the DH technology, the boiler, placed in an energy centre, is required for heating water that will then be pumped through pipes to heat up consumers in a district or a community, see Figure 1. A boiler can use a different methodology to heat up its enclosed liquid, such as in a conventional boiler or a condensing boiler. A condensing boiler extracts additional heat from the waste gases by condensing the water vapour to water: by recovering this latent heat, the boiler's efficiency can be increased by as much as 10%. Moreover, boilers can be supplied from different fuels, such as: natural gas, oil, biomass or coal.

Finally, a boiler being fed by a gas, a liquid or a solid fuel will all show a different morphology and a boiler being supplied by a renewable source, such as biomass can be carbon neutral.

2.1.2 Cogeneration

Cogeneration is the simultaneous production of electricity and heat and is also called combined heat and power (CHP). The central and most fundamental principle of cogeneration is that, in order to maximise the many benefits that arise from it, cogeneration system should be sized according to the heat demand of the application. Through the utilisation of the heat, the efficiency of a cogeneration plant can reach 90% or more. As cogeneration is the most effective and efficient form of power generation, cogeneration brings an opportunity to move towards more decentralised forms of electricity generation, where energy plants are designed to meet the needs of local consumers, providing high efficiency, avoiding transmission losses and increasing flexibility in system use (COGEN Europe 2009). As shown in Figure 2, there exists at present four different technologies to produce electricity and heat simultaneously: Engine/Generator, Gas Turbine/Generator, Fuel cell and Steam Turbine/Generator.

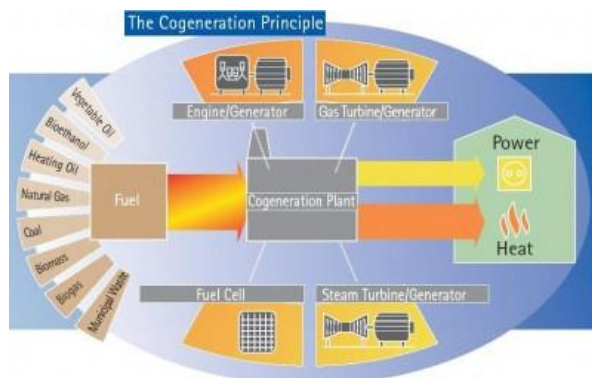

Figure 2: The cogeneration principle (COGEN Europe 2009)

2.1.3 Thermal Energy Storage

Due to the fact that consumption of electricity and heat may not vary simultaneously, the installation of a heat store may be of great advantage. Indeed, the heat store is used to supply the DH system when the CHP plant is producing electric power alone and also to redistribute optimally over time the required heat production (Palsson and Ravn 1994).

In summary, the installation of a heat store yields several important benefits. It can be used:

- To cover temporary heat load peaks, instead of starting a potential back-up heat source;
- To counter-balance the thermal output of the boiler and thereby improve the combustion efficiency, due to fewer operation starts and stops;
- As a heat reserve source in case of service interruptions or breakdowns;
- As a self-circulated cooling buffer for the heat recovery unit if the circulating pumps happens to disagree;

- To store some heat at night and to use it during the day as commercial electricity rates are lower at night.

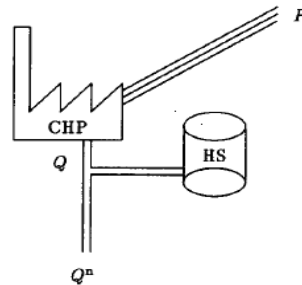

Figure 3: A sketch of a CHP plant with heat storage (Palsson and Ravn 1994)

2.2 Carbon Dioxide Emissions

Carbon dioxide (CO₂) emissions' in all individual and DH systems are very variable. Indeed, CO₂ emissions depend greatly on the efficiency of the load equipment. Moreover, the equipment efficiency may vary when it is used at partial load or at full load or if it has just started and has not yet had the chance to heat up. In other words, the CO₂ emissions vary greatly depending on how the equipment is used. Furthermore, the CO₂ emissions are dependent on the fuel sources including their heat source efficiency and their delivery efficiency.

According to The Government's Standard Assessment Procedure for Energy Rating of Dwellings report (DECC 2009a), the natural gas combustion in the UK produces 0.198 kg CO₂ per kWh of produced heat; and 0.517 kg CO₂ is produced for every generated kWh of national grid electricity.

Similarly, the CO₂ emissions per kWh of produced heat from combusting biomass and delivered through a DH is equal to 0.013 kg CO₂ per kWh of heat.

Please note that a decentralised energy system supplying a site with heat and electricity does usually not supply the totality of the electrical demand, thus the connection to the national grid is inevitably still necessary.

2.3 Planning District Heating Systems

Although in built-up areas DHN offer lower carbon abatement costs than the other low carbon technologies, planning to implement DHNs to a city can be quite a stringent task. Indeed, their incorporation is guided by national and local policies and must be economically viable. Policies for their incorporation differ from city to city and very often appear as not very helpful and make every DH system uniquely constructed. Projects including DHN are not always the most profitable, but as summarised in (Hawkey 2009), DH help to achieve various policy goals such as emissions reductions, tackling fuel poverty and enhancing security of energy supply. For these reasons DHN is a very popular topic among governments.

DHN is only sometimes a very well implemented technology in countries and cities; this can be appreciated by observing the following respective percentages of DHN distribution in Finland, Denmark, Vienna, Netherlands and United Kingdom of 49%, 60%, 60%, less than 3.5% and less than 2% of heating demand. As shown, DHN is not always a very popular option and this is due to the high cost of the piping network compared to a conventional stand alone system operating individually on gas or electricity (Davies, Woods 2009).

2.3.1 Policies Across Europe

DHs have got an essential role in reducing carbon emissions and satisfying European policies. Indeed, DH carbon abatement is greater than for any stand alone technology as long as a DHN can achieve an 80% penetration in built-up areas (Davies, Woods 2009). Their analysis confirms that DHN is the preferred and most affordable option for achieving carbon reduction in dense areas unless the grid electricity emits less than 0.15kgCO₂/KWh; unfortunately, low grid carbon and fuel prices can't coexist and this eliminates the DHN redundancy potential, because of the Heat Pump or other technology operating on a decarbonised Grid.

In the United Kingdom

49% of the energy demand in the UK is attributed to supply heat for homes, businesses and industrial processes and this corresponds to 47% of the UK's CO₂ emissions (Davies, Woods 2009). To supply this demand and to reduce the carbon emission, the UK government is in favour of incorporating DHNs and is very active in encouraging the growth of DH-CHPs; the governmental measures are: financial incentives, grant support, a greater regulatory framework, and government leadership and partnership. In addition, local authorities promote the benefit of DH to potential users and very often start a project or enable an anchor load (a load above 200kW) to the DH project.

In 2008 under the Carbon Reduction Commitment (CRC) Energy Efficiency Scheme the UK committed to a further reduction and the UK must now reduce of 80% its carbon emissions by 2050 (DECC 2009b). This happened, because of the awareness of the alarming rate increase of the current CO₂ concentration.

To obtain this 80% national carbon reduction, almost no carbon emission will come from buildings' DHW and SH requirement.

2.3.2 Financial Viability

The main economic barrier to DHN is its high upfront capital costs: construction of the plant, heat network and the connections. Moreover, there is more uncertainty involved with this technology than with other large scale investments: the income is lower and there is a lengthy payback period. Nevertheless, investors are attracted by the longevity (lifespan of 40-50 years) of DHN projects (Hawkey 2009). In other words, DHN is a commercially poor investment, but it is more cost-effective than other low-or-no carbon technology option in built-up areas (Davies, Woods 2009). Furthermore, CHP-DHN combines well with other alternative technologies. Indeed, electricity generated from intermittent renewable energy

(RE) is not wasted if the operation of the CHP gives its priority to the electricity generated from the RE technology. This flexible generation capacity represented by CHP-DH will help in the reduction of costs associated with absorbing large quantities of fluctuating RE sources into the grid (Toke, Fragaki 2008). This happens in Denmark, decentralised CHP are able to respond in a flexible manner to changes in the outputs of RE such as wind. Indeed, excess wind reduces the price of the electricity. CHP's are then turned off and DH use heat from the thermal store, alternatively by using heat pumps.

2.4 Operational System Performance

The task of a DH system is to determine what kind of heat production unit should be built and to find the optimum temperature levels of water (Benonysson et al. 1995). Finding the optimum temperature level is a particularly challenging task, because of the dynamics of the DH system. Indeed, because of the transient nature of the DH system: transient heat load and transient supply temperature, time delays from the heat source to the consumer occur in the network: It can take up to 12 hours for a DH consumer to register a change in the supply temperature (Benonysson et al. 1995).

Furthermore, while optimising a DHN, one needs to consider the economic situation with periods with low price for the produced electricity, to periods when the price is higher. Indeed, the DHN will become more financially beneficial if it exports to the grid its produced electricity during periods with high electricity prices. In order to maximise this, the operator can produce some extra electricity during high electricity prices and store some heat for future heating demand; heat can be stored in a thermal tank and in the district network itself: the operator can increase its supply temperature and more heat will be stored in the network.

In summary, the operational optimisation or minimisation of the cost of DH calls for a very active control of the supply temperatures from the plant. The process of transporting the heat to the customers involves time dependent changes in flows and temperatures, as well as in the heat losses from the pipe network. These heat losses are kept at a minimum by lowering the supply temperature from the plant. However, the delivered supply temperature must ensure an acceptable temperature level at the customers. Please note as well, that if the supply temperature is reduced, the water flow in the system increases and this results in higher pumping costs. An appropriate balance between these different inputs is referred as operational optimisation of the DH supply temperature.

In order to determine the optimal supply temperatures for use in daily operation, it is necessary to have a model which adequately reflects the DH system and that can be solved within reasonable time. Two classes of models have mainly been used for DH systems: physical models and statistical models.

3 Literature Monitoring and Case Studies - Practice

The monitoring of the DH system varies from one energy plant to the other. The basic concept in monitoring the performance of a DH system is to use existing meters, sensors and already installed data collection system. In other words, data may be obtained from different instruments and will differ from one district system to the other. Based on available

Literature, four selected sites have monitoring data and reporting. This study will then compare these sites, by comparing their: location, scale, efficiency and monitoring strategies.

3.1 Naestved

Naestved is a town of 47500 inhabitants, located in the southern part of Zealand, Denmark. The DH system connects 3460 consumers. Today, 90% of the heat production comes from combined incineration and CHP plant, while the rest of the heat comes from natural gas; the maximum production is 66 MW. From (Wigbells et al. 2005), in the financial year 2003/2004 the annual heat production was 743 TJ, of which 601 TJ was sold to the consumers, resulting in a heat loss of 19% (Gabrielaitiene et al. 2007).

3.2 Hvalsoe

Hvalsoe is a small town of approximately 2500 inhabitants, situated about 40 km West of Copenhagen. Hvalsoe has his own DH system. The network of Hvalsoe supplies heat to 535 dwellings. All consumers use DH for both SH and for DHW. Most buildings are connected directly to the distribution system, but the larger buildings are connected through a heat exchanger and it has been further assumed that the secondary temperatures of the heat exchangers of all consumers were 60 and 40°C, respectively (Bøhm et al. 2002).

3.3 Ishoej

Ishoej is a suburb of Copenhagen and is located 17 km south-west of the city centre. The built up area consists mainly of blocks of flats, semidetached houses, institutions and shopping centres. The DH system was built in 1982. Today, 8000 dwellings, five schools and the city centre with many shops and institutions are supplied from the DH system. All consumers are indirectly connected through 23 substations (each substation consists of one or two plate heat exchangers). The network is made of preinsulated pipes from 48 to 356 mm. The total length of the network is approximately 8.3 km. As all connected buildings are situated within a small area, the line heat demand is high, approximately 42 GJ/m, and the annual heat loss, from the primary network, is approximately 3% (Bøhm et al. 2002).

3.4 Comparison

Table 3. 1 Literature case study comparison

Case Study	Country	Heat capacity [MW] / Heat production [GWh/yr]	What was measured?	Efficiency [%]
Naestved	Denmark	66 / 743,000	Heat supplied and consumed to the subsystem	81
Hvalsoe	Denmark	15 / 6	Heat production, supply and return temperature at the plant	--
Ishoej	Denmark	17 / --	The heat loads at the substations; and the plant's heat production	97*

*: Efficiency of primary network only

Please note that these three case studies are well established DHNs and only the DH in Naestved has its whole system efficiency determined. For this reason, there is a need to understand better the real life performance of DHNs.

4 Case Study: a UK Affordable Housing Site

The Affordable Housing site located in Suffolk consists of 26 individual dwellings (13-two bed, 9-three bed and 4-one bed dwellings). The project is intended to be an exemplar of sustainable development and the project won a Housing Design Award in October 2007. This site is equipped with a community energy system powered by a main biomass boiler (supplemented with gas boiler for peak load and back-up). This DH system provides heating and hot water for the dwellings. Hot water is provided by instantaneous water heaters in the dwellings ensuring a sufficient supply of hot water all year round. Radiators are used as the heat emitters, fitted with thermostatic radiator valves and controlled using a timer and a zoned thermostatic control. This ensures the heating system is used efficiently with little waste. Figure 4 illustrates the built schematic of the site's DHN.



Figure 4: The site's built schematic of the DHN

4.1 Measurements

Some manual measurements of the heat produced and the heat consumed on the DH have already been established: the heat output from the biomass and the natural gas boiler were measured manually on a monthly basis through a heat meter, and the heat consumed in the 26 households were taken on 6 months basis during 2 years.

Figure 5 gives the total heating demand from these 26 homes and the losses occurring in the system after the boiler's efficiency: the losses in the pipes, the thermal storage and the instantaneous water heaters.

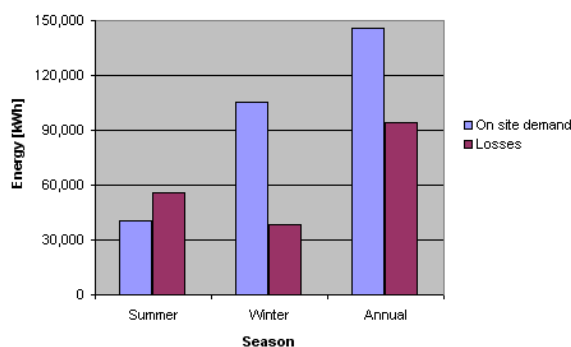

Figure 5: The site's seasonal DHW + SH consumption, from 1-4-2009 to 9-4-2009 (30-10-2009 half way through)

4.2 Results

As summarised in Figure 6, 180 MWh of heat was delivered during the monitored 433 days and this heat was delivered with a 60% efficiency. Based on one year data, Figure 5 quantifies the summer, winter and annual efficiency of this DH, and is of: 73%, 42%, and 60% respectively. The disappointing efficiency of this DH system is the topic of this research: it will concentrate on verifying if the monitored data corresponds to some theoretical data predicted by theoretical models. However, as demonstrated in Table 3.1, the efficiency of a

DH system can achieve 81% when well calibrated. A good calibration calls on controlling very actively the supply temperature and the water flow rate and this is calculated to keep the heat losses at a minimum. However, the delivered supply temperature must ensure an acceptable temperature level at all customers. Please note as well, that if the temperature is reduced, the water flow rate in the network increases, resulting in higher pumping costs. An appropriate balance between these different inputs is referred as operational optimisation of the DH supply temperature. Finally, this DH system operates at a very different efficiency between the summer and the winter; this difference is because in the summer there is no more SH demand, but only DHW demand, which corresponds to a low and irregular heat demand. However, this low efficiency in the summer could be improved by incorporating a thermal heat store within the DH system. This thermal storage would:

Cover a temporary heat demand instead of starting the biomass boiler;

Counter-balance the thermal output of the boiler and thereby improve the combustion efficiency, due to fewer operation starts and stops.

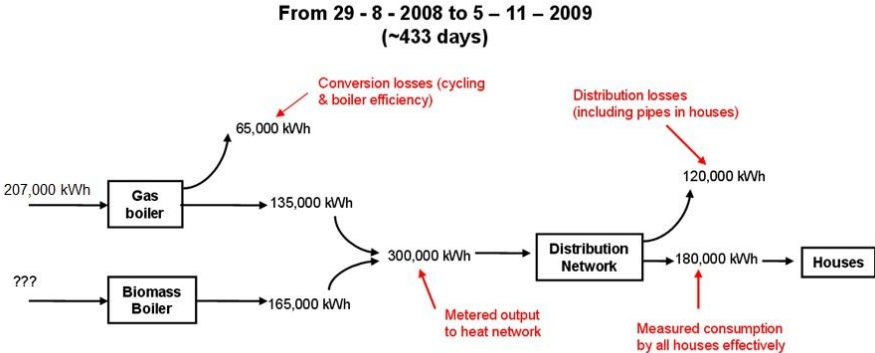

Figure 6: The development’s district heating network

5 Conclusion

Even though DH is an already well known and mature technology, post occupancy evaluation of this technology calls for further research and investigation. Indeed, previous studies in Europe looked into DH and have found good mathematical models to simulate and simplify a DHN, but very few of them have looked into concentrating over their overall efficiency and understand better their post occupancy evaluation. The Affordable Housing site located in Suffolk introduced in this research is a modern site where the DH efficiency has been calculated, and this disappointing 60% efficiency introduces further scope of work to look into: what design lessons/knowledge can be taken from an existing scheme to ensure high performance in new design and how can an already existing DH system improve its efficiencies?

References

- Babus'haq, R.F., George, H.E., O'callaghan, P.W. and Probert, S.D., 1990. Finite-difference technique for optimizing the locations of district-heating pipelines. *Heat Recovery Systems and CHP*, **10**(3), pp. 277-284.
- Benonysson, A., Bøhm, b. and Ravn, H.F., 1995. Operational optimization in a district heating system. *Energy Conversion and Management*, **36**(5), pp. 297-314.
- Bøhm, B, Kim, W., Kim, B., Koljonen, T., Larsen, H., Lucht, M., Park, Y., Sipilä, K., Wigbells, M. and Wistbacka, M., 2002. *Simple Models for Operational Optimisation*. 2002:S1. Paris: IEA.
- Cogen Europe, 07/02/2009, 2009-last update, What is Cogeneration? [Homepage of COGEN europe], [Online]. Available: <http://www.cogeneurope.eu/category/about-cogen/what-is-cogeneration/> [10/01, 2011].
- Davies, G. and Woods, P., 2009. *The Potential and Costs of District Heating Networks*. 204. Oxford: Pöyry Energy.
- DECC, 2009a. *The Government's standard Assessment Procedure for Energy Rating of Dwellings*. 9.90. Garston, watford WD25 9XX: BRE.
- DECC, 2009b. *Impact Assessment of the Climate Change Act*. 08. London: .
- DECC, 2006. *Climate Change - The UK Programme 2006*. CM6764 - SE/2006/43. London: TSO.
- Gabrielaitiene, I., Bøhm, B. and Sunden, B., 2007. Modelling temperature dynamics of a district heating system in Naestved, Denmark—A case study. *Energy Conversion and Management*, **48**(1), pp. 78-86.
- Hawkey, D.J.C., 2009. *Will "District Heating Come to Town"? Analysis of Current Opportunities and Challenges in the UK*, University of Edinburgh.
- Palsson, O. and Ravn, H., 1994. Stochastic heat storage problem—solved by the progressive hedging algorithm. *Energy Conversion and Management*, **35**(12), pp. 1157-1171.
- Toke, D. and Fragaki, A., 2008. Do liberalised electricity markets help or hinder CHP and district heating? The case of the UK. *Energy Policy*, **36**(4), pp. 1448-1456.
- Wigbells, M., Bøhm, B. and Sipilae, K., 2005. *Dynamic Heat Storage Optimisation and Demand Side Management*. 1313-02-01-10-006/4700005181. PARIS: IEA.

APPENDIX A2 HEAT LOSSES IN DISTRICT HEATING SYSTEMS AND HEAT METERS (ABSTRACT - SUBMITTED)

Full Reference: Oliver Martin-Du Pan, Heat losses in district heating systems and heat meters. E.ON-UK. oliver.martin-du-pan@eon-uk.com, +44 (0)78 133 69 246, 47-53 Charterhouse Street - London EC1M 6PB.

Abstract

The monitored heat losses of district heating systems in the UK are high and this can be explained because of their poor designs and operations. The design could be improved to reduce the heat losses by:

- Improving the insulation level; 40 mm insulating foam on all pipes.
- Reducing the number of heat exchangers that are installed between the supply unit and the end-users. This would firstly avoid their heat losses and would secondly enable to reduce the supply temperature from the energy centre to the substations and the consumers.
- Supplying heat from a substation to the end-users with the use of a double pipe configuration instead of a single oversized pipe. As a pipe heat losses increase linearly with the flow temperature and its diameter, a double pipe configuration could reduce the heat losses by pumping a lower flow temperature for the space heating and operating a single pipe of reduced diameter during the summer season.
- Reducing the length of the service pipes. The service pipes are the pipes connecting the DH network to the substations and the pipes connecting the laterals to every consumer's heat interface unit.

The current heat losses could also be reduced by minimising the operational cost to pump the heat to the consumers. This operational cost includes the electricity required for pumping and the heat losses to the environment and it may be minimised by controlling both the flow rate and the supply temperature in every circuit.

This study confirms that the heat consumption by consumers' heat interface unit heat meter is under monitored. Thus, the operational cost minimisation of a DH system becomes very challenging.

This study compares the heat losses reduction from a DH system composed of 587 flats distributed throughout 6 Blocks and connected with 5 substations. Originally, the centrifugal pumps in the Blocks' substations were operating at maximum velocity. Also, the energy centre did not pump the DH flow at a constant temperature and the secondary flow would then vary in temperature from approximately 60°C to 67°C and cooling of less than 1.5°C. The original operation of the DH system was modified in September 2014 by controlling the pumps in the energy centre to operate with a differential pressure set at 0.5 bar while supplying the heat at an increased temperature of 80°C. The pumps supplying the heat in a first Block was then also set to operate as the pumps in the energy centre but to supply the heating flow at a constant 75°C. Progressively during the month of October, the other Blocks connected to the DH system were at their turn also set to operate as such. However, as the energy plant generates heat with an undersized CHP engine and oversized boilers and does

not make use of its thermal store, the energy centre is still unable to maintain a flow of 80°C during the morning peak load. The Figure hereafter shows the billed heat losses reduction that was finally achieved by increasing every flow supply and cooling temperatures. In summary, although the “real” heat losses to the environment increases by supplying heat at a higher temperature, the billed heat losses reduces of approximately 20% by increasing the cooling of the DH flow and supplying the heat at a constant temperature.

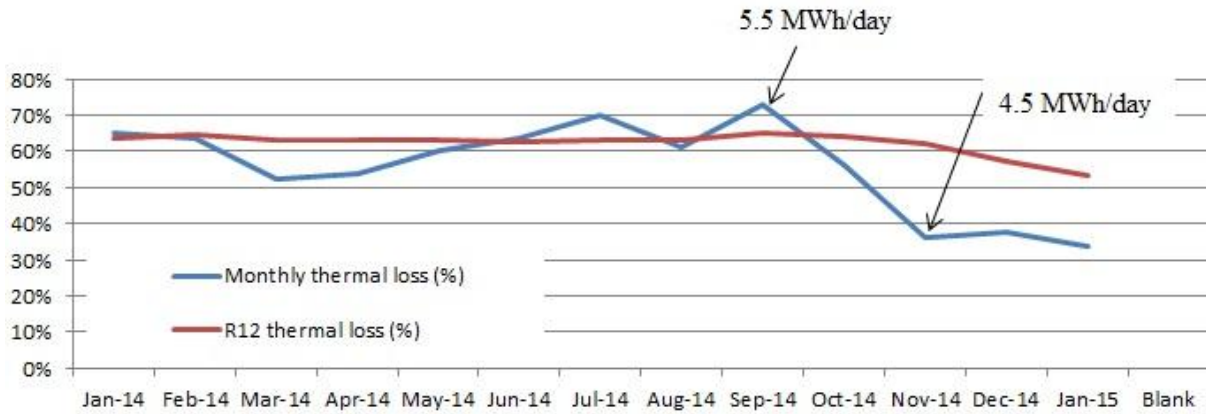

APPENDIX B A DECENTRALISED ENERGY SYSTEM CONTRIBUTION TOWARDS A LOW CARBON ECONOMY - UK (PAPER 2)

Full Reference

Martin-Du Pan, O., Bouchlaghem, D., Eames, P., Cooke, H., Young, A., 2011. A decentralised energy system contribution towards a low carbon economy –UK. 7th International conference on innovation in architecture, engineering & construction: 15-17 August, The Brazilian British Centre, São Paulo, Brazil.

Abstract

In order to meet the energy demands of London's homes, business and infrastructure through the provision of an efficient, affordable and secure supply of low and zero carbon energy, the Mayor of London plans to deliver 25% of London's energy needs through decentralised systems by 2025. Decentralised energy (DE) is the local supply of heat and power from an energy generation source to end users. This plant is often located in an energy plant containing a combined heat and power (CHP) installation as the lead heat source, and a back-up boiler for providing additional heat. A network of insulated pipes transports the heat from the energy centre to where the heat is used. DE also includes the generation of power into the local distribution network. DE is usually produced close to where it is used and cuts the energy wastage by improving the efficiency of supply, thus reducing carbon emissions and costs. Moreover, as well as reducing CO₂ emissions by moving the electricity supply from inefficient power stations, generating electricity onsite can reduce energy costs for the consumer. A whole range of power plants, including gas, oil, biomass, waste, etc., can be used in CHP mode. This paper discusses the drivers for a low carbon economy in the UK and illustrates the difficulties associated with the operation of a CHP engine using a case study. Hence, many buildings in London do include a CHP engine, but do not operate it because it is not regarded to be financially beneficial. To undertake a cost analysis, a hotel made up of 785 rooms located in central London is used as a case study. Finally, the CO₂ emission saving with the use of the CHP engine is also quantified.

Keywords

Combined heat and power, decentralised energy, renewable obligation

1 Introduction

District heating (DH) is defined as the local supply of heat from an energy plant to end users. This plant often includes a CHP unit operating as the lead heat source and an accumulator for storing the heat produced by the CHP unit and boilers to meet the heating load demand. A network of insulated pipes transports the heat from the energy source to where the heat is used. Decentralised energy (DE) differs from the concept of DH as it also covers the generation of power into the local distribution network. In DE, the energy is produced close to

where it is used. As shown in Figure 1, it also provides a fuel-flexible infrastructure that can allow fossil fuels to be replaced by renewable fuels in the future and as new technologies are developed. A DH system includes 3 elements: Production, Distribution and Delivery.

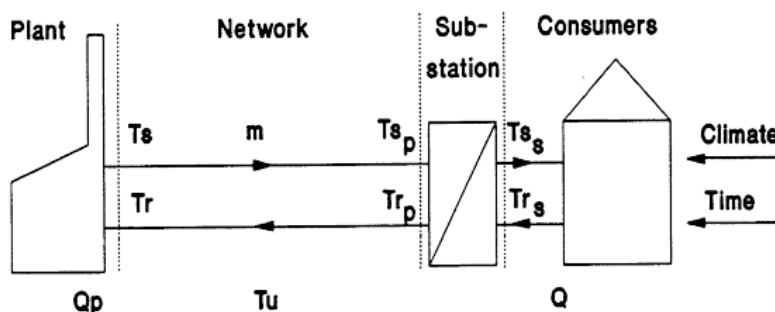

Figure 1: A schematic diagram of a DH system (Bøhm et al. 2002)

As the plant is separated from the consumers, DH enables whole communities to benefit from new and emerging technologies and any system changes will not cause any disruption to residents. DH is best installed in an area with a high concentration of heat demand. Moreover, DH can offer ways of supplying low-carbon or renewable heat to buildings with spatial constraints. Furthermore, the use of CHP fired by renewable fuels is expected to grow in the medium term through technologies such as:

- Gasification of wood chip to produce synthetic gas;
- Combustion of biomass (Rankine cycle);
- Engine with liquid biofuels.

A CHP unit is optimally sized to meet the base load and a proportion of the seasonal space heating demand. In operation, the CHP can either modulate with the heating load or a thermal storage can be used to supply the produced heat to the DH network when the CHP plant is producing electric power alone or to optimally redistribute the produced heat over a period of time (Palsson, Ravn 1994).

2 Drivers Towards a Low Carbon Economy

In 2011, the UK was the world's 7th greatest producer of man-made carbon emissions; producing around 1.8% of the total emissions generated from fossil fuels, see Figure 2. However, the UK is now responding to the drive for a Low Carbon Economy (LCE). A LCE seeks to minimise the output of greenhouse gas (GHG) emissions into the environment. Scientific evidence suggests that GHG emissions due to human activity are causing global warming and scientists are concerned about the negative impacts of climate change on humanity in the foreseeable future. Thus, the UK government is seeking to deliver a LCE to limit climate change. Accordingly it has set targets for reducing carbon dioxide emissions using the 1990 emissions as a baseline where the UK emitted an estimated 778 MtCO₂. There are currently 3 binding targets for UK emissions:

- In 1997, the Kyoto Protocol set a target for the UK to cut its CO₂ emission by 12.5% by 2012

- The Climate Change Act 2008 introduced a legal obligation for the UK to cut CO₂ emissions by (DECC 2009a):
 - 33% by 2020
 - 80% by 2050

In March 2006, after the publication of Energy White Paper (DEFRA 2003)); and guided by the 2006 Energy Review (HM Government 2006), the Government Updated the 2000 Climate Change Programme. This updated programme provided a framework and a comprehensive strategy for a more sustainable future by committing the UK to reducing its emissions by 60% by 2050 with a real progress by 2020. These initiatives led to the current energy policy set out in the Energy White Paper of July 2009: “The UK Low Carbon Transition Plan” (HM Government 2009) and The Climate Change Act 2008 that became law on 26 November 2008. In summary, “The UK Low Carbon Transition Plan” outlines the Government international and domestic strategy for responding to the following challenges:

- To cut carbon emissions;
- To ensure secure, clean and affordable energy.

The Climate Change Act 2008 makes it the duty of the Secretary of State to ensure that the net UK carbon that accounts for all six Kyoto greenhouse gases for the year 2050 is at least 80% lower than the 1990 baseline. The Act aims to enable the United Kingdom to become a LCE and gives ministers powers to introduce the necessary measures to achieve a range of GHG reduction targets. An independent Committee on Climate Change has been created under the Act to provide advice to UK Government on these targets and related policies. This new independent body advises the UK Government on setting carbon budgets. Moreover, on 1st December 2008 the committee published its first major report entitled “Building a low-carbon economy – the UK’s contribution to tackling climate change” (Committee on Climate Change 2008). This report recommends that the UK adapts its long-term target to reduce emissions of all greenhouse gases to 80% by 2050. In line with this report, the Government set a target to cut its carbon emission by 33% by 2020.

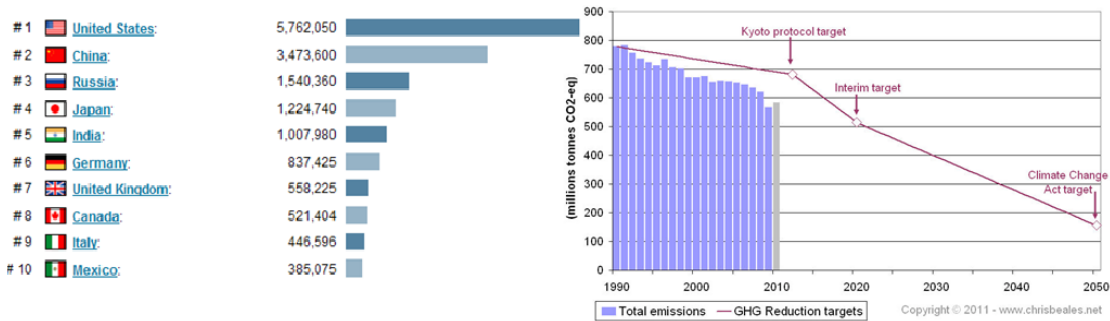

Figure 2: National CO₂ emissions greatest producers in 2011(Nationmaster 2011); UK greenhouse gas emissions compared to targets (DECC 2011e)

3 Generating Energy from Renewable Sources

The UK has had two main drivers for the generation of electricity through renewable energy sources (RES):

- The Non Fossil Fuel Order (NFFO) from 1990 to 1998; and
- The Renewable Obligation (RO) from 2002 to today.

However, it has been proved necessary to add further means for generating renewable energy for smaller scale generators and for the production of renewable heat:

- The Feed-In-Tariff (FIT), April 2010 (HM Government 2008);
- The Renewable Heat Incentive (RHI) (DECC 2011d).

In April 2002, the Renewable Obligation (RO) was introduced in England and Wales. The RO sets an obligation on electricity supply companies to source a steadily increasing amount of their electricity from eligible renewable sources. Each supplier is to provide evidence of compliance with the RO on an annual basis, after the end of each compliance period. Compliance is achieved through the presentation of the required Renewable Obligation Certificates (ROCs). Since 1st April 2002, electricity suppliers have been required by the government to ensure that an increasing proportion of the electricity they sell comes from renewable energy sources. This was set at 4.9% in 2004/5 and will rise annually until it reaches 15% in 2015.

To date (2010) the RO has had limited impact and has been criticised for its lack of effectiveness, largely because it was not designed to reduce risk for investors but instead initiated competition between technologies in an attempts to minimise costs to consumers (G. Wood 2010). Indeed, a renewable generator was originally awarded a ROC for each MWh of electricity generated. Therefore, as all technologies received the same level of support, there was a clear incentive for companies to source the cheapest available power to meet their obligation. In other words, the RO was originally designed to be technology neutral and was designed to run until 2027 (Woodman, Mitchell 2011). However, in April 2009, following the 2007 White Paper on Energy recommendation (HM Government 2007), banding was introduced: established technologies receive fewer ROCs per MWh than emerging technologies. Hence, banding the RO addresses price risk for less developed technologies by attaching more value to a MWh of their generation and thereby incentivising investment. For example, Landfill gas receives 0.25 ROCs/MWh, whereas tidal steam receives 2 ROCs/MWh; existing projects continue to receive 1 ROC/MWh regardless of what technology is being used. Therefore, banding makes the non-mature renewable energy technologies receive a higher level of subsidy, so helping their development. However, it does not reflect different sizes of project, thus it still lets an impetus to concentrate on economies of scale to maximise income.

The reason behind reforming the RO was that the UK Government indicated that leaving the RO unchanged meant that the 2010 (10%), 2015 (15%) and 2020 (proposed 30-35%) targets would not be achieved. Moreover, the UK has already failed to meet RES targets: as shown in Figure 3 the 2009 RES contributed 6.6% of electricity generated against the yearly target of 9.1%. Thus, the NFFO and the RO have for so far not delivered deployment at the expected

level. As RO gives an impetus to concentrate on economies of scale, a Feed-In tariff was introduced in April 2010 for small-scale renewable generation up to 5MW. Indeed, the government acknowledged that smaller scale renewable projects were limited in the extent to which they could benefit from the RO by the high investment risks associated with the mechanism. Under a FIT system, suppliers are under obligation to buy all the output from a project, so removing volume and market risk. In comparison, even under the redesigned RO, generators have no guaranteed market but are instead still required to negotiate a price for their output with electricity suppliers.

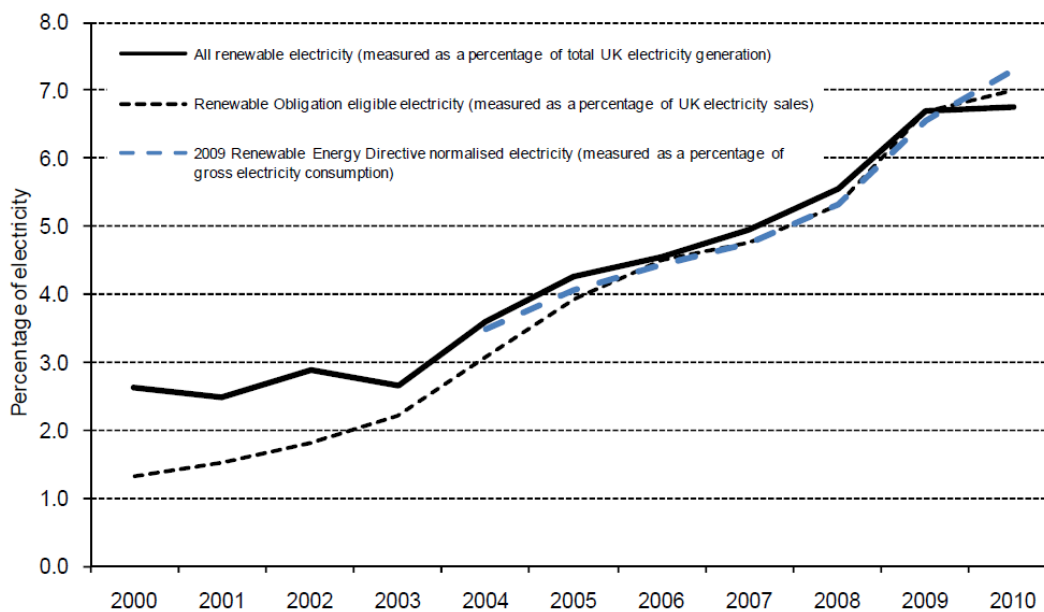

Figure 3: Growth in electricity generation from renewable sources (DECC 2010)

4 Decentralised Energy Financial Analysis

There are different approaches to costing and financing decentralised energy (DE). However, the benefits of any DE technology are only realised through the appropriate operation of the system. The economic benefits of installing a CHP unit on any particular site are achieved when the annual cost savings are sufficient to offer return on the capital invested by the owners of the plant. A large-scale CHP project cannot be evaluated financially in isolation because its capital cost is likely to be sufficiently large to affect the company's overall financial profile. Hence, the company has got to include the CHP's assessment in its overall financial appraisal; the aims of a financial appraisal are (DECC 2011a):

- To determine which investments make best use of the company's funding;
- To guide the optimisation of benefits from each investment opportunity;
- To guide the company's risk management strategies;
- To provide a basis for the subsequent analysis of investment performance.

The capital cost is not a straightforward calculation for a CHP plant. Indeed, a CHP project is not directly process related. Regarding the overall cost savings, the first step is to determine the site's base-load energy demands and the energy costs of meeting this demand over several

time bands without the use of CHP. This also indicates the heat to power ratio of the site during each time band. The second step is to calculate the costs of meeting the same energy demands using the CHP plant selected. The energy cost savings associated with the CHP plant can then be determined. The third step is to include in the analysis:

- A cost estimate for maintaining the CHP plant;
- The installation cost.

4.1 Maintaining the CHP Plant

The incorporation of a CHP unit will include the costs of maintaining the unit, the electrical generator and other associated equipment. Table 1 provides indicative maintenance costs expressed in p/kWh of generated electricity for different technologies operating for 4,500 and 8,000 hours per year.

Table 1: CHP technology indicative maintenance costs (DECC 2011c)

	4500 Operating hours / year	8000 Operating hours / year
Gas turbines	0.4 p/kWh	0.35 p/kWh
Gas engines	0.7 p/kWh	0.6 p/kWh
Dual-fuel compression ignition engines	0.8 p/kWh	0.7 p/kWh
Steam turbines	Less than 0.05 p/kWh	Less than 0.05 p/kWh

4.2 Installation Cost

Most suppliers offer total CHP packages as part of their business: they will provide quotes for installation costs. However, an alternative method of working out an installation cost for financial analysis purposes is to refer to preceding installations of CHP plant costs and to produce a chart from them, such as in Figure 4.

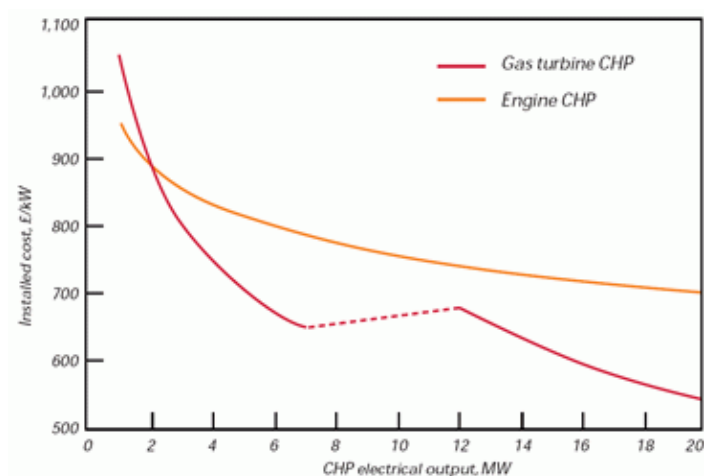

Figure 4: Typical installation costs (DECC 2011b)

4.3 Financial Method

There are two overall approaches to financing CHP units: an “On Balance sheet Approach” and an “Off Balance Sheet Approach”. However, whichever method of financing is chosen, the decision to invest in a large-scale CHP involves a long-term commitment.

On Balance Sheet Approach

A company purchases the CHP unit outright so that it appears as an asset on its balance sheet. Such a capital purchase may deliver maximum benefits, producing the highest NPV, however the initial cash flow will be negative. Finally, a capital purchase is funded using internal funding, external funding or a mixture of both. Another option of On Balance Sheet Approach is to lease a CHP rather than to purchase it.

- **Internal Funding:** With internal funding, the company provides the capital for the CHP unit and for its installation. In doing so, the company retains full ownership of the project and reaps the maximum potential benefits. However, while investing in a CHP plant, the company bears a considerable amount of technical and financial risk.
- **External Funding:** A large capital purchase is often funded by a combination of external and internal funding; External finance generates some depth for the company. As with full internal financing, the residual technical and financing risks remain with the company; at the same time, the company retains the full benefits of the installation.
- **Leasing:** Leasing is a financial arrangement that allows a company to use an asset over a fixed period. For the asset to remain on balance sheet, the lease will be a finance lease (as opposed to an operating lease) whereby the lessee retains full risks of ownership.

Off Balance Sheet Approach

This financing option is particularly attractive for companies that cannot provide the funds for the capital purchase of their CHP unit. Although this approach avoids the upfront cash outflow, the NPV tends to be lower than for the capital purchase option. In the United Kingdom, two types of organisation can arrange or supply off balance sheet financing for CHP plant:

- **Equipment Supply Organisations** offer a leasing package to the company. They pay all the costs of design, installation, maintenance and operation and thereby retain most of the technical risk associated with the system. The operating company pays for the fuel and contracts to buy the electricity and the heat generated from the CHP engine at an agreed price. Generally, the operating company’s financial savings will be significantly lower under this arrangement than under a capital purchase arrangement, and they will also retain the risks relating to fuel price fluctuations.
- **Energy Services Company (ESCO)** arrangements can vary greatly. In all arrangements, the ESCo supplies heat and power to the company at agreed rates. The ESCo may also take responsibility for fuel purchase and for other on-site energy plant. In some cases, it will size the CHP plant to meet the heat requirement of the company and produce surplus electricity that can be exported and sold. In this case, the operating company will only receive part of the overall value of the energy savings,

but as these overall savings are greater than the savings that would have been achieved under a smaller capital purchase scheme, the company's share may still have a greater value. Moreover, an ESCo can adapt the proposal depending on the operating company's requirements and its objective. Although an ESCo may not finance the entire energy system / CHP unit (unlike an equipment supplier) it will bring some investment to the project, the scale of this investment being dependent upon the savings and revenues that the energy centre can achieve. Below is a list of the principle variables to be resolved:

- Who will operate the plant on a day-to-day basis and therefore, bear the performance risk?
- Who will maintain the plant?
- Who will own the plant at the end of the initial agreement period (typically 10-15 years)?

4.4 Economic factors

The viability of a CHP plant is not only dependent on its size and its good operation, but also on economic factors including:

- fuel prices,
- electricity prices,
- taxes, and
- prices for other heating alternatives.

Economic profitability improves if (Reidhav, Werner 2008):

- Market conditions allow for a competitive DE heat and electricity price;
- Low marginal heat generation costs;
- Low service and maintenance costs;
- Low demands on rate of return from the owners.

The economics of CHP plants depend greatly on taxation levels with high consumption taxes on oil, natural gas and electricity working to the benefit of CHP as they generate both heat and electricity efficiently.

5 Case Study: A Hotel in Central London

This Hotel is a steel structure building and opened its doors in 1909. With 785 guest rooms, it is a 31,000m² building located in central London; it accommodated 317,000 guests in 2010. There is at present no air conditioning in the guest rooms of the hotel, but this is available in the 'public' spaces. The hotel was awarded "Silver" under the Green Tourism for London scheme in 2010 and is aiming to achieve "Gold" for 2011. Indeed, the Chief Engineer is passionate about system performance and has a good relationship with their CHP supplier.

The energy plant is located in the basement of the hotel and includes two CHP engines of 250kWe and three 500kW boilers. The electrical base load of the hotel is 800kWe. The electrical output from the CHP engines replaces some grid electricity and the heat output

replaces the use of gas boilers. These CHP engines operate 24/7 during the winter months at approximately full rate; in the summer months, as no thermal tank is included in the plant, the CHP engines are turned off to avoid dumping any heat.

5.1 Commercial terms

The CHP engines are leased from a supplier over a 12 year term and as such are ‘off balance sheet’ for the hotel. The hotel pays a unit price per kWh of electricity generated, set by the supplier to cover all maintenance costs and to give them an effective return on capital:

- 4p/kWhe day rate
- 1.39p/kWh night rate

It is understood that, as the Chief engineer has a good relationship with the supplier, slightly non-standard terms have been agreed whereby the amount paid by the hotel is effectively fixed each month based on a monthly day rate output of 1,000MWh regardless of actual output. Thus when the hotel runs the engines 24/7 during winter months any output above 1,000MWhs is effectively ‘free’. This is offset by the summer months when the engines are turned off. On this basis, the actual amount paid to the equipment supplier in 2010 was of the order of £91k. From the hotel’s point of view, this represents their maintenance and financing costs of the plant. All fuel (for the CHP engines and the heat only boilers) is purchased directly by the hotel.

5.2 Financial and environmental analysis

The left hand figure below gives the monthly heating produced by the CHP units and the heat only boilers. The combined total is equivalent to the total hotel heat demand. The right hand figure gives the monthly electricity generated by the CHP units and that imported from the grid (at low rate - night tariff, and normal rate – day tariff). The combined total is the total hotel electricity demand. Table 2 gives the annual heating and electricity generation from every energy unit and the grid electricity imported. This study compares the operation of the hotel’s energy plant with a baseline corresponding to the case when the hotel is assumed to be heated with natural gas boilers and the electricity is taken from the grid. The natural gas boilers have been assumed to operate with a seasonal efficiency of 85% (CIBSE 1998).

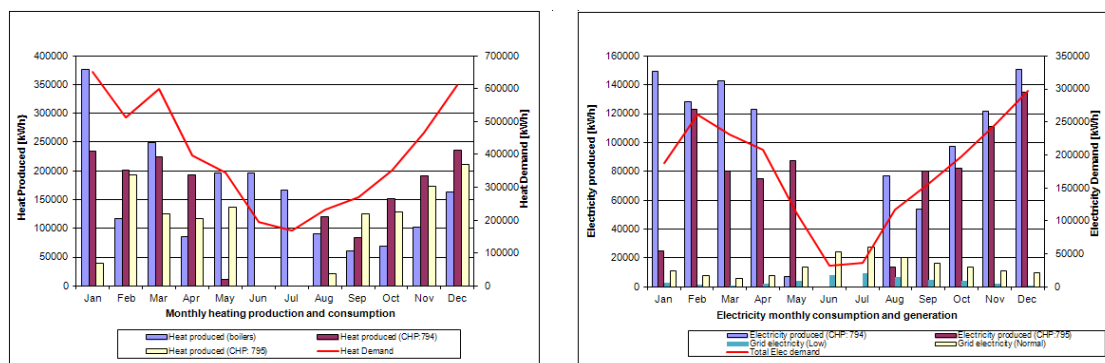

Figure 5: Hotel's heat and electricity monthly consumption

5.3 Carbon analysis

To calculate CO₂ savings, carbon factors used are taken from The Government's Standard Assessment Procedure for Energy Rating of Dwellings (DECC 2009b):

- Natural gas: 0.198 kg CO₂/kWh;
- Grid electricity: 0.517 kg CO₂/kWh.

Multiplying the carbon factor by the annual heat and electricity consumed from the hotel, the hotel's baseline emission would be:

- Heat: $4796546 * (0.198/0.85) = 1,117,313$ [kg CO₂/kWh]
- Electricity: $2081485 * 0.517 = 1,076,128$ [kg CO₂/kWh]
- Total CO₂ emissions: 2,193,441 [kg CO₂/kWh]

The total CO₂ emission from the actual operation of the hotel, as given in Table 2, is of 1,758 tonnes CO₂/kWh. Hence, the incorporation of the CHP engines in the energy plant contributed to 20% CO₂ reduction in 2010.

Table 2: Heat produced and electricity consumed from the hotel in 2010

	Heat produce kWh/year	Electricity produced or imported kWh/year	CO2 emission - hotel kg CO2/year
Boilers	1874087	--	436552.0737
CHP: 794	1647784	1050967	681498.7078
CHP: 795	1274675	812996	527186.6038
Grid electricity (Low)	--	48243	24941.631
Grid electricity (Normal)	--	169279	87517.243
Total	4796546	2081485	1757696.259

5.4 Financial analysis

Figure 6 shows the actual monthly cost of operating the hotel energy plant with its CHP engines during 2010 compared with the baseline equivalent. Actual costs comprise payments to the equipment supplier as described above, fuel costs and the costs of grid electricity imported to meet total demand. Baseline costs have been calculated using the actual electricity and gas unit prices as applied to total gas and electricity demand. As described above, the gas use is calculated using heat demand and an assumed efficiency of a heat only boiler of 85%.

One difference between unit rates for gas between the CHP and baseline scenarios relates to the Climate Change Levy (CCL), an environmental energy tax. The CCL is payable by non-domestic energy consumers per unit of energy purchased. For gas, the rate in 2010 was 0.01791 £/kWh. A qualifying CHP plant is exempt from paying this tax on gas purchases. In the case of this hotel, the effect was an approximate 95% reduction in CCL paid. Figure 6

shows clearly that when the CHP is operating fully during the winter months, the total cost of running the plant, including payments to the equipment supplier (red / pink) are less than would be payable under the baseline scenario (blue). However, in summer months, the costs of the CHP unit are greater.

Over the whole year, summing the monthly savings or losses, the cost of running the CHP engines was slightly more (£564) than the cost of running only gas boilers and importing all energy from the grid. Considering energy costs alone however (i.e. excluding payments to the equipment supplier) the costs of running the CHP engines would have been considerably less, therefore yielding greater savings: if an allowance is made for maintenance cost that would have to be paid (approximately £13k based on an indicative value of 0.7p/kWh given in Table 1), the value of these savings would have been ~£77k. These savings are magnified by the differential between gas and electricity prices. Until September 2010 the hotel was purchasing gas and top-up electricity under fixed price contracts. When these contracts ceased, the cost of electricity increased significantly while gas stayed roughly the same. The savings in October-December thus increased due to the value of grid electricity being displaced.

The analysis highlights the importance of the financing structure for realising the efficiency benefits of CHP. In this case study, the supplier is the owner of the CHP engine and receives £91k per year. Based on an installed capital cost of two 250kWe CHP engines of £420,000 and maintenance costs of 0.7p/kWh per year (Table 1), payback for the equipment supplier will be approximately 4 years. This contrasts with the breakeven position of the hotel as the energy user.

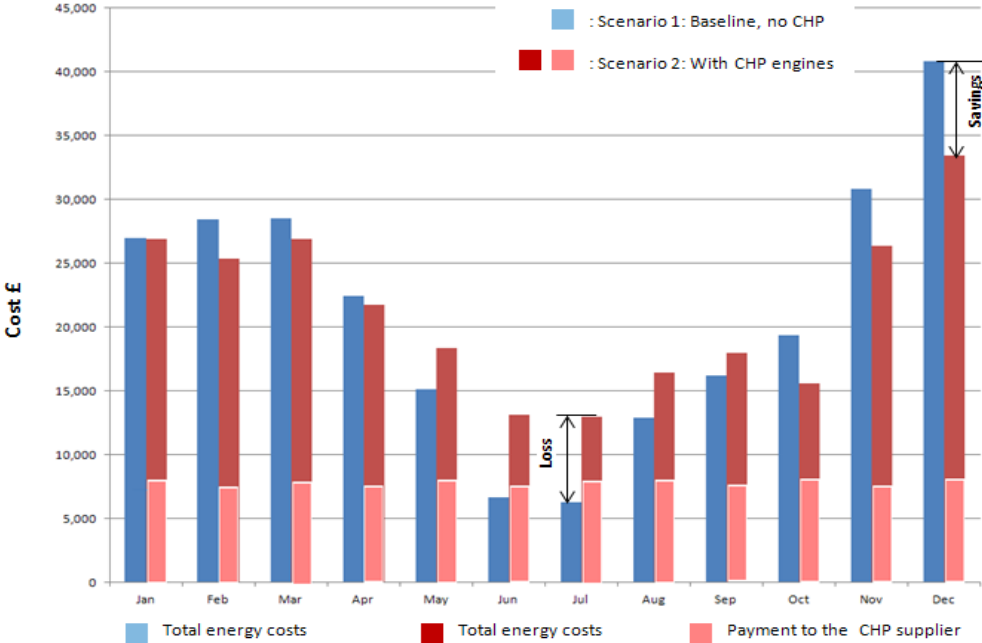

Figure 6: Financial operation of the hotel's energy plant compared to the baseline

6 Conclusion

In response to the threat posed by climate change, the Government intention is to decarbonise the economy. It seeks to achieve this through carbon reduction targets and incentivises for

investment in renewable energy (RE). In this context, a natural gas fired CHP engine can help towards decarbonising the economy in the near term by generating heat and electricity more efficiently and at a local level. In the longer term as the grid decarbonises, the carbon impact of a natural gas fired CHP engine will reduce; however there is significant potential to introduce alternative technologies and renewable fuels. Furthermore, if the natural gas engine to be replaced is connected to a DH network, no disruption to the end consumers will be caused.

This study has investigated the environmental and financial implications of using a DE system in the UK in the current conditions. A technology generating both heat and electricity, a CHP engine, has been selected to better identify the economic and technical implications linked to DE. It has been demonstrated that incorporating a CHP engine within a building is not trivial. However, the financial and environmental performance of a natural gas fired CHP engine in the UK has been validated: a natural gas fired CHP engine can reduce the operating cost of an energy plant and as long as grid electricity includes a small percentage of renewable sources or nuclear energy, the CO₂ emissions are also reduced. It has been shown that, in the absence of a heat store or alternative use of surplus heat, the operation of the CHP engine varies greatly between winter when the engine is beneficial and summer when the CHP engine may be oversized. In a further study the incorporation of an absorption chiller will be analysed to assess its viability while guaranteeing the good functioning of the CHP engine in the summer months. Finally, this case study has also shown that the financing structure of a DE system is important in terms of which entity realises the benefits of more efficient generation.

References

- Bøhm, B., Ha, S., Kim, W., Kim, B., Koljonen, T., Larsen, H.V., Lucht, M., Park, Y., Sipilä, K., Wigbels, M. & Wistbacka, M. 2002, Simple Models for Operational Optimisation, IEA, Paris.
- CIBSE 1998, Energy efficiency in buildings - CIBSE Guide F, Crown, London.
- Committee on Climate Change 2008, Building a low-carbon economy - the UK's contribution to tackling climate change, Crown, London.
- DECC 2011a, 01/04/2011-last update, Finance - Appraisal [Homepage of DECC], [Online]. Available: <http://chp.decc.gov.uk/cms/appraisal-2/> [2012, 01/26].
- DECC 2011b, 01/04/2011-last update, Finance - Installed Cost [Homepage of DECC], [Online]. Available: <http://chp.decc.gov.uk/cms/installed-cost/> [2012, 01/26].
- DECC 2011c, 01/04/2011-last update, Maintenance Costs [Homepage of DECC], [Online]. Available: <http://chp.decc.gov.uk/cms/maintenance-costs/> [2012, 01/26].
- DECC 2011d, Renewable Heat Incentive, DECC, London.
- DECC 2011e, UK Climate Change Sustainable Development indicator: 2010 Greenhouse Gas Emissions, Final Figures by Fuel Type and End-Users, DECC, London.
- DECC 2010, Renewable energy in 2010, DECC, London.
- DECC 2009a, Climate Change Act 2008 Impact Assessment, DEFRA, London.
- DECC 2009b, The Government's standard Assessment Procedure for Energy Rating of Dwellings, BRE, Garston, watford WD25 9XX.
- DEFRA 2003, Our energy future - creating a low carbon economy, DTI, London.
- G. Wood, S.D. 2010, "What lessons have been learned in reforming the Renewables Obligation? An analysis of internal and external failures in UK renewable energy policy", .

HM Government 2009, The UK Low Carbon Transition Plan, National strategy for climate and energy, London.

HM Government 2008, Energy Act 2008 - Chapter 32, Secretary of State, London.

HM Government 2007, Meeting the Energy Challenge, A White Paper on Energy, May 2007, Crown, London.

HM Government 2006, The Energy Challenge, DTI, London.

Nationmaster 2011, , CO₂ emission statistics - countries compared worldwide [Homepage of Nationmaster online], [Online]. Available: http://www.nationmaster.com/graph/env_co2_emi-environment-co2-emissions [2012, January 26th].

Reidhav, C. & Werner, S. 2008, "Profitability of sparse district heating", Applied Energy, vol. 85, no. 9, pp. 867-877.

Woodman, B. & Mitchell, C. 2011, "Learning from experience? The development of the Renewables Obligation in England and Wales 2002–2010", Energy Policy, vol. 39, no. 7, pp. 3914-3921.

APPENDIX C CURRENT AND FUTURE OPERATION SCENARIOS FOR A 50,000 MWH DISTRICT HEATING SYSTEM (PAPER 3)

Full Reference

Martin-Du Pan, O., Eames, P., Rowley, P., Bouchlaghem, D., Susman, G., 2014. Current and future operation scenarios for a 50,000 MWh district heating system. Architectural engineering and design management. Published online (30 Mar 2014): <http://dx.doi.org/10.1080/17452007.2014.899889>.

Abstract

The performance of Pimlico District Heating Undertaking (PDHU), in London, with an annual heating load of 50,000 MWh was analysed throughout 2012. Half hourly data for the system was investigated to determine the natural gas consumed, operation of the 2,500 m³ accumulator, the two 1.6 MWe CHP engines, the three 8MW boilers, the electricity import and export and the consumers' heat consumption. This data was used to characterise the current performance in detail and an energy flow diagram for the system energy flows was generated. The modulating efficiencies of the boilers varied from 84% to 91% whereas the CHP engines performed with a modulating near constant electrical efficiency of 40%, but with a thermal efficiency that decreases with higher load. The current operation of the plant is compared across ten scenarios. These scenarios were compared while (i) using the accumulator more effectively to let the boilers operate at full load only and (ii) using the provided maintenance agreement contract of the CHP engines to guarantee their good operation. Optimising the operation of the current plant reduces the annual heating cost of £165,000 or 12% and investing in additional CHP capacity can reduce the CO₂ emissions of 28%.

Nomenclature

CO_2	CO ₂ emission of the energy plant (Tonnes CO ₂ /year)
$CO_{2_equivalent}$	CO ₂ equivalent of the energy plant (Tonnes CO ₂ /year)
C_p	specific heat capacity (kJ/kg/K)
F_{Heat_loss}	heat loss factor (-)
I	current (A)
$Q_{Accum_Heat_loss}$	heat stored or discharged from the accumulator (MWh)
Q_{Boiler_i}	heat generated by a boiler (MWh)
Q_{CHP_i}	heat generated by a CHP engine (MWh)
$Q_{Charged}$	heat charged to the accumulator (MWh)
$Q_{Consumed}$	heat consumed (MWh)
$Q_{conversion}$	conversion loss (MWh)

$Q_{DHN_Heat_loss}$	heat loss from the total DHN (MWh)
$Q_{Discharged}$	heat discharged from the accumulator (MWh)
$Q_{Generated_heat}$	heat generated (MWh)
$Q_{Natural_gas}$	natural gas thermal energy (MWh)
$Q_{Zone1_Consumed}$	heat consumed in Zone 1 (MWh)
$Q_{Zone1_Heat_loss}$	heat loss to the soil in Zone 1 (MWh)
$Q_{Zone1_Supplied}$	heat supplied to Zone 1 (MWh)
$\dot{Q}_{Zone1_Supplied}$	rate of heat supplied to Zone1 (MW)
$Q_{Zone1_30min_Cons}$	zone 1 aggregated heat consumption over a 30 minute interval (MWh)
$Length_{Zone1}$	length of zone 1 DHN (m)
n_{per}	the total number of payments for the loan
n	Time
n_{per}	the total number of payments for the loan
Pv	the present value
$rate$	the interest rate for the loan
V	voltage (V)
$W_{All_Energy_units}$	electricity consumption by the boilers and CHP engines (MWh)
$\dot{W}_{All_Energy_units}$	rate of electricity consumption by the boilers and CHP engines (MW)
\dot{W}_{Boiler_i}	rate of electricity consumption by boiler i (MW)
W_{Energy_Centre}	total electricity consumption by the energy centre (MWh)
$\dot{W}_{Energy_unit_i}$	rate of electricity consumption by energy unit i: A boiler or a CHP engine (MW)
$\dot{W}_{Energy_unit_i_Cooling}$	rate of electricity consumption to pump the cooling water to the energy unit i: A boiler or a CHP engine (MW)
$\dot{W}_{Energy_unit_i_Operation}$	rate of electricity consumption for the operation of energy unit i: A boiler or a CHP engine (MW)
$W_{generated}$	electricity generated from the CHP engines (MWh)
W_{Ind_boiler}	Parasitic electricity consumed by the individual boiler (MWh)
$W_{Network}$	electricity consumption by the DHN pumps (MWh)
$\dot{W}_{Network}$	rate of electricity consumption by the DHN pumps (MW)
\dot{W}_{Total}	rate of electricity consumption by the energy plant (MW)

Symbols

ΔT	Difference in temperature (°C)
η_{th}	Boilers or CHP engines energy efficiency (%)
$\eta_{Ind.Boiler}$	Individual boiler efficiency (%)

Glossary

DH	District heating
DHN	District heating network
CHP	Combined heat and power
DHW	Domestic hot water
SH	Space heating
RE	Renewable energy
HHV	High heating value

1 Introduction

District heating (DH) is a mature technology. It has been studied extensively in several countries including Denmark, Germany and Sweden. Previous research has focused on the analysis of DH financial viability [1, 2, 3, 4], the effect of demand side management (DSM) with respect to energy generation [5, 6] and optimisation of a district heat network (DHN) in sparse areas [7, 8, 9]. However, in the literature surveyed, no research looked at quantifying in an existing DH system the financial balance of the energy centre (EC) and the operational CO₂ emissions. This paper presents such an analysis for PDHU in London.

In order to meet the current energy demands of London's homes, business and infrastructure through the provision of an efficient, affordable and secure supply of low and zero carbon energy, the Mayor of London plans to deliver 25% of London's energy needs through decentralised systems by 2025 [10, 11]. However, this needs to be achieved while guaranteeing affordability and energy security [12]. By 2050, the UK aims to reduce its CO₂ emission by 80%; to achieve this, heating will have to become almost zero carbon.

To supply heat and electricity to large residential estates that were devastated during the Second World War, municipal energy services became very popular in the United Kingdom [13]. A large housing estate, Churchill Gardens in the Pimlico area of Westminster in London, installed a district heating system that became operational in 1950. This district heating system was at this time a rare example of this technology in the UK and Europe. The system had the additional benefit of reducing the smog in this area of London; heat was used from the now-disused Battersea's combined heat and power (CHP) power station built on the opposite side of the Thames. It provided space heating (SH) and domestic hot water (DHW) until 1983 throughout Churchill Gardens. Battersea Power station's heat was pumped through a buried pipe under the river Thames and stored in a glass-faced accumulator of 2,500m³ in Churchill Gardens to provide short term thermal storage. This accumulator operated as a thermal buffer and stored heat to meet the consumers heating demand which was pumped when required through the DHN. The energy centre at PDHU inherited its name after this activity: "The Pump House".

Today, PDHU generates its heat and electricity from a new energy centre which incorporates both gas fired CHP engines and boilers. It distributes approximately 50 GWh/yr of heat through a 7,900 m DHN to 3,256 residential properties and 55 commercial properties. This corresponds to an annual line heat density of approximately 6.5 MWh/(yr·m).

This paper describes how PDHU currently operates and analyses the efficiency of each energy unit in terms of heat and/or electricity generated, natural gas and supplementary electricity consumed to achieve good combustion and to pump the “cooling” water through each energy unit. It also assessed the heat losses to the soil from the DHN; several authors have identified this as a significant issue [8, 14, 15]. The district heating system is analysed holistically to firstly determine how much heat and power is generated and consumed to operate each energy unit and to run their pumps and secondly to assess the power consumption to pump the DH water to each consumer. The CO₂ emissions associated with the DH system are then investigated and a range of system options are analysed and compared with corresponding performance in terms of financial, energy and CO₂ emissions [16]. Finally, this analysis informs prioritisation of any future interventions to be made at this site to minimise future operation cost.

2 Method

2.1 System description

As shown in Fig. 1, PDHU consumers are located in three different areas: Churchill Gardens, Abbots Manor and Lillington & Longmoore. Churchill Gardens account for approximately 60% of the systems heat load and its heat is taken from a header that divides Churchill Gardens into five zones, see Fig. 2. A schematic of PDHU energy plant is given in Fig. 3 and shows that the heat is generated by two 1.6MWe CHP engines and three 8MWth boilers. The energy centre also includes a thermal accumulator that helps to balance the heat generated and heat loads on the system.

In Zone 1, indicated in Fig. 1 and 3, the consumers are connected directly to the DHN for space heating and DHW at 55°C is generated, as indicated in Fig. 4, at the consumer with the use of a calorifier. An on-site calorifier undergoing maintenance is shown in Fig. 2.

2.2 Current system operation

2.2.1 Consumed Heat

The consumed heat is generated from the boilers and the CHP engines within the energy centre and is calculated using Eq. (1), which also includes the heat losses from the accumulator and to the soil. The heat generated data are logged data, whereas the accumulator and DHN heat losses are calculated data.

$$Q_{Consumed} = Q_{Boiler_1} + Q_{Boiler_2} + Q_{Boiler_3} + Q_{CHP_1} + Q_{CHP_2} - Q_{Accum_Heat_loss} - Q_{DHN_Heat_Loss} \quad (1)$$

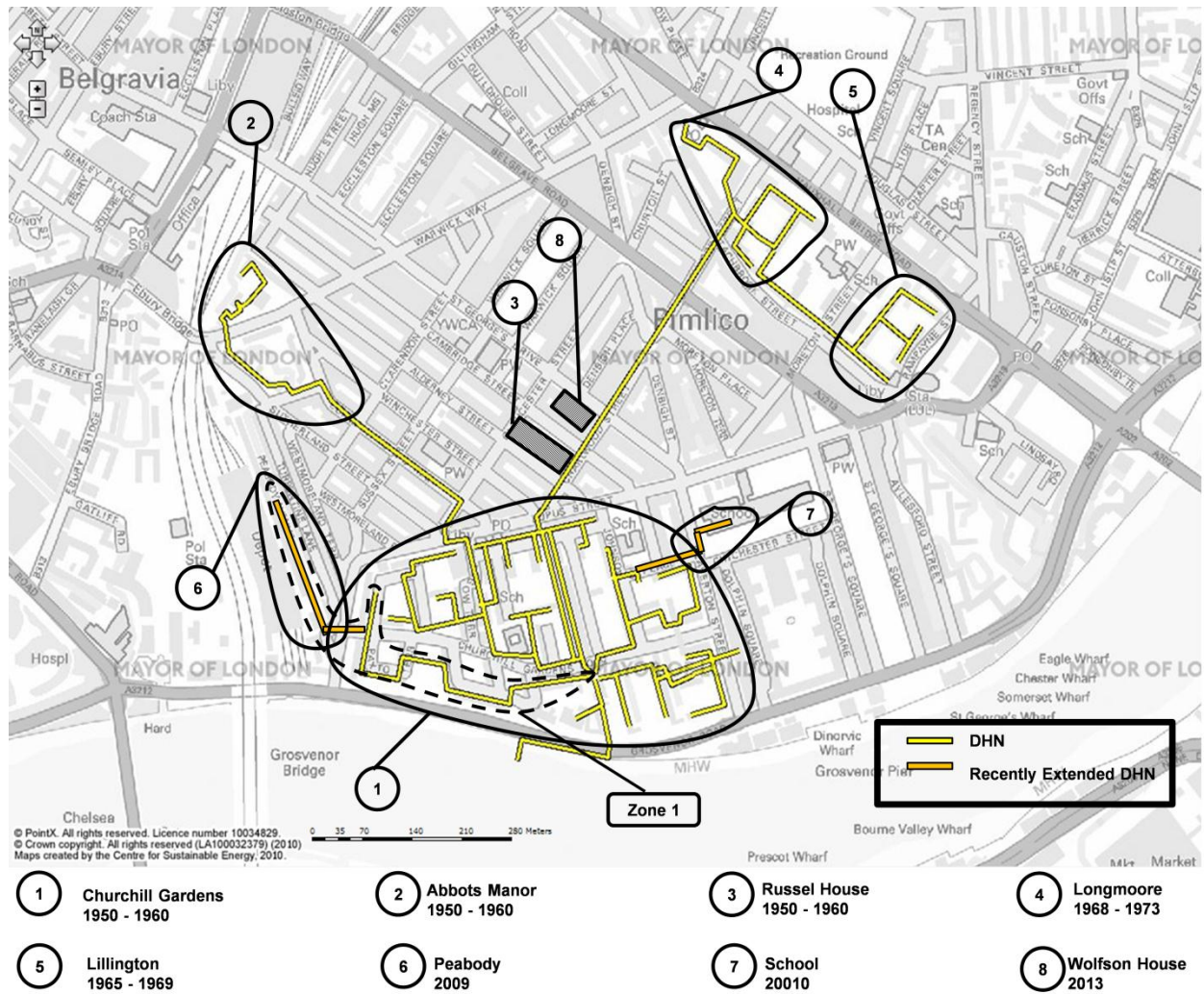

Figure 1 PDHU DHN

2.2.2 Boiler and CHP engine conversion losses

Data on the operation of PDHU is compiled by a company called Schneider [27]. With permission, access to this data was granted. Hence, the natural gas conversion into heat and electricity is known throughout the year on a half hourly basis for every CHP engine and boiler. Eq. (2) can be used to calculate the conversion losses.

$$Q_{conversion} = Q_{Natural_gas} - Q_{Generated_heat} \quad (2)$$

2.2.3 Accumulator heat loss

As the heat stored and discharged from the accumulator was measured on a half hourly-basis, a seasonal heat loss can be calculated using the following equation:

$$Q_{Accum_Heat_loss} = \sum_{1-n} Q_{Charg ed} - \sum_{1-n} Q_{Discharg ed} \quad (3)$$

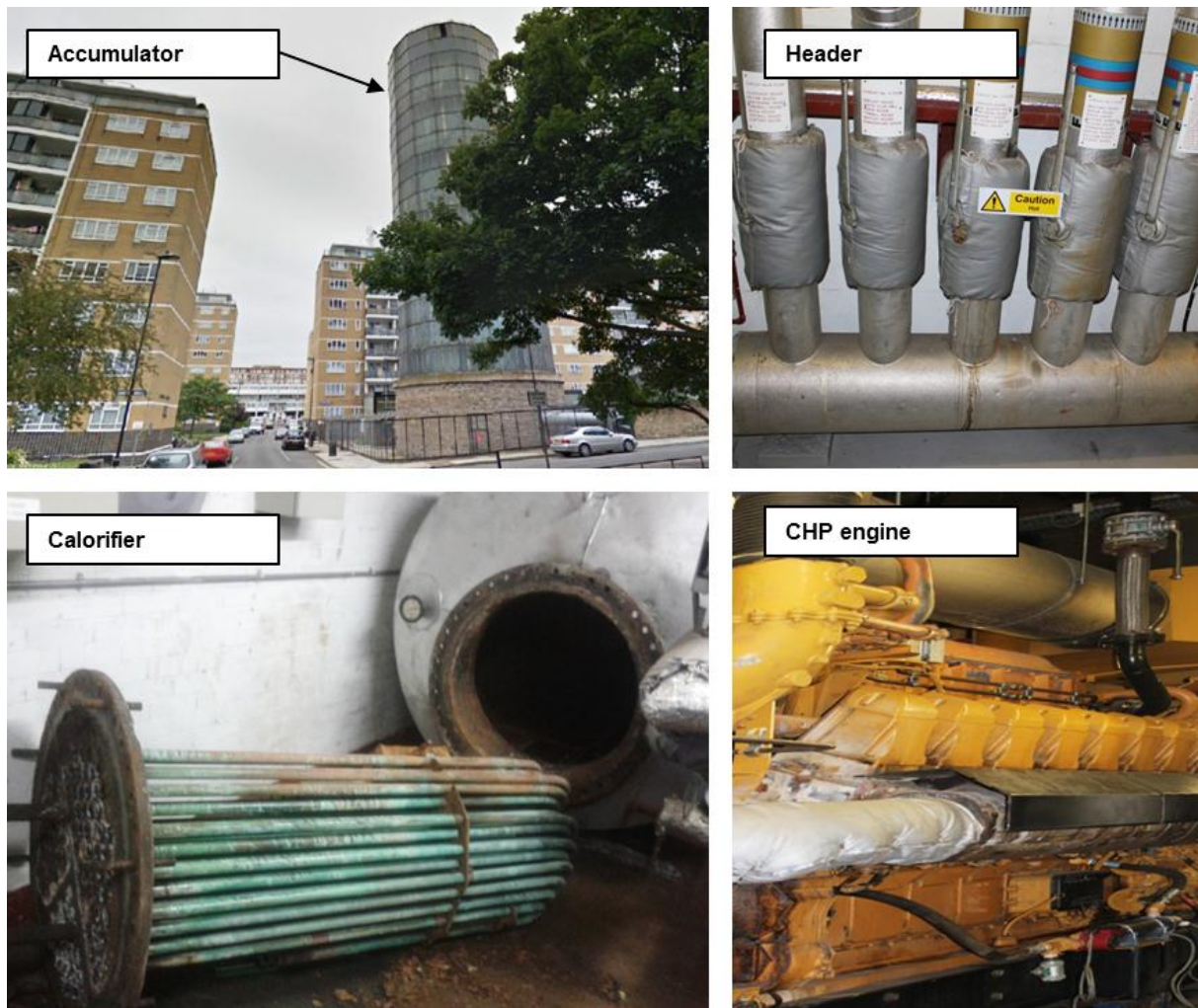

Figure 2 Element of the DH scheme. Tower block with residences served by the visible accumulator (top left), header with flow to five zones in Churchill Gardens (top right), a calorifier under maintenance with its exposed “U” bend tubular heat exchangers (bottom left) and a 1.6 MWe CHP engine (bottom right).

2.2.4 Heat loss to the soil

Heat is pumped through an underground network to the consumers which results in some heat loss to the soil. It was assumed that the heat loss rate to the soil from the network is constant throughout the DHN and the year. Thus, after using Zone 1’s heat loss to the soil calculated with Eq. (4) on the 27th of November from 0:00 to 23:55, an annual heat loss factor per meter of DHN was calculated using Eq. (5) and the actual length of Zone 1 DHN of 552 m (see Fig.1). This calculation assumed that (i) the soil temperature is constant throughout the year (12°C) [17] and that (ii) the supply temperature was continuously equal to its average supply temperature of 83°C.

$$Q_{Zone_Heat_loss} = \sum_{i=1}^{48} Q_{Zone_Supplied} - \sum_{i=1}^{48} Q_{Zone_Consumed} \quad (4)$$

$$F_{Heat_loss} = \frac{365 * Q_{Zone_Heat_loss}}{Length_{Zone}} \quad (5)$$

The daily heat supplied to Zone 1 used in Eq. (4) was calculated using Eq. (6) over a 24 hour period. The instantaneous power-heat supply is obtained from Eq. (7) calculated at 5 minute intervals, requiring knowledge of the instantaneous flow rate and supply and return water temperature to this leg of the network. An ultra-sonic flow meter [18] was used to monitor the instantaneous flow rate of the water supplied at the start of the leg where the pipe is of 150 mm internal diameter. Simultaneously, the external surface of both steel pipes supplying and returning water from Zone 1 was monitored with thermocouples [19] and assumed to be similar to the water temperature circulating through it.

$$Q_{Zone_Supplied} = \frac{5}{12} * \sum_{i=1}^{288} \dot{Q}_{Zone_Supplied}(n), DT = 5 \text{ minutes} \quad (6)$$

$$\dot{Q}_{Zone_Supplied}(n) = \dot{m} C_p \Delta T \quad (7)$$

The daily heat consumed from Zone1 used in Eq. (4) was calculated using Eq. (8) which is the sum of the half hourly aggregated heat consumption for the ten buildings connected to this leg from Zone 1 over a 24 hour period. Out of this sample of buildings, Ripley House was the only building not connected to the Schneider data logging system which logs the heat consumption of the 9 other buildings in this zone on 30 minute intervals. However, as Ripley House is a reproduction of Sheraton House (a building that is also connected to this leg), Ripley House was assumed to behave similarly to Sheraton House and to have a similar dynamic heat consumption.

$$Q_{Zone_Consumed} = \sum_{i=1}^{48} Q_{Zone_30min_Cons}(n), DT = 30 \text{ minutes} \quad (8)$$

Figure

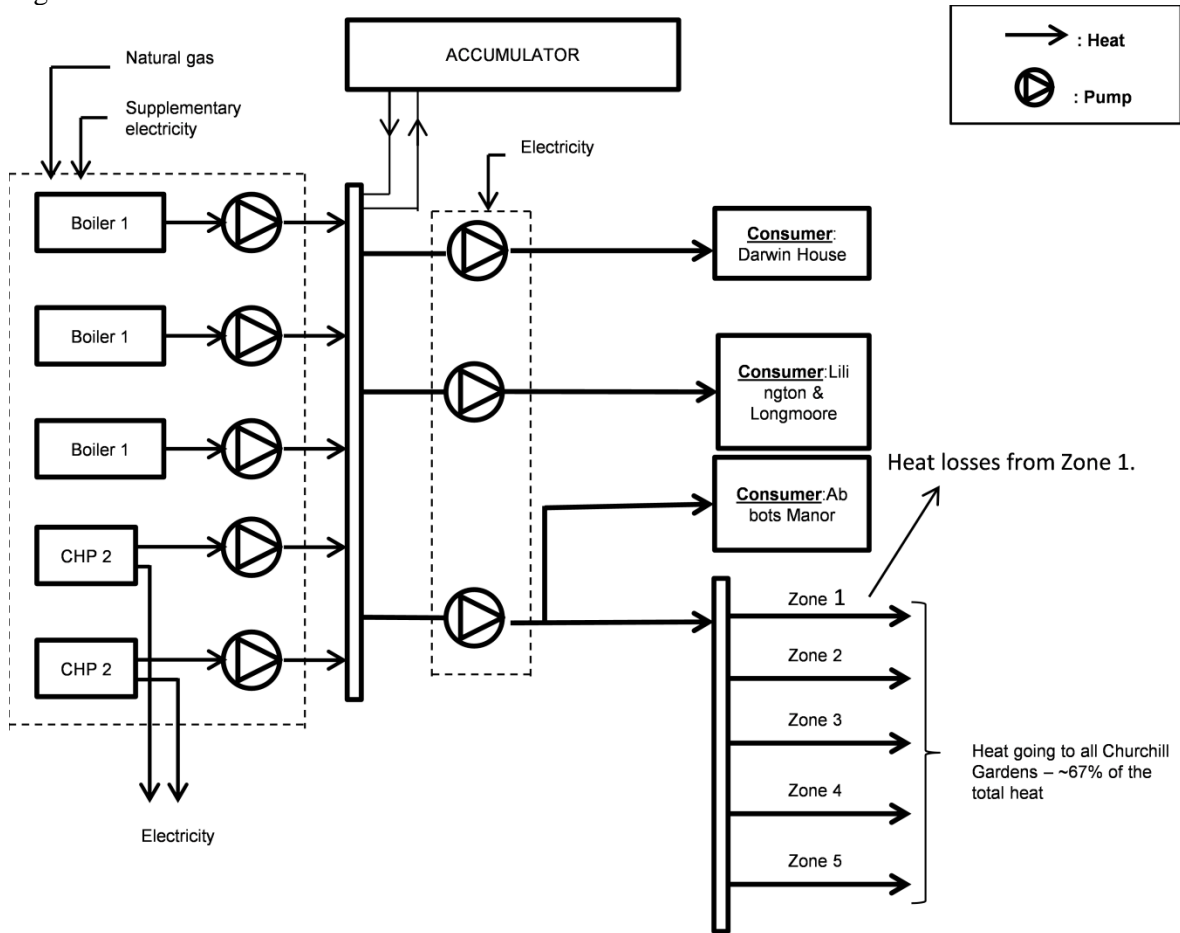

Figure 3 Schematic of PDHU's energy unit

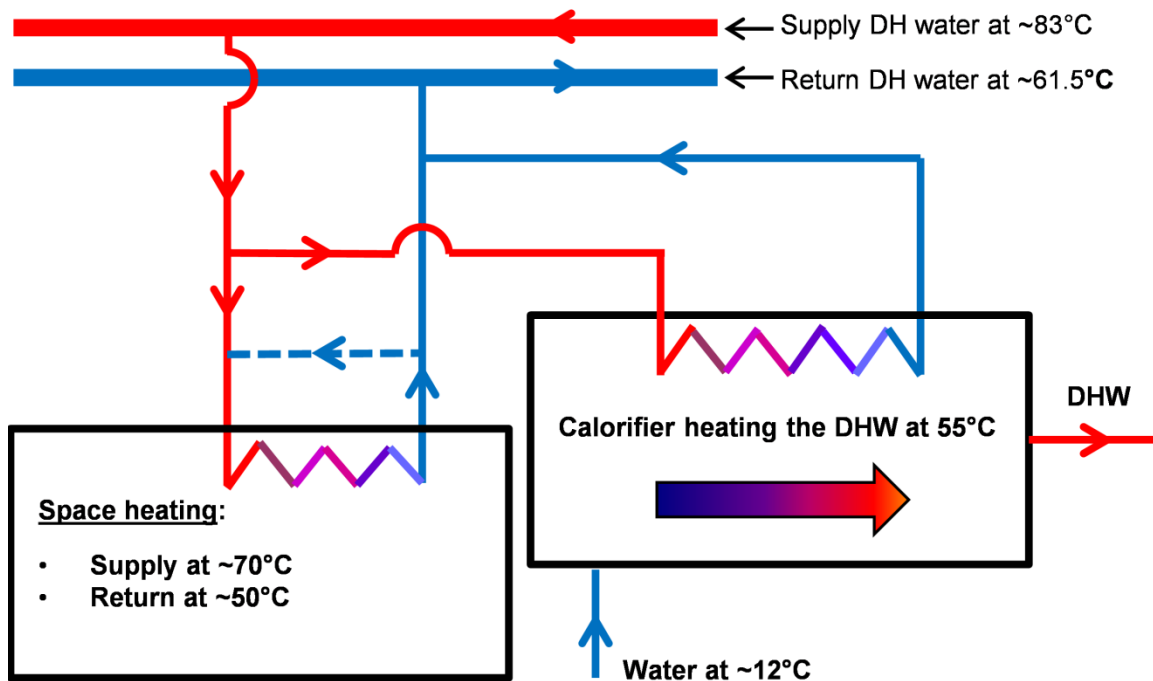

Figure 4 DH connections at the consumers in Churchill Gardens

2.2.5 Electricity consumption and generation

As the electricity export data logged to the Schneider website was incomplete due to a failure of the exported data, no useful estimation of the total electricity consumption from the energy centre was obtained while the CHP engines were operating. Hence, in order to assess the total electricity consumption while the CHP engines were operating, the total electricity consumption was calculated using Eq. (9) which isolates the power consumption to operate the boilers and the CHP engines from the power consumption to supply the heat to the DHN.

$$W_{Energy_Centre} = W_{All_Energy_units} + W_{Network} \quad (9)$$

2.2.5.1 Annual power consumption to pump the DHN water: $W_{Network_Annual}$

The annual electricity consumed to pump the DHN water was calculated using an interpolation curve that links the power consumption to supply a known amount of heat. This power consumption was calculated on a half-hourly basis through the year. Eq. (10) calculates the annual energy-power consumption to supply the heat to the DHN. This equation converts the half hourly data calculated in MW to a value in MWh, by assuming that the calculated values remain constant during each 30 minute interval.

$$W_{Network} = \frac{1}{2} \sum_{i=1}^{17520} \dot{W}_{Network}(n) \quad (10)$$

2.2.5.2 Boiler and CHP engine annual power consumption: $W_{En_unit_Annual}$

Using the calculated instantaneous power consumption throughout the year from every boiler and CHP engine, Eq. (11) calculates the respective annual electric energy consumption in MWh by assuming that the calculated instantaneous power consumption remains constant during each 30 minute interval.

$$W_{All_Energy_units} = \frac{1}{2} \sum_{i=1}^{17520} \dot{W}_{All_Energy_units}(n) \quad (11)$$

2.2.5.3 Power to operate the DHN pumps: $\dot{W}_{Network}$

As export electricity data was incomplete, the data to draw the interpolation curve for the power consumption to pump the heat through the DHN was selected for the time when no CHP engines were operating. This power consumed was calculated using Eq. (12) that subtracts the total electricity consumption of the plant with the power consumption of every boiler.

$$\dot{W}_{Network}(n) = \dot{W}_{Total}(n) - \dot{W}_{Boiler_1}(n) - \dot{W}_{Boiler_2}(n) - \dot{W}_{Boiler_3}(n) \quad (12)$$

2.2.5.4 Power to operate and cool the boilers and the CHP engines: $\dot{W}_{All_Energyunits}$

For both gas fired energy units, the power consumption was separated into two categories. Firstly, the power to activate a shunt pump to circulate the cooling DH water. Secondly, the power to activate the energy unit itself: the burners for the boilers and the engine's cylinders with the circulation of their engine oil for the CHP engines. With this data, two interpolation curves predicting the power consumption of both energy units while operating at different loads were established.

As the boilers and the CHP engines were assumed to operate in quasi-steady state condition, their supplementary electricity consumption is only dependent on their natural gas consumption. Eq. (13) calculates their respective total supplementary electric power consumption during operation.

$$\dot{W}_{Energy_unit_i}(n) = \dot{W}_{Energy_unit_i_Operation}(n) + \dot{W}_{Energy_unit_i_Cooling}(n) \quad (13)$$

Finally, Eq. (14) was used to calculate the total power consumed from every boiler and CHP engine at a specified time throughout the year.

$$\dot{W}_{All_Energy_units}(n) = \dot{W}_{Energy_unit_1}(n) + \dots + \dot{W}_{Energy_unit_5}(n) \quad (14)$$

a) Power to operate the boilers' burners and the CHP engines: $\dot{W}_{Energy_unit_i_Operation}$

The three boilers were modulated individually at nine different positions, from their high fire to low fire: 776 m³/s and 105 m³/s of natural gas, respectively. Each of the 3 phase supplies was then monitored at each modulation position. Using the highest monitored current from the 3 phases and assuming a power factor of 0.8, the power for each modulation position was then calculated using Eq. (15).

$$\dot{W}_{Energy_unit_i_Operation}(n) = \sqrt{3} * V * I(n) * Cos(\varphi) \quad (15)$$

As the two CHP engines were set to operate at their respective maximum load, each engine's power consumption was calculated as for the boilers, but at their current single operating position.

b) Power to cool the boiler and the CHP engines: $\dot{W}_{Energy_unit_i_Cooling}$

The power consumption to operate the respective shunt pump to circulate the DH water through the boilers and through the flat plate heat exchanger connected to the CHP engine was monitored with an electromagnetic flow metering tool from ABB [20]. The power consumption to circulate the DH water through the boilers was monitored at three positions. For the CHP engines, as they operate only at maximum load, the power consumption to

circulate the DH water to their external flat plate heat exchanger was monitored at their single operating position.

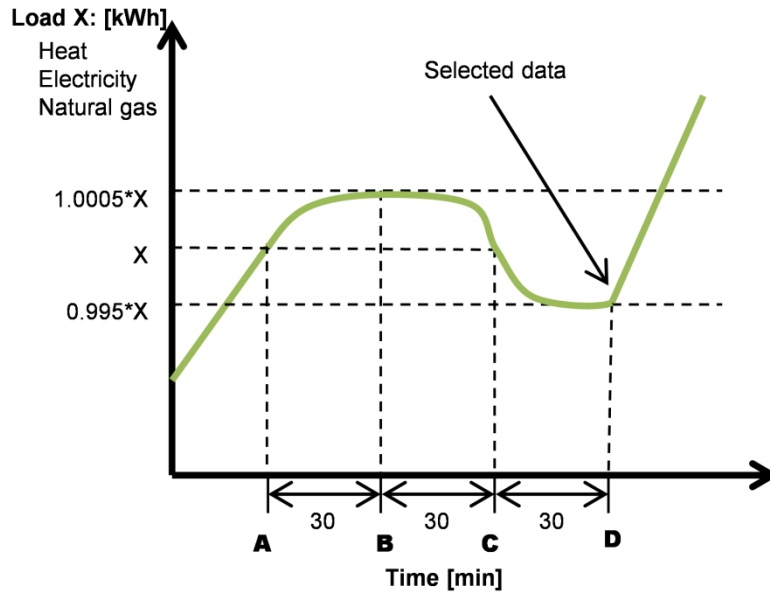

Figure 5 An illustration showing the requirements for data selection when steady-state operational conditions achieved

2.3 Alternative operation scenarios

The current operation of the plant was compared to 10 different alternative scenarios. The first series of scenarios analysed the performance of the plant while operating the current CHP engines at full load during the day tariff and by selecting the efficiency of the boilers by operating them at a known load for a minimum of four hours. This also minimises the number of start/stop operations. The second series of scenarios compared the operation of different CHP engines sizes operating them at full load during the day tariff .

The energy performance of the boilers and the CHP engines were assessed using the data collected from the Schneider database. Their respective energy efficiencies were then calculated using Eq. (16). The data was filtered according to Fig. 5, which selects data from the boilers or the CHP engines after having operated for at least 1 hour at constant load, hence in near steady-state condition.

$$\eta_{th}(n) = \frac{Q_{Generated_heat}(n)}{Q_{Natural_gas}(n)} \quad (16)$$

To complete the financial analysis of each scenario, the natural gas and the import and export electricity cost were selected after calculating the site's average natural gas cost and electricity export operating income in 2012. As the electricity consumption to operate the energy plant is less than 2% of its total energy consumption for every scenario, the export and import electricity cost were assumed to be similar and equal to the average obtained export electricity cost. Hence:

- Natural gas: 2.50 p/kWh
- Export electricity: 6.20 p/kWh

2.3.1 Baseline

The baseline assumed the buildings to be heated with individual natural gas boilers. The operation of the individual boilers also includes their supplementary power consumption. This power consumption was calculated with Eq. (17) that uses the benchmark obtained from Eq. (18). This benchmark was calculated using the PDHU energy centre as reference. It divides the annual power consumption to operate its boilers and CHP engines to the consumed natural gas.

$$W_{All_Energy_units} = \frac{Q_{Consumed}}{\eta_{Ind.Boiler}} * Benchmark_elec \quad (17)$$

$$Benchmark_elec = \frac{W_{All_Energy_units}}{Q_{Natural_gas}} \quad (18)$$

2.3.2 Scenario 2 - Operating the current CHP engines and the boilers at full load

As PDHU benefits from a 2,500 m³ accumulator, the heating cost can be reduced with a strategy that sets the boilers and the CHP engines to operate at full load and for longer hours. This increases the seasonal efficiency of the boilers, and increases the proportion of heat supplied from the CHP engines.

2.3.3 Scenario 3 - Selecting different sizes of CHP engines

The selection of CHP engines was assessed by assuming a 10 year repayment loan contract with an interest rate of 7% combined with a 10 year period maintenance agreement. The installation and maintenance costs were provided from an anonymous supplier and the calculation of repayment of the loan was carried out using the PMT function from Excel, see Eq. (19).

$$Annual_repayment = PMT(rate, nper, Pv) \quad (19)$$

Using energyPRO [21], a modelling software package for combined techno-economic design, the analysis and optimisation of cogeneration energy plant scenarios with different CHP engine sizes were simulated and compared. energyPRO simulates the dynamic operation of the energy plant and gives as a result the natural gas consumption and heat and electricity generation, it does not include the electricity consumed by the energy plant. The calculated electricity consumption from the site was included in the financial analysis. As the supplied heat is similar in every scenario, the calculated electricity consumption to pump the heat was also assumed to be similar. The electricity to operate the boilers and the CHP engines with their corresponding pumps was calculated using Eq. (17).

2.3.4 CO₂ emission analysis

PDHU through its lower carbon emission also plays a role in reducing the national carbon emission. The SAP CO₂ emissions factors of 0.198 kg CO₂/kWh and 0.517 kg CO₂/kWh for natural gas and for electricity respectively [22]. The CO₂ emissions from the plant was compared to an equivalent CO₂ emission corresponding to the CO₂ emissions that would have been emitted if the energy centre's generated heat and electricity had otherwise been provided from a traditional system of an individual boiler and grid electricity, see Fig. 6. The energy centre's CO₂ emissions were calculated using Eq. (20) and the equivalent CO₂ emission using Eq. (21):

$$CO_2 = Q_{Natural_gas} * 0.198 + W_{Energy.Centre} * 0.517 \quad (20)$$

$$CO_{2_equivalent} = \frac{Q_{Consumed}}{\eta_{Ind.Boiler}} * 0.198 + (W_{generated} + W_{Ind_boiler}) * 0.517 \quad (21)$$

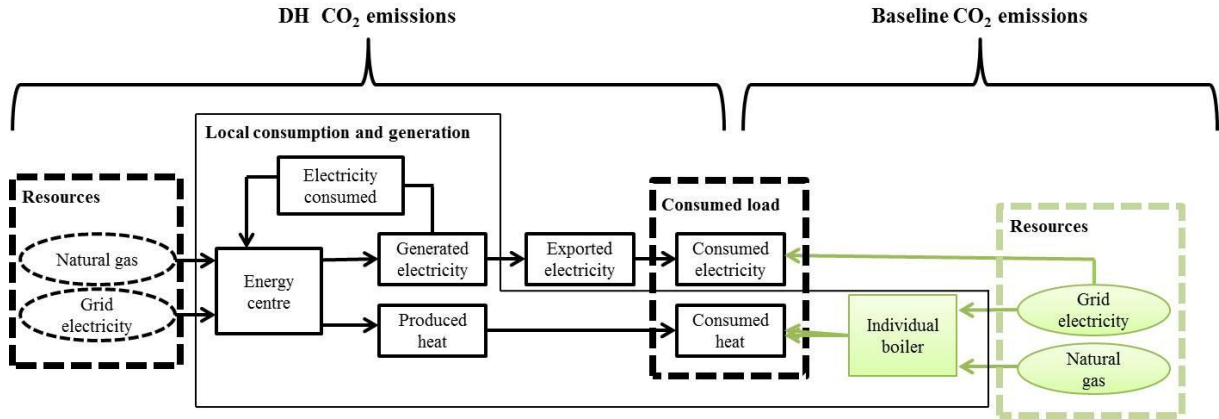

Figure 6 CO₂ emissions analysis

Although the energy centre also consumes some electricity generated, it was assumed that all the electricity generated from the site was exported to the grid and all the consumed electricity was provided from the grid. This increases the site's CO₂ emission of the same amount than the equivalent CO₂ emission. As the CO₂ reduction percentage is calculated from dividing the former value to the later value, the CO₂ reduction percentage reduces discreetly.

The financial analysis was not influenced by this because the electricity import and export cost were assumed to be similar.

3 Results and discussion

Throughout 2012, the energy centre consumed 74,440 MWh of natural gas and 827 MWh of electricity. This equates to 15,167 tonnes of CO₂ emissions, which is 8% lower than for the equivalent CO₂ emissions. PDHU operates its CHP engines in priority mode during the day. Although it benefits from a 2,500m³ accumulator, the CHP engines were at the beginning of the year not always set to operate at full load and were constantly shut down. Since the month of August, the two CHP engines have been operating more continuously and at full load during the day-tariff period from 06:00 to 23:00.

Fig. 7 shows that the day with the greatest heat demand was in February and was 280MWh. This daily heat demand reduces to approximately 50MWh in the summer.

The energy flow diagram, Fig. 8, gives the thermal and electricity flows from this DH scheme.

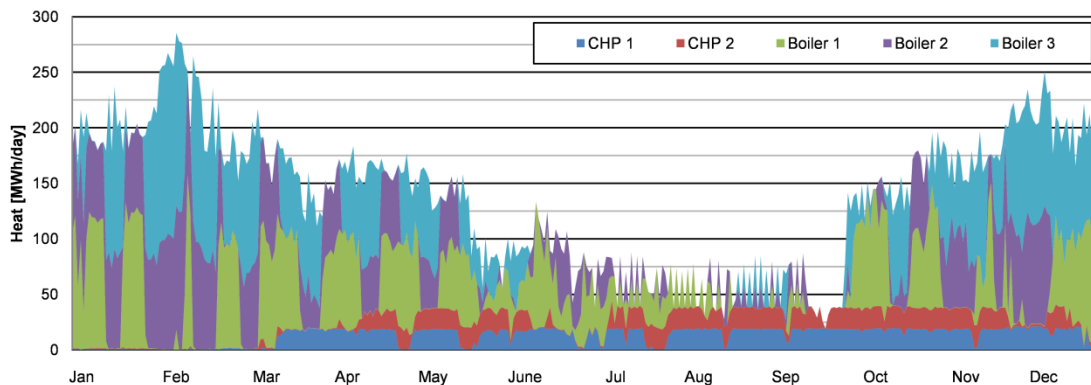

Figure 7 Annual daily heat demand at PDHU DH

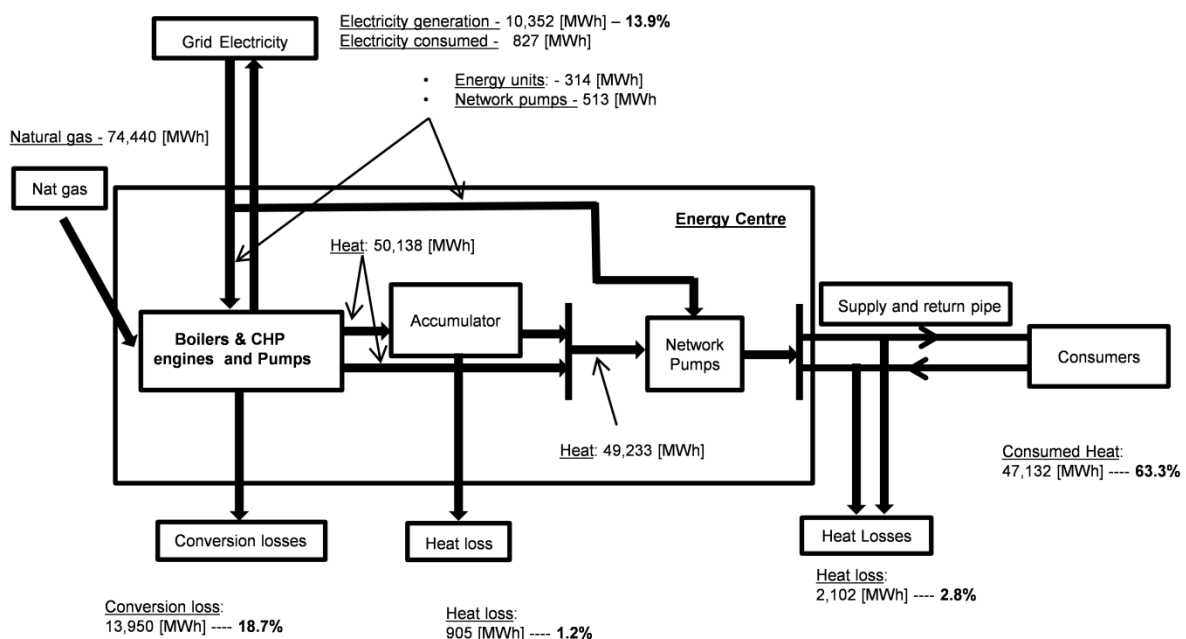

Figure 8 Natural gas conversion into heating and electricity in 2012

3.1 Energy Units Performances and Annual Energy Generation

3.1.1 Boilers' operation and performance

From the duration curve given in Fig. 11, it can be noted that boiler 1 and 3 were mostly set to operate at high loads whereas boiler 2 constantly operated at reduced loads. Fig. 9 gives the boilers' data filtered in accordance with Fig. 5. It can be seen that as the selected data from boiler 1 corresponded to when the boiler operated at high loads, a high efficiency of approximately 90% based on the high heating value was reported. The data selected for Boiler 2 are for part load operation; hence it shows a reduced operating efficiency of approximately 83%. Boilers filtered data shows an efficiency decreasing from approximately 90% to 83% with reducing load from boiler maximum load. This analysis is in line with the published literature on boilers' efficiencies and confirms that boilers should be set to only operate at full load [23]. Using the boilers' annual heat generation and annual natural gas consumption data, it was established that the three boilers operated with an average combined seasonal efficiency of 84.3%, which corresponds to approximately their minimum operating efficiency. This is because the boilers are allowed to start and stop frequently, hence operating on standby mode – off but hot, air circulates through them resulting in significant heat losses [14].

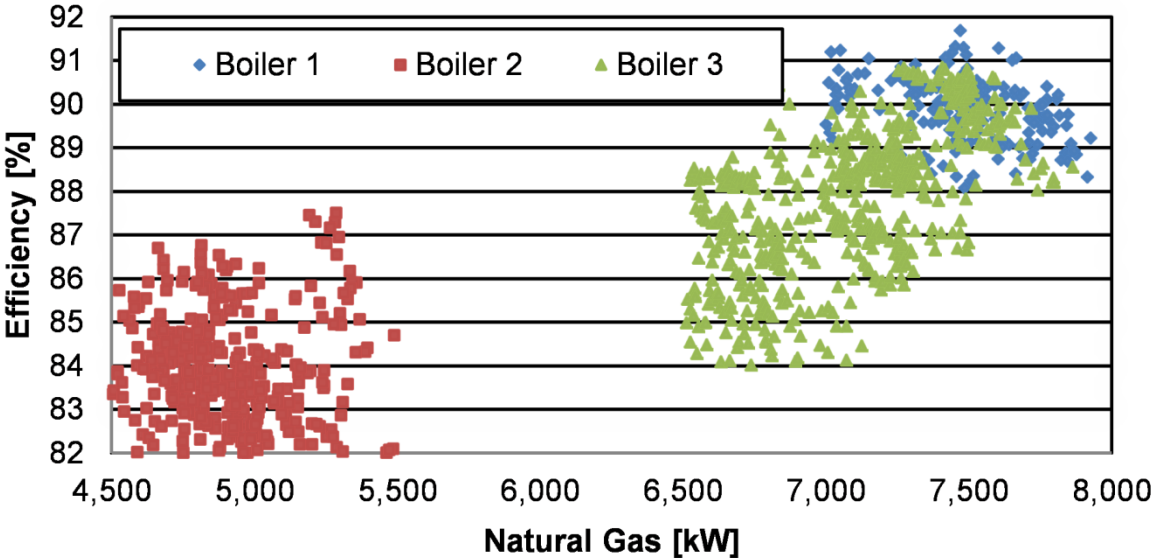

Figure 9 Boilers' modulation efficiencies – collected data

3.1.2 CHP engine performances

Due to electrical metering failure, less data for CHP engine 2 was collected and plotted in Fig. 10 than for CHP engine 1. However, the filtered data shows that both CHP engines modulate with similar efficiencies. Based on the HHV, Fig. 10 also showed that with increasing load, the electrical efficiency remains fairly constant at approximately 40% and that the thermal efficiency decreases from approximately 33% to 28%. It is more financially viable and reduces CO₂ emissions more when the engines are operated at full load.

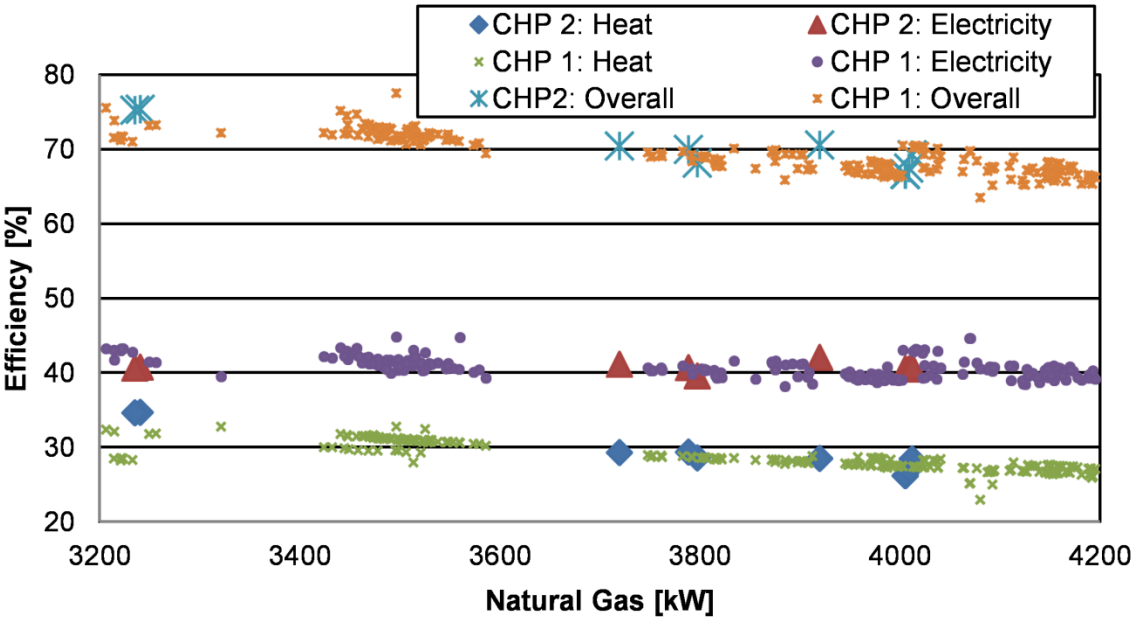

Figure 10 CHPs’ modulation efficiencies – collected data

3.1.3 Annual energy generation

Fig. 11 gives the boilers’ and CHP engines’ duration curve based on their natural gas consumption through the year. From this curve and from Fig.7, the annual heat generated and natural gas consumed from every energy unit is known. The total annual heat generated by these combined technologies equals 50,188MWh and the breakdown of this heat generated with the efficiency of its seasonal generation is given Table 1. From this, the natural gas consumption of this site can be calculated and is of 74,441 MWh (based on the HHV). The conversion loss is 13,951 MWh or 18.7%.

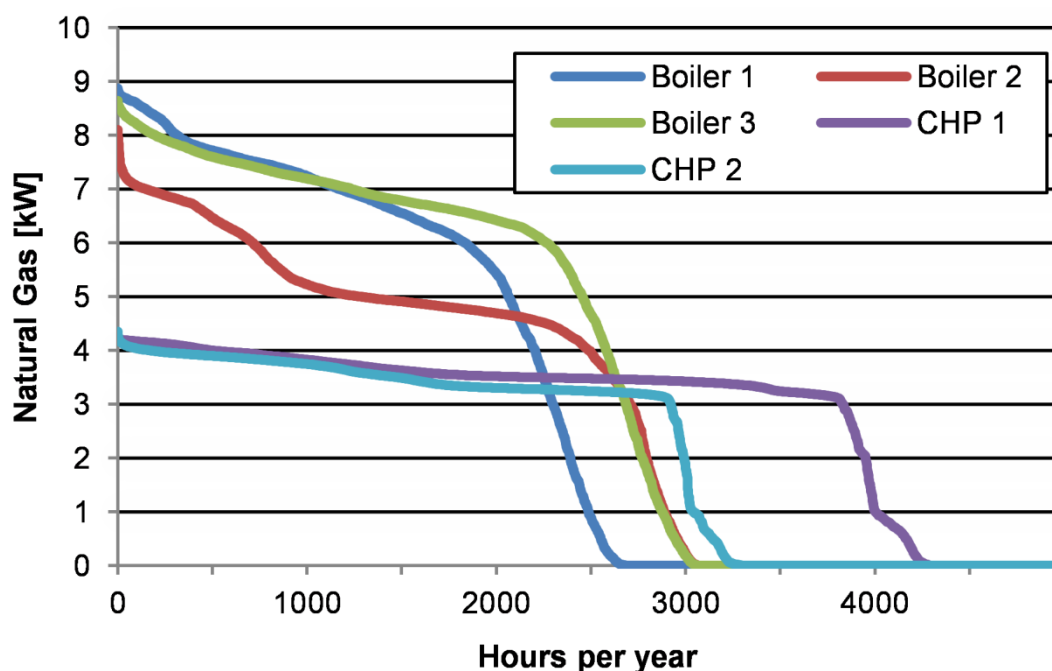

Figure 11 Duration curve based on natural gas consumption

Table 1: Annual Heat Generation

ANNUAL GENERATED HEAT AND ELECTRICITY				
	Natural gas MWh	Heat MWh	Electricity MWh	Overall efficiency MWh
Boiler 1	16,093	13,856	--	86
Boiler 2	14,676	12,125	--	82
Boiler 3	18,568	15,599	--	84
CHP 1	14,378	4,768	6,018	75
CHP 2	10,726	4,334	3,790	76

3.2 Heat Stored and Discharged from the Accumulator

Fig. 12 shows the dynamic level of the heat stored in the accumulator for a typical winter and summer week. The charged and discharged temperatures are 90°C and 60°C. The maximum storage capacity is calculated and is indicated by the horizontal line at 87 MWh in Fig. 12. Currently, the accumulator is set to discharge its heat when the heat level reaches the 2/3 of the accumulator's maximum capacity. Knowing the annual charging and discharging heat from the accumulator, 13,542 and 12,638 MWh respectively, the seasonal efficiency of the accumulator is calculated at 93.3%.

Fig. 12 also shows that in winter the accumulator charges and discharges twice a day, whereas in summer it charges every other day. Hence, the use and the operation of the accumulator could be improved by setting it to only charge once a day and letting the CHP engines operate in priority all through the day-tariff and letting the boilers operate at full load for a minimum of 4 hours. Hence, the current 2/3 maximum use of the accumulator could be exceeded when

required. Such operation of the accumulator would also minimise the number of start/stop cycles of the boilers.

Fig. 7 and Fig.12 also indicate that the site could benefit from the use of an additional CHP engine and increase their proportion of heat generation.

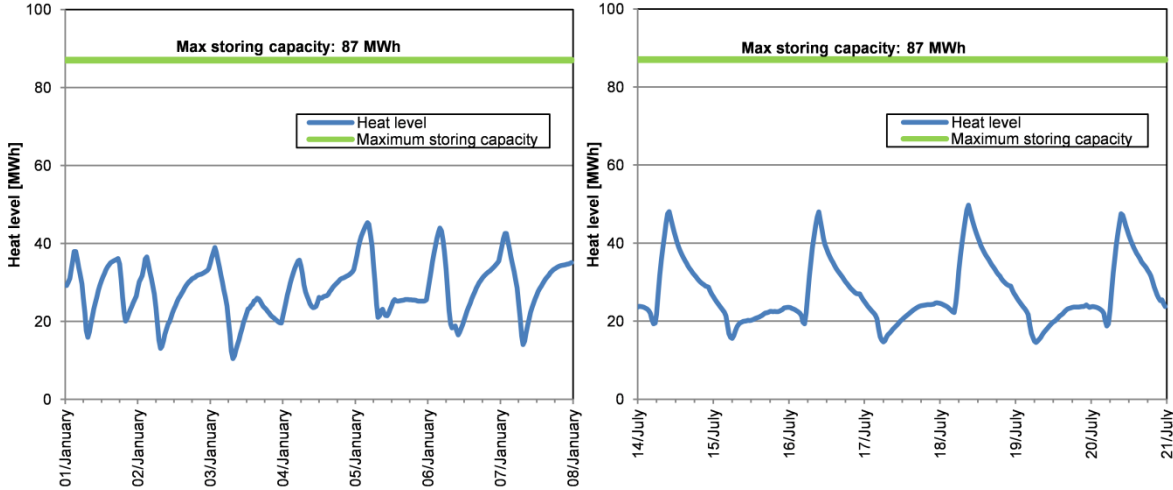

Figure 12 Accumulator dynamic heat level for a winter and summer week

3.3 Total Electricity Consumption from the Energy Centre

Fig. 14 gives the interpolation curves to calculate the power consumption to operate the boilers at any load and it also gives the power consumption to operate both CHP engines at their maximum load. With a reasonable correlation coefficient of 0.844, Fig. 15 gives the interpolation curve to calculate the power required to pump a known amount of heat to the network. The total electricity consumption for the energy plant can then be calculated through the year on a half-hourly interval basis. Every calculated power consumption value is plotted against its heat-power supplied to the DHN, see Fig. 13; the heat-power supplied negative values are for when more heat was charged to the accumulator than supplied to the DHN. Assuming that the calculated power consumption remains constant during the half-hourly intervals, the annual power consumption and CO₂ savings can be determined as follows:

- For the boilers and CHP engines: 314 [MWh/yr]
- For the network pumps: 513 [MWh/yr]
- Total: 827 [MWh/yr] or 428 Tonnes of CO₂ per year

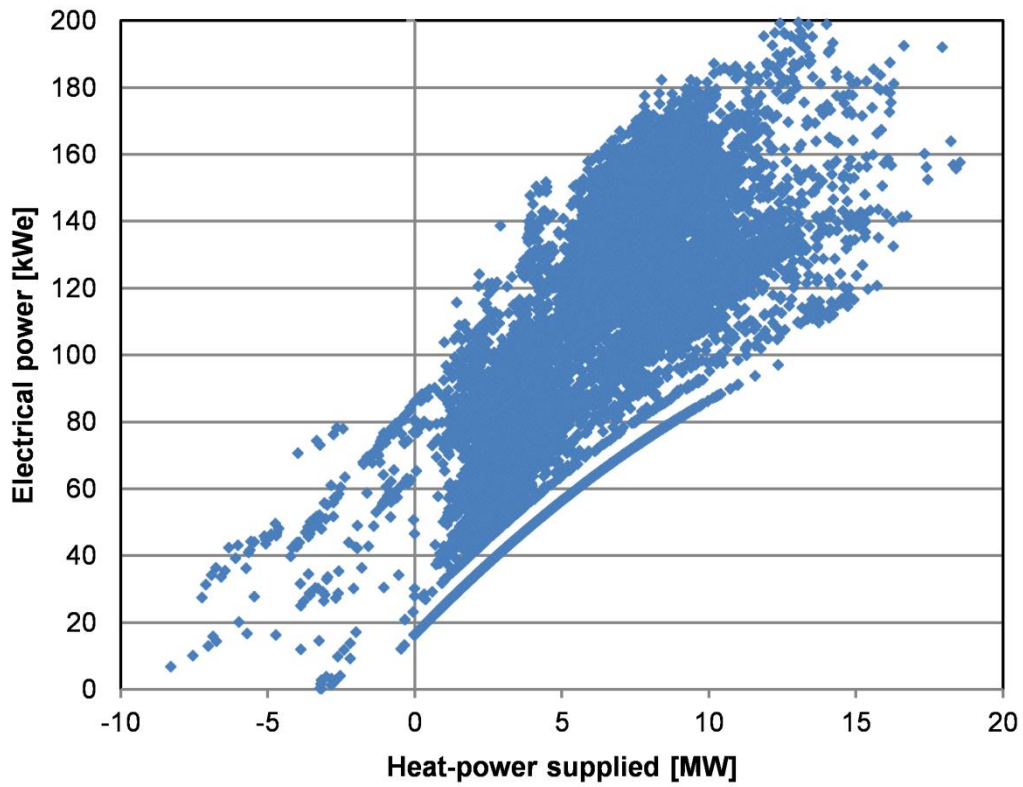

Figure 13 Total electricity consumption

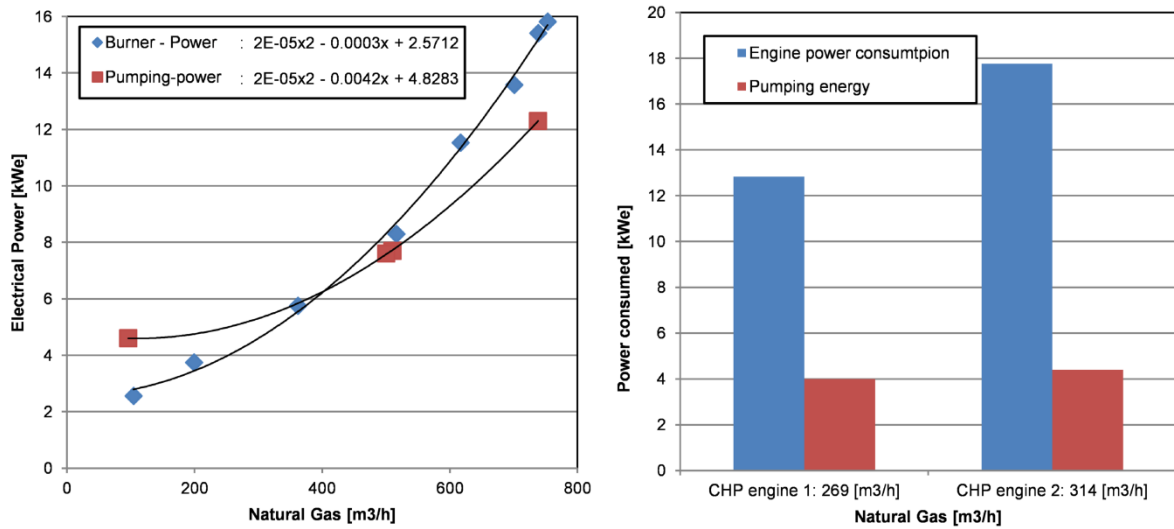

Figure 14 Energy units' electrical consumption

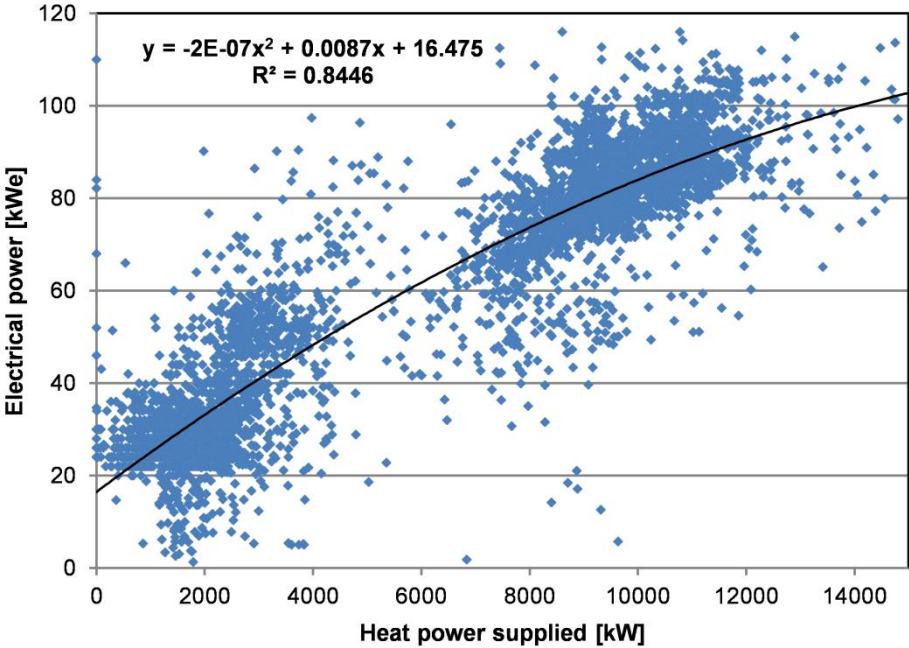

Figure 15 Electrical power to pump heat through the networks

3.4 Heat Losses to the Soil

A daily dynamic heat loss to the soil in Zone 1 was calculated using the data monitored on the 27th of November to calculate the heat supplied to the DHN as shown in Fig. 17. After calculating the simultaneous aggregated heat consumed from every consumer. The daily dynamic heat loss to the soil is the difference between the Power-Heat demand curve (Energy centre) and the Power-Heat consumed (Consumer) given in Fig. 16. Using the calculated daily heat supplied from the energy centre (26,935 kWh) and the daily heat consumed from the consumers (26,532 kWh), the daily heat loss to the soil is 403 kWh. The annual heat loss to the soil will be 147MWh or 2.5% of the total heat supplied.

With this annual heat loss and the length of this DHN (552 m), a heat loss per meter of pipe factor was calculated to be 266 kWh/(m·yr). This factor can be used in conjunction with the total length of the DHN (7,866 m) to calculate the total heat loss to the soil of PDHU DHN, this is 2,101 MWh/yr. Knowing the total heat supplied to the DHN (49,233 MWh/yr), the annual heat loss percentage to the soil from PDHU DHN is of 4.3%.

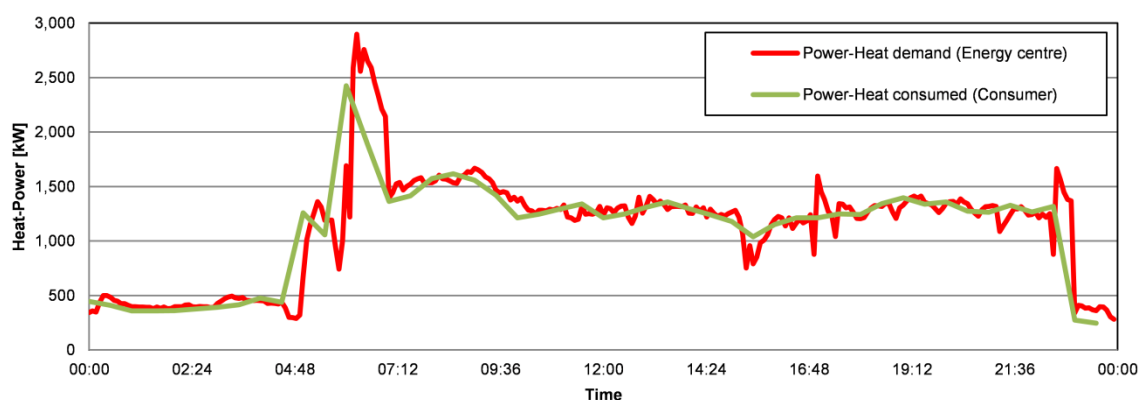

Figure 16 Dynamic heat loss to the soil; heat generated and heat consumed in Zone 1 on the 27th of November 2012.

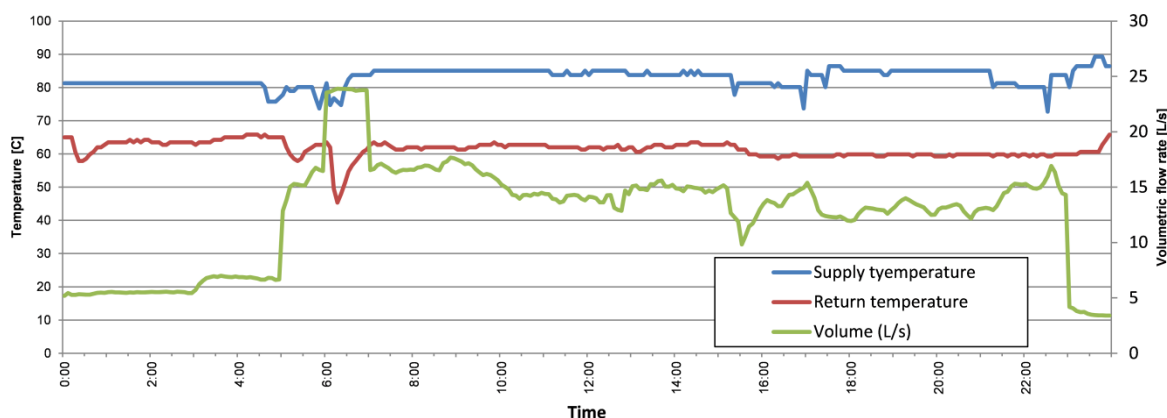

Figure 17 Zone 1 supply and return temperature and volumetric flow rate (29 November 2012)

3.4.1 Validation

Using monitored data, the calculated heat loss to the soil was 403 kWh. This heat loss calculation was compared to the theoretical loss using Fourier’s Law - Eq. (22) and was calculated to be 536 kWh [24]. This calculation used the parameters from Table 2 and the DH monitored average supply and return temperatures which were of 83°C and 61.5°C. It also assumed the insulation external surface in contact with the soil to be at London’s average soil temperature of 12°C [17].

Both values are very small compared to the total heat supplied and the theoretical calculation is only 33% higher. Hence, the heat loss theoretical calculation validates the heat loss calculation using monitored data.

None-the-less, this difference in value can be explained from the assumed external surface of the insulation required to solve Eq. (22); this temperature was assumed to be at the minimum possible temperature which is at the soil temperature of 12°C. This worst case scenario overestimates the theoretical heat losses to the soil.

Table 2 Heat loss to the soil calculation

USED PARAMETERS FOR HEAT LOSS TO THE SOIL CALCULATION													
Building connection		Pipe length m	Thermal conductivity W/(m ² *K)	Internal diameter mm	Thickness mm	Supply water °C	Return water °C	Soil °C	Supply pipe		Return pipe		
									Power kW	Daily kWh	Power kW	Daily kWh	
Pump House	Anson	127	0.023	165	42.5	83	61.5	12	3.1	75.3	2.2	52.5	
Anson	Ripley	60	0.023	165	42.5	83	61.5	12	1.5	35.6	1.0	24.8	
Ripley	Wilkins	75	0.023	165	42.5	83	61.5	12	1.9	44.4	1.3	31.0	
Wilkins	Sheraton	55	0.023	165	42.5	83	61.5	12	1.4	32.6	0.9	22.7	
Sheraton	Sullivan	65	0.023	165	42.5	83	61.5	12	1.6	38.5	1.1	26.9	
Sullivan	Gilbert	85	0.023	115	42.5	83	61.5	12	1.6	37.8	1.1	26.4	
Gilbert	Peabody	85	0.023	160	40.0	83	61.5	12	2.2	51.6	1.5	36.0	
TOTAL:		The daily heat loss to the soil = 316 + 220 = 536 kWh								315.8	220.2		

However, this difference may also be explained from the use of Class 2 heat meters at every consumer. Class 2 heat meters have a permissible error of 5% [25]. Taking this error in consideration, the heat consumption would become $26,343 \pm 490$ kWh and the heat loss to the soil would then become 403 ± 490 kWh. This would be neglecting the error from the supply heat, which is negligible because the heat supplied was calculated after monitoring with 5 minute interval the flow rate with a PT878 Panametrics Portable Ultrasonic Liquid Flow meter. This tool has a preciseness of 2% [26]; simultaneously the temperature of the steel supply pipe was monitored with a thermocouple which has an error of $\pm 0.4^\circ\text{C}$ [28].

$$q_r = \frac{2\pi Lk(T_{s,1} - T_{s,2})}{\ln(r_1/r_2)} \quad (22)$$

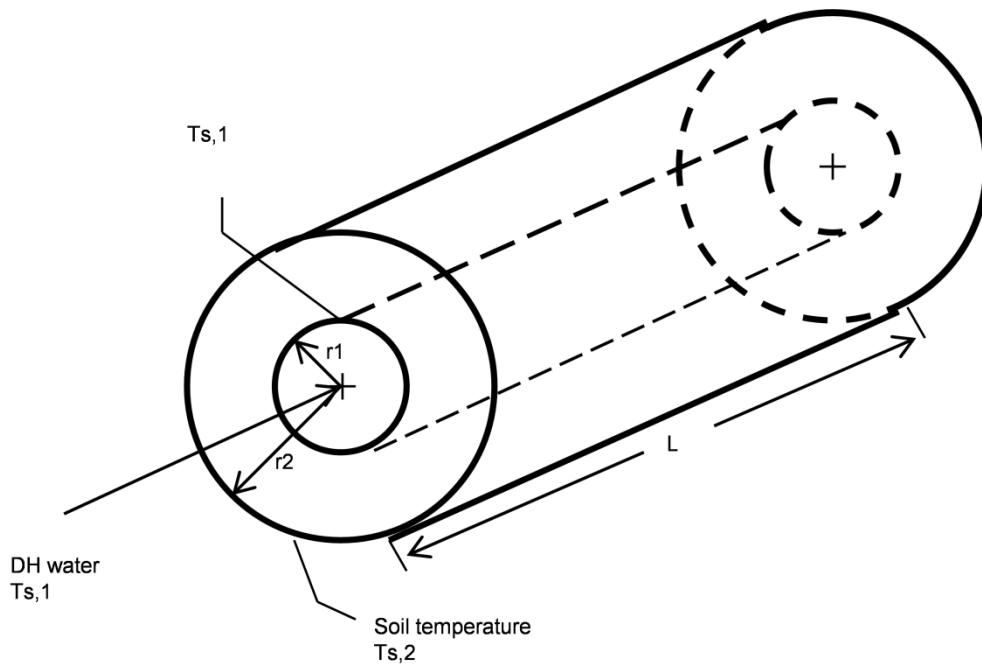

Figure 18 A schematic of an insulated pipe with surface boundary conditions

3.5 Modelling alternative operation

Two different series of scenarios have been modelled and compared with energyPRO. Table 3 gives a description of every simulated scenario and their respective main inputs and results are given in Table 4 and 5. Two bar charts showing the annual heating cost savings and the CO₂ emissions for each scenario are given in Fig. 19. These charts also compare the CO₂ emission and the heating cost savings if the boilers operate at their current seasonal efficiency of 84.3% and at their potential maximum operating efficiency of 91%.

Table 3 Analysed scenarios

Scenario	Description
<i>Scenario A</i>	Current operation of the plant
<i>Scenario B</i>	Baseline: Individual boilers operating at 85% efficiency installed in every block of building (no heat losses to the soil and from the accumulator).
<i>Scenario C</i>	The plant operates with no CHP engines and the boilers operate at the selected 91% efficiency.
<i>Scenario D</i>	The current CHP engine operate as in the current operation; the boilers operate at 85% efficiency.
<i>Scenario E</i>	The current CHP engines operate as in the current operation; the boilers operate at 91% efficiency.
<i>Scenario F</i>	The current installed plant is used with both current CHP engines at full load for as much as possible during the day tariff period. The boilers operate only at full load for a minimum of 4 hours with 91% efficiencies.
<i>Scenario G</i>	The plant is used with two new CHP engines of 2.7 MWe at full load for as much as possible during the day tariff period. The boilers operate only at full load for a minimum of 4 hours with 91% efficiencies.
<i>Scenario H</i>	The plant is used with two new CHP engines of 2.7 and 3.3 MWe at full load for as much as possible during the day tariff period. The boilers operate only at full load for a minimum of 4 hours with 91% efficiencies.
<i>Scenario I</i>	The plant is used with two new CHP engines of 3.3 MWe at full load for as much as possible during the day tariff period. The boilers operate only at full load for a minimum of 4 hours with 91% efficiencies.
<i>Scenario J*</i>	J1: The plant is used with two new CHP engines of 3.3 and 4.4 MWe at full load for as much as possible during the day tariff period. The boilers operate only at full load for a minimum of 4 hours with 91% efficiencies.
	J2: As above, but adjusted the given agreement maintenance cost by reducing it of 10%
<i>Scenario K*</i>	K1: The plant is used with two new CHP engines of 4.4 MWe at full load for as much as possible during the day tariff period. The boilers operate only at full load for a minimum of 4 hours with 91% efficiencies.
	K2: As above, but adjusted the given agreement maintenance cost by reducing it of 10%

3.5.1 Performance Comparison of Scenarios A to E

Table 4 compares the current operation of the plant, Scenario A, to Scenario B to E. In Table 4, the heating cost saving of the current operation of the plant is compared to Scenario B, while assuming the similar energy consumption cost. As Scenario C operates the plant with no CHP engines, the benefit from operating the CHP engines in Scenario A is assessed. Finally, it compares the savings from operating the boilers more efficiently: Scenario D and E operate similarly but the boilers are set to operate at 85% and 91% efficiency respectively.

Table 4 Current operation compared to (i) the Baseline, (ii) the plant operating with only boilers and (iii) the current plant operating the CHP engines similarly as in the current operation and the boilers operating with 85% and 91%

	Scenario A	Scenario B	Scenario C	Scenario D	Scenario E
Boilers' efficiency (%)	84.3	85.0	91.0	85.0	91.0
CHP 1 Size (kWe)	1,600	--	--	1,600	1,600
CHP 1 – Maintenance cost (£/hr)	14	--	--	14	14
CHP 2 – Size (KWe)	1,600	--	--	1,600	1,600
CHP 2 – Maintenance cost (£/hr)	14	--	--	14	14
CHP engines Installation cost (£)	--	--	--	--	--
Heat demand (MWh)	47,132	47,132	47,132	47,132	47,132
Heat produced (MWh)	50,138	47,132	50,138	50,138	50,138
Heat generated from CHP engine (MWh)	8,558	--	--	8,558	8,558
Natural gas consumed (MWh)	74,440	55,449	55,097	74,021	70,796
Electricity consumed (MWhe)	827	234	745	825	807
Electricity generation (MWhe)	10,352	--	--	10,352	10,352
CHP engine annual repayment (£)	--	--	--	--	--
Cost of source energy (£)	1,912,274	1,400,737	1,423,633	1,901,698	1,819,934
Heat cost savings	0	-39,712	-62,608	10,466	91,100
Source energy cost reduction (%)	0	--	-3	1	6
Site's CO ₂ emission (tonne CO ₂)	15,167	11,100	11,295	15,083	14,435
Equivalent CO ₂ emission (tonne CO ₂)	16,493	11,100	11,099	16,492	16,485
CO ₂ reduction (%)	8	0	-2	9	12

3.5.2 Performance Comparison of Scenarios F to K

Table 5 compares scenarios operating with different CHP engine sizes while operating the boilers at 91% efficiency. These scenarios each have two CHP engines and their total CHP capacity increases from 3.2 MWe to 8.8 MWe, with Scenario F being the lowest and Scenario K the highest. Scenario F operates the two current 1.6 MWe CHP engines. Hence, it also benefits from not having a repayment loan for purchasing new CHP engines in its financial analysis.

In all these scenarios, the boilers were set to operate at 91% efficiency and the CHP engines to operate at full load and when possible from 06:00 to 23:00, which corresponds to the electricity day-tariff. Every scenario included maintenance time for the good operation of the engines and requires the CHP engines to be turned off two days per month.

3.6 Results

Table 4 and 5 quantify the benefits from every scenario and Fig. 19 compares them graphically. From these tables and this figure, it can be appreciated that the current operation of the plant reduces the CO₂ emissions of 8% compared to its corresponding equivalent CO₂ emission. Fig. 20 and Table 4 show that Scenario C has a CO₂ emission 2% higher than the baseline. It emits a higher CO₂ emission because both scenarios generate heat with natural gas boilers, but the baseline does not have any heat losses to the soil nor from the accumulator and does not require any power to pump the water through the DHN.

Combining a good operation of the CHP engine, operating the boilers at the set efficiency of 91% and benefitting from not purchasing a new CHP engine, Scenario F becomes the option minimising the heating cost. However, as a little proportion of the heating load is generated by the CHP engines, the heating cost savings reduces significantly if the boilers efficiency reduces: If their seasonal efficiencies reduce by 1%, the heating cost savings for Scenario F reduces by £10,791 per year. This value can be compared to a reduction of £3,810 in scenario K, where a bigger proportion of heat is generated from the CHP engines. Furthermore, if the boilers' seasonal efficiencies reduce to 87%, scenario I gives the most heating cost savings and if the seasonal efficiency of the boilers reduces to 85%, Scenario K with the higher maintenance cost agreement contract also becomes a better scenario. Scenarios K and J include the new JMS 624 GS-N.L Jenbacher CHP engine, which includes a double turbocharger to improve its electrical efficiency. For this reason, the agreement maintenance cost for this CHP engine differs from Scenario J1 and K1 to Scenario J2 and K2. Scenario J1 and K1 used the given agreement maintenance cost which is currently higher by approximately 10% compared to typical values and Scenario J2 and K2 adjusted this cost to compare better the performance of both operating scenarios.

Table 5 The optimised operation of the current plant compared to scenarios operating with difference sizes of CHP engines

	Scenario F	Scenario G	Scenario H	Scenario I	Scenario J1	Scenario K1	Scenario J2	Scenario K2
Boilers' efficiency (%)	91.0	91.0	91.0	91.0	91.0	91.0	91.0	91.0
CHP 1 – Size (kWe)	1,600	2,679	3,349	3,349	4,397	4,397	4,397	4,397
CHP 1 – Maintenance cost (£/hr)	14	23	27	27	39	39	35	35
CHP 2 – Size (kWe)	1,600	2,679	2,679	3,349	3,349	4,397	3,349	4,397
CHP 2 – Maintenance cost (£/hr)	14	23	23	27	27	39	35	35
CHP engines Installation cost (£)	--	2,484,055	2,715,128	2,946,191	3,307,600	3,669,039	3,307,600	3,669,039
Heat demand (MWh)	47,132	47,132	47,132	47,132	47,132	47,132	47,132	47,132
Heat produced (MWh)	50,138	50,138	50,138	50,138	50,138	50,138	0	50,138
Heat generated from CHP engine (MWh)	14,784	27,256	29,736	31,976	34,781	37,655	34,781	37,655
Natural gas consume (MWh)	84,507	99,123	103,100	106,760	112,511	117,870	112,511	117,870
Electricity consumed (MWhe)	877	931	948	963	988	1,010	988	1,010
Electricity generation (MWhe)	18,262	28,668	31,454	33,942	38,070	41,917	38,070	41,917
CHP engine annual repayment (£)	--	-353,674	-386,573	-419,471	-470,928	-522,389	-470,928	-522,389
Cost of source energy (£)	2,167,060	2,535,816	2,636,264	2,728,736	2,874,006	3,009,392	2,874,006	3,009,392
Heat cost savings (£)	166,437	49,960	77,757	88,352	84,591	82,777	106,624	120,070
Source energy cost reduction (%)	9	3	4	5	4	4	6	6
Site's CO ₂ emission (tonne CO ₂)	17,186	20,108	20,904	21,637	22,788	23,861	22,788	23,861
Equivalent CO ₂ emission (tonne CO ₂)	20,609	26,013	27,462	28,756	30,903	32,905	30,903	32,905
CO ₂ reduction (%)	17	23	24	25	26	28	26	28

3.6.1 Sensitivity analysis

Fig. 20 shows the results from a sensitivity analysis. The chart on the left compares the scenarios after reducing the original interest rate on the loan from 7% to 4% for purchasing new CHP engines. The chart on the right compares the effect of increasing the original electricity import and export cost from 0.062 £/kWh to 0.07 £/kWh. In both sensitivity analyses, it is found that reducing the interest rate and increasing the electricity cost have a beneficial impact on larger CHP engines investment and favours Scenario K operating with two CHP engines of 4.4 MWe.

In both sensitivity analyses, it is found that reducing the interest rate and increasing the electricity cost have a beneficial impact on larger CHP engines investment and favours Scenario K operating with two CHP engines of 4.4 MWe.

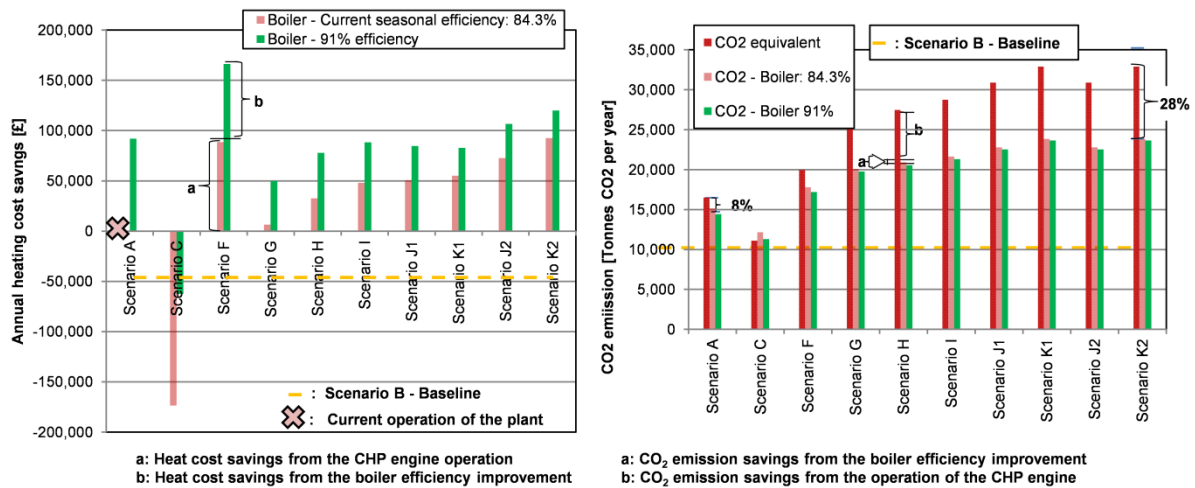

Figure 19 Scenario comparisons: Heat cost and CO₂ emissions savings. These scenarios are all compared to the baseline given with the dashed line in both charts

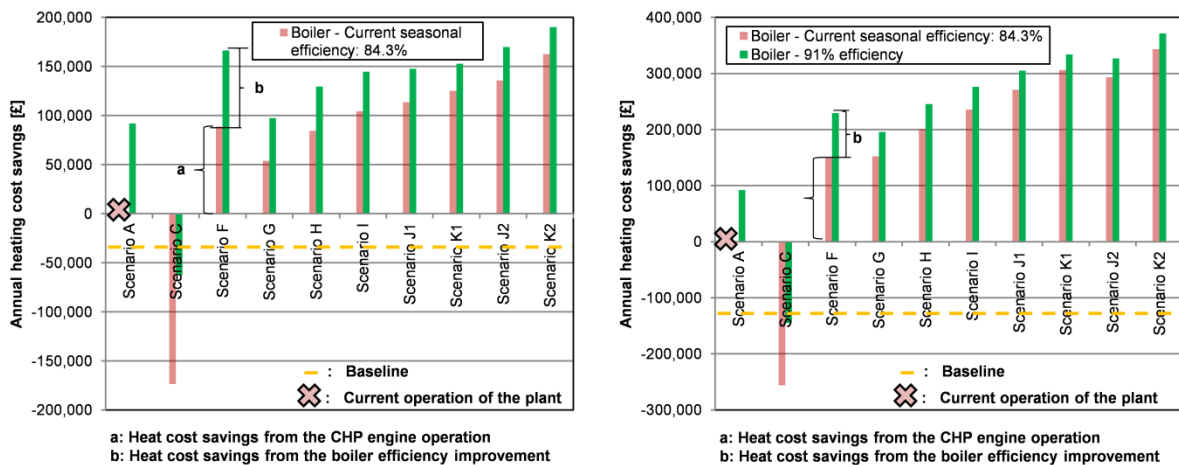

Figure 20 Sensitivity analysis: Interest rate is reduced from 7% to 4% (left), and export and import electricity costs are increased from 0.062 to 0.07 £/kWh (right)

With an interest rate set at 7% and with the current electricity cost, Scenario F was the scenario maximising the heating cost savings. However, scenario J2 and K2 provide more heating cost savings when reducing the CHP engine’s loan interest rate from 7% to 4%; and Scenario H through to Scenario K become better scenarios than scenario F if the electricity cost increases from 0.062 £/kWh to 0.07 £/kWh.

4 Conclusion

PDHU was analysed and compared to different scenarios. Its accumulator is currently under used and this will not change unless more consumers connect to its DHN or by changing operating strategies and/or technologies to generate the heat, such as letting the CHP engines operate at night. The selection of a new CHP engine to minimise the heating cost is greatly influenced by (i) its maintenance agreement cost, (ii) the interest rate for purchasing it and (iii) the export electricity cost. Therefore, the scenario reducing the heating cost most was Scenario F, which optimises the operation of the current plant and benefits from not purchasing any new equipment. However, from the sensitivity analysis, it was noticed that if the interest rate from the loan for purchasing new CHP engines is reduced and if the export electricity cost is increased, scenario K including two 4.4 MWe CHP engines becomes the scenario minimising the heating cost and the CO₂ emissions. Hence, operating the boilers full load and purchasing additional CHP engine capacity reduces the heating cost. However, additional CHP engine capacity is deemed to be a better way to also minimise the CO₂ emissions. Finally, in practice and if enough space, operators would rather add an additional CHP engine capacity rather than replacing the current CHP engines; a further analysis should be investigated to finding the optimum size for adding more CHP capacity to the plant.

References

- [1] Hawkey, D., 2009. *Will "District Heating Come to Town"? Analysis of Current Opportunities and Challenges in the UK*, University of Edinburgh.
- [2] International Energy Agency, 2011. *District Heating for Energy Efficient Building Areas*. Paris: IEA.
- [3] Reidhav, C. and Werner, S., 2008. Profitability of sparse district heating. *Applied Energy*, vol. 85, no. 9, pp. 867-877.
- [4] Davies, G. and Woods, P., 2009. *The Potential and Costs of District Heating Networks*. 204. Oxford: Pöyry Energy.
- [5] Bøhm, B. and Larsen, H., 2004. *Simple models of district heating systems for load and demand side management and operational optimisation*. Technical University of Denmark: Risø National Laboratory.
- [6] Wigbels, M. and Bøhm, B. and Sipilae, K., 2005. *Dynamic Heat Storage Optimisation and Demand Side Management*. Paris: IEA.
- [7] International Energy Agency, 2008. *District Heating Distribution in Areas with Low Heat Demand Density*, Paris: IEA.
- [8] Gabrielaitiene, I., Bøhm, B. and Sunden, B., 2007. Modelling temperature dynamics of a district heating system in Naestved, Denmark – A case study. *Applied Energy*, vol. 48, no. 1, pp. 78-86.
- [9] Benonysson, A., Bøhm, B. and Ravn, H., 1995. Operational optimization in a district heating system. *Energy Conversion and Management*, **36**(5), pp. 295-314.

- [10] DECC, 2009. *Climate Change Act 2008 Impact Assessment*. Final. London: DEFRA.
- [11] Greater London Authority, 2010. *Delivering London's Energy Future*, London: GLA.
- [12] department of Energy & Climate Change, 2003. *The Future of Heating: Meeting the challenge*.
- [13] Koronakis, J. Air conditioning – Energy consumption and environmental quality. *Encyclopedia of life support systems*. Eolss.
- [14] Jones, P., 2004. Energy-efficient boilers & burners. *Fundamental Series*, July/August, series 2, Module 04.
- [15] Woods, P.S., 2011. CHP and district heating – how efficient are these technologies? CIBSE Technical Symposium, DeMontfort University, Leicester UK – 6th and 7th September 2011.
- [16] Cogen Europe, 07/02/2009, 2009-last update, What is Cogeneration? [Homepage of COGEN europe], [Online]. Available: http://www.cogeneurope.eu/what-is-cogeneration_19.html [10/01, 2011].
- [17] Metoffice, Retrieved May 25, 2013, from <http://www.metoffice.gov.uk/climate/uk/so/print.html>
- [18] GE Sensing: www.gesensing.com, TransPort PT878 Panametrics Portable Ultrasonic Liquid Flowmeter, 2005.
- [19] MicroDAQ, Retrieved May 30, 2013, from <http://www.microdaq.com/occ/accessories/extsensors.php>
- [20] Aquamaster 3 Electronic Water Meter, ABB, specifications [online], Available from <http://www.abb.com/cawp/seitp202/78ba3942bb164cedc125789a0033247f.aspx> [Accessed 5 September 2013].
- [21] Download energyPRO 4. EMD International A/S, 2012.
- [22] DECC, 2009. *The Government's standard Assessment Procedure for Energy Rating of Dwellings*. 9.90. Garston, Watford WD25 9XX: BRE.
- [23] Palsson, O.P., Ravn, H.F., 1994. Stochastic heat storage problem—solved by the progressive hedging algorithm. *Energy Conversion and Management*, **35**(12), pp. 1157-1171.
- [24] Incropera, F.D.,David, ed, 1996. *Fundamentals of Heat and Mass Transfer*. Fourth edition edn. USA: John Wiley & Sons.
- [25] GasTec at CRE, Heat metering for the RHI, DECC, September 2010
- [26] GE Sensing: www.gesensing.com, TransPort PT878 Panametrics Portable Ultrasonic Liquid Flowmeter, 2005.

[27] schneider electric UK, www.schneider-electric.co.uk.

[28] MicroDAQ, Retrieved May 30, 2013, from
<http://www.microdaq.com/occ/accessories/extsensors.php>

APPENDIX D COMPARISON AND EXERGY ANALYSIS OF HEAT SUPPLY SCENARIO FOR A 50,000 MWH DISTRICT HEATING SYSTEM (PAPER 4)

Full Reference

Martin-Du Pan, O., Eames, P., Rowley, P., Bouchlaghem, D., Susman, G., 2014. Comparison and exergy analysis of heat supply scenarios for a 50,000 MWh district heating system. *Eurosolar, the 8th international renewable energy storage conference*. 7-8 November, Berlin.

Abstract

The Mayor of London plans to deliver 25% of London's energy needs through decentralised energy systems by 2025. District heating can play a major part in achieving these aims. This paper investigates operational strategies for lower running costs and CO₂ emissions in a 50,000 MWh district heating scheme that supplies 3,256 residential and 55 commercial units. Current operation is compared to three alternative scenarios. The first scenario operates the plant with larger and financially optimised new CHP engines. The second scenario operates with a single open-loop heat pump. Finally, the third scenario combines both technologies: The two current CHP engines and the open-loop heat pump. The overall conclusion is that in the UK if located in an appropriate environment, operating a heat pump in conjunction to a CHP engine is an effective strategy for future district heating scheme design.

1 Introduction

District heating (DH) is defined as the local supply of heat from an energy plant to end users. In order to meet the current energy demands of London's homes, business and infrastructure through the provision of low and zero carbon energy, the Mayor plans to deliver 25% of London's energy needs through decentralised systems by 2025 [1]. However, this needs to be achieved while guaranteeing affordability and energy security. By 2050, the UK aims to reduce its CO₂ emission by 80%; to achieve this, heating will have to become almost zero carbon.

Encouraged by this policy, this paper compares different operational scenarios for an existing 50,000 MWh DH system located in Pimlico, central London. Pimlico DH includes two 1.6 MWe CHP engines operating as the lead heat source during the day tariff, three 8 MWth boilers and a 2,500 m³ accumulator. At present, the accumulator is used to balance the heating load and operate the CHP engines at full load. A network of insulated pipes transports the heat from the energy plant to 3,256 consumers and 55 commercial units. This paper compares the energy consumption and generation, the financial analysis, the CO₂ emissions and the overall exergy efficiency of the plant while operating under different scenarios. The first scenario selected new larger combined heat and power (CHP)

engines to increase the proportion of heat supplied by them while operating in conjunction with the 2,500 m³ thermal accumulator. The accumulator allows operating the CHP engines all through the electricity day-tariff and the boilers for a minimum of 4 hours; this reduces consumers' heating costs and system CO₂ emissions. The second scenario selected a ~12 MW open-loop heat pump connected to the river Thames to firstly store at night hot water in the accumulator at 75°C, while benefitting from a lower electricity tariff and carbon factor; this water can then be supplied to the network directly or after being upgraded in temperature with the heat pump. The third scenario operates the heat pump in priority at night, but during the day, the current two 1.6MWe CHP engines operate in priority to the heat pump.

2 Method

2.1 Description of the system

Pimlico district heating (DH) generates heat and power with two 1.6 MWe CHP engines and three 8 MWth boilers. The Energy Centre (EC) also benefits from a 2,500 m³ accumulator that helps to balance the heat generated and heat loads on the system, see Figure 1.



Figure 1: Element of the district heating scheme. Tower block with residences served by the visible accumulator (1), header with flow to the 5 zones in Churchill Gardens (2), a calorifier with “U” bend tubular heat exchangers (3) and a 1.6 MWe CHP engine (4)

2.2 Alternative operation scenarios

Pimlico DH operates its CHP engines full load during the day to benefit from the day tariff period from 06:00 to 23:00. It then pumps the heat to the consumers through its district heating network (DHN). The supply temperature varies depending on the outside temperature and on the heating load and ranges between 80°C and 90°C. The average return temperature was measured to be of 61.5°C. For the three analysed scenarios, the return DH water temperature was assumed to be continuously equal to 60°C and the accumulator to be used at 90% of its full capacity.

Scenario 1

From a detailed analysis of monitoring data, two 4.4 MWe CHP engines were selected to minimise the heating cost at the consumers while assuming similar operation of the DHN (similar supply temperatures and flow rates). The CHP engines operate in priority to the boilers and dynamic full load during the day tariff from 06:00 to 23:00.

Scenario 2

The plant operates with a single open-loop heat pump: UNITOP 50FY-91810U. Its heating load capacity ranges from 11.15 MW to 15.8 MW depending on its operating mode and on the river Thames temperature. The heat pump operates at the following three different modes:

- Mode 1: It upgrades the return DH water from 60°C to 75°C
- Mode 2: It upgrades the stored heat from the accumulator from 75°C to 90°C
- Mode 3: It upgrades the return DH water from 60°C up to 90°C

The heat is then pumped from the EC with a flow rate of 100 kg/s and a temperature ranging from 60°C to 90°C; when the supply temperature reaches 90°C, the flow rate increases to meet the heating demand.

At night, Mode 1 is used to charge the accumulator with hot water at 75°C and to meet the heating demand, while benefitting from the electricity night-tariff. As the heating load is reduced at night, the supply temperature is always lower than 75°C and is obtained after mixing the stored water with some return DH water with the use of a bypass. At the start of the day, the accumulator is fully charged and Mode 2 operates to meet with the accumulator the DHN heat demand. If the supply temperature is lower than 75°C, the accumulator supplies on its own the heat to the DHN. If the supply temperature is greater, the temperature is obtained after mixing up the generated heat from Mode 2 with additional heat from the accumulator. Mode 2 gives the benefit to the EC to comply with the morning heat peak demand. When the accumulator is discharged, Mode 3 starts-up and supplies the total heating demand that then never exceeds the capacity of the heat pump. When the supply temperature is lower than 90°C, the generated heat mixes up with a bypass some return DH water to obtain the right supply temperature.

Scenario 3

The plant operates with a similar heat pump to that in Scenario 2 and also pumps the heat at the set flow rate of 100 kg/s with a temperature ranging from 60°C to 90°C. When the supply temperature reaches 90°C, the set flow rate increases to meet the heating demand. At night, the plant operates similarly to than in Scenario 2. During the day and if the

accumulator is still charged with heat at 75°C, the accumulator operates on its own if the supply temperature is lower than its temperature. When the supply temperature is greater than 75°C, both current 1.6 MWe CHP engines operate in priority to the heat pump to generate and supply with the accumulator the heat to the DHN. The CHP engines heat up the return DH water from 60°C to 90°C and the heat pump operates at Mode 3. If the accumulator is discharged, the heating load is then met by the CHP engines that operate as in Scenario 2. In this paper, the heat pump operating at Mode 3 was assumed to be large enough to generate the remaining heat load.

2.3 Comparison assessment

As scenarios may be more attractive on some aspects, the current operation of the plant was assessed and compared to the three analysed scenarios following different approaches: An energy analysis, a financial analysis, a CO₂ emission analysis and an exergy efficiency indicator.

2.3.1 Energy analysis

The energy analysis was assessed after monitoring and calculating the energy consumption and generation of the current operation of the plant. The energy consumption and generation of the plant were reported on a 30 minute interval period for the complete year 2012. This analysis was necessary to assess the consumption and generation of the other scenarios and to carry out the comparison analysis.

2.3.2 Financial analysis

The financial analysis was assessed by comparing the heating cost in every scenario. The heating cost was obtained after calculating the energy consumption, the repayment loan and the maintenance agreement. The repayment loan for the purchase of a heat pump or a CHP engine assumed a 10 year repayment contract with a 7% interest rate and was calculated using Excel function to calculate the annual payment for a loan. The cost, including VAT, for purchasing either two 4.4 MWe CHP engines or the selected heat pump is:

- Two 4.4 MWe CHP engines installation cost: £3,669,039
- Heat pump unit and delivery cost: £ 5,173,770; for this paper, the installation cost was assumed to be the heat pump delivery cost and the euro to pound currency exchange rate was assumed to be 1.22.

The natural gas and export electricity cost were estimated by calculating the site's average natural gas and export electricity operating cost in 2012, which were:

- Natural gas: 0.025 £/kWh
- Export and import electricity – day tariff: 0.062 £/kWh
- Electricity night tariff: 0.03 £/kWh

Knowing the annual heating load demand on a 30 minute period basis, every scenario was simulated accordingly to obtain their energy consumed and generated. The financial analysis was then completed by converting these energies into cost and adding to it the energy unit repayment loan and the maintenance agreement contract cost.

2.3.3 CO₂ emission analysis

Using SAP carbon factors for the natural gas and the electricity (0.198 and 0.517 kg CO₂/kWh respectively) [4], an equivalent CO₂ emission for each scenario was then compared to the Baseline as shown in Figure 2. The Baseline assumes the use of the UK traditional system in which individual natural gas boilers operating with an average 85% seasonal efficiency based on the high heating value and the generated electricity load to be provided from the national grid as shown in Figure 2.

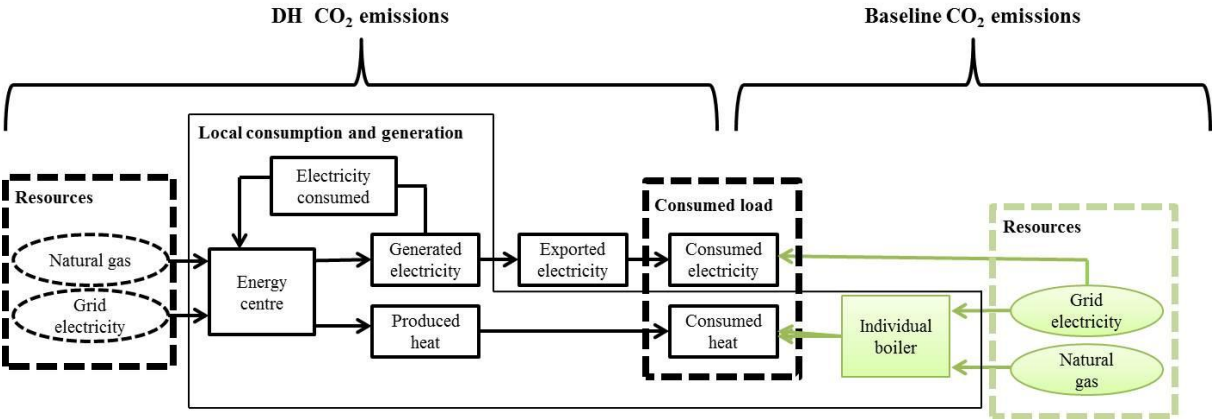

Figure 2: CO₂ emissions analysis

2.3.4 Exergy efficiency analysis

Exergy is defined as the potential of maximum work which can ideally be obtained from each energy unit and system [2]. According to Favrat et al. [3] the exergy approach allows to quantify in a coherent way, both the quantity and the quality of the different forms of energy considered. Compared to other efficiency definitions, the exergetic efficiencies are never bigger than 100% and are compatible with all cases of energy conversions and for all energy services. It indicates the relative quality of the conversion and therefore the different technologies can be put into competition. However, exergy does not appreciate the benefit from the use of a renewable fuel compared to fossil fuel or nuclear and does not

consider energy policy incentives. For those reasons, the exergy analysis cannot be undertaken on its own, but also requires a financial and a CO₂ emission analysis of the site.

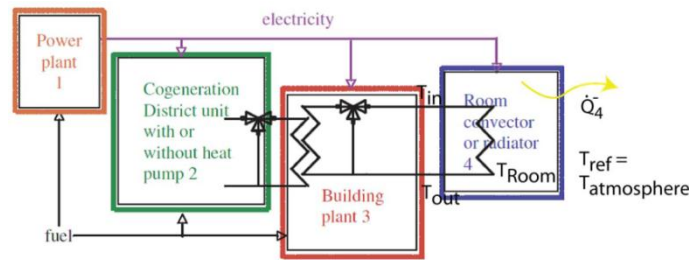

Figure 3: Example system definition illustrating the system boundaries, Favrat et al. [3]

Assuming a constant atmospheric temperature of 5°C, the overall system exergy efficiency of the defined systems can be calculated using the definition Equation (1), where η is the exergy efficiency, \dot{E} is the mechanical and electrical work, \dot{E}_q is the heat exergy and \dot{E}_y is the transformation exergy.

$$\eta = \frac{\sum \dot{E}^- + \sum \dot{E}_q^- + \sum \dot{E}_y^-}{\sum \dot{E}^+ + \sum \dot{E}_q^+ + \sum \dot{E}_y^+} \quad (1)$$

In this equation, all terms are positive, differencing between the terms entering the system with “+” sign and the positive terms (services) delivered by the system with a “-“ sign.

3 Results and discussion

Figure 4 gives the 2012 thermal and electricity flows from the DH system. These values are compared and used in every analysis for each scenario.

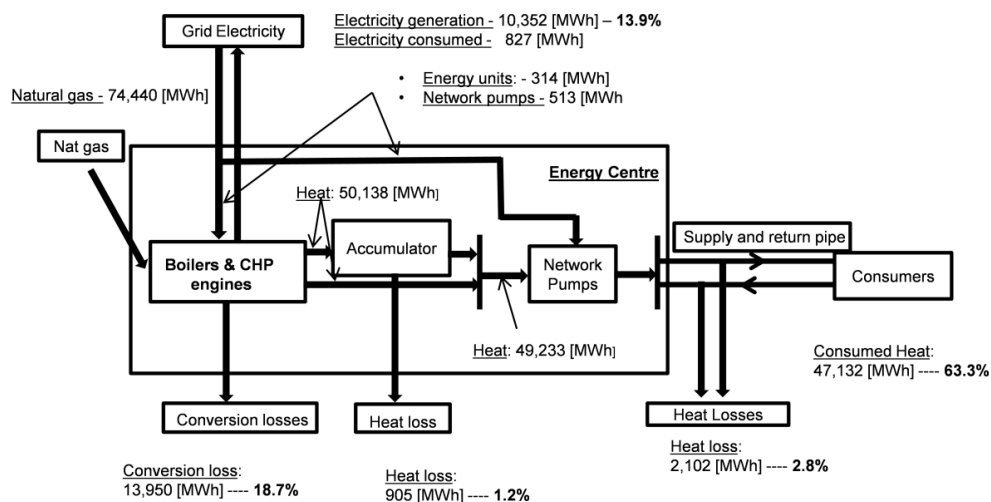

Figure 4 Natural gas conversion into heating and electricity in 2012

Figure 5 shows the annual heat load of the current operation of the DH system. This heat load reports the daily heat generated from each CHP engine and boiler. It indicates the day with the highest heat load and also compares the daily winter heating load to the reduced daily summer heating load.

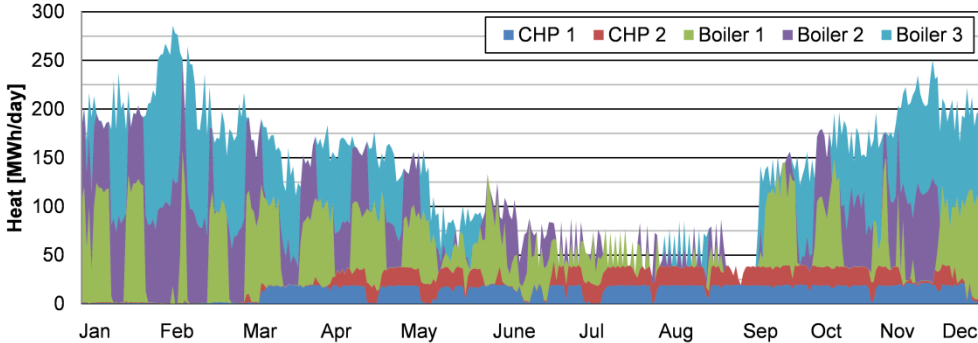

Figure 5 Annual daily heat generation at Pimlico district heating

3.1 Energy analysis

Table 1: Energy consumed to operate each scenario

	Electricity consumption				Natural gas consumption
	Heat pump	DHN	River pumping	Boilers and/or CHP engine	Boilers and/or CHP engine
	MWhe	MWhe	MWhe	MWhe	MWhe
Current operation	--	513	--	314	74,440
Scenario 1	--	513	--	497	117,870
Scenario 2	17,163	701	793	--	--
Scenario 3	13,881	701	614	135	32,082

Table 8 compares the energy consumption of every scenario. Figure 6 shows the annual daily heating load generation and its distribution among the used technologies and operating mode of the heat pump. It can be appreciated on the left chart in Figure 7 that although Mode 2 does not generate a large proportion of the heat generated when operating in Scenario 2, it does reduce the morning peak heating load generation from ~18 MW to less than 8 MW. This happens because Mode 2 upgrades in temperature the accumulator water from 75°C to 90°C. For this reason, the selected heat pump can operate on its own and does not require an additional energy unit to generate additional heat to meet the morning heat peak load demand.

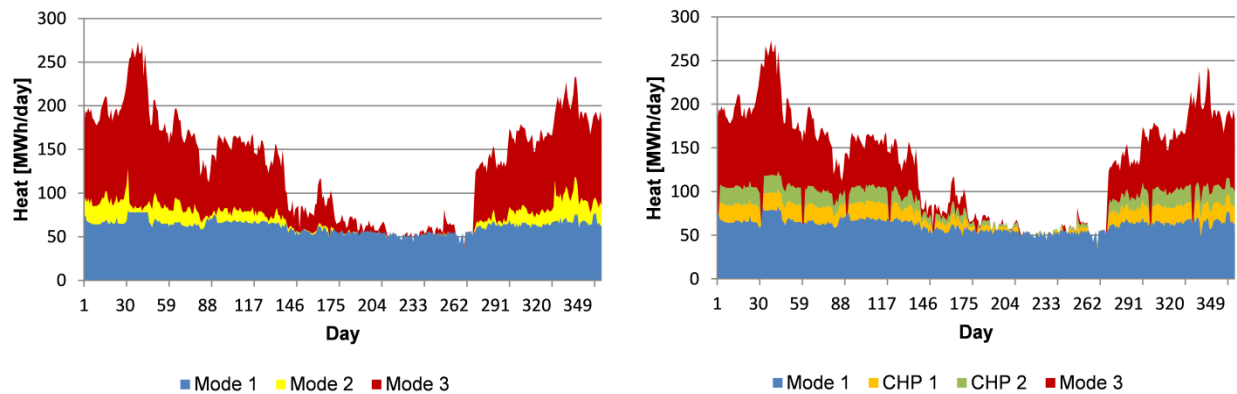

Figure 6 Annual daily heat generation for Scenario 2 and 3 respectively from left to right

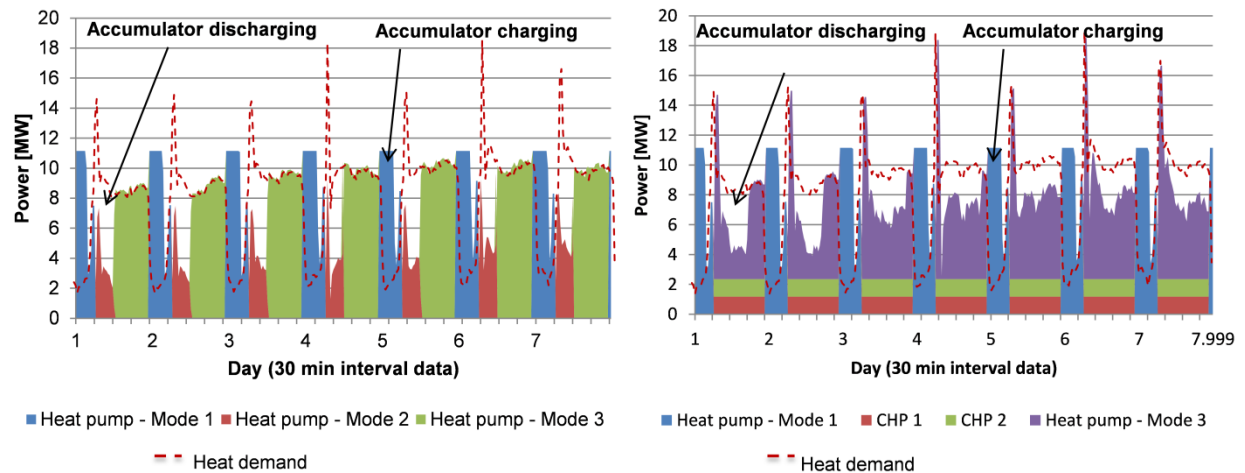

Figure 7 Scenario 2 (on the left) and 3 (on the right) heat generation and demand from the 11th to the 17th of January

3.2 Financial analysis

The annual heat cost for the current operation was calculated to be of £1,361,025 in 2012. This heat cost was calculated from adding to the energy costs, the maintenance cost of the CHP engines and assuming the import and export electricity cost to be similar. The heat cost for scenario 1, 2 and 3 was carried out similarly, but also added the loan for purchasing the new CHP engines or heat pump. From Table, it can be noticed that scenario 1 leads to some heating cost savings, whereas scenario 2 and 3, with the purchase of a heat pump, have a higher heating cost. However, these later scenarios are not necessarily less attractive than scenario 1. Firstly, the lifespan of the heat pumps is longer than the CHP engines (at least 30 years compared to approximately 15 years for the CHP engines). Therefore, the repayment for the purchase of the heat pump could be changed from 10

years to 20 years, which would reduce the heating cost loss to ~£100,000 per year for Scenario 2. Secondly, due to the high capital cost of the heat pump, scenario 2 and 3 are also very sensitive to the loan interest rate and if this later is reduced from the original 7% to 4%, a heating cost saving of ~£7,000 per year would then be achieved. Thirdly, more savings can be achieved from operating the current CHP engines in conjunction with the heat pump; comparing Scenario 2 to 3, it can be appreciated that operating the CHP engines reduces the heat cost loss of ~£85,000. Furthermore, to operate the CHP engines would save more than that because the heat pump could during the day consume directly the electricity generated from the CHP engines while benefiting by having to import and export less electricity at high and low rates respectively. Finally, the operation of a heat pump would also benefit from the Renewable Heat Incentive (RHI), which would give a fixed income of 0.035 £/kWh for every kWh of produced heat [5].

Table 2: Financial analysis

	Electricity or supplementary electricity consumption				Natural gas	Maintenance cost		Heat cost	
	Heat pump	DHN	River pumping	Boilers and CHP engines	Savings	CHP	Heat pump	Savings	Reduction
	k£	k£	k£	k£	k£	k£	k£	k£	%
Current operation	--	32	--	19	1,861	91	--	0	0
Scenario 1	--	32	--	31	2,947	336	--	82 to 120	6.0 to 8.8
Scenario 2	823	37	3	--	--	--	78	-348	-26%
Scenario 3	621	37	25	8	802	110	78	-260	-19%

3.3 CO₂ emission analysis

Table compares each scenario's CO₂ emission to the baseline. In 2012 the current operation reduced by 8% the equivalent CO₂ emissions, while operating its two 1.6 MWe CHP engines. Although Scenario 2 consumes the least source energy, it is not the scenario minimising the CO₂ emission, because heat pumps operate consuming electricity from the national grid and the grid carbon factor in the UK is high compared to the natural gas carbon factor. However, in the near future the national grid carbon factor is likely to reduce and when this factor reaches 0.4 kg/kWh, a heat pump operating with a COP of approximately 3 becomes more attractive in terms of CO₂ emissions than operating a CHP engine.

Table 3: CO₂ emission analysis

	Traditional system - Baseline			Site's operation			Equiva- lent CO ₂ emission reduction
	Heating load	Electricity load	Equival- ent CO ₂ emission	CO ₂ emission	Cons- umed natural gas	Cons- umed electricity	
	MWh	MWh	Tonne CO ₂	Tonne CO ₂	Tonne CO ₂	Tonne CO ₂	
Current operation	47,132	10,352	16,493	15,167	14,739	428	8.0
Scenario 1	47,132	41,917	32,650	23,861	23,338	522	26.9
Scenario 2	47,132	--	10,979	9,646	--	9,646	12.1
Scenario 3	47,132	12,833	17,614	14,209	6,352	7,856	19.3

3.4 Exergy analysis

The exergy breakdown losses for every scenario are given in Table. From this table, it can be noticed that in the current operation, most of the exergy losses happen in the energy plant when converting the natural gas into heat and electricity. For this reason, scenario 1 looked into financially optimising the use of new gas fired CHP engines and its overall exergy efficiency improved from 21.3 to 45%. Scenario 2 looked into assessing the exergy efficiency of the site while operating a high temperature open-loop heat pump. Although the overall exergy efficiency of operating such a system reduces compared to Scenario 1, the EC exergy efficiency are approximately equal. The overall exergy efficiency reduces because, as shown in the exergy flow and loss diagram given in Figure 8, the initial exergy is considerably reduced in Scenario 2 and the percentage of exergy losses to convert the heat exergy into space heating (SH) and domestic hot water (DHW) increases. Hence, if Scenario 2 or 3 is adopted, the next exercise should be to optimise the overall exergy efficiency by reducing the exergy losses associated with the DHW and SH provision. This could be done by reducing the DH return temperature, this could be achieved by exchanging the current calorifiers with flat plate heat exchangers and replacing the radiator heating with under floor heating. This would also allow a lower supply temperature that would improve the COP of the heat pump; hence it would also improve the exergy and energy efficiency of the EC.

Table 4: Exergy analysis

	Exergy consumed				Exergy loss				Overall exergy efficiency %
	Initial exergy	Electricity	DHW	SH	Energy centre	DHN	DHW	SH	
	MWh	MWh	MWh	MWh	MWh	MWh	MWh	MWh	
Current operation	70,240	10,352	3,233	1,411	49,887	918	855	3,585	21.3
Scenario 1	103,528	41,917	3,233	1,411	51,609	918	855	3,585	45.0
Scenario 2	18,658	--	3,233	1,411	9,096	1,028	607	3,283	24.9
Scenario 3	45,112	12,833	3,233	1,411	22,718	1,028	607	3,283	38.7

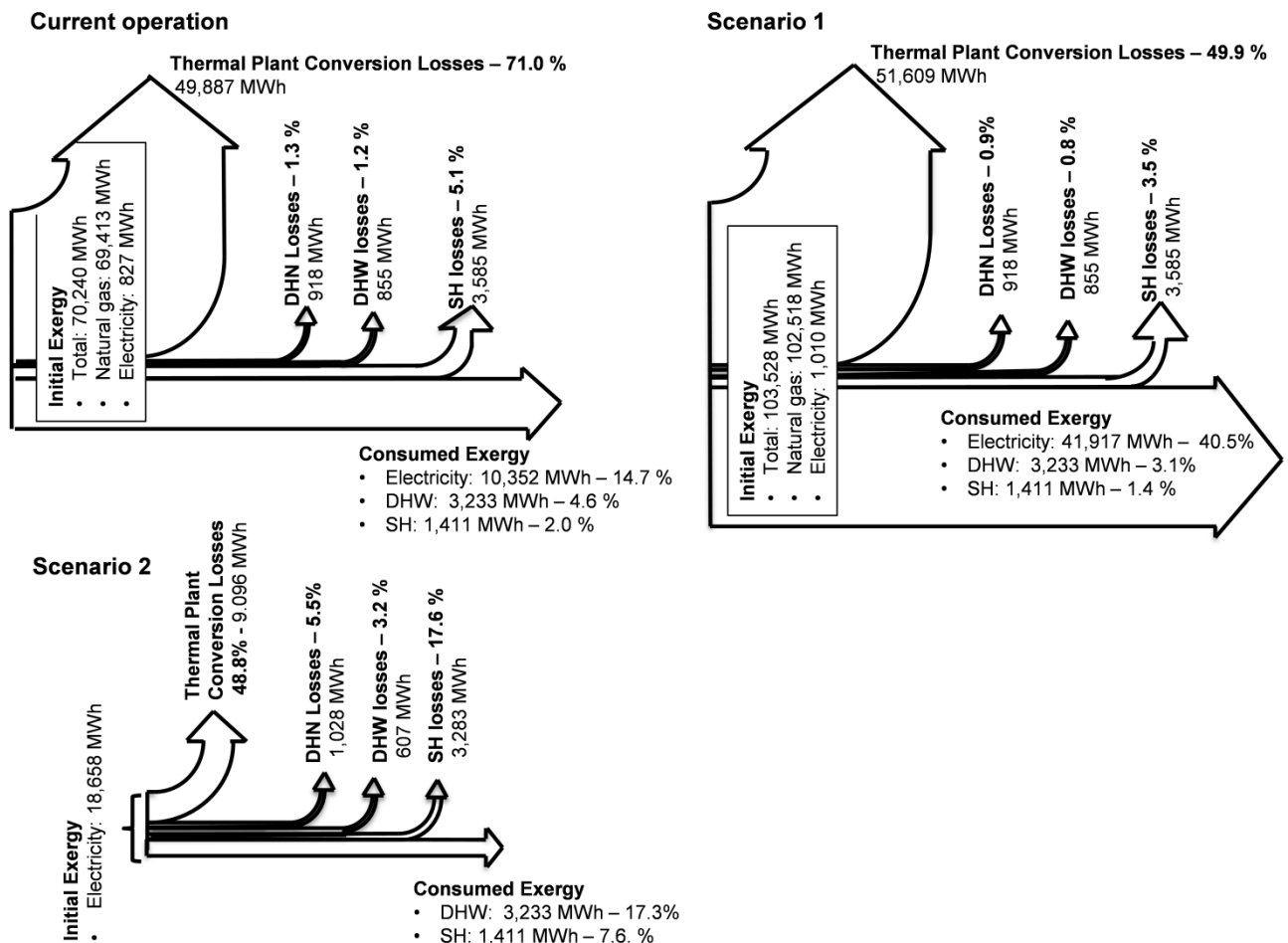
Figure 8: Grassmann (Exergy flow and loss) diagram for the Current operation of the plant (top left), Scenario 1 (top right) and Scenario 2 (bottom left)

4 Conclusion

The current cogeneration plant of Pimlico DH system operates while distributing a resilient heating load to every consumer. Its current operation was compared to different scenarios that each showed interesting benefits. Scenario 1 minimises the heating cost by reducing it by approximately £100,000, while also minimising the CO₂ emissions. Scenario 2 operates with a single renewable technology; a heat pump. Hence, it will benefit from renewable energy incentives and consume a reduced amount of energy. This reduced energy consumption contributes to minimising the CO₂ emission of the plant that will also benefit from decarbonising the national grid. Scenario 3 is a good compromise to benefit from today's renewable energy incentives, and from CHP engines currently being more economical and achieving lower CO₂ emissions. Hence, adopting Scenario 3 will provide sufficient adaptability to comply with future policy requirements which will require heating load to be carbon neutral. Scenario 2 and 3 may obtain a greater heating cost saving if i) the repayment of the heat pump is considered to be over 20 years ii) a lower interest rate than the assumed 7% is achieved for the repayment loan of the heat pump iii) consuming the generated electricity from the CHP engine reducing import and export of electricity at a high and low rates respectively. And finally, operating a heat pump would benefit from the RHI.

The exergy analysis of the current operation showed that 71% of exergy losses took place for the energy conversion within the energy plant. Hence, Scenario 1 optimised financially the operation of the EC by adding increased CHP capacity, which, as shown in the Grassmann diagram (Figure 8), also reduces the exergy losses from the EC. This diagram also showed that no more optimisation work could then be applied to improve the exergy efficiency. Scenario 2 analysed the operation of the site when operating a high temperature heat pump which obtains for the EC a similar exergy efficiency than in Scenario 1, but with a reduced overall exergy efficiency of the DH. If Scenario 2 or 3 is adopted, further work will be necessary to minimise the exergy losses from the DHN and converting the heat-exergy to DHW and SH. This would increase the overall exergy efficiency of the system and reduce further the heating cost.

Finally, Scenario 2 showed that the selected heat pump, with a lower heat capacity of 14 MW on its own in winter could meet with the accumulator the heating demand. Although the morning heating peak demand can reach approximately 20 MW, this heat pump with a lower capacity can meet this demand, because operating the heat pump in Mode 2 upgrades already produced and stored heat at 75°C. Hence, having storage gives the site the possibility to supply over 20 MW of heat to the DHN, while having a heat pump of less than 14 MW capacity in winter.

Reference list

- [1] Greater London Authority, 2010. Delivering London's Energy Future, London: GLA.
- [2] Borel, L., Favrat, D., 2010, Thermodynamics and Energy Systems Analysis: From Energy to Exergy. Lausanne: EPFL Press, First Edition.
- [3] Favrat, D., Marechal, F., Epelly, O., The challenge of introducing an exergy indicator in a law on energy, Energy, 33(2), pp.130-136.
- [4] DECC, 2009. *The Government's standard Assessment Procedure for Energy Rating of Dwellings*. 9.90. Garston, Watford WD25 9XX: BRE.
- [5] RHI. 2011. Tariff level tables, Renewable Heat Incentive, <http://www.rh incentive.co.uk/> [27/08/2013]

APPENDIX E DISTRICT HEATING OPTIMISATION (PAPER 5)

Full Reference

Martin-Du Pan, O., Eames, P., Rowley, P., Bouchlaghem, D., Susman, G., 2014. District heating optimisation. The 14th international symposium on district heating and cooling. DHC+ technology platform. 7-9 September 2014: Stockholm.

Abstract

This paper proposes a new methodology for optimising a DH system. It optimises the system in a cost effective and resource efficient way, while maximising every coefficient of performance and reducing CO₂ emissions. The optimisation method was simulated using Pimlico District Heating Undertaking as a case study. PDHU is a 50,000 MWh district heating generating heat with two gas fired 1.6 MWe CHP engines and three 8 MWth boilers. The current operation was compared to two optimised Strategies which were simulated. Strategy 1 operates with greater CHP engines and Strategy 2 with an open loop heat pump.

1 Introduction

A district heating scheme distributes heat from a centralised location to serve residential and commercial heating requirements. This heat can be generated or captured from a variety of sources. The aim of a district heating system is to supply heat to consumers in a cost effective and resource efficient way. The efficient use of resources addresses the three energy challenges that the UK faces: Climate change, fuel poverty and energy security. The four components as well as the overall operation of a DH system can be optimised by minimising thermal losses and CO₂ emissions for a given resource input. These four components are:

- **The power plant** (or supply units) – A DH power plant can operate in heating mode only or in cogeneration, powered by any type of resources: Industrial excess heat, energy from waste, renewable energy, electricity, fossil fuel or nuclear.
- **The district heating network** - The heat from the energy centre is pumped through the district heating network to the consumer substations. Some electricity is consumed and some heat is lost to the soil environment.
- **Consumer substation** – Consumers can have their space heating directly connected to the district heating network (DHN), but are usually connected indirectly. The indirect connection is done with the use of a heat exchanger. The domestic hot water is always connected with a heat exchanger.

- **Consumer** – Heat is consumed for space heating and/or the domestic heat water (DHW) in residential, office and industrial buildings. An industrial building may also consume heat for low temperature industrial processes such as drying.

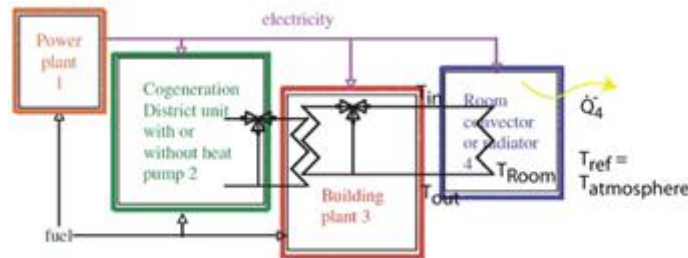

Figure 1 District heating system and its system components boundaries (Borel and Favrat, 2010)

This optimisation paper uses Pimlico District Heating Undertaking (PDHU) as case study to illustrate the optimisation guideline from Section 2. PDHU is a 50,000 MWh DH system located in Pimlico, central London. It includes two 1.6 MWe CHP engines used as the lead heat source during the day tariff and three 8 MWth boilers and a 2,500 m³ accumulator. A network of insulated pipes transports the heat from the energy plant to 3,256 consumers and 55 commercial units.

2 Proposed Optimisation Method

DH could be optimised by improving the three following parameters: i) The COP of each component, ii) The possible overall exergy efficiency and iii) The CO₂ reduction. Exergy is defined as the potential of maximum work which can be obtained by each energy unit linked to the DH system (Borel and Favrat, 2010). The proposed method is to optimise a DH in respect to these three parameters. This can be done following the below steps:

- 1) Map out the components in the DH and calculate the seasonal energy flows (this is usefully visualised in a Sankey diagram).
- 2) Calculate the exergy flows and loss of each component (this is usefully visualised in a Grassmann diagram).
- 3) Look at the energy and exergy operating efficiencies of the four components.
- 4) Determine the potential energy and exergy efficiencies for each component.
- 5) Calculate the potential energy savings and the potential exergy conversion percentage savings.
- 6) Calculate the CO₂ emissions of the DH and compare with the national grid decarbonisation plan.

The use of a table summarising all these results can help to assess and analyse the benefit of adopting any new strategy. As exergy efficiencies are never bigger than 100%, the

exergy conversion losses for each component of the DH can be given in percentage terms and compared to the total initial consumed exergy. Furthermore, the exergy analysis benefits from also including the consumptions of all supplementary electricity. The successive exergy flow values given in the Grassmann diagram indicate the exergy destruction by each component of the DH system. As exergy is not an energy loss but energy destruction, reducing the exergy loss in one component of the DH system does not necessarily improve its energy efficiency. That said, generating heat at a lower supply temperature reduces the space heating exergy conversion loss and may simultaneously improve the COP of the plant. This can happen if the plant generates heat with the use of a heat pump or following a Rankine or a similar cycle, thereby generating electricity simultaneously.

1 Energy flow and loss – The Sankey diagram

A Sankey diagram illustrates the energy flows and losses from a DH system. The operating performance of each component in a DH system can then be calculated.

2 Exergy flow and loss - The Grassmann diagram

A Grassmann (Exergy flow and loss) diagram shows the ratio between the initial exergy consumed by the DH system and the final exergy consumed. The Grassmann diagram is a good indicator of the quality of the operation of a DH system; it shows the consecutive exergy losses from each component of the DH system. As exergy efficiency also includes supplementary electricity and is always smaller than 100%, every exergy loss can be directly compared to the initial exergy consumed. An exergy loss breakdown in percentage term is then obtained for each component. This is used to prioritise the optimisation of the DH system.

2.1.1 The coefficient of Performance

The coefficient of performance for each individual component shown in Figure 1 is the ratio of work or useful energy output to the amount of energy input. For an electrically driven heat pump, the COP is the ratio of heat provided to the electrical energy consumed. For a CHP engine or another technology consuming a heating fuel, the COP is the ratio of electricity and/or heat to the primary fuel energy.

2.1.2 The CO₂ Emissions

Figure 2 illustrates the CO₂ emissions associated with a DH system and a traditional system. By determining the CO₂ emissions for both options it is possible to calculate the CO₂ reduction against the UK baseline. The UK baseline assumes heat is generated with the use of an individual natural gas boiler operating with a seasonal efficiency of 85% and the electricity is provided by the Grid. According to the Standard Assessment Procedure guidance

document, the natural gas and the national grid electricity have an intensity factor of 0.217 and 0.519 kg CO₂/kWh respectively (DECC, 2013).

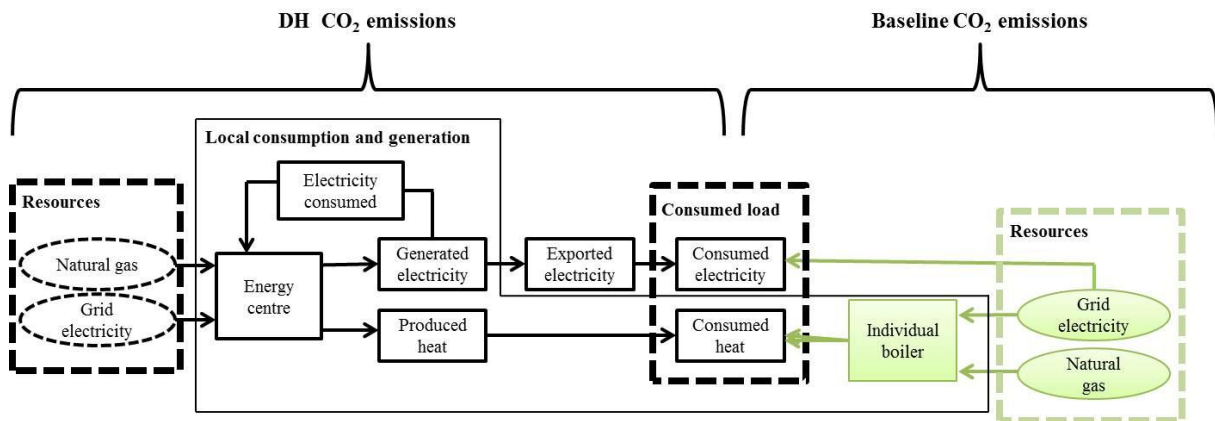

Figure 2 DH system CO₂ emission compared to the UK baseline

2.1.3 Exergy Efficiency Analysis

Exergy is defined as the potential of maximum work which can ideally be obtained from each energy unit and system (Borel and Favrat, 2010). According to Favrat (2010) the exergy calculation approach quantifies in a coherent way, both the quantity and the quality of the different forms of energy under consideration. Compared to other efficiency definitions, the exergetic efficiencies are never bigger than 100% and are compatible with all cases of energy conversions and for all energy services. It indicates the relative quality of the conversion and therefore the characteristics of different technologies can be easily compared.

Assuming an atmospheric temperature of 5°C, the overall exergy efficiency of a defined system can be calculated using the following definition Equation (1), where η is the exergy efficiency, \dot{E} is the mechanical and electrical work, \dot{E}_q is the heat exergy and \dot{E}_y is the transformation exergy.

$$\eta = \frac{\sum \dot{E}^- + \sum \dot{E}_q^- + \sum \dot{E}_y^-}{\sum \dot{E}^+ + \sum \dot{E}_q^+ + \sum \dot{E}_y^+} \quad (1)$$

In this equation, all terms are positive, differencing between the terms entering the system with “+” sign and the positive terms (services) delivered by the system with a “-“ sign.

Exergy calculation and example:

➤ **The heat exergy**

\dot{E}_q represents the heat exergy and can be calculated with Equation (2).

$$\dot{E}_q^+ = \int \theta \delta \dot{Q}^+ = \int \left(1 - \frac{T_a}{T}\right) \delta \dot{Q}^+ \quad (2)$$

θ is the Carnot Factor and is equal to $\left(1 - \frac{T_a}{T}\right)$ and \dot{Q} is the rate of heat transfer.

Thus, the exergy demand for the space heating (SH) and the domestic hot water (DHW) can be calculated using Equation (3).

$$\dot{E}_q^- = \dot{Q}^- \left(1 - \frac{T_a}{T_{Room\ or\ DHW}}\right) \quad (3)$$

Example:

If a daily building demands 100 MWh of heat and is heated at 21°C against an outside temperature of the assumed average of 5°C. The heat exergy is calculated with Equation (a) according to Equation (3).

$$\dot{E}_q^- = \dot{Q}^- \left(1 - \frac{T_a}{T_{Room\ or\ DHW}}\right) = 100 * \left(1 - \frac{278}{294}\right) = 5.4\ MWh \quad (a)$$

➤ The transformation exergy

The transformation exergy \dot{E}_y^+ groups the transformation exergy of material flows entering or leaving the system. This term links the network of fluids which come into direct contact with each other such as in a heat exchanger. A heat exchanger links two heating flow; thus two individual transformation exergy is calculated. The transformation exergy of fluid cooling or heating in a heat exchanger can be calculated with Equation (4).

$$\dot{E}_{y4}^+ = \dot{Q}^+ \left(1 - \frac{T_a}{\hat{T}_{ln\ fluid}}\right) \quad (4)$$

With $\hat{T}_{ln\ fluid} = \frac{T_{out} - T_{in}}{\ln\left(\frac{T_{in}}{T_{out}}\right)}$ in Kelvin.

Example:

If a fluid exchanges 100 MWh of heat in a heat exchanger while cooling from 90°C to 60°C, the heat exergy exchanged is calculated in Equation (b) using Equation (4). The outside temperature is assumed to be at 5°C.

$$\dot{E}_{y4}^+ = \dot{Q}^+ \left(1 - \frac{T_a}{\hat{T}_{\ln fluid}} \right) = 100 * \left(1 - \frac{278}{348} \right) = 20.1 \text{ MWh} \quad (b)$$

$$\text{With } \hat{T}_{\ln fluid} = \frac{333-363}{\ln\left(\frac{363}{333}\right)} = 348 \text{ K}$$

3 Application of the Proposed Methodology

3.1 Current operation of Pimlico District Heating Undertaking

Currently, the thermal storage is used to balance the heating load and to operate the CHP engines at full load. With annual half hourly data, the annual daily heat generation from each respective supply unit was undertaken and is given in Figure 3.

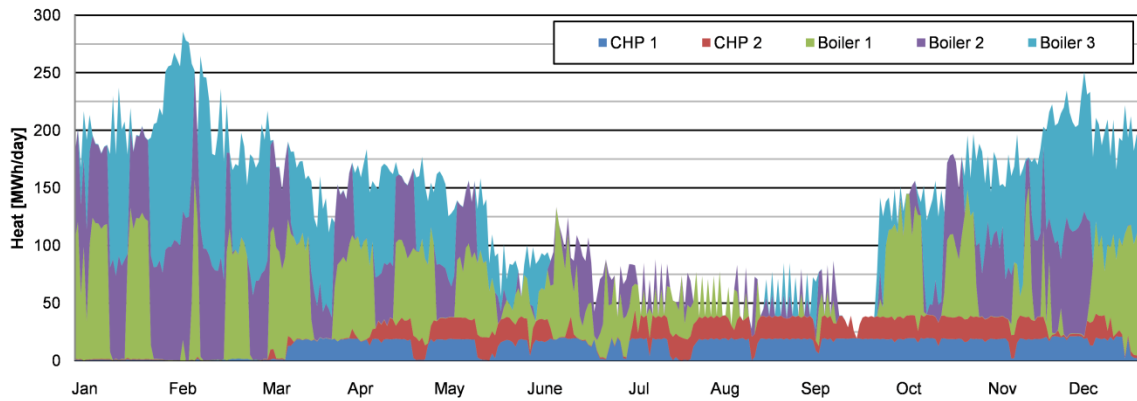

Figure 3 Annual daily heat demand at PDHU

3.1.1 Energy, Exergy and CO2 Emissions Assessments

On the left side of Figure 4 is an energy flow diagram and on the right side is an exergy flow diagram that was built while assuming an outside temperature of 5°C.

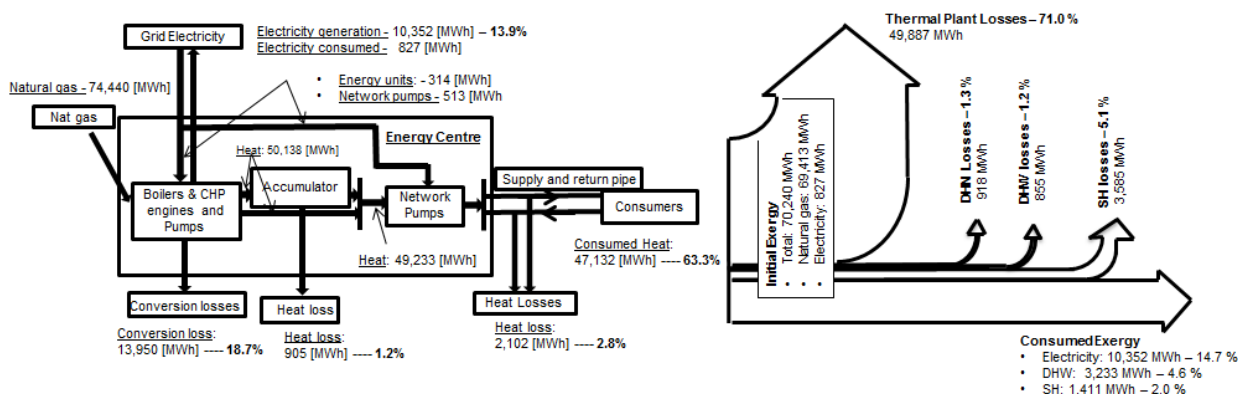

Figure 4 On the left is the current operation energy flow with a Grassmann diagram on the right

Table 1 gives the distribution of energy losses. It also quantifies the potential energy savings that could be overcome while keeping the similar DHN configuration, the consumers' DHW temperature at 55°C and the same DH flow return temperature at 61.5°C. Table 1 also quantifies the distribution of exergy losses. As CHP engines operate with a greater exergy efficiency than boilers, the potential exergy saving was calculated against the plant generating 100% of its heating load with the use of greater CHP engines.

Table 2 gives the CO₂ emissions from the current operation of the plant. After comparing it against the UK baseline, it was calculated that the CO₂ emissions of the current operation of the plant are 4.8% lower.

Table 1: Maximum energy and exergy savings possible and CO₂ savings

	Energy centre	Accumulator	DHN	Sub-station	DHW conversion	SH conversion
Thermal loss [MWh]	13,950	905	2,102	--	0	0
Operating COP [%]	Boiler: 83% CHP: 78%	94.3	95.7	--	100	100
Max operating COP [%]	Boiler: 91% CHP: 78%	100	100	--	100	100
Potential energy saving [MWh]	Boiler: 3,645 CHP: ~ 0	905	2,102	--	0	0
Overall thermal efficiency: 77% (excluding supplementary electricity).						
Exergy conversion loss [MWh]	49,887		918	--	855	3,585
Exergy efficiency [%]	28.5		90.8	--	79.1	28.2
Max exergy efficiency [%]	55.0		94.7	--	85.9	30.7
Potential exergy percentage saving	26.3 %		0.5 %	--	0.4 %	0.2 %
Overall exergy efficiency: 21% (including supplementary electricity).						

Table 2: Current CO₂ emission

	CO ₂ emissions			
	Current operation		Optimised operation*	
	Current CO ₂ emission factors: kg/kWh <i>Nat gas: 0.216</i> <i>Electricity: 0.519</i>	Future CO ₂ emission factor: kg/kWh <i>Nat gas: 0.216</i> <i>Electricity: 0.4 kg</i>	Current CO ₂ emission factors kg/kWh <i>Nat gas: 0.216</i> <i>Electricity: 0.519</i>	Future CO ₂ emission factor: kg/kWh <i>Nat gas: 0.216</i> <i>Electricity: 0.4</i>
CO ₂ emission [tonne CO ₂ /year]	16,508	16,410	32,965	32,829
Baseline [tonne CO ₂ /year]	17,350	16,118	47,093	39,041
CO ₂ emission reduction [%]	4.8	-2	30	16

*The optimised operation assumes that CHP engines supplies the complete heating load

3.1.2 Analysis

Energy

From Table 1, it can be noted that the boilers operate with a poor seasonal efficiency; by setting the boilers to operate full load and restricting their on/off operation, the boilers could operate at maximum efficiency and this would save 3,645 MWh of heat per year. As the energy plant benefits from a 2,500 m³ accumulator, this new setting can and should be applied as a priority.

Exergy

In the current operation, the CHP engines are undersized. The potential maximum exergy saving that could be obtained by installing larger CHP engines could be approximately 26%.

CO₂ emissions

As the carbon intensity factor from the national grid is planned to reduce in the future, the current CO₂ emissions reduction of 4.8% was compared to using a reduced electricity carbon factor of 0.4 kg CO₂/kWh. This new carbon factor would mean a 2% increase in the CO₂ emissions against the current baseline.

The current operation of the plant was then compared to the maximum CO₂ emissions savings that could be obtained if 100% of the heat was generated by CHP engines and this would result in a 30% reduction in CO₂ emissions. However, this CO₂ emissions reduction would be smaller with the decarbonisation of the Grid in the future. If the national grid carbon factor equals 0.4 kg/kWh, it would mean a 16% CO₂ reduction from this lower carbonised UK baseline.

3.2 Strategy 1

Strategy 1 assumes the plant to operate with larger CHP engines and the current boilers to operate at maximum efficiency. A previous study calculated that a 8.8 MWe total CHP engine capacity would minimise the heating cost. To maximise the COP, the boilers are set to operate full load for a minimum of four hours. This would set them to only operate at their maximum efficiency of 91%, based on the HHV.

3.2.1 Energy, exergy and CO₂ emissions assessments

Figure 5 is similar to the Figure in Section 3.1.1. On the left side is an energy flow diagram and on the right side is an exergy flow diagram that was built while assuming an outside temperature of 5°C.

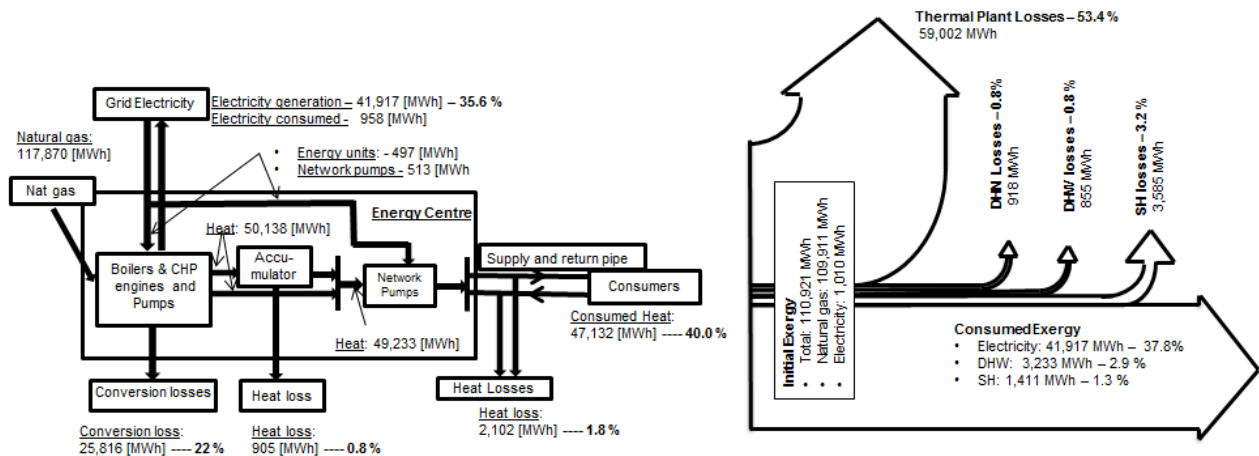

Figure 5 On the left is Strategy 1 energy flow with a Grassmann diagram on the right

Table 3 is similar to Table 1. It gives the energy losses distribution for Strategy 1. It quantifies the potential energy savings that could be obtained while keeping the similar DHN configuration, the consumers' DHW temperature at 55°C and the DH flow return temperature at 61.5°C. Table 3 also quantifies the distribution of exergy losses. As this Strategy also operates with the use of gas fired boilers and CHP engines, their operating maximum exergy efficiency is similar to the one in Table 1: It simulates that there are greater CHP engines to generate 100% of the heating load.

Table 4 gives the plant CO₂ emissions for this strategy. With the current carbon intensity factors and compared to the Baseline, it was calculated that Strategy 1 reduces the CO₂ emissions by 23%.

Table 3: Energy and exergy losses distribution for Strategy 1

	Energy centre	Accumulator	DHN	Substation	DHW conversion	SH conversion
Thermal loss [MWh]	25,815	905	2,102	--	0	0
Operating COP [%]	Boiler: 83% CHP: 78%	94.3	95.7	--	100	100
Max operating COP [%]	Boiler: 91% CHP: 78%	100	100	--	100	100
Potential energy saving [MWh]	Boiler: 0 CHP: ~ 0	905	2,102	--	0	0
Overall thermal efficiency: 75.5% (excluding supplementary electricity).						
Exergy conversion loss [MWh]	59,002		918	--	855	3,585
Exergy efficiency [%]	46.6		90.8	--	79.1	28.2
Max exergy efficiency [%]	55.0		95.7	--	85.9	30.7
Potential exergy percentage saving [%]	8.4 %		0.3 %	--	0.3 %	0.1 %
Overall exergy efficiency: 42% (including supplementary electricity).						

Table 4: Strategy 1 CO₂ emissions

	CO ₂ emissions			
	Strategy 1 operation		Optimised operation*	
	Current CO ₂ emission factors: kg/kWh <i>Nat gas: 0.216</i> <i>Electricity: 0.519</i>	Future CO ₂ emission factor: kg/kWh <i>Nat gas: 0.216</i> <i>Electricity: 0.4 kg</i>	Current CO ₂ emission factors kg/kWh <i>Nat gas: 0.216</i> <i>Electricity: 0.519</i>	Future CO ₂ emission factor: kg/kWh <i>Nat gas: 0.216</i> <i>Electricity: 0.4</i>
CO ₂ emission [tonne CO ₂ /year]	25,984	25,864	32,965	32,829
Baseline [tonne CO ₂ /year]	33,732	28,744	47,421	39,294
CO ₂ emission reduction [%]	23	10	30	16

*The optimised operation assumes that CHP engines supplies the total heating load.

3.2.1 Analysis

Energy

From Table 3, it can be noted that apart from better insulating the thermal storage and the DHN, more energy savings cannot be obtained from the DH system. However, from a previous study, it is known that the thermal storage operates with a 93% seasonal efficiency and less than 5% of the supplied heat is lost to the soil. Hence, it is concluded that there is no need to further minimise these heat losses.

Exergy

With these larger CHP engines, the exergy efficiency of the energy plant improved considerably and calculated to be 47%. A larger CHP engine capacity could potentially improve this efficiency further to 55%, but would not be financially attractive to do so.

CO₂ emissions

The CO₂ emissions reduction of this strategy is of 23%. However, when the electricity carbon factor reduces to 0.4 kg/kWh, the CO₂ emission reduction would reduce to 10%.

3.3 Strategy 2: Heat pump

As no more major economic optimisation can result from PDHU while operating under gas fired CHP engines and boilers, Strategy 1 is compared to a Strategy that operates the plant with a single open-loop heat pump. Although the morning peak load demand may equal 24 MWth, a single heat pump ranging between 10.5 MWth and 15 MWth capacity, depending on the river temperature, could meet the punctual and daily heating load along with using thermal storage.

Operation of the heat pump

As Strategy 2 assumes the similar DHN configuration and the similar DH average return temperature of 61.5°C as the current operation, the heat pump is set to operate with these constraints. To operate the heat pump with a better COP, the minimum flow rate from the power station is of 100 kg/s, which means the supply temperature is controlled to meet the heating demand. Hence, this Strategy pumps more water through the DHN so this additional electricity consumption was calculated using the equation from the interpolation curve given in Figure 6. This Figure was obtained from a former study and is the electricity consumed at PDHU to pump varying flow rates through its DHN. Thus, this Strategy consumes 691 MWhe of electricity to pump the annual heating load through the DHN. As the average supply temperature is reduced compared to the current operation of the plant, the heat losses to the soil by this strategy are also reduced and was calculated to be of 1,806 MWh.

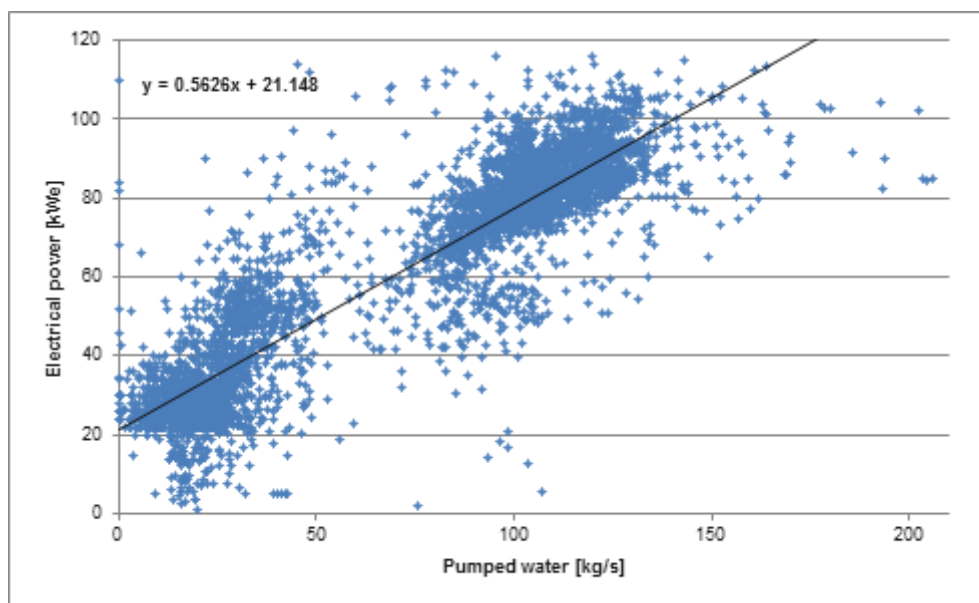

Figure 6 Electrical power to pump a known amount of water through the DHN

As a heat pump COP reduces when upgrading the inflow at higher temperatures, the heat pump was set to operate at three different Modes:

- Mode 1: It increases the return DH water from 60°C to 75°C
- Mode 2: It increases the stored heat from the accumulator from 75°C to 90°C
- Mode 3: It increases the return DH water from 60°C up to 90°C

Mode 1 operates at night to supply the night heating load and to charge the thermal storage with hot water to 75°C. If necessary, Mode 2 operates in priority during the day to supply the daily and the morning heat peak demand. Increasing the supply temperature with Mode 2 avoids increasing the DH flow rate. Mode 3 operates when no more heat is stored in the thermal storage.

This open loop heat pump requires some power to pump the water from the river to its evaporator. The power to overcome the maximum pressure drop at the evaporator of the heat pump is known to be 56kW. Assuming a 500 mm diameter pipe, a trajectory of 50 m, two 90° elbows and 10 m level difference, the maximum pressure drop to pump the river water to the accumulator was also calculated. As this water is pumped with the use of an electric pump operating with an assumed 75% efficiency, the annual electrical power consumption was calculated to equal 793 MWh per year.

3.3.1 Energy, exergy and CO₂ emissions assessments

Figure 7 is similar to the Figure in Section 3.1.1. On the left side is an energy flow diagram and on the right side is an exergy flow diagram that was built while assuming an outside temperature of 5°C.

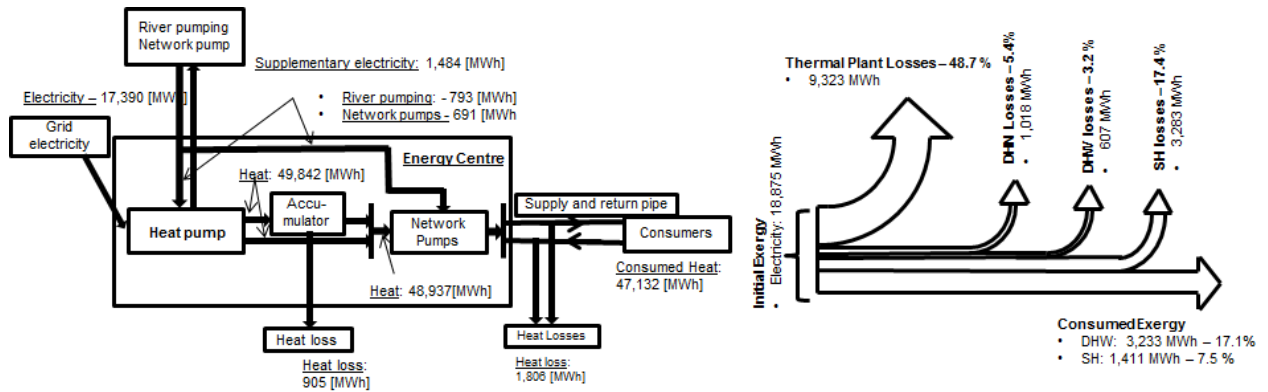

Figure 7 On the left is strategy 2 energy flow with a Grassmann diagram on the right

Table 5 gives the energy losses distribution. It quantifies the potential energy savings while keeping the similar DHN configuration, the consumer's DHW temperature at 55°C and the DH return temperature at approximately 61.5°C. This Table also quantifies the distribution of exergy losses. The maximum energy and exergy efficiency assumes that the maximum supply temperature is equal to 75°C and that the heat pump operates at Mode 1 only. The maximum CO₂ reduction is also calculated assuming the heat pump to only operate with Mode 1, see Table 6.

Table 5: Strategy 2 energy and exergy losses distribution

	Energy centre	Accumulator	DHN	Substation	DHW conversion	SH conversion
Thermal loss [MWh]	--	905	1,806	--	0	0
Operating COP (incl. river pumping) [%]	287	94.3	96.3	--	100	100
Max operating COP [%]	300	100	100	--	100	100
Potential energy saving [MWh]	776	905	1,806	--	0	0
	Overall energy efficiency: 271% (excluding supplementary electricity and heat from the river)					
Exergy conversion loss [MWh]	9,323		1,018	--	607	3,282
Exergy efficiency [%]	48.7		89.3	--	84.2	30.1
Max exergy efficiency [%]	50.7		92.5	--	89	31.8
Potential exergy percentage saving [%]	1.9%		1.6%	--	1.0%	0.4%
	Overall exergy efficiency: 24.6% (including supplementary electricity)					

Table 6: Strategy 2 CO₂ emissions

	CO ₂ emissions			
	Strategy 2 operation		Optimised operation*	
	Current CO ₂ emission factors: kg/kWh <i>Nat gas: 0.216</i> <i>Electricity: 0.519</i>	Future CO ₂ emission factor: kg/kWh <i>Nat gas: 0.216</i> <i>Electricity: 0.4 kg</i>	Current CO ₂ emission factors kg/kWh <i>Nat gas: 0.216</i> <i>Electricity: 0.519</i>	Future CO ₂ emission factor: kg/kWh <i>Nat gas: 0.216</i> <i>Electricity: 0.4</i>
CO ₂ emission [tonne CO ₂ /year]	9,796	7,550	8,906	6,863
Baseline [tonne CO ₂ /year]	11,977	11,977	11,977	11,977
CO ₂ emission reduction [%]	18	37	25.6	42.7

*The optimised operation assumes that the heat pump generates heat at 75°C only.

3.3.2 Analysis

Energy

The energy plant generates heat with an average and overall energy efficiency of 271%. If the heat pump was set to only operate at Mode 1, its electricity consumption would reduce by 5%.

Exergy

The exergy efficiency contrasts with the energy efficiency. The exergy efficiency is only 24.6%. While keeping the similar DHN and consumers' configuration, the exergy efficiency of the plant cannot be improved. However, by reducing the heating temperature in the buildings and by changing the current calorifiers with cross flow flat plate heat exchangers, the supply and return DH flow temperatures would simultaneously reduce. This would improve the exergy efficiency conversion from the DHN to the space heating and the domestic hot water. With both strategies, the heat pump could then upgrade the DH return flow to and from a lower temperature. This would improve the overall exergy efficiency and simultaneously improve the heat pump seasonal efficiency. Finally, reducing the supply and return temperature will also reduce on the heat losses from the thermal storage and the DHN.

CO₂ emissions

With the current CO₂ emission factors, Strategy 2 reduces the CO₂ emissions by 18%. However, in contrast to Strategy 1, the CO₂ emissions will continue to reduce with the decarbonisation of the national grid. When the national grid electricity factor reaches 0.4 kg CO₂/kWh, Strategy 2 will reduce the CO₂ emissions by 37%.

4 Conclusion and further work

This paper considers a DH system optimised when consuming resources in a cost effective way. It also proposes to optimise the exergy efficiency of the DH system. As exergy efficiency can only be optimised when all coefficients of performances are maximised, the proposed optimisation model must firstly optimise every coefficient of performance of the DH system. Operating the plant with maximised COP reduces both the CO₂ emissions and the operating cost. However, if the energy plant operates on 100% renewable energy, increasing the COP will no longer benefit the CO₂ emission of the plant.

Currently, the national CO₂ emission reduces with increasing exergy efficiency. However, as the national grid decarbonises, the CO₂ reduction will no longer be linked with the exergy efficiency of a DH system. Hence, as the national grid decarbonises, CO₂ emissions calculation will no longer be a good assessment of DH performance. For this reason, this paper proposes to assess and optimise a DH using the exergy efficiency, which is not influenced and reliant on any external factor. DH is a technology that is best assessed using a direct scientific approach, such as COP calculations and exergy analysis.

References

- Borel, L. and Favrat, D., 2010.** Thermodynamics and Energy Systems Analysis: From Energy to Exergy. Lausanne: EPFL Press, First Edition.
- DECC, 2013.** *The Government's standard Assessment Procedure for Energy Rating of Dwellings*. Watford WD25 9XX: BRE.
- Favrat, 2010.** The challenge of introducing an exergy indicator in a law on energy, *Energy*, 33(2), pp.130-136.