

BLDSC no:- DX 184284

LOUGHBOROUGH  
UNIVERSITY OF TECHNOLOGY  
LIBRARY

AUTHOR/FILING TITLE	
WILCOT, P	
ACCESSION/COPY NO.	
DX 94265	
VOL. NO.	CLASS MARK
	LOAN COPY
<del>28 JUN 1996</del>	
<del>28 JUN 1996</del>	
13 MAR 1997	

0400942658



THIS BOOK WAS BOUND  
BY ADMINTON PRESS  
TO THE HALCROFT  
SYSTEM  
LEICESTER LE7 6LD  
0533 602918



FUEL FROM STRAW:  
AN IN-FIELD BRIQUETTING PROCESS

by

PETER WILLMOT, B.Sc., C.Eng., M.I.E.D.

A Doctoral Thesis submitted in partial fulfilment of the requirements for the award of Doctor of Philosophy of the Loughborough University of Technology, October 1990.

© P. Willmot, 1990

Loughborough University of Technology Library	
Date	SEP 91
ACC No.	<del>0000000000</del> 040094265

59909456



PROTOTYPE STRAW BRIQUETTING MACHINE UNDERGOING FIELD TRIALS  
(Photograph by courtesy of British Sugar plc)

## ABSTRACT

Disposal of large quantities of surplus straw, which lie in the fields after harvest, is a major annual problem to cereal farmers. The current preferred solution of burning the straw where it lies is environmentally unsatisfactory and appears to be a huge waste of a potentially valuable, renewable energy source. None of the currently available straw packaging systems provides an economically viable alternative.

A process is proposed for producing industrial quality fuel briquettes using a tractor towed implement. The economic feasibility of such a system is investigated and comparisons are made with existing straw disposal methods. The projected cost of fuel, produced in this way, is compared with prevailing fossil fuel prices.

A multistage continuous process machine concept is described and the various stages are proven workable both experimentally, in the laboratory, and analytically. Laboratory experiments determine the forces required to produce acceptable quality briquettes and comparisons are made between the power available from the tractor, the economical throughput rate and the energy consumed in the compaction process.

The mechanism of bonding within the straw packages, under compression, is examined so that the parameters necessary to give the optimum machine design may be understood. The effect, on briquette quality, of variations in die shape within the constraints imposed by the machine concept is fully investigated. Experiments extend to compression at speeds representative of 'live' field operation and a die shape is developed which produces packages of consistently good durability.

Many of the design ideas put forward in this thesis have now been incorporated in an original prototype machine, built and successfully field-tested by the company who has supported this project and now holds the relevant patents.

## ACKNOWLEDGEMENTS

The author would like to express his indebtedness to the people and organisations who gave invaluable assistance and advice with this work, in particular:

To the two companies who sponsored the project, Howard Rotavators Ltd. (up to 1986) and British Sugar plc. (1986 on).

To Professor G.R. Wray, the Director of Research for introducing the topic and the original sponsors, for his enthusiasm for the subject and his help and encouragement.

To Professor R. Vitols, the project supervisor for making available his invention for the research for providing untiring support, friendship and technical guidance throughout.

To Mr J.E. Baker for his much valued contribution, particularly his organisational and administrative skills during the early part of the project and for his help with editing the written work.

To Richard Angrave, Gurnam Panesar and John Barker who were all employed for brief periods to assist with the experimental work.

Finally, to the many members of the Department of Mechanical Engineering's technical staff who made contributions to the work, large and small, and who's skills were very much appreciated.

To the loving memory  
of  
my Mother and Father,  
Olive and Jack Willmot.



## CONTENTS

	<u>Page No.</u>
Abstract	ii
Acknowledgements	iii
Declaration	iv
List of Figures	xiv
List of Graphs	xvi
List of Tables	xvii
List of Photographs	xix
<u>CHAPTER 1: INTRODUCTION</u>	1
1.1 POLITICAL AND ENVIRONMENTAL CONSIDERATIONS WHICH ESTABLISHED THE NEED FOR THE RESEARCH.	1
1.2 PROPOSAL FOR A SOLUTION BY MEANS OF TECHNOLOGICAL ADVANCES IN AGRICULTURAL MACHINERY	5
<u>CHAPTER 2: STRAW IN THE FIELD: A WASTE DISPOSAL             PROBLEM OR A USEFUL RESOURCE?</u>	8
2.1 INCORPORATION - (Ploughing in)	9
2.2 BUILDING MATERIALS	11
2.3 PAPER MAKING	11
2.4 ANIMAL FEED	13
2.5 HORTICULTURAL USES	14
2.6 PETRO-PRODUCTS	15
2.7 THATCHING	15
2.8 STRAW FOR FUEL	15
<u>CHAPTER 3: THE ECONOMIC ARGUMENT FOR PRODUCING BRIQUETTES             IN THE FIELD</u>	20
3.1 PROCESS SYNTHESIS	20
3.1.1 Static briquetting plants	20
3.1.2 Fully mobile briquetting machines	20

	<u>Page No.</u>
3.2 A NEW DIMENSION	28
3.3 MARKET POSSIBILITIES	29
3.4 THE COST OF STRAW ON THE FARM	32
3.4.1 The value of straw to the farmer	32
3.4.2 The cost of baling and handling	35
3.4.3 The cost of field briquetting and handling	36
3.5 THE COST OF PROCURING STRAW FOR INDUSTRIAL OR HORTICULTURAL FUEL.	38
3.5.1 Transport	38
3.5.2 Storage	40
3.5.3 Typical procurement costs	44
3.6 THE COST OF VERY HIGH DENSITY, EXTRUDED STRAW BRIQUETTES	45
3.7 COMPARING THE COSTS OF STRAW PRODUCTS WITH THOSE OF FOSSIL FUELS	48
3.7.1 Primary fuel costs	48
3.7.2 Capital and operational costs of boiler plant installations	50
3.7.3 Annual costs: typical example	53
3.8 VIABILITY	54
 <u>CHAPTER 4: TECHNOLOGICAL FOUNDATION FOR THE RESEARCH</u>	 55
4.1 SURVEY OF TECHNICAL LITERATURE AVAILABLE AT THE COMMENCEMENT OF THE STUDY	55
4.1.1 Extrusion through ring dies: forage crops	56
4.1.2 Extrusion through ring dies: straw	57
4.1.3 Compaction within closed cylinders: forage crops	58
4.1.4 Compaction within closed cylinders: straw	60

	<u>Page No.</u>
4.2 EARLY RESEARCH AT LOUGHBOROUGH	61
4.2.1 Broomhall's work	62
4.2.2 Undergraduate project	63
4.2.3 Staff contribution	63
4.3 PARALLEL RESEARCH	63
<u>CHAPTER 5: SPECIFICATION OF THE PROPOSED FIELD</u>	
<u>BRIQUETTING MACHINE</u>	66
5.1 PERFORMANCE	67
5.2 TARGET COST	68
5.3 SIZE AND WEIGHT	68
5.4 ENVIRONMENT AND USAGE	68
5.5 LIFE IN SERVICE	69
5.6 MAINTENANCE	69
5.7 COMPETITION	69
5.8 PRODUCTION QUANTITY	70
5.9 AESTHETICS APPEARANCE AND FINISH	70
5.10 ERGONOMICS	71
5.11 THE CUSTOMER	71
5.12 STORAGE CONDITIONS	71
5.13 SAFETY	72
5.14 POLITICAL AND SOCIAL IMPLICATIONS	72
<u>CHAPTER 6: MACHINE SYNTHESIS AND PRELIMINARY EXPERIMENTS</u>	74
6.1 PRINCIPLES OF COMPACTION	74
6.2 MACHINE CONCEPTS	75
6.2.1 The Radial Disc Compactor	75
6.2.2 The Conical Disc Compactor	77
6.2.3 Converging Slideways	78

	<u>Page No.</u>
6.3 EXPERIMENTAL EVALUATION OF THE CONCEPTS	80
6.3.1 Closed Cylindrical Die Experiment	80
6.3.2 Closed Rectangular Die Experiments	84
6.3.3 Shearing Experiments	86
6.3.4 Experimental Notes	90
6.3.5 Conclusions from the Experimental Evaluation	91
6.4 THE MULTISTAGE CONCEPT	92
6.4.1 The Pick-up	92
6.4.2 The Pre-compactor	93
6.4.3 The Final Stage Compactor	99
6.4.4 The Output Stage	99
6.4.5 Additional Features	99
6.5 CONCLUSIONS OF THE SOLUTION SYNTHESIS	100
6.5.1 Choice of Final Stage Compactor	101
6.5.2 Choice of Pre-compactor	102
 <u>CHAPTER 7: BIOMECHANIC RESEARCH</u>	 104
7.1 THE STRUCTURE OF STRAW	105
7.1.1 Visible Characteristics	105
7.1.2 Anatomy of the Culm	108
7.1.3 Chemical Composition	112
7.2 THE EFFECT OF PRESSURE ON THE MICRO-STRUCTURE	113
7.2.1 Dissection and Visual Examination of Formed Briquettes	114
7.2.2 Microscopic Examination of Straw taken from Briquettes	115
7.2.3 Individual Straws under Equivalent Loads	116
7.3 THE EFFECT OF ORIENTATION ON BRIQUETTE FORMATION	118
7.3.1 Experimentation	118
7.3.2 Implications for Field-Briquetting Machines	124

	<u>Page No.</u>
7.4 EXPERIMENTAL ANALYSIS BY SEPARATION	125
7.4.1 Mass Distribution of Botanical Components	125
7.4.2 Briquettes formed from Separated Components	125
7.4.3 The effect of Chopping the Straw	131
7.4.4 Time Dependency	134
7.5 THE RELATIONSHIP BETWEEN PRESSURE AND COMPRESSED DENSITY	136
7.6 ELASTICITY AND RELAXATION	139
<u>CHAPTER 8: RESEARCH INTO THE EFFECTS OF VARYING THE SHAPE AND DIMENSIONS OF THE DIES</u>	 148
8.1 PRINCIPLES AND PROCEDURES	148
8.1.1 Nomenclature	149
8.1.2 Nominal Parameters	151
8.2 DIE STEP DIMENSIONS	152
8.2.1 The Step Ratio Criterion	152
8.2.2 The Energy used in shearing	154
8.3 THE EFFECT OF VARYING BRIQUETTE SIZE ON ENERGY CONSUMPTION	154
8.4 THE EFFECTS OF VARYING DIE SHAPE	156
8.4.1 Quality Factors	156
8.4.2 Energy Factors	158
8.5 FURTHER EXPERIMENTAL RESEARCH WITH CHAMFERED DIES	161
8.5.1 Application of the Step Ratio Criterion to Chamfered Dies	161
8.5.2 Mathematical Optimisation	167
8.5.3 Tests with Die Shapes resulting from the Mathematical Optimisation	167
8.6 DIE DRAUGHT	170
8.7 DIE DESIGN RESULTING FROM A COMPILATION OF THE PRECEDING RESEARCH	173
8.7.1 Type 'G' Dies	173
8.7.2 Summary of the Effects of Die Shape	175

	<u>Page No.</u>
<u>CHAPTER 9: RESEARCH INTO THE EFFECTS OF MOISTURE</u>	183
9.1 EXPERIMENTAL METHODS AND PROCEDURES	183
9.1.1 Methods used for Quantitative Measurement	184
9.1.2 Experimental Details and Die Configurations	187
9.2 RESULTS.	189
9.2.1 Density and Durability.	189
9.2.2 The Relationship between Unit Density Bulk Density.	192
9.3 DISCUSSION AND ANALYSIS	193
 <u>CHAPTER 10: RESEARCH INTO THE EFFECTS OF HIGH VELOCITY LOADING</u>	 200
10.1 IMPACT LOADS	200
10.2 THE DESIGN OF LABORATORY EQUIPMENT TO REPRESENT FULL SPEED FIELD CONDITIONS	202
10.2.1 The Search for a suitable Power Source	203
10.2.2 Design of a Test Rig to suit the High Speed Press	208
10.3 EXPERIMENTATION	210
10.3.1 Initial Observations	211
10.3.2 Investigation into Inconsistent Load Curves	214
10.3.3 The Ejector Mechanism	216
10.4 INVESTIGATION OF THE PLANE OF WEAKNESS	217
10.4.1 The Pressure Distribution within the Briquette	218
10.4.2 Further Die Modifications	221
10.4.3 The Influence of "no-load" inertia on the Results	222
10.5 RESULTS	224
10.5.1 Peak Force variation with Velocity	224
10.5.2 Force, Displacement and Energy Consumption	225

	<u>Page No.</u>
10.5.3 The Force required to Pre-Compact the Charge	225
10.5.4 Durability	227
10.5.5 Variations in Relaxed Density with Time	227
10.6 CONCLUSIONS	230
<u>CHAPTER 11: THE PRE-COMPACTOR</u>	239
11.1 INVESTIGATION INTO FORCES AND STRAW DENSITY	240
11.1.1 Experimentation	240
11.1.2 Results	241
11.2 DESIGN FEATURES OF A BELT TYPE PRE-COMPACTOR	242
11.2.1 Rig Design	242
11.2.2 The Elimination of Drag	246
11.3 TESTING THE PRE-COMPACTOR RIG	247
11.3.1 Orientation, Density and Fibre Damage	247
11.3.1 Power Consumption	248
11.4 CONCLUSIONS	249
<u>CHAPTER 12: CONCLUSIONS AND RECOMMENDATIONS FOR FURTHER WORK</u>	253
12.1 SUMMARY OF RESEARCH	253
12.2 CONCLUSIONS	254
12.3 COMMENTS ON MACHINE DESIGN	257
12.4 SUMMARY OF STATISTICS	259
12.5 SUGGESTIONS FOR FURTHER WORK	260
12.5.1 Density Variations	260
12.5.2 The Rolling Action of the Die	261
12.5.3 Alternative Uses for the Compactor Technology	262

	<u>Page No.</u>
<u>APPENDIX I:</u> Supplementary Experimental Data.	263
<u>APPENDIX II:</u> The use of Numerical Analysis as an aid to Die Shape Optimisation.	269
<u>APPENDIX III:</u> Comparison of the Velocity Profiles of the Crank Press with Conical and Radial Disc Systems.	286
<u>APPENDIX IV:</u> Forces in the Second Stage Converging Chain System of the Precompactor Rig.	293
<u>APPENDIX V:</u> Analysis of the Separating Force acting on Radial and Conical Disc Compactors.	298
<u>REFERENCES</u>	311
<u>BIBLIOGRAPHY</u>	316

-ooo00ooo-



## LIST OF FIGURES

Figure No.	Title	Page No.
3.1.1a	Static Briquetting Plant; Process Flow Sheet	22/23
3.1.1b	Semi-mobile Briquetting Plant; Process Flow Sheet	24
3.1.2a	Mobile Briquetting Plant; Process Flow Sheet	25
6.2.1a	The Radial Disc Compactor Concept	76
6.2.2a	The Conical Disc Compactor Concept	77
6.2.3a	The Converging Slideway Concept	79
6.3.1a	Closed Cylinder Apparatus	81
6.3.1b	Typical Loading Curve for Straw Briquettes	83
6.3.3a	Shear Test Rig	87
6.4.2a	The Conical Auger	94
6.4.2b	Converging Belt Pre-compactor	96
6.4.2c	Straw Walker Pre-compactor	97
6.4.2d	Roller Compactor	98
7.1.1a	The Botanical Components of the Wheat Plant	107
7.1.2a	Transverse Section of the Wheat Plant	110
7.1.2b	Microscopic Views of the outer surface of Straw	111
7.1.2c	Microscopic Views of the inner surface of Straw	111
7.2.2a	Crushed Straw; Transversed Section at the Fold	115
7.2.3a	Testing Individual Straws	117
7.3.1a	Straw Cross Sections	123
7.3.2a	Straw Orientation in the Die (1)	124
7.3.2b	Straw Orientation in the Die (2)	124
7.4.1a	Mass Distribution of the Botanical Components for Various Species	126
7.4.2a	The Density of Briquettes from the Components	129
7.4.2b	Checking for Adhesive Bonding by Dissection	130
7.4.2c	Illustration of the Loading Curves for the Botanical Components	130
7.4.4a	Relaxation of Samples	135/136

Figure No.	Title	Page No.
7.5.0a	Coil Spring Analogy	138
7.5.0b	Fitted Pressure/Density Relationships for Closed Die Tests	139
7.6.0a	Relaxation Curves for 55mm X 65mm Briquettes (1)	141
7.6.0b	Relaxation Curves for 55mm X 65mm Briquettes (2)	142
8.1.1a	Die Step nomenclature	150
8.2.1a	Die Step Optimisation (results)	153
8.5.1a	Chamfered Die Nomenclature	162
8.5.1c	Equal and Unequal Die Arrangements	164
8.5.3a	Experimental Die Shape (from optimisation)	169
8.6.0a	Draught Angle Investigation; Die Configuration	171
8.6.0b	Draught Angle Investigation; Briquette Shape	172
10.2.1a	Comparison of Theoretical Velocity Profiles	207
10.2.2a	Test Die Shape 'H'	209
10.4.2a	Test Die Shape 'I'	222
10.4.3a	No-Load Inertia of the Rhodes Press	223
10.5.5a	Relaxation of Briquettes formed at High and Low Speed	229
11.0.1a	Reduction in Cross Section in the Pre-compactor	241
11.2.1a	Schematic Drawing of Pre-compactor Rig	245

LIST OF GRAPHS

Graph No.	Title	Page No.
8.1	Specific Energy Experiment	177
8.2	Fitted Load Curve and Regression Output	178
9.1	Graph of Moisture Content against Durability Rating; Type 'G' Stepped Dies	197
9.2	Graph of 'wet' Relaxed Density against Moisture Content; Type 'G' Dies	198
9.3	Graph of 'dry' Relaxed Density against Moisture Content; Type 'G' Dies	198
10.1	Force, Displacement and Energy Comparison for High and Low Speed Loading; Die 'H'	232
10.2	Varying the Charge Mass; Die 'H'	233
10.3	Varying the Charge Mass; Die 'I'	234
10.4	Pre-compaction Test	235
11.1	Pre-compaction Load Curves	250
11.2	Pre-compactor Power Consumption and Regression Output	251

Graphs Appended

I[i]	General Pressure/Density Curve for Closed Dies	266
I[ii]	Loading Curve; Test 12, Chart 1	267
I[iii]	Loading Curve; Test 14, Chart 1	268

## LIST OF TABLES

Table No.	Title	Page No.
2.8.1a	Comparison of the Combustion Properties of Straw with Fossil Fuels	19
3.2.1a	Approximate Bale Dimensions, Work-rates, Power Requirements Capital Costs and Market Shares of various Baler Types	29
3.4.1a	Wheat Straw Buying Prices 1986 - 1989	34
3.4.2a	The Cost of on-farm Baling and Handling	36
3.5.2a	Equilibrium Values for Straw Moisture Content at different Relative Humidities	41
3.5.2b	Comparison of Storage Costs for Straw Products	43
3.5.3a	Procurement Costs	44
3.7.1a	Primary energy Costs of Various Industrial Fuels	49
3.7.2a	Comparison of Installation Costs for Boiler Plant of 1 MW Rating	52
3.7.3a	Example of Comparative Annual Operating Costs for a 1 MW Heating Installation	53
6.3.2a	Closed Rectangular Die Compression Test Results	85
6.3.3b	Shear Test Results	89
7.1.3a	The Chemical Composition of Straw Components	112
8.2.2a	The Energy Used in Shearing	154
8.5.1b	Repeat Results with Equal Dies	163
8.5.3a	Tests Resulting from Mathematical Optimisation (1)	168
8.5.3b	Tests Resulting from Mathematical Optimisation (2)	169
9.2.1a	Durability/Density Results from Stepped Dies	189
9.2.1b	Durability/Density Results from Closed Dies	190
9.2.1c	Durability/Density of Extruded Briquettes	190
9.2.1d	Comparison of Densities for samples held under Load	191

Table No.	Title	Page No.
9.2.2a	Comparison of Bulk and Unit Density	192
9.2.2b	Bulk Density; Theoretical Results to ASAE. 269.3	192
10.5.1a	Varying Speed, Constant Charge; Die 'H' Results	224
10.5.1b	Varying Charge, Constant Speed; Die 'H' Results	224
10.5.2a	Under and Over-charging the Die; Die 'H' Results	226
10.5.2b	Under and Over-charging the Die; Die 'I' Results	226
11.3.2a	Experimental Results from the Precompactor Rig.	248

Tables Appended

Chart 1	Initial Die Shape trial results	264/265
---------	---------------------------------	---------

## LIST OF PHOTOGRAPHS

Plate No.	Title	Page No.
Frontpiece	Prototype Straw Briquetting Machine Undergoing Field Trials, Summer 1988 (Courtesy of British Sugar plc.)	i
4.1	Rolling and Twisting.	65
6.1	Demonstration Models; Conical Disc Compactor.	103
7.1	Transverse Sections of Wheat Straw.	143
7.2	Study of Straws removed from a Briquette.	144
7.3	The Effect of Straw Orientation.	145
7.4	Separated Wheat Straw Components.	146
7.5	Separated Wheat Straw Briquettes.	147
8.1	Compression Test Rig Details.	179
8.2	Samples from tests at various Step Ratios.	180
8.3	Die Arrangement and Result; Configuration 'F'.	181
8.4	Die Arrangement 'G' and Resulting Briquettes.	182
9.1	Durability Test Rig.	199
10.1	Rhodes 100 Ton Mechanical Press.	236
10.2	High Speed Compression Test Rig.	237
10.3	Ancillary Equipment for the H-S Tests.	238
11.1	The Pre-compactor Demonstration Rig	252

Note; Photographs appear at the end of the chapter to which they refer.

## 1. INTRODUCTION

### 1.1 POLITICAL AND ENVIRONMENTAL CONSIDERATIONS WHICH ESTABLISHED THE NEED FOR RESEARCH

Within the last two or three decades, western farming methods have changed almost beyond recognition and, although there have been magnificent increases in food productivity, some of the changes have brought about a great deal of criticism directed towards the farmer from the general public.

As farms have grown larger and more intensive, organised pressure groups have campaigned against the removal of hedges spoiling the landscape and disturbing the intrinsic natural wildlife, the increasing use of artificial fertilisers and pesticides, the noise and nuisance caused by crop spraying aircraft and the use of ever larger agricultural machinery causing hold-ups during road transportation and emitting increasing quantities of hydrocarbon pollutants into the rural atmosphere. The same people have complained about new factory farming methods which give rise to apparently inhumane living conditions for livestock and the degradation of traditional foods into highly cost efficient but pre-packaged, synthetic and tasteless replicas of the original products. In addition to this list of sins are the many problems and irritations caused by the huge quantity of straw being burnt in the fields after harvesting. Of the many subjects where the interests of farmers and environmentalists appear to conflict, this has caused the greatest outcry with complaints about fire hazards, smoke, ash and soot in the atmosphere and the consequent annihilation of wildlife.

It can be seen that agriculturalists are under attack from all sides and the lobby against straw burning, in particular, is growing stronger all the time whereas the amount of redundant straw lying in the fields is still increasing.

Straw; the stems of cereal crops such as wheat or barley, is essentially a waste product of modern arable farming. Before the advent of the combine harvester, straw had to be collected and removed from the field because it still had the ears attached to it. It was threshed during the winter, fed to livestock or used as bedding and eventually returned to the land as manure. Nowadays it is churned out behind the combine harvester onto the field in long swaths and, with the decline of mixed farms and the adoption of more intensive methods, many of the farms which grow cereals have absolutely no use for straw. To make matters worse, there are more hectares of cereals being grown today and the crop yield for each hectare is much heavier. In 1973 there were some 3.6 million tonnes of straw known to be surplus to requirements in the U.K. alone. In 1985 this figure was put at 6.5 million tonnes<sup>(1)</sup> which is between 40% and 50% of the total amount produced as a by-product of growing wheat and barley. According to Hare<sup>(2)</sup> the annual production of straw is likely to go on rising by another 1.3 million tonnes over the next few years until Common Market policies mitigate against further expansion in cereal production. This will very likely be accompanied by an accelerated decline in traditional uses so, by the turn of the century, the U.K. will generate closer to 10 million tonnes of surplus straw every year. In other countries the problem is very much greater; one recent source<sup>(3)</sup> quotes the annual production of cellulosic waste, mainly straw, in the United States as approximately 200 million tons.



The farmer has two main objectives; to maximise crop yield and to clear the field as quickly as possible ready for drilling. To these ends, simply setting fire to the straw where it lays has often been the best way of removing the excess. This method has the advantages of cheapness and speed, clearing the field for early drilling; in addition, it has proved to be an effective weed killer and pest treatment. In this country, local by-laws already limit burning and demand stringent safety and supervision procedures. These are becoming progressively tougher with heavy fines being imposed for non-compliance. The following articles, taken from local newspapers typify the reaction to the annual nuisance and illustrate, admirably, how activity has increased throughout the 1980's to restrict straw burning:

Loughborough Echo, 20th April 1984:

CHARNWOOD Borough Council's health and housing committee gave their approval last week to new regulations covering straw and stubble burning.

The new by-laws, which were passed unanimously, provide for stricter control with increased penalties for non-compliance, following another year of widespread public complaints during the cereals harvest of 1983.

The by-laws ban burning at weekends, Bank Holidays and at night; provide for firebreaks to be constructed against vulnerable objects like houses, trees, hedgerows and crops; and require farmers to incorporate the ash into the soil within 36 hours of burning.

They also restrict burning to no more than 10 hectares in a single block - and for the blocks to be at least 150 metres apart - and require each block to be supervised by two responsible people, armed with adequate fire-fighting equipment.

Loughborough News, 16th August 1989:

Farmers across the county are being urged: "Use straw, don't burn it." The advice comes from David Maclean, Parliamentary Secretary at the Ministry of Agriculture, Fisheries and Food. Cereal farmers are being urged to consider alternative disposal methods.

Mr Maclean said "It will be very difficult to burn straw safely this year given the dry conditions. This is why it is particularly important to encourage those farmers who intend to burn to think again. Those farmers who decide that they must rely on burning should be in no doubt that they have a responsibility to the general public, to road users and to the farming community to exercise the greatest possible care." .....

The National Farmers' Union was generally quicker to respond to public opinion than some of its' individual members and quickly formulated its own burning code which it publicised through A.D.A.S., the Agricultural Development and Advisory Service Department of the Ministry of Agriculture, Fisheries and Food. The original burning code agreed at the beginning of the decade was revised in 1986 with additional controls and tougher policy guidelines.

The prospect of further restrictions on straw burning or even a total ban, such as that already in place in some Scandinavian countries, prompted much activity to find economical alternatives for straw disposal. In many countries campaigns were mounted with indifferent results to try and persuade farmers to use the existing alternatives such as ploughing straw back into the soil or collecting it and using it for fuel. The EEC offered funding for research into methods of straw disposal and the Ministry of Agriculture mounted various campaigns and exhibitions to publicise developments in machinery and

methods. Although all this publicity excited considerable interest in the subject, it was still widely believed that there was not yet a truly viable and economical alternative to burning straw in the field.

In response to a renewed outcry in the particularly mild summer of 1989 the Minister of Agriculture, Fisheries and Food, Mr John Gummer, finally announced to the House of Commons that a total ban on straw and stubble burning would be in place in England and Wales by late 1992<sup>(4)</sup> and that further assistance would be given to researchers seeking to develop new ways of dealing with the surplus straw.

#### 1.2 PROPOSAL FOR A SOLUTION BY MEANS OF TECHNOLOGICAL ADVANCES IN AGRICULTURAL MACHINERY

The purpose of this project, which has been the subject of part-time research since December 1983, was to provide scientific and engineering research data to support the design and development of a particular process and ultimately a machine which would be capable of providing an alternative solution to straw burning. The machine development was undertaken, first by the Howard Rotavator Co. Ltd. of Harleston alongside their normal farm machinery manufacturing business. Unfortunately, this Company was forced into liquidation in 1985 and the unfinished development project together with all rights, patent applications (U.K. Pat Nos. 8320134, 8405786 and 8332827) and the prototype hardware at an early stage of development was bought out by British Sugar plc of Peterborough, who retained the same consultants and continued the project.

The particular solution sought was a machine capable of making dense and durable fuel briquettes directly in the field such that handling, transportation and storage costs could be kept to a minimum. In addition, a financial return could be made on the product which would offset the capital and operating costs of the machine. This new process will be referred to throughout this thesis as the "field-briquetting process".

A thorough search of relevant literature discovered that several organisations have previously tried such an approach but none have yet succeeded, usually because the throughput rate has been too slow or because the energy consumption was too high. Most have attempted to design a machine along the lines of an extrusion press similar to static "farm-yard" installations which are currently available from several European manufacturers.

Static machines, in general, make high quality cylindrical briquettes from chopped straw at rates of up to 350 kg/hour. The relatively high energy input needed to manufacture such briquettes (which totals around 315 MJ/tonne), together with the capital cost of the equipment, the cost of transporting low density baled straw to the site and storing it prior to use, places serious doubts over the viability of this type of plant.

The novel approach taken by the Investigator accepts a general reduction in briquette quality and density in order to restrict the energy input requirement to that which can be supplied by a normal tractor whilst maintaining a throughput rate competitive with small conventional balers; about 10 tonnes per hour. Such a machine would enable high density briquettes to be made on site, in the field.

Transportation and storage costs would tumble because of the reduction in bulk, so the process would become altogether a more economic proposition.

## 2. STRAW IN THE FIELD: A WASTE DISPOSAL PROBLEM OR A USEFUL RESOURCE?

The Introduction established that there is an annual surplus of almost seven million tonnes of unwanted cereal straw lying in the fields of the United Kingdom and that there is an urgent need to find an alternative method of disposal to the environmentally unsatisfactory practice of in-field burning. A large proportion of the surplus is concentrated in the eastern counties of England, notably Cambridgeshire and Suffolk, but a considerable tonnage is also available in central southern and north eastern England.

Throughout the developed world the scale of the waste disposal problem is immense and an excess of straw goes hand in hand with an endemic accumulation of huge stock piles of surplus grain in the west. In this thesis, the arguments will be examined with respect to conditions prevailing in the United Kingdom as, world-wide, there are wide variations in farming practice and scale: it is clear that conditions which apply on a farm in Norfolk would not, in any way, resemble those found in the open plains of Oregon, for example. If the need for the proposed technological solution can be established in the U.K., then it follows that the arguments advanced will apply in even greater measure in the major cereal growing regions of other, larger countries which are even more distant from the major potential points of usage and, therefore, face even larger transport handicaps with the bulky, low density material.

In an attempt to establish the economic feasibility of one particular solution to the problem it will be necessary to make comparisons with the virtues and vices of existing alternative methods of disposal or utilisation.

## 2.1 INCORPORATION - (Ploughing in)

Incorporation produces some adverse effects, notably poor seed beds, blocked drill coulters and reduced yields. Considerable work has been done to alleviate these problems. The Agricultural and Food Research Council (A.F.R.C.) at Silsoe, in particular, has done much investigative work in this area. From single-year experiments they concluded that even finely chopped straw buried deeply (10-15 cm) may result in yield losses up to 9 per cent compared with those obtained immediately after burning<sup>(5)</sup>. One long-term trial, with shallow incorporation on a heavy soil, revealed losses up to 28 per cent and tended to increase in each succeeding year. The extended experiments of J. P. Graham<sup>(6)</sup> showed that the highest yields were obtained when the straw from the preceding crop had been burnt and that the lowest yields were obtained by chopping the straw and spreading it on the surface prior to drilling: reductions in yields from this experiment ranged from 13 per cent to 29 per cent. When straw was chopped and thoroughly incorporated into the soil the yield losses ranged up to 11 per cent.

Further work is being done, at research establishments, to improve the available machinery for chopping and burying straw and detailed studies are in progress to see how widespread these yield losses are likely to be with regional variations in soil and weather conditions, the amount of straw to be incorporated and the method of incorporation. Although the most recent trials conducted by the Agricultural Development Advisory Service (A.D.A.S.) have given more encouraging results under certain conditions<sup>(7)</sup> no one system has yet emerged which is competitive with burning in terms of operating costs, speed of clearing the field and quality of the soil for the succeeding crops.

In practice it is virtually impossible to incorporate unchopped straw using conventional cultivation equipment, even if it is evenly spread behind the combine harvester. Straw must also be chopped before spreading to aid distribution in the soil. The chopping operation can consume 25-30 kW of power<sup>(8)</sup>. This is probably best achieved with an attachment mounted on the output of the combine as the additional power requirement is likely to be already available. Fuel consumption will, however, be increased by around 15 per cent<sup>(9)</sup>. About one third of all new combines sold are now fitted with choppers for this purpose<sup>(10)</sup>. The alternatives to a combine mounted chopper are a tractor drawn machine: a specialised straw chopping implement would use more power than a combine mounted chopper and may not pick up all the swath, leaving some straw untouched. It would require an extra field operation and the cost would be typically four times that of using a combine mounted device<sup>(9)</sup>: some soils and/or incorporation methods may require a particularly fine chop length. In this case a forage harvester can be used but, although the farmer may already own such a machine, the process is both time consuming and expensive.

The problem of yield reduction after incorporation can be alleviated, to some extent, by the addition of extra fertilisers and conditioners to the soil. More weed and insect controlling additives are also required when burning has not taken place. The A.F.R.C. suggest an additional cost of about £12 - 14 per hectare for sprays etc.<sup>(5)</sup> Weed control would be required, however, even when straw is removed for other purposes unless the stubble left behind by the combine can be incinerated.

A considerable number of machinery manufacturers now offer equipment for straw incorporation and go to great lengths to expound the virtues



of their systems. Understandably perhaps, because despite the obvious drawbacks, "ploughing in" is, as yet, the only practical large scale alternative to burning for most farms in Eastern England.

## 2.2 BUILDING MATERIALS

Straw can be combined with a number of resins to produce particle board, which has a potential market in the construction industry. A process, developed and patented by a Danish industrial firm in co-operation with the Biotechnical Institute of Denmark, involves grinding the straw and etching the outer wax layer before bonding with a modified urea-formaldehyde. The board can be given a wide variety of surface finishes and has several applications in the interiors of buildings.

In addition a relatively small quantity of straw is used each year in the manufacture of insulating materials. The product can be used for insulating roofs, walls and for sound-proofing.

These industries face prohibitive transport, handling and storage costs due to the great bulk of the raw material and its seasonal availability, so they have been confined to small scale operations in locations where straw is abundant. There are more than twenty such plants in operation throughout the world but the industry has, so far, found few friends in this Country.

## 2.3 PAPER MAKING

Straws of various types have been used as a source of paper-making

fibres over many centuries, and historically they were the first source of such fibres. However, since World War II straw has not been used for this purpose in this Country or the United States because there have been generally adequate supplies of wood pulp. Wood pulp lends itself to a better quality product, more convenient processing methods and incurs significantly lower transportation costs.

This situation may be about to change as conservationists fear for the rapid destruction of forests. British Sugar plc has recently declared its interest in the possibility of using straw for paper products and has estimated that a new paper-making plant, based at the heart of Britain's arable farming centre, to minimise operating costs, would require a capital investment of between £60 and £80 million. However, although the feasibility of such an operation has been extensively studied, no firm plans have yet been announced.

Other sources are less optimistic that a new paper making industry could be viable and solve the farmer's problems. In a review published in late 1984<sup>(11)</sup> the capital costs of a straw pulping mill with a 200 000 tonnes annual output were quoted as equivalent to £440 per tonne and this compared with £400 per tonne then being paid by British newsprint buyers for imported bleached softwood pulp. Even if the comparative economics should change, the estimate for the total U.K. consumption of straw, supposing it became the predominant raw material in the paper making industry, is 1.2 million tonnes per annum, only 20 per cent of the surplus.

In October 1987 and again in May 1990 international conferences organised by the Paper Industry Research Association on the subject of

straw utilisation clearly indicated that research into straw usage for paper making is, however, very much alive.

#### 2.4 ANIMAL FEED

The digestibilities of all the constituents of straw are low and the lack of palatability and density further reduce its effectiveness as a livestock feed. Research on use of low quality roughage has already been carried out at several institutions and has invariably involved: improvement of the nutritive balance by the inclusion of various additives; altering the physical characteristics into a more palatable form by grinding, cubing or pelleting; chemical degradation of the less digestible parts of the straw using caustic soda or a similar strong alkali. It can be seen that although it is quite feasible to manufacture a nutritious and palatable winter cattle feed by these methods, the process is not simple and other raw material additives are required in large quantities. The process is, therefore, expensive when compared with other low-cost feed sources which are plentiful such as cannery waste and cull potatoes. It is quite ironic, also, that the mountains of rotting human foodstuffs, which were created by over-efficient western agriculture during the last decade, are now disposed of for animal nutrition.

The most recent advances in the usage of straw for fodder have involved the injection of aqueous ammonia into large round bales in stacks or ovens. This results in a 5 - 10 per cent increase in digestibility and an improvement in the protein content<sup>(8)</sup>. The main advantage of this system over the more complicated feed pellet processes is that it can be done in situ on the farm.

Trials conducted over a ten year period at the National Institute for Research in Dairying<sup>(11)</sup> have shown that diets containing up to 60 per cent straw and a protein supplement can meet the necessary growth requirements of dairy heifers and, with efficient processing and supplementation, successfully reduce the dependence on bought in feeds. The major problem associated with research in this area has been caused by the general move away from mixed farming on the grounds of efficiency. Straw is abundant in areas where arable farming is dominant, yet scarce in areas which concentrate on dairy farming so, again, transport and storage costs of a bulky commodity are prohibitive for widespread, and large scale expansion of the use of simply treated straw bales for animal feed.

## 2.5 HORTICULTURAL USES

Straw is used as the substratum for composts in the mushroom industry. Bales have been used to replace soil or compost modules for growing glasshouse crops. Small quantities of straw are used in the production of field crops, notably for the traditional strawing of strawberries and for frost protection of overwintered carrots and stored vegetables.

Straw has even been converted into a nitrogen rich compost by means of a process developed by the Agricultural and Food Research Council. The patented process depends upon a fungus, a member of the penicillium group, breaking down the cellulose and related materials in the straw and the addition of a bacterium which lives on the product of this degradation. Although the process seems feasible in the laboratory it has yet to prove its worth on a large scale.

## 2.6 PETRO-PRODUCTS

It is technically feasible to use straw as a raw material in the manufacture of oil, petrol, alcohol and plastics. Unfortunately bulk reduction, lengthy degradation cycles, transportation costs and seasonal availability have prevented straw from being competitive with alternative raw materials. A research project at U.M.I.S.T.<sup>(12)</sup> has demonstrated that the oil which can be produced from straw has a high calorific value and is ecologically attractive in its chemical constituents, however the process, is still some way from commercial realisation.

## 2.7 THATCHING

No more than 15000 tonnes of specially grown wheat "reed" are used for thatch each year but, at around £350 per tonne it makes a valuable contribution to the income of smaller farms, mainly in the west country. Any major expansion of this specialist market seems, however, unlikely.

## 2.8 STRAW FOR FUEL

The idea of burning straw in fireplaces or specially constructed furnaces instead of in the field appears to be basically a sound one. In terms of energy wasted the figures are impressive.

Using the most recent Ministry of Agriculture, Fisheries and Food Figures (1984) there are at least 6 million tonnes of straw burnt or

incorporated each year in the U.K. Also, straw has an approximate calorific value of 15 GJ/tonne, so the potential heat energy available per annum is;

$$6 \times 10^6 \times 15 \times 10^9 = 9 \times 10^{16} \text{ Joules}$$

This is equivalent to a continuous power source of over 2800 MW spread throughout the year and represents approximately one quarter of all the energy used in the agricultural, horticultural and supporting industries throughout the U.K. or about twice the requirement to heat and provide hot water for the 250,000 farm houses and cottages that exist throughout the country<sup>(13)</sup>.

It has been shown that there are several ways in which straw can be used to replace fossil fuels for heating. Specialised bale burners have been installed in farm houses, glass houses, grain driers, piggeries and even in one southern stately home. A 20 kg. bale of dry straw contains roughly the same energy as 10 kg. of good quality coal or 6 litres of oil. Many designs of straw fired heaters are available, producing either hot water or hot air. The trend has been towards bigger and more sophisticated burners to improve overall efficiency. There are now several installations in operation with outputs greater than 1 GJ and the largest U.K. straw burner is rated at over 20 GJ. On large scale installations, where throughput is heavy and automatic handling is required, it is usual for the straw to be broken down and chopped before being fed to the furnace. The main problems with this system is that great quantities of loose ash within the furnace reduce combustion efficiency and, of course, the additional chopping process is expensive.

The heat loads encountered in heating horticultural and livestock buildings normally dictate the use of expensive mechanical handling systems. Direct automatic stoking of big bales has been tried but the traditional package sizes have proved inconvenient for automatic handling. In addition, tests have shown reduced heat outputs and severe control difficulties with big bale burners. The relatively low density fuel dictates that very large furnaces are required and these have poor burning characteristics. The loose straw on the outer edges of the bales burns quickly, surrounding the centre of the bale with ash, which tends to cause the bale to smoulder rather than burn efficiently. The bales also give uneven heating of the furnace due to the concentrations of fuel in certain areas.

To overcome these problems it is necessary to:

- (i) increase the density of the straw beyond that of a bale;
- (ii) decrease the size of each unit of fuel to overcome handling and combustion problems;

i.e. - form wafers or briquettes.

Furnaces fed with high density straw briquettes or wafers have generally proved to have superior combustion characteristics and also lend themselves to automation as the bulk of the material is much reduced. A number of commercial briquette making installations are now in use. All employ the extrusion principle and produce convenient fuel suitable for large scale furnaces or even domestic stoves and open fires. Although this process would appear to solve many of the problems associated with burning straw, it is the economic feasibility

of replacing fossil fuels in this way which requires close scrutiny. Comparisons with other fuels must cover fuel cost at the point of burning, the cost of plant and heater installation, combustion efficiency and labour requirements.

Table 2.8.1a shows a comparison of the calorific value, the bulk density and the combustion efficiency of straw products with the major fossil fuels. The figures given in the table are based on the aggregate of values taken from informed reference sources<sup>(9,13,14)</sup>.

Despite the obvious difficulties many people, farmers in particular, have realised the attractions of straw as a fuel. In 1985, 160,000 tonnes were used<sup>(10)</sup>, mostly for farmhouse and animal house heating and the usage is increasing steadily each year. All sources indicate, however, that it is the low-density/high-cost transport and storage requirements of baled straw which are the main reasons why the use of straw as a fuel is yet to become widespread among major industrial energy consumers away from the farms, themselves.

Existing briquette technology does little to answer this problem as baled straw has to be taken to and held in stock at the static plants where running costs are high and output is low. This type of operation more readily lends itself to producing a high quality product in relatively small quantities for sale as domestic fuel. Indeed, the low economic return led to a slow take-up of this process and several leading machine manufacturers are now known to have withdrawn from the market.



	Calorific Value MJ/kg	Unit Density kg/m <sup>3</sup>	Bulk Density kg/m <sup>3</sup>	Combustion Efficiency %	Ash Content % by wgt
Straw, 15% moisture content:					
Conventional bales	15	110	100	(*64)	7.5
Round bales	15	100	65	(*64)	7.5
Hesston 4800 bales	15	150	140	(*64)	7.5
Extruded briquettes	15	1100	450	(*71)	7.5
Field briquettes (objective)	15	600	350	(*71)	7.5
Medium fuel oil	42.9	900	900	75	0.04
Bituminous coal	28	1350	790	71	5
Seasoned timber	16	1175	700	60	1.25

\* Combustion efficiencies quoted for straw burning appliances vary greatly according to the type and size of the operation. Well below 60% will be achieved in small scale hand stoked plants burning whole bales, however 75-80% is realistic on large scale, appropriately designed, equipment burning conveniently sized briquettes. With this in mind it is reasonable to assume that a similar overall efficiency to that of coal fired appliances could be achieved using appropriate technology for straw briquettes and that this efficiency will be, perhaps, 10% better than that achieved using baled straw to best advantage.

Table 2.8.1a Comparison of the Combustion Properties of Straw with Fossil Fuels.

### 3. THE ECONOMIC ARGUMENT FOR PRODUCING BRIQUETTES IN THE FIELD

#### 3.1 PROCESS SYNTHESIS

The transformation of crop materials from their raw state, as they lie in the field, into usable fuel in the feed hopper of an industrial heating plant is a complex mechanical handling problem. There are, of course, a great many alternative scenarios which could be proposed but the objective of this research is to examine in detail only the possibilities for processing straw in the form of briquettes.

##### 3.1.1 Static briquette-making plants

Figure 3.1.1a illustrates the process flow associated with a contemporary static briquetting plant. It illustrates both in-house usage and external sales and demonstrates why additional stock holding capacity would be required. Usage is unlikely to be matched exactly to production, especially if the briquette machine is down. Various permutations and modifications on this processing system could be suggested to improve efficiency. A semi-mobile or portable briquetting plant could be transported to and from the operating site where it could be more readily supplied with raw material. The improved process flow for this type of system can be seen in figure 3.1.1b. Both these systems, however, suffer the same major inefficiencies associated with double handling and unmatched performance characteristics.

##### 3.1.2 Fully mobile briquetting machines

A very different process flow system would appear if the briquette-

making plant could be made fully mobile, capable of operating directly in the field.

It would require a machine to lift the straw directly (i.e. the combine swath), compact it, and discharge briquettes in continuous or bagged form. Naturally then the briquette machine would need to traverse the field, be capable of following the swath at field edge and in the corners and cope with likely gradients. Remembering that a combine harvester must precede such a machine would give a good indication of the stability and manoeuvrability needed.

Again, there would be more than one option to consider:

- i. A self powered briquetting vehicle.
- ii. A towed machine using a tractor Power Take Off.

In theory, a towed self-powered machine is possible but this would be a somewhat pointless option and requires no discussion.

Figure 3.1.2a shows the process flow for the mobile briquetting concept. From the diagram it is clear that the whole procedure has been greatly simplified by direct briquette production. Bag handling would need further work, if required, but no more than would be necessary for the other concepts.

A decision between self-powered or tractor-towed machinery would be influenced by technical as well as economic factors as the power limitations would be clearly more acute if a conventional tractor were to be the source. The following discussion assumes that both solutions are technically feasible.

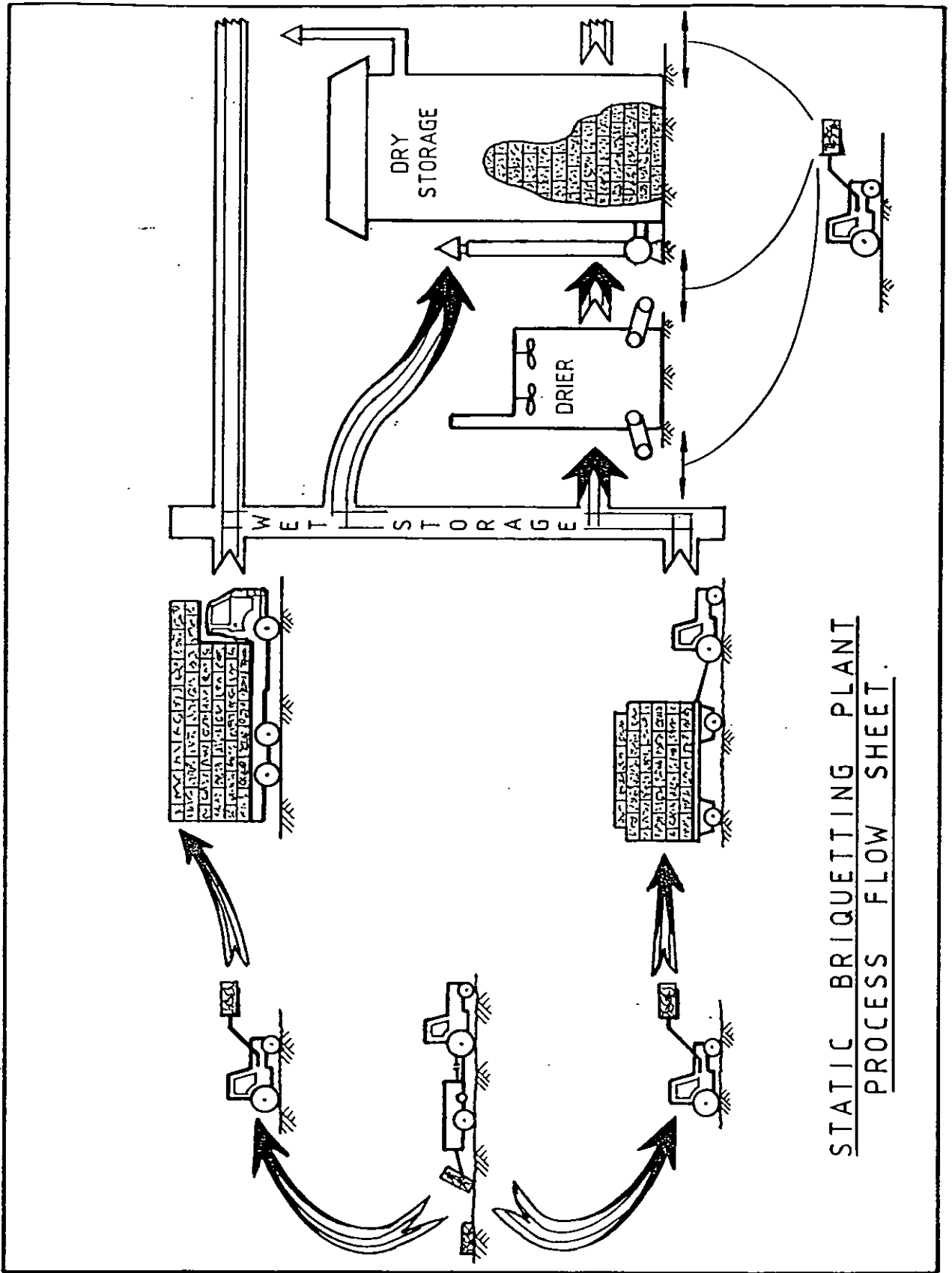

STATIC BRIQUETTING PLANT  
PROCESS FLOW SHEET.

Figure 3.1.1a

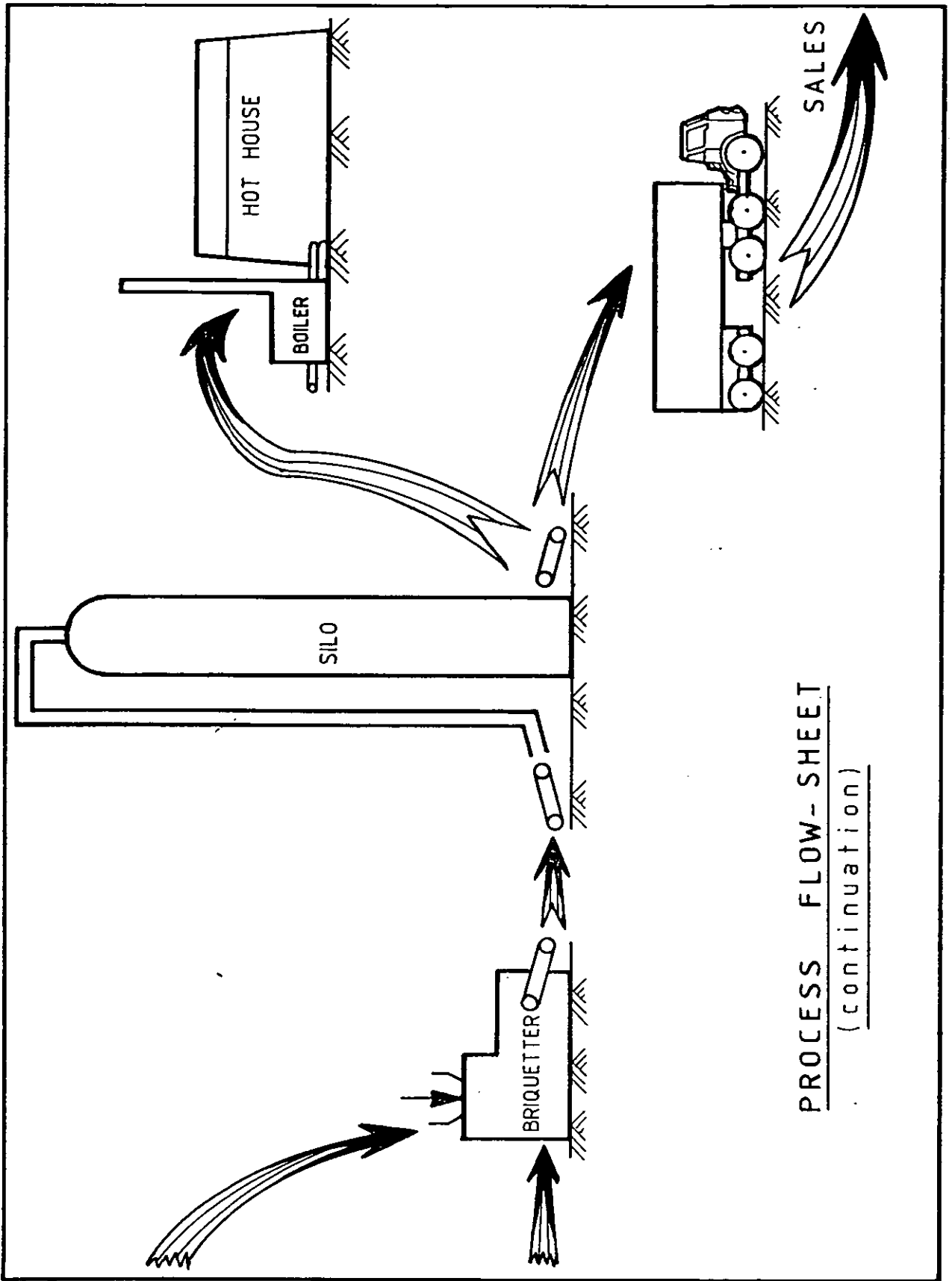

PROCESS FLOW-SHEET  
 (continuation)

Figure 3.1.1a (Continuation)

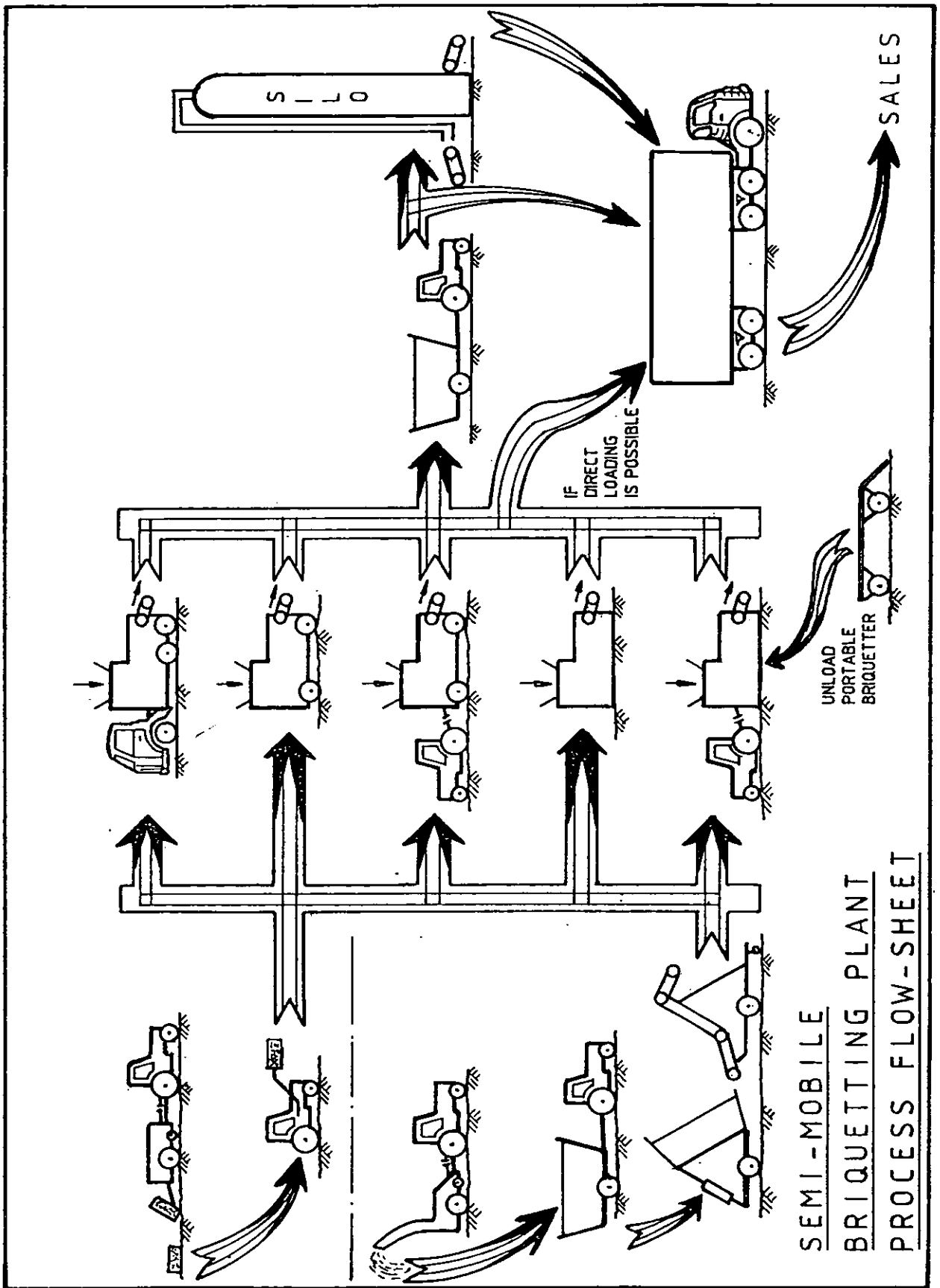

Figure 3.1.1b

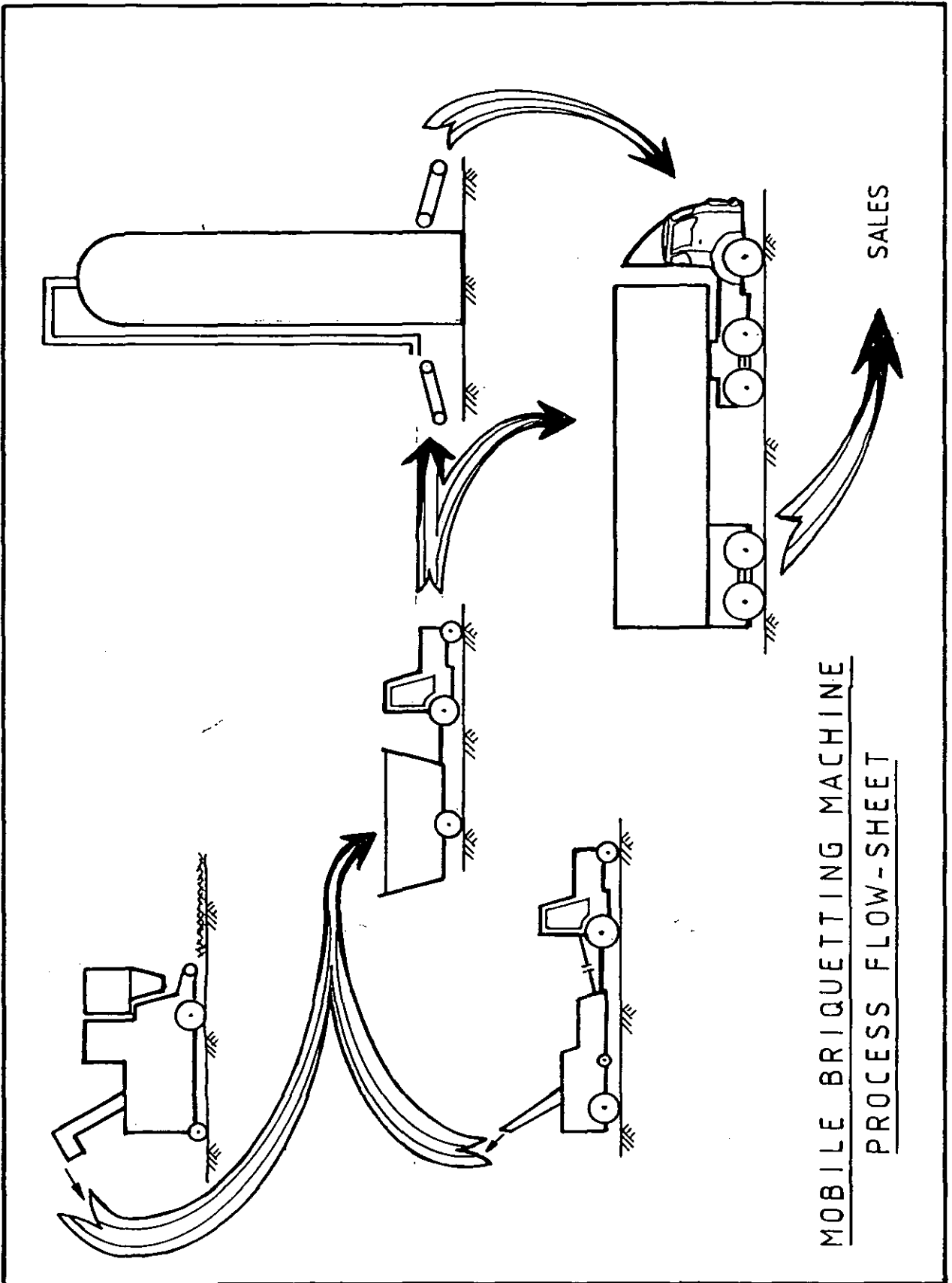

Figure 3.1.2a

## Self Powered Briquetting Machine

This hypothesis entails a major piece of agricultural machinery similar in many respects to a combine harvester - power consumption (order of magnitude) complexity, and ultimately, capital value. The majority of small farms do not invest in such a way, saving only to hire when appropriate from a contract fleet although user ownership is becoming more widespread. As with the semi-mobile plant scenario, it is not difficult to see how this type of machine could be adapted for processing straw which was held in stock out of season to increase the machine's usefulness. At the time of harvest, however, the machine would have to be rated to cope with each farm very rapidly and, quite likely, several of these machines would operate in any given region. It should be noted this would represent a significant initial capital outlay for the plant operator and this would inevitably be reflected in the hire charges and plant operators would need the confidence that the farming region was committed to the endeavour before making such a large investment. Hiring combine harvesters is comparatively risk free since the need is already guaranteed, but the successful introduction of briquetting machines would rely on a large scale change of attitude. Farmers would only consider change if a profit was assured which, in part, would infer low hire rates. The contractor would, therefore, need to be very careful to ensure his business was sound yet his charges were competitive. He would have to cover all servicing and maintenance costs plus the depreciation on his investment together with his running costs (fuel and tyres), delivery and storage; however, if his contract charges were excessive, it would be fair to assume that the farmers would not hire and revert to large scale burning. Problems very similar to these were, of course faced at the time when combine harvesters were introduced. Resistance to



change was largely overcome, however as the benefits of the high capital machinery became obvious.

It would be very difficult to quantify the attitudes of the farming profession as a whole. On the one hand there is the modern, high technology farm eager to exploit yet a further resource, whereas for many more conventional farmers it would take more than just a profit motive to induce major change. Legislation, which restricted straw burning, perhaps would be the only sufficient motive for rapid conversion.

#### Towed Briquetting Machine

A tractor trailed field implement would still be a complicated piece of agricultural machinery, but one that might be within the range of the farmer to own himself. This scenario, therefore, completely eradicates all the problems of distance from the base plant, a controlling contractor and a simultaneous change of attitude. This way the farmer could decide for himself and invest over a period of years in the relevant hardware. Initially perhaps on a small scale, with the basic machine allied to his existing tractor to replace the baling operation, possibly using the product for domestic consumption. Addition of a bagging plant would be sufficient to give him a marketable product. The bagging equipment might have additional supplementary uses with other crops.

Further developments could include a silo for bulk handling and, perhaps extensive modifications to the farm's commercial and domestic heating or grain drying boiler systems. Under these conditions, the farmer would not be reliant on a contractor or tied to his terms and

conditions and could proceed at his own pace. The most appropriate scale for individual operations would largely be dictated by prevailing local conditions, (see section 3.3 - Market Possibilities). Here again, legislation or a grant may be required to prompt widespread acceptance of the operation. At this stage, therefore, the smaller capital cost and the greater flexibility of a tractor towed implement is likely to be preferred.

### 3.2 A NEW DIMENSION

Early laboratory work (see Chapter 6) indicated that briquette packages, made with a tractor-towed field implement, with a power availability limited to around 100 kW, would have a unit density of around 500 - 600 kg/m<sup>3</sup> and would be most conveniently sized at around 50 mm cube. It was quickly realised that, for such a machine to have a chance in the market place, it would need to satisfy the farmers demand to clear the field quickly and allow him to cultivate the land for the next crop. The machine would, therefore, have to operate in the field at speeds competitive with conventional balers and this indicated that around ten tonnes of straw per hour would have to be processed. Simple mathematics reveals that, under these conditions, the machine would need to produce almost 40 briquettes every second reliably and continuously throughout the short harvest periods.

Baler Type	Bale Dimensions (m)	Typical Bale Weight (kg)	Output (t/hr.)	P.T.O. Power Required (kW)	Price Guide (£)	U.K. Market Volume (units) (p.a.)
Conventional rectangular	0.36 x 0.46 x 0.5-1.2*	18	5	35-45	6300	1500
Large round	0.9-1.5 dia.* x 1.2	185	7	38-50	10000	2000
Large rectangular (Hesston) (4800)	0.8 x 0.8 x 1.6* (1.2 x 1.2) ( x 2.5 )	160 (540)	Up to 15	65 plus	42000	50

Source: baler manufacturers (various)

\* adjustable

Table 3.2.1a Approximate Bale Dimensions, Work Rates, Power Requirements, Capital Cost and Market Shares of Various Types of Baler

### 3.3 MARKET POSSIBILITIES

From the outset, it was felt that the main market for the type of briquettes under consideration was unlikely to be as a domestic solid fuel for open fires and small central heating boilers. Owing to the greatly reduced power input envisaged, the product would inevitably be of a lower quality than briquettes produced by static extrusion plants which are currently sold for domestic purposes under the trade name

"Supaglo". These extruded briquettes are packed in 20 kg polythene bags and sold in farm shops and filling stations. "Field" briquettes would be of a quality more appropriate for bulk handling and consumption, either on the farm where they were produced, as fuel for heating plants and grain drying installations or for large scale consumption by horticulture (glasshouse heating) and industry. These installations would be expected to take advantage of the relatively low value of straw in the field, the ease of mechanical handling of conveniently sized units together with the reductions in haulage and storage costs given by the greatly reduced bulk compared with baled straw. Likely users would still, however, be restricted to installations conveniently situated in the major arable farming areas where overheads could be minimised and continuous supplies would be assured. Large industrial consumers would be likely to enter into long-term supply agreements with several cereal farmers within their locality and transport contracts involving hauliers who operate heavy tipper lorries. On a larger scale still, an even more organised structure could be envisaged, perhaps operating on similar lines as the Milk Marketing Board operates for dairy produce. This type of structure for controlling supply and demand could oversee the purchasing and marketing of the fuel and advise producers and users alike on the equipment required and the likely benefits.

If the introduction of a new handling technology enabled straw to compete as an industrial fuel then, logically there would be a much greater demand from farmers, so the question arises: would they be prepared to meet this demand at competitive prices or would they prefer to continue with their well established methods of straw disposal, like field burning or incorporation? Clearly, any major escalation in the market price of straw products would be self

defeating and would quickly erode any competitive edge that could be gained by the new briquette-making process.

Whether or not the farmer could be persuaded to adopt a new technology would depend, mainly, on two influences:

- i. Environmental (and legislative) pressure
- ii. Economic advantage

Although the main market for briquettes is likely to be for fuel there is no reason to suppose that, if a field compactor became available, a secondary market could not be set up to distribute briquettes for most of the other uses already identified in Chapter 2. The raw material would still have the same value as a cattle feed base on dairy farms, for instance, even when it had been formed into briquettes. The reduced transport and storage costs of briquettes could possibly provoke an expansion in the use of treated straw for fodder. It should be noted that this type of briquette can be easily reconstituted as it will swell rapidly and disintegrate completely into a tangled mass within a few minutes if it is immersed in water<sup>(15)</sup>.

It was concluded, therefore, that there is more than one market open for straw briquettes of the type perceived and that success or failure in the market place will depend mainly upon the price of the product at the points of usage, in comparison with the prevailing price of alternative fuels.

It is perhaps worthy of note that, although this thesis is primarily concerned with the evolution of a new machine for processing straw,

the technology which is derived may well be applicable to other field crops such as hay or lucerne which have a higher market value as cattle feed. This aspect, although not fully investigated in this project, must serve only to increase the value of the technology by widening the potential market.

### 3.4 THE COST OF STRAW ON THE FARM

The price of straw at the farm gate and the profit margin expected by the farmer will be heavily influenced by the quantity in which it is sold. The foregoing sections assumed a global supply contract between the farmer and the end user to purchase and remove all the excess straw production in the light of increasingly restrictive burning laws. In this case the profit margin enjoyed by the farmer is likely to be minimal as he would welcome a speedy and reliable alternative to burning where all his handling costs could be recovered with the bonus of a small regular income.

The predominant factors affecting the cost of straw at the farm gate are therefore:

- i. Its value to the farmer
- ii. The cost of handling.

#### 3.4.1 The value of straw to the farmer

Straw in the field only has a value in quantities which can either be used by the farmer himself, or if there is a ready outlet for selling it as a commodity. It has already been shown that large arable farmers have little use for straw as animal bedding or feed and that

existing markets for straw are limited. It would, therefore, be logical to assume that the excess straw in the field has, at present, no value. In a conversation with one local arable farmer, it was revealed that he was happy to give his straw away to a neighbouring dairy farmer in return for assistance with collection and baling. If, however, a new demand for straw fuel, in quantity, was created, then the surplus straw at farms within range of the user would gain an intrinsic value and the farmer would inevitably wish to reap a part of the reward. Similarly, if the new usage became so significant that the supply of straw to existing users was threatened, then market forces would inevitably cause the price to rise still further.

Assigning a specific value to straw lying in the field in these circumstances is not easy and to a great extent is dependent on the circumstances of a particular farm. Values quoted for this in farming journals range from £0 to £15 per tonne but the consequence of implementation of the N.F.U. Straw Burning code and of tougher by-laws is that more straw is presently available at lower prices, so a value towards the lower end of this range is suggested, perhaps £3.

Table 3.4.1a lists the merchants prices paid for baled wheat straw, ex-farm for the years 1986-1989. Seasonal changes are apparent which illustrate how, if the straw is stored for sale to a merchant, its price will increase through the year. The actual size of the increase, is however, more likely to reflect the reduced availability of the commodity rather than the actual cost of storage to the farmer. It also shows quite a striking and consistent variation between the two chosen regions and in both cases a peak of demand during the winter months when livestock are kept indoors.

With a ban on field burning almost certain to come into force in the near future, the surplus of straw will become acute in arable regions. The effect of this will be to further depress market prices.

---

£/tonne	1986		1987		1988		1989	
	East Anglia	East Mids.	East Anglia	East Mids.	East Anglia	East Mids.	East Anglia	East Mids
Jan.	20	15	18	16	25	20	20	18
Feb.	20	14	18	16	25	25	20	18
March	19	14	18	16	25	25	20	18
April	19	14	18	16	25	25	20	18
May	17	14	20	16	25	20	21	18
June	17	14	20	16	25	20	19	20
July	17	14	20	16	25	20	-	-
Aug.	17	-	12	-	-	-	14	-
Sept.	12	-	12	-	13	12	15	14
Oct.	13	12	18	12	14	14	17	14
Nov.	17	18	18	18	19	15	18	14
Dec.	18	16	22	20	20	18	20	14

---

Source: Data Compiled from Prices Published in Farmers Weekly

Table 3.4.1a Wheat Straw Buying Prices 1986-1989

On the face of it, the prices quoted in the table seem rather high which suggests that they reflect the cost of producing straw rather than its material value; as the price so obviously depends heavily upon the laws of supply and demand and the commodity is generally in surplus, it does not necessarily follow that these prices are profitable for the farmer. Indeed, agriculturalists are actively demonstrating their reluctance to trade straw at these prices by burning large quantities in the field and major changes would be required before the farmer looked upon straw as a valuable cash crop.



### 3.4.2 The cost of baling and handling

As a result of the relatively low margin which can be expected from producing straw and the economies of scale to be found with more sophisticated equipment, the cost of handling straw will depend heavily upon the total amount collected and the bulk of the packages to be handled. The greater the amount of straw removed and the higher weight-to-volume ratio of each package, the lower will be the unit cost for the end user.

The figures in Table 3.4.2a were produced by Silsoe College (1985) to investigate the economics of high cost balers producing large rectangular bales compared with the more conventional systems. In both cases they show a marked reduction in unit cost as the quantity handled increases but they also illustrate that the higher capital cost of the straw handling equipment, more suitable for handling larger quantities, has an equally marked effect. The farmer may, however, be pleased to accept this penalty, particularly on large farms in return for increased speed of clearing the fields because a single conventional baler could not be expected to handle much more than 1000 tonnes during one season.

Smaller farmers may consider contract hire of the equipment for short periods would be more prudent. In the early days of combine harvesters, the high investment was certainly made, in the main by agricultural and plant hire contractors and the costs were spread in this way. Contractors currently charge between £10 and £12 per tonne for baling only, for all types of bales.

---

CONVENTIONAL & ROLL BALER SYSTEMS

Tonnes baled per season	250	500	1000
Cost per tonne (£)	16.60	11.40	9.35

---

HESSTON 4800 BALER

Tonnes baled per season	1000	2000	3000
Cost per tonne (£)	18.75	13.60	12.71

---

Table 3.4.2a The cost of on-farm straw baling and handling  
(includes capital investment costs)

### 3.4.3 The cost of field-briquetting and handling

The cost of using the field-briquetting system conceived in Section 3.2 would be governed by the same rules as baling;

- Package size for ease of handling
- Total quantity handled per season
- Capital investment cost of the machinery
- Manpower requirements.

The main advantage of straw in briquette form has to be the ease with which the product can be handled and the relative efficiency of such a system. The briquettes could be fed immediately into a lorry travelling alongside the machine, for instance, cutting out the secondary lifting operation to remove the bales from the field and, in the case of large bales, making the heavy lifting equipment redundant and keeping manpower requirements to a minimum.

The total quantity of the straw processed in the season, when maximum usage is assumed, is primarily dependent upon the hourly throughput of the machine. As already stated, the aim is to produce a competitive machine and for this to be achieved a throughput somewhere between that of the conventional baler and the Hesston baler systems will be required (up to 10 tonnes per hour).

Although no actual work-rates or capital costs are yet available for such a system, it would be reasonable to assume that the advantage in handling the more convenient briquette packages would approximately equate to the disadvantage of a slightly lower tonnage processed when using a large bale system. If the capital costs of a briquetting machine were roughly the same as a Hesston 4800 baler, then the overall cost of handling straw in field briquette form must be of the same order.

Field briquetting process, summary (1988 Prices)

Value of straw in the field: £3 per tonne

Cost of briquetting and handling on the farm:

Approx. £19 per tonne at 1000 tonnes per season

or £13 per tonne at 2000 tonnes per season

Target cost of briquetting machine: no more than £42000.

### 3.5 THE COST OF PROCURING STRAW FOR INDUSTRIAL OR HORTICULTURAL FUEL

The model under investigation assumes that straw is purchased, in quantity, from several farms within, perhaps a 30 mile radius of the end user. The price paid at the farm gate must be adequate for the farmer to recover his costs and maintain a small profit. The figures quoted in the preceding sections suggest that for straw products like Hesston bales or field formed briquettes, the likely farm gate price must be in the region £16 - £22 per tonne in order to maintain incentives; only legislation banning straw burning would force the farmer's hand and effectively reduce this figure. A nominal price of £18 per tonne will be taken as a realistic minimum under existing conditions. To this must be added the cost of transport to and storage at the boiler installation.

#### 3.5.1 Transport

For road transport over any considerable distance it is difficult, if not impossible, to carry a full payload of straw bales. Assuming the maximum height and width of a load to be 3 metres and 2.5 metres respectively, then a 12 metre float bed trailer with a maximum payload of 24 tonnes would have a volume of 90 cubic metres. Hence a minimum bulk density of  $270 \text{ kg/m}^3$  would be required for the vehicle to operate at optimum efficiency. This is the largest type of vehicle in use for agricultural purposes and because it is so large and cumbersome it is best suited to short journeys and good road conditions. Clearly, in terms of payload, even when the most efficient large rectangular bale system is used, giving a bulk density of around  $140 \text{ kg/m}^3$ , the vehicle must run at half capacity. This situation is made even worse because the dimensions of the Hesston bale are such that a stack of three

layers (3 x 1.2 metres) will not meet current road haulage regulations; indeed bridges will not be cleared, but a stack of only two layers is inefficiently low. The more common Round bales stack even less efficiently and can easily halve the payload again, whereas the use of a more manageable 7.4 metre length trailer would have the effect of limiting the payload to about 5 tonnes of conventional bales.

The type of transport required to move straw briquettes in bulk would be rather different. Instead of flat backed low loaders onto which bales can be lifted either by hand in the case of conventional bales or by fork-lift for large bale systems, fully enclosed tipping lorries would be required.

Conversations with local hauliers revealed that, although there is no formal standard for the physical size of these wagons, the most commonly found large tipper has a cubic capacity of around 55 cubic metres and a payload of 24 tonnes. This type of vehicle is widely used for hauling other loose agricultural products such as sugar beet, potatoes or turnips and has a body length of around 7.5 metres with the advantage in driveability over long flat-backs. To achieve maximum economy with this type of vehicle, a bulk density of some 430 kg/m<sup>3</sup> would be required but even straw briquettes, with a relatively low bulk density of around 250 kg/m<sup>3</sup>, would enable 19 tonnes of fuel to be carried in a single load; almost four times the weight of conventional straw bales on a similar length low loader and more than 1.5 times the weight of the less common Hesston bales which could be carried short distances on a 12 metre trailer. Employing tipper trucks would also reveal a marked advantage in time and effort for unloading, being a simple, one-man automatic operation.

The actual cost of haulage would depend on many factors such as the size of lorry used, the amount transported, the speed of loading and unloading and the distance travelled. It would not, of course, be a constant for every installation. Figures quoted in Power Farming Magazine<sup>(11)</sup> suggest that the actual cost of moving straw bales 100 miles ranges from £9 to £20 per tonne depending on the bale type and the vehicle capacity. Accepting the reduction in cost for carrying field briquettes to be 1:4 compared with the poorest conventional systems, or 1:1.5 against the current optimum, suggests that an overall cost of transporting briquettes should be no more than £5 or £6 per tonne compared with an average £15 per tonne for existing bale systems. Limiting the distance from which straw is collected to within, say, 30 miles radius could further reduce these figures, in proportion, to around £3.50 per tonne for briquettes or £10 per tonne for bales.

### 3.5.2 Storage

The cost of storing straw or straw products is a little easier to assess as there are fewer variables involved in the analysis. If straw, in whatever package configuration, is to be used for fuel, it is vital that it should be kept in a dry condition. A single 19 tonne lorry load of straw with a moisture content of 10% will provide some 4500 kW-hr. more energy than a similar load having 15% moisture content and, kept in storage in damp conditions, straw will take up moisture from its surroundings. According to Staniforth<sup>(13)</sup> the relationship between moisture content and relative humidity is found to be as follows.

Relative humidity of air	Straw moisture content
95	35
90	30
80	21.5
77	20
70	16
60	12.5

Table 3.5.2a Equilibrium values for straw moisture content at different relative humidities (A R Staniforth)

In fact the relationship is not nearly as simple as the table suggests because the straw moisture content does not change instantaneously with a change in the relative humidity. When the straw is loose and air can circulate freely around it, equilibrium is reached in a matter of hours. However, when straw is in store, tightly packed to reduce spatial requirements to a minimum, the process of taking up or releasing moisture is much slower. In addition, the moisture content increases slightly as the temperature drops and decreases as the temperature rises. Mould begins to form on straw stored in large stacks when the moisture level is above 16%. The foregoing would seem to indicate that it is the moisture content at the time of entering the store which is of most importance and Staniforth cites practical cases where 'dry' straw, with a moisture content of between 10% and 15%, was put immediately into covered stores, protected on the windward side: the bales were found to take up moisture only very slowly, even when the relative humidity was high. Equally, of course, damp straw stored under similar conditions would not dry out quickly.

In the case of straw briquettes, it will become clear that they must be formed at a moisture content below 18% by weight, for the process to be successful. Indeed, the best results will only be achieved if the briquettes are made when the moisture content of the straw is between 12% and 16%. As a result, the moisture content of the stack will be controlled to some extent and the exclusion of additional moisture will be the main requirement of the storage system. Experience has shown that the only certain method of keeping straw dry is to stack it under the cover of permanent buildings. Outside stacks covered with P.V.C. sheeting, for instance, are unlikely to be satisfactory when straw is to be used for fuel.

The ex-farm price of straw varies throughout the heating season and will always be cheaper and most readily available in August. For security of supply, users need to purchase their whole fuel requirements for the season at the time of harvest. Even if the fuel requirements were too large for this to be possible, then for costing purposes the assumption still holds as the storage costs are simply transferred back to the farm or supply depot.

Based on Class 2 agricultural building prices<sup>(16)</sup> the current cost of dutch barn construction is around £25 per square metre of floor area. Cladding on the weather side would add a further 10% to the cost but this is thought to be essential to keep the proportion of spoiled fuel to a minimum.

Table 3.5.2b gives an example of the typical storage costs for straw products of different bulk densities assuming that the total fuel requirement is 700 tonnes; which would, for instance be sufficient fuel to heat glasshouses covering an area of about 5000 m<sup>2</sup> (1/2 ha)



to temperatures suitable for growing long season tomatoes. The prices given are based on the cost of building a new barn store with money borrowed at 12% compound interest. The cost is to be written off in 10 years. Repairs and maintenance are estimated at 2% of the capital cost. No account has been taken of possible government grants or subsidies or the possibility of using space in the barn for other purposes when it is not filled to capacity.

	Conventional Bales	Round Bales	Hesston 4800 Bales	Field-formed Briquettes
Bulk Density (kg/m <sup>3</sup> )	100	65	140	350
Volume Occupied (m <sup>3</sup> )	7,000	10,770	5,000	2,000
Floor Area (m <sup>2</sup> )	1,400	2,154	1,000	400
Capital Cost (£)	38,500	59,235	27,500	11,000
Loan Charge (£)	6,814	10,484	4,867	1,947
Repairs + Maintenance (£)	770	1,185	550	220
Total Annual Cost (£)	7,584	11,669	5,417	2,167
Cost per tonne (£/tonne)	10.83	16.67	7.74	3.09

Table 3.5.2b Comparison of Storage Costs for Straw Products

### 3.5.3 Typical procurement costs

The projected cost of a regular supply of straw fuel products to service an industrial or horticultural heating installation, such as that described in the preceding section, is given by:

The farm-gate price - plus - transportation cost - plus - dry storage cost.

To this must be added a wastage factor which will account for fuel spoiled by rain or broken away and lost as fines during handling. No known figures exist for this untried property, so simple estimates of 5% (bales) and 10% (briquettes) have been made which are high enough to encapsulate, in addition, other minor inaccuracies inherent in the costing model.

	HESSTON BALES		FIELD-FORMED BRIQUETTES	
	Typical	Range	Typical	Range
Farm Gate Price	18	16-22	18	16-22
Transport	10	9-20	3.50	3- 6
Storage	7	4-10	3	2- 5
	35	29-42	24.50	21-33
Wastage	+5%	+5%	+10%	+10%
Total (nearest £1)	37	30-44	27	23-36

Table 3.5.3a Procurement Costs (£ per tonne)

### 3.6 THE COST OF VERY HIGH DENSITY, EXTRUDED STRAW BRIQUETTES

Some mention has been made of a process which makes very good quality briquettes from chopped and ground straw by extrusion through a ring die. The economic viability of this process has always been a matter of some doubt and with oil and coal prices remaining relatively low during the mid-late 1980's, there has hardly been a rush to install the expensive briquetting plant and equipment or embark on a wide marketing operation.

Briquetting of waste material is by no means a recent innovation because sawdust, paper, coal dust, domestic refuse and even old bank notes have been utilised in this very process for many years. Early attempts at using straw in machinery designed for briquetting these other products met with little success and served only to prove what a difficult material straw was to manipulate. These crude trials also clearly indicated that relatively high power inputs would be required for the process to work at all. It was only after the 1970's oil crises that serious development work was attempted and the idea finally began to look at all attractive.

All current plants are either completely immobile or only semi-mobile (towed to the place of work where they are positioned for static operation). Manufacturers projected output rates up to 3 tonnes per hour for large static plants but experience has shown that, in reality, outputs greater than 350 kg per hour are seldom continuously achieved. The most successful machines use a piston or ram to force chopped or ground straw through a ring die in repeated charges. The forces required are immense and much heat is generated so the power consumption is considerable; around 315 MJ/tonne of output (total

including chopping etc.). The briquettes are held under pressure in a die extension for some time after forming, while they cool. A binding agent such as lignosulphate, liquid ammonium or lignin sulphate can be added, at about 3% weight, to increase the throughput and improve the finished product. The density of briquettes formed by this method is generally better than  $1000 \text{ kg/m}^3$  and durability is high.

When the first commercial straw extrusion plants appeared in the early 1980's there was much interest in the cost effectiveness of the systems. Silsoe College conducted a computer based model of the operational costs in 1982/3 for the various contemporary systems on offer and found that straw briquetting was an expensive operation. The figures they offered, included so many unknown variables that it was difficult to generalise about the actual cost of the product. They did find, however, that the three largest components of cost were capital (then about £55000 including bagging plant) labour and power and that the most dramatic reductions in total costs were brought about by increasing the hourly production rates. They recommended that development efforts should be directed towards producing a briquette-making machine at roughly the same cost but with a greatly enhanced output.

In Germany, a study was carried out during 1982 which provided cost information gained from practical experience of operating an extrusion press with straw: a joint enterprise between nine farmers and one non-agricultural partner purchased a briquetting plant with a 40% subsidy from the Hessian State. Their purpose was to cover their own energy demand and to sell briquettes to external customers. They found the operational reliability of the machine to be good and, given an optimal utilisation rate of about 1000 hours per year, they

estimated that the production cost of quality briquettes was 180 DM/tonne or £47 per tonne at the prevailing exchange rate<sup>(14)</sup>.

In the early 1980's with continental oil prices particularly high, farmers in both Denmark and Germany were being actively encouraged to invest in this type of equipment either by grant aid or by example. Local governments actually purchased briquette-making equipment and demonstrated its capabilities to farmers in their region and thus encouraged them to consider investing in their own installation.

Since the first plant was installed in this country in 1982, interest in the continental machinery has increased only very slowly and many of the original marketing companies are now in liquidation. New Air Technical Services of Leicester, who are the U.K. agents for Bavaria briquetting presses retain the largest share of the surviving market. To date, however, only twelve plants have been installed. Operators have co-operated to form the "Straw Briquette Producers Association" and their product, under the brand name Supaglo sells at £75-£110 per tonne depending on the area<sup>(17)</sup>.

New Air claim that developments in machinery for shredding and grinding will reduce overall production costs by ensuring a controlled flow of material through the system with a low expenditure of energy. In 1986 they claimed that a farmer, using their modified system, could expect to make a profit of £25-£52 per tonne with a Bavaria plant producing 900 tonnes per year at a rate of 250 kg/hr., but from this projected profit had to be deducted the cost of any additional buildings to house the machinery and store the straw, insurance costs, additional labour and presumably distribution costs. It can be seen that when these factors are taken into account the margin for the farmer is likely to be very thin.

A second company, who markets Danish made 'Destec' briquetting machines, admits that making briquettes from straw is less cost effective than making fuel from paper or wood waste. Using a 500 kg/hr. machine for 16 hours per day, the manufacturers put the cost of producing straw briquettes at £42 per tonne. Again distribution costs were not included. In 1986, eight Destec briquette making machines were working in the U.K. with capacities up to 1.5 tonnes per hour and any major expansion of their market seems, for the present at least, highly unlikely.

By 1987, the conclusions in the farming press<sup>(18)</sup> were that briquette-making was holding its own against other uses for straw on a small scale but the available static machinery was expensive to run and improved marketing was needed to maintain the momentum. Farming writers also expressed confidence that new machines, such as the one which forms the subject of this thesis, capable of forming briquettes straight from the swath would change the economic outlook but conceded that such machines were still some way from commercial application. Since 1987 the briquette making industry has been in steady decline.

It is clear that briquettes made using current technology cannot compete with other fuels for medium/large scale heating installations at present prices.

### 3.7 COMPARING THE COSTS OF STRAW PRODUCTS WITH THOSE OF FOSSIL FUELS

#### 3.7.1 Primary fuel costs

Table 3.7.1a compares straw products as potential fuel with the major alternatives which are generally available to horticulture or industry for heating plants situated in arable farming regions. The properties

of the fuels, used in calculation of the data presented in this table were those previously quoted in Table 2.8.1a. An absolute costing evaluation would be meaningless because the price of fossil fuel is so variable. During the 1980's, fuel oil prices fluctuated from around £100 per tonne to £200 per tonne and back again. At the time of writing the price was about £140 but it was uncertain where the price would settle. For this reason a range of prices have been quoted for each energy source.

---

MEDIUM FUEL OIL

Purchase Price	£ per tonne	100	120	140*	160	180	200
Gross Energy Cost	£ per GJ	2.33	2.80	3.26	3.73	4.20	4.66
Usable Energy Cost	£ per GJ	3.11	3.73	4.35	4.97	5.6	6.21

COAL

Purchase Price	£ per tonne	50	55	60	65*	70	75
Gross Energy Cost	£ per GJ	1.79	1.96	2.14	2.32	2.50	2.68
Usable Energy Cost	£ per GJ	2.52	2.76	3.01	3.27	3.52	3.77

STRAW PRODUCTS

Purchase Price	£ per tonne	20	25	30	35	40	45
Gross Energy Cost	£ per GJ	1.33	1.67	2.00	2.33	2.66	3.00
Usable Energy Cost	£ per GJ	1.87	2.35	2.82	3.28	3.75	4.23

---

\* The price of oil and coal is subject to large and frequent variations not least because of the distance from the depot and seasonal incentives. At current (August 1988) prices; fuel oil, delivered to a small industrial or agricultural user, is under 12 pence per litre (£130 per tonne) and a similar supply of loose coal costs about £65 per tonne. Domestic, grade 3 coal is £98 per tonne.

Table 3.7.1a Primary energy costs of various industrial fuels.

It can be seen from the table that the primary cost of energy from coal at £65 per tonne is approximately equivalent to straw supplied at £35 per tonne and that this would equate to fuel oil at just over £100 per tonne or about 9 pence per litre.

### 3.7.2 Capital and operational costs of boiler plant installations

The figures in the preceding section would immediately tend to suggest that oil was not competitive with solid fuels. This, however is not the case due to the increased complexity of a solid fuel plant. Whereas oil can be simply piped to a burner either by gravity feed or by a pump from a storage tank, solid fuels must be mechanically handled and stoked into the furnace. Additionally, large quantities of ash and clinker have to be removed from the burner. The alternative to high cost automatic handling systems would be high input of labour but this would only be appropriate on small scale operations. Maintenance costs and controllability for economy would also favour oil fired installations.

An exhaustive treatment of this topic has not been attempted here because it would not be appropriate to generalise on costs which vary so widely according to local conditions such as the availability of land, the scale of the operation and the distance from the supply source. Indeed, it was not the purpose of this project to design or examine a particular plant or process for burning straw fuel; instead it was intended to establish that such installations could be viable for a variety of applications if the prevailing conditions were favourable. Both oil and coal fired furnaces are in regular use on many agricultural, horticultural and light industrial heating systems and, depending upon the particular conditions of the installation,



either fuel could prove to be the more economical. It would be logical to assume that straw fuelled systems would be favoured in areas of concentrated arable farming, where not only is the raw material abundant but also the additional land and building resources to cope with the extra bulk tend to be both available and reasonably priced.

The handling and stoking problems associated with straw briquettes would, in many ways resemble those encountered on other solid fuel systems burning coal or coal products. Hence, there would be no reason to suppose that the capital cost of the boiler, furnace and fuel handling equipment should be significantly different, for any given application, once the market had become established. Additional dry storage space would, however, be required due to the increased bulk of the fuel and its vulnerability to wet conditions. The capital cost of these buildings should be included in the costing model.

If low density baled straw is to be considered for fuel, then the furnace and handling equipment required would be much more costly and additional penalties in the form of lower combustion efficiency and even greater storage requirements would be inevitable. Big bale burners and their associated equipment are necessarily very large and presently have only a limited market which is undergoing only a very gradual expansion. The other alternative; using chopped straw supplied as bales then tub ground and blown into a temporary silo before being conveyed into a furnace, has added complexity and requires additional power inputs in return for an improved efficiency of combustion. This type of automatic stoking device will add at least £6000 to the capital cost of the boiler system if the furnace is a large one with an output of, say 500 MJ per hour. The annual charge

to write off £6000 compounded at 12% over ten years, for instance, is just over £1000; for a boiler with a total utilised output of 1000 GJ this would add a cost of £1 per GJ. Therefore, it is unlikely that automatic chopping and stoking would be economically justifiable on boilers of relatively low output.

As an illustration of the capital costs involved, Table 3.7.2a compares the use of straw products with the alternatives for one particular example of which price information could be readily obtained<sup>(19)</sup>. The capital investment for a briquette fired plant has been added accordingly to the predictions, discussed above.

It must be noted that the British Government would be likely to provide incentives to the user, in the form of capital grants, if economical straw fuel packages became available; these have been excluded from the calculations because they are, as yet, an unknown factor.

	Capital Equipment	Estimated Building Cost	Total Capital	Annual Capital Charge*
	(£)	(£)	(£)	(£)
Oil	17500	5500	23000	4070
Coal	38000	5500	43500	7700
Straw (baled)	65000	22000	87000	15400
Straw (field briquette)	38000	15000	53000	9380

\* assumed 12% interest : written off over 10 years

Table 3.7.2a Comparison of installation costs for new boiler plant of 1 MW rating : suitable to heat a 4000 m<sup>2</sup> greenhouse.

### 3.7.3 Annual costs: typical example

It would seem, that there are simply too many variables that a single price could be quoted at which straw products, be they bales, extruded wafers or medium density field-formed briquettes would become competitive as a fuel; instead a particular example of a medium scale industrial/horticultural fuel user has been cited below and various fuels compared. This example typifies the sort of consumer who would most benefit from considering straw as an alternative fuel source and is consistent with the favourable conditions which have been referred to in the preceding subsections. The intermediate values used to compile this summary are those previously quoted in Tables 2.8.1a, 3.5.3a and 3.7.2a.

	FUEL			
	COAL	OIL	STRAW (Hesston Bales)	STRAW (Field Briquettes)
Energy Output (GJ)	7500	7500	7500	7500
Required Energy Input (GJ)	10560	10000	11720	10560
Fuel Quantity (tonnes)	377	233	781	704
Capital Investment (£)	43500	23000	87000	53000
Procured Fuel Cost (£)	24500	33790	28116	18304
Annual Capital Charge (£)	7700	4070	15400	9380
Additional Labour & Power Over Oil (£)	500	-	1000	500
Total Annual Cost (£)	32700	37860	44516	28184

Table 3.7.3a Example of Comparative Annual Operating Costs for a Typical 1 MW Heating Installation

### 3.8 VIABILITY

It is clear from the example given in 3.6.3 that there are applications for which burning straw briquettes, of the forecast unit density (approximately  $600\text{kg/m}^3$ ) on an industrial scale would be economically viable as well as environmentally desirable. Examples could also be taken of consumers requiring either a much greater or a rather smaller heat generation capacity but the economics would need a separate evaluation in every case.

Large users, for instance, would have the buying power to procure existing fuels at more competitive prices than small or medium-scale operators. Prices down to, perhaps half the price determined for this example might apply, particularly at a time when fossil fuels are in surplus. They are, however, unlikely to obtain similar reductions in the price of straw products because the farmer would not be prepared to produce at a loss and would simply revert to field burning or incorporation as a means of straw removal.

For relatively small applications or on-farm consumption, on the other hand, straw briquettes for fuel look particularly attractive and would be made even more so in the likely event that National or European government were to support a newly available field-briquetting technology. Encouragement could be provided either in the form of capital grants or by introducing even tighter field-burning control legislation.

It would seem, therefore, that the main obstacle, which has so far prevented the more widespread use of straw as fuel, is the lack of an appropriate technology.

#### 4. TECHNOLOGICAL FOUNDATION FOR THE RESEARCH

##### 4.1 SURVEY OF TECHNICAL LITERATURE AVAILABLE AT THE COMMENCEMENT OF THE STUDY

Interest in compaction of fibrous agricultural materials appears to have begun, in earnest, in the mid 1950's. A number of learned papers were published between then and 1968. Early work\* deals mainly with forage crops like hay and lucerne and largely originates from the USA. Renewed interest in recent years, which has been focused on straw compaction for fuel, has been encouraged by both environmental lobbies and escalating fossil fuel prices. Most of the recent work has been carried out in the United Kingdom and on the Continent of Europe.

In the United Kingdom, the National Institute of Agricultural Engineering, now known as the Agricultural and Food Research Council, (A.F.R.C. Engineering) at Silsoe, in association with the Cranfield Institute of Technology, carried out some fundamental research during the mid 1970's which has continued through the 1980's. As had been the case with the earlier forage crop researchers, two distinctly different approaches were examined, in parallel, to achieve the required densification;

extrusion through a ring die; and  
compaction within a closed cylinder.

Quite naturally, early work\*\* on straw compaction relied heavily on the existing technology for wafering or pelletising forage crops and residues but although the two types of fibres are not entirely dissimilar, greater difficulties were always encountered by researchers processing straw. Higher forming pressures, coupled with lower briquette stability and increased frictional losses resulted in

\* Reviewed in subsections 4.1.1 and 4.1.3  
\*\* Reviewed in subsections 4.1.2 and 4.1.4

increased energy inputs and reduced throughput rates. In 1977, Smith et al<sup>(15)</sup> suggested that the compaction and stabilisation of straw may have an unknown mechanism that differs from that occurring with forage. Nevertheless, interested parties continued to believe that the technology applicable to forage densification must be directly transferable. Those machinery manufacturers who have investigated straw briquetting appear to have concentrated on adapting plant and equipment which was originally designed to process animal feeds, sawdust or wood-shavings rather than attempting to design purpose-made equipment from scratch<sup>(19)</sup>.

Clearly, technical information relating to hay and other forage crops is of some interest here but, in order to gain a true assessment of the current state of knowledge on the subject, it will be treated separately to research data concerning straw behaviour.

#### 4.1.1 Extrusion through ring dies: forage crops.

Wafering forage crops has been technically successful in practice using both static and mobile extrusion presses. These became commercially available in the USA from the early 1960's. International Harvester, Massey-Ferguson, Lundell, Cal-Cube and J Deere & Co. all either developed prototypes or had limited production runs of such machines. According to Curley, Dobie and Parsons<sup>(21)</sup> there were about 130 field machines and 10 stationary machines in operation in California alone by 1970 but this initial enthusiasm has not been maintained.

The operation of field wafering machines was described by Lundell and Hull<sup>(22)</sup> and Poore et al<sup>(23)</sup> both working with lucerne (alfalfa

grass). Lundell suggested that a 125hp dedicated engine would be sufficient to produce forage wafers with a bulk density of  $400\text{kg/m}^3$  at a capacity of 5-6 tons/hr. and that the optimum moisture content for wafering was between 14% and 18%. Poore found that wafer density was fairly constant up to 15% moisture content but wafers were less dense when they were formed at higher moisture contents. It is interesting to note, however, that both machines were fitted with moisturising sprays to maintain a constant wetness. The specific power requirement of this type of machine was found to be quite high at between 50 and 100 MJ/tonne<sup>(24)</sup>.

Dobie<sup>(25)</sup> had previously found that the moisture content of the crop was critical for successful wafering and that it should be between 12% and 15% by weight; wet basis. He considered that this would be a large bar to field wafering. Cade<sup>(26)</sup> had been more optimistic when he revealed that the moisture content restrictions were not common to all forage crops. He found that there was a wide range of moisture contents at which different crops could be wafered satisfactorily (9% to 31%).

#### 4.1.2 Extrusion through ring dies: straw.

Although, quite recently, static extrusion presses of various types have been commercially adapted for processing chopped and ground straw (see section 3.5), no corresponding evidence could be found that field-briquetting straw in this way has been either technically or economically proven. Indeed, Chaplin<sup>(27)</sup>, pressing straw in the laboratory with a reciprocating ram and ring dies, recorded excessive specific energy requirements (200-400 MJ/tonne) and a maximum production rate of only 0.2 tonne/hr. He concluded that pre-chopping

and the addition of a binding agent would be needed to maintain briquette stability suitable for mechanical handling.

Researchers all agreed that, to be economically viable, straw processing machines would need work-rates comparable with existing farm machinery. In 1980, Hawkins<sup>(20)</sup> wrote that he saw no future for contemporary briquetting machines which, he said, required about 10 times as much energy as balers and often had only 1/50th of the output. At the same time, Klinner and Knight<sup>(28)</sup> declared that unless major improvements could be made to increase machine capacity and reduce the power requirement of briquetting presses, less dense forms of straw packaging would continue to be preferred for some time to come.

#### 4.1.3 Compaction within closed cylinders: forage crops.

In 1955, Bruhn<sup>(29)</sup> had conducted laboratory experiments on forage crops and grain mixtures which showed that feed wafers could be made using the closed die process without the use of binding agents. He identified 28-42 MN/m<sup>2</sup> as the most practical range of loading pressures and that leafy legumes made the best wafers. Four years later, Butler and McColley<sup>(30)</sup> conducted detailed experiments with closed dies confirming Bruhn's findings. They added that, although expansion occurs immediately on release of the load and the sample continues to grow significantly during the next 15 minutes, the movement is negligible after 30 minutes and that best results were obtained if the material was held under load for about five seconds.

Bellinger and McColley<sup>(31)</sup> investigated the energy requirements of the closed die process and found that it could potentially require much



smaller inputs than the extrusion process. They observed a total power consumption of typically 14 - 22 MJ/tonne in the laboratory of which 15% was required for extraction of the briquettes. In his more recent publication on the same topic, Reece<sup>(24)</sup> suggested that the power requirement for this process could be as little as 11 MJ/tonne.

Clearly processing machines using the closed die principle would have a great advantage over extruders in terms of power consumption. Mobile implements would particularly benefit. However, the mechanical problems of applying this principle economically to a continuous process machine with an adequate throughput have, so far, been overwhelming. While forage wafering machines might be economically viable with a slightly smaller processing capacity than straw briquetters because of their higher product value, 6 tonnes per hour would not be an unrealistic minimum capacity. Assuming this and an average 80g wafer size, a rate of over 20 wafers per second would still be called for.

One consequence of a high throughput would automatically be a reduced time for the compression stroke with little or no dwell time. Chancellor<sup>(32)</sup> addressed the possibility of compressing hay with impact loads and discovered that wafer formation was less efficient than by static loading. Energy inputs equivalent to 28 MJ/tonne proved relatively ineffective in his high speed laboratory experiments. No information could be found, however, about the effects of intermediate speed compression using speeds related to field production rates.

In all the foregoing research papers the quality of wafers was not clearly quantified but it would be fair to say that these 'low energy' products were of a generally inferior durability and appearance to the

more energy intensive extruded cubes. Many researchers commented that results varied substantially with different hay types. Shepperson and Grundy<sup>(33)</sup> went further when they concluded that the crop type had a greater influence on wafer density than did the loading conditions. Crops with a high proportion of legumes or a high leaf to stem ratio, they said, would always produce superior wafers. When assessing the product, however, it must be remembered that the ultimate test for the quality of forage wafers is their suitability as cattle feed. Unlike straw briquettes, therefore, there would be a density limit beyond which the product would become unpalatable.

#### 4.1.4 Compaction within closed cylinders: straw.

Cereal straw has a very low leaf to stem ratio so, according to the above observations, it would be unreasonable to expect it to perform as well as the best suited forage crops. It is, however, notoriously difficult to predict the mechanical behaviour of these anisotropic and inhomogeneous fibres. Back in 1958, Mewes<sup>(34)</sup> attempted a mathematical analysis of straw under compression in closed chambers based on his own empirical data. His work was confined to relatively low pressures (under  $7 \text{ MN/m}^2$ ) and is, therefore, only likely to be directly applicable to contemporary baling technology. Investigating the properties and behaviour of straw in general, however, he made several useful observations. He measured substantial forces transmitted sideways onto stationary compression chamber walls and proposed different mathematical relationships for both loading and unloading. From his experimental work he deduced that it was reasonable to consider that pressure was evenly distributed across the loaded cross section when a flat-faced ram was used. In addition, he speculated that the coefficient of friction for the hay/straw material

might not be constant, even when the interacting materials were defined and that friction was not likely to be independent of pressure level or compaction speed.

The first publication which confirmed that raw straw could be pressed into stable briquettes by direct compression did not appear until 1977. In their publication, Smith et al<sup>(15)</sup> demonstrated that whole-straw could be compressed and stabilised without binding agents or other mechanical aids and reported the energy input to be only about 6% of the calorific value of the material. They found that when straw is loaded to between 50 and 60 MN/m<sup>2</sup> in a closed cylinder, it would relax on release of the load but would remain together as a cohesive and relatively dense and durable package. The quality of the package also depended on the moisture content of the straw used.

Published research information relating to straw briquettes formed by the closed die process was, therefore very limited both in quantity and in depth of coverage at the time this project commenced. This most promising method of production had, apparently either been overlooked or had been rejected during preliminary investigations because of the undoubted complexity of the high speed machinery that the process implied.

#### 4.2 EARLY WORK AT LOUGHBOROUGH

Staff of the Department of Mechanical Engineering at Loughborough University of Technology were first approached during 1982 in connection with straw compaction technology. An established expertise and a first class technical reputation in applied high speed machine

design associated with flexible textile fibres had been instrumental in winning a small preliminary research contract to investigate possibilities for field machinery to produce fuel briquettes from straw. The contract was sponsored by the Howard Rotavator Co. Ltd.

The author is indebted to colleagues and students who did much to establish some important basic machine concepts during the first year of the project, prior to the commencement of his own work. The following sections attempt to summarise their, as yet unpublished work.

#### 4.2.1 Broomhall's Work

As a postgraduate student in the Department of Mechanical Engineering during 1982/3 Mr Keith Broomhall investigated, experimentally, the feasibility of several novel concepts for producing dense straw packages at continuous high speeds. Unfortunately, the results of this work were never accurately documented. However, it is known that he was able to dismiss both rolling and twisting (spinning) as unsatisfactory production methods by using simple specially designed laboratory test rigs. Plate 4.1 shows typical examples of high density straw packages formed by these methods. He went on to look more closely at direct compression between dies. Using a simple test rig in an hydraulic press, he compacted whole straw at about  $50 \text{ MN/m}^2$  in a rectangular cavity and formed moderately dense rectangular briquettes measuring approximately 60mm X 40mm X 25mm and weighing around 100g. Finally, he conducted preliminary experiments to check the validity of the proposals referred to later in section 4.2.3.

#### 4.2.2 Undergraduate Project

In their final year at University, Barber, Bingham and Brett looked at the feasibility of designing a Tractor Drawn Straw Briquetting machine and conducted a theoretical design study on elements of such a machine. Their chosen solution employed multiple reciprocating rams in closed cylinders. After serious consideration they conceded that their design study had not provided the basis of a viable machine. They discussed major difficulties they perceived with intermittent feeding and ejection under high operating force conditions and expressed doubts that their preferred concept could ever be made to work reliably at field production rates. They suggested that further work should be directed to employ different principles.

#### 4.2.3 Staff Contribution

At an early stage, three alternative inspired principles for uninterrupted compaction and separation of briquettes using continuously rotating machinery were suggested by the project supervisor, Professor R Vitols, (then Reader in Engineering Design). These ideas became the conceptual foundation of the machine towards which this research is directed and will be examined in some detail in Chapter 6. At this early stage of the project, much help and support was also provided by Broomhall's joint supervisor, Mr J E Baker, Senior Lecturer in Design (now retired).

#### 4.3 PARALLEL RESEARCH

In addition to the project referred to in section 4.2.2, the author and colleagues have supervised a large number of further undergraduate

research and design projects between 1983 and 1990 concerning various aspects of straw processing, some of these are referenced individually at the appropriate points in the text.

Increased external activity, has been observed throughout the period of research which has been directed towards solution of the problem of straw disposal. Particularly notable contributors have been O'Dogherty and Wheeler<sup>(35)</sup> and Neale<sup>(36,37)</sup> of the A.F.R.C. whose results provide useful comparisons to the author's research. Their published work, along with that of other recent contributors is referred to at the appropriate points in the text which follows.

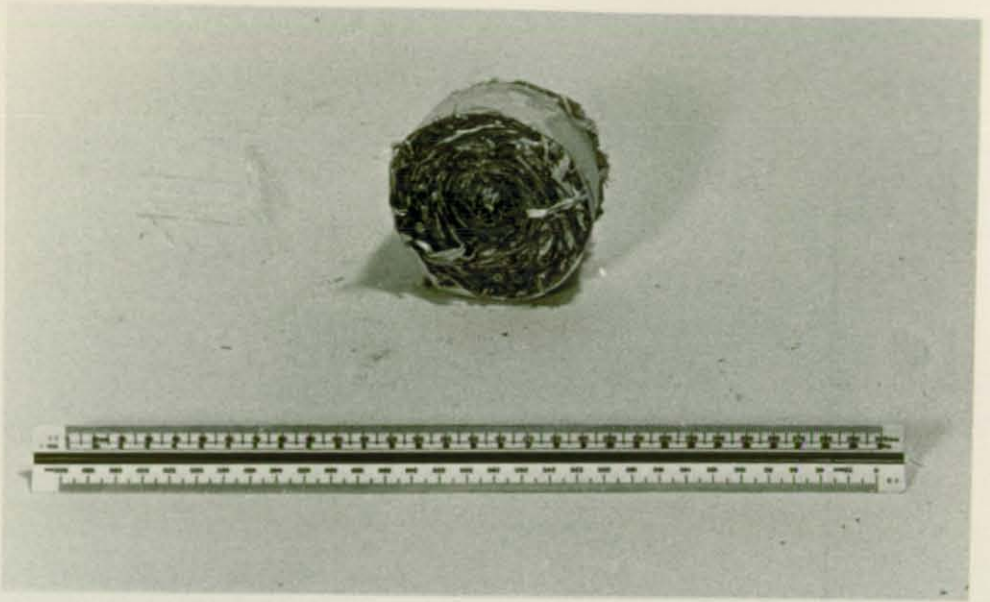

(a) Rolled Straw Package (note external restraint)



(b) Twisted Straw 'Rope'

## 5. SPECIFICATION OF THE PROPOSED FIELD-BRIQUETTING MACHINE

To this point, the author has considered the economic argument outlining the scope for developing a straw briquetting machine. In addition, the available technical data relevant to the capabilities and requirements for the production of machine handlable fuel briquettes has been thoroughly searched and reviewed. Possibilities for the introduction of new machine technology have been highlighted but several areas of limited fundamental knowledge have been exposed.

It has become clear that the design of briquette-making machinery is no easy task, and that, if such machines are to be successful, they are likely to require untried concepts and that these concepts will only work effectively if the associated design is optimised. If all this is to be achieved, a thorough understanding of the behaviour of the working material will be essential.

Attention will henceforth be focused upon the practicalities of innovating new straw processing machinery which meets the identified need. The primary function of any new machine would be to collect straw directly from the windrow and convert it into small dense and durable packages. It would take its power from a conventional tractor behind which it would trail. These essential features place major constraints upon the design.

The following requirements have been established by economic consideration and most were discussed, in some detail, in chapter 3.



## 5.1 PERFORMANCE

(i) The machine will be required to lift loose straw from the cut swath as it lies in the field and discharge briquettes into suitable bulk transport.

(ii) A processing capacity of between 6 and 10 tonnes per hour will be required.

(iii) The individual briquette size is to be between 20 and 200 cm<sup>3</sup>

(iv) The bulk density of briquettes should be greater than 270 kg/m<sup>3</sup> and ideally 430 kg/m<sup>3</sup> for optimum transport efficiency.

(v) The power available for the process will be restricted to the output of a large agricultural tractor - around 80 kW.

(vi) Briquette quality will be mainly determined by their stability in transit. Briquettes should be sufficiently durable for mechanical handling. Appearance is of only secondary importance.

A durability rating for briquettes will be established using the method described in A.S.A.E. standard S269.3 - Wafers, Pellets and Crumbles: Definitions and methods for determining Density, Durability and Moisture Content. Using this method, a durability rating not less than 95 will be needed (5% max. loss of weight after tumbling for 3 minutes in the specified apparatus).

## 5.2 TARGET COST

The target retail price of the briquetting machine should be £42 000 which infers that the factory cost of the product would need to be less than £30 000.

## 5.3 SIZE AND WEIGHT

Limited by highways regulations, in particular B.S. 6508 Track widths for Agricultural Equipment. Clearly this machine would have to be comparable in size with existing trailed implements.

## 5.4 ENVIRONMENT AND USAGE

(i) The machine will be heavily used during the harvesting season July to September (U.K.) but kept in storage for most of the remaining months.

(ii) The climate will vary according to the region but no special conditions will prevail. Typically a mixture of sun, winds up to 20 m.p.h., rain and mist with temperatures between 10°C and 30°C.

(iii) The machine may be required for additional use in a static mode under a covered barn during the winter which infers temperatures will fall to, say -5°C.

(iv) Mud, dust, sand, dirt and plant particles will all be present in profusion.

(v) The principal working surface will be very uneven and soft with

ruts and loose stones. Secondary surface will be smooth tarmacadam (in transit).

## 5.5 LIFE IN SERVICE

(i) The machine will be operated by semi-skilled labour.

(ii) A high degree of abuse will be likely.

(iii) The designed service life should be 10 years.

(iv) The primary use will be approximately 8 hours per day 6 days per week for 2 months. Secondary use is estimated at 4 hours per day for 1 month. Hence total service life would be approximately 5000 hours.

## 5.6 MAINTENANCE

Only an annual, pre-season routine service requirement would be practicable, this could include, for example, setting adjustments, changes of lubricating oils, general cleaning and renewal of minor consumable parts. In addition to this simple weekly lubrication during the season would be feasible though undesirable.

## 5.7 COMPETITION

No field-briquetting machines are currently in production, however, competing machinery is presently at an early stage of research and development at A.F.R.C., Silsoe. Earlier attempts at adapting the extrusion process to a fully mobile machine have, so far proved unsatisfactory. The process will have to compete with alternative

methods of straw disposal namely burning, incorporation and baling (discussed fully in Chapters 2 and 3).

The fuel product will be in competition with existing fossil fuels like oil, coal and gas and to a lesser extent with straw which has been supplied in a different form: extruded briquettes from static machines or low density baled and chopped straw.

### 5.8 PRODUCTION QUANTITY

With a product which would involve a major re-shaping of well established methods, growth in popularity of the field-briquetting process would, quite likely be quite slow and depend largely on the proven effectiveness of the first production machines.

The current U.K. baler market is around 2 200 units per annum; considering the possible advantages of the new process a 15 per cent share in this market, equivalent to 330 units would be a modest expectation in the medium term. In the long term, if foreign markets particularly in North America and Scandinavia could be convinced of the effectiveness of the system the ultimate potential is very large indeed. The possibilities for the process in the energy deficient Third World are also unknown at this stage but must surely provide a wealth of opportunity.

### 5.9 AESTHETICS, APPEARANCE AND FINISH

Aesthetics and appearance are of minor importance and in the final design, a briquetting machine would most probably be styled to give a family identity with the manufacturers existing range of products by

the appropriate application of paints and emblems onto shaped enclosure panels.

#### 5.10 ERGONOMICS

The machine would have to be compatible with all common agricultural tractors rated at more than 80 kW. The control interface must be easily understood by the operator and multi-lingual display symbols would be preferred to text. Controls should be robust and capable of operation with gloved hands. They should also be resistant to dust and grime.

#### 5.11 THE CUSTOMER

Assuming the product would be first launched in the U.K., the target customers would initially be haulage or plant contractors who operate machine hire services, however, the machine should ultimately be aimed to meet the needs of Farm Managers who control large arable farms. Only when the product began to be established would the marketing effort be extended to smaller private farmers with a view to on-farm consumption of the straw fuel.

#### 5.12 STORAGE CONDITIONS

It is anticipated that the machine would most likely be stored under the shelter of an open-sided implement shed throughout the winter months.

### 5.13 SAFETY

Sharp corners or edges near the operator's path should be eliminated or shielded.

Moving parts capable of causing injury such as rotating shafts, chains, belts, gears or fast moving projections should be guarded or located out of reach as much as possible, without interfering with the function of the machine.

Safety warnings should be prominently placed where needed. They should be positioned where they would not be easily obscured by dirt or falling dust.

Any climbing steps for access to lubricate, adjust or inspect should be non-skid and supplemented with hand-hole.

Unclogging, with the machine rotating, should be discouraged by warning signs and the necessity eliminated by the provision of reversing controls, roll adjustment controls etc. operable from the seat.

### 5.14 POLITICAL AND SOCIAL IMPLICATIONS

The existence of an economically viable straw disposal/utilisation system would further encourage tightening of straw burning laws which now seems inevitable in any case. The existence of a new technology would make the changes more acceptable to the farming community. Revised legislation would, in turn, give added impetus to the market for the process, as severe restriction or even the total elimination

of a major competing disposal method would undoubtedly make briquetting very much more attractive. With the current climate of environmental awareness which has been experienced at the end of the 1980's, possible government or E.E.C. grant aid for conversion to renewable energy sources seem to be distinct future possibilities. Further developments will, however, be driven by the technology.

## 6. MACHINE SYNTHESIS AND PRELIMINARY EXPERIMENTS

### 6.1 PRINCIPLES OF COMPACTION

Five basic modes of compaction are considered, in summary:

Extrusion; Current commercial straw briquetting machines and many types of pelleting devices for 'wet' composites employ this well tried principle but the documentary evidence (Clauses 4.1.1 & 2) suggests that this manufacturing method could neither meet the power nor the processing capacity constraints defined in the specification.

Direct Compaction; The second of the two classic solutions has been tried in the laboratory with the crops constrained in closed cylinders. The documentary evidence (Clauses 4.1.3,4 & 4.2.2) suggests that although direct compaction might meet the Power requirement, the closed cylinder approach has major drawbacks and the complexity of a high capacity machine would make it too costly in practice.

Roll binding; A fast continuous process used extensively in low density baling, the rolling principle was tried in early work at Loughborough (Clause 4.2.1). High density rolled packages do not, inherently, possess the bonds required to maintain stable briquettes when released from the processing machinery (see chapter 7). The possibility of providing individual external restraints for each briquette seems unlikely.

Twisting; Twisting or spinning in the manner of a rope or yarn was also found to be an unpromising solution when tried at Loughborough



(Clause 4.2.1). separation into individual briquettes would add further unsolved problems of a high order.

Evacuation; Klinner and Chaplin<sup>(38)</sup> investigated straw densification by evacuation to 80% vacuum\* in hermetically sealed wrappings with indifferent results. We can conclude, however, from their work that a much larger pressure difference than this would be required to meet the density requirement. That the process is unlikely to lend itself to high speed briquette production is a matter for speculation but the many obvious problems are not encouraging.

## 6.2 MACHINE CONCEPTS

Clearly none of the above principles would provide an instant solution to the design problem and a new concept, which selectively explored the positive features from more than one of the tried methods would be needed.

### 6.2.1 The Radial Disc Compactor

The undeniable advantage of direct compaction, using closed dies, in terms of power requirement was the overriding factor which dictated that the effort should be concentrated upon adapting this principle to continuous production. It was felt that previous studies had always foundered because straw was separated into discrete packages in its loose state and then injected into a compression chamber of some sort ready for the work to be done on them. It had then to be ejected before the next charge was loaded. Handling the bulky material mechanically to give an output of tens of briquettes per second was found to be practically impossible.

\* 0.2 x Ambient Pressure

An alternative direct compaction system might be to compress the raw material into some sort of continuous 'rope' at the required density and perform the separation as a subsequent operation.

Continuous compaction suggests a form of rolling must be used where the compaction force could be sustained by rigidly mounted bearings and the separation requirement suggests either a cutting or a shearing action would be required. The "Radial Disc Compactor" concept was, therefore, devised where compaction and separation would take place simultaneously. The concept, illustrated in figure 6.2.1a would demand that straw be continuously fed. Ideally straw would pass between the rollers at exactly the same rate that it enters the machine, i.e. there would be no compression in the direction of flow. Any deviation from this would infer that either longitudinal compression or tension would take place which would inevitably consume additional power.

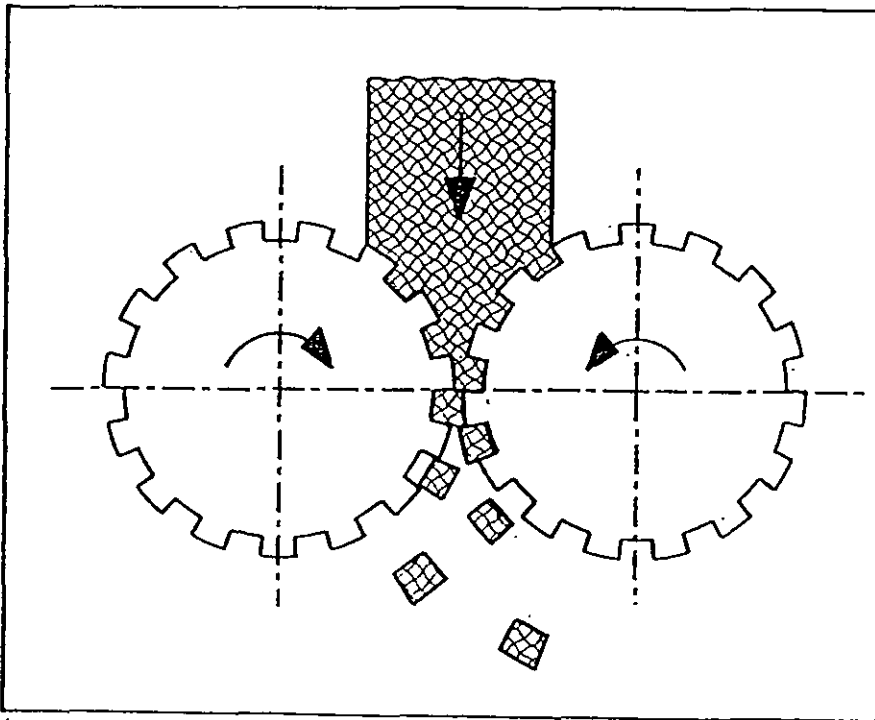

Figure 6.2.1a The Radial Disc Compactor Concept.

### 6.2.2 The Conical Disc Compactor

Although untried at the time, the idea of a continuous compaction and separation process, such as that described above, looked very attractive even though several possible flaws in the scheme were immediately apparent. In order to perform a proper synthesis of the design solution it would be necessary to fully explore the potential of the basic scenario by considering possible variations on this continuous process concept.

An alternative solution would be to compress the swath between two rotating cones with their principal axes inclined such that the conical surfaces lie parallel at the nip point. (see figure 6.2.2a and plate 6.1). Steps or die-pockets could be arranged around the interacting surfaces in the same manner as with the Radial Disc Compactor.

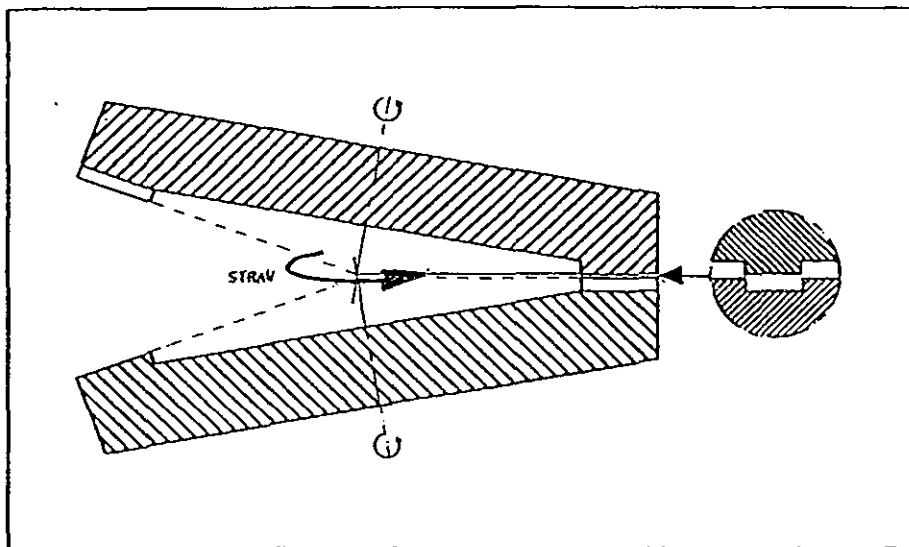

Figure 6.2.2a Conical Disc Compactor.

This arrangement would appear to offer two advantages over the radial disc system. Firstly, the design would lend itself to a more compact arrangement and secondly, the compression ratio of the machine could be adjusted by selecting a different angle of inclination between the discs. Hence, for any particular disc diameter the rate of compaction could be altered in relation to the throughput speed: for example, if the discs were assumed to be inclined at  $20^{\circ}$  to each other; the rate of loading of the straw for a conical disc arrangement would be only 17 per cent of that for a radial compactor of the same disc diameter (see Appendix II,[3] ).

The main drawback of the proposal would be considerably increased complexity, particularly in view of the more complicated arrangement which would be required to feed straw into the die pockets without spillage and to provide suitable transmission of the driving torque. The supporting framework would also be more complex as the straw compaction load could no longer be carried by members in direct tension.

### 6.2.3 Converging Slideways

A third possibility would use a pair of convergent conveyers to provide the continuous compaction. The conveyers would, in fact, be made up of many adjacent dies with the ability to be displaced individually by a small distance under the action, perhaps, of a fixed cam plate. The sliding displacement of the dies would be arranged to take place at the point of maximum compression, the distance displaced being that found necessary to completely shear the compressed straw 'rope' into briquettes. The design would be considerably more complicated than both the other two options but offers the possibility

of holding the straw under maximum compression for a long period, together with a superior shearing condition.

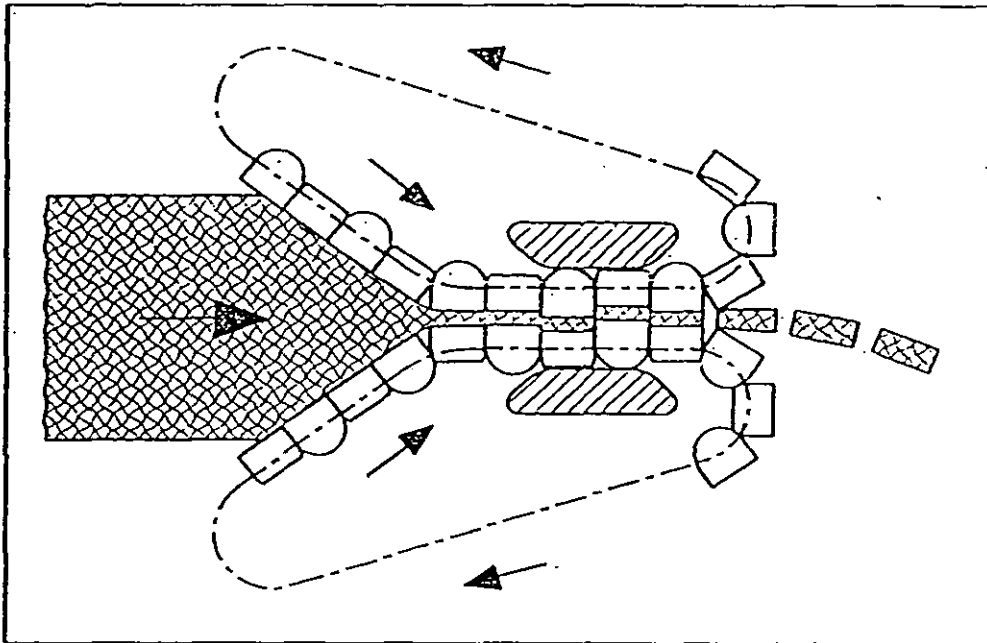

Figure 6.2.3a Converging Slideways

The essential difference between the Converging Slideway concept and the other two alternatives is that shearing would take place after the straw had been compressed into a very tightly compacted 'rope' and not during the process of compression. At maximum compression there would be little possibility of the fibres moving within the dies under the action of separation. It is likely, therefore, that a relatively small displacement of the dies would be sufficient to completely shear through the mass. With both the Radial Disc and Conical Disc compactors it is less obvious how the straw would move inside the die sections and, therefore, less predictable that the briquettes could be cleanly separated without the two halves of the dies actually coming into contact.

## 6.3 EXPERIMENTAL EVALUATION OF THE CONCEPTS

### Objectives

The following section describes a series of simple laboratory experiments which were devised to test the foregoing ideas against the primary process constraints. The experimentation would hopefully verify that raw straw could be made into durable briquettes by simple compression, as had been shown by earlier researchers, and provide some additional information which would enable a decision on the technical feasibility of the proposals to be made. In particular, a first order estimation of the power requirement for the process was needed together with proof that compressed straw would shear into individual packages under the action of teeth or dies which were not to touch or overlap in a scissor-like fashion but simply to come into close proximity with each other.

These initial experiments would also prove invaluable in highlighting some of the secondary requirements of the system which had not been immediately apparent.

#### 6.3.1 Closed Cylindrical Die Experiment

Figure 6.3.1a describes the simple closed cylindrical die apparatus constructed in mild steel for the verification experiment. The equipment closely resembled that described by O'Dogherty and Wheeler in their earlier work<sup>(35)</sup>. The diameter of the cylinder was 50mm and its length was approximately 250mm. Pressure was applied directly to the plunger by means of a Denison 50 Ton hydraulic tensile/compressive testing machine.

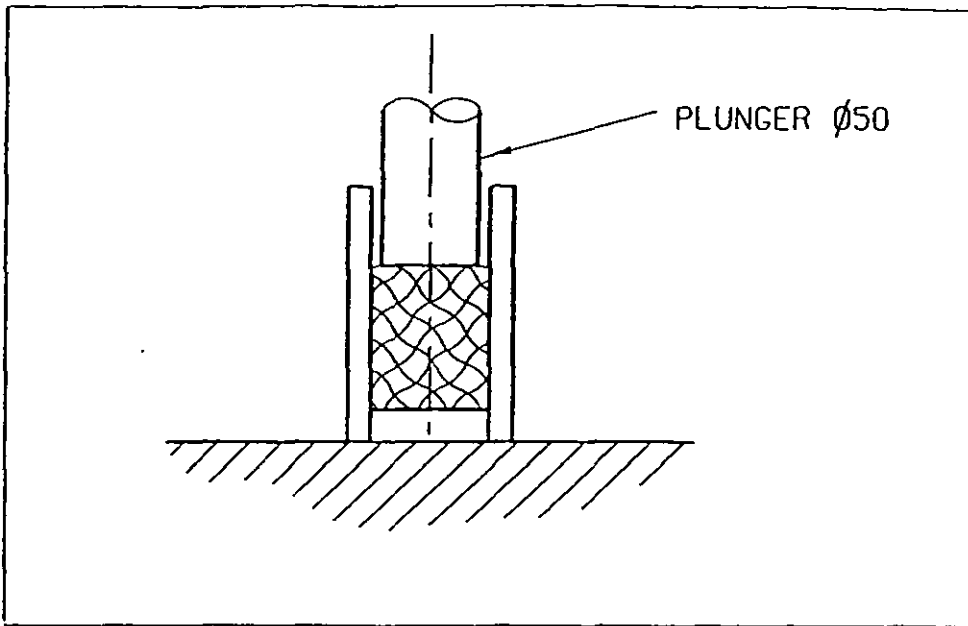

Figure 6.3.1a. Closed Cylinder Apparatus.

#### Experimental Method

The die cavity was filled to capacity by hand with fresh (baled) wheat straw in a random manner. The plunger was guided into the end of the cylinder and a known force applied; during the compression stroke readings of load and displacement were taken at appropriate intervals. On release of the load, the base of the apparatus was removed and the compressed straw package was forcefully ejected. The briquette was weighed and its visible qualities noted. The experiment was repeated at several different pressure levels and graphs of applied pressure against compressed volume plotted using the mean values from several tests.

## Observations

Straw packages were formed using pressures from  $0.6 \text{ MN/m}^2$  to  $40 \text{ MN/m}^2$ . In each case the maximum pressure was held for around 30 seconds and the load was applied slowly and steadily throughout the compression period. Upon sudden release of the load, the heavy plunger was forced back up the compression cylinder at least 5mm under the reaction of the straw and the package expanded further on removal from the die cavity. By far the greater part of this relaxation took place in the direction of loading but the samples pressed with light loads also exhibited significant sideways relaxation.

Packages formed at the lower end of the pressure range were, in fact, completely unstable and began to disintegrate within a very few seconds. It was clear that density and stability improved with increased pressure and at the higher end of the experimental range the product could be said subjectively to be a "durable briquette". Below  $20 \text{ MN/m}^2$  no cohesive wafer could be formed and the gains in density were found with increasing pressure.

It was noticeable that the quality of the briquettes was affected by the amount of care taken in loading the apparatus. For instance, if straw was loaded into the cylinder in small quantities, pressed down by hand and then more straw added up to the desired weight, the briquettes were significantly less stable than those which had been made from straw loaded into the cylinder as a single coherent package.

## Results

Figure 6.3.1b indicates the general form by which the volume of the



compressed mass varies with applied pressure. It indicates that the compression cycle may be conveniently split into two regions: firstly there is a period of relatively large movement at low pressure and this is followed by the high pressure region where small movements lead to large rises in the reactive force. The work done over the compression cycle for briquettes made at  $40 \text{ MN/m}^2$  was calculated as 570 Joules with an average sample mass of 31 grammes which gives a protracted specific energy requirement of 18.4 MJ/Tonne. Some 65% of the energy input being absorbed over the last 10% of the stroke.

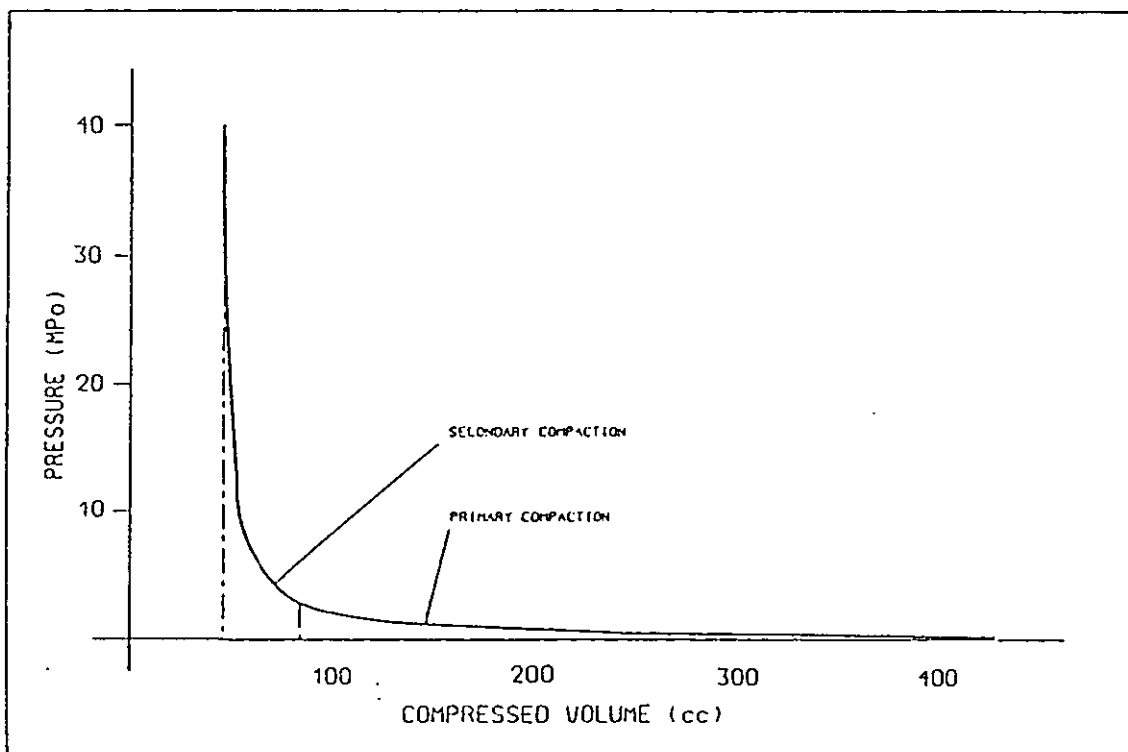

Figure 6.3.1b Typical Loading Curve for Straw briquettes.

### 6.3.2. Closed Rectangular Die Experiments

Practical machinery employing the concepts described in section 6.2 could not use a cylindrical die shape nor could such a machine maintain the pressure for such a long period so it was important that test equipment should be developed which more faithfully represented the conceived field machine. The first stage of this investigation was to repeat the cylindrical die tests with a rig forming a rectangular cavity. The sizes were arbitrarily chosen (55mm X 65mm) but based upon specification requirement 5.1(iii). It was assumed that a desirable and commercially usable product would be approximately a 60mm cube weighing up to 100 grammes. The unit density would need to be no less than  $500 \text{ kg/m}^3$  to conform to specification requirement 5.1(iv). It was also thought desirable to arrange for unequal length and width dimensions such that a larger proportion of each briquette would suffer maximum compression at the nip point at any instant, thus keeping the rolling speed to a minimum.

#### Experimental Method

The single rectangular die cavity was filled with fresh straw in a similar manner to that described in the previous experiment and force was again applied from the Denison machine. A nominal briquette mass of 75 grammes was chosen to suit the capacity of the test equipment. Several briquettes were made to establish the approximate load which was required to consistently give a relaxed density of approximately  $500 \text{ kg/m}^3$ . The work done in compression was found by integration of the loading curves.

For these experiments the load was released immediately maximum pressure was reached.

## Observations

Despite the comparatively high pressures used in these experiments, the rectangular briquettes appeared to be slightly less stable than those formed in the cylindrical shaped die. The rectangular briquettes also looked rather less attractive than the cylindrical samples, there being more loose fibres around the edges and into the corners. Each charge had some individual straws which had remained unbonded to the surface and could be simply blown away. Only very small quality improvements were made by increasing the pressure level from 45 MN/m<sup>2</sup> to 62 MN/m<sup>2</sup> but at pressures below this range, the briquettes were thought to be of a markedly poorer quality. In all cases, the briquettes quickly relaxed to more than two and a half times their minimum compressed size when released.

## Results

TEST No.	MASS (g)	MAX. LOAD (kN)	MAXIMUM PRESSURE (MN/m <sup>2</sup> )	COMPRESSED DENSITY (kg/m <sup>3</sup> )	RELAXED DENSITY (kg/m <sup>3</sup> )	RELAX'N RATIO	WORK DONE (J)	SPECIFIC ENERGY (MJ/t)
1	75	162	45	1227	475	2.6	1542	20.6
2	79	162	45	1373	476	2.9	1644	20.8
3	72	180	50	1429	502	2.8	1422	19.7

Table 6.3.2a Closed Rectangular Die Test Results.

### 6.3.3. Shearing Experiment

Fig.6.3.3a shows, diagrammatically, the apparatus used to verify the principle of simultaneous compaction and shearing proposed for the continuous flow machine. The rig, which was an adaptation of the apparatus used in 6.3.2, comprised three adjacent rectangular cavities measuring 55mm X 65mm in cross section formed between two sets of solid steel punches. The three sets of dies were completely encased in a fabricated 12mm thick steel casing such that the bottom die-set was fixed in position but the top die-set was free to slide. The central rectangular cavity was arranged to be out of step with the outer dies by seven millimetres. The three punches were pressed simultaneously under the hydraulic press.

The apparatus was designed to be representative of a small section of a radial or conical disc compactor at the nip point. It was assumed that a gap of about 3 mm would be needed between the two rotating parts to avoid the possibility of mechanical contact. Tests were, therefore, undertaken to a fixed closure height.

#### Experimental Method

The stepped cavities were randomly loaded with a known mass of straw and load was applied to the punches until the package height was reduced to 10 mm. At this point the load was suddenly released. The straw packages were removed and the shearing effect was observed. The experiment was repeated for various masses of straw resulting in different density briquettes. The outer briquettes from each test were disregarded as only the central sample could be said to truly represent a briquette formed by a continuous process machine as only this one had two sheared edges.

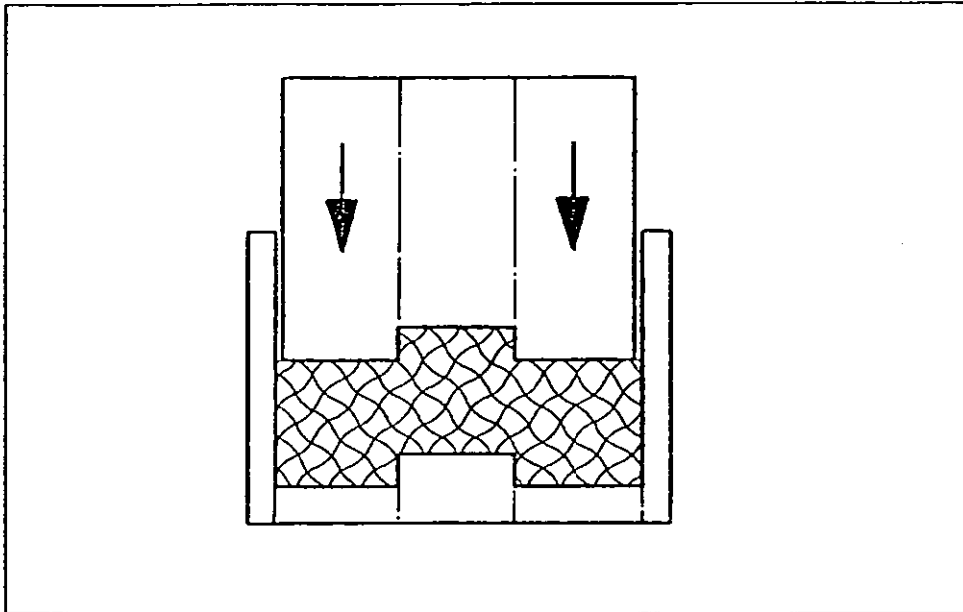

Figure 6.3.3a. Shear Test Rig.

#### Observations

There was a tendency for straw to be unevenly distributed across the length of the die resulting in an uneven pressure distribution. In all cases the centre briquettes were the heaviest which suggested that they had suffered a pressure greater than the average over the projected area and consequently, it would be reasonable to assume that their relaxed density was somewhat enhanced for any given load. Only a small improvement might be expected in extending the tests to higher

pressures, however the maximum load available from the Denison machine was 500 kN which is roughly equivalent to an average pressure of  $45 \text{ MN/m}^2$  across the three samples.

The centre briquettes formed in tests 1, 2 and 3 (table 6.3.3b) held together well but, although the straw sheared down to relatively low densities, the subjective quality of these light briquettes was much poorer and greater relaxation was observed. In all cases, the sheared edges of the briquettes appeared to be rather less well bound together than the two edges which had been contained by the sidewalls and consequently, the overall briquette stability was thought to be marginally poorer than in samples made under similar pressures in the closed die rig.

Results

TEST No.	CHARGE MASS (g)	BRIQ'T MASS (g)	MAXIMUM LOAD (kN)	COMPRESSED DENSITY (kg/m <sup>3</sup> )	RELAXED DENSITY (kg/m <sup>3</sup> )	RELAX'N RATIO	SHEARING CONDITION *
1	150	52	498	1445	530	2.7	1
2	145	54	418	1510	539	2.8	1
3	130	52	250	1455	501	2.9	2
4	119	44	176	1230	362	3.4	1
5	102	38	138	1063	295	3.6	1
6	89	32	93	895	235	3.8	3

\* Shearing Condition 1: Completely sheared through.  
Shearing Condition 2: Sheared through with the exception of one or two single straws but easily separated.  
Shearing Condition 3: Incomplete separation.

Table 6.3.3b Shear Test Results.

#### 6.3.4 Experimental Notes.

Some practical difficulties were encountered while conducting these tests which were to eventually lead to some changes in the experimental method and equipment during later laboratory work. The following notes might, therefore be useful to future researchers:-

It is very easy to underestimate the magnitude of the forces involved in this type of work. The simplest straw compression rig needs to be very sturdy in construction and hence tends to be heavy and inconvenient to handle.

Loose tolerances between the moving parts, aggravated by deflection of sidewalls under substantial loads, can cause straw to become entrapped between the plunger and the fixed chamber. Such traps not only make withdrawal of the plunger and ejection of the briquette difficult and time consuming but also add to the lack of conformity and generally poor integrity of the experimental data.

Loading the die consistently is very important and a rigorous procedure for this must be established. The rig must be filled in a single operation with a random straw supply. Straw must not be offered in discrete packages.

Experimental equipment must be designed to facilitate loading and rapid ejection.

Condition of supply and consistency under storage conditions of the straw used in the experiments has a marked effect upon the experimental results. Steps should be taken to maintain the uniformity of the raw material for any set of comparative results and the type



and condition of straw used should be stated.

### 6.3.5 Conclusions from the Experimental Evaluation

The compression curve for straw appears to follow an exponential law and compression can be conveniently considered to take place over two distinct regions: a primary compaction region of low pressure over a large displacement and a secondary compaction region of high pressure over small displacement.

Rectangular straw packages offer slightly poorer quality than cylindrical ones for any given pressure and a nominal pressure of around  $50 \text{ MN/m}^2$  will be needed to form consistently stable briquettes. Higher pressures than this do not produce proportionally higher package densities.

Briquettes will relax to around two and a half times their original formed size.

The specific energy needed to compact straw into briquettes is approximately 20 MJ/t. The power which would be required to produce briquettes at a rate of 10 t/hour is, therefore:

$$\frac{20 \times 10 \times 10^3}{3600} = 55 \text{ kW, plus machine losses.}$$

Straw can be made to shear into separate briquettes using stepped dies and it is not necessary for the two die halves to come into contact.

## 6.4 THE MULTISTAGE CONCEPT

The experimental evidence would suggest that the ideas described in section 6.2 could be used at the heart of a new design of field machine but, clearly, the complete device would need additional handling stages to lift and feed the straw to the compactor and to remove the finished briquettes at the end of the operation. The entire machine might, therefore, be conveniently divided into a number of discrete stages.

### 6.4.1 The Pick-up

Many agricultural machines collect crops directly from the swath. In particular, this is a requirement of all types of baler in use today and several designs of pick-up have been successfully employed for many years. The most common type uses a large rotating drum fitted with spring steel tines to collect the straw. The tines retract as the drum rotates releasing the straw onto a simple helical auger or screw conveyer. The loose straw is then conveyed to a collection point which may be at the centre or to one end of the conveyer. This arrangement is well proven and would provide an ideal pick-up for a field-briquetting machine.

According to WestMac Ltd.<sup>(39)</sup>, the power requirement for a typical forage harvester **pick-up** may be taken as a nominal 5 hp (3.7kW). This stage of the machine will, therefore, require no further explanation.

#### 6.4.2 The Pre-compactor

The evaluation experiments determined that the compression cycle for straw could be conveniently approximated to two distinct phases, so it would be useful to conceive machinery in sympathy with the different requirements of each phase.

A precompaction stage would take loose straw as supplied by the pick-up, then gather and compress it into a continuous 'rope' of density similar to that of a normal bale. At this density, the straw would not be expected to bind together (bales need to be tied) but would be restrained sideways by the compactor. This phase of the operation would involve lightly loaded mechanisms operating over fairly large displacements, requirements which are common to conventional agricultural engineering practices. The pre-compactor must give a reasonably homogeneous output, considerably reduced in bulk, which might be handled by the final stage compactor into which it would feed.

Four different concepts are considered for the design of this stage of the machine.

##### The Conical Auger

An adaptation of the screw conveyer to produce compression. Figure 6.4.2a describes a system where helical flutes are rotated within a conical casing. Upon close examination, this system was found to contain three basic flaws.

- (i) The compression is effectively generated by pushing straw down

the walls of a stationary outer cone. The friction coefficient of straw on the cone material is unknown but it would be reasonable to assume that the friction forces resisting motion would be considerable. The efficiency of such a system must, therefore, be questionable.

(ii) In order to prevent the straw continuing to rotate along with the helical screw. The design must provide for a considerable frictional resistance between the straw and the outer walls: a requirement which is contradictory to that above.

(iii) The specification of the briquetting machine indicated that it would be preferable that the swath is conveyed continuously through the machine and not separated into discrete packages until the last moment. The flights of a conical auger would inevitably separate the straw as it entered the machine as each flute would cut right through

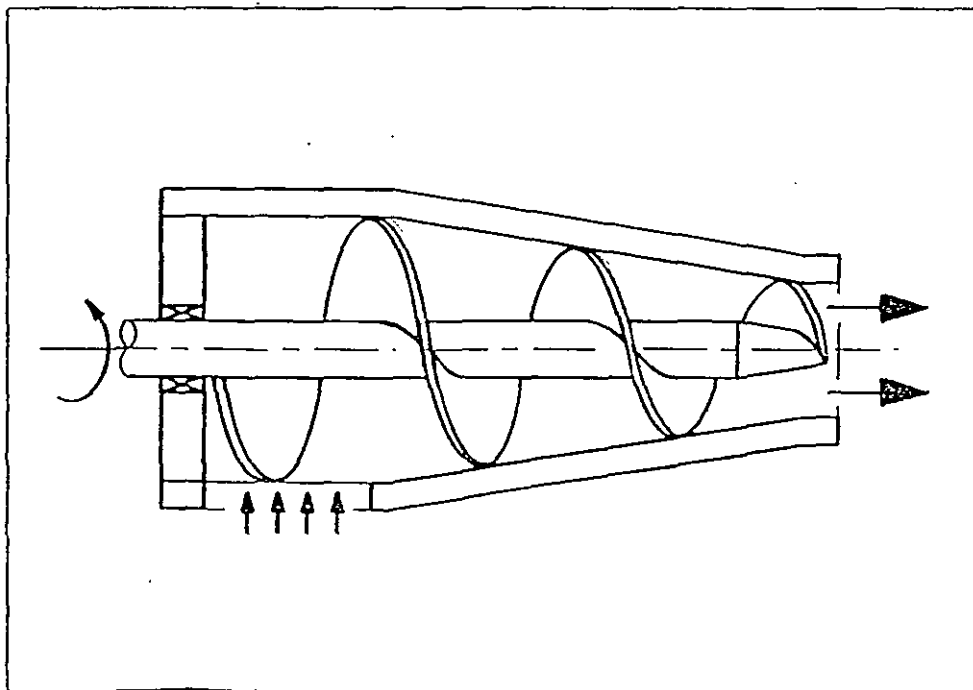

Figure 6.4.2a The Conical Auger.

the swath as it passed the entry port on each revolution. This unwanted cutting operation would not only consume additional power unnecessarily but, in addition, the laboratory tests suggested that it would reduce the final durability of the briquettes.

### Converging Belts

Figure 6.4.2b describes a pair of conveyers inclined at an acute angle to each other. Straw, fed into the wide opening, would be conveyed between the belts and would be compressed as the distance between the conveyers reduces. A second pair of belts or chains could be placed in a plane which is perpendicular to the first pair to operate along the same longitudinal axis. These secondary conveyers would provide additional compaction at right angles to the primary operation. If the mechanical problems involved with mounting the two sets of belts to operate simultaneously on the same section of straw could be overcome, there would be no need for any stationary outer plates to touch the moving swath and opposing frictional losses would be minimised. Alternatively the two compaction operations could be arranged to follow in line.

An attraction of this idea is that the straw could be expected to leave the pre-compactor in pretty much the same orientation as it entered because it would not be violently manipulated in any way. Each pair of conveyers would provide for gradual uni-directional size reduction.

The main problems associated with this conceptual solution would likely be mechanical complexity and selection of suitable, hard wearing conveyer materials.

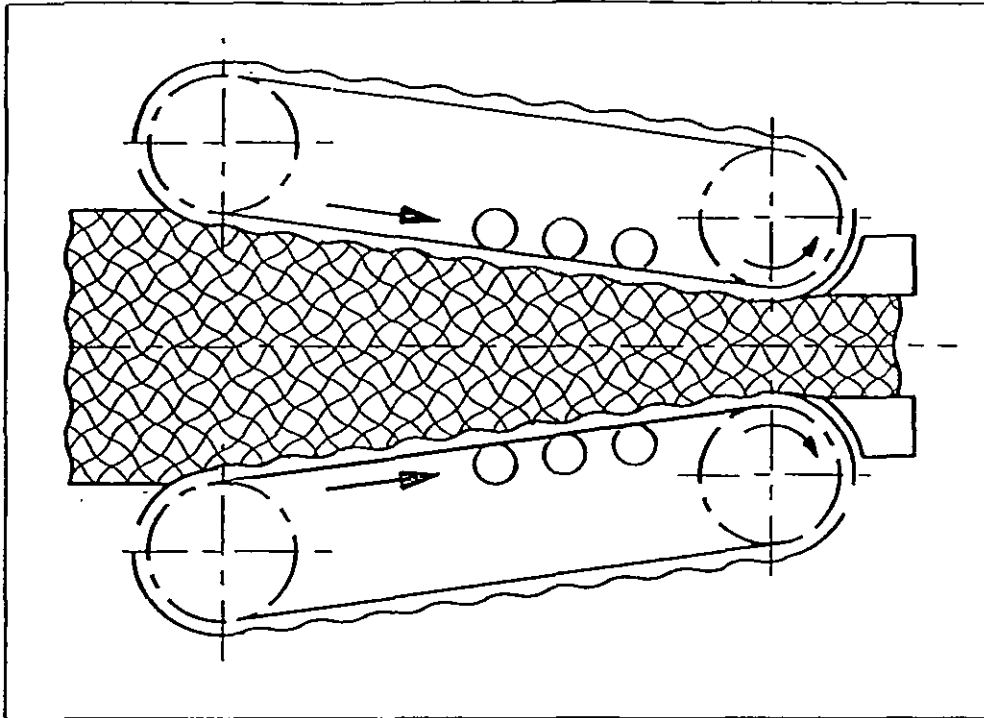

Figure 6.4.2b Converging belt Pre-compactor

### Straw Walkers

Figure 6.4.2c describes a pair of inclined conveyers with straw passing between them in a similar manner to that described above. In this case, however, the motion would be provided by reciprocating rails having rows of forward facing grips or teeth. Alternate rails are shown connected to cranks which would move them first inwards towards the straw and then forwards towards the nip point. At the end of each stroke the rails would be withdrawn and returned to the start position whilst the forward motion of the straw would be continued by an adjacent set of rails taking over and repeating the cycle.

This solution would appear to be even more mechanically complicated than the others. Such a machine would probably be limited in its maximum operating velocity by the inertia forces associated with the large reciprocating masses. It's mechanical complexity would suggest that reliability and longevity would be in doubt. An additional major drawback with this proposal is that the reciprocating teeth would cause substantial damage to many of the straw fibres as they passed through, so the product fed into the final stage would be markedly altered from the natural crop which lay in the field. It was unknown how this alteration would materially affect the quality of the final product.

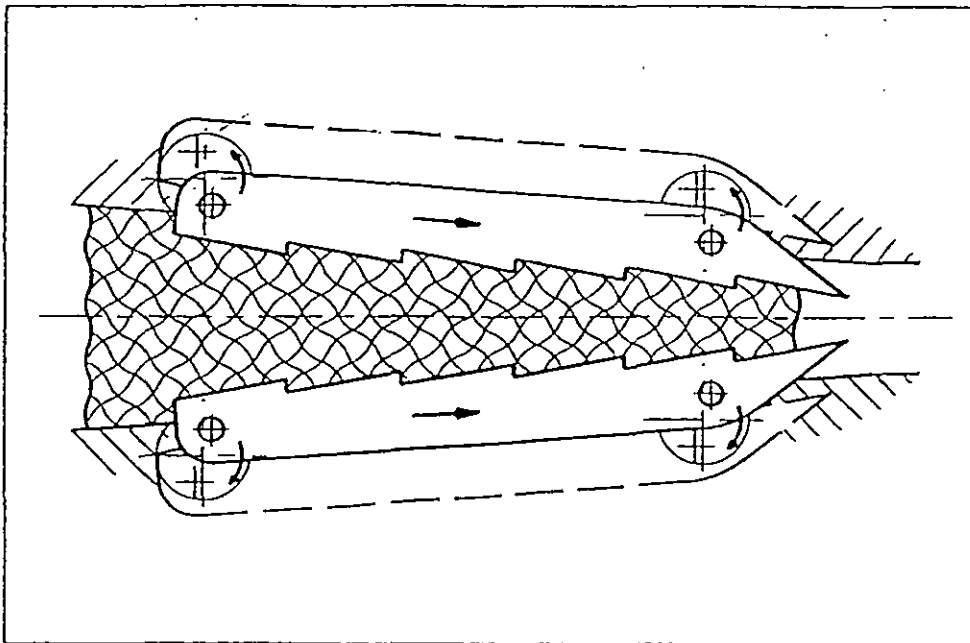

Figure 6.4.2c Straw Walker Pre-compactor

## Rollers

Perhaps the most obvious form of continuous compactor is the simple roller or mangle. The roller press is widely used for calendering many different materials and has much to commend it. It's main limitation is the relatively small reduction in section which could be achieved at each pass for any given diameter of roller. The depth which would automatically enter the rolls is a function of both the roller diameter and the frictional characteristics of the materials and is given by the expression  $\mu = \tan \alpha$  where  $\mu$  is the coefficient of friction between the straw and the rolls and  $\alpha$  is the angle described about the centre of the roll between the point of initial contact and the nip point. Clearly, with a fibrous material such as straw, the pass depth could be increased by adding teeth or tines to the rolls but these would also cause damage and orientation to the fibres and be wasteful in energy.

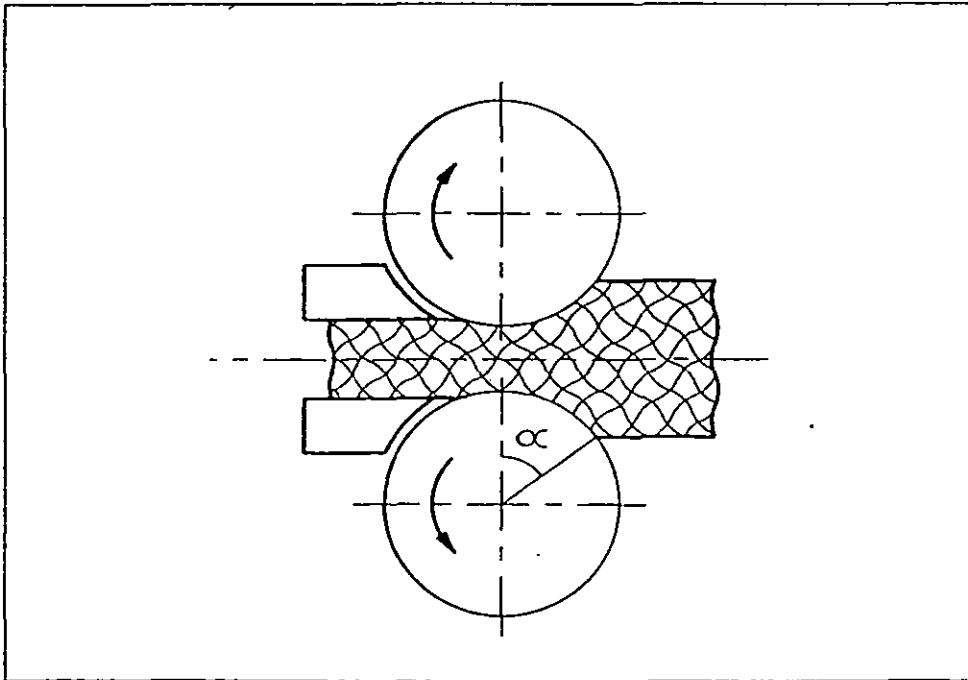

Figure 6.4.2d Roller Compactor



### 6.4.3 The Final Stage Compactor

At the heart of the machine would be a heavily rated continuous compactor employing one of the concepts described in section 6.2. This stage would need to operate over relatively small displacements at high pressures and should also separate the straw into individual briquettes. Finished briquettes would be ejected from the dies and fall onto the next stage of the machine.

### 6.4.4 The Output Stage

The last function of the machine would be to deliver the finished product into a suitable transport system. It is an essential requirement of the specification that a further handling operation would not be needed. Conveniently, high density briquettes could be conveyed and elevated by conventional means, so all that might be required here would be a moving conveyer positioned to catch the falling packages and lift them to an output chute. Suitable bulk transport in the form of a tipping trailer or truck would be drawn alongside or behind the briquetting machine to catch the fuel.

### 6.4.5 Additional features.

The stages described in the preceding clauses would form the basis of a complete briquetting machine for field use but it should be noted that such a machine would, in practice, be subjected to additional hostile parameters which would have a significant effect on performance. The most important of these foreseeable problems are those associated with swath density variations and damage caused by the entry of foreign bodies such as stones or metal objects. The best

solution to both of these problems might well be the addition of further intermediate stages to the machine which would perhaps modify the flow rate or check for and expel unwanted debris. It is, however, the opinion of the author that the mainstream activities associated with the fundamental design of the machine should be overcome before these features are considered in detail.

Only the more novel aspects of the machine have been considered in this synthesis. The finished agricultural machine would inevitably require considerable effort directed towards the detail design of the power transmission system and the rolling chassis, but this work is not included under the terms of reference of this thesis.

## 6.5 CONCLUSIONS OF THE SOLUTION SYNTHESIS

In the solution synthesis, the various stages of a field-briquetting machine are described and several alternative conceptual designs for both the primary and secondary compactor stages are examined. The experimental evaluation verified that the main performance parameters defined in the machine specification could be replicated in the laboratory and the preliminary results suggested that the ideas would be feasible. The process of forming briquettes was not, however, fully understood and it is clear that an improved understanding of the mechanics of compression of straw would be required if the machine design is to be optimised and high quality briquettes are to be made within the narrow margin of available input power. (See research data on briquette formation: Chapter 7).

### 6.5.1. Choice of Final Stage Compactor

The length of time which a briquette is held under load may be an important factor in promoting good adhesion of the straw and the 'converging slideway' solution would offer the only possibility of significantly increasing this time within the machine cycle. However, the author has shown, by experiment, that the concept of simultaneous compaction and separation would be workable and that stable briquettes can be made even when the load is not held, so the added complexity of the 'Converging slideways' concept could only be reconsidered if the quality requirements for durability and density of briquettes could not be achieved with the more straightforward designs. Contemporary published information does not describe the effect of time under compression on the formation of straw briquettes, (see Section 7.6).

The choice between 'Radial disc' and 'Conical Disc' compactor designs would be a difficult one as each has much to recommend it. However, the principle employed in both designs is very similar, so experimental research directed towards the adoption of one of these systems should be equally valid in respect of the other. A decision is not, therefore, absolutely necessary at this stage.

At the early stages of this project, the sponsoring company decided to push forward the parallel design of a prototype field-machine for commercial reasons. Development of this prototype, which was bound to be inhibited by the seasonal nature of the commodity, would be based upon the empirical findings of this project. At the time this decision was taken, the effect of rate of compaction of the straw was also a totally unknown factor and the reasonable assumption was made that a high formation speed would have a detrimental effect on briquette

quality. For this reason, the sponsoring company decided to apply for patent protection<sup>(40)</sup> for the considerably slower operating conical disc system and, therefore, the research effort has been primarily directed towards solving the problems associated with this type of final stage compactor. (See research data on rate of compaction in Chapter 10).

#### 6.5.2. Choice of Pre-compactor.

The synthesis examined four concepts for providing rapid, continual low density compaction and a suitable in-feed to the final stage. The analysis identified serious deficiencies in both the 'conical auger' and 'straw walker' systems. Of those remaining, the 'converging belt' concept suffers from complexity and the 'roller' type is severely restricted in its range of operation. Although the possibility of combining these two most promising ideas, acting upon the straw through perpendicular axes, may offer the ultimate solution, the research effort has been directed towards creating a better understanding of the less well documented converging belt system, (see Chapter 11 for research data on pre-compactor design).

The sponsoring company again applied for patent protection of the designs which it chose to adopt for the experimental field trial machine<sup>(41,42)</sup>. Since these initial patent applications, much work has been done to improve and develop the prototype machinery and the company who now owns the commercial rights to the technology recently resubmitted a single updated patent<sup>(43)</sup> to gain international protection.

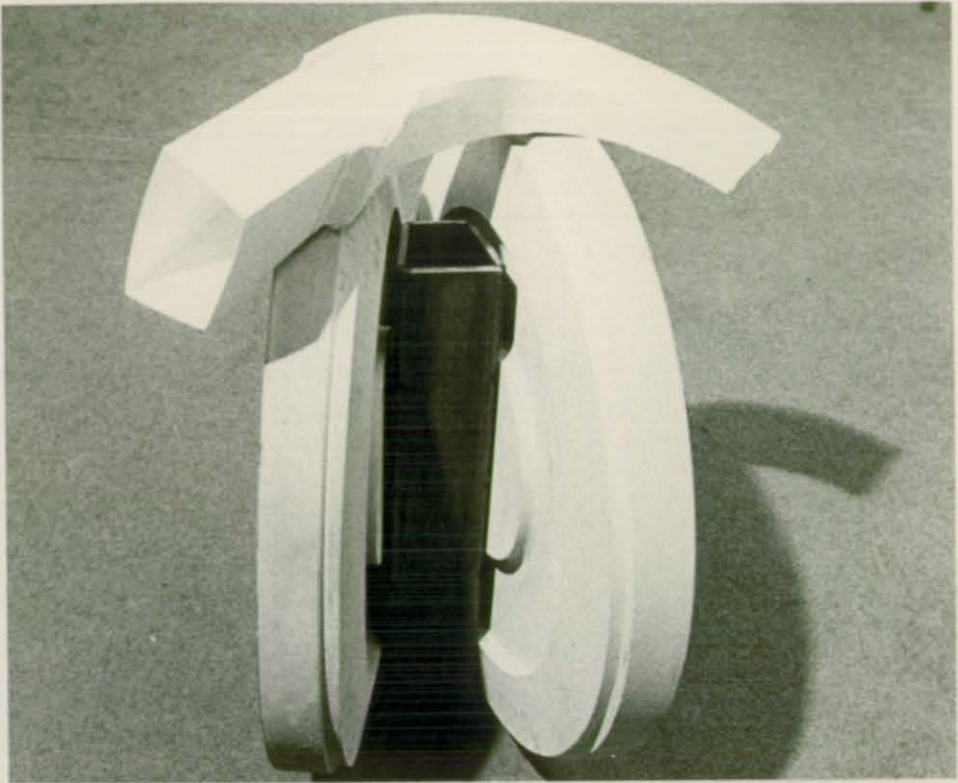

(a) Physical Models of the Conical Disc Compactor and Input Duct

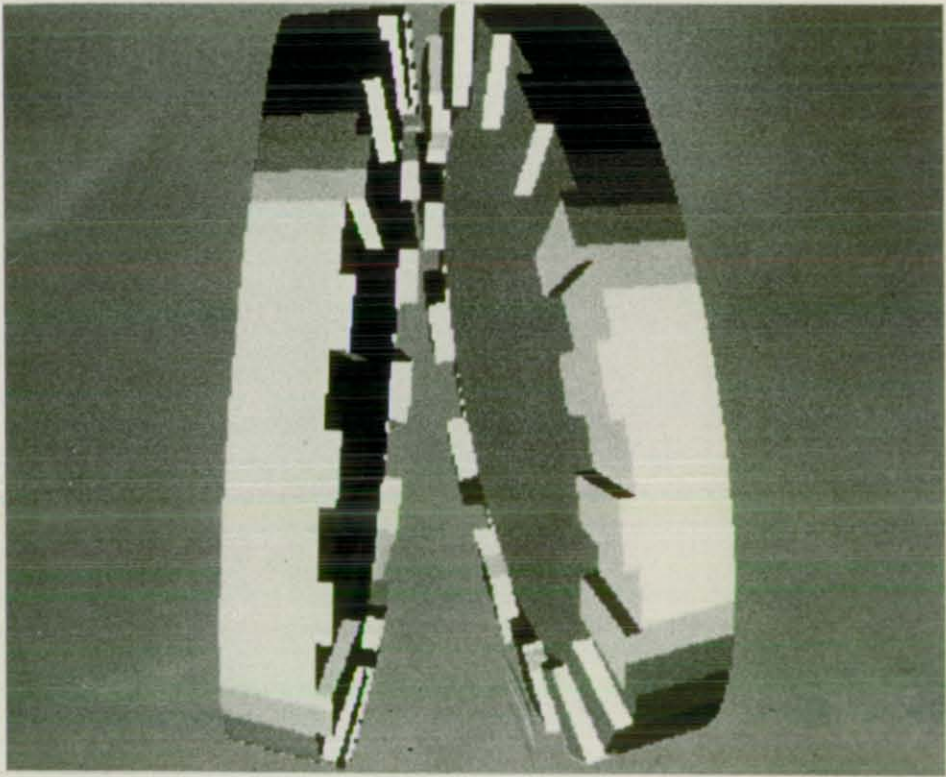

(b) Computer Generated Solid-Model of the Conical disc Compactor

## 7. BIOMECHANIC RESEARCH INTO BRIQUETTE FORMATION

The term, 'biomechanic' is used here to describe the association between the plant physiology and the mechanical behaviour of straw fibres under external loading. These two disciplines would normally be studied in isolation but have been brought together in this section of research in an attempt to gain a clearer understanding of the process of briquette formation.

It has been shown that a quantity of raw straw can be made into a durable briquette by the simple application of pressure in a closed die. The limits of acceptable moisture content, magnitude of the pressure and the durability of the final product are discussed at length in other sections of this thesis; however, the purpose of this chapter is to attempt to discover why the individual straws should bond or bind themselves together into a single fibrous mass. It follows that if the mechanism of bonding were better understood, then the machinery for performing the task could be more readily designed to give optimum results. Several experiments and investigations are described.

The raw material chosen for the primary investigation is baled wheat straw, simply because of its easy availability. Although the chemical composition differs between varieties, it is known that the straw of common cereals such as wheat, oats and barley share much the same physiological structure. All these cereals are the fruits of cultivated grasses which are members of the same family, "Gramineae". In previous studies, referred to in Chapter 4, it was shown that they all behave in a remarkably similar manner under compression and exhibit relaxation in similar proportion. It would be logical,

therefore, to assume that the basic mechanism of bonding is the same for all common types of straw. Where physiological differences between the cereal crops are known to exist, they are highlighted at the appropriate points in the text.

## 7.1 THE STRUCTURE OF STRAW

In order to understand what happens to straw under load, it is first necessary to gain some knowledge of the natural structure of the plant.

### 7.1.1 Visible Characteristics

(Additional material from References 44 and 45)

The almost endless number of varieties of wheat available today all originate from two or three wild species. The culms or straws are erect, elastic, cylindrical and in some wheats, more or less furrowed, with smooth, waxy surfaces. The upper parts in a young state are green; when ripe the colour in most wheats is a pale yellow. Mature straws of common bread wheats have five, six or seven nodes, usually six. At the nodes the stem is much contracted in diameter and always solid. The portions of straw between the nodes are called internodes. In most varieties of wheat the internodes are hollow, however in some continental variants the central part of the straw is completely filled with soft pith.

The whole length of the lower and much of the upper internodes are covered by leaf-sheaths which, in the living plant, function as protective and supporting structures to these sections of the straw, especially when the latter are immature. The length of individual

straws is dependent on the variety and on the external conditions in which it is grown. The individual internodes also vary in length dramatically. Normally on an individual stem the lowest internode is the shortest and the uppermost is the longest, with the lengths of the intermediate internodes gradually increasing.

The diameter of the straws is influenced by the same numerous factors as those which affect length. The average diameter of the separate internodes increases from below, up to the fifth; the sixth or upper internode is more slender than the rest. Each individual internode is thickest in the middle from where it tapers, more or less evenly to both ends.

Below, is a table of sample measurements of ear bearing straws from a typical wheat plant (grown in the East Midlands region of England). Wide variations from the figures given can however be expected.

<u>INTERNODE</u>	<u>AVE</u> <u>DIA (mm)</u>	<u>LENGTH(mm)</u>	
6th (Upper)	3.1	370	
5th	4.3	256	
4th	4.2	158	
3rd	4.0	98	
2nd	3.6	50	Wall thickness
1st	3.4	22	0.5 - 0.8 mm



At the top of the straw, after the ear has been removed by threshing, is the 'rachis' which is composed of very short nodes and internodes. In the case of oat straw, remnants of panicle (ear) are found instead.

The various components of straw have very different mechanical strength properties. The leaves are fragile and somewhat brittle when dry but the internodes are very tough and strong since they are built to carry the combined weight of the leaves and the grain. In briquette formation, therefore, it seems likely that much of the physical strength and durability would be derived from the internodes.

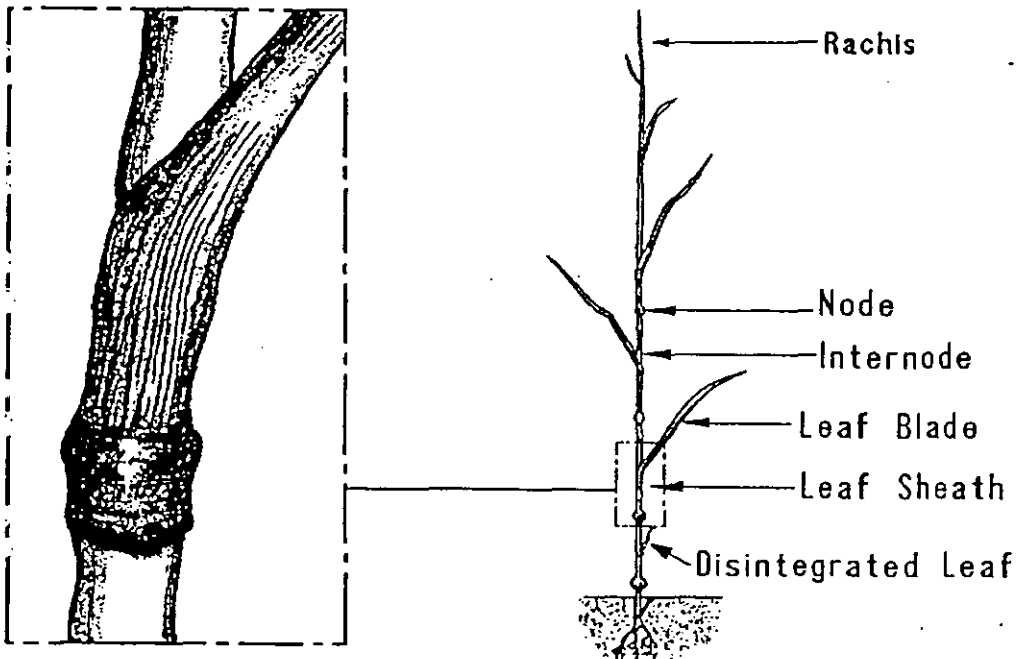

Figure 7.1.1a Botanical Components of the Wheat Plant.

### 7.1.2 Anatomy of the Culm (cereal or grass with the ear removed)

(Additional material from References 47 and 48).

Microscopic examination of several straw samples reveals physical details of the tubular section of the culm. The structure consists of the following distinctive components: the epidermis or exterior coating; the hypoderm or zone of mechanical tissue; clusters of green, leaf-like cells and a thick honeycomb layer of parenchyma containing distinctive vascular bundles. The accompanying sketches were prepared with the aid of a standard optical microscope (figures 7.1.2a, 7.1.2b and 7.1.2c).

The Epidermis, which is about 25-30 microns thick, is formed of narrow elongated cells 150-250 microns long with short square cells, 9-13 microns across, spanning between them at intervals. Some wheats are completely hairless on their outer surface but short coarse hairs can be seen on some varieties particularly those with a deeply furrowed surface. Rows of stomata, or pores, at spacings of about 200-250 microns can also be seen on the surface; these are effectively used as communication passages in the living plant (see figure 7.1.2b).

The parts of the stem not covered by the leaf sheath are encased in a hard cuticle, the surface of which has an extremely thin coating of wax.

The hypoderm is a strong elastic cylinder of mechanical tissue consisting of lignified (woody) cellular fibres with strong walls about 4 microns thick. In transverse section, the straw appears as a continuous zone of cells immediately inside the epidermis and varies in thickness but is generally of the order of 0.5mm. This layer,

which gives the plant much of its mechanical strength, is generally thickest at the base of the plant.

Parts of the stem contain a green leaf-like tissue consisting of delicate cells which, in longitudinal view, are irregular but almost circular in transverse section. The green tissue is embedded at intervals in the hypoderm but a portion of its surface is in immediate contact with the epidermis through the stomata by which it is brought into communication with the atmosphere. The tissue is only present in the upper parts of the stem and is readily distinguishable in old, 'dead' straw.

The colourless parenchyma extends from the hypoderm to the hollow central cavity. It is composed of thin walled cells polygonal in section and becoming shorter but wider as they near the centre of the plant. Towards the base of the plant the parenchyma cell walls become noticeably thicker and, in fact, give the plant some additional mechanical strength.

Amongst the complicated lattice of cells, which make up the wall of the straw, a transverse section reveals well defined clusters of cells called vascular bundles. The vascular bundles are, in fact, communication tubes which run up the length of the plant stem. They are, however, only of a passing interest here as they contribute little to the mechanical strength of the straw.

The accompanying photographs in Plate 7.1., taken through a scanning electron microscope, show a transverse section of straw through the internode and its surrounding leaf sheath at various levels of magnification.

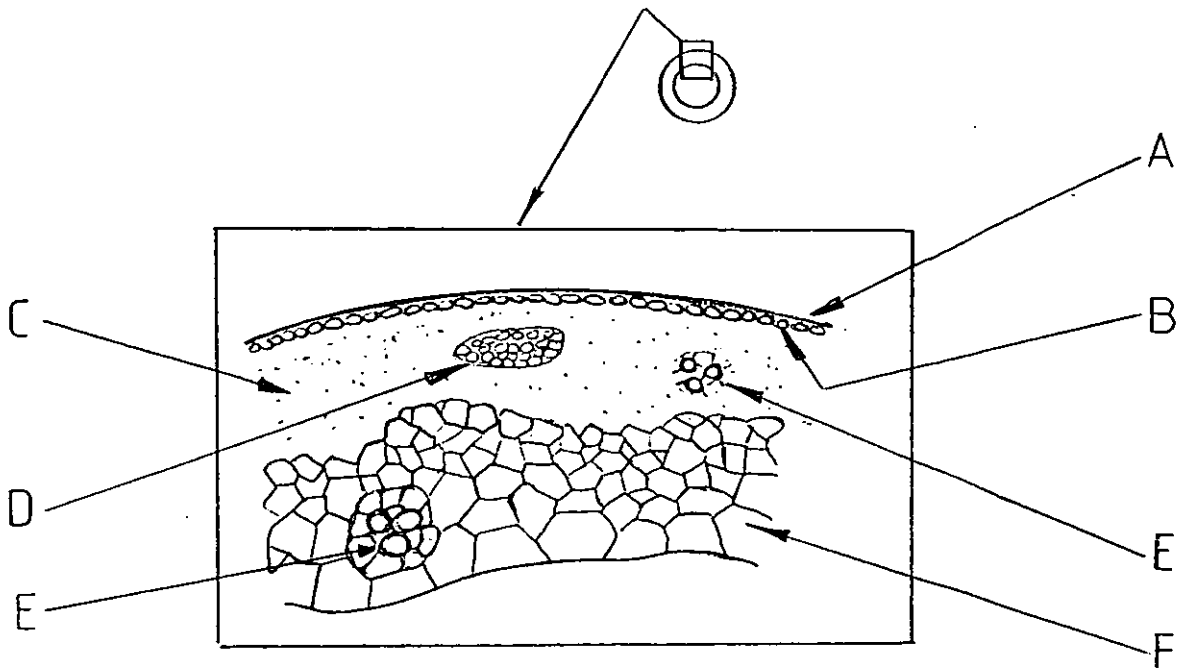

Transverse Section (simplified)

X100

KEY

A	Cuticle
B	Epidermis
C	Hypoderm
D	Green Tissue
E	Vascular Bundles
F	Colourless Parenchyma

Figure 7.1.2a The Wheat Plant (*Triticum Aestivum*)  
Transverse Section through the 3rd Internode.

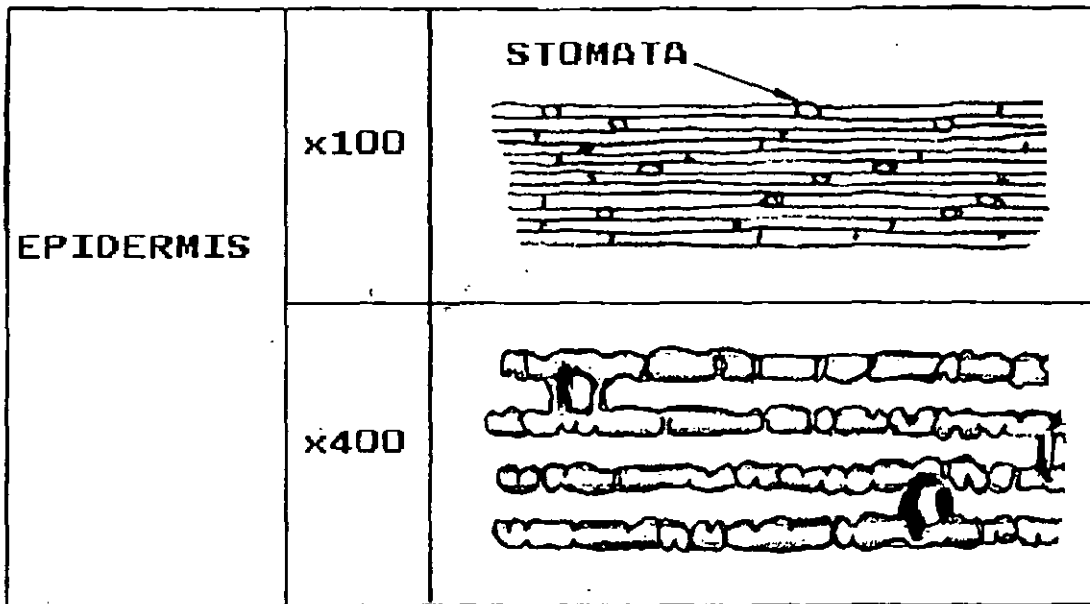

Figure 7.1.2b Microscopic views of the Outer Surface of Wheat Straw.

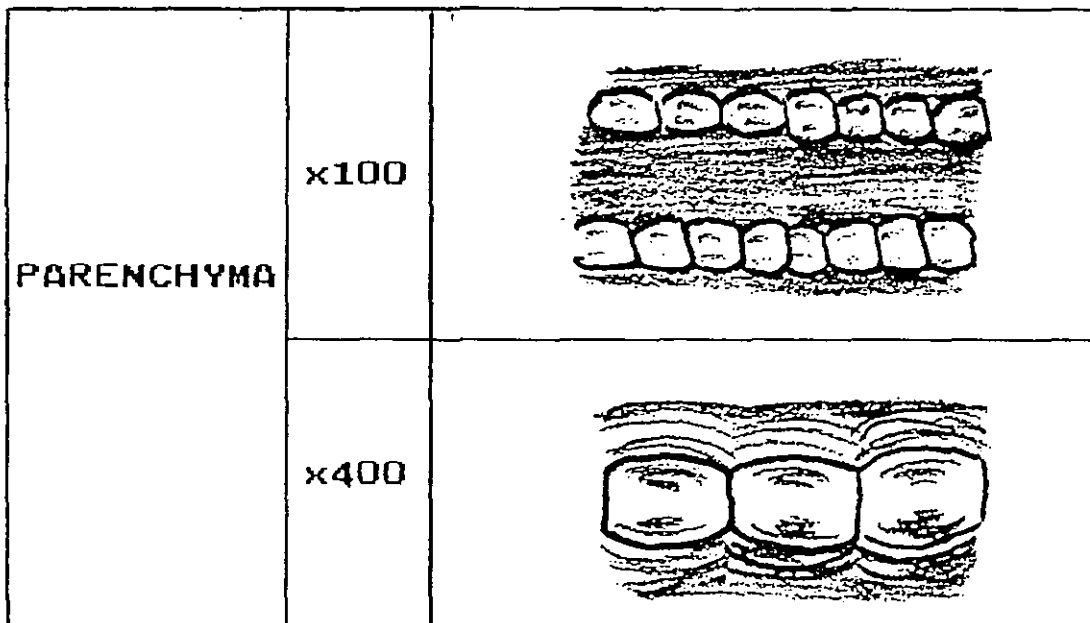

Figure 7.1.2c Microscopic views of the Inner Surface of Wheat Straw.

### 7.1.3 Chemical Composition

The absolute analysis of the chemical composition of cereal straw is very complicated. Fortunately, however, its constituents can be conveniently split into three principal groups of: celluloses, hemicelluloses and lignins. The lignins give the straw its structural strength and rigidity while the hemicellulose tends to bind the structure together. Straw also contains small quantities of proteins, waxes, sugars, salts and insoluble ash. The ash contains a proportion of silica which tends to blunt machinery and makes combustion difficult. The chemical analysis not only varies with species and variety but also across the different botanical components: the internodes, for example, have a high content of cellulose whilst the leaves have a higher content of ash, silica and protein. Yet further complication arises because the chemical composition changes appreciably according to the stage of maturity of the plant.

SPECIES	WHEAT			BARLEY		
	Internode %	Node %	Leaf %	Internode %	Node %	Leaf %
Crude Protein	2.9	4.5	4.8	1.7	4.0	3.7
Cellulose	41.1	32.7	32.3	43.3	33.2	36.4
Hemicellulose	24.5	28.6	25.6	24.2	33.1	28.3
Lignin	21.6	21.7	26.8	17.6	16.7	14.3
Ash	3.8	5.1	9.6	1.6	3.1	4.4
Silica	1.4	1.5	3.9	0.3	0.4	1.1

Table 7.1.3a Chemical Composition of Straw Components<sup>(46)</sup>.

## 7.2 THE EFFECT OF PRESSURE ON THE MICRO-STRUCTURE

There are essentially three modes by which the straw particles could gain their cohesion.

(i) By intermolecular forces caused by dipolar interaction (e.g. hydrogen bonds).

(ii) By the extraction and re-deposition of an adhesive substance which joins to the substrate and acts as an intermediary between layers.

(iii) By mechanical embedding of fibres or fibre particles.

Rehkugler and Buchele<sup>(49)</sup>, investigating forage grasses under compression, considered that the protein content of the grass was primarily responsible for bonding and stabilisation and suggested that one effect of the load was to squeeze the protein and pectins out of the stem and leaf walls and that this subsequently acted as a bonding agent. The protein content of the straw internode, at around 2 per cent, is about half that of the leaves and, in comparison with forage grasses the proportion of internode to leaves in straw is very high. In addition to this, the moisture content is inherently lower than that of grass because straw is essentially a dead, not a living, material. It would be expected, therefore, that this type of adhesion would play a much less significant part in the bonding of straw briquettes and this factor, alone, could account for much of the fundamental difficulty that previous researchers have experienced when adapting forage processing machinery to straw.

If protein adhesion was indeed a major factor in bonding straw briquettes, then it should be possible to squeeze the substance from individual straws by loading them and observe either internal bonding

of the cellular structure within the straw or detectable adhesion between adjacent straws. One would also expect to see evidence of a 'sticky' deposit upon straws taken away from a pre-formed wafer.

#### 7.2.1 Dissection and Visual Examination of Formed Briquettes

The following observations were made upon close examination of a number of laboratory samples. See also Plate 7.2(a).

Inserting a sharp probe confirmed that the outside surfaces of the briquette were harder than the centre. This was particularly noticeable at the corners of rectangular packages. Outside surfaces also had a more glazed appearance which was the result of burring from contact with the walls of the die. The hardness observed was the result of locally increased density.

The straw fibres were, for the most part, thoroughly interwoven and hard spots occurred where straw was severely creased, concertina like, in many directions.

The briquettes would break most easily in fairly well defined planes of weakness where few fibres laced the adjacent layers together. There was no evident inter-layer adhesion.

There were many longitudinal splits in the individual straws where the plant structure had fractured.

Some fibres on the outside of the briquettes were anchored at one end only; they could be lifted off the mass of the briquette with ease but were difficult to pull clear from the package when deeply embedded.



### 7.2.2 Microscopic Examination of Straw taken from Briquettes.

Individual straws were extracted from within briquettes and examined under an optical microscope. At high magnification the structure of the epidermis appeared to be intact with the distinctive long, narrow cells still plainly visible. Viewed from the inside, the open-celled parenchyma layer was completely destroyed and the prepared slides revealed only a grey blur. There was no evidence of any liquid smudges suggesting that protein 'juice' had been squeezed out of the tissue.

Of more interest here was the evidence revealed from examination of the creases and folds in individual straws. Naturally creases occurred in both the longitudinal and transverse directions; the simplest case being the flattening of the tubular straw section with longitudinal creases on the diameter. Figure 7.2.2a is a sketch of one such crease, viewed in transverse section at high magnification.

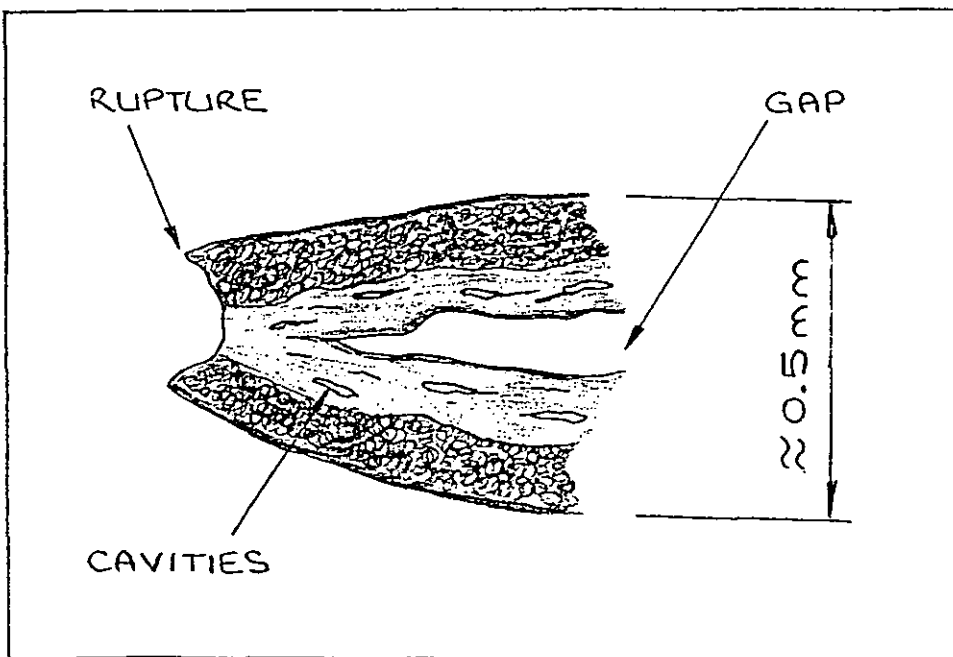

Figure 7.2.2a Crushed Straw, Transverse Section at the corner fold

Surprisingly perhaps, although completely crushed and much reduced in thickness, the two layers of parenchyma towards the centre of the tubular section did not appear to bond together at all and the two walls of the straw remained distinctly separate. At the extremities of several samples the epidermis was found to be completely ruptured. When folds occurred in the transverse direction, rupture of the outer layers happened less frequently and it is likely that this type of fracture would be largely dependent on the moisture level in the particular section of straw: too low and brittle fracture would occur, too high and a permanent crease would not form.

The electron-microscope photographs of crushed straw in plate 7.2(b-d) also show transverse sections at various magnifications. Note particularly:

- (b) the gap between the two walls of the flattened tube;
- (c) rupture of the epidermis at the crease;
- (d) spaces between the crushed cells. (dark area in top L.H. corner is the central gap between the tube walls).

### 7.2.3 Individual Straws under equivalent loads.

A special die-set was manufactured to allow individual or small groups of carefully aligned straws to be pressed with loads similar to those experienced by straws forming part of a briquette. (See Appendix V for details). The apparatus was used in conjunction with an hydraulic press and provided an even loading across a known cross-sectional area. Lateral movement between the hardened and polished upper and lower anvils the die surfaces was eliminated by the design so that the effect of pure compression would be observed.

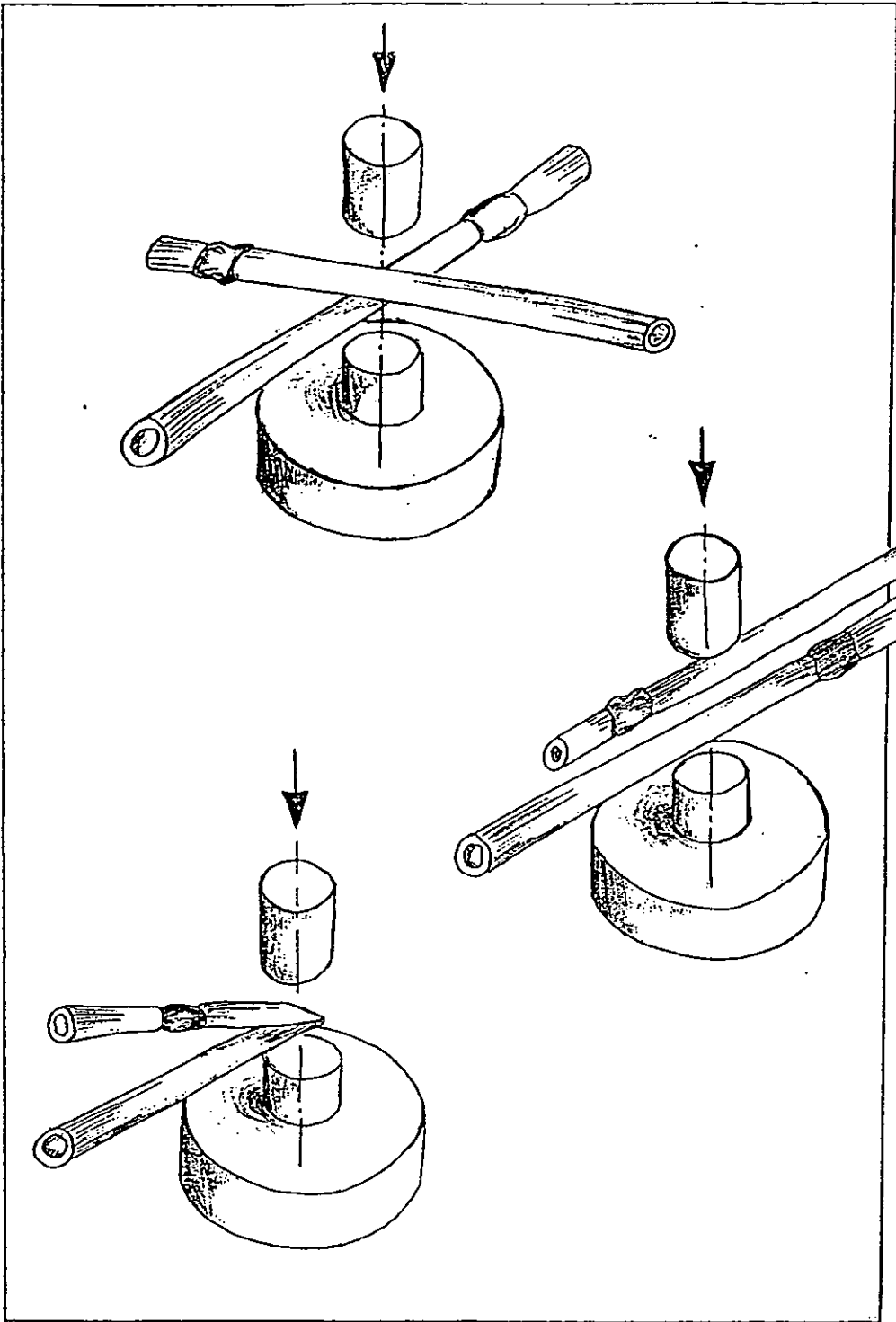

Figure 7.2.3a Testing Individual Straws

A number of microscope slides were made from individual straws which had been loaded in increments up to  $250 \text{ MN/m}^2$  but no additional information was obtained from these tests. Even at five times the nominal pressure there was little visible change in the cell structure of the outer straw layers and the softer central zones still failed to adhere.

In numerous other tests, pairs or groups of straws were placed between the anvils of the die-set and loaded. Some of the configurations are depicted in the sketches, figure 7.2.3a. In every case there was no perceptible adhesion by cross linking or hydrogen bonding between the individual straws, they could be simply blown apart after the test and the polished anvils remained clean. Only groups of straws pre-arranged to be interlaced were held firm by the permanent creases formed in the straws in much the same way that folded paper can be built into a sound structure.

### 7.3 THE EFFECT OF ORIENTATION ON BRIQUETTE FORMATION

As the foregoing tests had failed to detect any evidence of any kind of adhesive bonding, it was important that the theory of a simple mechanical interlace, compounded by pressure should be put to the test.

#### 7.3.1 Experimentation

To investigate the effect of varying the orientation of long straw fibres with respect to each other and to the direction of loading.

## Laboratory Procedure

Existing equipment from the preliminary experiments was used. A closed die rig consisting of a heavy die body, a two sided removable yoke (the other two sides of die were part of the die body) and a rectangular punch of 55mm x 65mm cross section. The compressive force was again supplied by the Denison testing machine and readings were taken from the built-in load cell.

## Experimental Method

Baled wheat straw was formed into briquettes in the closed rectangular die. For each sample the load was applied slowly to a maximum of 179kN (equivalent to  $50 \text{ MN/m}^2$ ) at which point it was suddenly released. The effects of varying the orientation of the straw fibres in the die on the stability and density of the product were observed and compared with a control sample made from random fibres. Arranging specific orientations was a tedious and time consuming operation, to avoid unnecessary repetition, the following schedule was adopted.

- (i) The die was filled with the straw fibres carefully orientated to lie vertically in the die, parallel to the line of action, such that they were forced to buckle under load.
- (ii) The die was filled with a similar mass of straw to (i) in a random manner for direct comparison.
- (iii) The die was filled with the straw fibres carefully orientated to lie horizontally across the die in approximately the same direction, perpendicular to the line of action of the punch thereby reducing the interlacing of straws to a minimum.
- (iv) The die was filled with a similar mass of straw to (iii) in a random manner for direct comparison.

It was not a practicable proposition to ensure that the same mass of straw was used in tests (i) and (iii).

**Random Fill:** The yoke was placed in the die block and the straw was rammed in through the top with hand pressure only. A known mass of straw was used. Care was taken to try to fill the die in a continuous swath as would be presented by a field machine, but the orientation of the individual strands was random.

**Layered Straw:** For both tests using non random straw, the yoke was first removed from the die block. Straw was layered with a specially-made coarse toothed comb, into an approximately straight bundle and fitted between the sides of the yoke in the desired orientation. When full, the surplus strands were trimmed off using a sharp knife. The yoke was replaced into the die block and the sample was compacted.

## Results

TEST No.	CONDITIONS	MASS (g)	APPLIED PRESSURE (MPa)	COMPRESSED HEIGHT (mm)	DENSITY (kg/m <sup>3</sup> )	RELAXED HEIGHT (mm)	DENSITY (kg/m <sup>3</sup> )	REMARKS
i	Vertical Orientation	53	51.7	11	1348	27	549	Durable Briquette
ii	Random Fill	53	50.1	12	1235	27	549	Durable Briquette
iii	Horizontal Orientation	63	50.1	15	1175	50	352	Unstable Package (No Side Force)
iv	Random Fill	63	50.1	13	1345	30	583	Durable Briquette

See Plate 7.3

## Notes

1. The briquettes were removed from the die as quickly as possible after compression. High side forces encountered in tests (i),(ii) and (iv) made removal difficult and this could take up to 5 minutes.
2. Relaxed measurements were taken after the briquettes had been unrestrained for several hours.

## Observations

Tests (i) and (ii) indicated little difference between a briquette formed from strands laying vertically in the die and one formed from the randomly filled control sample. Both tests produced dense and durable briquettes of approximately equal notional quality. This would suggest that in test (i), the individual straws buckled as the force was applied and the straws were forced to inter-link. Subsequent examination revealed that not all the straws buckled in a straightforward 'concertina' pattern but many split longitudinally and went on to settle at diverse attitudes. This movement suggests that a high degree of inter-weaving took place during the initial stages of compaction, while the package was still reasonably loosely structured.

In tests (i) and (ii) one would expect some degree of forced sideways migration of the straw fibres during compression and this would ensure that vacant cavities were minimal. The evidence supports this as dense briquettes were produced. Further, one would expect sideways movement to be greater in the vertically orientated sample because more straws would be forced to buckle. This supposition cannot, however, be substantiated by this experimental procedure as the difference in

density recorded was small and could easily fall within the bounds of experimental error for the test.

The package resulting from test (iii) could scarcely be called a briquette as it did not form into a single coherent mass. The result was simply a stack of flattened straws which could be individually lifted or broken apart in layers by the lightest handling. Again, there was no evidence of adhesion between fibres which would suggest that briquettes gain their stability from mechanical rather than molecular interlocks. The very small amount of durability which this package possessed could be attributed to inexact alignment of the strands making some degree of interweaving inevitable.

Of further interest from the results table is the evidence that straw, aligned in this way, occupies a larger volume than a random sample under the same pressure force. This could only be attributable to small vacant areas of the cavity remaining vacant throughout the compression cycle. Clearly, when pressed flat, straw is much less inclined to move within the die than when the fibres are randomly orientated.

The recovery of the sample with horizontal straws was also quite noticeably greater than that of the random samples.

Recovery rate for test (i)	=	2.45	:	1
Recovery rate for test (ii)	=	2.25	:	1
Recovery rate for test (iii)	=	3.33	:	1
Recovery rate for test (iv)	=	2.31	:	1

The most likely explanation of this phenomenon is that interwoven



strands mechanically resist the natural tendency of the material to resume its original shape suggesting that residual stresses must inherently be built into straw briquettes as they relax.

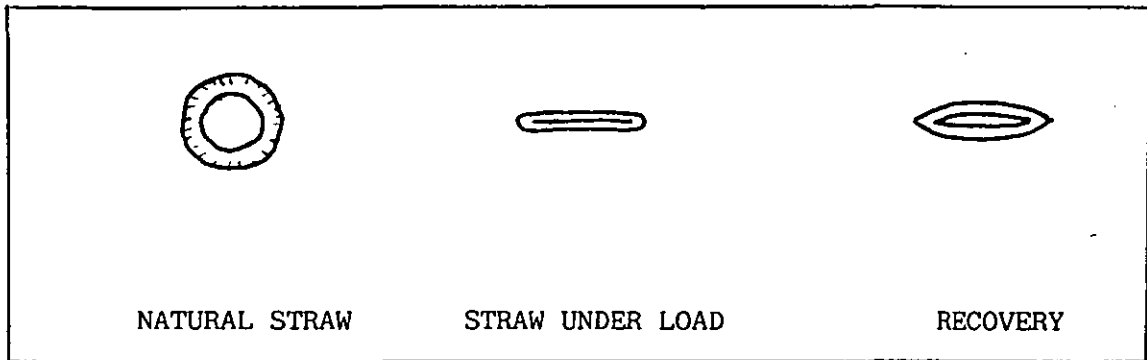

Figure 7.3.1a . Straw Cross Sections

Conclusions

The durability of a straw briquette formed by direct compression is dependent upon the initial orientation of the raw material. Greatest durability is obtained when the fibres are presented or forced to move into a highly interwoven structure. A lack of interwoven strands results in a total lack of adhesion and also allows for greater recovery of the package.

The sideways force on the die walls is largely a result of the buckling of vertical, or near vertical, straws and the presence of these straws makes for much greater movement of fibres within the package during the compression cycle. This migration ensures that vacant spaces are filled and results in more dense briquettes.

### 7.3.2 Implications for Field-Briquetting Machines

These experiments provide very strong evidence that orientation of the fibres in the direction of flow and perpendicular to the direction of loading (figure 7.3.2a) must be avoided. It is difficult to see how the fibres could possibly be arranged to lie perpendicular to the direction of flow (figure 7.3.2b) if continuous feed is to be maintained. This would, in any case place a finite limit on the length of individual straws which could be accommodated and offers little, if any, practical advantage. The most satisfactory solution would be that the swath should be presented to the compactor in a random manner created and maintained by an intermediate stage in the machine. It is possible that a bespoke device for mixing and disorienting the straw may be required in order to combat the natural tendency of conveying devices to organise in the direction of lay.

As a consequence of random orientation, however, significant side forces must be expected on the walls of the dies and, therefore, suitable die dimensions and materials must be chosen to withstand these forces. An extractor mechanism capable of overcoming the implied frictional loads must also be supplied.

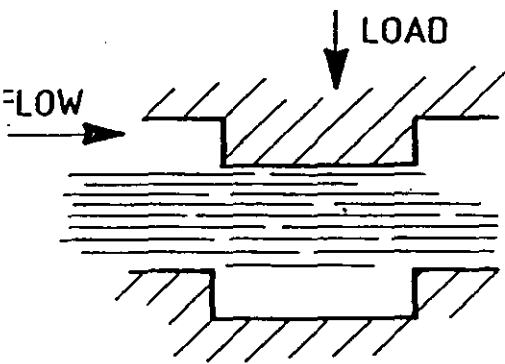

Figure 7.3.2a

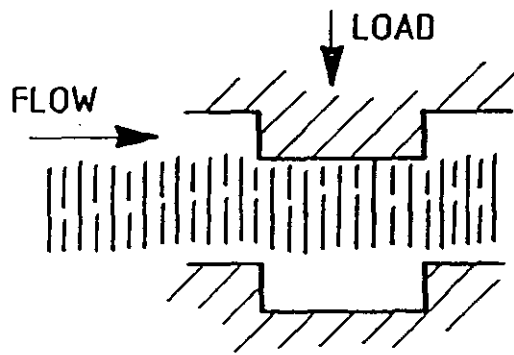

Figure 7.3.2b

## 7.4 EXPERIMENTAL ANALYSIS BY SEPARATION

### 7.4.1 Mass Distribution of the Botanical Components

Representative samples of fresh wheat, oat and barley straw were manually separated into their botanical components to determine the relative proportion by weight of each tissue type. Around half the mass of each sample was found to consist of internode and about one third was leaf tissue which includes both the blade and the sheath. The remaining mass was split approximately equally between the hard nodes and the remnants of the ear. It was impossible to subdivide accurately the tiny nodes and internodes which make up the rachis and, in any case, there was some chaff and a little grain present. The ear structure is quite different according to the species so the "ear remnants" for each cereal were treated as a single collective, (figure 7.4.1a).

### 7.4.2 Briquettes formed from the Separated Components

#### Objectives

To examine the ability of individual parts of straw to form into coherent briquettes and to determine the extent to which each component is responsible for bonding the whole-straw package. To determine the mode of adhesion of the fibres.

#### Laboratory Procedure

In order to accommodate the relatively small bulk of some of the separated botanical components a small compaction chamber was needed. The apparatus used was a closed cylinder and round plunger similar to

BARLEY STRAW  
Sample Size 37.7g

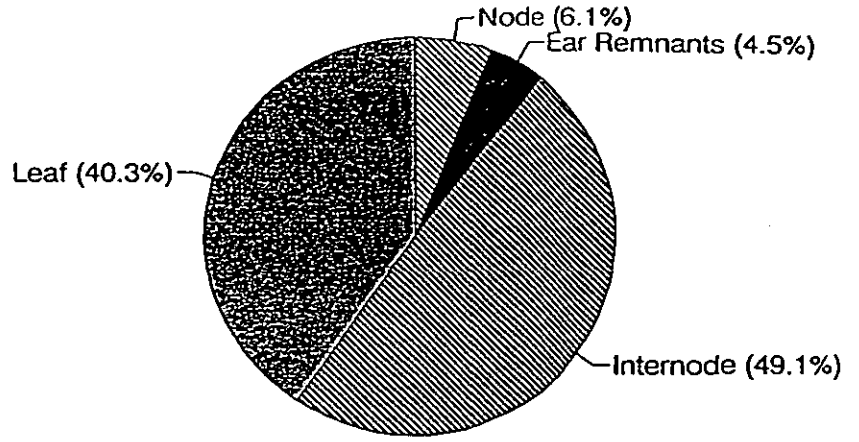

WHEAT STRAW  
Sample Size 34.9g

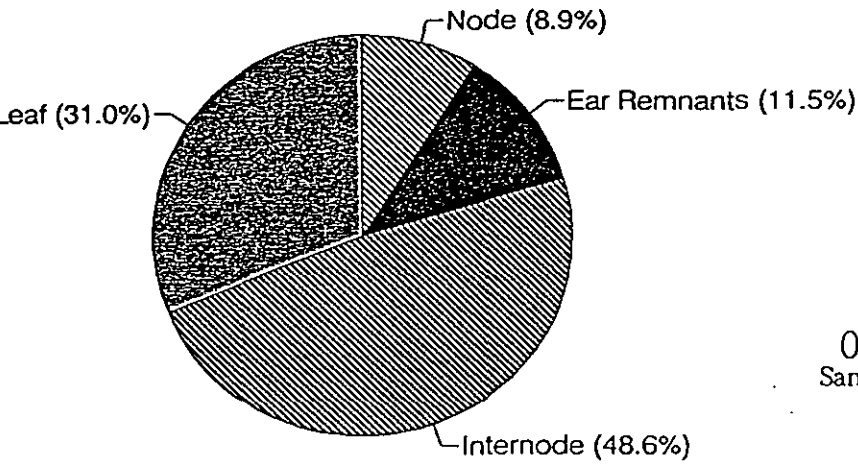

OAT STRAW  
Sample Size 38.6g

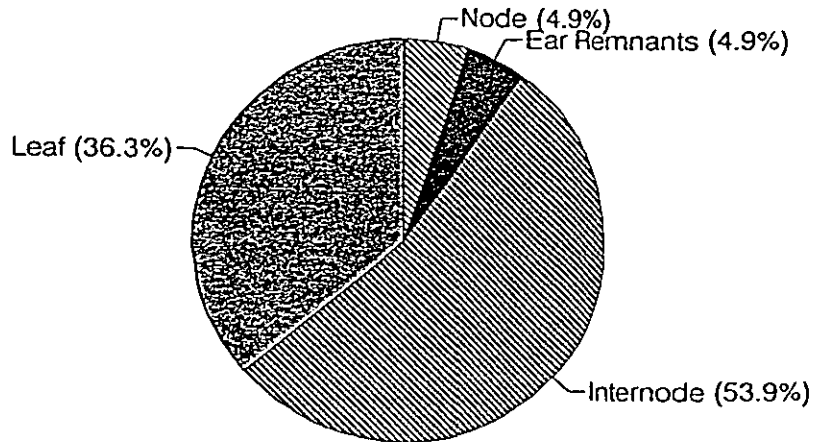

Figure 7.4.1a Mass Distribution of Botanical Components for Various Species.

that used in 6.3.1 but with a smaller, 25 mm diameter. Each sample was loaded to  $50 \text{ MN/m}^2$  with the Denison press at which point the pressure was suddenly released. Each sample was manually extracted from the rig as quickly as possible, weighed and carefully labelled. Measurements were taken at approximately 3 minutes after release and from these, the unit density of the relaxed package could be calculated. A photographic record of each sample was also made. (see examples in Plates 7.4 and 7.5).

For each species, two control samples of whole-straw were manufactured as direct comparisons.

### Results

The leaves of all the plants performed consistently well producing dense briquettes of around  $700 \text{ kg/m}^3$ . The main constituent, internode, was more sensitive to species with the dark coloured oat straw giving the best result and barley the worst. Although the ear remnants were quite different in composition they all gave similar wafer densities of around  $650 \text{ kg/m}^3$ . In each case; the separated nodes failed to form coherent packages under load, they crushed together initially but did not form a lasting bond and fell apart when removed from the die. For this reason, nodes are not included on figure 7.4.2a which gives a illustrated breakdown of the results.

Rather surprisingly, with wheat, the three major components produced individually more dense briquettes than the whole straw used in the control samples. In the other cases, the density of the whole straw sample, ( $\rho$ ) was almost equal to the summation of the component densities, ( $\rho_c$ ) multiplied by their mass proportions, ( $m_c$ ).

$$\rho = \sum \rho_c m_c$$

The variation across the samples suggests that either some experimental inconsistency was present or that the components of wheat interact in a somewhat different to the other plants. The most likely explanation for the latter would be due to the particularly large wheat nodes inhibiting the intermingling of the long fibres during the compression stroke. Nodes being hard and relatively resistant to crushing in comparison with other components.

### Observations

The relatively soft, light texture of the dry leaf tissues would not immediately suggest that strong mechanical bonds were responsible for the density and apparent durability of the leaf briquettes and the presence of potentially glutinous constituents like fragments of grain would indicate that another mechanism may be responsible for the constantly high bond strength of the ear remnants samples.

Subsequent dissection of the wafers indicated that both these presumptions were, in fact, substantially incorrect. Careful examination with a medical scalpel revealed:

- (i) Internally crushed leaf blades were found to become detached from the straw below if they were cut transversely at two points a short distance apart, there being no inter-layer adhesion, (figure 7.4.2b).
- (ii) The supposed viscid particles within the ear remnants remained, for the most part whole and not crushed by the operation and could not, therefore, have made a major contribution to the inter-layer adhesion.

Another important observation from this series of tests was the manner in which the various components resisted the gradual application of the load. Although pressure was applied at the same rate for each test the loading curve took a very different form for each botanical component. This is illustrated in figure 7.4.2c and was the result of the completely different elastic properties of the fibres. The compaction characteristics of whole straw will presumably be a function of the summation of the components so clearly the shape of the loading curve (and hence the power consumed) will vary with the proportion of each constituent.

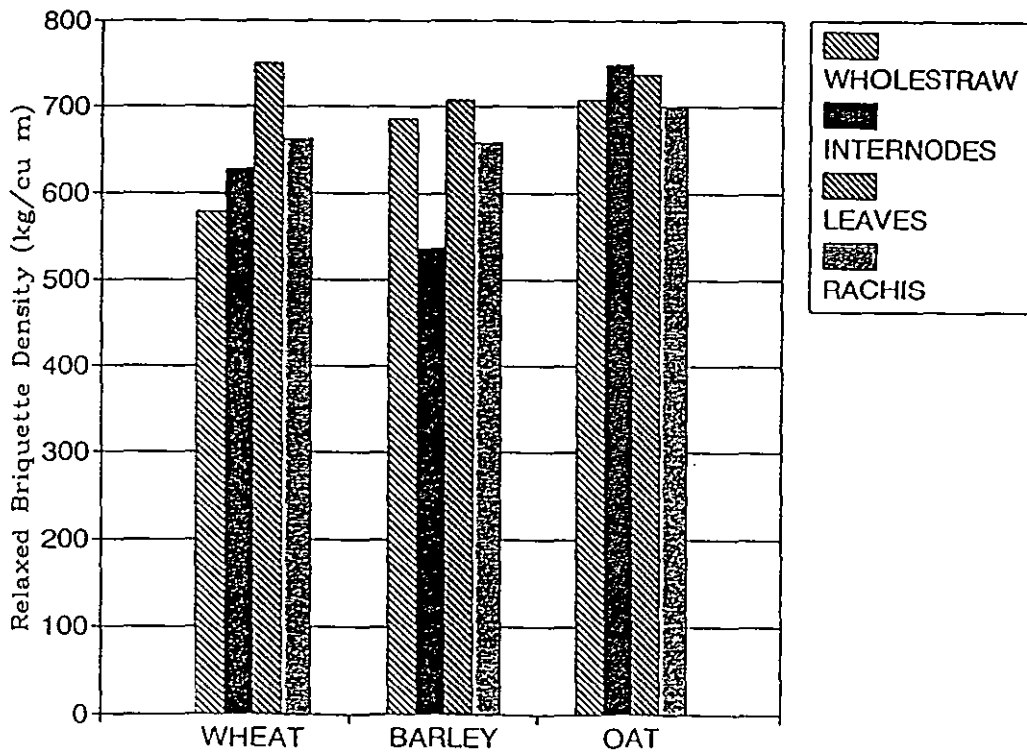

Figure 7.4.2a The Density of Briquettes formed from Individual Components (after 3 minutes Relaxation).

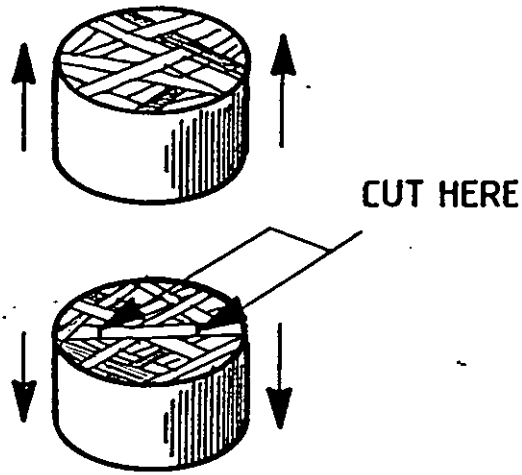

Figure 7.4.2b Checking for Adhesive Bonding by Dissection.

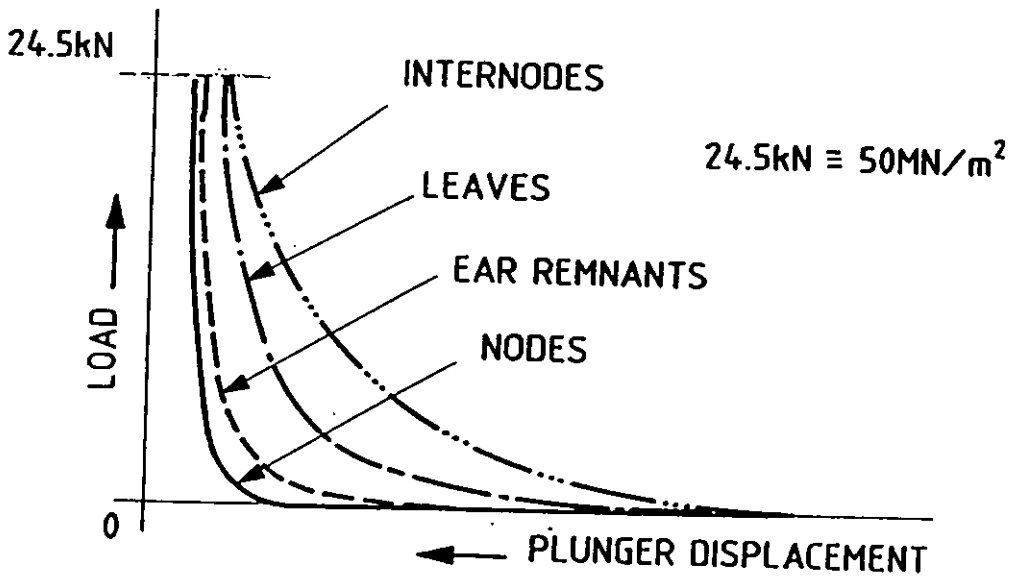

Figure 7.4.2c Illustration of the Loading Curves for the Botanical Components.



## Conclusions

The evidence again points to mechanical interlocking and bonding of the fibres being the predominant operator responsible for briquette formation. The differences in density would be most easily accounted for by the dramatic variations in elastic strength of the fibres giving rise to different degrees of shape restoration or relaxation.

### 7.4.3 The Effect of Chopping the Straw.

#### Objective

To observe the effect of reducing mechanical interlocks by chopping the raw material.

#### Laboratory Procedure

Whole wheat Straw and samples of separated leaves and internodes (the major constituents) were chopped in a domestic food processor and then formed into cylindrical briquettes as in clause 7.4.2. The pressure used was again  $50 \text{ MN/m}^2$ . Two chop lengths, 25mm and 5mm, were achieved by varying the time in the processor and the straw was categorised by the average length of the fibres. Each test was repeated twice to reduce experimental error.

#### Results

It was not possible to tabulate meaningful data on briquette density from this series of tests because the durability of the samples produced was, in every case, very poor. Instead, the following trends were recorded.

1. All samples pressed from chopped straw emerged in more than one piece and broke down further when handled.
2. The experiments generated many loose particles (fines) in addition to the main briquette fragments.
3. Finely chopped straw produced more disintegration and larger quantities of fines than the coarse chop length.
4. There was no detectable difference in stability between equivalent samples made from leaf and internode.
5. The density of the cohesive segments was quite variable but notably about 10% to 20% lower for the fine chop than for the coarse. The relaxed (3 minutes) density of 5mm chop whole straw wafer fragments was never more than  $500 \text{ kg/m}^3$ .

#### Observations

If the straw fibres were reduced in length, then it would follow that they would move more easily within the cavity and give a more homogeneous density distribution. Further, because of the non-linear loading characteristics of straw, it would be reasonable to assume that a more even distribution would result in a higher overall density under load. In particular, unless the bonding and relaxation characteristics of the material were altered by the chop length, a greater relaxed density would also be expected.

If the fibre bonds were produced by adhesive or molecular links then vigorous chopping would release and distribute adhesive materials

within the structure as an additional benefit to the process. On the other hand, if the durability of briquettes was derived from interlinked fibres or mechanical bonds, then many of these links would be destroyed by chopping and the durability of briquettes would be reduced.

### Conclusions

Both durability and relaxed density are reduced by chopping the straw.

Briquettes are held together by mechanical bonds and chopping the fibres prevents the bonds from being formed.

### Additional discussion

Chopping will give a reduction in the initial bulk of the material inferring a shorter compression stroke and reduced power input. However, the chopping process itself would consume a considerable amount of energy (estimated at between 10kW for light chopping up to almost 25kW for grinding at the proposed production rate). There is likely to be an overall energy penalty.

It is well known that briquettes made in static extrusion plants use chopped and ground straw to make extremely dense and stable packages. The conditions for producing these are, however, quite different with much higher pressures, elevated temperatures and extended cooling periods held under pressure. The mechanism of bonding in these briquettes is likely to be quite different and would provide material for a extensive additional field of study. Smith<sup>(15)</sup> investigated the effect of raised temperatures on whole straw briquettes made in closed

dies and found improvements in density and reductions in relaxation in samples formed in heated dies.

#### 7.4.4 Time Dependency

The importance of material structure variations on elastic relaxation has already been highlighted. It was evident that the density of the relaxed product would be, in some way, time related. This realisation prompted a second look at the briquettes described in clause 7.4.2.

After dry storage for approximately 3-months the samples were again weighed and measured. There was very little change in mass indicating no appreciable moisture loss due to evaporation but in each case, the dimensions had increased substantially. The results are given in figure 7.4.4a.

The internode is the toughest, most elastic of the fibre constituents and, predictably, internode briquettes showed the greatest additional relaxation, a massive 40% in the case of oat straw.

Measurements taken after an additional three months in storage detected no further growth indicating that stabilisation had been reached.

### WHEAT STRAW Cylindrical Briquettes

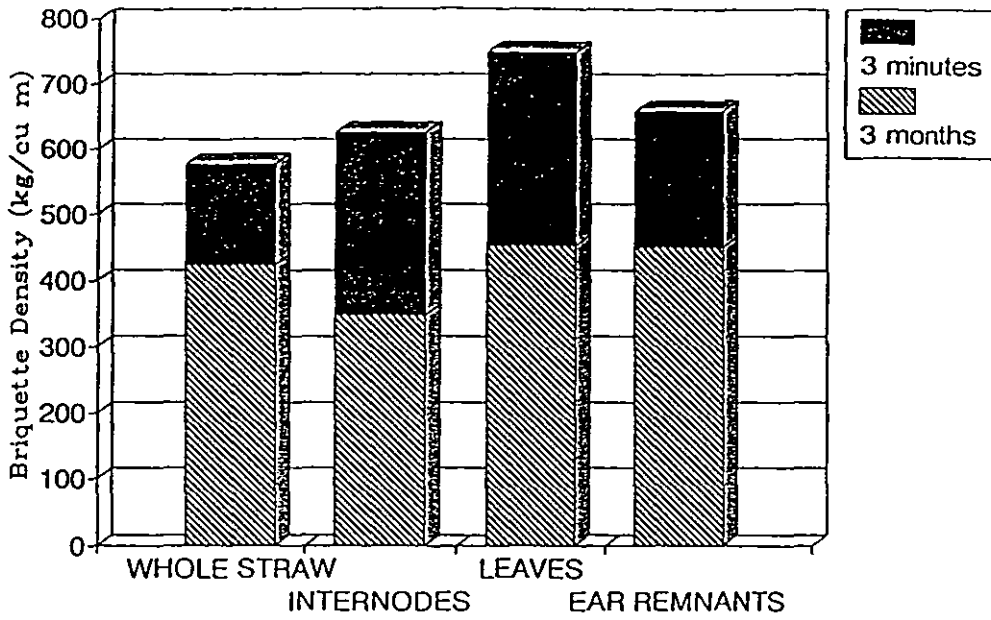

### BARLEY STRAW Cylindrical Briquettes

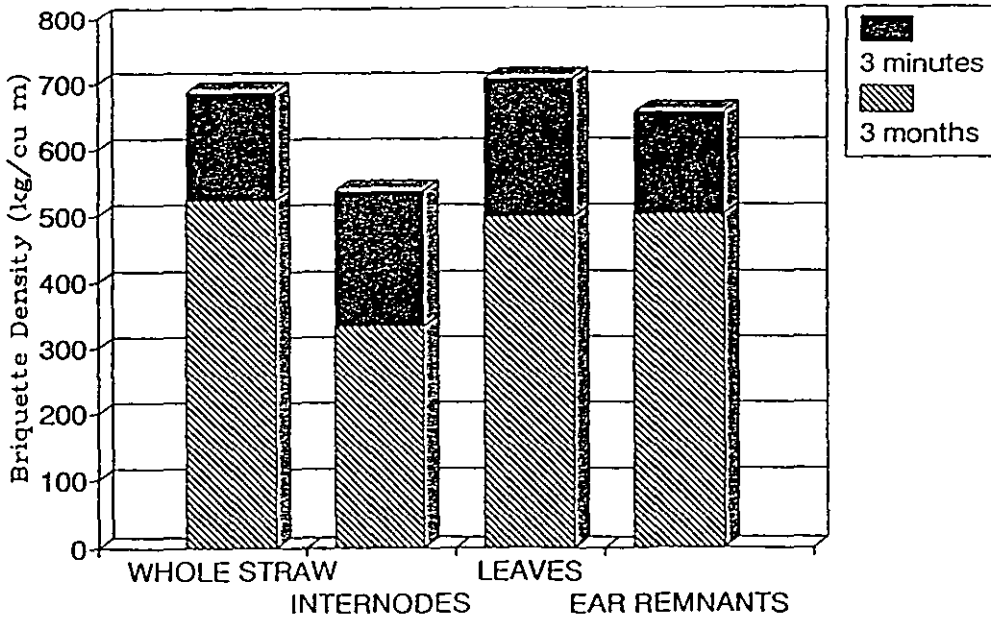

Figure 7.4.4a Relaxation of Samples (continued overleaf)

## OAT STRAW Cylindrical Briquettes

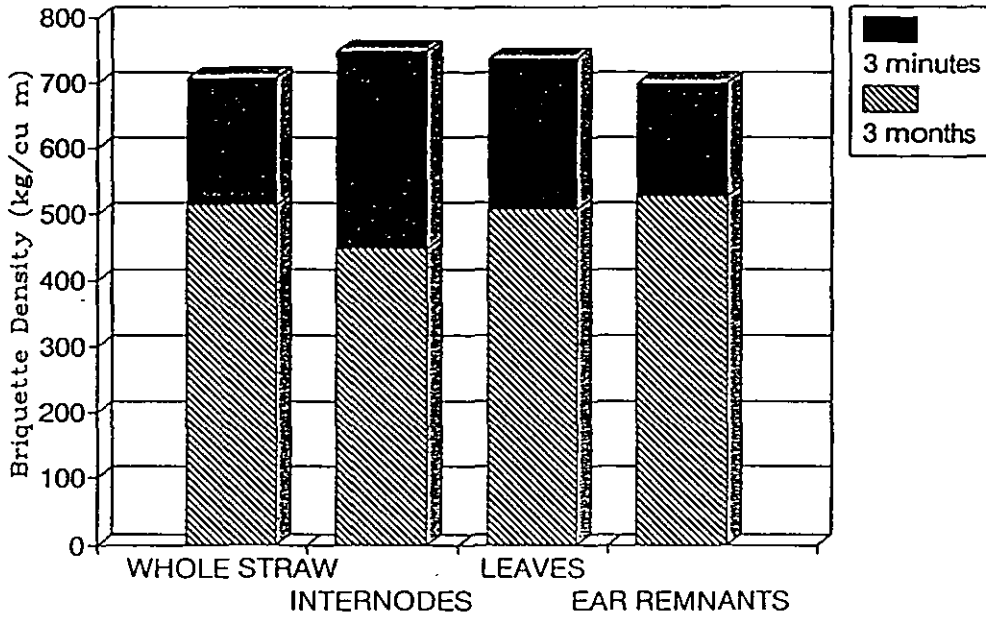

Figure 7.4.4a Relaxation of Samples (continued)

### 7.5 THE RELATIONSHIP BETWEEN PRESSURE AND COMPRESSED DENSITY

In their authoritative research document, O'Dogherty and Wheeler<sup>(35)</sup> proposed that the relationship between pressure (P) and density ( $\rho$ ) of barley straw radically altered at  $400 \text{ kg/m}^3$ . Up to this figure they proposed a simple power law of the form:

$$P = K_1 \rho^2 \quad (\text{Giving } K_1 = 0.0000112)$$

whilst at greater densities they suggested the relationship became logarithmic in the form:

$$\log_n P = K_2 (\log_n \rho)^4 - K_3$$

(Giving  $K_2 = 0.00226$  and  $K_3 = 2.32$ )

Note; Density is measured with the straw in its natural (wet) state.

There appears to be no physical or botanical reason why the behaviour of the straw should change at around  $400 \text{ kg/m}^3$  so it would seem questionable that two very different natural laws should be obeyed.

Alternatively, and with the advantage of computer based non-linear curve fitting regression routines, the author has found excellent correlation throughout the density range under consideration (from  $100 \text{ kg/m}^3$  to about  $1800 \text{ kg/m}^3$ ) using a modified power law, thus:

$$P = a \left( \frac{1}{\rho} - \frac{1}{\rho_0} \right)^{-b}$$

a and b are constants for any data set and their value is determined by multiplicity of interdependent experimental factors such as: material, condition (moisture, temperature, age etc.), die shape and size, charge mass, rate of loading and orientation.

$\rho_0$  represents to the 'closed' density of the material which is the maximum density /pressure to which this relationship applies.

The concept of 'closed density' is thought to be analogous to the characteristics of a helical coil spring (figure 7.5.0a) where, with the coils active the spring gives a linear resistance due to torsion in the coils but at a predetermined load, the coils make contact with

each other and all the load is then transmitted by direct compression. The characteristics at high loads are consequently quite different. When density  $\rho_0$  is reached, the straw fibres have ceased to move within the briquette and all the natural spaces within the cells (in the load direction) have been occupied.

The 'best fit' curves indicate that the 'closed density' for most straws is in the region 1800 - 2000 kg/m<sup>3</sup>.

Insufficient tests have been carried out to quantify the relationship of density to pressure above this range though this is, in any case, beyond the specified operating pressure of a field machine.

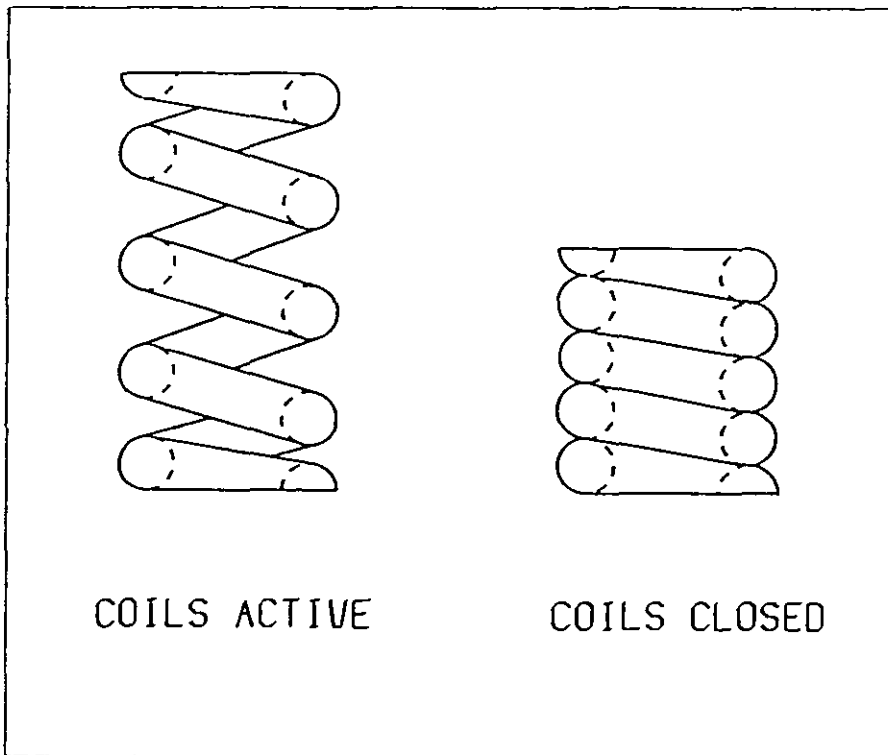

Figure 7.5.0a Coil spring Analogy.



Figure 7.5.0b shows a typical fitted curve using the results previously referred to in the preliminary experiments (Clause 6.3.2). In this graph the results from three independent tests are plotted against the same axes. It must be emphasised that this equation is not intended to represent a definitive relationship for all straw, however it shows clearly the accuracy of the empirical fit and defines suitable constants for a particular set of circumstances.

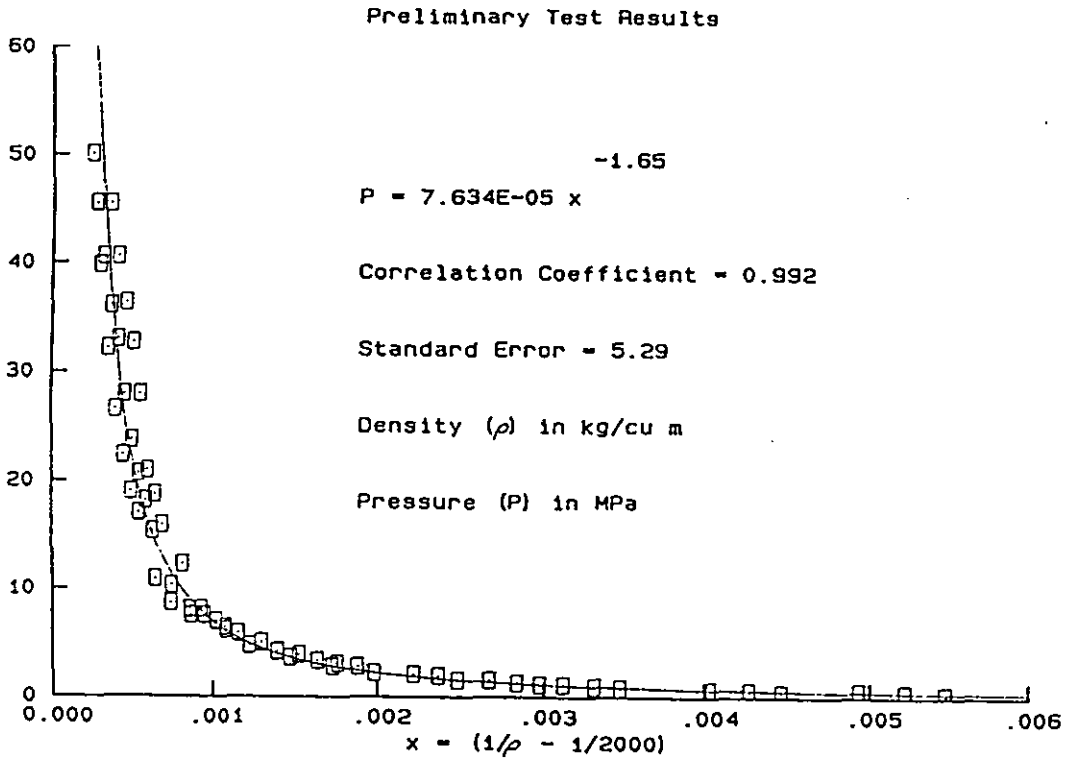

Figure 7.5.0b Fitted Pressure/Density Relationship for Closed Die Tests.

## 7.6 ELASTICITY AND RELAXATION

The graphs presented in figures 7.6.0a and b show the relaxation of rectangular briquettes plotted on a time base. The briquettes were

made from wheat straw in the 55mm X 65mm closed die arrangement previously described. The data demonstrates that a stable density is not reached until at least one hour after formation although between 85% and 90% of the relaxation will have taken place during the first 3 minutes and the initial relaxation is very rapid indeed.

Although the compressed density is known to be a function of pressure, the final density was found to be additionally dependent on the time held under load. This was most evident on samples made at low pressure and the effect of hold time was again non-linear with the greatest proportional benefits occurring in the initial minutes.

The relaxation, then, appears to take the form

$$\rho = (\rho_C - \rho_R) e^{-bt} + \rho_R$$

Substituting for the Relaxation Ratio,  $R = \rho_R / \rho_C$  we get

$$\rho = \rho_C ((1 - R) e^{-bt} + R)$$

---

where  $\rho$  is the instantaneous density  
 $\rho_C$  is the compressed density (a function of pressure for any given material).  
 and  $\rho_R$  is the stabilised relaxed density.  
 $t$  is the elapsed time from release of the load.  
 and  $b$  is a constant for the material condition.

$R$ , the inverse of the Relaxation Ratio quoted in experimental results, is a function of both pressure and hold (under load) time but has also

been found to vary widely according to the orientation of the fibres, so mathematical devices such as this are of use only when comparing like conditions (e.g. for consecutive tests in a series).

In the practical application of the technology, it may be possible to exercise some control over orientation and fibre movements at the final stage by modifying the shape of the dies.

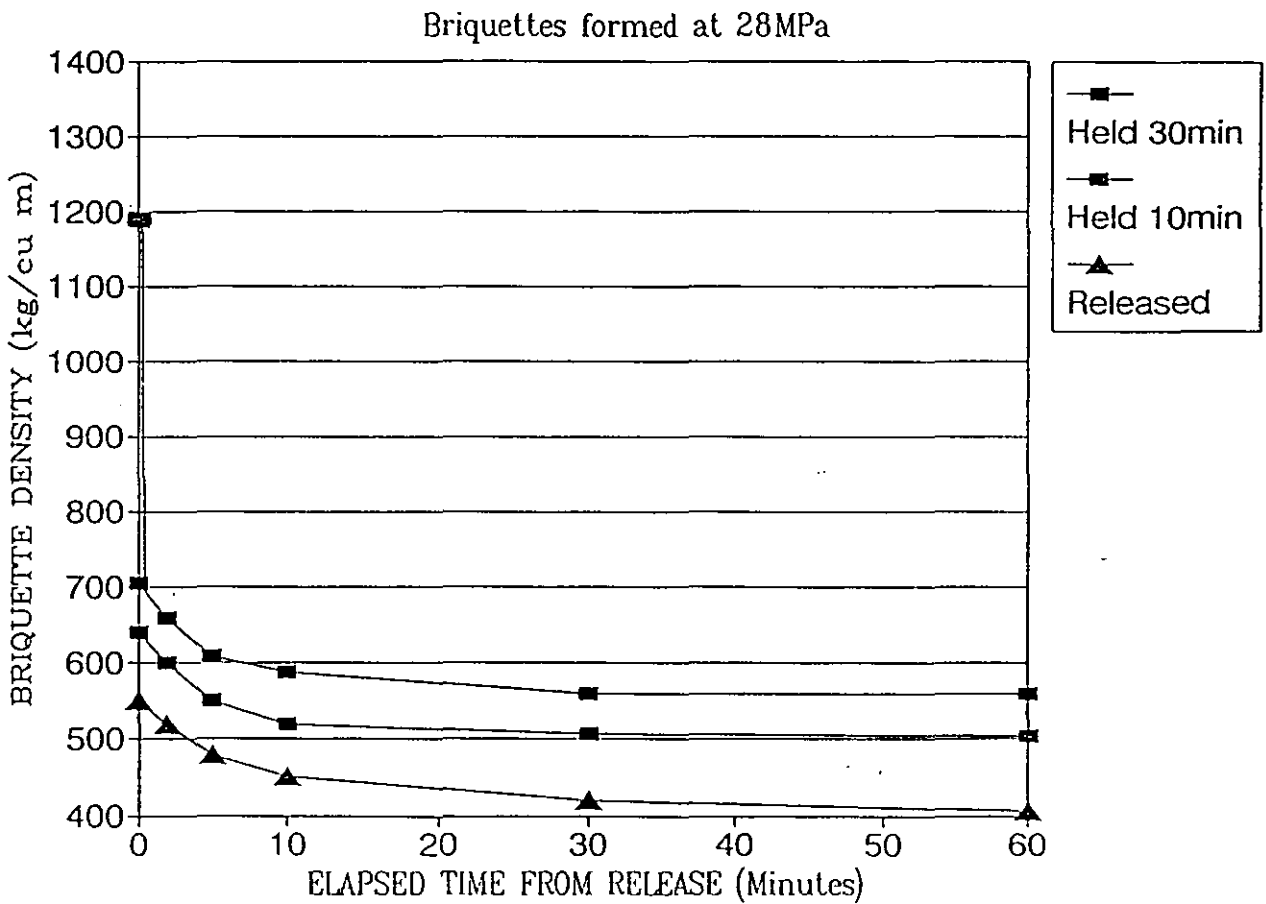

Figure 7.6.0a Relaxation Curves for 65mm X 55mm Briquettes

Briquettes formed at 50MPa

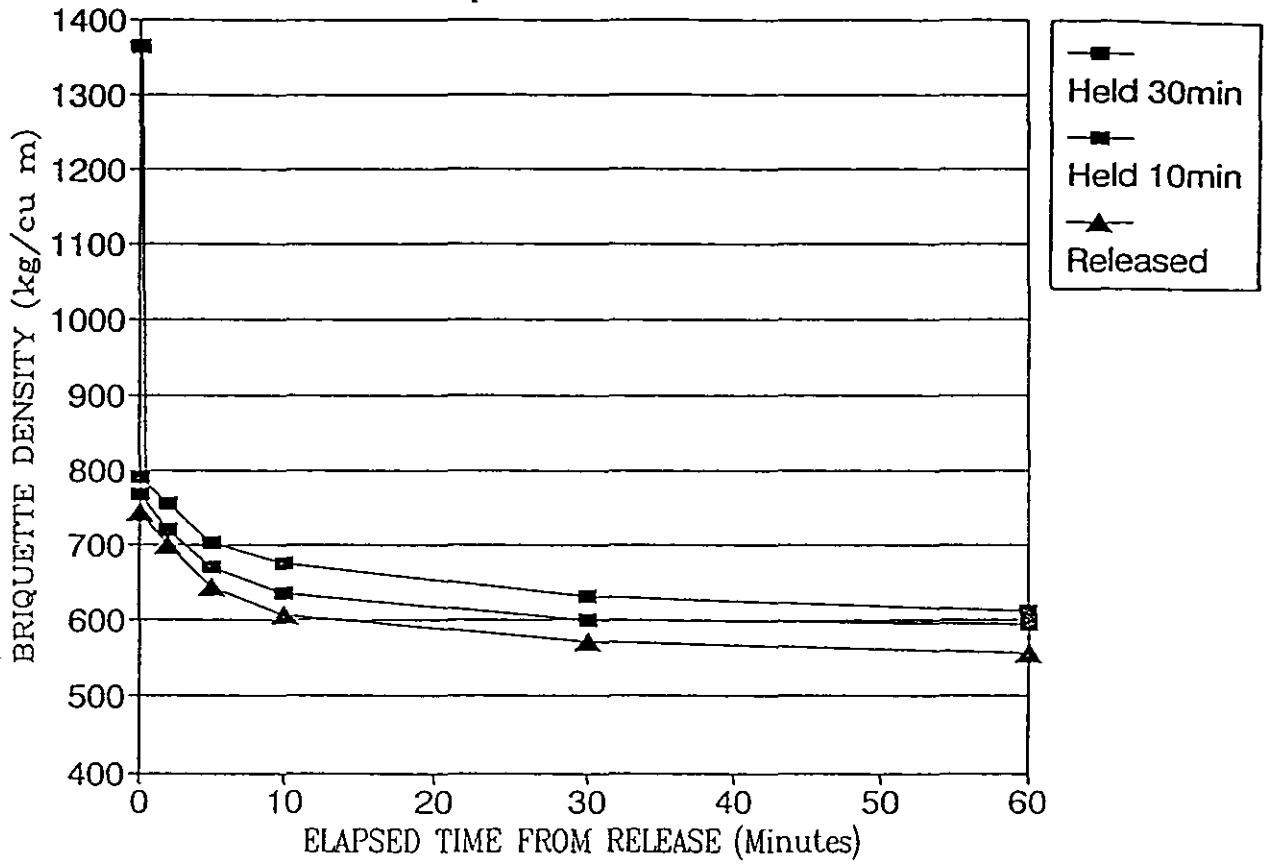
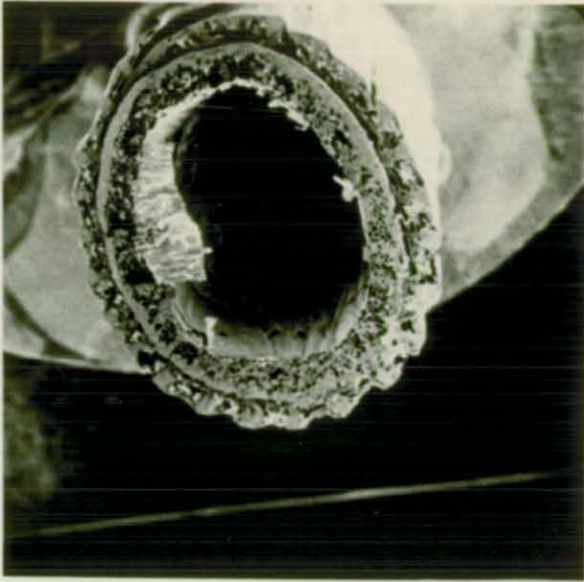
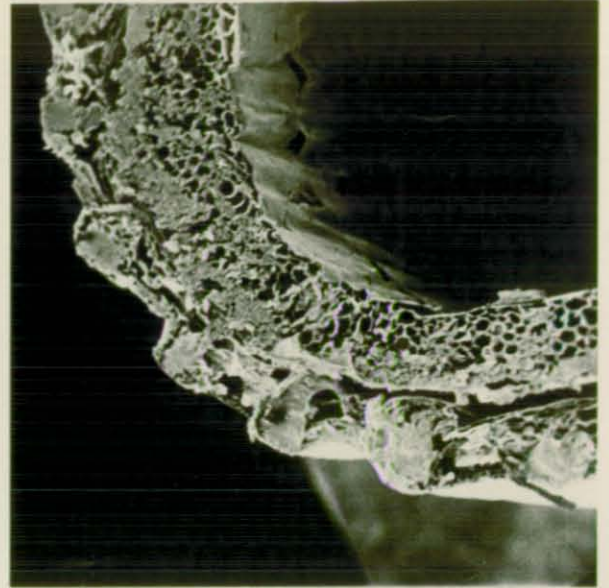

Figure 7.6.0b Relaxation Curves for 65mm X 55mm Briquettes



(a) X 28  
Internode and Leaf Sheath



(b) X 70  
Internode and Leaf Sheath

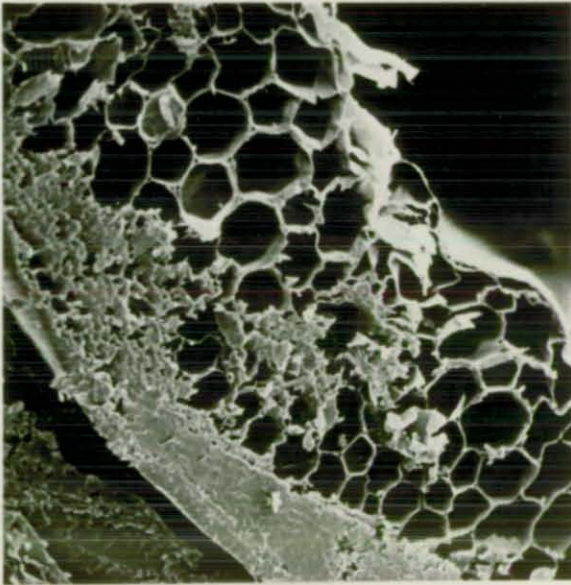

(c) X 270  
Internode

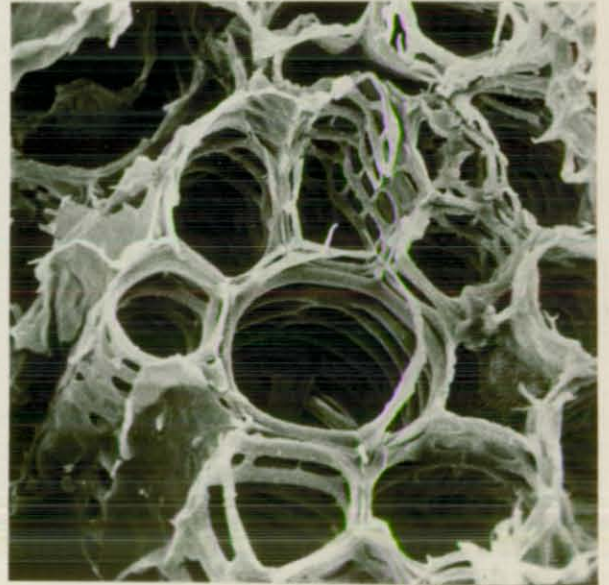

(d) X 2400  
Vascular System



(a)  
Separated layer in the  
Briquette

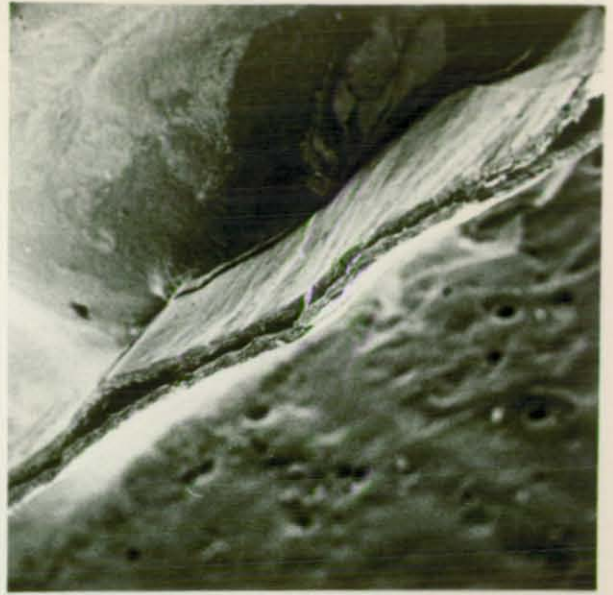

(b) X 65  
Transverse Section through  
an Internode



(c) X 250  
Transverse Section through  
an Internode

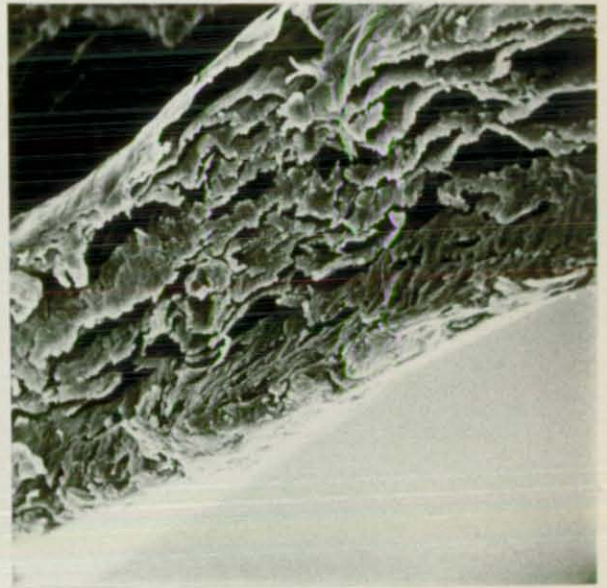

(d) X 1300  
Transverse Section through  
an Internode

PLATE 7.2 STUDY OF STRAWS REMOVED FROM A BRIQUETTE

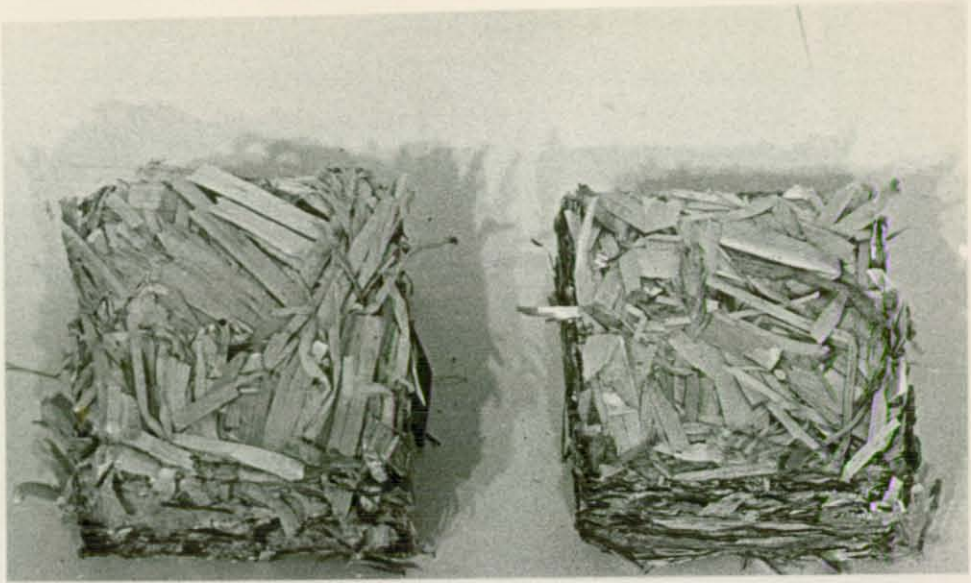

(a)

Vertical Orientation

Control Sample

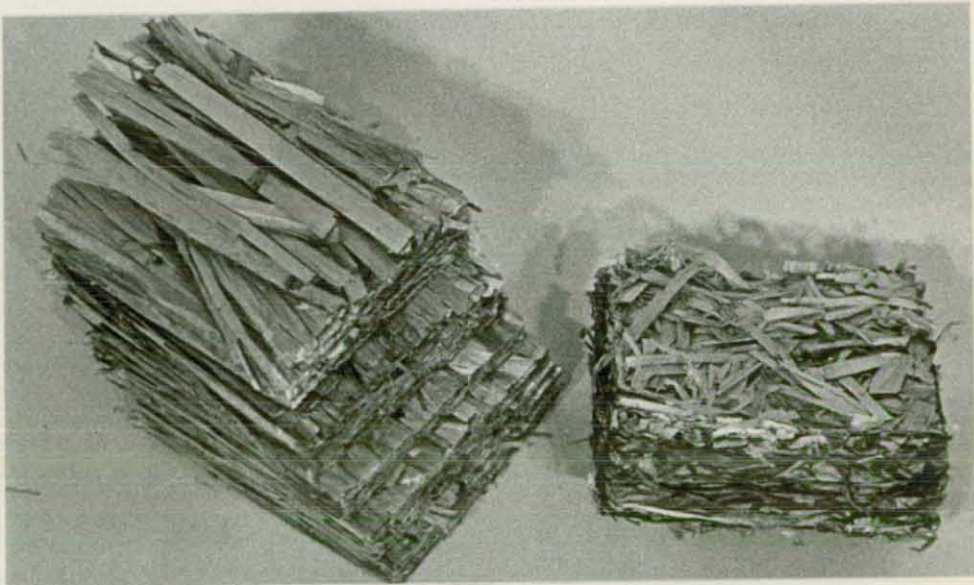

(b)

Horizontal Orientation

Control Sample



(a)

- (a) Whole Straw
- (b) Internodes
- (c) Leaves
- (d) Ear Remnants
- (e) Nodes



(b)



(c)

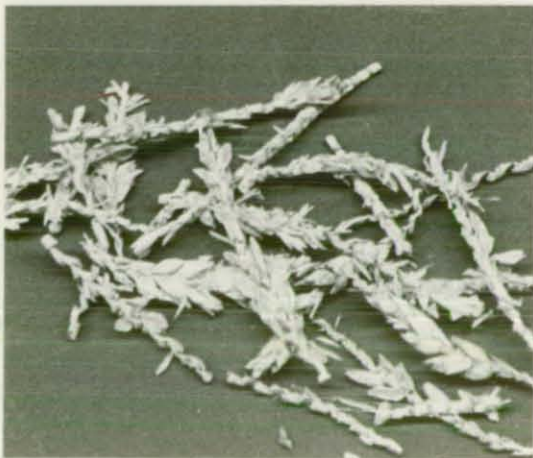

(d)



(e)

PLATE 7.4 SEPARATED WHEAT STRAW COMPONENTS



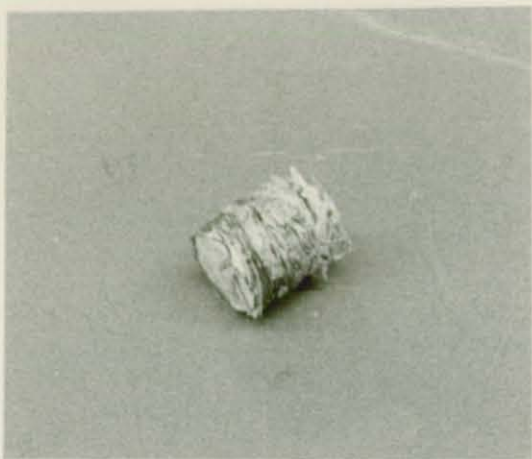

(a)

- (a) Whole Straw
- (b) Internodes
- (c) Leaves
- (d) Ear Remnants
- (e) Nodes



(b)



(c)

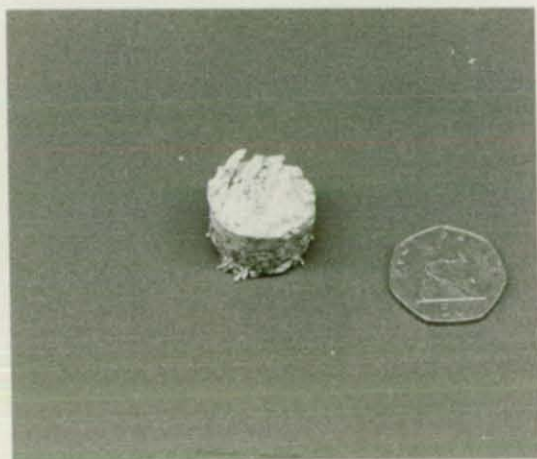

(d)



(e)

PLATE 7.5 SEPARATED WHEAT STRAW BRIQUETTES

## 8. RESEARCH INTO THE EFFECTS OF VARYING THE SHAPE AND DIMENSIONS OF THE DIES

### 8.1 PRINCIPLES AND PROCEDURES

Within the limitations of the laboratory environment, every effort was made to represent the 'live' conditions of the proposed disc compactor. The experiments were performed using three adjacent dies to simulate part of a circular ring of die pockets. Both wheat and barley straw were tested.

After numerous modifications, the existing straw compaction equipment, which had been used for the preliminary experiments, was at the end of its useful life and several deficiencies in its original design had become apparent. A new rig was required with which to conduct a range of further 'static' tests. The Department's Denison 500 kN tensile/compression testing machine had proved effective in applying the load, but at an extremely low velocity (3.5 mm/s) compared with the required operating conditions (hence the term 'static' tests). Standard laboratory load and displacement transducers were easily attached to the machine at various stages in the experimentation.

A new rig was designed and manufactured to accommodate three 2" (50.8mm) square dies, with sliding clearances. (Plate 8.1a). A standard bar size was chosen to reduce considerably the amount of machining on the large number of interchangeable dies which were anticipated, the rolled tolerance on bright bar being sufficiently close for the purpose. The arrangement of the cavities was similar to that previously described in clause 6.3.3; however, the dimensions were smaller than on the previous rig in order to reduce the load

needed to achieve a pressure of  $50 \text{ MN/m}^2$  on three samples at once. The force required would now be approximately 375 kN, which was well within the capability of the Denison press. Additional features of the new test equipment were:

- (i) A step height which was readily adjustable by adding simple packers;
- (ii) Interchangeable heads on the plungers;
- (iii) Relatively easy briquette removal from below the die;
- (iv) A closed height measuring device.

#### General Experimental Method

Unless otherwise stated, the three dies were set to a required step height and packed with randomly oriented straw. The cavity was filled by hand with a known mass and the dies were pressed simultaneously to 375 kN. The load was released immediately the set maximum was achieved. The closed height was recorded and the briquettes removed, weighed and examined. The moisture content of the material was checked periodically using the method normally prescribed for forages, (A.S.A.E. S 358.1, "Moisture Measurement") and while water evaporated from the raw material during storage the moisture content for the test samples was held within the range 8% - 18% (wet basis)\*.

##### 8.1.1 Nomenclature

The preliminary experiments used a fixed step height and proved that shearing was feasible. The re-designed test rig would allow the step

\* A separate investigation into the effects of moisture variations can be found in Chapter 9.

height (s) to be varied in relation to the closed height (h). This was important because, for any size of briquette, the effectiveness of the shear condition would depend, not on the absolute value of 's' but on its magnitude in relation to 'h'. The Step Ratio ( $S_r$ ) will, therefore, be defined as the ratio s/h.

The preliminary tests had also shown that effective shearing also depended on the compressed density: data on low density packages would be of little practical use as durable briquettes would not be formed, so the step ratio was optimised at  $50 \text{ MN/m}^2$  nominal working pressure. As a consequence of using a fixed pressure, 'h' could not be independently controlled. It simply varied in proportion to the charge mass. During the experiments, the mass was selected to give the height required and the closed height was subsequently recorded with the measuring device. It was important that the chosen dimensions should accurately reflect typical 'live' (rotary production machine) values so estimates were made prior to the laboratory work.

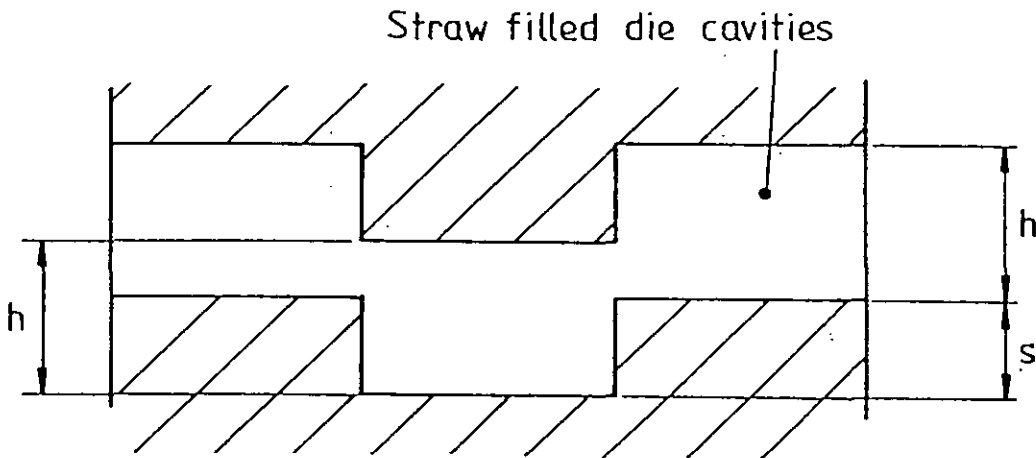

Figure 8.1.1a Die Step Nomenclature.

### 8.1.2 Nominal Parameters

The step heights were chosen to accord with a nominal briquette mass of 63 grammes and compressed density of approximately  $1350 \text{ kg/m}^3$  calculated in the following way:-

For the proposed continuous flow process, compression was assumed to take place in a direction perpendicular to the flow i.e. There would be no longitudinal compression of the swath throughout the machine. As a consequence, the mass of straw making up a briquette of length (1) would be the same as the mass of a similar length of loose swath in the field. If it was further assumed that the cross-section of the swath were constant and that each briquette would be compressed to the same density, it could be seen that the volume of compressed material in the briquette would be directly proportional to the die length.

Using the specified capacity of a field machine; 10 Tonne/hour when travelling at 5 m.p.h. then the mass of straw per unit length would be:

$$10 \times 1000/5 \times 1609 = 1.24 \text{ kg/metre of swath}^*$$

If there is to be no longitudinal compression, then the specific mass of briquettes under compression in the final stage would also be 1.24 kg/m.

So for a die length of 50.8 mm there would be approximately

$$50.8 \times 1.24 = \underline{63 \text{ grammes}} \text{ of straw available.}$$

\* As an additional check, This figure was compared mathematically with a model of a typical wheat yeald of 2.5 Tonne/Hectare.

In order to establish a suitable value for the nominal compressed density of an unspecified straw type at  $50 \text{ MN/m}^2$ , the load/displacement results of seven different straw compression experiments by the author and undergraduate researchers, using three completely different closed die test rigs, were used to plot a generalised pressure/density curve. The range of pressures covered was from zero to more than  $50 \text{ MN/m}^2$  (Graph (i) Appendix I).

## 8.2 DIE STEP DIMENSIONS

### 8.2.1 The Step Ratio Criterion

A series of eight tests were carried out with two different species of straw using variable-step flat faced dies.

#### Experimental Constants (see Clauses 8.1.1 & 2)

Nominal Briquette Mass .....	63 g
Nominal Charge Mass .....	189 g
Applied Force .....	375 kN
Nominal Maximum Pressure .....	$50 \text{ MN/m}^2$
Projected Compressed Density .....	$1350 \text{ kg/m}^3$
Projected Closed Height .....	18 mm
Moisture Content, Wheat Straw (w.b.).....	14.0 %
Moisture Content, Barley Straw (w.b.).....	11.3 %

Results

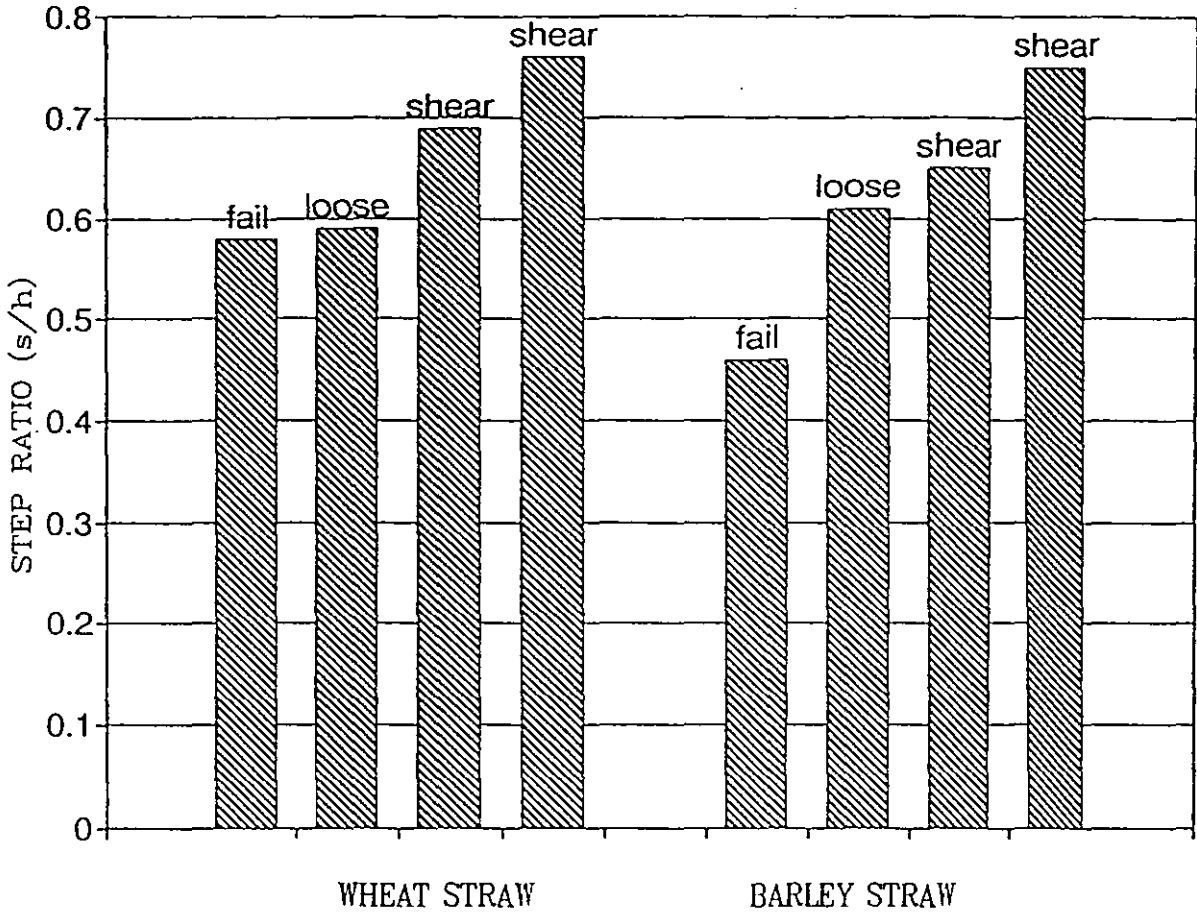

Figure 8.2.1a Step Ratio Optimisation (flat faced dies).

For successful shearing of rectangular briquettes it was found that the step height 's' should not be less than 65% of the closed height 'h'. Plate 8.2 shows samples from tests at various step ratios.

Allowing for variations in straw type and condition a minimum practical value was established:

$$S_r = 0.7.$$

### 8.2.2 The Energy used in shearing

Confirmation that the energy consumption remains virtually, unchanged when separating steps are introduced, was demonstrated by comparison between the following typical test results. In both examples acceptable briquettes were formed:

Test (to 50 MN/m <sup>2</sup> )	Compression	Compression and Shearing
DIE	SINGLE	TRIPLE
Straw Mass (g)	65	174
Work Done (J)	1420	3930
Specific Energy Consumption (MJ/tonne)	21.8	22.5

Table 8.2.2a The Energy Used in Shearing.

The results indicated that very little additional energy was required to achieve separation by this method. The experiment was too limited to accurately quantify the shear energy, but further investigation was unnecessary as it had established that the machine power needed to sever the 'rope' could be neglected.

For the closed "single" die test the components of the test rig were assembled as depicted in Plate 8.1b. A single briquette was produced by applying force to the central plunger only.

### 8.3 THE EFFECT OF VARYING BRIQUETTE SIZE ON ENERGY CONSUMPTION

In order to achieve the optimum die shape, it would very likely be



necessary to alter the cavity dimensions and these changes would result in an alteration to the final mass of the individual briquettes. It was, therefore, vital to be aware of any substantial change in the energy requirements for making the required tonnage of briquettes in the form of smaller or larger packages. M.J. O'Dogherty and J.A. Wheeler<sup>(35)</sup>, using circular closed dies, found that increasing the amount of straw in the die resulted in an exponential increase in the relaxed wafer density without any change in specific energy. In addition, they found that the pressure required to form a wafer increased exponentially with both relaxed density and die diameter. This would suggest that a taller, smaller section briquette would be more durable, would require less force from the compacting discs but would need the same total amount of energy to produce the tonnage.

To verify that the specific energy level does not change if the charge mass is increased, the three-die apparatus was loaded with two significantly different charges from a single sample of wheat straw. Prior to the tests, the nominal compressed height (h) of the packages were calculated and the die steps (s) were pre-set to give  $S_r = 0.7$ . The applied load was recorded for incremental reductions in the package height and the loading curves plotted (Graph 8.1). The work done in each case was estimated from the area enclosed by the curves.

Results

For three briquettes

Test No.	Charge Mass(g)	Compressed height (mm)	Work Done(J)	Ave. Relaxed Height(mm)	Ave. Relaxed Density (kg/m <sup>3</sup> )
1	174	17.5	3930	31	725
2	284	29	6300	60	611

Referring to Chart 1, Appendix I, (tests 1 to 10).

Note; In these tests the outer briquettes were disregarded and the comments, in each case, apply to the centre briquette as only this sample was representative of continuous flow conditions.

For ease of future reference the following annotation was adopted:

- Die Arrangement 'A' ..... e.g. Tests 1 & 2.
- Die Arrangement 'B' ..... e.g. Test 3.
- Die Arrangement 'C' ..... e.g. Tests 4, 5, 6 & 9.
- Die Arrangement 'D' ..... e.g. Test 7.
- Die Arrangement 'E' ..... e.g. Test 8.
- Die Arrangement 'F' ..... e.g. Test 10.

Die arrangement 'A' had rectangular dies with a step height equal to 70% of the closed height and these may be used for direct comparisons. Arrangement 'B' had substantial horizontal clearances added. Style 'D' also had rectangular dies but the step ratio was increased to 0.9. With arrangement 'C', the centre dies had 8 mm x 45° chamfers all round and the end dies were provided with a chamfer on the edge adjacent to the centre die only, to represent the correct edge condition (the end briquettes would be ignored anyway). Plate 8.3 shows arrangement 'F' and the results from test 10 in which opposite dies had different depths and chamfers with 45° on the shallow die and 32.5° on the deep die. (The step height was 4.5 mm). The end dies were, again, only chamfered on the edge adjacent to the centre die. Arrangement 'F' was thought to be the next logical stage in the development of the shape used for tests 9.

## Observations

(i) Horizontal clearance between dies (as in Style 'B') drastically reduces briquette quality and the ability to separate by shearing is impaired.

(ii) Of the tests which used rectangular shaped dies, the best results were obtained by allowing the dies to approach one another with the minimum clearance (Arrangement 'D'). There would appear to be a quality advantage in maximising the step ratio in accordance with the mechanical clearances allowable.

(iii) The addition of chamfers could result in a reduced relaxation ratio.

(iv) One of the most promising briquettes was apparently produced by style 'C' dies in test 4, but quality deteriorated when the dies did not approach so closely (test 5). There was some evidence to suggest that extraction problems might also be alleviated by the inclusion of Chamfers. The chamfers had been added to apply lateral pressure locally in the corners of the package where crumbling and disintegration was most prevalent. The lateral pressure would induce movements to interlock the fibres.

(v) Spraying the dies with water resulted in a much poorer briquette, as demonstrated by test 6.

### 8.4.2 Energy Factors

To compare the energy required to produce a briquette in a rectangular

die with square edges to that required for a briquette of similar mass using dies with shaped or chamfered edges.

Referring to Chart 1, Appendix I, tests 11 to 14.

In order to eliminate any errors which might be created by measuring the energy consumption with three cavities of unequal volume it was decided to conduct this comparison using single closed dies. It could be assumed that the energy needed to shear briquettes was very small compared with the overall energy required to compress the straw (see clause 8.2.2).

Experimental Constants:-

The mass of straw was kept as constant as experimentally possible for each test: 63g.

Test 11 - Square closed die, max. force 125 kN ( $50 \text{ MN/m}^2$ )

Test 12 - Square closed die, max. briquette density  $1430 \text{ kg/m}^3$  (fixed value of h)

Test 13 - Shaped closed die, max. force 125 kN ( $50 \text{ MN/m}^2$ )

Test 14 - Shaped closed die, max. briquette density  $1430 \text{ kg/m}^3$  (fixed value of h).

Loading curves for test 12 with square dies (Graph [ii], Appendix I) were compared with test 14 using dies with chamfered corners (Graph (iii), Appendix I). To take account of any slight variations in experimental technique, the energy consumption was calculated using two different methods:

- (i) Comparing the two curves at the point where the compressed density reached  $1430 \text{ kg/m}^3$  (purely a convenience figure).
- (ii) Comparing the two curves at the point where the mean applied pressure reached  $50 \text{ MN/m}^2$ .

METHOD	Test 12 (Square)	Test 14 (Chamfered)	% difference
Energy required for test (in Joules)			
(i)	1548	1660	7.2
(ii)	1418	1415	-0.2

At the specified production rate for the field machine, these figures equate to:

METHOD	Test 12 (Square)	Test 14 (Chamfered)
(i)	66.2 kW	69.6 kW
(ii)	60.6 kW	59.6 kW

From these results it was concluded that the addition of chamfers to dies does not increase the specific energy requirements by any significant amount; also that the overall power requirement for the production of these types of briquettes, at a rate of 10 tonne/hr., will be in the order of 60-70 kW (excluding losses and power required for forward motion).

The tests also confirmed that the addition of chamfers caused a 10% reduction in relaxation rate but balanced against this improvement was a reduction of about 5% in initial compressed density for any given load.

## 8.5 FURTHER EXPERIMENTAL RESEARCH WITH CHAMFERED DIES

The Chart 1 results, obtained with chamfered dies, not only represented an apparent reduction in the overall relaxation ratio from around 2.2 to about 1.9 but also gave an improvement in the visual appearance of the briquettes. Although type 'C' die appeared to produce a very promising solution, it must be noted that the tests represented only an approximation to a multiple system of similar shaped dies. For reasons of manufacturing expediency, the set of three dies used in the tests had not been the same. Even though the two outer dies presented a similar edge condition: with the dies closed, the volumes for the end dies were larger than that of the centre cavity. Consequently, it could be assumed that the briquettes produced in the central die cavity were absorbing more than one third of the total applied energy thus making direct qualitative comparisons with those produced in rectangular dies invalid. (For this reason, this important but possibly misleading set of results has been removed from the main body of the thesis). Clearly, further tests were needed with sets of dies having identical cavities.

### 8.5.1 Application of the Step Ratio Criterion to Chamfered Dies

The step height ( $s$ ) and the overall height ( $h$ ) were previously defined in relation to rectangular, square cornered dies and the minimum step ratio ( $S_r$ ) found empirically to be 0.70 for efficient shearing. The introduction of chamfers on all four sides of the dies presented new problems: it was initially unclear how the criterion should be transferred to these dies and, indeed, whether the empirical result would still remain valid.

Figure 8.5.1a shows the arrangement of three consecutive chamfered dies. The close proximity of the raised edges of the new design suggested that a cutting action would be take place, analogous to the action of wire cutters, and that this would aid separation and possibly allow for a reduction in the step ratio.

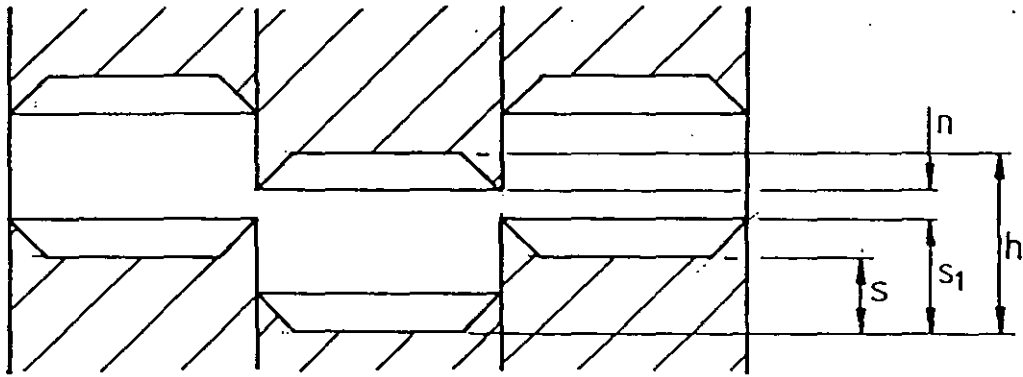

$s$  = step height.     $s_1$  = lip height.     $n$  = nip.  
 $h$  = overall compressed height.

Figure 8.5.1a Chamfered Die Nomenclature.

For tests 4,5,6 and 10 of Chart 1, a lip height  $s_1 = 12.5$  mm had been chosen to give  $s_1/h$  approximately 0.7. Referring to the above diagram, it can be seen that this gives  $s = 4.5$  and  $s/h$  only 0.2. Somewhat surprisingly, perhaps, the initial experiments had been encouraging. Test 8 had demonstrated how the straw could be cut by arranging  $s_1$  equal to the chamfer height ( $s/h = 0$ ) albeit with a dramatic reduction in briquette quality. However, when these tests were repeated, using three identical sets of dies incorporating chamfers on all four sides and equal cavity volumes, the results were very different and it soon

became evident that the shearing criterion should be based upon the original step ratio,  $s/h$  not  $s_1/h$  and that the cutting effect could be virtually disregarded as ineffective.

With deep chamfers the practical value of  $S_r$  will thus be limited by the specified need to maintain clearance between the discs at all times, i.e. The nip, ( $n$ ) which is a function of  $s$ ,  $h$  and the chamfer depth,  $d$  must be positive.

Repeat tests with Three 'Identical' Sets of Chamfered Dies.

The table, below shows a compilation of a series of experiments which were conducted to establish the shearing criterion, when using sets of identical chamfered dies like those depicted in figure 8.5.1c. The step height was varied as in clause 8.2.1. Similar results were obtained with both wheat and barley straw of between 10-15% w.b. moisture content. These results showed a marked contrast with those listed in Chart 1 where unequal dies were used.

Die Chamfers	s (mm)	h (mm)	$S_r$	n (mm)	Result	Comment
8 mm x 45°	0	23	0	7	No separation	Compare Chart 1, test 8
8 mm x 45°	3	24	0.13	4	No separation	
8 mm x 45°	4.5	23	0.2	2.5	No Separation	Compare Chart 1, tests 4,5,6 & 10
8 mm x 45°	6	23	0.26	1	No Separation	
8 mm x 45°	9	23	0.39	-ve	Good sample	Overlapping dies
6 mm x 45°	9	24	0.38	3	No separation	Smaller chamfers to allow die clearance (Type F, Chart 1).

Table 8.5.1b Results with equal dies.



It was decided to adopt a theoretical approach, as considerable time and effort would have been expended by continuing these trial and error methods of determining the shearing criterion.

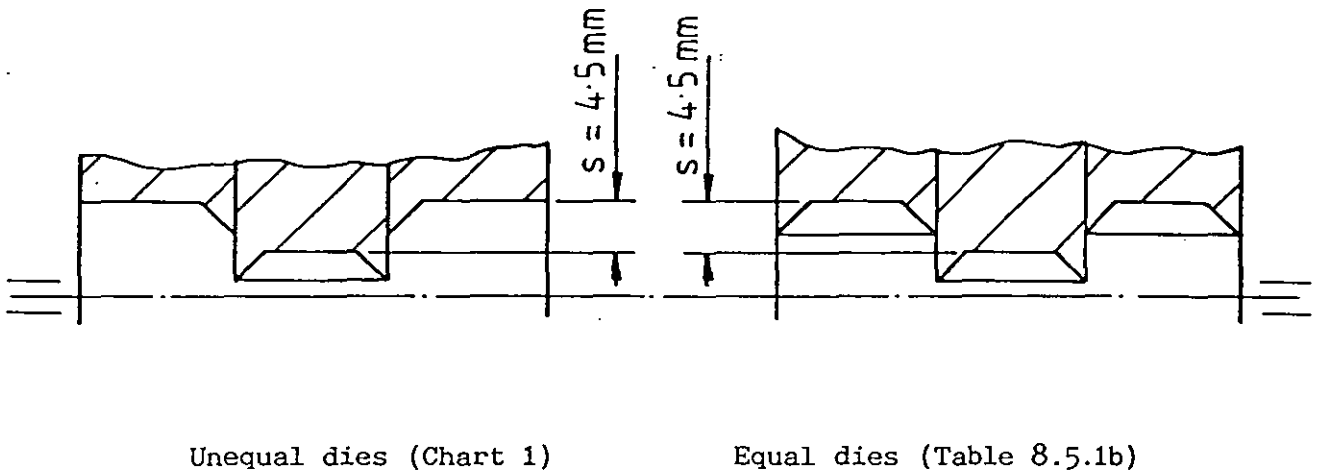

Figure 8.5.1c Die Arrangements

Contrasting the die arrangements used in the two sets of tests: the difference in closed volume between the centre and end cavities in arrangement (a) would create a pressure difference across the three briquettes; whereas in arrangement (b) each briquette would absorb an approximately equal load.

The relationship between reactive pressure and density has been previously defined (Section 7.5) to take the form

$$P = a ( 1/\rho - 1/\rho_0 )^{-b}$$

Using the results of single die test 12, for which loading curves had been recorded, the constants for the material were empirically established (See Graph 8.2).

$$P = 1.713 \times 10^{-4} (1/\rho - 1/2000)^{-1.52}$$

Considering the parameters of test 5 (Chart 1) as typical of the type and assuming that each cavity contained an equal mass of straw (72 g), the reaction on each die could be estimated, thus:-

		CENTRAL CAVITY	END CAVITIES
Volume	mm <sup>3</sup>	49965	58684
Density	kg/m <sup>3</sup>	1441	1227
Pressure	MN/m <sup>2</sup>	75.2	36.0

Hence it could be deduced that the applied load of 375 kN (nominally 50 MN/m<sup>2</sup> across the total cross section) would need to be increased to 582 kN (75.2 MN/m<sup>2</sup>) if the three briquettes in arrangement (b) were to receive the same loading as the centre briquette had received in arrangement (a). Unfortunately the predicted load was beyond the capacity of the testing machine.

Nevertheless the experiment, using dies in arrangement (b) and a similar charge, was repeated to the maximum load available and this, at least, confirmed that an increase greater than 33% would be necessary in order to achieve separation with three identical cavities and no increase in step height.

Die Chamfers	s (mm)	h (mm)	S <sub>r</sub>	n (mm)	Applied Load (kN)	Result
8 mm x 45°	4.5	21.5	0.21	1	500 *	No Separation

\* Maximum capacity of testing machine.

## Conclusions from the Comparison

1. The Chart 1 arrangements could not be used on a continuous process machine where each pair of die cavities would need to be the same.
2. The centre briquettes produced in the Chart 1 experiments, using chamfered dies, received about 17% more pressure than required by the experimental basis for this work. This additional work done could possibly explain the high compressed density and particularly low relaxation rate figures obtained from this set of experiments (less than 2.0).
3. With deep chamfers and a step ratio of only  $S_r = 0.2$ , raising the applied pressure by up to 30% did not allow the briquettes to shear.
4. The chamfers did not produce a significant cutting action when the mass was compacted uniformly in each cavity but when the end cavities were less tightly packed (as Chart 1 experiments) some lateral movement was produced by the chamfers and this aided separation.
5. In a disc type compactor, with identical adjacent cavities, the cutting action of the chamfers would not be present; the straw must, therefore, be sheared in exactly the same way as with square cornered rectangular dies. Hence, for any shape of die cavity the shearing step height ( $s$ ) would be equal to the shift of the centre-line of the compressed mass.

$$\text{i.e. } S_r = s/h = 0.7.$$

---

### 8.5.2 Mathematical Optimisation

The shearing criterion was applied mathematically to the chamfered dies (type 'C', Chart 1) in order to establish the maximum depth of chamfer under the given conditions for the laboratory test samples of known cross section, mass and closure height. Taking a charge mass as 63 g pressed to 50 MN/m<sup>2</sup>, the maximum chamfer which could be accommodated, using the dimensions of the test equipment, was calculated to be 2.9 mm. If the chamfers were made any deeper, the dies would intersect.

It would be highly desirable if a combination of the various parameters (length, width, height, charge mass, chamfer depth, chamfer angle and die clearance) could be found which allowed an increase in this maximum chamfer depth while still maintaining the shear ratio. A process of optimisation using numerical methods was, therefore, applied which is fully detailed in Appendix II.

### 8.5.3 Tests with Die Shapes Resulting from the Mathematical Optimisation

The analysis emphasised the severe limitations to die shape variation imposed by the stepped disc configuration and in particular by the specified requirement to maintain positive radial clearance between the two discs. It confirmed that deep chamfers of the type used in the Chart 1 experiments could not be used in practical machinery.

For the purposes of visual comparison, two experiments were performed using the guidelines from the mathematical optimisation applied to the existing dimensions of the laboratory equipment.

## Material Condition

Two straw varieties were again used for these experiments; wheat and barley.

### Experiment 1

Using 3 mm x 45° chamfers on all four sides of all dies and a step ratio:  $S_r = 0.65$

---

	<u>WHEAT</u>	<u>BARLEY</u>
Moisture content (wet basis)	14.0%	11.3%
Charge mass (g)	192	195
Briquette mass (g): Left	60	62
Centre	72	74
Right	60	59
Compressed height (mm)	19.5	19.9
Die clearance (mm)	1.0	0.5
Step ratio	0.64	0.66
Applied force (kN)	375	375
Max. Pressure (MN/m <sup>2</sup> )	50	50
Sheared?	YES(except for a single fibre)	YES
Relaxed density-mean (Kg/m <sup>3</sup> )	564	548
Relaxed density-Central die (kg/m <sup>3</sup> )	635	624

---

Table 8.5.3a

Visually the central samples were the best examples although, all the briquettes were of a moderately neat appearance with only a few loose strands mainly on the top and bottom flat faces. The chamfered corners appeared to aid bonding of the corner fibres.

Experiment 2

Using dies machined to a 3 mm deep central apex with four flat triangular chamfers as depicted in the figure.

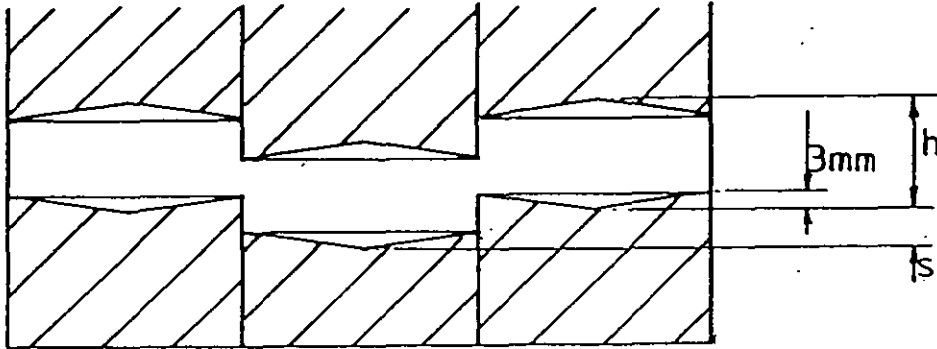

Figure 8.5.3a Experimental die shape

		<u>WHEAT</u>	
Moisture Content (wet basis)		14.0 %	
Charge Mass (g)		183	
Briquette mass (g):			
	Left	57	
	Centre	70	
	Right	56	
Compressed Height (mm)		23	
Die Clearance (mm)		2.0	
Step Ratio (s/h)		0.65	
Applied Force (kN)		375	
Max. Pressure (MN/m <sup>2</sup> )		50	
Sheared?		YES	
Relaxed Density-Mean (kg/m <sup>3</sup> )		590	difficult to
Relaxed Density-Central die (kg/m <sup>3</sup> )		678	measure accurately

Table 8.5.3b

Visually these briquettes were not significantly different from earlier samples using flat faced dies. The additional cost of producing these shapes would, therefore, appear to be unjustified.

## 8.6 DIE DRAUGHT

One common feature, which was noticed while performing many of the preceding experiments, was the difficulty experienced in removing formed briquettes from the dies. On several occasions briquettes were broken or damaged because they had to be prised out of the cavities and tests had to be repeated. The situation was somewhat alleviated by the design of the test rig which allowed the lower dies to be completely removed following the forming process. The briquettes could then be pressed clear of the bottom of the apparatus with the upper dies giving free access to both sides of all three briquettes; nevertheless, difficulties were still occasionally experienced.

In a continuous process machine, where power efficiency requirements would be of great importance, the mechanical removal of formed briquettes from the dies would likely be one area of relatively small but still appreciable energy consumption. It would be wise, therefore, when optimising the design of die cavities to take advantage of any modifications which reduce this additional drain on the available power source.

Experiments were conducted to examine the effect of including small draught angles, ( $\delta$ ) on the laboratory briquetting equipment: the tests used two specially prepared sets of dies which included draught angles of  $5^\circ$  and  $10^\circ$  on the central cavity (Figure 8.6.0a). The dimensions were chosen to distribute the compressive load as evenly as possible across the straw charge.

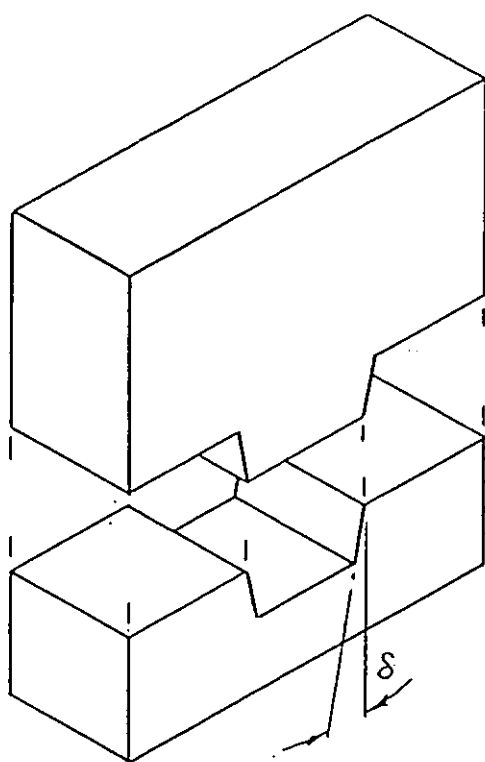

Figure 8.6.0a Draught Angle Investigation - Die Configuration

The outer samples were disregarded but the central packages were examined for ease of extraction from the dies and for visual appearance.

#### Observations

In both cases durable briquettes were formed. They were removed from the dies much more easily than on previous tests. A sharp tap released the samples.

The sides of the briquettes which had contacted the sloping faces of the dies had a cleaner, rather shiny appearance.



There was no appreciable difference in the ease of extraction, or in the appearance of the sloping faces, between the samples from either draught angle.

The shear plane edges A and B, described by Figure 8.6.0b, were the most untidy. The larger slope of the  $10^{\circ}$  draught, which made the angles at these edges more acute, gave an inferior appearance. In addition, the less symmetrical shape caused by the larger draught angles was not so aesthetically pleasing.

It was concluded that the addition of draught angles to the dies would aid extraction, reducing the overall consumption of energy. It is also likely that the reduced extraction forces would result in less breakage of the formed briquettes. The experiment indicated that, with no other changes to the square edged die shape, the smaller draught angle ( $5^{\circ}$ ) was preferable.

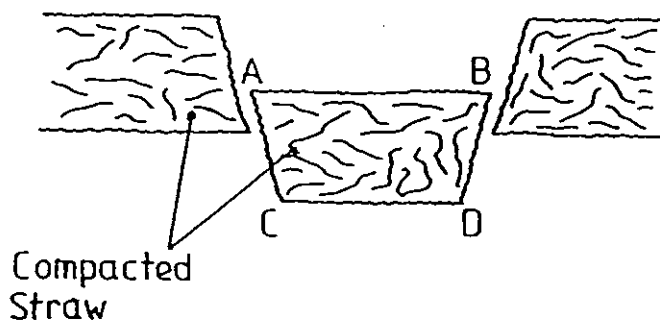

Figure 8.6.0b

## Applications Note

The equipment used for these experiments permitted draught angles on only two sides of the briquette; sufficient, in this case, because the upper dies containing the centre package could be pressed clear of the side walls of the rig after forming. Application of these principles to a disc compactor machine would require draught on all four sides of the briquette to be effective.

### 8.7 DIE DESIGN RESULTING FROM A COMPILATION OF THE PRECEDING RESEARCH

#### 8.7.1 Type 'G' Dies

The foregoing investigations gave a greatly enhanced basic knowledge of many of the elements of die design which would affect the formation of good quality, durable fuel briquettes. A new die configuration was designed and manufactured to accord with the knowledge gained and combine many of the most desirable features into a single cavity shape.

The features which were thought to be most significant were:

- (i) All top and bottom corners should be chamfered at  $45^{\circ}$
- (ii) Step ratio should be 0.7
- (iii) Chamfer depth should be the maximum compatible with the step ratio criterion
- (iv) All side corners should be radiused
- (v) All deep side walls should be given a small draught angle.

It was noted that a large land in the top corners of the dies would not be acceptable as it had been found that straw would not readily migrate sideways under a vertical load; if lands were present, some straw would inevitably become trapped between them creating a jam condition.

For expediency, and because of prevailing time-scale constraints imposed by the project sponsors, it was deemed essential that the experiments should retain the same 3-die test rig so the design features had to be adapted within the physical constraints thus imposed.

The resulting die design, (designated Type G), along with a single briquette of wheat straw formed to  $50 \text{ MN/m}^2$  can be seen in plate 8.4. The draught angle chosen in this case was  $12^\circ$ , not  $5^\circ$  as originally recommended, because the larger angle would give additional strength to the sidewalls of the dies which have only limited support in the existing rig. Experience has subsequently indicated, however, that this was the better choice because the finished briquettes were given a remarkably smooth finish down their angled faces due to the bruising effect of these slopes. The  $45^\circ$  chamfers at the bottom of the deep dies were omitted for ease of manufacture but the corners were filled to give smooth radii. Type G die dimensions appear in Appendix I along with a full set of experimental results from the subsequent test series (Chart 2).

The briquettes thus formed showed subjectively significant quality improvements on packages formed with simple rectangular shapes. The reasons for the perceived improvements were clearly associated with the application of tri-axial pressure on the straw through the

sloping sides of the dies and with the removal of sharp corners in which fibres failed to interweave effectively. The next phase of the research would attempt to quantify the quality effects and examine other external factors which would affect the field process.

#### 8.7.2 Summary of the effects of Die Shape

1. Briquettes should be compressed to an average density of  $1350 \text{ kg/m}^3$  to achieve a relaxed density of at least  $500 \text{ kg/m}^3$ .
2. The principle of the separating technique, in the formation of individual briquettes, is the shearing of a continuous feed of straw through the compactor. Separation by cutting between two vee shaped blades proved ineffective.
3. Compaction discs should close to minimum clearances consistent with manufacturing tolerances. Clearance between the discs could be reduced to zero at the extremes of tolerances on components parts; when the machine is working, a gap would appear between the discs due to the high separating forces.
4. All internal edges and corners of die pockets should be radiused or chamfered. Experimental results have shown that these detail features aid the bonding of the straw where some edge fibres might otherwise remain loose.
5. The sizes of chamfers (radii in deep pockets) should be as large as possible while still satisfying the shearing criterion  $s > 0.7h$ .
6. The maximum size of chamfers is determined by the width ( $w$ ) and the

length (l) of the die pocket. A reduced width increases the chamfer depth, whereas changes in length have little effect. The maximum chamfer should be decided with reference to the other die pocket dimensions.

7. A further advantage of chamfers is that they create an increased pressure around the periphery of the briquette.

8. Draught angles of about  $10^{\circ}$  should be included in the deep dies, thereby considerably aiding extraction and also reducing the overall power requirement. In addition, inclusion of these angles tends to improve the visual appearance of the briquettes.

9. Wiper guides should be provided on each of the open sides of the die rings to strip excess straw away from the cavity edges and ensure that the material does not become entrapped between the walls of opposing cavities. This requirement is essential for good quality briquettes and prevention of jam conditions.

10. It is important that the width of the input from the precompactor should not be greater than the width of the dies (w).

11. In order to achieve efficient shearing and good quality briquettes, it is essential that the rotating discs should not drift out of phase.

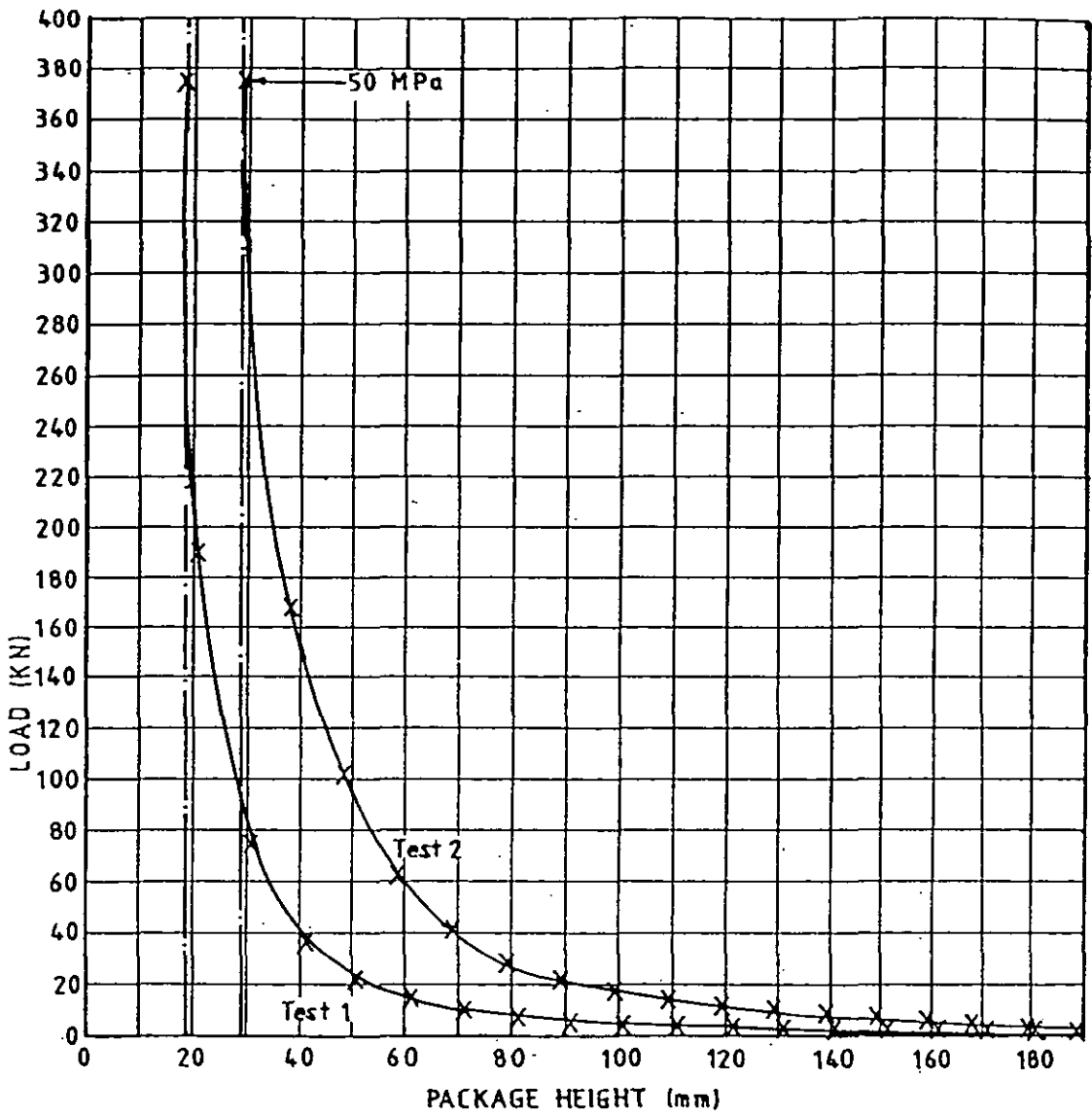

TEST NO	CHARGE MASS (g)	AREA UNDER CURVE (mm <sup>2</sup> )	WORK DONE (J)
1	174	1965	3930
2	284	3150	6300

Graph 8.1 Specific Energy Experiment

Graph 8.2

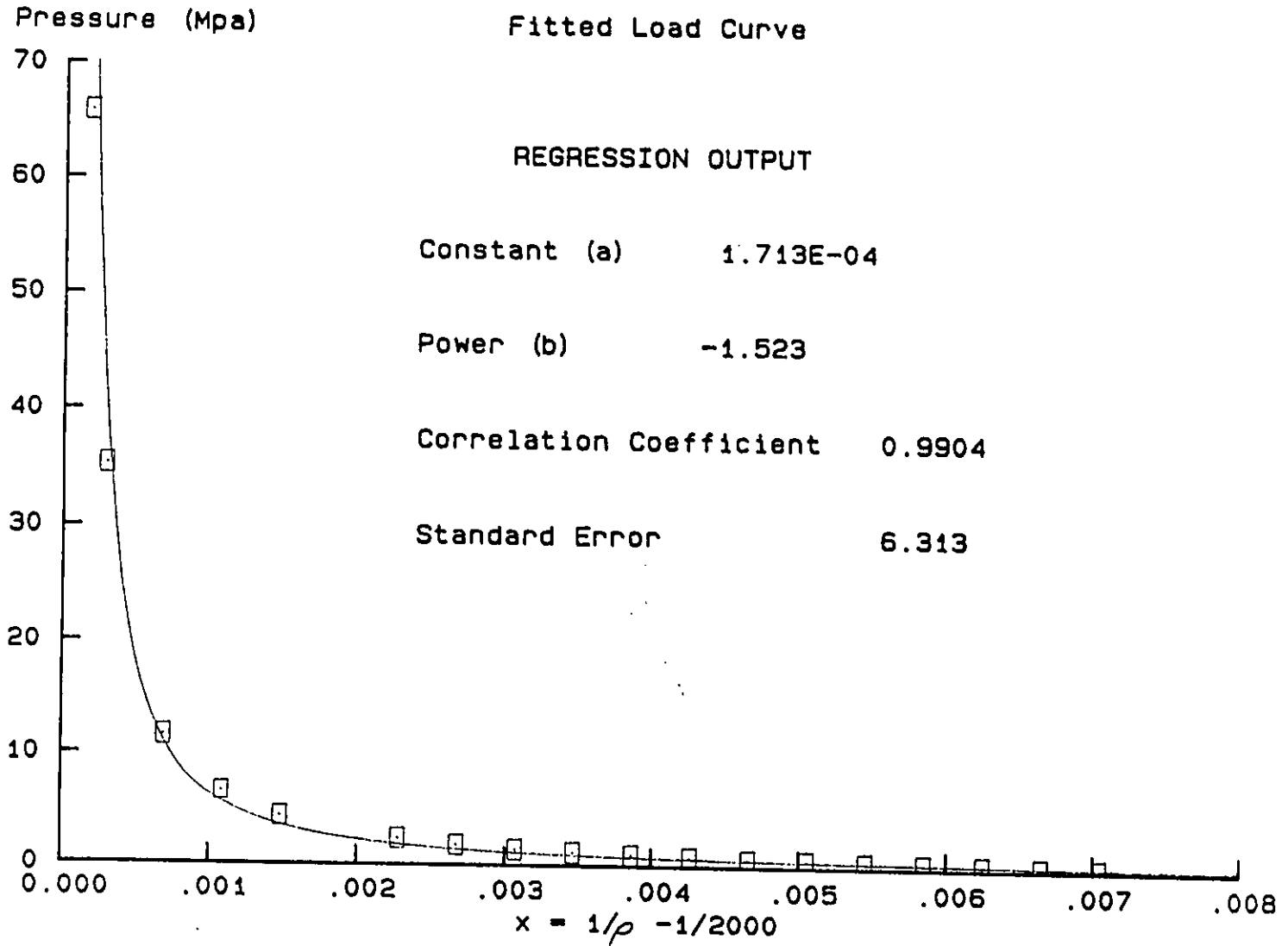

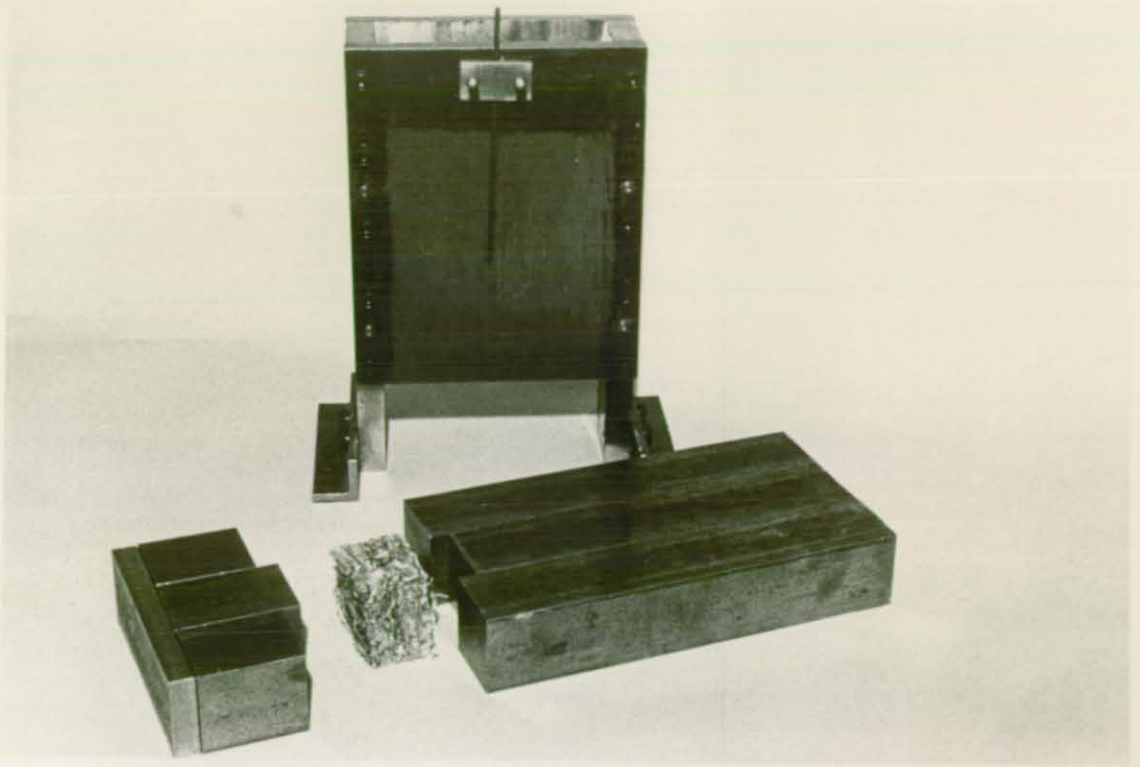

(a) 3 - Die Apparatus

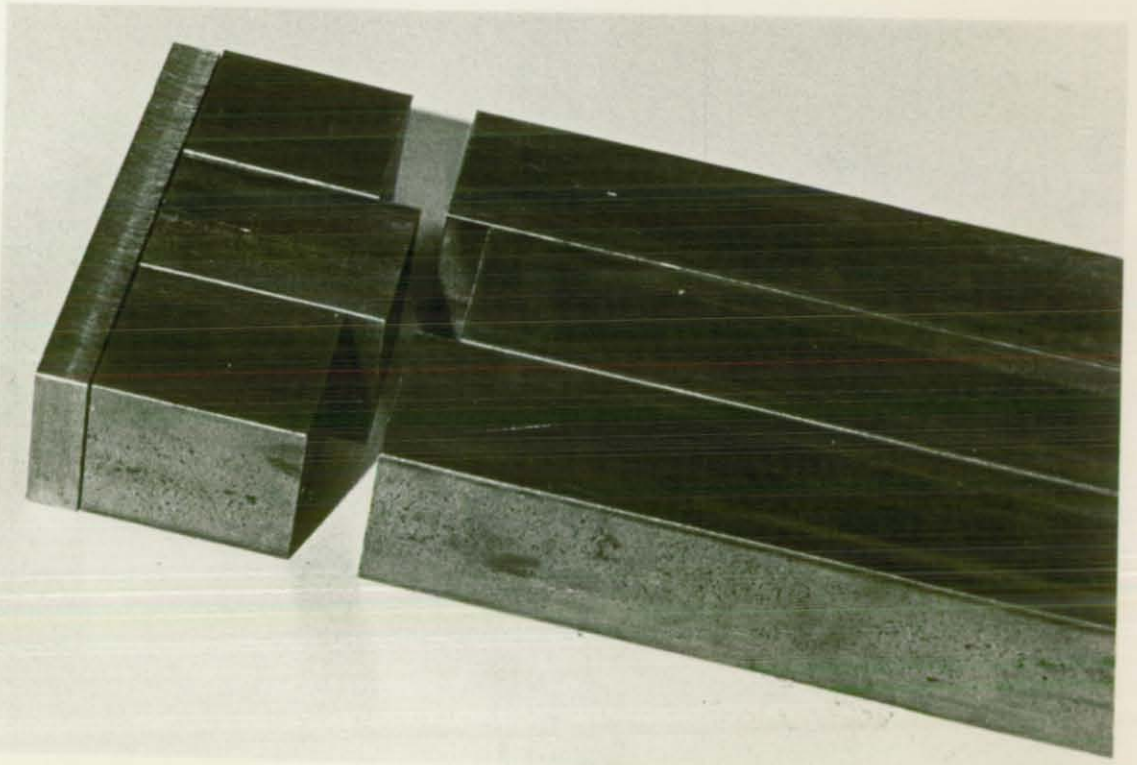

(b) Closed Die Arrangement





**0.46**

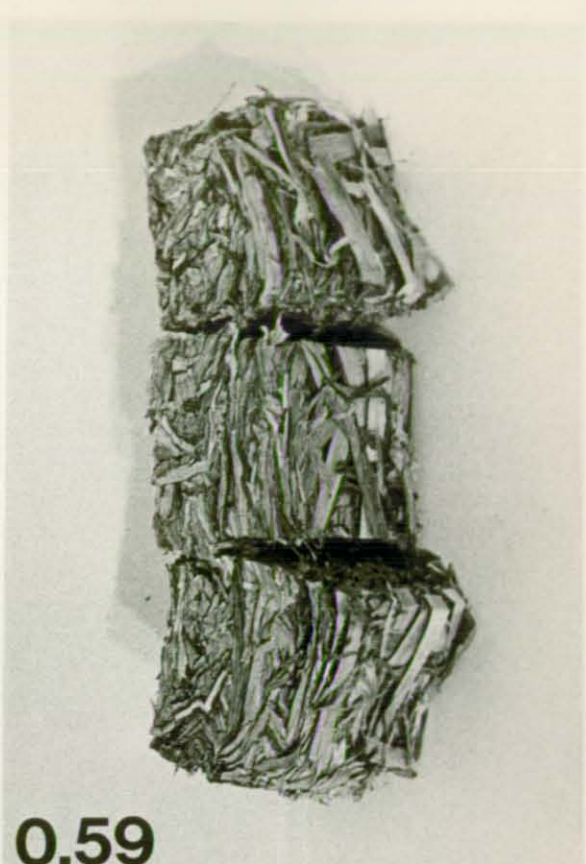

**0.59**



**0.65**

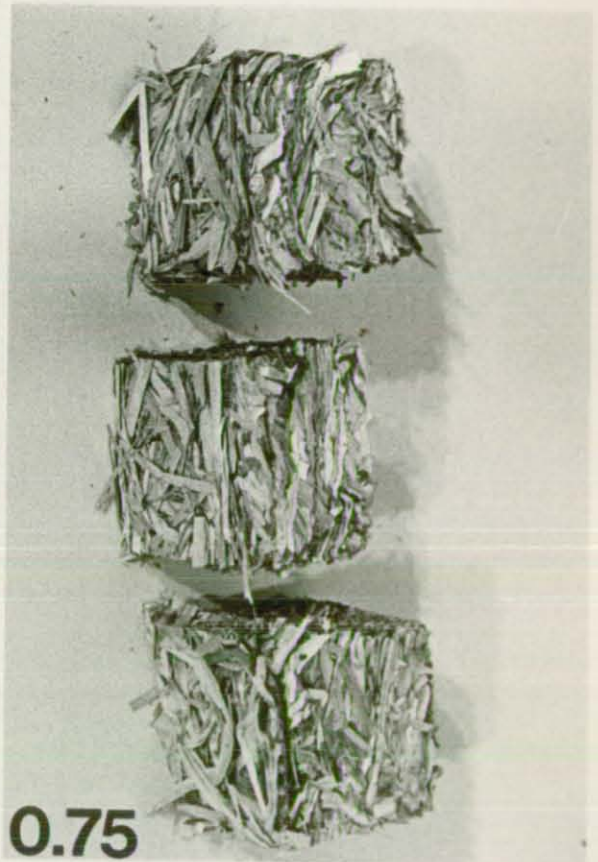

**0.75**

PLATE 8.2 SAMPLES FROM TESTS AT VARIOUS STEP RATIOS (s/h)

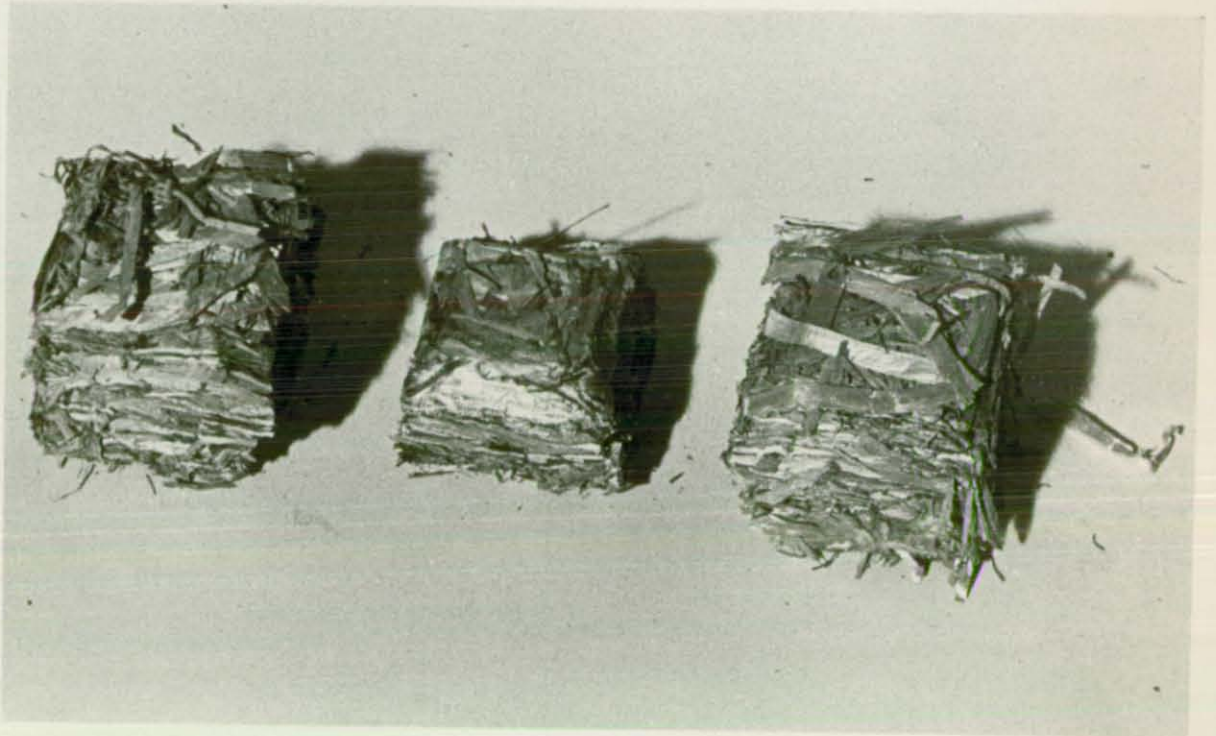
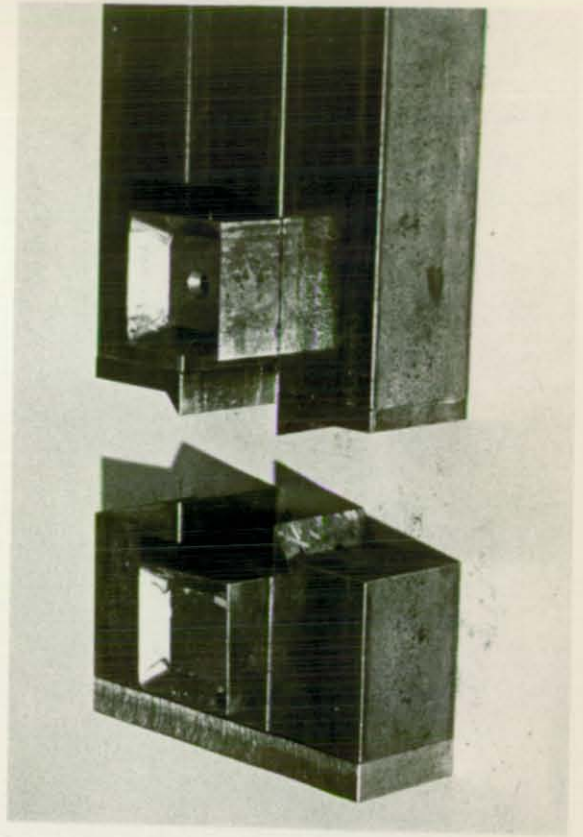
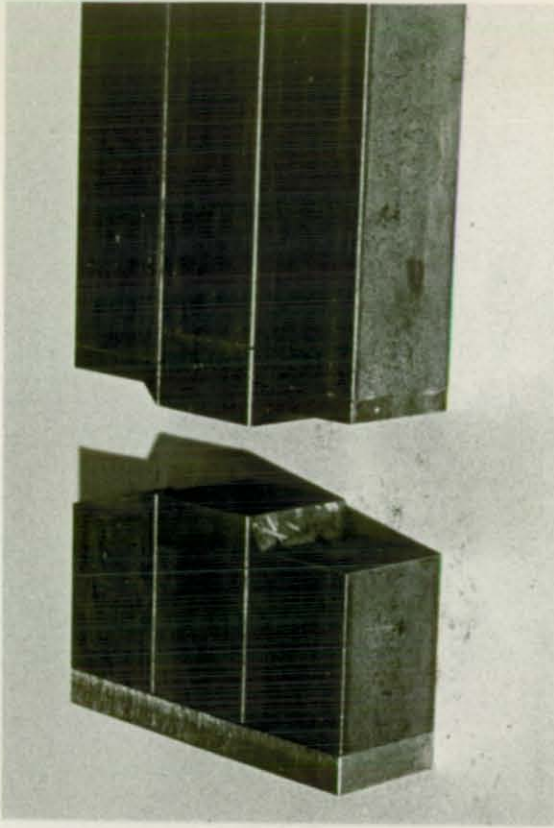

PLATE 8.3 DIE ARRANGEMENT AND RESULT FOR CONFIGURATION 'F'

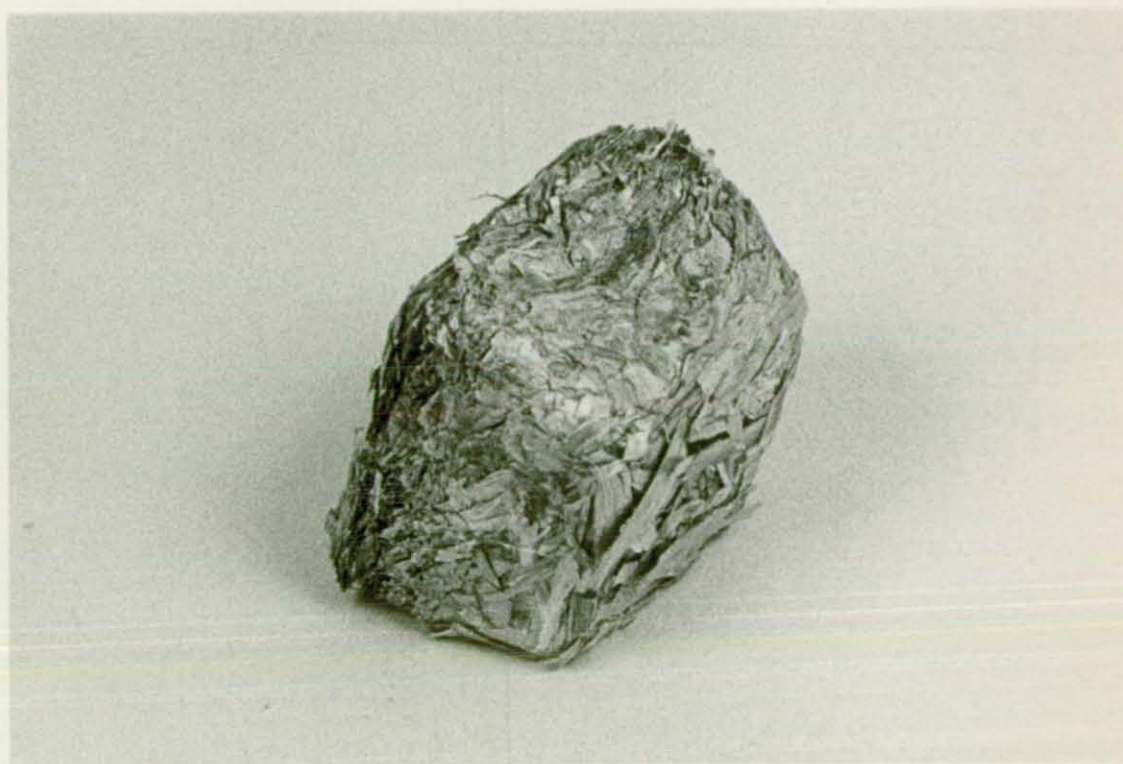
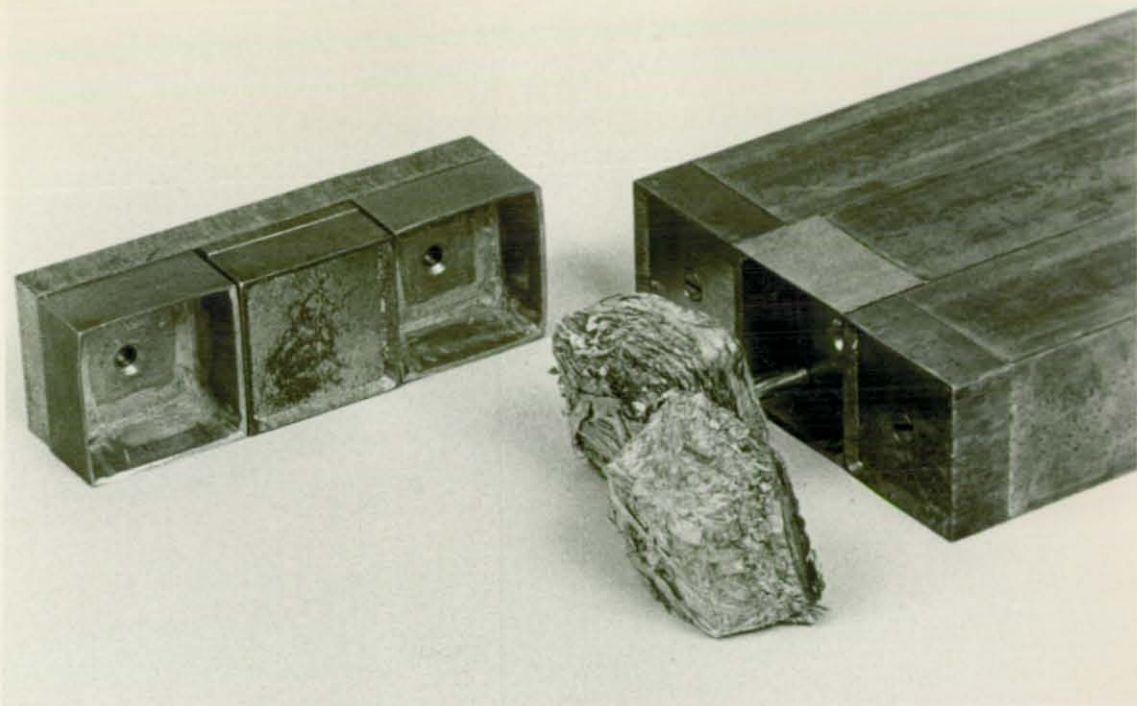

PLATE 8.4 DIE ARRANGEMENT 'G' AND RESULTING BRIQUETTES

## 9. RESEARCH INTO THE EFFECTS OF MOISTURE

This section of the research project extends the investigation into the behaviour of wheat straw of various moisture contents. The laboratory tests were again intended to be representative of the proposed disc type field compactor. The only major deviation from the intended working environment was the considerably slower rate of compaction of the hydraulic press but this parameter would be the subject of a further investigation (Chapter 10).

Earlier researchers (see Discussion Section 9.3) had found both upper and lower limits to the moisture content which formed acceptable straw briquettes but all had previously used cylindrical dies. The tests, detailed here, compare the joint effects of die shape and moisture content upon the density and durability of samples formed using the same maximum pressure. Comparisons are also made between 'bulk' and 'unit' density and the integrity of alternative methods for quantifying the results are assessed. The results are discussed and compared with available published information and with results obtained from similar tests conducted on commercially available straw fuel products.

### 9.1 EXPERIMENTAL METHODS AND PROCEDURES

The experimental method and apparatus used for forming briquettes from samples of wheat straw was similar to that described in the previous chapter. Samples were removed from the dies as quickly as possible after forming and individually weighed. Their relaxed height was measured after a period of free relaxation of at least 30 minutes.

In all tests the maximum forming pressure and the charge mass were held at nominally 50 MN/m<sup>2</sup> and 63 grammes respectively.

#### 9.1.1 Methods used for quantitative Measurement

Moisture content was determined by comparing the weight of a wet straw sample with that of the same sample dried in a ventilated oven for 24 hours at 103°C - a similar method to that prescribed by A.S.A.E. S358.1 "Moisture Measurement - forages". The moisture content was expressed as a percentage of the weight of the original wet sample (w.b. percent). Samples of baled wheat straw, which had been stored under different conditions at several farms, were obtained, giving an intrinsic spread of moisture contents. It was, however, found necessary to artificially dry and artificially wet samples at the extremes of moisture content to provide a broad spectrum of results. Drying was achieved by placing the loose sample in the oven for two hours before formation. Wetting was carried out by agitating the sample in a large polythene container after fine-spraying with a measured quantity of water. Between tests all samples of loose straw and of formed briquettes were kept in sealed polythene bags to help maintain existing moisture levels for an extended period. Drying for the moisture tests was normally carried out as soon as the durability checks were complete and the results were taken the following day. The moisture content, listed in the results tables, refers to the prevailing conditions at the time the briquettes were formed. In some cases, to reduce the considerable number of individual tests, briquettes formed in previous experiments were used where a considerable time had elapsed between manufacture and testing; in these cases the moisture content was re-checked and this has been noted.

Durability of formed briquettes was measured by the method described in A.S.A.E. S269.3 - Definitions and methods for determining density, durability and moisture content. Again this method was originally devised for pelletised forage crops but it could be usefully extended and adapted to straw briquettes. The method entailed the construction of a suitable electrically driven tumble test rig to meet the specific requirements. The durability for a ten sample batch was expressed as a percentage of the original wafer mass remaining after tumbling in the prescribed polygonal steel mesh cage at 13 r.p.m. for three minutes. Plate 9.1 shows the equipment.

The methods used for determining unit, and bulk density were consistent with those employed in previous work at L.U.T. and are described below. The procedures, more normally applied to forage produce, given in A.S.A.E. S269.3 were more applicable to small, mass produced pellets or wafers and were thought to be unnecessarily complicated and time consuming to give adequate comparative results for the laboratory work. A single bulk density test to comply with this standard, for instance, would have required more than three hundred briquettes to be manufactured.

The unit density of briquettes was expressed in three different ways:

- i. The minimum closed height of the dies was recorded during formation and the compressed density (wet),  $\rho_c$ , calculated from the known cavity volume and recorded mass.
- ii. The relaxed density (wet),  $\rho_r$ , was calculated by substituting the height of the briquette measured after relaxation. this assumes that relaxation in directions other than the loading direction is negligible.

iii. The dry relaxed density,  $\rho_d$ , was calculated by the subtraction of the moisture content from the relaxed (wet) density. This is the most accurate measure of the quantity of combustible material in a given package size. However, it is known<sup>(50)</sup> that straw with a small moisture content (2% - 5%) burns with optimum efficiency.

The bulk density of briquettes was established by three different methods:

- i. The method described by A.S.A.E. 269.3 was approximated using a cylindrical container which measured 135 mm diameter and 160 mm high. This container was much smaller than that specified but was the largest which the available sample of briquettes would fill. The bulk density figures obtained by this method are likely to be somewhat lower than could be expected in practice due to the exaggerated end effects caused by large briquettes in a relatively small container.
- ii. By repeated tests using thirteen briquettes randomly encapsulated together in a strong polythene bag. The polythene was formed to the approximate shape of the bundle by sucking out the surrounding air. The mass of the sample was recorded and the volume measured by immersion in a tank of water and noting the volume of water displaced. The results of this experiment are likely to be quite accurate as end effects are eliminated.
- iii. By a calculation of the number of briquettes of known shape and size which would fill a cylindrical container 381 mm (15") in diameter and 483 mm (19") high (that required by the A.S.A.E. bulk density test).

The relationship between bulk and unit density is compared (Tables

9.2.2a and 9.2.2b) and the validity of the different methods is discussed.

### 9.1.2 Experimental Details and Die Configurations

The basic experiment undertaken in this investigation employed stepped dies of style 'G' as derived from the previous work but, as the work progressed some unexpected results were obtained. It, therefore, became evident that further experimentation was required, using various different die configurations, to supplement the results and explain the findings.

#### Supplementary Experiments

1. Two representative samples of more than ten briquettes were made from straw of different moisture content using rectangular, square edged, stepped dies (style 'A'). These were tumble tested for direct comparison with the shaped stepped dies of the basic experiment. The results are presented at the foot of table 9.2.1a
2. A batch of ten briquettes was made in a single, closed die, shaped according to the recommendations of chapter 8. This sample was tumble tested for comparison with the briquettes of similar shape made with the stepped dies of the basic experiment. The result is presented in Table 9.2.1b
3. A further durability test was conducted on a batch of ten briquettes made during the preliminary experimentation phase with a rectangular square edged closed die of 55 mm x 65 mm cross section. The samples had been stored for several months in the laboratory in a sealed polythene bag. The moisture content at



the time of the durability test was measured and the result is also presented in Table 9.2.1b.

4. A quantity of commercially available, extruded, straw briquettes (trade name "Supaglo") was purchased and tested for durability, moisture content and density. Tests were conducted using wafers separated at their cleavage as required by the A.S.A.E. standard. Tests were also performed on larger clumps of wafers but the results from these tests could be misleading because a high figure was obtained when individual wafers separated at the cleavages during the tests and had to be counted as weight lost. The results are presented in Table 9.2.1c.

5. It has been shown that another factor which could affect the density of briquettes formed in the laboratory tests is the length of time which they are subjected to the maximum pressure (Section 7.6). A simple investigation was carried out to check if holding the briquette under pressure for a period of three minutes resulted in a quantifiable improvement in durability, when compared with samples where the load was released immediately.

The result is presented in Table 9.2.1d.

## 9.2 RESULTS

### 9.2.1 Density and Durability

DIE SHAPE	MOISTURE CONTENT 'Corrected' (w.b. %)	DURABILITY RATING (%)	AVE. 'WET' RELAXED DENSITY (kg/m <sup>3</sup> )	AVE. 'DRY' RELAXED DENSITY (kg/m <sup>3</sup> )	NOTES
G	6.0	75.8	447	420	i
G	8.5	-	659	603	
G	8.7	-	650	593	
G	9.4	86.2	-	-	
G	13.0	91.4	-	-	
G	14.3	93.3	-	-	
G	15.2	88.4	614	521	ii
G	15.5	88.4	-	-	
G	15.5	96.4	670	612	iii,iv
G	15.5	93.9	670	606	iii,v
G	17.1	93.0	-	-	
G	18.4	91.0	-	-	vi
G	21.0	74.2	285	225	vi
G	23.0	-	259	199	
A	9.3	69.6	-	-	
A	15.2	74.0	-	-	

NOTES: All samples pressed to 50 MN/m<sup>2</sup>

- i Oven dried samples.
- ii Low durability recorded due to breakage of a single poorly formed briquette.
- iii Samples dried at room temperature.
- iv Moisture content at time of tumbling 8.6%.
- v Moisture content at time of tumbling 9.5%.
- vi Artificially 'wetted' samples.

Table 9.2.1a Durability/Density Results from Stepped Dies.

DIE SHAPE	MOISTURE CONTENT 'Corrected' (w.b. %)	DURABILITY RATING (%)	AVE. 'WET' RELAXED DENSITY (kg/m <sup>3</sup> )	AVE. 'DRY' RELAXED DENSITY (kg/m <sup>3</sup> )	NOTES
G	13.8	97.8	696	600	i
55x65mm	12.0-16.0	92.6	420	382	i,ii

NOTES:

- i Single enclosed die cavity.
- ii Moisture Content at time of tumbling 9.2%

Table 9.2.1b Durability/Density Results from Closed Dies.

DIE SHAPE	MOISTURE CONTENT (w.b. %)	DURABILITY RATING 'range' (%)	AVE. 'WET' RELAXED DENSITY (kg/m <sup>3</sup> )	AVE. 'DRY' RELAXED DENSITY (kg/m <sup>3</sup> )	NOTES
53mm Diameter	11.4	96.0-99.0	1050	930	i
Cylinder	11.4	95.8-97.2	1050	930	ii

- NOTES: Results are compiled from five separate tests.
- i Samples tested as delivered (various lengths).
  - ii Individual wafers separated at cleavage points.

Table 9.2.1c Durability/Density of Extruded Briquettes.

LOAD CONDITION	MOISTURE CONTENT (w.b. %)	BRIQUETTE MASS AVE. (g)	COMPRESSED DENSITY (kg/m <sup>3</sup> )	RELAXED DENSITY (kg/m <sup>3</sup> )	RELAXATION RATIO
Immediate Release of Load	14.0	55	1057	558	1.9
Max. Load held for 3 minutes	14.0	61	1117	621	1.8

NOTES: Each result is the average of 3 samples.

Table 9.2.1d Comparison of densities for samples held under load.

### 9.2.2 The Relationship between Unit Density and Bulk Density

METHOD	AVERAGE UNIT DENSITY (kg/m <sup>3</sup> )	BULK DENSITY 'wet' (kg/m <sup>3</sup> )	BULK DENSITY 'dry' (kg/m <sup>3</sup> )	BULK/UNIT DENSITY RATIO
Rigid Container	588	342	314	0.58
Flexible Container	588	423	390	0.72

NOTE: Tests were conducted with briquettes made from straw of 12-16% M.C. allowed to dry to 8% M.C. during storage.

Table 9.2.2a Comparison of Bulk and Unit Density

RELAXED DENSITY (kg/m <sup>3</sup> )	MOISTURE CONTENT (w.b..%) source; graph 9.2	BULK DENSITY (kg/m <sup>3</sup> )	BULK/UNIT DENSITY RATIO
700	10 - 14	431	.62
600	8 or 16	395	.66
500	6.5 or 18	322	.64
400	5 or 19.5	251	.63
300	21	215	.72

NOTE: Calculated bulk density for 63 g briquettes based on an estimate of the number of briquettes of known shape and size to fill a container Ø 381 mm X 483 mm high.

Table 9.2.2b Bulk Density; Theoretical Results to A.S.A.E. 269.3.

### 9.3 DISCUSSION AND ANALYSIS

O'Dogherty and Wheeler<sup>(35)</sup> found that, in general, the upper limit of moisture content for the formation of coherent briquettes was 25% w.b. When the applied pressure was limited to  $50 \text{ MN/m}^2$ , they found that the practical value was reduced to 19.5% w.b. They suggested 10% w.b. as a reasonable lower limit and 15% w.b. as the optimum. With straw of optimum moisture content it was possible to achieve A.S.A.E. durability ratings of almost 98% in their closed cylindrical dies. The dry relaxed density of briquettes was found to increase with decreasing moisture content and at 15% w.b., using a 50 mm diameter die, a relaxed density of about  $400 \text{ kg/m}^3$  could be achieved. The specific energy requirement for forming such briquettes was found to be approximately 20 MJ/tonne and did not vary significantly with different moisture contents.

In contrast, Chaplin had conducted moisture related tests on chopped straw using an extrusion machine<sup>(27)</sup>. He varied the moisture content between 9% and 15% w.b. and succeeded in producing coherent briquettes of between 58% and 86% durability but was not able to identify any particular trend for this variation. He also produced a scatter of results comparing dry relaxed density with moisture content; his results varying between 340 and  $460 \text{ kg/m}^3$ . The specific energy used in this process was much higher at about 140 MJ/tonne. Further to this, he showed that significant improvements could be made with the extrusion process by using ground straw and introducing a binding agent.

During the investigations, described here, it was found that very small changes in experimental method could produce disproportionately large

variations in the final results. In order to meet A.S.A.E. requirements and achieve a single result for durability it was necessary to make at least twelve briquettes. If the amount of straw placed in the cavities was underweight then the dies would not fully close giving false readings for the applied pressure and producing poorly constructed briquettes. A large quantity, about 0.75 kg, of straw was used for each durability check, so it was possible that there could be some considerable variation in moisture content throughout the sample which led to the production of an occasional 'wet' briquette. The breakage of a single, poorly formed briquette in an otherwise acceptable sample of ten, would reduce the tumble test durability rating by up to 10%. For these reasons the results had to be analysed with great care. Suspect results (15.5 MC/88.4% Durability and 15.2 MC/88.4% Durability) were omitted from graph 9.1 in order to create a realistic and intelligible overview. All graphs were compiled using 'Telegraf' computer curve fitting techniques.

In common with the A.F.R.C. researchers, changes in moisture content due to evaporation were detected even though briquettes were stored in polythene. The results have been corrected to account for this where possible.

Evaluation of the results illustrated the disadvantage of a 'stepped die' system when compared to a 'closed die' arrangement with regard to wafer durability. This reaffirmed the earlier findings that the bonding of straw briquettes under simple compression is principally caused by the mechanical interlinking of many individual fibres which are permanently deformed in a randomly disorganised mass. Logically, when this mass is sheared or separated in some way, then many of these outer fibres will inevitably be severed rather than folded back inside

the package, which must lead to reduced durability of the product. It was inevitable then, that the closed cylindrical die shape chosen for the A.F.R.C. tests should yield comparatively higher durability ratings, because that shape presented no corners on its side surfaces and was only likely to suffer substantial fibre losses, in tumbling, from the top and bottom faces. The closed die test on ten briquettes, using die shape 'G' which is a development of a basically rectangular profile, produced comparable durability results and showed that many of the corner losses, inevitable in the rectangular shape, had been eliminated by careful design of the cavity.

Baled wheat straw, stored in farms under a variety of conditions, was found to have a 'natural' moisture content of the order of 12% - 16% w.b. Within this range the 'dry' relaxed density and durability ratings for briquettes formed at  $50 \text{ MN/m}^2$  in stepped die shape 'G' normally exceeded  $500 \text{ kg/m}^3$  and 91% respectively. For maximum durability the optimum moisture content was found to be about 15.5% w.b. irrespective of die shape. Moisture contents outside the range 9% - 19% resulted in briquettes with durability ratings of less than 85% and these would be considered unacceptable for practical purposes. Test results indicated that storage of briquettes in dry conditions for long periods did not greatly affect their durability, despite their reduced moisture content resulting from evaporation.

The die shape optimisation (Chapter 8) resulted in a significant 28% improvement in durability rating over samples made in rectangular, square edged, stepped dies. It must be noted, however, that there was a tendency for briquettes to fail in a notably different manner: whereas rough handling of rectangular packages would result in a general disintegration of the corners and outer faces, the new type of



briquettes quite frequently suffered a clean separation of the upper and lower sections at the widest point with the separated parts remaining substantially intact. A.S.A.E. S269.3 specifies that all particles which weigh more than 20 per cent of the original average wafer mass shall be counted as Wafer Size Material (WSM) so, in many cases, both parts of a split briquette could contribute to the wafer mass with only a relatively small proportion being lost as fines. The size distribution index was not recorded at this stage.

There was a marked reduction in durability between briquettes formed in stepped dies and those made in otherwise similar closed dies; it is unlikely that A.S.A.E. durability ratings of greater than 95% would be possible using the stepped die arrangement of a disc compactor, unless a major change was made in the initial design specification. If the load could be held for a short period in the fully compressed condition, for instance, then a small improvement in quality would be achieved.

The overall bulk density of briquettes made with the stepped die system, is likely to be between 65% - 70% of their unit density for transport or long-term storage considerations and the most appropriate method of measuring this in the laboratory was thought to be the flexible container method (Clause 9.1.1 method [ii]).

Little correlation was found between density and durability. Alterations in the die shape and/or the method of forming could result in a large changes in durability while maintaining the same relaxed density.

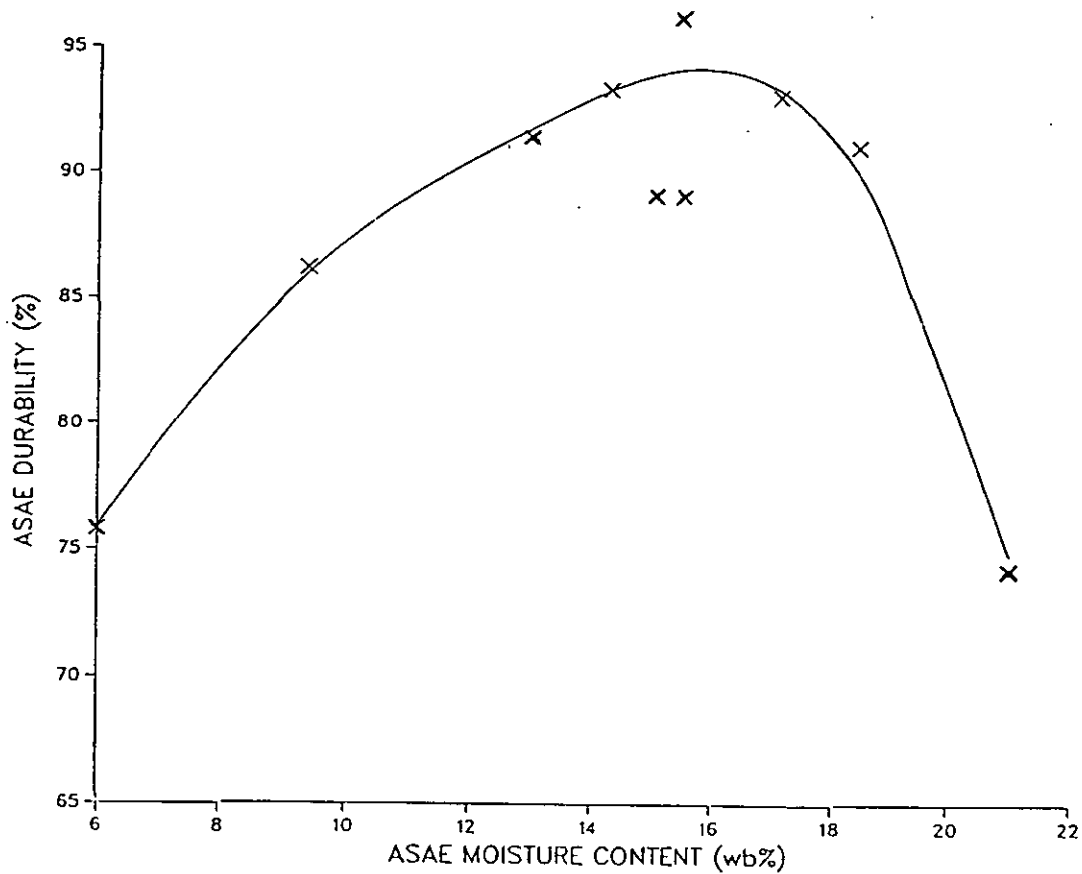

Graph 9.1 Graph of Moisture Content against Durability Rating for type 'G' stepped dies.

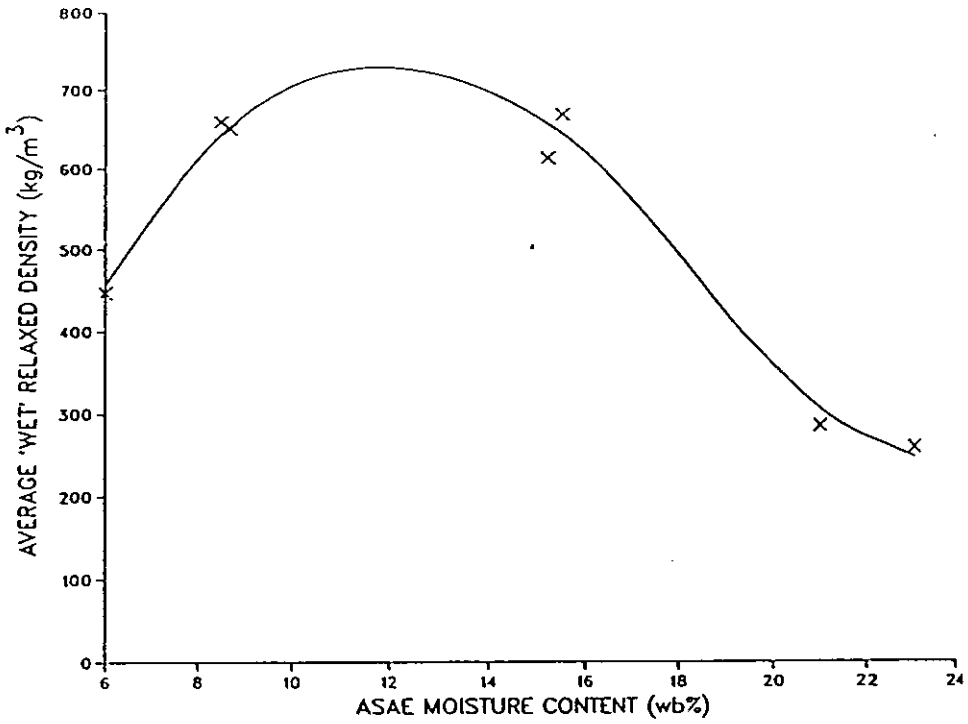

Graph 9.2 Graph of 'wet' Relaxed Density (Average of at least three briquettes) against Moisture Content using type 'G' dies.

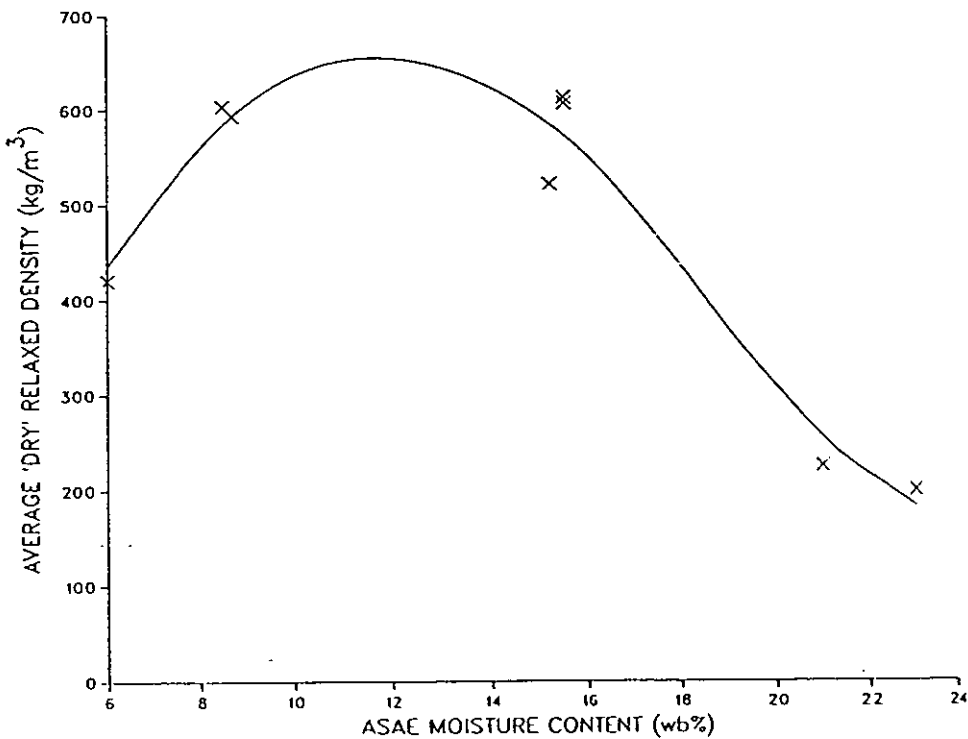

Graph 9.3 Graph of 'dry' Relaxed Density (Average of at least three briquettes) against Moisture Content - type 'G' dies.

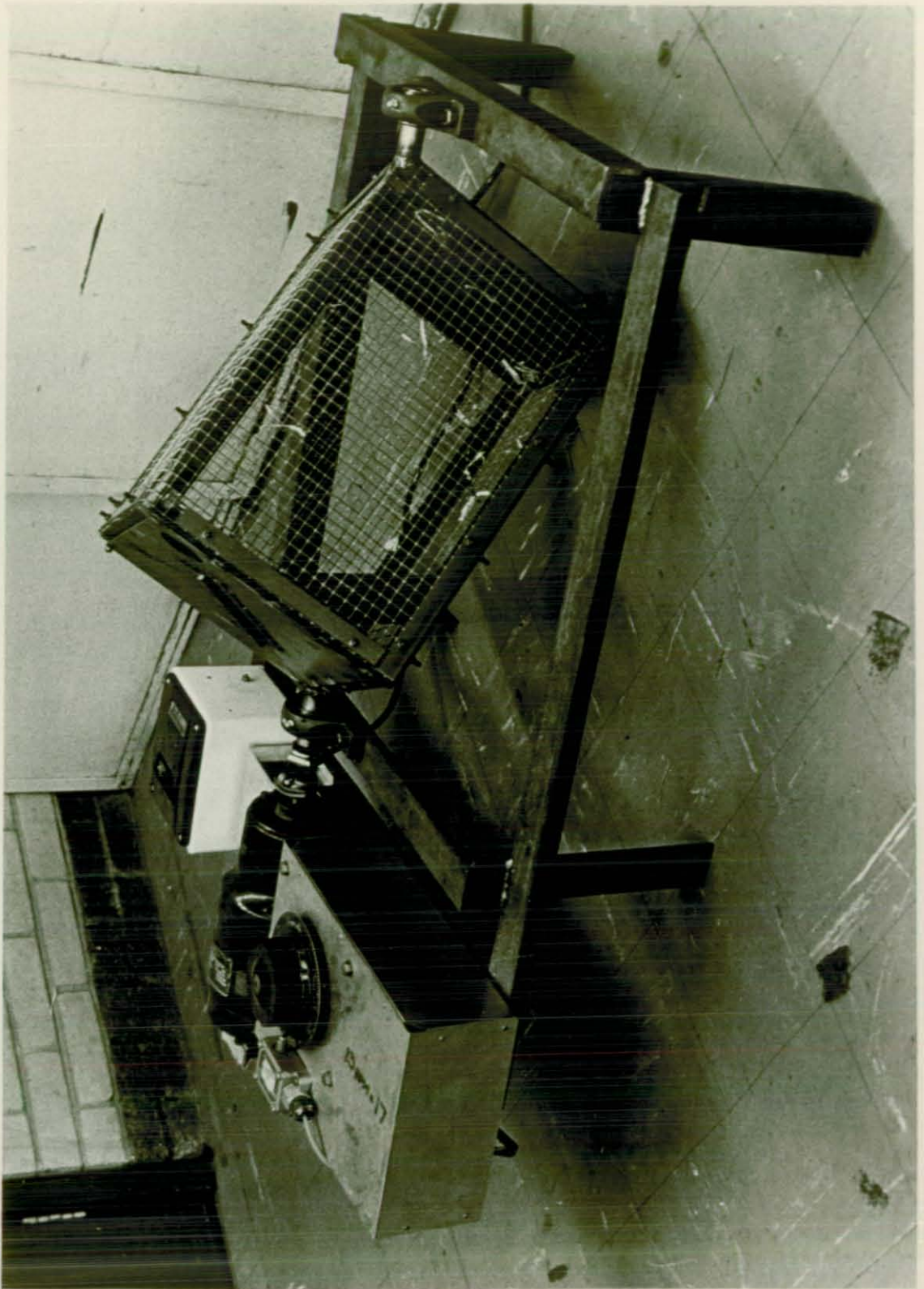

PLATE 9.1 DURABILITY TEST RIG

## 10. RESEARCH INTO THE EFFECTS OF HIGH VELOCITY LOADING

At an early stage in the project, concern was expressed that insufficient data was available on the formation of briquettes at compaction velocities which would equate to the economic production rate. That the process of straw fibre compaction is affected by time related functions is undoubted; this has been shown in tests of briquette relaxation as well as those involving dwell or retention of the load. It would, therefore, be reasonable to suppose that the quality of briquettes would be altered by significant changes in the duration and form of the compression cycle. The following investigations were initiated so that compaction tests could be conducted at speeds likely to be required in a field machine. No evidence could be found of prior results using straw.

The relatively minor adjustments to stroke rate available on standard laboratory testing machines gave no useful results and the practical difficulties in accurately representing the briquette formation rate should not be underestimated. A rate which equates to producing nearly forty briquettes per second would be required, where the cyclic load to form three briquettes would be equivalent to approximately forty tonnes.

All available data referred to either slow or 'static' laboratory tests. However, very fast, 'impact' conditions have also received some attention (see below).

### 10.1 IMPACT LOADS

Over a period of three years, undergraduates at Loughborough undertook

projects, supervised by the Author and Professor Vitols, to investigate the possibility of producing straw briquettes at high compaction rates. The projects were of a generalised nature and were not specifically related to a particular velocity or briquette shape or size.

During the first year, Roberts<sup>(51)</sup> designed and constructed a simple test rig which consisted basically of a tube, approximately 10m long, attached to the outside of the Mechanical Engineering building, with a single rectangular closed die-set fixed below it at ground level. A large steel weight (27 kg) was dropped down the tube onto a plunger which, in turn, acted on straw pre-loaded into the die. The briquettes from these tests were not of a similar quality to those produced by mainstream activity and gave further rise to fears that high speed compaction would fail. Roberts suggested that about twice as much energy would be needed at high speed as had been determined by the 'static' laboratory tests, although he acknowledged several fundamental deficiencies in his experimental methods and equipment.

Colley<sup>(52)</sup> continued the project during the following year. He made minor improvements to the rig and added strain-gauge instrumentation to the plunger in an attempt to fully evaluate the disposition of the kinetic energy in the drop weight after impact. He proposed a useful Spring Mass model for the time-related behaviour of the straw package and found experimentally that the density of briquettes formed on impact was approximately halved in comparison with slow speed compaction. He too conceded that further instrumentation would be needed to completely explain how the impact energy was dissipated and he admitted that the unreliability of the cumbersome experimental method gave little confidence in his results.

In a final attempt to confirm these findings, Gilbert<sup>(53)</sup> fitted an accelerometer to the plunger. He too found great difficulty in returning consistent results during unfavourable weather conditions, so this line of investigation was eventually dropped. These experiments had, however, provided the first information relating to high speed compaction of straw but the velocities used were much too high to draw direct comparisons with the proposed processing machine and the results were too unreliable to be of direct application in optimising the design.

Previously, Chancellor<sup>(32)</sup> had experimented with hay, forming wafers under impact conditions using a pneumatic test rig, and concluded that impact loading was less efficient than slow or static loading. He found that both wafer density and durability were noticeably affected and, furthermore, could not be significantly improved by increasing the magnitude of the impact load.

In common with the undergraduate researchers' equipment, the type of rig Chancellor used was not capable of producing controlled variable speeds of the same order as a disc compactor, neither could it generate the higher pressures required for making briquettes from straw. A further incompatibility was that the cyclic velocity profile which would be generated by rotating elements could not be faithfully represented.

## 10.2 DESIGN OF LABORATORY EQUIPMENT TO REPRESENT FULL SPEED FIELD CONDITIONS

It was clear that a separate study would be required to research into this specific problem; the remainder of the chapter describes trials

which were conducted, using a purpose designed and built test rig fitted to an modified experimental crank press, hired on an external sub-contract. As stated in Clause 6.5.1, the sponsoring company had initially made the commercial decision to adopt the slower converging Conical Disc Compactor scheme rather than risk the more rapid loading of the Radial Disc system also proposed; consequently, the laboratory trials were destined to bear direct comparison with the former type of field compactor.

The experimental press could be adjusted to operate only marginally more slowly than the calculated speed of the proposed compactor. Rather surprisingly, comparison with results obtained using very low speed compaction showed only small differences in the quality of briquettes and the energy consumed in their formation. A slightly larger maximum force was recorded, however, to give the equivalent compressed density in the high speed tests. The investigation did suggest, however, that tests, carried out at low speed, could be accepted as reasonably representative of the full production rate.

At first, briquette quality was not completely satisfactory, particularly in the region of the die split. Some minor modifications to die shape were tried, but did not show any significant improvement. The investigation then led to a further evolution of the die shape and tests showed that substantial improvements had been made.

#### 10.2.1 The Search for a suitable Power Source

Assuming that it would be impracticable and undesirable to construct a complete powered rig in the University laboratory and that this would, in any case, be little less time consuming, expensive or difficult to



work with than a full scale prototype itself, some sort of high velocity press would be required to apply the load. The press would need to provide sufficient capacity to compact the straw to  $50 \text{ MN/m}^2$  at controllable velocities commensurate with that of the proposed field compactor. The machine would also need a stroke length greater than 60 mm and sufficient working space or 'daylight' to incorporate a substantial test rig. Safe working access for the requisite instrumentation would also be a basic requirement.

Various companies, research establishments, manufacturers and distributors of mechanical presses were approached with a view to locating a press that was readily accessible and would meet the required specification.

All the available machines in the various Engineering Departments on campus were surveyed, the most promising being a high speed broaching machine which had, itself been the subject of an earlier postgraduate research project in the Department of Manufacturing Engineering. The machine was an adaptation of a standard hydraulic broach which had been fitted with an accumulator to increase the stroke speed. Further investigation, however, showed that the broach could not provide sufficient power to conduct the trials.

The Production Engineering Research Association offered the use of their large 300 Tonf crank press. It was established that the velocity profile of the press was similar to that of the conical disc compactor but the press had a long fixed stroke and while the cyclic speed appeared to be very fast, the velocity of the ram was found to be only one sixth of the necessary magnitude in the lower part of the stroke; the final few centimetres of displacement being of primary

importance in making direct comparison with the disc compactor concept. In addition, the maximum space between the faces of the press at the end of the stroke (daylight) was restricted to about 330 mm. Several different schemes were evaluated at length which would adapt the characteristics of the machine to suit the purpose. The most promising involved a double mechanical lever magnification system, each lever having a 3:1 ratio. Even taking advantage of the maximum 'daylight' with this arrangement, the component parts for the rig design were massive and the stress levels in the levers were calculated to be uncomfortably high. Although it was thought to be feasible, there were serious reservations regarding the safety aspects of this solution and it eventually had to be abandoned.

The machine tool distributors were helpful in supplying information on their range of presses and, in turn, enquired from their customers whether a machine might be available for contract hire. Despite these efforts, it was impossible to reach a satisfactory agreement because the presses were, generally, in continuous use. The distributors of Raster Ltd. of Germany contacted their head office and suggested that their latest model, which had a stroke rate even greater than that required, was available in the Federal Republic of Germany where a contract would be welcomed, but this idea could not be pursued because of likely travelling costs.

Finally, and somewhat ironically, after much research and communication, a suitable press was located very close at hand within the Production Engineering Department of Nottingham Polytechnic (formerly Trent Polytechnic). The mechanical crank press by J Rhodes and Son could operate quite close to the required specification although the maximum velocity reached only 90 per cent of the

requirement. The press had been acquired by the Polytechnic in 1972 and modified to fulfil a research contract concerning the deep-drawing of sheet metals. Since the completion of that project and, in particular, following the retirement of its principal investigator, the press has been used only infrequently.

The press offered a useful range of adjustments and was already fitted with force and displacement measuring equipment. The force transducer (a strain gauge type by S.E. Labs) was mounted in one of the main vertical support pillars and therefore measured the tensile reaction to the force exerted on the ram. It carried a recent calibration certificate. The displacement transducer, an inductive type, had direct mechanical connection to the ram. These transducers afforded a graphical read-out of load against displacement when connected via an oscillator to an x-y pen-plotter. Calibration was provided by a parallel galvanometer in the case of the load and by direct measurement in the case of displacement. Plate 10.1 shows the equipment.

#### Press Details

Overall Height	13' - 0"
Overall Width	7' - 3"
Overall Depth	6' - 6"
Flywheel Diameter (i) Primary	50"
(ii) Secondary	40"
Maximum load capacity	100 Tonf
Stroke (adjustable)	1"-6"
Stroke rate (single cycle possible)	30-88 s/min (verified)
Ram height adjustment	6"
Maximum shut height (above bed)	15"
Bed plate dimensions	24" x 30"

Figure 10.2.1a shows a comparison of the velocity profile of the Rhodes Press, set to maximum cycle speed (88 strokes/min) and maximum stroke (6"), with the die closure velocity of the intended prototype conical disc compactor over 180 degrees of rotation. It can be seen that, at the starting position which corresponds to the pre-compacted in-feed position of the straw to the discs (nominal separation 80 mm) the Rhodes press achieves over 90% of the disc closure velocity. As the straw height is reduced towards the nip point, the press velocity profile becomes almost identical to that of the discs. The small deviation was deemed to be acceptable for the tests.

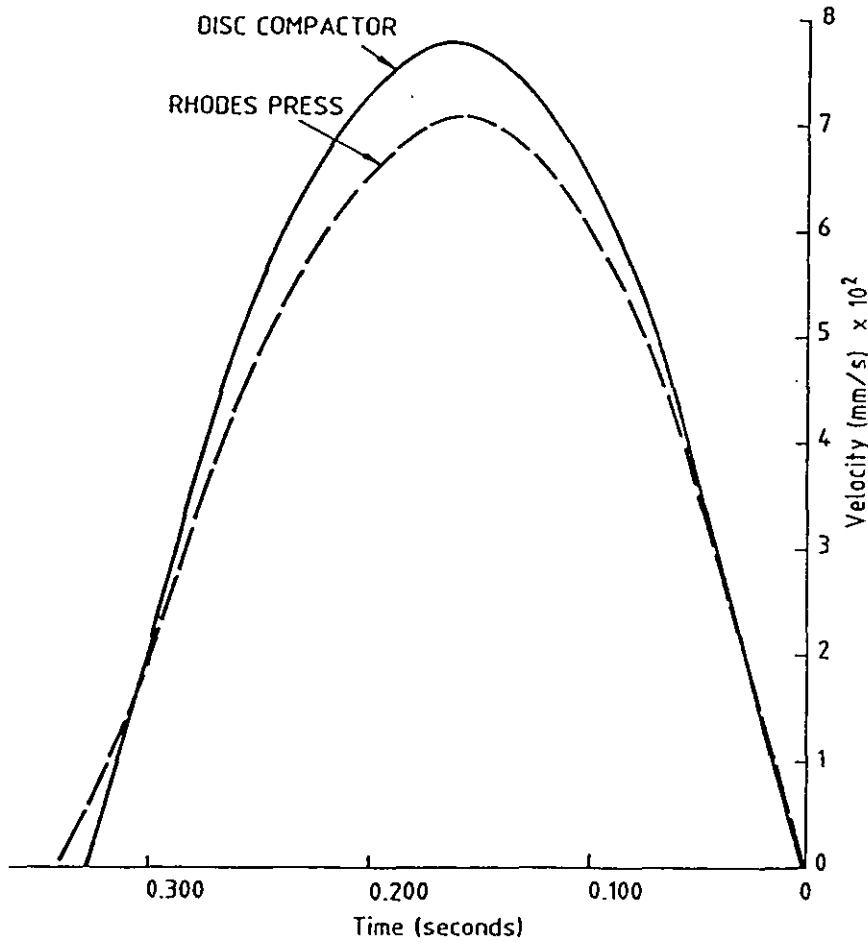

Figure 10.2.1a Comparison of Theoretical Velocity Profiles.

Negotiations with the Polytechnic secured a contractual arrangement which allowed use of the press on an hourly basis subject to a member of their technical staff being present. Testing was restricted to times outside those when the other machines in the laboratory were in use by undergraduates.

#### 10.2.2 Design of a Test Rig to suit the High Speed Press

In many ways the test rig would resemble the equipment previously used at low speed having three dies in line, with alternate deep and shallow pockets and shear surfaces at either end for the centre briquette. The main differences incorporated into the new rig would be:

- (i) Additional strength in the sidewalls.
- (ii) Base fittings to allow rapid fitting and withdrawal from the press and provide necessary central location.
- (iii) Die clearances designed such that the two die halves could overlap by a small amount in an attempt to eliminate the previously identified weak region at the abutment of the two die halves.
- (iv) A separate apparatus to pre-compact the charge into the main rig.

The shape and dimensions of the cavities used for the first two test series were a logical development of the type previously referred to as style 'G' and will, for convenience, be known as type 'H'. In later experiments, as a direct result of knowledge gained during the trials, further refinements were made to the cavity shape and details

of the resulting type 'I' die appear at the appropriate section (10.4).

Each die was made to a nominal 50 mm square cross section, 10 degree slopes on all sides for the deep ends and 45 degree chamfers of 3 mm depths for the shallow ends. In addition lateral clearances of 0.75 mm permitted overlapping of the upper parallel section of the dies up to a maximum of 6 mm. The depth of the deep cavities was calculated to suit a nominal charge of 190 grammes. The arrangement is illustrated in figure 10.2.2a.

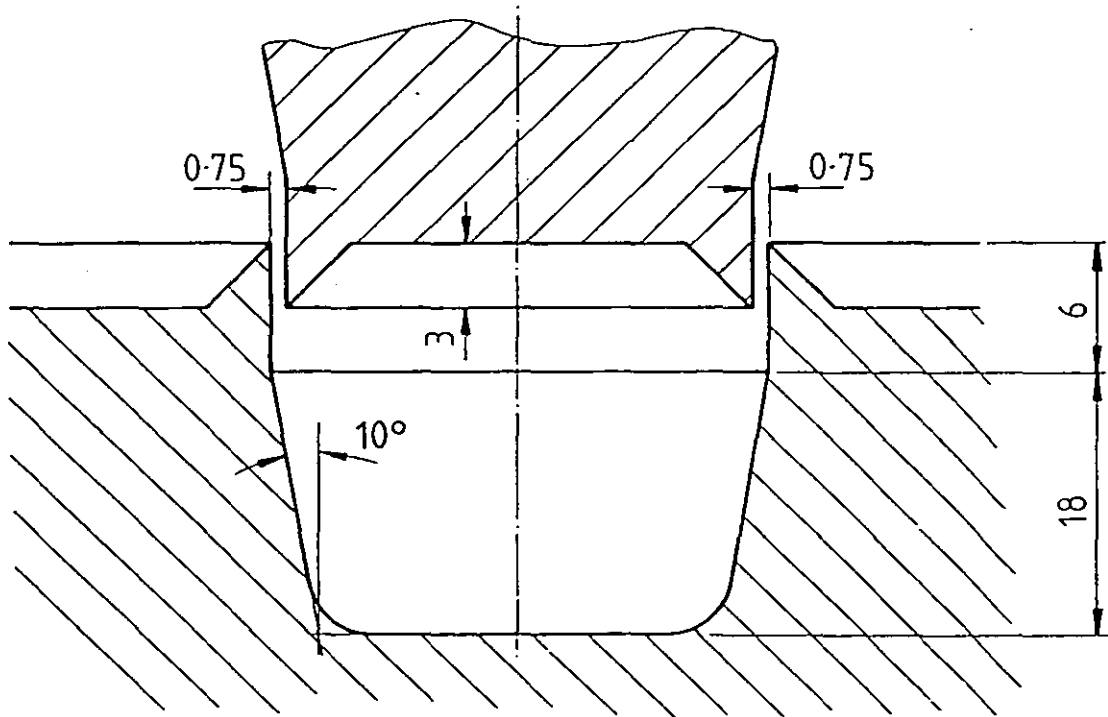

Figure 10.2.2a Test die shape 'H'.

The overlapping die arrangement created considerable complication in the test rig. The side walls of the central deep die of the punch

needed to be given additional thickness to prevent distortion and this necessitated the use of a pair of 10 mm thick sliding side-plates which filled the corresponding groove in the housing and prevented straw becoming trapped in this region. The sliding side-plates were each made in two halves such that the overall height of the rig was kept to a minimum and provision was made for the side-plates to be pressed clear through the base at the end of the stroke. The closed height of the dies was again recorded on an external height gauge incorporated in the design. Plate 10.2 shows several views of the apparatus.

A further piece of experimental equipment was built, to introduce sufficient straw into the dies and to apply a priming force comparable to that which would be provided in the field by the pre-compactor. The primed test rig was held under load by a latch-pin and, in this condition, could be introduced within the working height of the crank press. The priming force was applied with a commercially available 2 Ton hydraulic jack. Plate 10.3 shows this arrangement.

### 10.3 EXPERIMENTATION

The procedure would consist of a series of parallel static and high-speed tests in order that direct comparisons could be drawn. The familiar Denison press would first be used to load the new equipment up to and beyond the working pressure under controlled conditions as a safety check for possible mechanical failure and then to find, by experiment the charge mass which equated (on static loading) to a full-load pressure of  $50 \text{ MN/m}^2$  with the parallel sections of the dies overlapping by a nominal 3-4 mm. The hydraulically operated Denison was ideally suited for this procedure as the load reading could be

taken directly whilst the ram position was slowly and finely adjusted. In contrast, though the mechanical press allowed the closed height to be adjusted, once set there would be no further control over the level to which the load could momentarily rise throughout the cycle of the crank.

Using the Rhodes Press, the maximum speed test conditions would be: 74 mm die closure stroke in just under 0.17 seconds and the velocity profile would be approximately sinusoidal. The linear stroke-rate of the Denison under test conditions was approximately 50 mm/min.

The straw used throughout the tests was from wheat harvested and baled in the previous summer. It had been stored under cover in a Dutch Barn prior to the time when it was brought to the University. Throughout the test programme the straw had been kept indoors in large polythene sacks in an attempt to reduce the rate at which it dried out. The moisture content of three samples, taken from both formed briquettes and loose straw, was checked at the end of the primary test programme and found to be approximately 10% w.b.

#### 10.3.1 Initial Observations

Using the new die rig at slow speed provided few surprises. Generally, the visual quality of the briquettes was thought to be good but no better than those made during earlier experiments with dies that did not overlap but were otherwise similar. Unfortunately, although the fibres in contact were glazed and distorted, wiping the sheared straw down a short length of the parallel die wall did not appear to prevent the tendency of the briquette to weaken or even split laterally at the line where the two dies met.



These early tests reinforced the suggestion that further die shape modifications should be carried out in parallel with the main investigation in the hope establishing the cause of this problem and subsequently making further improvements in the durability of the briquettes.

The preliminary high speed tests were approached with some trepidation because it was feared that, under high velocity compaction, the straw sample might show a much higher resistance to compression and possibly even overload the 100 Ton press. For this reason the first tests were conducted with the press set to its slowest speed and a 'safe' shut height. At this time, the instrumentation was not connected but it was obvious that the machine was coping easily with its task, so the shut height was gradually reduced to give the required 3-4 mm overlap of the die halves. The backlash found in the mechanism of the press made it difficult to control the shut height more accurately than  $\pm 0.5$  mm.

Fresh charges of straw compressed with a single cycle of the ram at minimum periodic speed (30 strokes/min) and subsequently at maximum speed (88 strokes/min) produced briquettes of very similar appearance and were thought to be indistinguishable from those produced earlier on the Denison machine at  $50 \text{ MN/m}^2$ .

It must be noted, however, that at the early stages of the experimentation, teething problems with the rig were aggravating the tendency of the centre briquette to split laterally in two on removal from the die. In addition, although it was apparent that the 100 Ton press was working well within its capacity, no measurement had been made of the applied load.

A second series of high-speed experiments were conducted, following modification of the die rig and connection, to the press, of the load and displacement instrumentation. The rig modifications resulted in less breakage on removal of the briquettes.

The peak load recorded at a constant closure height (23 mm) was found to vary by up to  $\pm 35$  per cent for a nominally constant charge mass but the scatter of results obtained (Table 10.5.1a) did not show any direct correlation with closure velocity. Much of the variation could be attributed to the many uncontrollable experimental factors such as: the mass, the type and distribution of the fibres within the charge, the orientation of the straw, the mass distribution of the charge across the three dies, moisture variation in fibres and friction forces against the rig components. The peak load at speed, however, was almost invariably found to be higher than it had been in the equivalent static tests.

When the charge mass was deliberately varied by  $\pm 15\%$ , tests, repeated several times at maximum speed, suggested that the peak load would increase by about 60 per cent when overcharged and reduce by about 25 per cent when similarly undercharged. The overcharged briquettes were of a similar relaxed density (by calculation) to the nominal, about  $750 \text{ kg/m}^3$  but the undercharged briquettes were of reduced final density, about  $600 \text{ kg/m}^3$ . The closed height was set to 23 mm throughout, as this height had been the  $50 \text{ MN/m}^2$  (375 kN) equivalent on the static tests for the nominal charge mass; however, a similar peak force was recorded on the 15% undercharge test at 88 s/min, (Table 10.5.1b). Hence, the high speed process appeared to require a greater force for the same charge.

Although it had been possible to record results for peak load from the galvanometer, the pen traces of load against displacement were, at first, of little use. At high speed (above 45 strokes/min) the x-y traces indicated that the rate of increase of the load became less as the press neared the bottom of its stroke. This curious result was inconsistent with all previous indications and therefore, required critical examination.

### 10.3.2 Investigation into Inconsistent Load Curves

The first possible explanation for the strange loading characteristics recorded at high speed, was that the result could have been caused by the entrapment of air inside the rig. The die cavities were, therefore, modified with eight 2mm diameter release holes being drilled in each die. The result of this showed no noticeable improvement in the briquette quality and no measurable change in the energy recordings. Clearly trapped air had not caused the problem.

A second possibility was that, following initial contact between the press and the punch, there could have been momentary separation of the two, giving rise to inconsistency in the velocity profile at high speed. To check this, the press was filmed in operation using a high speed camera operating at 300 frames per second. From a replay of the film at 25 frames per sec., it could be clearly seen that this condition had not arisen. From this procedure, however, it was interesting to note that the rebound of the punch was immediate and in the region of 15 mm when the press was operated at maximum speed with a normal mass of straw in the cavity.

In a further attempt to explain the apparently consistent, but

nevertheless puzzling, shape of the load displacement curves recorded at the top speed, it was necessary to question the calibration of some of the Polytechnic's instrumentation. Firstly, the linearity of the displacement transducer was checked by direct measurement of the ram position, and found to be increasingly inaccurate towards the extremities of the stroke; a well known phenomenon with this type of instrument. Secondly a frequency response check of the pen plotter was made by recording its full displacement at various different press speeds with fixed (maximum) stroke. The recorded displacement plot was found to decrease in length with increasing speed, which suggested that the instruments were being required to work above their useful frequency response range. A second, calibrated, 200 mm long inductive displacement transducer was fitted but although its performance was known to be adequately linear over the press stroke, it still failed to give accurate readings at high speed. The output voltage of the transducer, with the ram at its lowest position, was found to drop by some 4 per cent when readings were taken at high speed. In addition, a further external check on the frequency response characteristics of the x-y recorder verified that this instrument was incapable of giving accurate results above about 1.0 Hz. (60 strokes/minute).

The likely causes of the unexpected load-displacement curves having thus been identified, the press was immediately fitted with alternative instrumentation supplied by the Investigator. A linear displacement potentiometer replaced the original inductive transducers. This gave both accurate linearity and improved frequency response. In addition, a U.V. recorder was substituted for the x-y pen plotter. The traces obtained from the machine would now be in the form of simultaneous load-time and displacement-time curves, from which load-displacement curves could only be obtained manually. The

load-displacement curve being necessary in order to calculate the work done in the test. These changes resulted in the more familiar shaped curves included in the results at the end of this chapter.

### 10.3.3 The Ejector Mechanism

It had been recognised that the quality of briquettes may be influenced, not only by the rate of compaction but also by the duration of pressure retention after compaction. Nevertheless, because of contractual time limitations the original test rig had been initially designed without an ejection mechanism.

The early compaction results were promising but, as in previous tests, all the briquettes were much better finished at the "deep end" of the die. Indeed, the "shallow end" still tended to separate away from the rest of the briquette before it could be extracted from the die set, a feature which became even more pronounced at high speed. During the experimental procedure, close observation of the compaction process revealed that the punch immediately rebounded a considerable distance owing to the resilience of the straw. It was thought that this movement could have split the briquettes against the friction of the sliding side plates. The rig was returned to the workshop and the sides of the central deep die were built up to eliminate the contact of the compacted briquettes with the plates during withdrawal, yet this change did not improve the briquettes.

A simple spring loaded ejector was also incorporated into the modified die. At first disc springs were used to load a 20 mm diameter ejector pin, yet this resulted only in a depression in the briquette but no release from the die. Extending the ejector surface to the full base

area of die with a 0.5 mm thick spring steel plate did produce a satisfactory ejector which was used subsequently in all the high and low speed tests. There was no noticeable deterioration in the quality of the deep end of briquettes; therefore it may be concluded that the better end of the sample does not result from its retention in the deep cavity for an extended period.

The design for a more positive ejector, which would release the briquette from the deep end of the die using the recoil movement of the punch was also produced at this time. All the component parts were made, but time constraints on the hourly contracted test programme prevented this from being fitted and tested.

#### 10.4 INVESTIGATION OF THE PLANE OF WEAKNESS

The problems encountered where the apparatus physically broke the briquettes after formation served to highlight the region of weakness which had previously only been identified during durability testing. The briquettes would invariably break at or near the plane coincident with the cutting edge of the shallow (chamfer) end of the die. The deep end showed straw fibres to be well interlaced at the edges whereas the shallow end displayed a less stable clean cut appearance.

Clearly, by using careful extraction methods the effects of the weak plane could be nullified. The die rig, fitted with the spring ejector in the deep cavity, was also simultaneously injected with compressed air (80 p.s.i.) through drilled entry ports into the shallow cavity such that the briquettes were not held by differential pressure at either end during the recoil. This approach eliminated the problem of briquettes being broken by die withdrawal and seemed to reduce the

tendency for splits to propagate in the finished briquettes. Later durability tests suggested, however, that the weakness plane was still present, so its cause must have been due to the die shape and the pressure distribution or to the fibre movements that the shape generated.

While the product might have been considered acceptable, even with the inherent weak plane present, in order to determine its root cause and hence, design a die to eliminate it, further factors which influenced formation were examined in detail.

#### 10.4.1 The Pressure Distribution within the Briquette

In most of the earlier tests, using a range of different die shapes, it had been observed that tapered dies produced non-uniform density briquettes. Moreover, high local pressure resulted in crushed (powdery) straw, while 'wiping' on smooth surfaces at low pressures had been found ineffective as an aid to bonding. Furthermore, an increase of direct pressure on the straw beyond  $50 \text{ MN/m}^2$  had not resulted in a proportional increase of relaxed density.

The pressure distribution within the compacted mass was not fully understood. For experimental simplicity it had normally been assumed to be constant over the entire cross section of the die, but clearly this was an over-simplification of the practical case. The subject of pressure distribution in straw under compression would, in itself, provide scope for a further substantial research project. To date, the Author has supervised three undergraduate, final year projects on related topics<sup>(54,55,56)</sup> in which relationships between lateral and longitudinal pressure have been empirically derived and related to the

straw density and friction characteristics. The Poissons Ratio for the material was found to increase with compaction density. In Purdy's work<sup>(55)</sup>, straw was pressed between two flat plates inclined at various angles to one another. He found that, even when unevenly loaded in this way at relatively low densities, the straw package reacted as a coherent mass with little evidence of internal, lateral fibre movements.

At the plane where the fault commonly occurred, the briquettes received no direct lateral pressure because the section remained constant throughout the compression cycle. Conversely, where the tri-axial pressure was greatest (the bottom of the deep die) the samples showed relatively good durability.

In an effort to shift the position of the weak plane to the edge of the briquette and nullify its effects, the cavity of the shallow die was replaced by a flat ended punch and briquettes were compacted into the deep die only. As a result of this change the briquettes had lost the small chamfer off the top edges leaving loose corners. The sheared edge became dispersed over the whole upper portion of the briquette and the change was generally thought to be retrogressive.

Secondly, a spike was fixed to the centre of the flat ended punch in order to force some lateral pressure at the large end of the briquette. The spike was made in a form of a square based pyramid of 15 mm side x 15 mm height. This resulted in a depression in the middle of the square end with some binding effect around the dib but there was no apparent changes in the fibres around the boundaries of the briquettes so presumably the movements did not propagate through the package. In an attempt to apply lateral pressure nearer to the



side walls of the die where movement of the fibres was needed, an arrangement of four spikes (similar to the above) on each flat ended punch was tried. In this case, the effects of a substantial lateral pressure were observed but the chosen apex angle of the pyramids were found to be too small, thus trapping the straw between the spikes and damaging the briquettes on withdrawal from the die. Additional tests with lower pyramids would be desirable to confirm their effect on the briquette finish. It must be remembered, however, that a rolling type of die closure, which would occur on the disc compactor, would add further complication to effective extraction and the inclusion of spikes was thought to have considerable practical disadvantages.

Reverting to the chamfered shallow die system, it was felt that a cutting, rather than a shearing action could be taking place at the centre/outer briquette interfaces which could give rise to loose raw edges with little bond strength. To demonstrate and eliminate this, the chamfered edges were rounded-off in stages. The result did not give a sufficient improvement to warrant proceeding further and the idea was disproved.

Close examination of samples showed that the weak plane was not flat as might be supposed but had a convex dome in the centre of the package towards the shallow end. It was considered that the plane could be levelled out by aiming for a more constant density throughout the briquette. The addition of 40 mm diameter X 3 mm thick nylon domed inserts in the base of the deep die reduced this curvature and a second set of inserts was made for the deep dies to build up the taper sides producing an inward curvature at the centre of each side. This method succeeded in making the plane of weakness much flatter which suggested a more even density distribution had been achieved. The fault, however still persisted.

Individually none of the above tests revealed a positive breakthrough, though it was considered that more knowledge of the bonding mechanism had been gained by the experiments and guidelines had been established which would enable proposals to be made for the next stage of development.

#### 10.4.2 Further Die Modifications to Eliminate the Weak Plane

A radical solution was now sought to improve durability or, at least, override the effects of the breakages. Die design 'I' was produced (figure 10.4.2a) based upon the following criteria:-

- Optimum quality would be reached in deep, tapered cavities.
- There would be no sharp edges.
- Tri-axial pressure would cause movements of the fibres within the package and would aid effective bonding.
- Shearing would occur when the die cavities were stepped relative to one another; however, the previously defined criterion for shearing would no longer apply as the two die halves would be allowed to overlap.

The new design was specified with cavities of approximately equal depth for each half with tapers to all side walls. With this design, clearly the extent of overlap would need to be carefully controlled as the obvious danger was that 'solid' compacted straw would become entrapped between the approaching die walls and cause mechanical failure. The intersection of the tapered sections would ensure that lateral pressure was available over the whole depth of the briquette. Only experimentation would show whether there was sufficient tri-axial pressure at the point of overlap to completely eliminate the weak plane. Should breakages still occur, however, a secondary benefit of

this die design would be that both the broken halves would still be of a commercially usable size. Extraction, in the rig, was by the admission of compressed air.

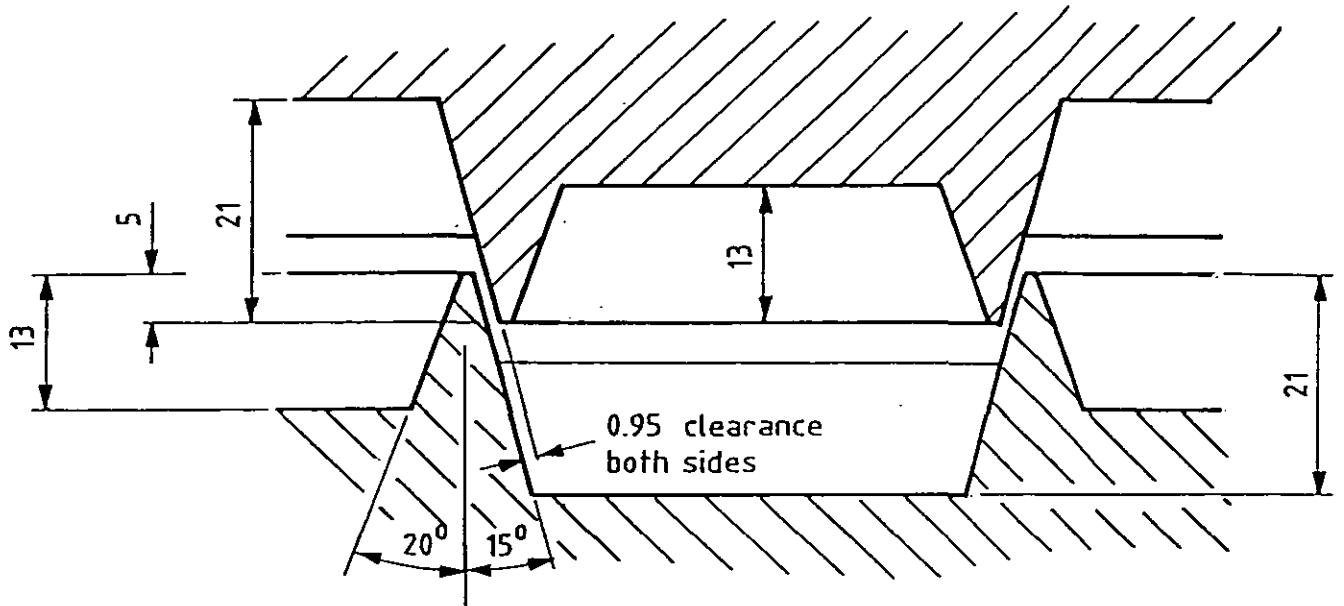

Figure 10.4.2a Die Shape 'I'

#### 10.4.3 The Influence of No-Load Inertia on the Results

The introduction, part way through the investigation, of more sensitive instrumentation (clause 10.3.2) permitted greater accuracy in the results: because the load transducer was positioned in the upright column of the press, measuring tension, the considerable cyclic inertia of the heavy ram, moving at high speed, was also detected and was included in the U-V traces. Figure 10.4.3a shows this "no-load" inertia force plotted on a magnified scale against

displacement. For each subsequent result, the cyclic inertia force was manually subtracted from the U-V plot to give only the load resisted by the straw.

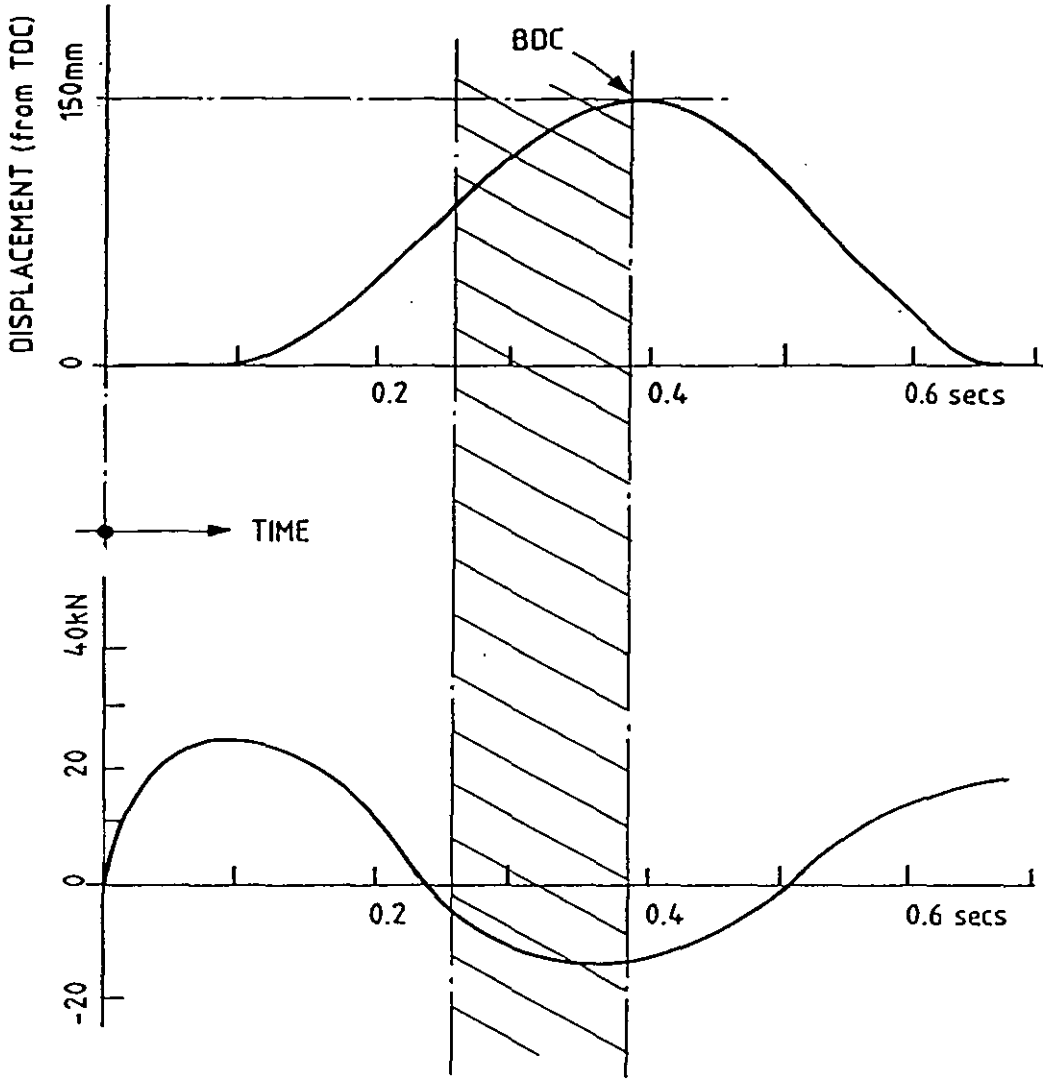

Figure 10.4.3a No-Load Inertia of the Rhodes Press at Maximum Speed.  
(The Shaded Area shows the region in which straw compression takes place).

## 10.5 RESULTS

### 10.5.1 Peak Force Variation with Velocity

* Press Speed (strokes/min)	Peak Force (kN)	** Relaxed density (kg/m <sup>3</sup> )
88	525	744
72	705	727
62	366	727
56	646	815
48	488	660
Static	375	718

Table 10.5.1a Varying Speed : Constant Charge, 190g (Die type 'H')

	Charge Mass (g)	Peak Force (kN)	** Relaxed density (kg/m <sup>3</sup> )
Undercharge	160	395	593
Nominal Charge	190	525	744
Overcharge	218	850	764

Table 10.5.1b Varying Charge: Constant Speed, 88 strokes/min\*  
(Die type 'H').

\* Single Cycle

\*\* Relaxed 'wet' density calculated from measurements taken approximately 20 minutes after forming.

### 10.5.2 Force, Displacement and Energy Consumption

Graph 10.1 shows a direct comparison of low and high speed load-displacement results for die type 'H'. The low speed tests being carried out over several minutes on the Denison machine. For the high speed tests the Rhodes press was set to single cycle at maximum speed (88 strokes/min). The results indicated that although high speed compression did not use substantially more energy overall, the peak force reached for the same closure height was consistently higher; between 10% and 30% greater. It should, however, be remembered that small experimental changes in either closure height or charge mass cause very large variations in the resisting force of the straw at high compression densities.

Graphs 10.2 and 10.3 show further load-displacement curves taken at high speed for both die types. These particular experiments consider the effect of variations in the in-feed charge upon the performance of the machine. In either instance, the charge mass was deliberately varied by  $\pm 15\%$  of the nominal. All results were extracted from U.V. traces with the Rhodes press operating at maximum speed (88 strokes/min) and corrected for the effects of ram inertia. From the graphs, the specific energy was calculated and the variation in power requirement may be compared in the corresponding tables 10.5.2a and 2b.

### 10.5.3 The Force Required to Pre-compact the Charge

Graph 10.4 shows the force required to compact straw to a density of  $253 \text{ kg/m}^3$ . Two sets of readings taken at slow speed on the Denison machine are included.

Specified Charge	OVERCHARGE	NOMINAL	UNDERCHARGE
Ave Briquette Mass (g)	72.7 (115%)	63.0 (100%)	53.7 (85%)
Closure Height (mm)	24	24	24
Peak Force (kN)	835	445	325
Mean Pressure (MPa)	111 (187%)	59.3 (100%)	43.3 (73%)
Specific Energy MJ/t	49.0 (200%)	24.4 (100%)	19.7 (84%)

Table 10.5.2a Die Type 'H'

Specified Charge	OVERCHARGE	NOMINAL	UNDERCHARGE
Ave Briquette Mass (g)	65.7 (116%)	56.7 (100%)	48.2 (85%)
Closure Height (mm)	27	27	27
Peak Force (kN)	727	393	245
Mean Pressure (MPa)	97 (149%)	52 (100%)	24 (74%)
Specific Energy MJ/t	39.9 (149%)	26.7 (100%)	19.7 (74%)

Table 10.5.2b Die Type 'I'

#### 10.5.4 Durability

##### Die Type 'H'

A durability test of ten high speed briquette samples to ASAE S269.3 gave a rating of 88 per cent. Of the 12 per cent waste which has broken away during the tumble test, 5 per cent (by weight) was fine particles of single straws whilst the remaining 7 per cent (by weight) consisted of layers of briquette which had broken away on the line where the top and bottom dies meet. None of these layers, however weighed 20 per cent of the average initial wafer mass (62.5g) and could not, therefore, be considered as "wafer size material" according to the definition in the standard.

This rating for the "high-speed" samples represents a small reduction of (3 per cent) when compared with the average durability from the slow speed tests detailed in the previous chapter.

##### Die Type 'I'

Briquettes made with this die were superior in durability to all the earlier sheared briquette types. However, the tests confirmed a similar small reduction of the rating for samples formed in the high-speed process compared with a batch, made for comparison, on the Denison.

The average Durability Rating for low-speed samples was 96 per cent and this figure fell to 93.5 per cent for the high-speed tests

#### 10.5.5 Variations in Relaxed Density with Time

The relaxation characteristics of rectangular briquettes was examined in section 7.6.



The relationship:

$$\rho = \rho_c ( (1-R)^{-bt} + R ) \quad \text{was proposed.}$$

Also that R, the ratio of the final relaxed density to the compressed density, was a function of the time held under load (zero in the case of both the static and the high speed tests).

Figure 10.5.5a illustrates the relaxation performance of both high and low speed briquettes over a period of one week from formation. The relaxed density was calculated from regular measurements and presented as a percentage of the compressed density for each sample. Little further relaxation, after one week would be expected if briquettes are stored in appropriate conditions.

The results indicate a somewhat slower initial rate of relaxation for briquettes made at low speed. The long term density of briquettes, left to relax, from both high and low speed experiments was, however, much the same. This would suggest that the proposed relationship (above) would still hold for the high speed condition and variation in the velocity of the compression stroke would effectively reduce the magnitude of the power constant 'b'.

Three bulk density tests were carried out on the final product from the high speed tests, (die 'I') using the flexible container method described in Chapter 9. The briquettes had been stored for more than two weeks and had previously been subjected to the tumble test procedure. The checks gave bulk density figures of between 320 and 340 kg/m<sup>3</sup>.

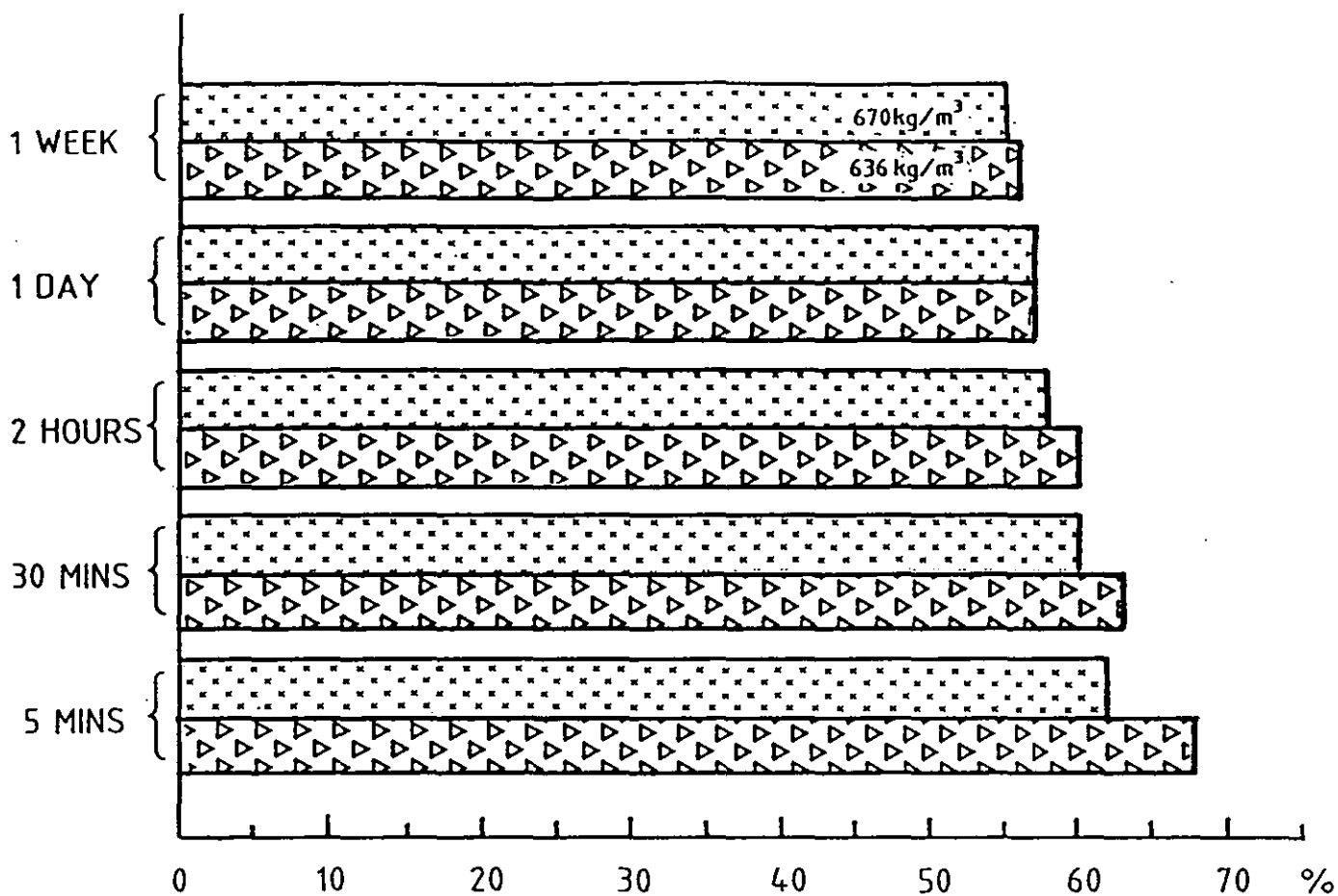

Chart showing changes in the average relaxed density (wet basis) of ten samples expressed as a percentage of the maximum density reached during compression.

KEY	TESTS	AVERAGE COMPRESSED DENSITY (100%)
•••••	HIGH-SPEED	1230 kg/m <sup>3</sup>
△△△△△	LOW-SPEED	1130 kg/m <sup>3</sup>

RELAXATION CHARACTERISTICS

Figure 10.5.5a Relaxation of Briquettes formed at High and Low Speeds.

## 10.6 CONCLUSIONS

The test conditions at maximum velocity were considered to meet the proposed field compactor work-rate specification within experimental limitations and it was possible to form acceptable briquettes at compactor speeds. The results more closely resembled the samples made under 'static' conditions than under 'impact'.

Relaxation occurred more quickly on briquettes formed at high speed but after one week the 'low speed' samples had reached approximately the same density. At this point, volume growth had virtually ceased. For all speeds up to the test maximum, the final relaxed density of briquettes, was approximately the same, around 600-650 kg/m<sup>3</sup> (by measurement).

A small increase was found in the energy requirement according to the compaction velocity. Acceptable briquettes were made at Specific Energy levels of about 25 MJ/Tonne for the high speed process. The energy level was increased, however, by around 15% when the closure height was reduced by just 1 mm as this would greatly affect the performance of the proposed machine.

The peak load at the end of the compaction stroke also varied wildly according to the experimental conditions. The tests indicated that the high speed process incurs a peak load at least 10% greater than the low speed process when all other parameters are held constant.

Varying the charge mass by 15% either side of the nominal, a minimum fluctuation which could be anticipated in practice, even assuming that a mechanism to regulate the input was incorporated in the field

machine, gave dramatic changes in both peak load and energy levels. In the final tests, the peak load varied from -36% to +85% and the power consumption varied from -26% to +49% of their respective nominal values.

Although the briquettes from die 'H' represented a substantial improvement in quality over earlier shapes an inherent weak plane was exposed. Various trial die shapes, including replacement of the shallow "male" cavity by a flat surface and the addition of fixed spikes or protrusions to the shallow end, did not completely eradicate the plane and a single tumble test conducted with ten 'high-speed' samples gave a rating of 88%, slightly down on the low speed result. A package with an approximately homogeneous density was demonstrated by adding shaped die inserts.

Otherwise well formed briquettes were found to be damaged if they were allowed to be gripped by the die cavities as the two halves were drawn apart. Positive ejection must, therefore, commence at (or slightly before) the nip point.

The evolution of die shape 'I' virtually eliminated the effects of the weak plane and has shown to offer considerable advantages in briquette durability for a further small increase in power consumption. A consistent bulk density of over  $320 \text{ kg/m}^3$  was achieved.

The density of the pre-compacted straw entering the final-stage discs should be around  $250 \text{ kg/m}^3$ . To achieve this density an average pressure of  $1.2 \text{ MN/m}^2$  was applied and held. Pre-compactor loading and performance will be examined in detail in the next chapter.

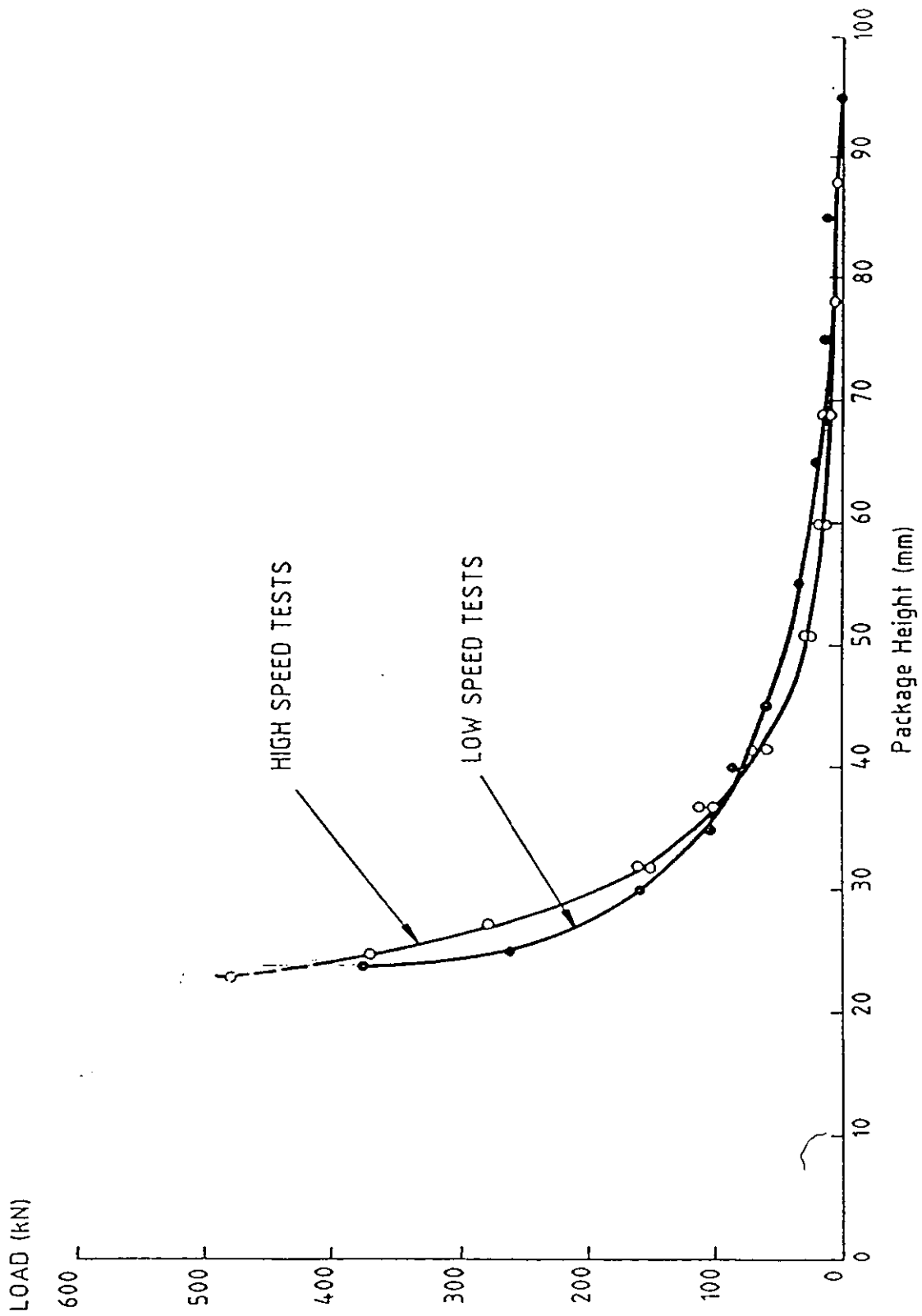

Graph 10.1 Force, Displacement and Energy Comparison for High and Low Speed Loading (die type 'H').

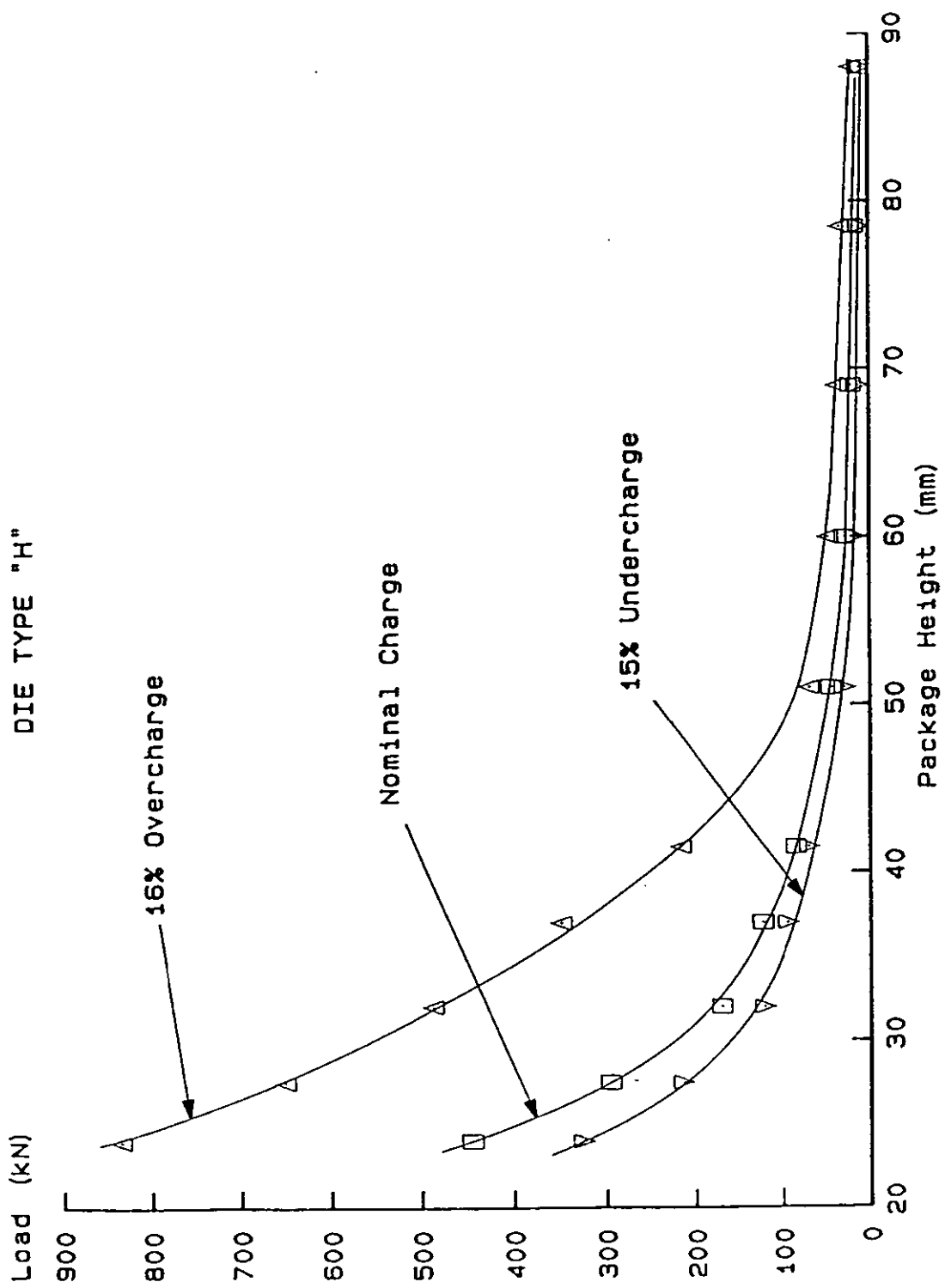

Graph 10.2 Varying the Charge Mass

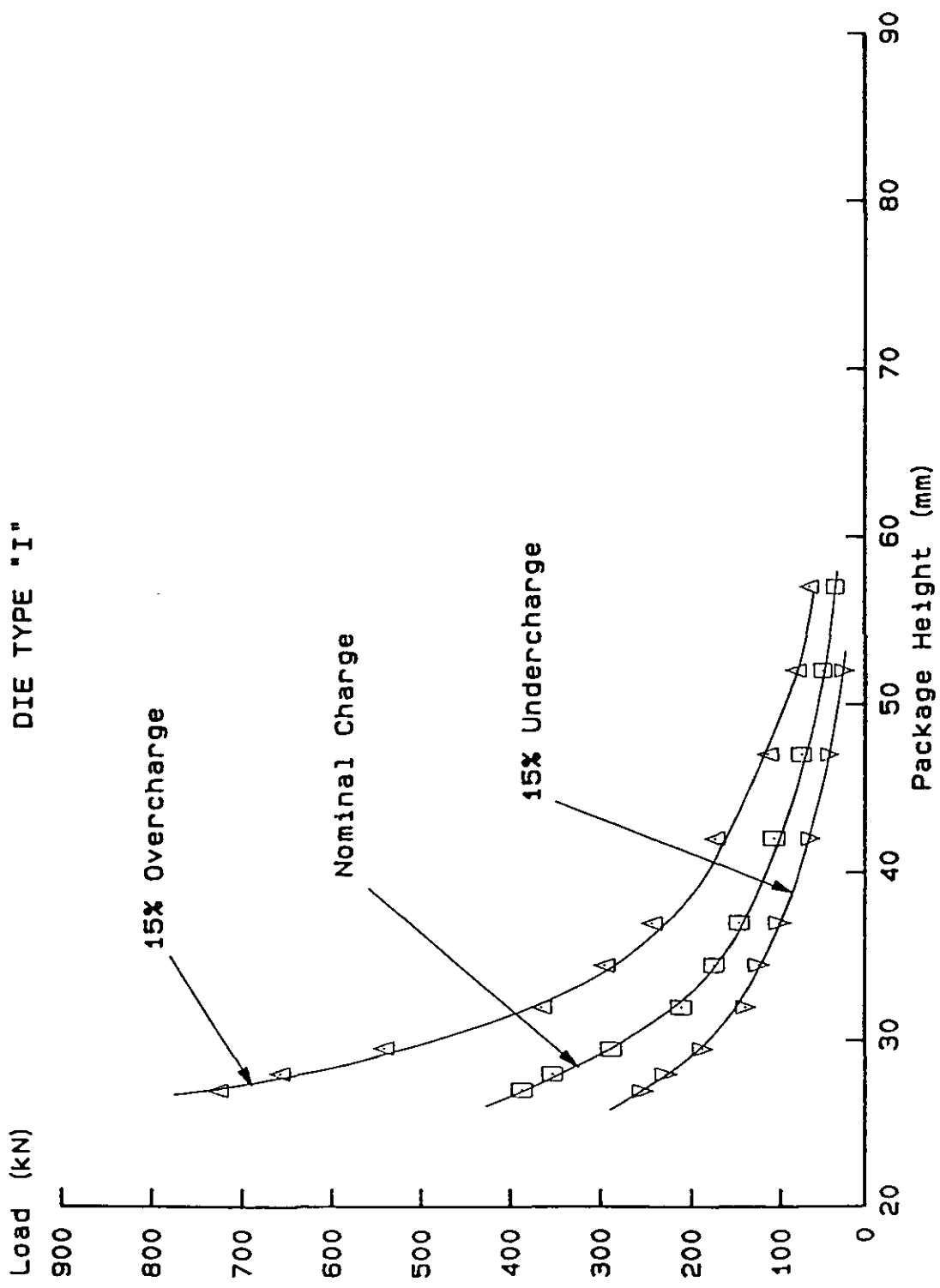

Graph 10.3 Varying the Charge Mass

Graph 10.4 Pre-compaction Test.

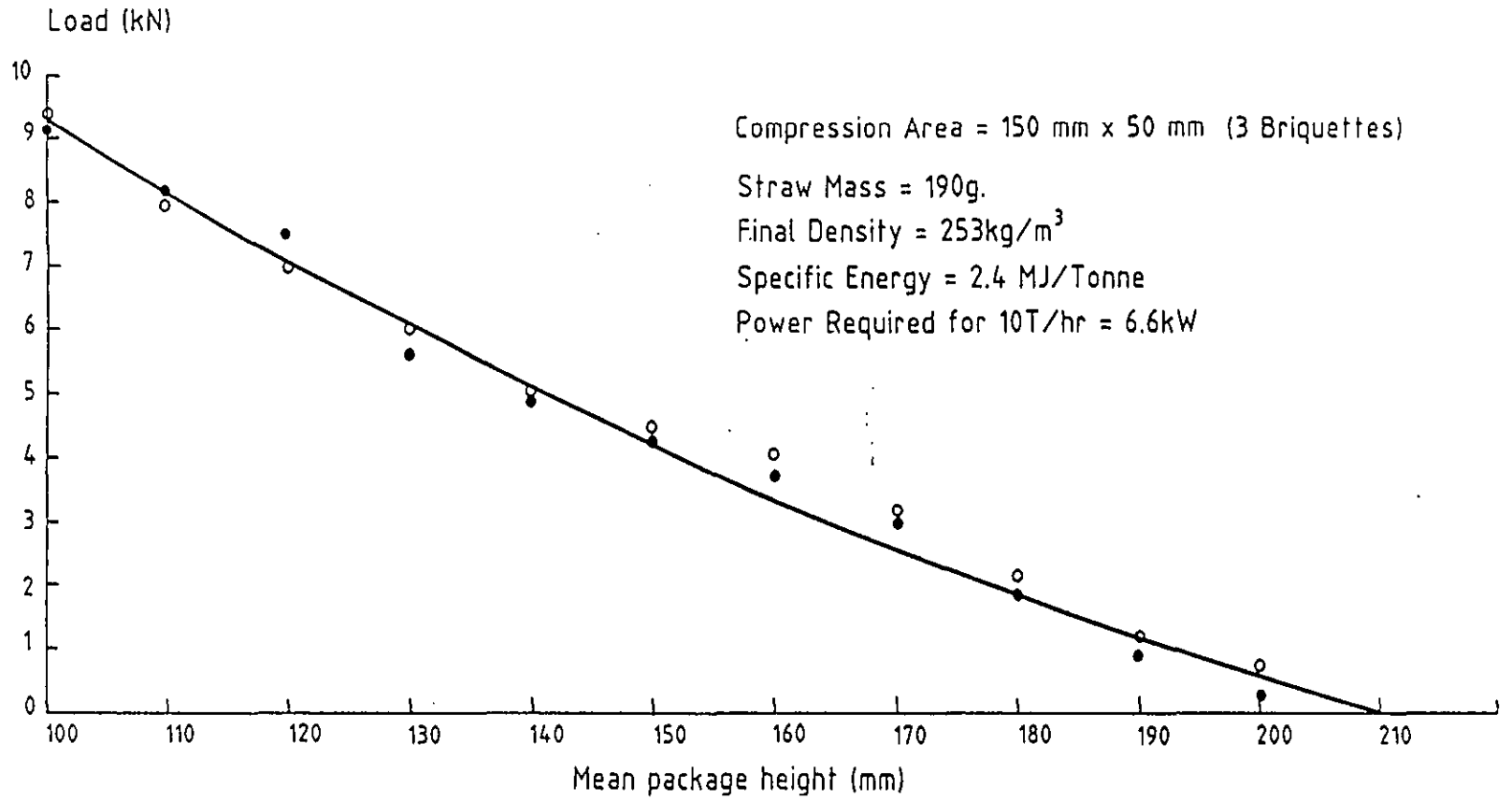

GRAPH OF PRECOMPACTION FORCE vs PACKAGE HEIGHT



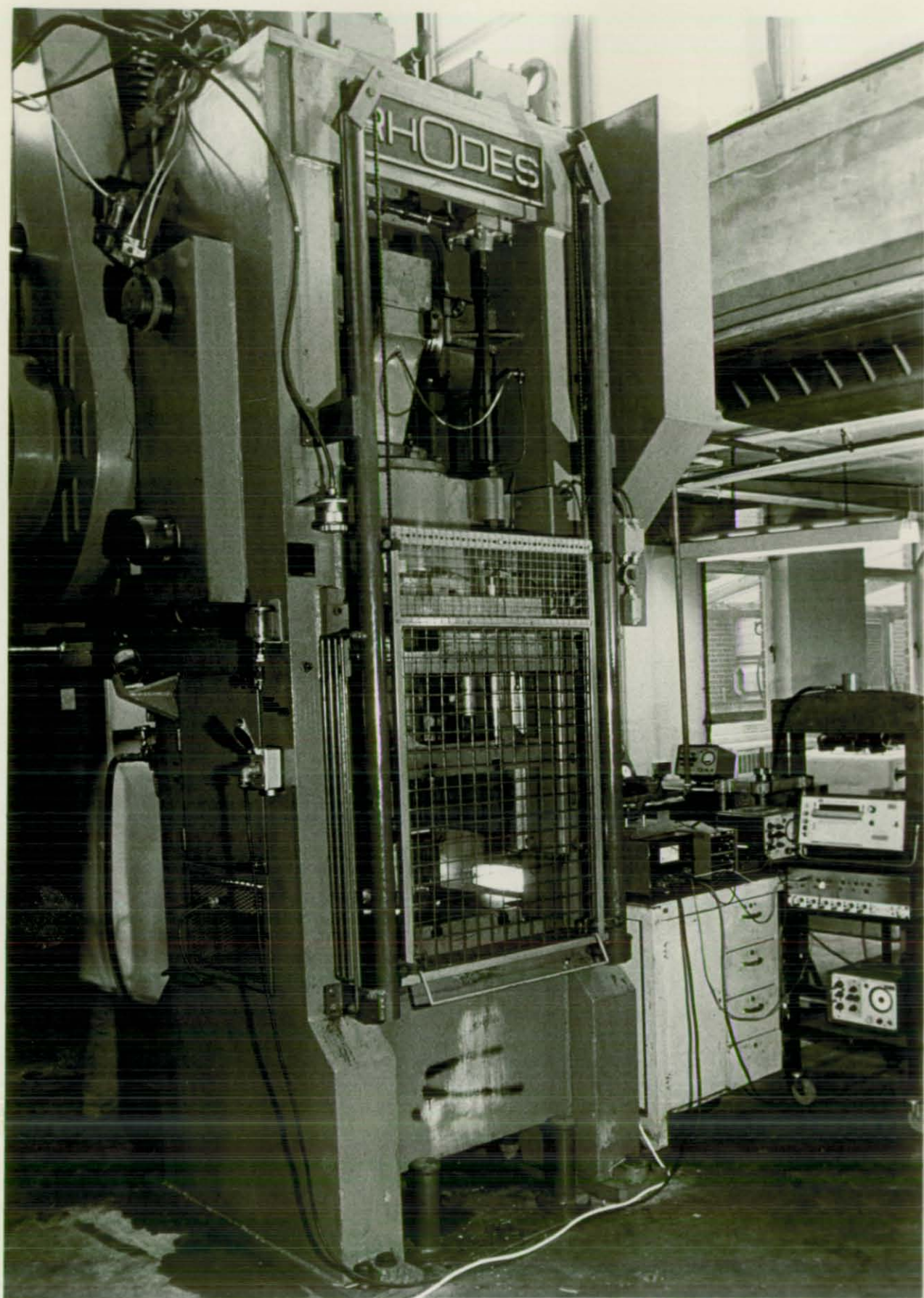
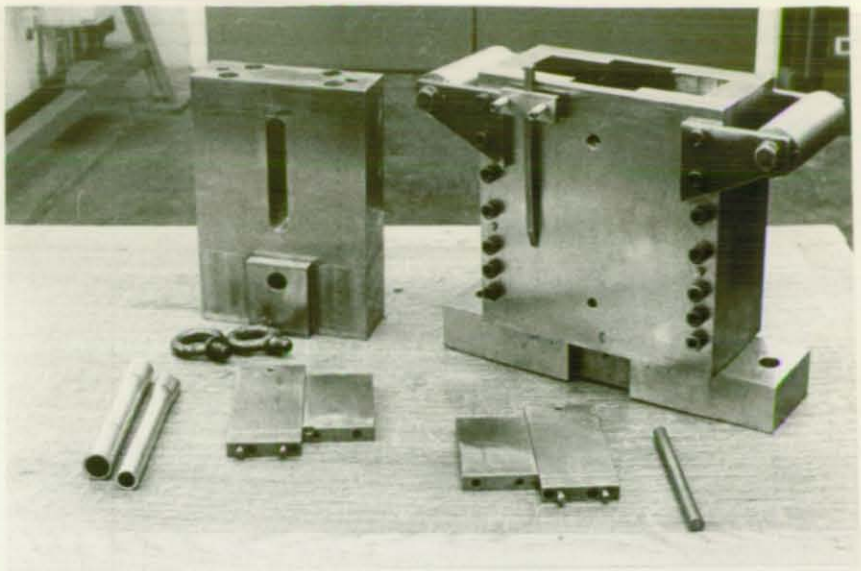
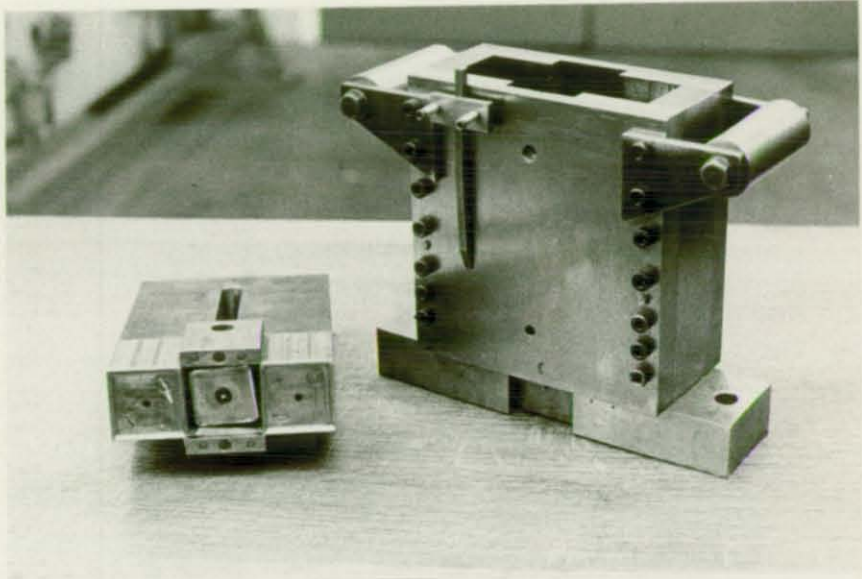

PLATE 10.1 RHODES 100 TON MECHANICAL PRESS



(a) Test Rig Components



(b) Die Type 'H' with ejectors

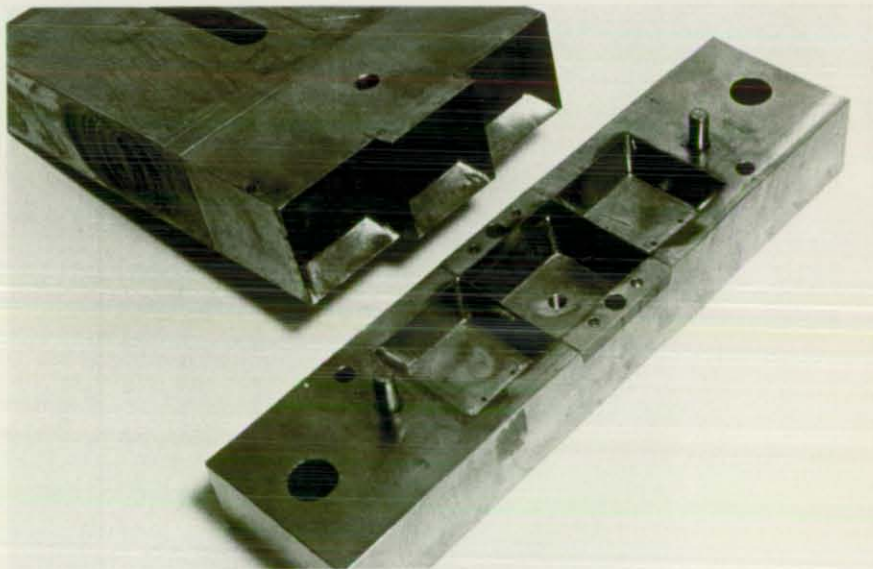

(c) Die Type 'I'

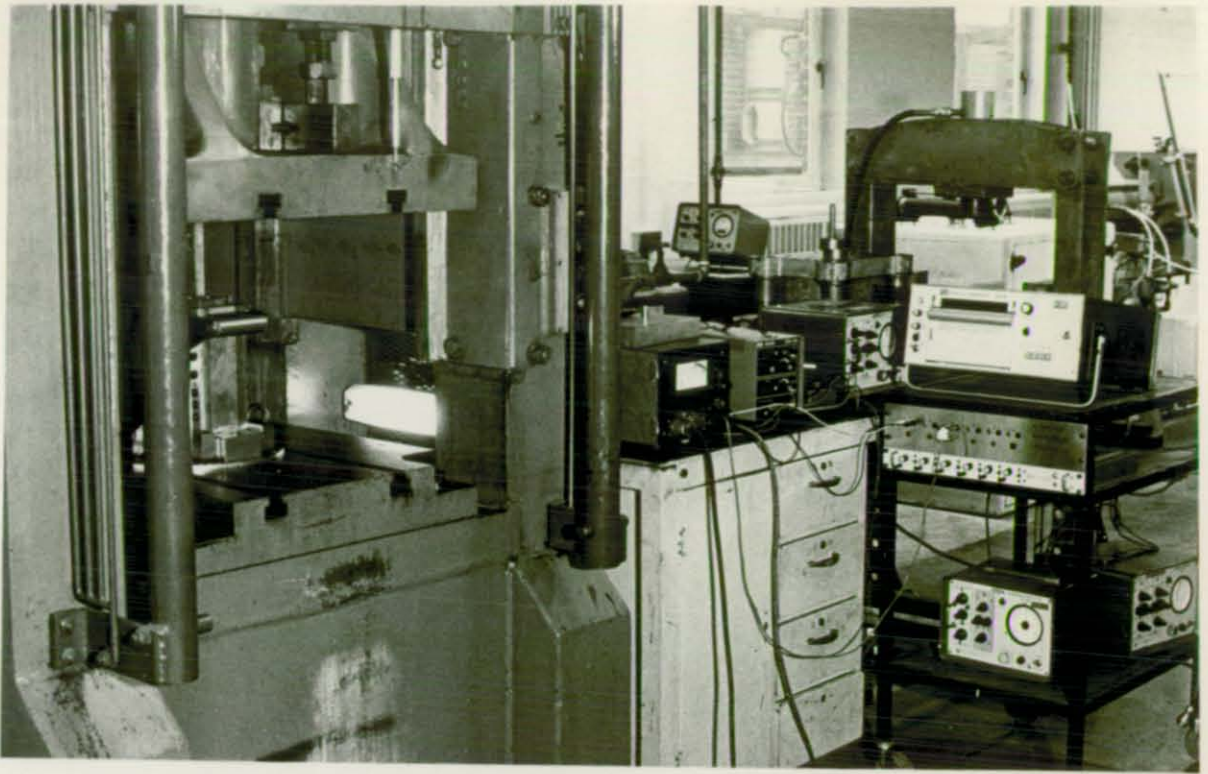

(a) Measuring Equipment

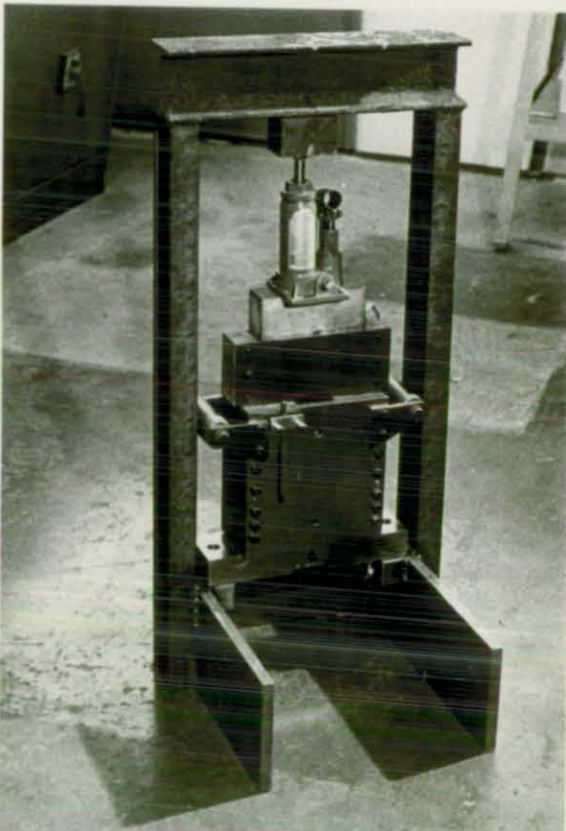

(b) Priming; Stage 1

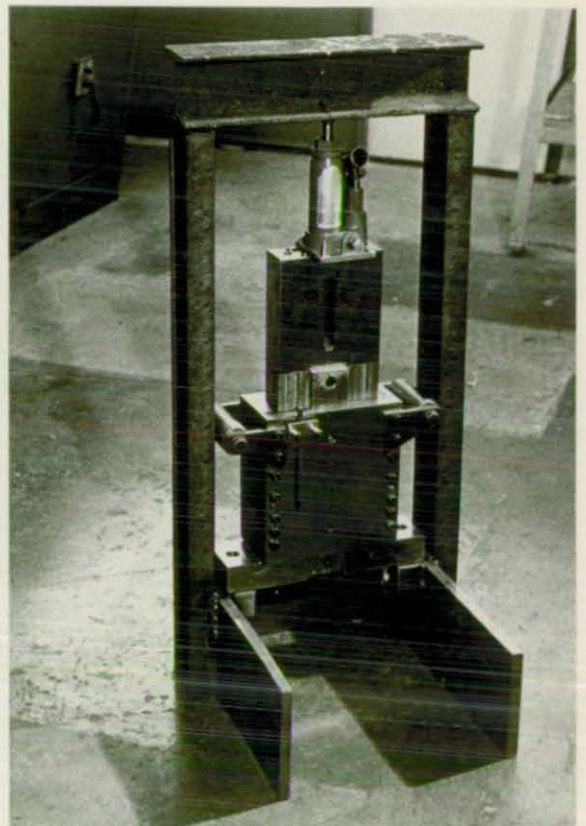

(c) Priming; Stage 2

## 11. THE PRE-COMPACTOR

The need for a separate device has been defined which would provide a continuous input to the final stage of the machine. An approximately uniform density feed would be required in order to achieve a constant output of well formed briquettes and the flow rate of the pre-compactor stage should be consistent with the design specification.

It has been established that orientation of straw fibres in the longitudinal direction of flow would drastically reduce the durability of the briquettes and so, any significant degree of longitudinal organisation would be unacceptable. Although it has been found permissible to allow straw fibres to lie parallel to the loading axis, this would be very difficult to achieve in practice. The simplest and most appropriate solution must, therefore be to devise a continuous flow machine which neither orientates in one direction nor the other but simply reduces the volume of the straw mass without causing major modification to the random position of the fibres within the swath.

It has been established that the in-feed to the pre-compactor would be provided by a conventional pick-up auger which is known to lightly compress the swath and present it, typically, as a square cross section of about 250 mm to 300 mm side as with existing farm machinery. The pre-compactor would need to convey the straw and compress its cross section perpendicular to the direction of flow, reducing the dimensions to a size suitable for in-feed to the final stage discs. The dimension in the direction of flow must remain essentially unchanged because longitudinal extension would doubtless increase fibre orientation, whereas longitudinal compression would also increase power consumption unnecessarily.

In this section of research, the forces acting at appropriate pre-compactor densities are further examined, and a practicable method for achieving such a feed is proposed. A demonstration rig, designed, built and tested by the investigator to verify the principles and the power consumption for this stage of compression is also described.

## 11.1 INVESTIGATION INTO FORCES AND STRAW DENSITY

### 11.1.1 Experimentation

A series of experiments represented the reduction of a short length of a continuous feed from a cross section of 250 mm x 250 mm to a cross section measuring 60 mm x 60 mm by linear, slow speed compression. The straw was compressed in two stages in perpendicular directions but the length of the package remained unchanged. A specially designed apparatus, fabricated from plywood, permitted the straw to be constrained as a 60 mm thick slab at and during the second loading operation. The applied forces were measured and plotted against the height of the straw package in the direction of loading. Direct load/displacement readings could be taken from the instrumentation attached to the Instron 8302 tensile/compressive testing machine which was used to supply the relatively small forces needed for this experiment.

The mass of straw compressed was consistent with that likely to be encountered in a 400 mm length of swath in the field and corresponded to the specified flow rate and operating speed.

Stage 1

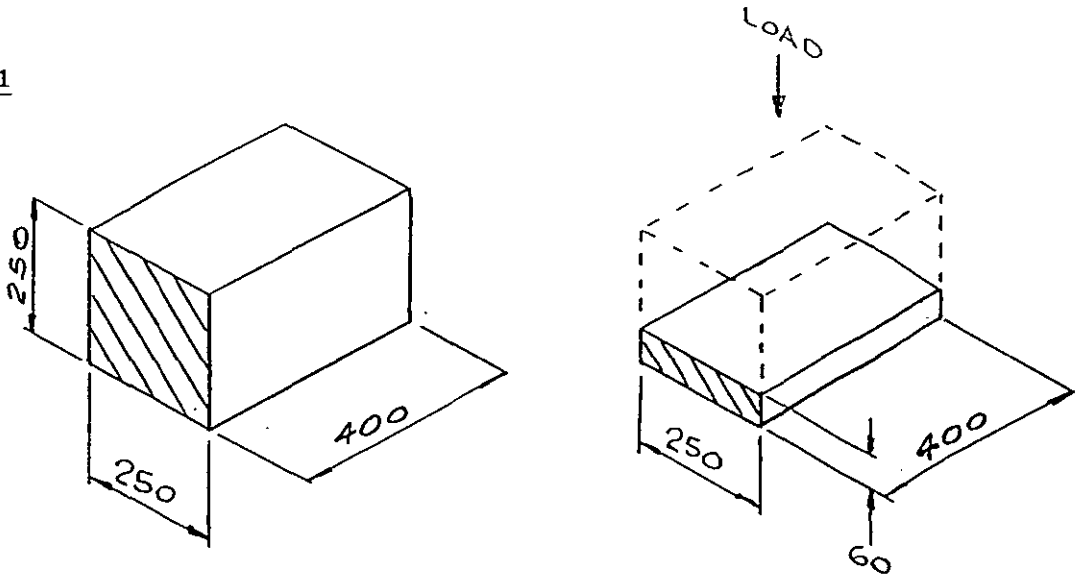

Stage 2

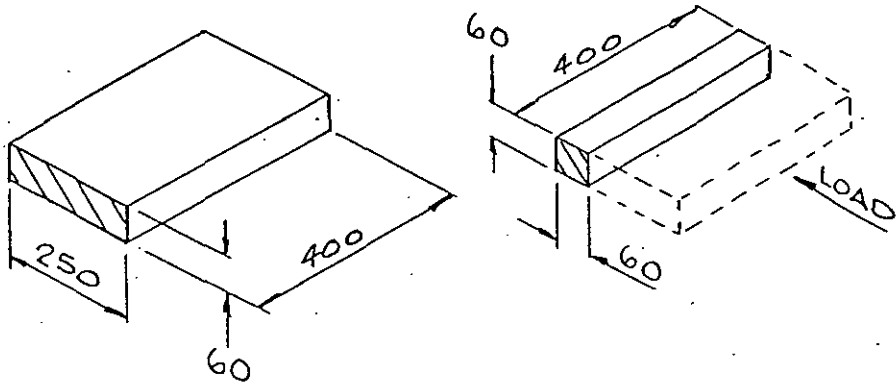

Figure 11.0.1a Reduction of the Cross Section.

11.1.2 Results

Graph 11.1 is a single representation of numerous similar tests and shows the loadings measured at both stage 1 and stage 2 of the experiment.

The average values for the maximum pressures derived from the results were  $21.5 \text{ kN/m}^2$  and  $720 \text{ kN/m}^2$  at stage 1 and 2 respectively. Also, by integration of the load curve, the work done in compression was found to be 76 J and 770 J for the two stages. Using this information, it could be shown that the specific energy requirement for this pre-compaction was 1.8 MJ/Tonne and hence it was deduced that the power required to drive a suitable feed for the final stage discs would be around 4.7 kW, excluding mechanical losses.

The reduction in cross section, suggested here, resulted in a mean straw density of about  $330 \text{ kg/m}^3$ , held under load. On release, straw at this density would not hold together as a durable package. It was important to note, therefore, that the output from the pre-compactor would need to be fully enclosed to control the shape and size of the input to the next stage of the machine.

## 11.2 DESIGN FEATURES OF A BELT TYPE PRE-COMPACTOR

The design synthesis suggested that the converging belt system (described in clause 6.4.2) would provide the most favourable concept for development, although some evaluation was also made of other researchers' analysis of the conical auger arrangement<sup>(57,58)</sup>. The auger proposal was initially favoured by the sponsoring company and, indeed, built into the first prototype but eventually proved to be unsatisfactory and was finally replaced. In order to demonstrate the viability of the converging belt concept, the author decided to build and test a machine to simulate the pre-compactor without the financial support of the sponsor.

### 11.2.1 Rig Design

The included angle at which the conveyers may be inclined has a finite limit. The major influences on this limit are:

- The frictional grip of the conveyer surfaces.
- Opposing forces from stationary surfaces.
- Assisting forces from adjacent stages.
- The limit of adhesion of the outer layer of straw fibres to the remainder of the straw package.

The forces acting on straw in the belt conveyer system have been examined and details are given in Appendix IV. The analysis confirms that the materials and form of the conveyers should be chosen to give maximum grip and that side-wall friction should be kept small, possibly by the use of free rolling elements in contact with the straw which stand proud of the static surface.

The demonstration rig was necessarily built on a low budget using readily available component parts wherever possible, even at the expense of design integrity. The driving gears, for example, were not chosen in relation to the required strength but were simply selected from gears surplus to requirements from previous University projects. The rig was not intended to represent a complete pre-compacting system for straw, but served, instead, to illustrate and investigate a principle of operation. Because the compactor device would be immobile, it would need straw to be presented to it. The machine was built in an upright posture so that a measured charge of straw could be delivered from a simple transparent hopper. In the field, a pre-compactor system would most likely be operated in an horizontal attitude and be continually fed from the pick-up. However, the



gravitational effect on the low mass fibres in the hopper was thought to be negligible in relation to the potential driving forces and so the results would not be significantly affected by this deviation.

A production machine, operating on the same principle, would need conveyers which prevented straw becoming entrapped in their working surfaces and ultimately in the driving mechanism. For the demonstration, readily available multiple vee-belts were used for the primary stage and triplex roller chains for the second stage compression medium. Calculated predictions of the normal forces on the conveyers, based on test results from section 11.1 had suggested that considerable tensile strength would be required and the need for an expeditious and cost effective solution was thought to out-weigh the inevitable problem of straw escaping and the difficulty in maintaining continuous lubrication. The rig would, in any case, only be required to operate for very limited periods in the laboratory and could be cleaned out regularly by hand.

The machine was mounted on a sturdy cradle and powered by a 4.5 kW three-phase electric motor geared to give a throughput rate of 0.42 m/s (roughly equivalent to 2 tonnes per hour in field operation). an additional facility for slow hand cranking was also incorporated.

The method of operation of the compactor design is described by the schematic drawing, figure 11.2.1a. Plate 11.1 shows the complete powered assembly.

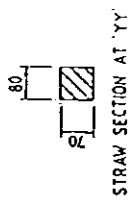
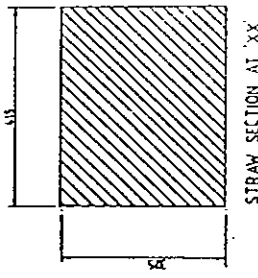

NOTE  
ALL DRIVES AND SUPPORTING FRAMEWORK  
OMITTED FOR CLARITY.  
ALL DIMENSIONS ARE IN MILLIMETRES.

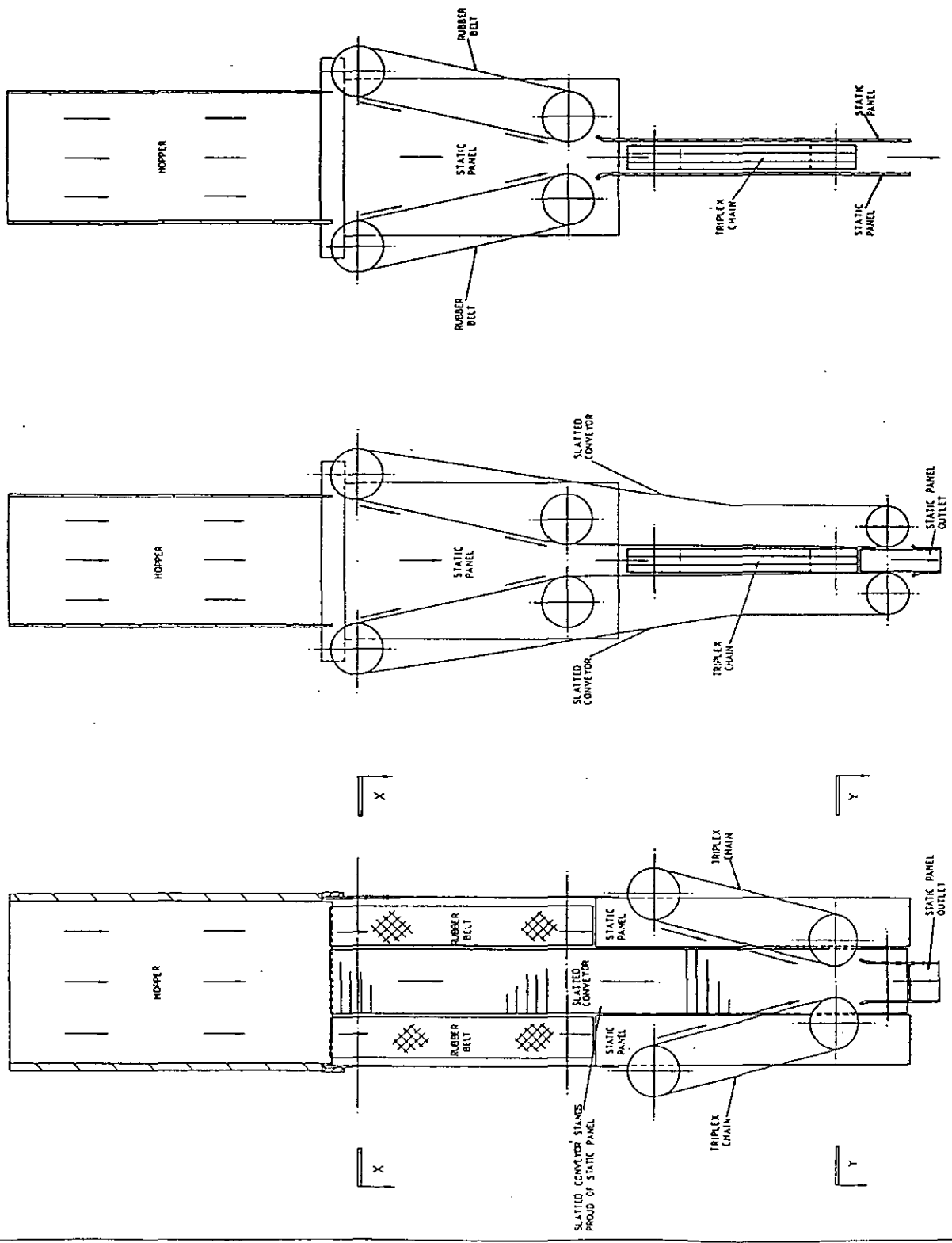

SECTION ON 'BB'

SECTION ON 'AA'

SECTIONAL ELEVATION

Loughborough University of Technology	
TITLE	
STRAW PRE-COMPACTOR SCHEMATIC	
SCALE	1:1
DRAWN BY	PCB:SLC
CHECKED BY	

Figure 11.2.1a

### 11.2.2 The Elimination of Drag

The practical work highlighted, in particular, the need to eliminate static surfaces acting directly upon compressed straw which cause drag. Like the linear compression tests, the demonstration rig compressed straw in two stages: first in one direction and then in a perpendicular direction. The original design used two opposing conveyer surfaces for each stage and the remainder of the enclosure consisted of static steel panels. Although straw was conveyed through the first stage, this design failed because it was prevented from moving through the triplex chains by the frictional resistance of the stationary side plates.

Retrospective analysis of the failure showed that, at the start of the second stage, the normal force acting on the side plates was much greater than that acting in the direction of the secondary chain conveyers. It was essential, therefore, to eliminate the frictional resistance of the side plates. In the demonstration rig, this was achieved by replacing the static sides with parallel moving conveyers running on backing rails. These conveyers then extended over the whole length of the machine and with this modification, the second stage of the machine presented four moving surfaces to the straw over its whole length. Continuous compaction was then successfully achieved. Examination of the force system shows that it would not be essential to provide moving surfaces over the whole length of the compactor as, at some point in their convergence the transporting force of the conveyers would exceed the drag force from stationary side-plates, however, the likelihood of a jam under abnormal conditions would be increased.

The problem of static surfaces in machine design should not be underestimated, their presence would inevitably generate heat and consume power. Where they are unavoidable, they should be smooth and present no traps to the straw. To reduce frictional drag, essential static guide panels should be positioned further apart than the initial width of the straw rope they contain, thus allowing for some expansion. There should be no attempt to extrude straw between converging static plates as this would be very inefficient and would almost certainly fail.

### 11.3 TESTING THE PRE-COMPACTOR RIG

#### 11.3.1 Orientation, Density and Fibre Damage

Straw was effectively carried through the device when either hand cranked or run under power. Once the swath had entered the machine, it was delivered in a very positive aggressive manner.

Comparisons of the mass per unit length on input and output showed little difference, hence the objective of restricting the compression to the perpendicular plane had been met. A visual examination of the output showed only a marginal tendency for fibre orientations but there was no means to quantify this.

With prolonged operation of the rig, straw passed behind the triplex chains and became encrusted on the sprockets effectively increasing their pitch diameter: the chains became over-tight and the overloaded machine stopped. It would be useful to note, therefore, that it must not be assumed that stray fibres would be ground up and

dispersed by rotating machine elements. On the contrary, the build-up of immovable clutches of compressed straws must be expected to occur in every snag or crevice and this should be carefully considered at the detail design stage.

### 11.3.2 Power Consumption

A pair of laboratory wattmeters were externally wired to the motor with a switchable circuit so that they could be isolated during high current starting. The power consumption of the compactor was measured both running empty and under load; the difference giving the energy absorbed by the straw in compression. The experiment was repeated for different input densities (the length of the charge remaining constant). Table 11.3.2a lists the results and Graph 11.2 illustrates how power consumption varied with output density.

Mass per metre (kg)	Output Density (kg/m <sup>3</sup> )	Power Consumed (kW)	Mass Flow Rate (t/hr)	Specific Energy (MJ/t)	Power Req'd at 10 t/hr (kW)
1.0	179	0.9	1.4	2.3	6.5
1.2	214	1.0	1.7	2.2	6.0
1.4	250	1.1	1.9	2.0	5.7
1.4	250	1.2	1.9	2.2	6.2
1.6	286	1.5	2.2	2.4	6.7
1.6	286	1.9	2.2	3.2	8.8
1.8	321	2.2	2.5	3.2	8.8
2.0	357	2.1	2.8	2.7	7.6

Table 11.3.2a Experimental Results for the Pre-compactor Rig.

#### 11.4 CONCLUSIONS

The forces encountered at the pre-compaction stage are of a completely different magnitude to those present in the disc compactor. The maximum pressure was found to be approximately 1.5 per cent of that to be expected at the nip point of compacting discs and the specific energy consumed was only 1 per cent of the overall total for the process. The type of technology required to fulfil the pre-compactor requirement would not be dissimilar to that used in existing farm balers and harvesters.

The demonstration rig verified that the proposed principle of operation could meet the required specification for the machine and the power consumption results approximately agreed with the figures from the static tests. Construction of the machine highlighted several key features which would need to be included in a full scale design. The use of roller chains disproved the notion that only high friction surfaces or extended tines embedded in the swath would convey the material. Indeed, tines should be avoided as they would require considerable additional driving power and cause the fibres to separate into layers and thereby reduce the durability of the end product.

The experimental work with the pre-compactor showed that an output density of between 250 and 300 kg/m<sup>3</sup> was required and at this level of compaction the straw would expand rapidly and uncontrollably if left unchecked. The expansion would produce a normal force on any static delivery chute placed immediately adjacent to the output which would be virtually equivalent to the load taken by the final rollers and this would cause excess drag which could not be tolerated.

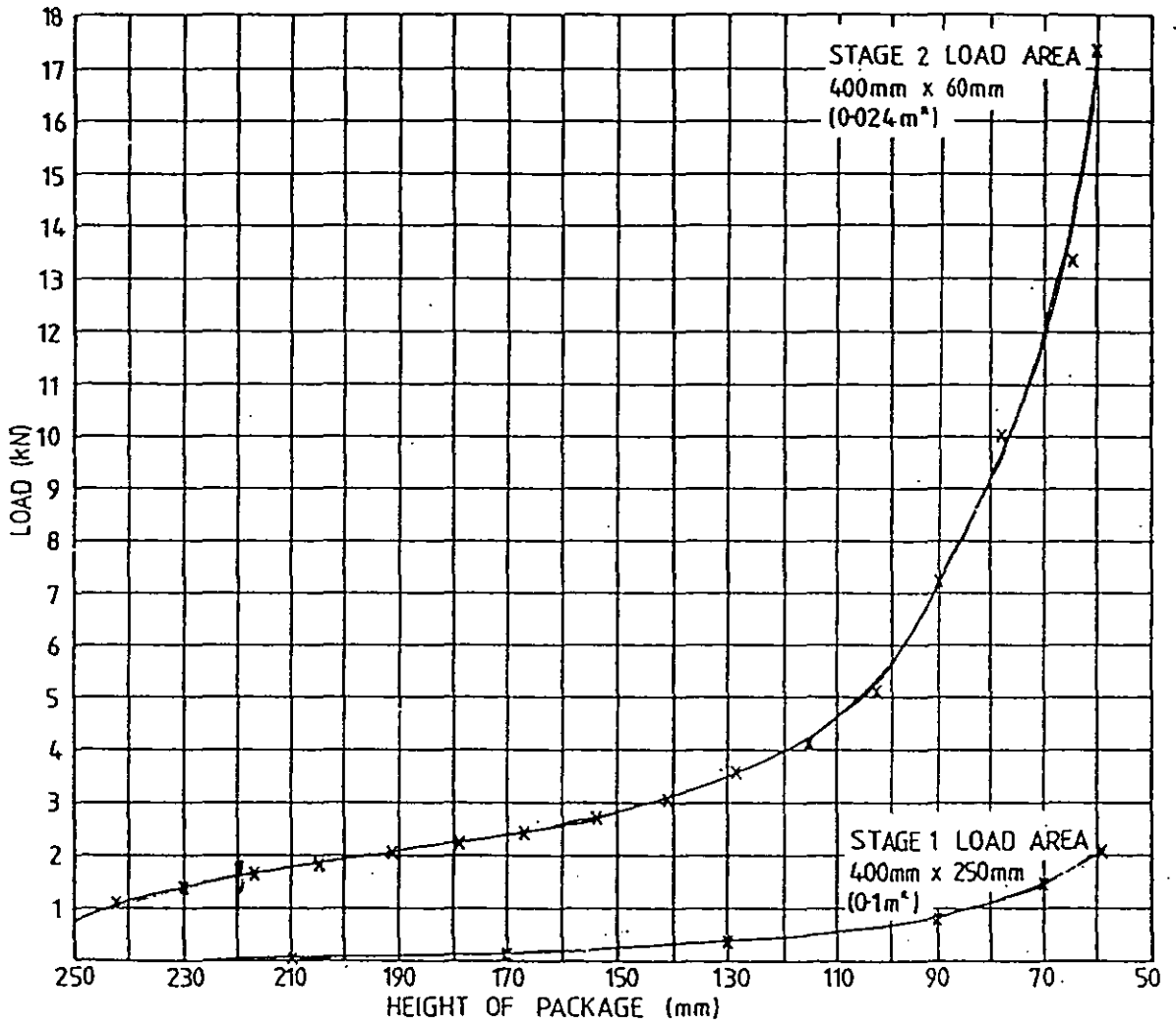

PRECOMPACTOR SLOW COMPRESSION TESTS  
 MASS OF CHARGE 480g

Graph 11.1

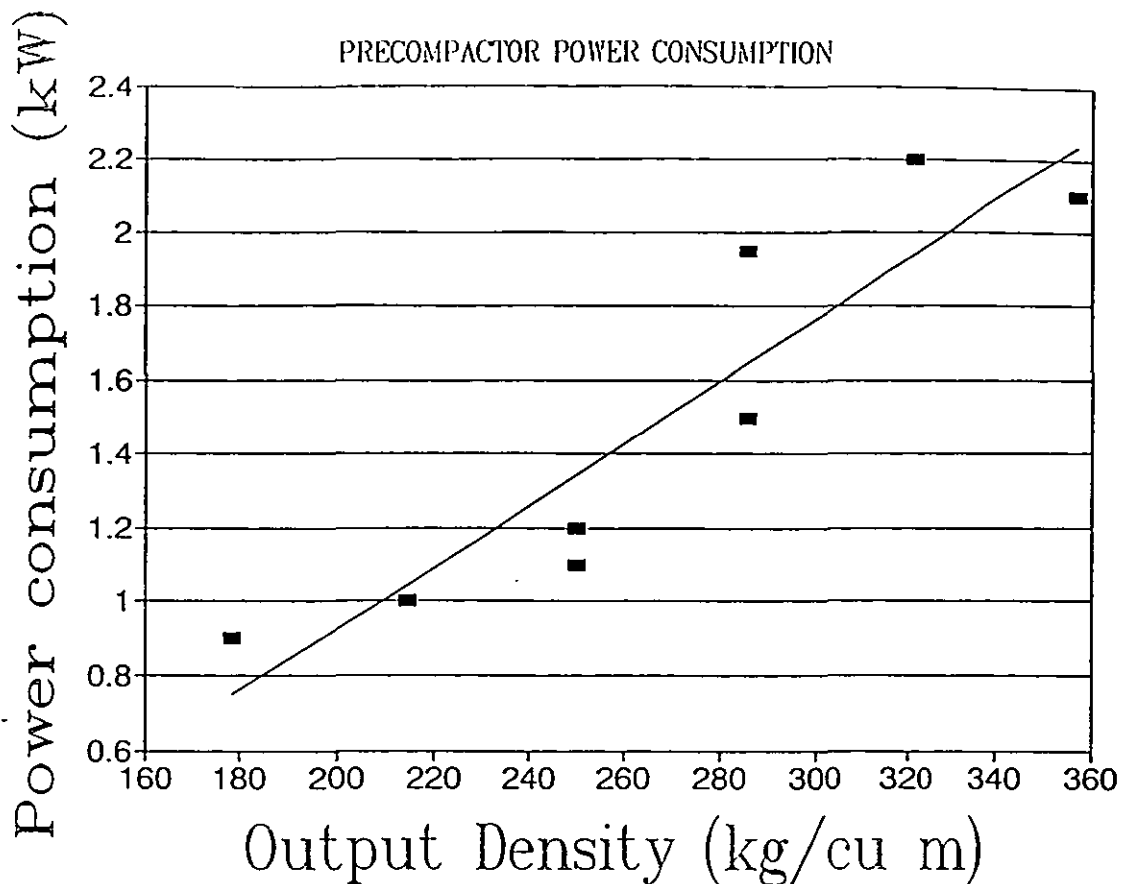

Regression Output:

Constant	-0.745833
Std. Error on Y Est	0.2262568
R squared	0.839371
No. of Observations	8
Degrees of Freedom	6
X coefficient	0.0083611
Std. Error on X	0.0014932

i.e.  $y = 0.00836 x - 0.746$

or  $P = 8.36 \rho - 746$

where  $P$  = Power required to compress the straw (Watts).

and  $\rho$  = The Output Density ( $\text{kg/m}^3$ )

Graph 11.2



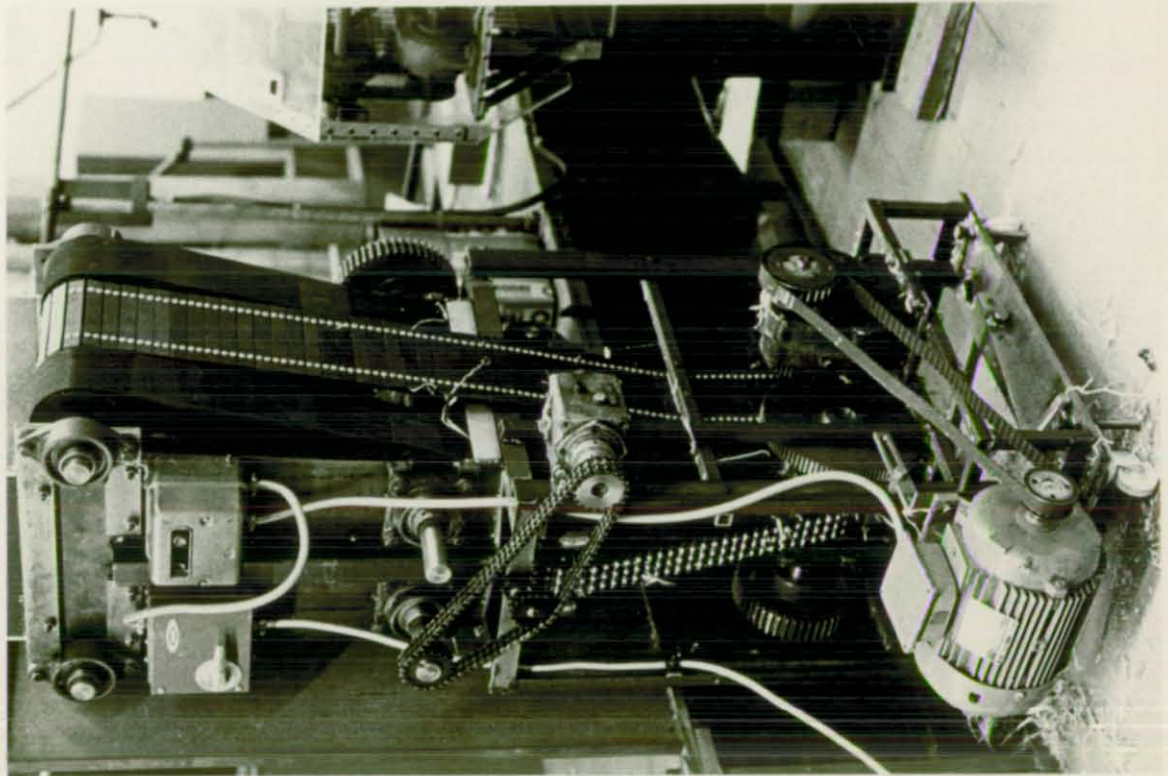
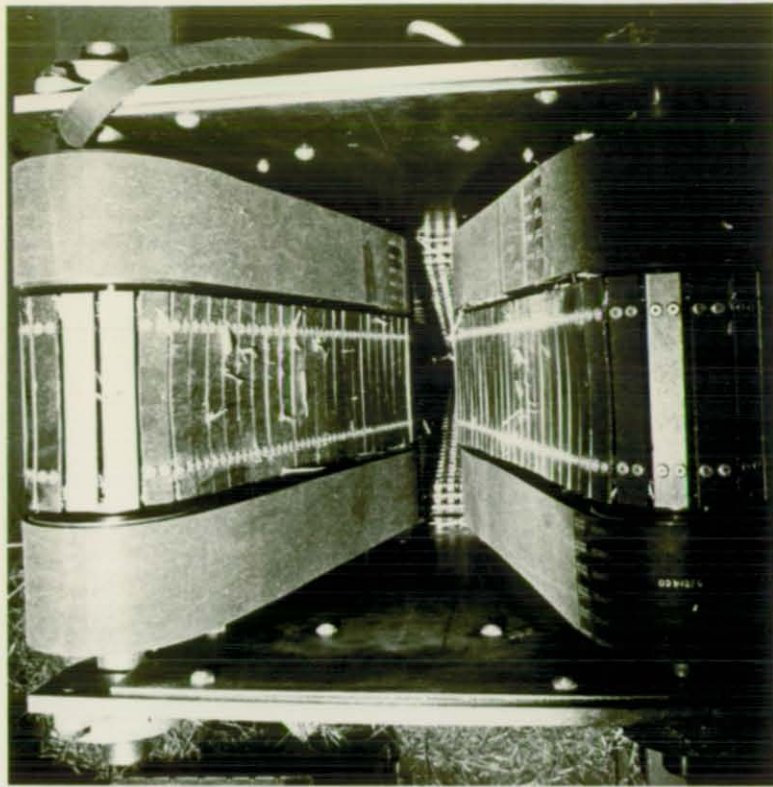

PLATE 11.1 PRE-COMPACTOR DEMONSTRATION RIG

## 12. CONCLUSIONS AND RECOMMENDATIONS FOR FURTHER WORK

### 12.1 SUMMARY OF RESEARCH

A study of the economic and environmental problems and opportunities of straw utilisation led to the potentially promising concept of a mobile briquetting process. The subsequent research and development programme sought to provide a better understanding of the behaviour of cereal straw under compression. Extensive tests were carried out to establish empirical rules for the material's non-linear mechanical behaviour and relationships proposed by earlier researchers were evaluated and, in some cases, disputed (section 7.5). The factors affecting straw waferability were comprehensively explored.

Straw was generally found to be a difficult and unresponsive material to manipulate. In order to gain a coherent understanding of its often discordant behaviour, the laboratory work required considerable intuitive and innovative input, together with much perseverance and repetition. The number of permutations of the experimental parameters was found to be very formidable and a large number of directed experiments were needed to obtain reliable data. The research was structured to address each of the variables in turn, and thereby to build a broad understanding. The separate effects of varying applied pressure (sections 6.3, 7.5), Moisture Content (sections 9.1-9.3), Die shape and size (sections 8.1-8.7), rate of compression (sections 10.1-10.6), relaxation/time-under-load (sections 7.4, 7.6, 10.5), charge mass (section 8.3), botanical and species composition (sections 7.1, 7.4), chop length (section 7.4), and fibre orientation (section 7.3) were all documented. Further, a considered and experimentally proven hypothesis was offered for the mechanism of bonding of the fibres under load.

Several variants of a simple closed piston and die were tested and their usefulness in continuous production assessed. Energy efficient separation was demonstrated and significant improvements in briquette quality were achieved by the application of the empirical results to compactor design.

The fundamental elements of a novel mechanical process were identified (section 6.5) and possible alternative concepts compared. These ideas were evaluated by consideration of the raw material's behaviour. The technological feasibility of the favoured solutions were demonstrably proven, both in the laboratory and by the parallel construction of a full size prototype machine by the project sponsors. The prototype, which incorporated most of the ideas generated from the research, was featured in the B.B.C.'s Tomorrows World programme in February 1989. It is shown undergoing successful field trials in the colour photograph inside the front cover.

## 12.2 CONCLUSIONS

Straw may be pressed into medium density briquettes by the simple application of load (see summary of statistics, section 12.5). On release of the load, the straw package quickly expands to about twice its size whereupon it reaches a condition of stability. The required pressure is approximately  $50 \text{ MN/m}^2$ ; less than this sees a marked deterioration in product quality whereas greater pressure gives proportionally little benefit. The predominant mechanism by which the compressed packages retain their shape is the mechanical intermingling and creasing of the fibres. As a consequence, chopping, grinding, layering, orienting and softening by the addition of moisture all significantly reduce the durability of the briquettes. The energy

required to achieve stable compaction (a little over 20 MJ/tonne) is less than 0.2% of the potential heat output of the product, when burnt as a fuel.

Briquettes formed by the continuous compaction/separation process, devised to achieve the specified production rate, were found to be at a considerable durability disadvantage when compared with briquettes formed in closed die laboratory rigs. This reduction in bond strength was the inevitable and unavoidable consequence of the shearing action. The quality of the final product, however, could be improved by modification of the die cavity and a shape was developed which would consistently produce 'sheared' briquettes of better than 90 per cent durability (A.S.A.E. test). The process was laboratory proven at a production rate commensurate with that specified for the proposed tractor-towed field machine. At this speed, the process showed only a small increase in power requirement which was within the limit available (section 5.1).

The economic viability of the process, while shown by example to be marginally attractive (sections 3.7 and 3.8), was also found to be greatly dependent upon external factors. The commercial prospects for development are likely to improve within a short time. World-wide prices and, in particular, United Kingdom prices for industrial fossil fuels were relatively low over the latter years of the research project, so activity to find alternatives was naturally subdued. Competing fossil fuel prices are dependent upon international market trends and, therefore, beyond the control of the individual; however, Europe is becoming ever more strongly committed to addressing environmental issues. Indeed, imminent U.K. legislation will soon outlaw the current most cost-effective disposal method for straw, so

the current problem of surplus will inevitably become substantially more acute and an effective alternative must be found quickly. Failure to invest in change will inevitably incur large cost penalties for cereal farmers, no longer able to burn their surplus. The potential annual renewable U.K. energy source from waste straw is equivalent to more than  $9 \times 10^{16}$  Joules so, on environmental grounds alone, the possibility of reclaiming this energy by the proposed method has to be seriously considered. The responsibility of providing the necessary investment in machine development and manufacture should not be left to the farmer.

The engineering solution, offered here, gives the possibility of a convenient and potentially profitable fuel product. While the briquettes have proven to be arguably less than ideal in terms of density and durability, nevertheless, they have more than twice the bulk transport density of the most modern and efficient form of baled straw and about four times that of the commonly used round bale system. Medium density briquettes also have the additional capability of being totally machine handled, using conventional and widely available equipment. The briquettes have been successfully burnt in a domestic open fire and, by the sponsor, in controlled combustion trials using a large fluidised bed furnace (intended for coal firing). Whilst the principle of straw briquettes for fuel has thus been demonstrated, the greatest efficiency and cleanliness of combustion would, undoubtedly, only be achieved following a substantial investment in a specially designed burner. Using such equipment, the shape and size of the briquettes offer potentially great improvements in combustion efficiency over other types of straw packages.

### 12.3 COMMENTS ON MACHINE DESIGN

The simplicity of the radial type disc compactor has much to commend it over the more complicated conical type. However, whilst high speed laboratory tests have given sufficient confidence to predict that closure velocity is unlikely to be prohibitive in the latter design, the compression velocity of the radial system would be around five times higher than the maximum tested and the effects of such an additional increase cannot be predicted. One way which has been suggested to reduce the rotating speed for either system, while maintaining the same production rate, would be to compound two or more die rings, side by side on the compaction discs. However, to subject each briquette to shearing on more than two of its sides would undoubtedly result in a further weakening of the mechanical bond within the briquette together with a consequent loss in durability. This approach cannot, therefore, be recommended.

The laboratory tested pre-compactor system (section 11.4) offered a good combination of simplicity and performance. The output of the final stage will surely reflect the quality and consistency of the input fed to it, therefore, the prime consideration of the pre-compactor stage must be to avoid fibre orientation. Nevertheless, there could be room for some simplification of the demonstrated principle. For example, a pair of large diameter rolls with retracting tines could be used to deliver the charge and provide the first stage of compression. The rolls would present a thin slab to suitable second stage converging conveyers. However, the moving parallel track, closing the non-active sides of the second stage, would need to be retained.

A reluctance of straw fibres to migrate sideways into unoccupied spaces within a cavity was regularly observed throughout the experimental work. Unlike some granular materials, straw would not escape from a trap when pressure on it increases but would remain stubbornly in place until the force rose to cause the inevitable stoppage or machine failure. For this reason, it is vital that compactor design should be clean and trap free, particularly in the transfer regions between the various stages of compression. Straw should be accurately directed into the receiving element with the enclosure sides being positively wiped. In the final stage, even small quantities of straw, if allowed to escape onto the die edges, would accumulate and become trapped between the discs generating an intolerable separation force. Of similar importance is the removal or ejection of completed briquettes: it is suggested that a fixed scraper should be fitted to the machine, well away from the nip point, to act as a back-up for the normal ejector system. This would prevent the possibility of briquettes sticking in the die over a complete revolution; a situation which would, undoubtedly, cause mechanical failure.

#### 12.4 SUMMARY OF STATISTICS

The research has shown that the field briquetting process would exhibit the characteristics listed.

##### Product Details.

Mass.....	60 - 70 g
Volume.....	95 - 115 cm <sup>3</sup>
Density.....	600 - 650 kg/m <sup>3</sup>
Bulk Density.....	320 - 330 kg/m <sup>3</sup>
Calorific Value.....	15 MJ/kg
Moisture Content (Optimum).....	15.5 % (w.b.)
(Range).....	9 % - 19 %
Durability Rating.....	93 %

##### Processing Details.

Specific Energy for Pick-up.....	1.2 MJ/t
Pre-compactor Density.....	280 kg/m <sup>3</sup>
Specific Energy for Pre-Compaction....	2.8 MJ/t
Final nip Density.....	1300 - 1400 kg/m <sup>3</sup>
Specific Energy for Final Stage.....	25 MJ/t
Separating Force on Discs* (Conical)..	329 kN
Separating Force on Discs* (Radial)...	164 kN
Total Specific Energy Input (excludes losses and forward motion).....	29 MJ/t
% of Energy Output.....	0.2 %

\* Effective Diameter 466 mm, see Appendix V.



## 12.5 SUGGESTIONS FOR FURTHER WORK

### 12.5.1 Density Variations

Density variation is a topic of great importance which has not yet been fully explored. Two realistic alternatives present themselves:-

- 1: To mechanically or hydraulically vary the volume of the die cavities with a feedback control system detecting the density of straw in the preliminary stages of the machine.
- 2: To regulate the input to the heavily loaded final stages by controlled modification of the flow of loose straw immediately after pick-up.

The evidence is strongly in favour of the latter system because the marginal stability of the briquettes has been found to be influenced, in large measure, by relatively minor modifications to the die shape and size. The introduction of variability in the die volume would infer dimensional fluctuations which would, in turn, vary the potential durability of the product.

Attempts to regulate the feed into the final stage by independently controlling the speed of the pre-compactor and final stage discs would almost certainly be doomed to failure as a variance in the flow rate between the two stages would result in excess fibre orientation and increased power consumption.

The 'converging belt' pre-compactor displayed the ability to draw the charge at a consistent rate. An intermediate hopper or reservoir, fed from the pickup according to the rate of progress along the field, could provide the basis of a controlled solution: the speed of the

compaction stages being varied in unison according to the instantaneous level in the reservoir. The feed into the compacting discs could be preset quite accurately by defining the compression ratio of the pre-compactor (determined by its dimensions).

An alternative arrangement is an intelligent intermediate stage in the machine which is able to sense the density and orientation of the fibres. The sensors would automatically provide the corresponding corrective action via a closed loop control system. This configuration could provide a suitable solution to the problem; however, the development of such a system would involve a substantial further programme of work.

During the experimental research, the assumption was made that the mass of straw per unit die length would be determined, within a small range ( $\pm 15\%$ ) by the prescribed flow rate and that this would effectively fix the quantity of straw available to fill any given die cross section. The two devices, described above, offer the advantage that the input density would not be directly related to the speed of traverse and, therefore, a greater (or lesser) charge could be injected into the same die length. The die shape optimisation (sections 8.4-8.7) indicated that there could be a durability advantage in increasing the depth of the tapered die cavity for a given cross section. A larger briquette mass would also infer a desirable reduction in the speed of rotation.

#### 12.5.2 The Rolling Action of the Dies

Laboratory estimates of the power required to form straw briquettes by continuous compaction have always been conducted by approximating the

rotary compactors with more simple linear devices. When a fibrous material like straw is rolled, however, there will be additional energy consumed as the fibres are forced to change speed and direction during the compression cycle. Compared with linear compaction the individual fibres will suffer additional stretching and bending and will interact with each other generating heat from the frictional forces. The magnitude of the error given by this approximation is, as yet, unknown and the topic remains open to investigation by either mathematical or experimental means.

### 12.5.3 Alternative Uses for the Compactor Technology

The partially developed briquetting technology clearly offers opportunities for high speed and conveniently transportable packaging of other agricultural fibres and crops. Both hay and lucerne (alternatively known as alfalfa; a major world forage crop) have been tried in the straw processing machinery and although hay was found to be largely unresponsive, preliminary tests with lucerne were very promising. Alternative third world crops have yet to be examined but the prospects for further application of the compactor technology, in producing a high value feed material which is both suitably sized and of a palatable density, look very inviting. This diversion could substantially extend the usefulness and viability of the process and deserves thorough investigation.

## APPENDIX I

### Supplementary Experimental Data

#### Contents

- Chart 1 Preliminary die shape test results.
- Graph (i) Generalised Pressure/Density Results.
- Graph (ii) Loading Curve: Closed Rectangular Dies.
- Graph (iii) Loading Curve: Closed Chamfered Dies.

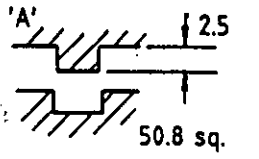
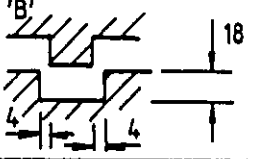
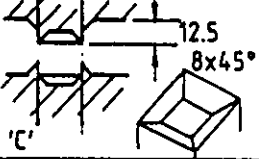
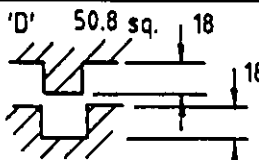
TEST No.	ALL RESULTS ARE FOR CENTRE BRICK DIE. DIE SHAPE	CONDITIONS	CHART 1. (SHEET 1 of 2)				REL <sup>x</sup> HEIGHT (mm)	RELAXED DENSITY (kg/m <sup>3</sup> )	RELAX'N RATE	REMARKS
			APP. FORCE (kN)	MASS (g)	COMP. HEIGHT (mm)	COMP. DENSITY (kg/m <sup>3</sup> )				
1.		DIFFICULTY IN LOADING DIE - CHARGE SPLIT	375	73	19	1489	48	588	2.53	BRIQUETTE SPLIT DUE TO UNEVEN LOADING - DISREGARD RESULT
2.	DITTO	CHARGE LOADED IN CONTINUOUS RANDOM SWATH	375	68	19	1387	43	614	2.26	FAIR EDGES RATHER LOOSELY ATTACHED
3.		—	375	65	17.5	1439	38	629	2.29	NOT QUITE SHEARED THROUGH. TOP CORNERS UNTIDY.
4.		—	375	64	22 MAX.	1429	37	760	1.88	GOOD BRIQUETTE BUT SOME LOOSE STRANDS A LITTLE EASIER TO EXTRACT
5.	'C'	—	375	72	24 MAX.	1441	43	730	1.98	DITTO
6.	'C'	PUNCH & DIES SPRAYED WITH WATER JUST PRIOR TO APPLYING LOAD	375	74 (DRY)	24.5	1444	61 AVE	508	2.84	VERY LOOSE EDGES. UNACCEPTABLE
7.		BRIQUETTE ALMOST TOTALLY SUNK INTO DIE	375	76	20	1473	40	736	2.00	WELL STRUCTURED BRIQUETTE BUT VERY DIFFICULT TO EXTRACT.

ALL RESULTS ARE FOR CENTRE BRICK DIE

CHART 1. (SHEET 2 of 2)

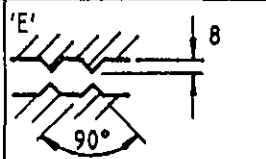
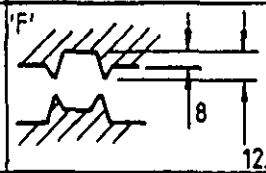
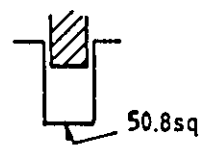
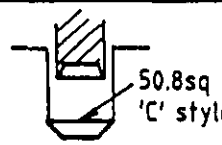
TEST No.	DIE SHAPE	CONDITIONS	CHART 1. (SHEET 2 of 2)				REL. <sup>x</sup> HEIGHT (mm)	RELAXED DENSITY (kg/m <sup>3</sup> )	RELAX'N RATE	REMARKS
			APP. FORCE (kN)	MASS (g)	COMP. HEIGHT (mm)	COMP. DENSITY (kg/m <sup>3</sup> )				
8.		AS 'C' BUT NO STEP	375	66	22.5	1432	41	703	2.04	EXAGGERATED 45° SHEAR PLANES. ONE HALF DID NOT SEPERATE UNTIL HANDLED
9.	'C'	—	375	70	23	1478	40	767	1.93	SOME 45° SHEARING PRESENT BUT LESS THAN ABOVE
10.		—	375	63	23	1478	37	800	1.85	UNTIDY SHEARING. SHEASED ON DEEP SLOPING SIDE. FALLS EASILY FROM DIE.
11.		CLOSED DIE - SINGLE BRIQUETTE	125	60	17	1368	37	628	2.18	
12.	DITTO	DITTO	170	65	17	1482	37	681	2.18	TEST FOR OBTAINING FORCE/DISPLACEMENT DIAGRAM
13.		DITTO	125	63	23.5	1295	42	653	1.98	
14.	DITTO	DITTO	218	66	22.5	1432	38.5	755	1.90	TEST FOR OBTAINING FORCE/DISPLACEMENT DIAGRAM

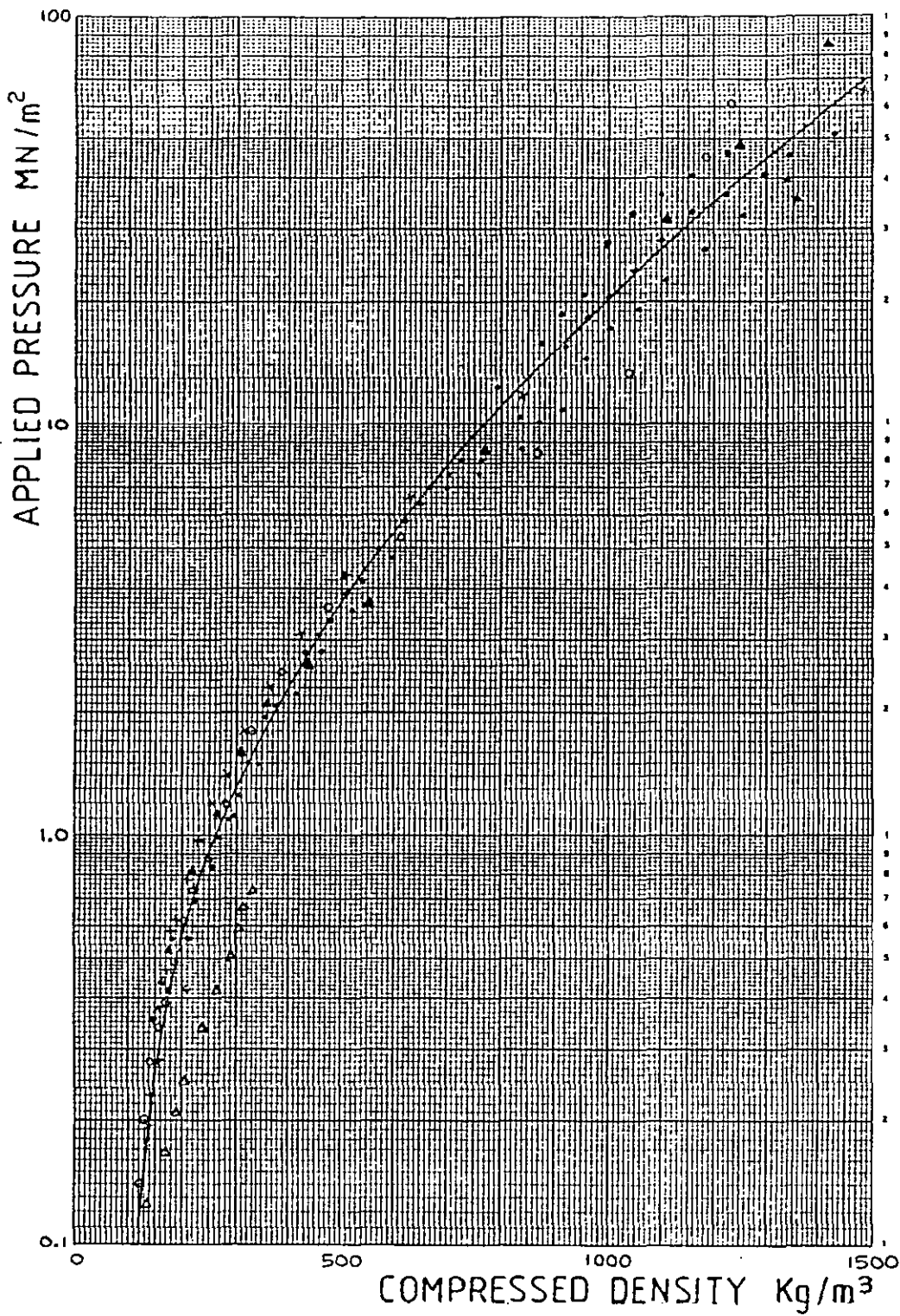

CLOSED DIE PRESSURE/DENSITY RESULTS

- — 55mm x 65mm FLAT FACED DIES
- — 55mm x 65mm DIES WITH 5mm x 45° CHAMFERS ON 2-SIDES
- × — 50mm x 50mm FLAT FACED DIES
- ▲ — 50mm x 50mm DIES WITH 8mm x 45° CHAMFERS ON 4-SIDES
- △ — 400mm x 60mm PRE-COMPACTOR RIG

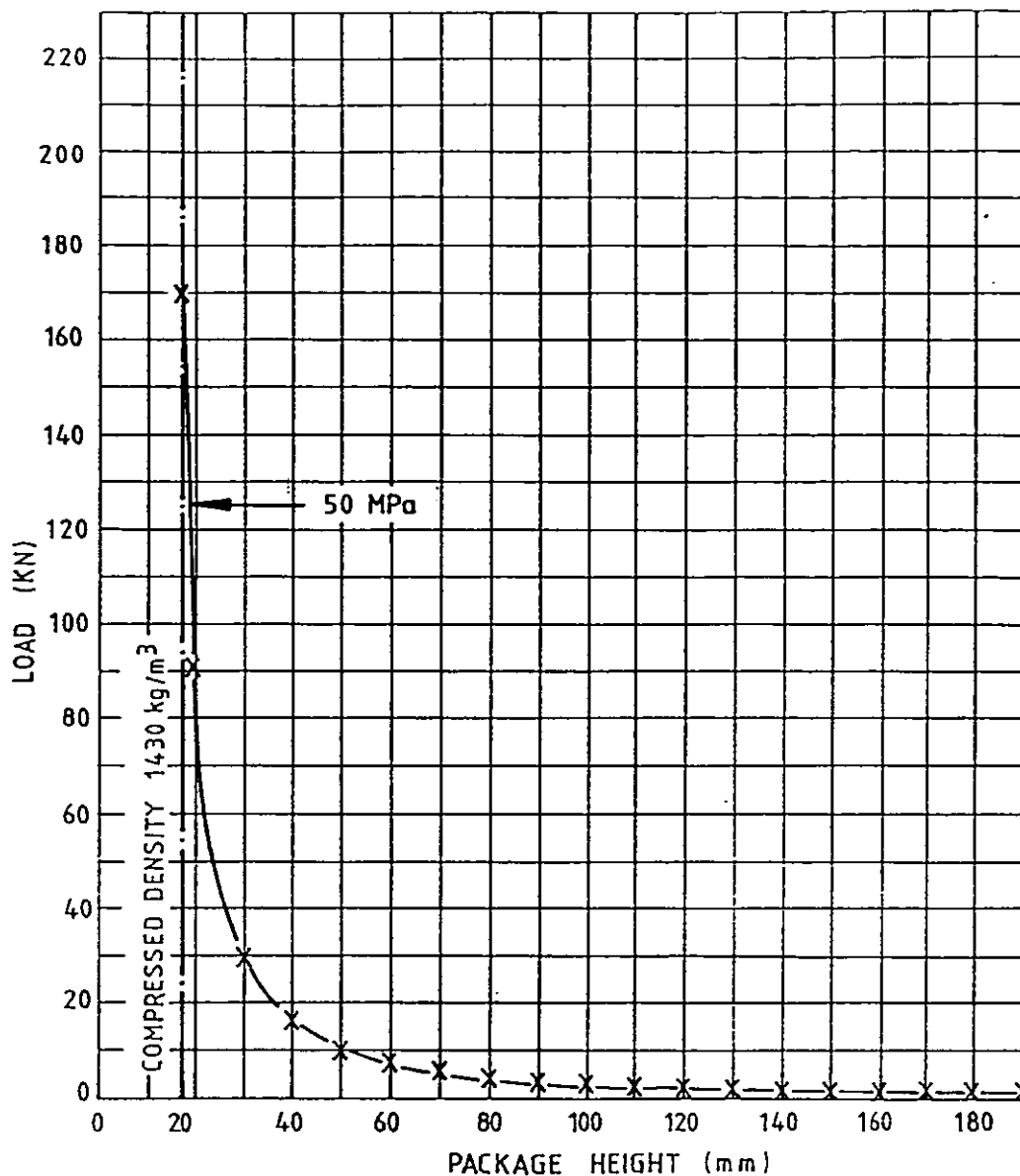

BRIQUETTE MASS 65g  
 CROSS SECTION 50.8mm x 50.8mm  
 (NO CHAMFERS)

- (i) BRIQUETTE TO GIVEN DENSITY      (ii) BRIQUETTE TO GIVEN PRESSURE  
1430 kg/m<sup>3</sup>                                      50 MPa

WORK DONE = AREA UNDER  
 CURVE = 1548 J  
 REQUIRED RATE = 10 TONNES/hr  
 = 2.78 kg/s  
 ∴ POWER REQUIRED  
 =  $\frac{2.78}{0.065} \times 1548$   
 = 66.2 kW

WORK DONE = AREA UNDER  
 CURVE = 1418 J  
 ∴ POWER REQUIRED  
 =  $\frac{2.78}{0.065} \times 1418$   
 = 60.6 kW

Graph (ii) LOADING CURVES - TEST 12



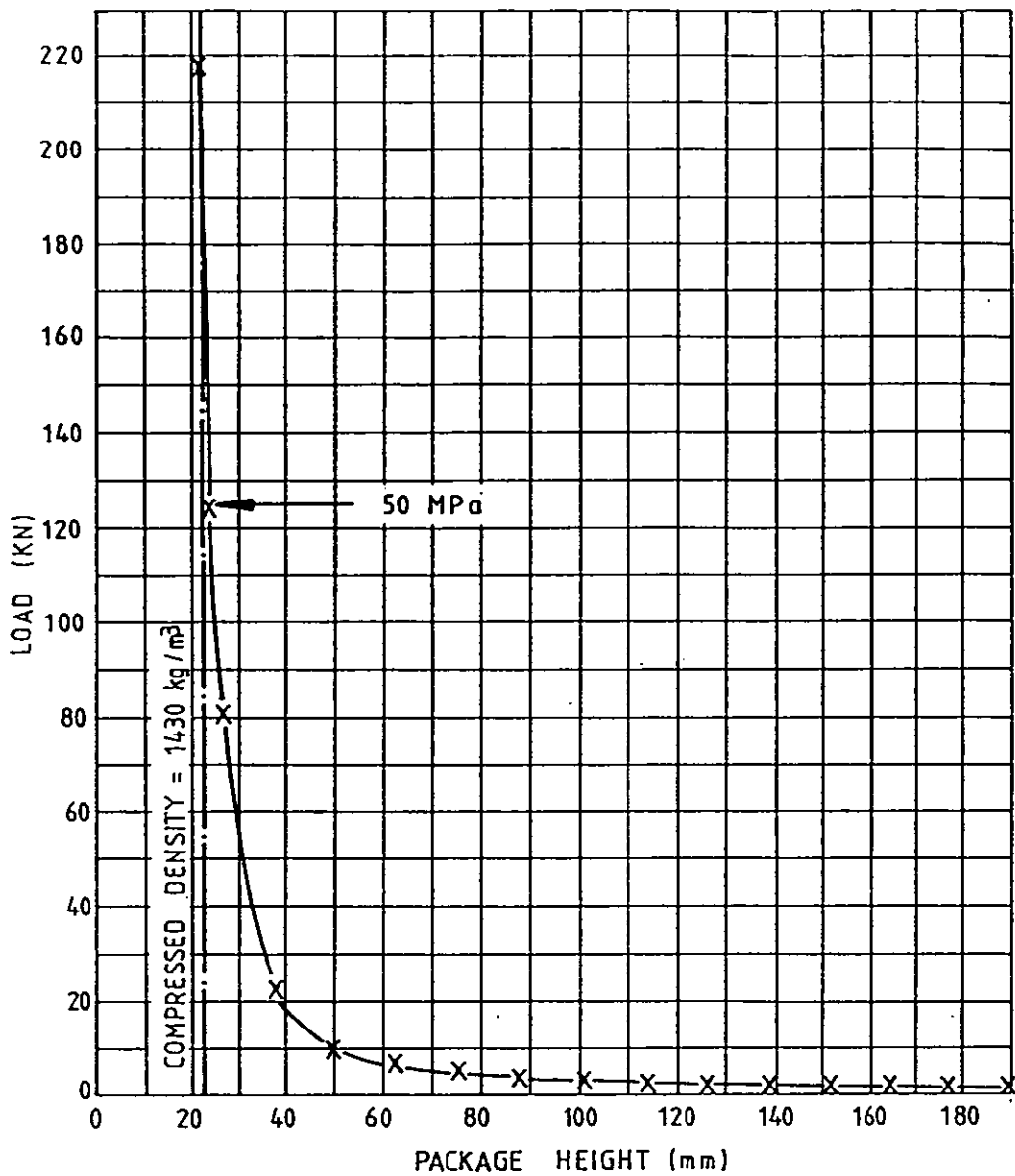

BRIQUETTE MASS 66g  
 CROSS SECTION 50.8 mm x 50.8 mm

SHAPE 'C'

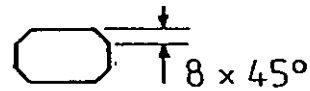

(i) BRIQUETTES TO GIVEN DENSITY  
1430 kg/m<sup>3</sup>

WORK DONE = AREA UNDER  
 CURVE = 1660 J  
 REQUIRED RATE = 10 TONNES/hr.  
 = 2.78 kg/s

∴ POWER REQ'D  
 =  $\frac{2.78}{0.066} \times 1660$   
 = 69.9 kW

(ii) BRIQUETTES TO GIVE PRESSURE  
50 MPa

WORK DONE = AREA UNDER  
 CURVE = 1415 J  
 ∴ POWER REQ'D =  $\frac{2.78}{0.066} \times 1415$   
 = 59.6 kW

Graph (iii) LOADING CURVE – TEST 14

APPENDIX II

The use of Numerical Analysis as an aid to Die  
Shape Optimisation

## APPENDIX II - NUMERICAL METHODS APPLIED TO DIE OPTIMISATION

A series of NAG optimisation subroutines were readily available on the Mainframe "Prime" computer in the University and a Fortran program was written incorporating the appropriate NAG routine in an attempt to identify optimum die dimensions.

The routine selected (EO4 JAF) was a quasi-Newtonian algorithm for finding the minimum of a function  $F(x_1, x_2, \dots, x_n)$  subject to fixed upper and lower bounds on independent variables  $x_1, x_2, \dots, x_n$ . This algorithm could also be used for maximising a given function since a maximisation problem may be transformed into minimisation simply by multiplying the function by -1.

Perhaps the greatest difficulty in applying this type of numerical analysis to a real problem is to establish, in mathematical terms, which parameter(s) should be maximised. In the case of die optimisation, it would be impossible, for example, to express mathematically the subjective requirements that briquette shape should provide attractive appearance and the highest possible durability. Fortunately, experimental results consistently indicated that these two factors tend to go hand in hand and seem to be, at least partly, connected with the size of the chamfers in the dies when considering the experimentally derived shape described as style 'C'.

Other factors which would need to be kept in mind whilst interpreting the results of the optimisation process were:-

- o It would be undesirable to have very large sheared faces because these parts of a briquette are usually the roughest and least consistent.

- o All the principal dimensions (length, width and relaxed height) are mutually dependent and should always be considered together. It would be unlikely that a good solution would result if one of these dimensions was widely different from the others.
  
- o The chamfer depth should be considered in relation to the principal dimensions and not as an absolute value.

### THE CONTROL PARAMETERS

As it would be virtually impossible to apply rigorous mathematical modelling to satisfy a list of largely subjective requirements, the problem had to be simplified and the results could, therefore be used only as guidelines for judging the optimum design as a supplement to the laboratory work. It was resolved to maximise the chamfer depth, (d) for varying briquette length (l), width (w), the angle the chamfers make with the base of the die ( $\theta$ ), and the die clearance or nip (n).

#### (i) Die Length (l)

As stated in clause 8.1.2, compression is assumed to take place in the vertical direction only, with no compression or extension of the swath as it passes through the machine. Assuming a constant swath, this implies that the quantity of compressed material in the briquette is directly proportional to the die length and if all briquettes are compressed to the same density, then the volume of the cavity would also be in direct proportion to the die length.

Taking the capacity of a field machine to be 10 Tonne/hour when travelling at 5 m.p.h., then the mass of straw per unit length must be:

$$10 \times 1000/5 \times 1609 = 1.24 \text{ kg/metre of swath}$$

If there is to be no longitudinal compression then the specific mass of briquettes under compression must also be 1.24 kg/m.

Taking the compressed density of straw as 1350 kg/m<sup>3</sup>, the die cavity volume in the fully closed position must be:

$$V = \frac{1.24 \text{ l}}{1350} \times 10^6 \dots\dots \text{Dimensions in millimetres}$$

i.e. V = 918.5 l .....(1)

(ii) Height Considerations (h)

The major restriction on the closed height of the dies was the absolute requirement for a step between adjacent briquettes to separate the compressed mass into individual packages. Empirical results suggested that a step ratio, (S<sub>r</sub>) of 0.70 was desirable and that 0.65 should be taken as an absolute minimum.

At this stage of the investigation, it had been specified that the rotating discs should have a finite radial clearance between the highest point of the dies on each disc. Initially in the analysis, this clearance (n), was allowed to vary, but it was later given a minimum practicable value (0.5 mm) as it had become clear that large chamfers would only be available with a minimal nip distance.

COMPRESSED CONDITION

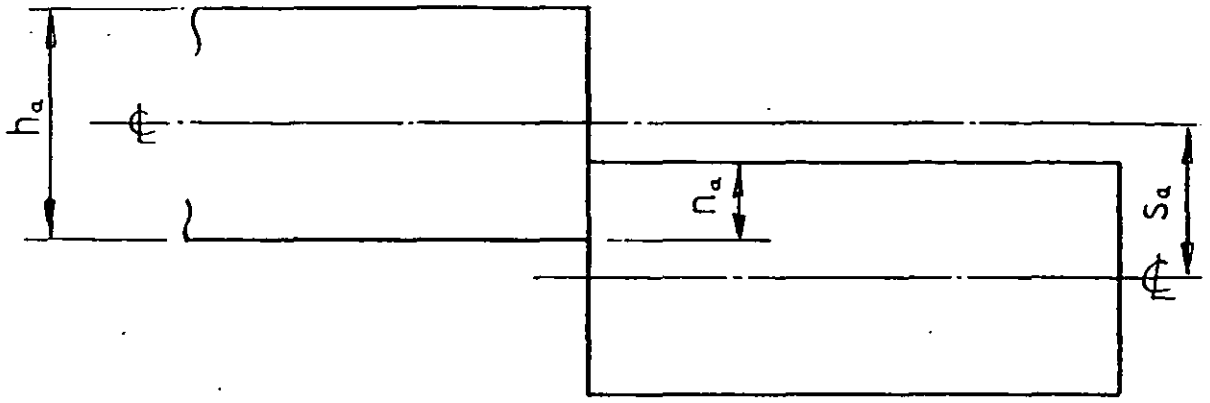

(a) Without Chamfers

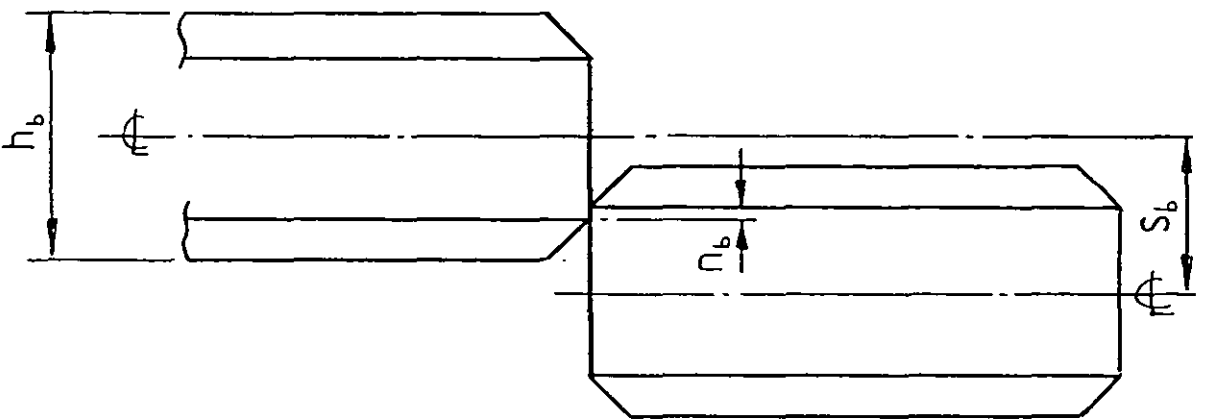

(b) With Chamfers

$$S_a = \frac{S_a}{h_a} = \frac{S_b}{h_b}$$

Constant Volume

Figure A2.1 Comparison of Square Edged and Chamfered Dies showing the Limitation in Chamfer Depth due to the reduction in the Nip Clearance.

Figure A2.1 graphically illustrates how the addition of chamfers to a rectangular die drastically reduce the available clearance. If the step ratio and the cavity volume are held constant, the small increase in overall height which result from the addition of chamfers do little to offset the closing of the die clearance due to the die wall being automatically raised by the full depth of the chamfer.

(iii) Width (w)

Since the width of the briquette would not be expected to change significantly in the final stage compactor, it would be dependent upon the width of pre-compacted mass fed into the discs. As the in-feed width is decreased, then the power consumption would grow and the forces on the bearings of the precompactor would increase dramatically. A choice has to be made on a width which would conform to the original conception of a substantial final stage coupled to a relatively lightly loaded pre-compaction stage. The only other restriction on width is given by the need to produce a conveniently sized package for bulk handling.

(iv) Chamfer Angle ( $\theta$ )

For a given volume of material and a given chamfer depth (d) steeper chamfer angles would reduce the overall height of the package and hence, in order to maintain sufficient die clearance, the step height would need to be reduced. Conversely it follows that a shallow chamfer angle would be desirable for the chamfer depth to be maximised. In the practical situation, however, where the briquette would be of a finite width (w) the limit to which the angle may be decreased is given by:

$$\theta = \text{Tan}^{-1} \frac{2d}{w}$$

In this case the two chamfers would meet at the centre of the top surface of the briquette such that the resulting shape would no longer be the fourteen sided polygon conceived in the preceding experimental work (chart 1, Appendix I). Consequently, in the numerical analysis the chamfer angle was only allowed to vary between arbitrarily chosen limits  $30^\circ$  and  $60^\circ$ .

#### THE MAXIMISATION PROBLEM

In the application of the maximisation routine to the problem, it was necessary to develop a relationship between  $d$  and the independent variables  $w$ ,  $l$  and  $\theta$ . The equation would also contain terms in  $n$  and the step ratio,  $S_r$ .

With reference to figure A2.2:

$$V = w l h_1 + 2V_1 \quad (2)$$

$$V_1 = d [w_1 l_1 + c(w_1 + l_1) + \frac{4}{3} c^2] \quad (3)$$

but  $l_1 = l - 2c$

and  $w_1 = w - 2c$  by definition

therefore  $V_1 = d [wl - c(w + l) + \frac{4}{3} c^2] \quad (4)$

but  $c = \frac{d}{\tan \theta}$  by definition

therefore  $V_1 = d [wl - \frac{d}{\tan \theta} (w + l) + \frac{4}{3} c^2] \quad (5)$



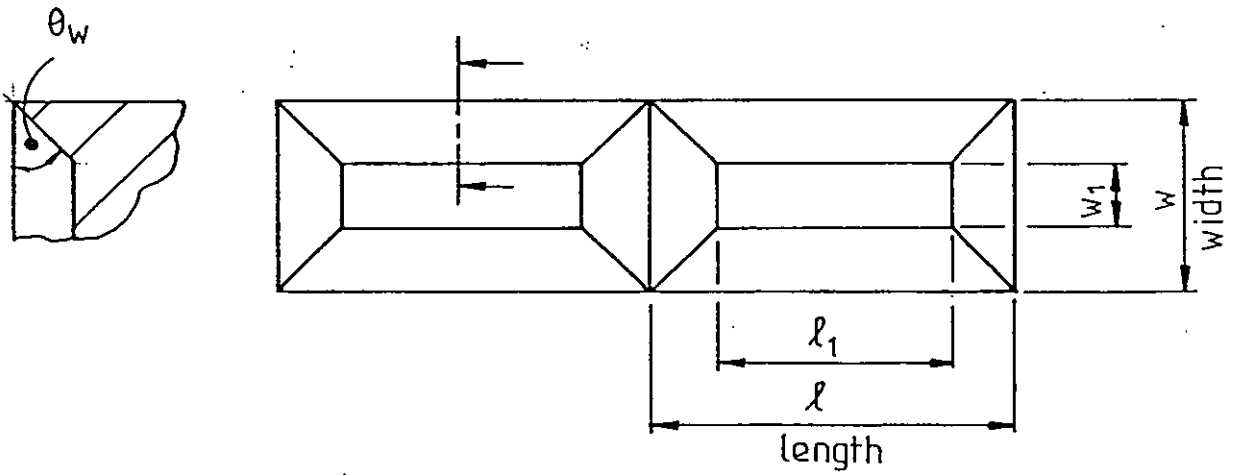
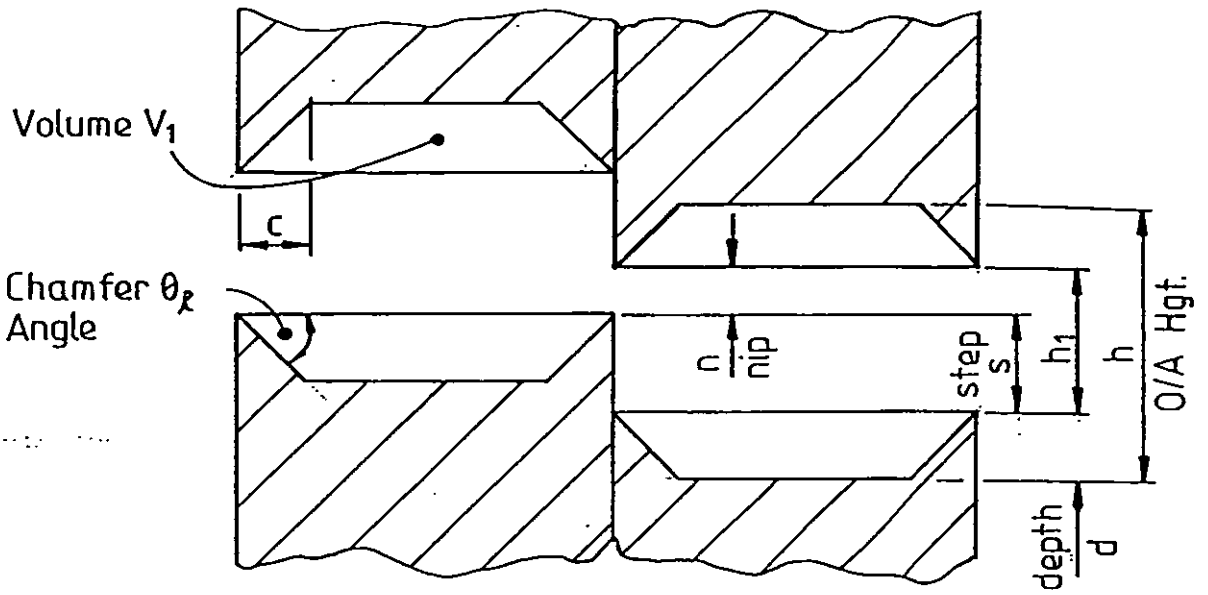

ALL DIES IDENTICAL  
 LET  $\theta_r = \theta_w = \theta$   
 $V =$  total cavity volume

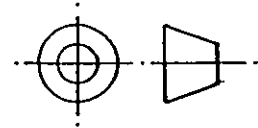

Figure A2.2 Die Nomenclature

Also, referring to the figure A2.2:

$$h_1 = h - 2d \quad (6)$$

and  $h_1 = S + n$  where  $S = S_r h$

therefore  $h_1 = S_r h + n$  (7)

Combining equations (6) and (7)

$$h_1 = \frac{n + 2d S_r}{1 - S_r} \quad (8)$$

Substituting for  $V$ ,  $V_1$  and  $h_1$  in (2)

$$918.5 l = wl \left( \frac{n + 2d S_r}{1 - S_r} \right) + 2d \left[ wl - \frac{d}{\tan \theta} (w + 1) + \frac{4}{3} \frac{d^2}{\tan^2 \theta} \right]$$

collecting terms in "d" and rearranging gives:-

$$d^3 \left( \frac{8}{3 \tan^2 \theta} \right) - d^2 \left( \frac{2(1+w)}{\tan \theta} \right) + d \left( \frac{2wl}{1-S_r} \right) + l \left[ \frac{nw - 918.5(1 - S_r)}{(1 - S_r)} \right] = 0$$

re-writing gives equation (9):-

$$d^3 - d^2 \left[ \frac{3}{4} \tan \theta (1+w) \right] + d \left[ \frac{3wl \tan^2 \theta}{4(1-S_r)} \right] + \left[ \frac{3 \tan^2 \theta (nw l - 918.5 l (1-S_r))}{8(1-S_r)} \right] = 0$$

this equation may be represented by

$$d^3 + pd^2 + qd + r = 0 \quad (10)$$

where  $p = - \frac{3}{4} \tan \theta (1 + w)$

$$q = \frac{3}{4} \frac{wl \tan^2 \theta}{(1 - S_r)}$$

and  $r = \frac{3}{8} \frac{\tan^2 \theta (nw l - 918.5 l (1 - S_r))}{(1 - S_r)}$

In order to apply Cardan's solution to a cubic equation, the equation is required to be in the form:-

$$d_1^3 + a d_1 + b = 0$$

Thence, let

$$d_1 = d + \frac{P}{3}$$

or

$$d = d_1 - \frac{P}{3} \tag{11}$$

Substitute in equation (10)

$$(d_1 - \frac{P}{3})^3 + p(d_1 - \frac{P}{3})^2 + q(d_1 - \frac{P}{3}) + r = 0$$

expanding this gives:-

$$d_1^3 + d_1 \left[ \frac{3q - p^2}{3} \right] + \left[ \frac{2p^3 - 9qp + 27r}{27} \right] = 0$$

or

$$d_1^3 + a d_1 + b = 0 \tag{12}$$

where

$$a = \frac{3q - p^2}{3} \quad \text{and} \quad b = \frac{2p^3 - 9qp + 27r}{27}$$

---

Now, using Cardan's theorem, solve equation (12) for  $d_1$

$$d_1 = \left\{ -\frac{b}{2} + \sqrt{\frac{a^3}{27} + \frac{b^2}{4}} \right\}^{1/3} + \left\{ -\frac{b}{2} - \sqrt{\frac{a^3}{27} + \frac{b^2}{4}} \right\}^{1/3}$$

$$\text{or } d_1 = \left\{ SQ - \frac{b}{2} \right\}^{1/3} - \left\{ SQ + \frac{b}{2} \right\}^{1/3}$$

where

$$SQ = \sqrt{\frac{a^3}{27} + \frac{b^2}{4}}$$

---

Summarising:-

$$d = d_1 - \frac{P}{3}$$

where  $d_1 = \left\{ SQ - \frac{b}{2} \right\}^{1/3} - \left\{ SQ + \frac{b}{2} \right\}^{1/3}$

where  $SQ = \sqrt{\frac{a^3}{27} + \frac{b^2}{4}}$

and  $a = \frac{3q - p^2}{3}$  and  $b = \frac{2p^3 - 9qp + 27r}{27}$

also  $p = -\frac{3}{4} \tan \theta (1 + w)$

$$q = \frac{3}{4} \frac{wl \tan^2 \theta}{(1 - S_r)}$$

and  $r = \frac{3}{8} \frac{\tan^2 \theta (nwl - 918.5 l(1 - S_r))}{(1 - S_r)}$

---

Equation (11) is, an expression for d in terms of w, l,  $\theta$ , n and  $S_r$ , the independent variables, and is, therefore in a suitable form to apply the maximisation routine.

Finite limits were ascribed to the independent variables, consistent with the notational sizes of the component parts. The computer program calculated the maximum value of d from equation (11) for any value of the five independent variables within these limits.

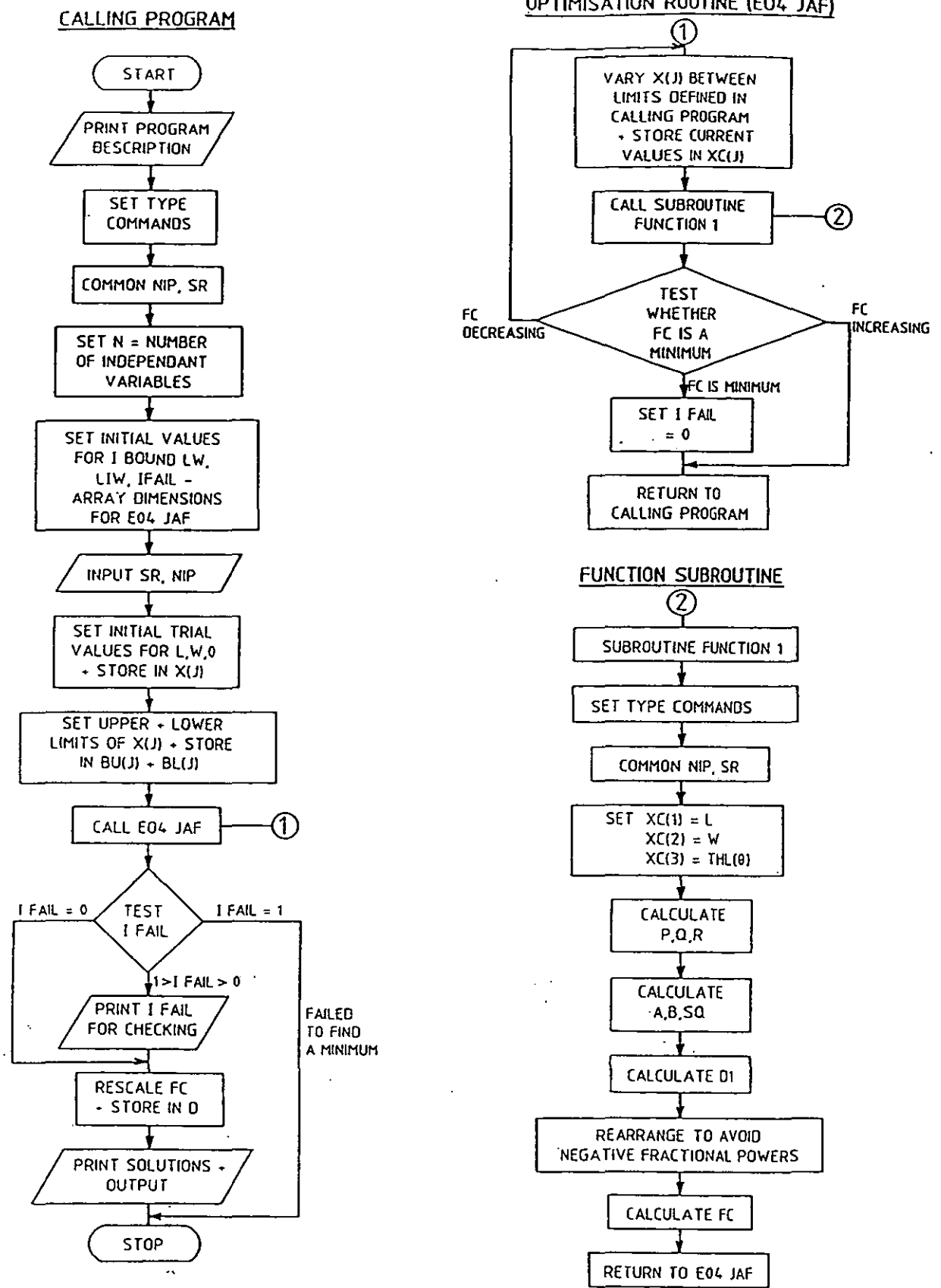

FLOW CHART SHOWING OPERATING PRINCIPLES OF COMPUTER OPTIMISATION

Figure A2.3

Figure A2.3 is a generalised flow chart for the maximisation program showing the usage of the NAG library package (E04 JAF).

NOTE: The program and foregoing analysis outlined here are, in fact, just one of several attempts to find a combination of the many variables which would allow deep chamfers within the experimentally derived constraints.

#### CONCLUSIONS FROM THE MATHEMATICAL OPTIMISATION

The results of the optimisation procedure were rather disappointing. Instead of identifying some intermediate combination of values for the independent variables which allowed the maximum chamfer depth, the solutions showed only a simple dependence. In every case where the length, width and chamfer angle were varied between notational finite limits for given values of 'Step Ratio' and 'Nip', the iterative process tended towards the minimum allowable values of length and width and the shallowest acceptable chamfer angle; there being no complex combination of the various shape parameters which allow for an increased chamfer depth.

Hence to obtain the largest possible chamfer depth the requirements are:

- (i) Minimum acceptable step ratio for shearing;
- (ii) Minimum die length;
- (iii) Minimum die width; and
- (iv) Shallowest chamfer angle.

Absolute minimum values of width and length occur when;

$$w = l = 2 \times \text{chamfer width}$$

or:

$$w = l = 2d \text{ for } 45^\circ \text{ chamfers}$$

The limit giving the following approximate shape (assuming  $S_r = 0.7$ ):

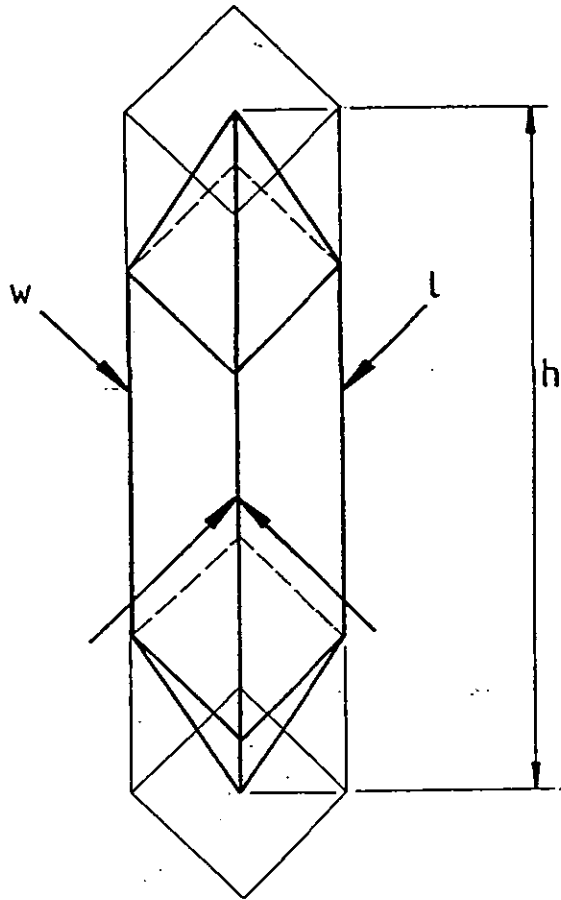

Figure A2.4

where  $w = l = 20 \text{ mm}$

chamfers are approx.  $10 \text{ mm} \times 45^\circ$ .

The overall compressed height ( $h$ ) of a package such as this would be 65 mm from apex to apex resulting in a relaxed package of approx.  $20 \times 20 \times 143 \text{ mm}$  (allowing for a relaxation factor of 2.2). The package would have two long slim sheared faces likely to be of rough appearance. Hence this shape had to be dismissed as unsuitable in practical terms.

Some interesting information did, however, emerge from the numerical analysis. In particular, the relative importance of variations in each of the individual dimensions could be highlighted. Graph A2.5 shows the effects of changing width and length on maximum size of  $45^\circ$  chamfer obtainable for  $S_r = 0.7$ .

The length of the briquette has a negligible effect on the chamfer depth; from graph A2.5 for a given die width of, say 50 mm, changing the die length from 30 to 80 mm gives a chamfer depth increase of only 0.063 mm, with intermediate die lengths causing a proportionately smaller change. These differences are of a magnitude such that manufacturing tolerances would make them imperceptible; hence there is freedom to choose whatever convenient die length matches the other parameters.

As the appearance of the briquette is one of the factors under investigation it is suggested that the briquettes be reasonably symmetrical, preferably with the length equal to the width, implying that the shape likely to give the best briquette appearance would relax into a cube with chamfered corners. The depth of the chamfers would then be limited by the shearing criteria.

With a square section die being decided upon rather than a rectangular shape, it became clear that the chamfers across the width of the die and those across the length would have the same angle. Table A2.6 shows computed values of maximum chamfer depth with varying chamfer angle for 50.8 mm square dies ( $S_r = 0.7$ ). The results give the computed effect of changing the chamfer angle upon maximum allowable chamfer depth. This effect was shown to be so small that there would be little reason to deviate from the  $45^\circ$  chamfers used in the preceding experimental work.



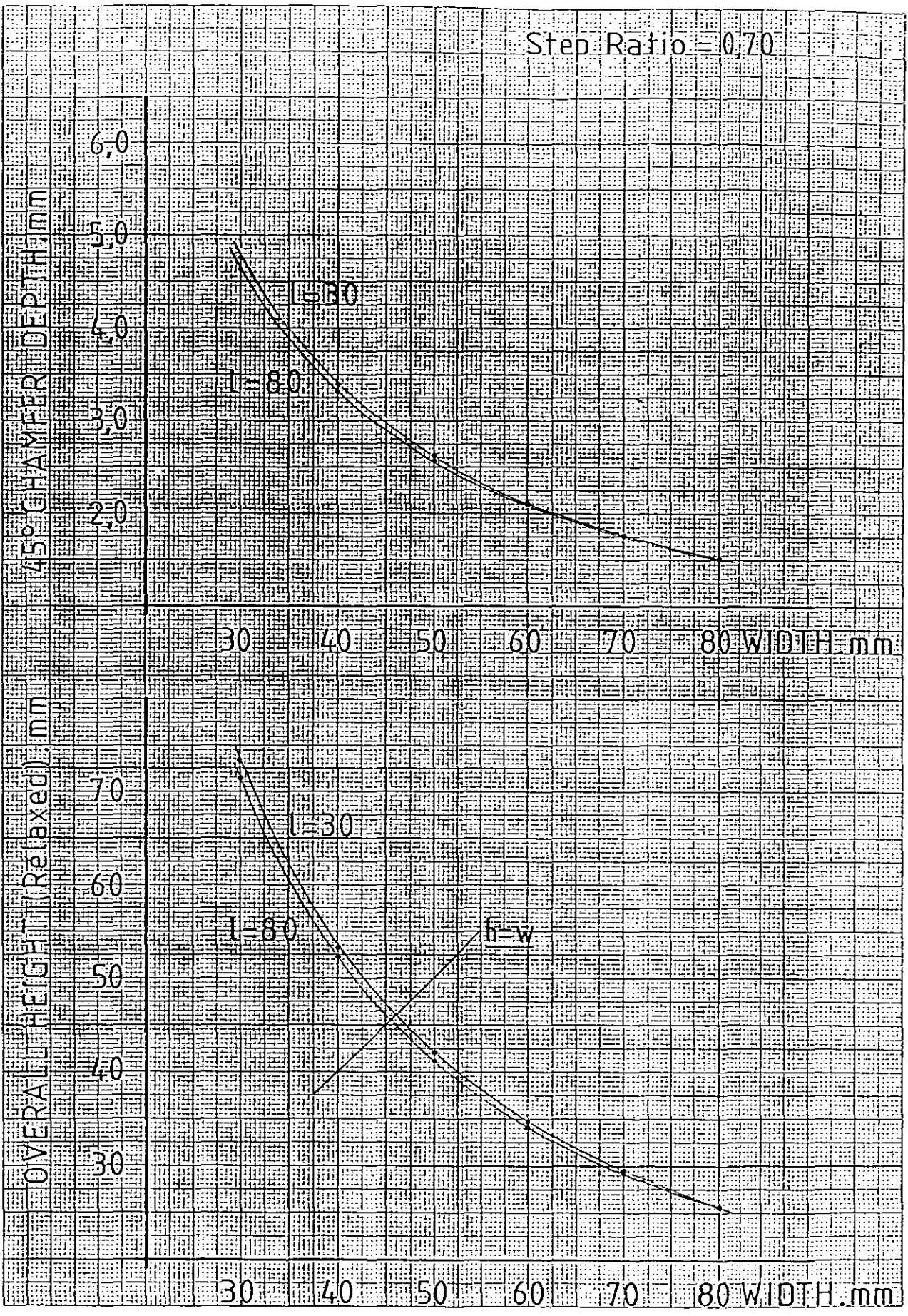

Graph A2.5 Inter-relationship of the Die Dimensions.

Chamfer angle $\theta$	Max. allowable chamfer depth (d)	Overall compressed height (h)
60	2.53	18.41
45	2.55	18.61
30	2.60	18.98
15	2.75	20.02
7 (limit)	3.07	22.18

Table A2.6 The Effect of varying the Chamfer Angle.

APPENDIX III

Comparison of the Velocity Profiles of the Crank Press  
with the Conical and Radial Disc Systems

APPENDIX III

To compare the closure velocity of the Rhodes press (Nottingham Polytechnic) with that of the prototype conical disc compactor and contrast the results with the alternative Radial Disc system.

1. THE CRANK PRESS

The press will achieve its maximum velocity when set to run at:-

Maximum Cyclic Speed (verified) = 88 strokes per minute

Maximum Stroke Length (verified) = 6 inches.

The press operates on the slider-crank principle and the connecting rod was measured at  $l = 559$  mm.

At maximum stroke (6") the crank radius,  $r = 76.2$  mm.

Let  $x$  be the displacement of the ram from Bottom Dead Centre position.

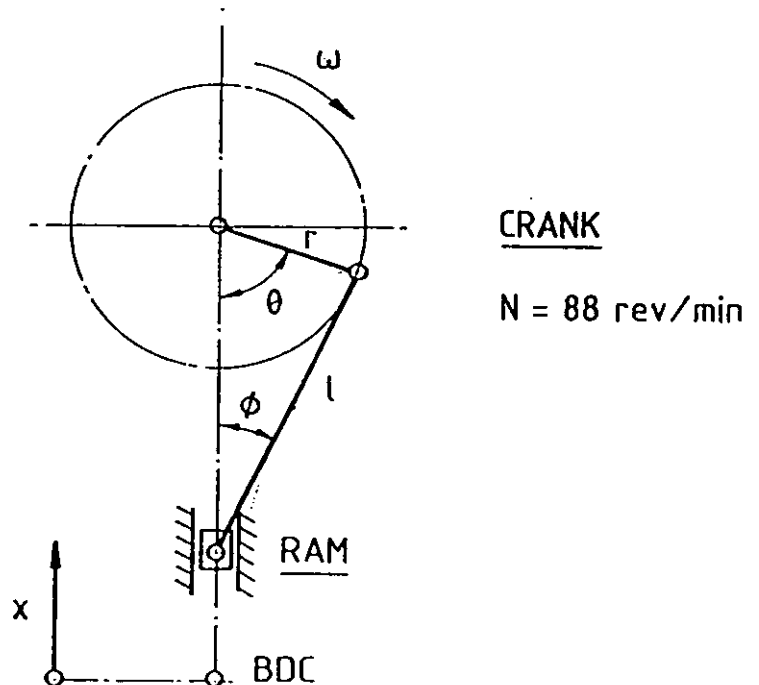

Figure A3.1 Crank Press.

Then

$$x = (r + l) - (r \cos \theta + l \cos \phi)$$

Also

$$r \sin \theta = l \sin \phi$$

$$\begin{aligned} \text{Therefore } \sin \phi &= \frac{r}{l} \sin \theta \\ &= \frac{\sin \theta}{a} \end{aligned}$$

$$\text{Where } a = \frac{l}{r}$$

$$\begin{aligned} \text{Therefore } \cos \phi &= \sqrt{1 - \left(\frac{\sin \theta}{a}\right)^2} \\ &= 1 - \frac{\sin^2 \theta}{2a^2} - \frac{\sin^4 \theta}{8a^4} - \frac{\sin^6 \theta}{16a^6} \dots \dots \text{ etc.} \end{aligned}$$

$$\text{or } \cos \phi = 1 - \frac{\sin^2 \theta}{2a^2} \quad \text{approximately, since } \frac{1}{a} \text{ is small}$$

$$\text{Therefore } x = r(1 - \cos \theta) + \frac{l \sin^2 \theta}{2a^2}$$

$$\text{Therefore velocity of ram, } v = \frac{dx}{dt} = \left(r \sin \theta + \frac{l \sin 2\theta}{2a^2}\right) \frac{d\theta}{dt}$$

$$\text{Therefore } v = \omega r \left(\sin \theta + \frac{\sin 2\theta}{2a}\right)$$

---

## 2. CONICAL DISC COMPACTOR

Assuming that the linear speed of the machine is 5 mph (2.24 m/s) and that the straw swath suffers no compression or extension in the longitudinal direction then:-

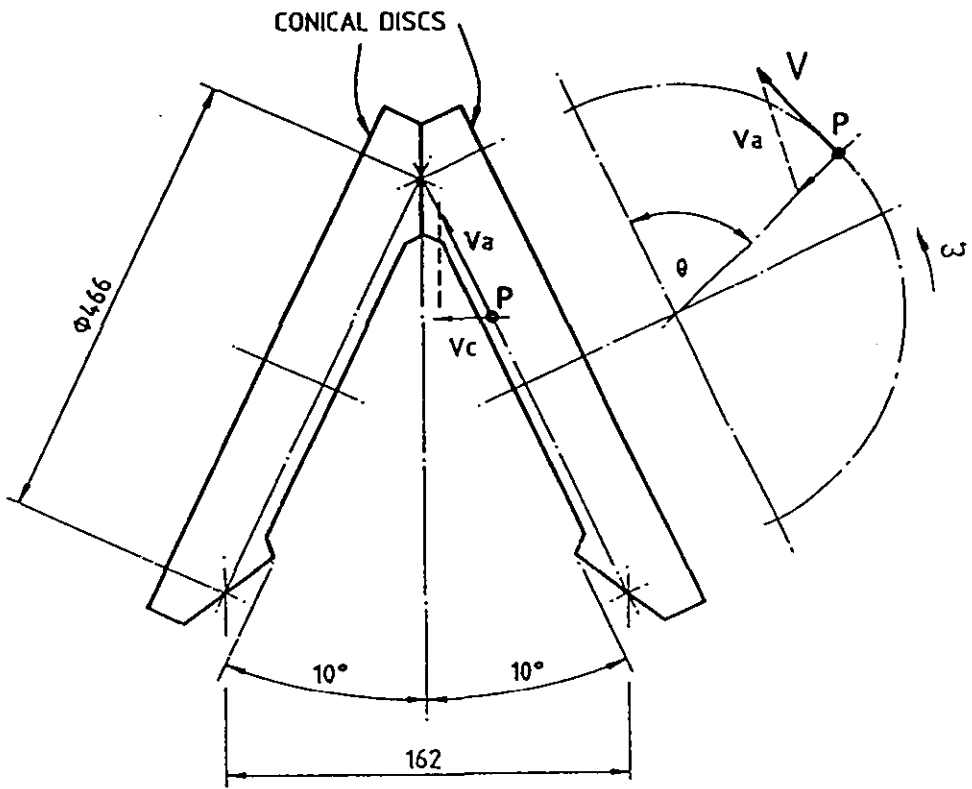

Figure A3.2 Conical Discs.

Consider any point,  $P$  in the centre of the die ring of one disc.  
 Let the component of the edge velocity,  $V$  tending towards the nip point be  $v_a$  (see fig. A3.2).

where  $v_a = V \sin \theta$ .

But the coaxial closing velocity of the disc at this point,  $v_c$  is given by:

$$v_c = v_a \sin 10^\circ$$

Therefore the closing velocity of each disc is

$$v_c = V \sin 10^\circ \sin \theta.$$

Hence the total closing velocity is

$$v = 2 V \sin 10^\circ \sin \theta$$

giving

$$v = 778 \sin \theta \text{ mm/s. (sinusoidal).}$$

---

NOTE: The velocity profiles of the crank press and the conical disc system are compared graphically in Figure 10.2.1a.

3. TO COMPARE THE CLOSING VELOCITY OF A SIMILAR RADIAL DISC PAIR

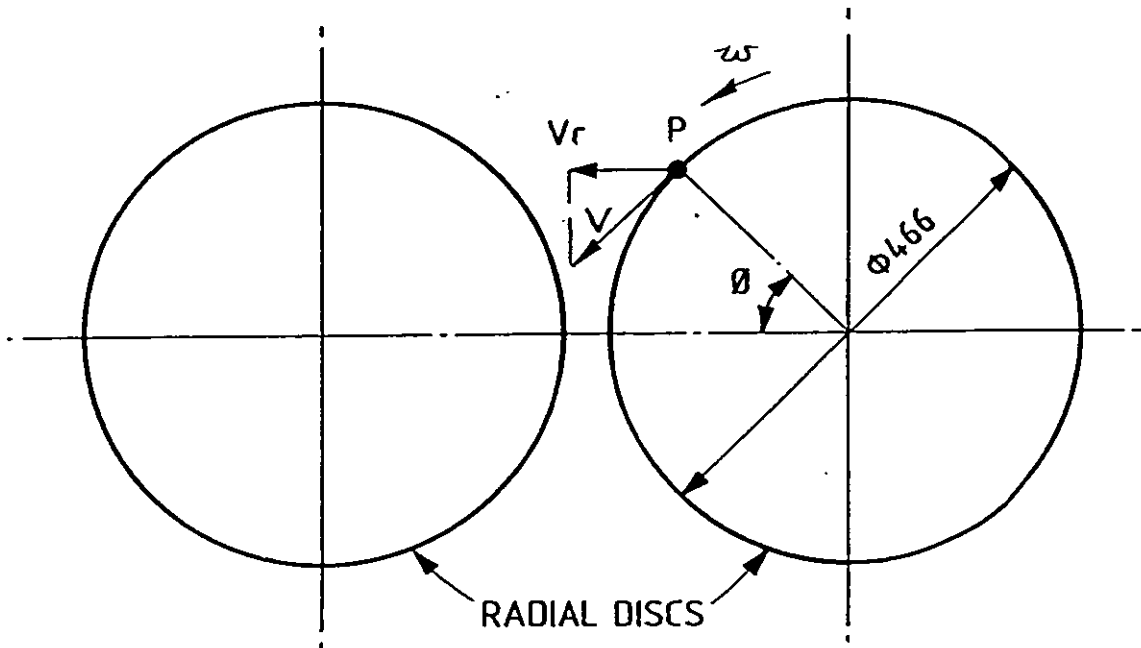

Figure A3.3 Radial Discs

Assuming the same disc diameter and the same forward speed and, again considering point  $P$  on the die at angle  $\theta$  from the nip, we have:

The closing velocity of each disc is

$$v_r = V \sin \theta.$$

Hence, the compaction velocity for the radial system is

$$v = 2 V \sin \theta$$



so, comparing this with the closure velocity of the conical disc system

$$v_r / v_c = 1 / \sin 10^\circ$$

i.e. the ratio of the closing velocity of the two concepts (at any point on the periphery which is  $\theta^\circ$  from the nip point) is given by the sine of the half angle of inclination of the conical discs. For the chosen angle, the conical discs compact the straw with only 17% of the velocity of the equivalent radial pair.

APPENDIX IV

Forces in the Second Stage Converging Chain  
System of the Pre-compactor Rig

APPENDIX IV

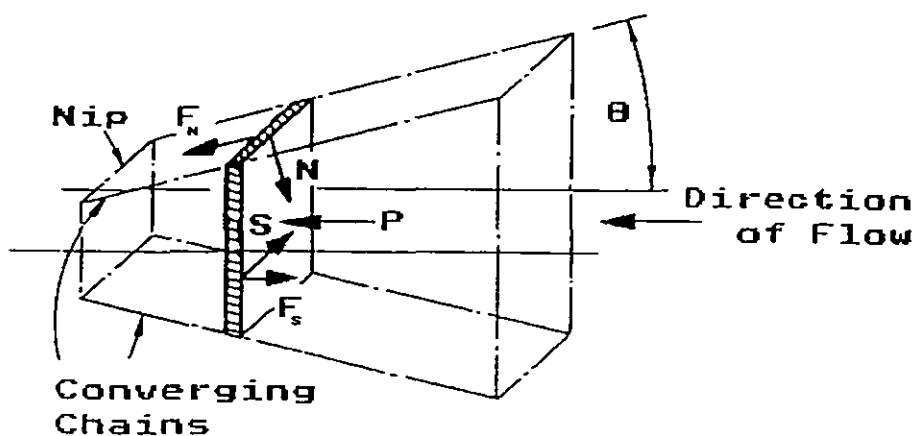

FIGURE 1 Forces in the System

Consider the forces acting on an element of the straw. Forces on one symmetrical half of the element only are shown in Figure 1.

- Definition:
- $P$  = Assisting force supplied by the first stage.
  - $N$  = Normal reaction of chains
  - $S$  = Normal reaction of stationary side plates.
  - $F_N$  = Carrying friction force provided by moving mains.
  - $F_S$  = Resisting friction force on straw from side plates.
  - $\mu_C$  = Coefficient of friction on chains.
  - $\mu_S$  = Coefficient of friction on side plates.

Resolving forces horizontally:- for equilibrium

$$2 F_N \cos \theta + P = 2(F_S + N \sin \theta)$$

but  $F_N = \mu_C N$  and  $F_S = \mu_S S$

$$\Rightarrow \mu_C N \cos \theta + P/2 = \mu_S S + N \sin \theta$$

The flow condition is given by:

$$N (\mu_C \cos \theta - \sin \theta) > \mu_S S - P/2 \quad (1)$$

Taking P to be small (Found experimentally to be 152 Newtons for the demonstration rig). Then, if the side panels move with the straw and therefore, present no frictional resistance.

The flow condition can be written:

$$N (\mu_C \cos \theta - \sin \theta) > 0 \quad (2)$$

Hence,  $\mu_C \cos \theta > \sin \theta$

or  $\mu_C > \tan \theta \quad (3)$

In the case of the demonstration rig, the angle of convergence is  $30^\circ$  so  $\theta = 15^\circ$ .

Hence,  $\mu_C > \tan 15^\circ$

or  $\mu_C > 0.26$

If static side panels are to be introduced, then the frictional drag term,  $\mu_s S$  in equation (1) will become important.

At the start of the second stage, the side force,  $S$ , will be approximately equal to the conveyer load at the end of the first stage. At this position the pressure on the second stage conveyers will be very small so that moving side plates will be essential (see Graph 11.1). As the chains converge, the straw pressure will increase. The normal force,  $N$ , on the conveyers will be higher towards the nip point but the value of  $S$  will also increase. In his paper, Mewes (Ref. 34) suggests that the lateral side wall pressure will be about half the applied pressure from the conveyers due to the effect of Poissons Ratio.

By designing conveyers with a high coefficient of friction, it may be possible to accept low friction static side panels in the region of the nip. To establish the extent of these panels would require further analytical investigation.

#### Experimental Determination of the Friction Coefficient:

A simple conventional laboratory friction experiment with a straw briquette sliding on an inclined plane gave the coefficient as 0.17, however, under the Author's supervision, final year undergraduate, Burrage (Ref. 56) found that the coefficient of friction between straw held under compression and the smooth dry steel surface containing it varied between 0.19 and 0.38. Not only was the effective coefficient found to vary in parts of the material batch but also a variance with package density was recorded. The recorded results were, however, of

doubtful integrity but if such a variation could be proved, then it would follow that the analysis of the forces in conveyed straw packages would acquire very considerable additional complexity.

APPENDIX V

Separating Forces acting upon Radial and Conical  
Disc Compactors

## APPENDIX V: ANALYSIS OF DISC SEPARATING FORCES

Analysis of the compaction of straw in a rolling mill differs fundamentally from conventional rolling practice (for metals) because of the different compressibilities of the working materials. Indeed, the primary purpose of the roll pass is altered: with straw, the purpose is to achieve an increase in density whilst with steel a reduction in section is required without a change in volume.

### Assumptions

(i) Straw within the compactor will suffer neither extension nor compression in the longitudinal flow direction. i.e. The material is fully compressible within the working density range.

(ii) The flow velocity at input is equal to the velocity at output.

(iii) The straw mass, on input, is consistent in both density and material content.

(iv) The reaction of the straw is proportional to its density and the non-linear pressure variation follows the relationship defined in section 7.5:

$$P = a \left( \frac{1}{\rho} - \frac{1}{\rho_0} \right)^{-b}$$

(v) The pressure is evenly distributed across the width of the compactor.



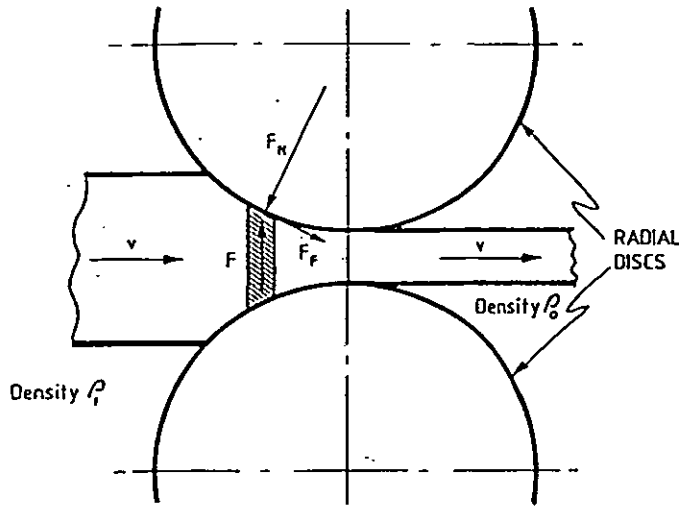

Figure A5.1

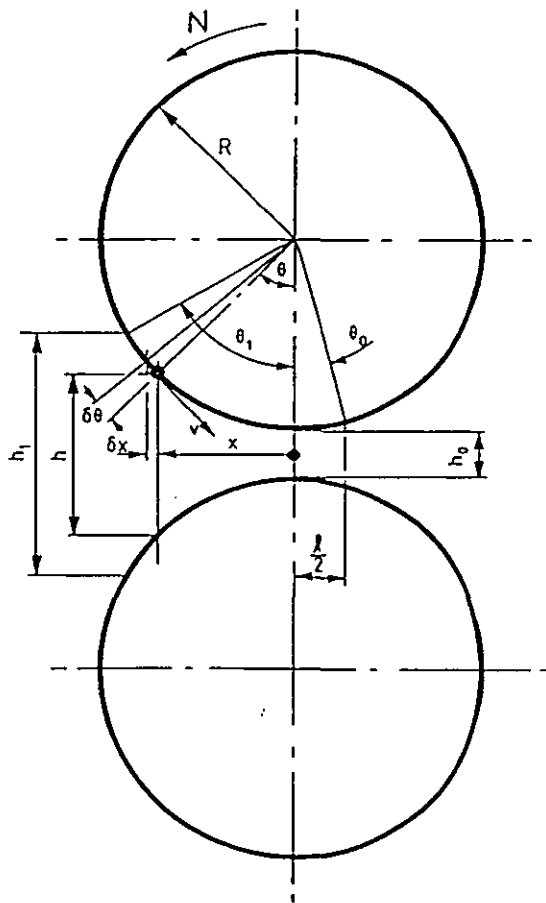

Figure A5.2

## 1. RADIAL DISCS

Referring to figure 5.1 and 5.2, consider an element of the swath,  $\delta x$  long.

Let the instantaneous pressure within the column of straw be  $P$ , then:-

$$F = Pw \delta x$$

but  $\delta x = \delta\theta \cos\theta$

$$\Rightarrow F = PwR \delta\theta \cos\theta \quad (1)$$

Now, from section 7.5 we have the empirical relationship

$$P = a \left( \frac{1}{\rho} - \frac{1}{\rho_0} \right)^{-b}$$

where  $a$ ,  $b$  and  $\rho_0$  are the material constants and the instantaneous density is given by

$$= \frac{m}{wh} \quad (m = \text{mass per unit length})$$

$$\Rightarrow P = a \left( \frac{wh}{m} - \frac{1}{\rho_0} \right)^{-b}$$

Substitute in equation (1)

$$F = awR \cos\theta \left( \frac{wh}{m} - \frac{1}{\rho_0} \right)^{-b} \delta\theta \quad (2)$$

but  $h = h_0 + 2R(1 - \cos\theta)$  by definition (3)

$$\Rightarrow F = awR \cos\theta \left[ \frac{w}{m}(h_0 + 2R(1 - \cos\theta)) - \frac{1}{\rho_0} \right]^{-b} \delta\theta$$

Expanding and collecting constants gives

$$F = awR \cos\theta \left[ \left( \frac{w}{m} (h_o + 2R) - \frac{1}{\rho_o} \right) - \frac{2wR}{m} \cos\theta \right]^{-b} \delta\theta$$

$$F = \frac{awR \cos\theta}{\left( \frac{w}{m} (h_o + 2R) - \frac{1}{\rho_o} - \frac{2wR}{m} \cos\theta \right)^b} \delta\theta$$

Integrating between limits  $\theta_1$  and  $\theta_o$  to give the resultant (total) force

$$F_t = \int_{\theta_o}^{\theta_1} \frac{K_1}{(K_2 - K_3 \cos\theta)} d\theta \quad (4)$$

where  $K_1 = awR$

$$K_2 = \frac{w}{m}(h_o + 2R) - \frac{1}{\rho_o}$$

and  $K_3 = \frac{2wR}{m}$

#### Integration Limits

It is realised that, although compaction has ceased at  $\theta = 0^\circ$ , there will be a significant reaction from the compressed straw immediately to the outlet side of the nip point. A simple laboratory experiment showed, however, that the magnitude of this relaxation force very soon became negligible as the dies draw apart. An estimation has therefore been made, based on the experimental readings.

It is assumed that a whole briquette, situated centrally at the nip, reacts symmetrically against the discs, however, relaxing packages further towards the outlet are not considered to exert a considerable reaction and are, therefore, disregarded.

i.e.  $\theta_0 = -\frac{1}{2R}$  since  $\theta_0$  is small.

Also, from equation (3) at the point of input

$$h_1 = h_0 + 2R (1 - \cos\theta_1)$$

so  $\theta_1 = \cos^{-1} \left[ 1 - \frac{(h_1 - h_0)}{2R} \right]$

As there is no obvious solution to the integral (4), it will be solved numerically using Simpson's Rule:

$$\int_{\theta_0}^{\theta_1} f(\theta) d\theta = \frac{i}{3} \{ f(\theta_0) + 4f(\theta_0 + i) + 2f(\theta_0 + 2i) + 4f(\theta_0 + 3i) + \dots + \dots + 4f(\theta_0 + (n-1)i) + f(\theta_1) \} + E$$

where the interval,  $i = \frac{\theta_1 - \theta_0}{n}$  and E is the error term.

For maximum flexibility and convenience the numerical values of the definite integral were entered into a computer using a commercial spreadsheet program, to perform the calculations. The spreadsheet enables an immediate read-out of the numerical result for any input value of R,  $h_0$  or m etc.

A typical print-out is given in figure A5.4 where the material constants were those derived from the regression analysis graph 8.2, based on rectangular die shapes to simplify the determination of the machine constants; see section A5(3).

2. CONICAL DISCS

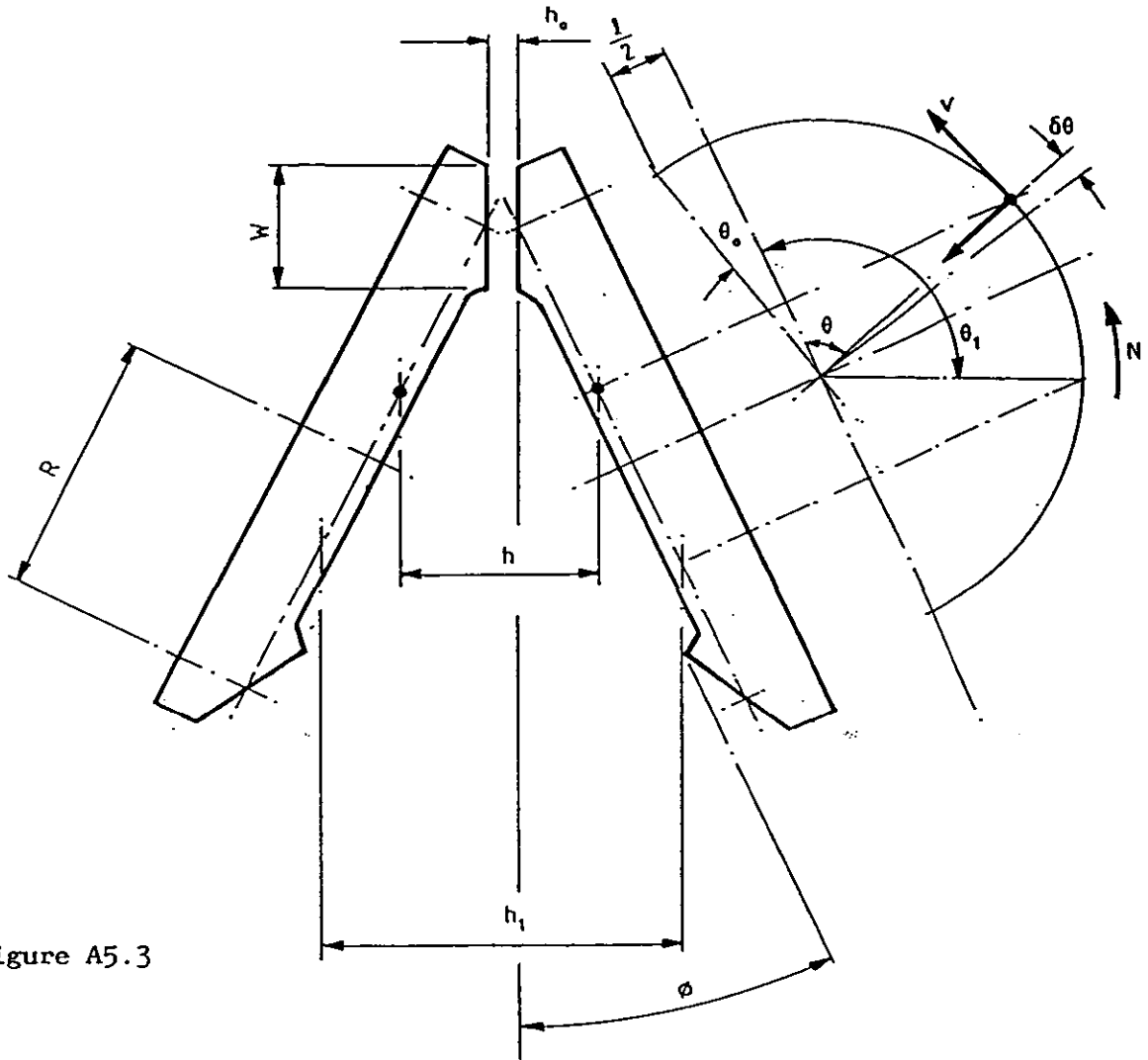

Figure A5.3

Referring to figure 5.3, consider an element of the swath

$$F = PwR \delta\theta \quad (\text{approximately}) \quad (1)$$

Now, as before

$$P = a \left( \frac{1}{\rho} - \frac{1}{\rho_0} \right)^{-b}$$

where  $a$ ,  $b$  and  $\rho_0$  are the material constants  
and the instantaneous density is given by

$$\rho = \frac{m}{wh} \quad (m = \text{mass per unit length})$$

$$\Rightarrow P = a \left( \frac{wh}{m} - \frac{1}{\rho_0} \right)^{-b}$$

Substitute in equation (1)

$$F = awR \cos\theta \left( \frac{wh}{m} - \frac{1}{\rho_0} \right)^{-b} \delta\theta \quad (2)$$

$$\text{but } h = h_0 + 2R(1 - \cos\theta) \sin\phi \quad \text{by definition } (3)$$

$$\Rightarrow F = awR \left[ \frac{w}{m} (h_0 + 2R \sin\phi (1 - \cos\theta)) - \frac{1}{\rho_0} \right]^{-b} \delta\theta$$

Expanding and collecting constants gives

$$F = awR \left[ \left( \frac{w}{m} (h_0 + 2R \sin\phi) - \frac{1}{\rho_0} \right) - \frac{2wR}{m} \sin\phi \cos\theta \right]^{-b} \delta\theta$$

$$F = \frac{awR}{\left[ \left( \frac{w}{m} (h_0 + 2R \sin\phi) - \frac{1}{\rho_0} \right) - \frac{2wR}{m} \sin\phi \cos\theta \right]^b} \delta\theta$$

Integrating between limits  $\theta_1$  and  $\theta_0$  to give the resultant (total)  
force

$$F_t = \int_{\theta_0}^{\theta_1} \frac{K_1}{(K_4 - K_5 \cos\theta)} d\theta \quad (4)$$

where  $K_1 = awR$

$$K_4 = \frac{w}{m} (h_o + 2R \sin\phi) - \frac{1}{\rho_o}$$

and  $K_5 = \frac{2wR}{m} \sin\phi$

### Integration Limits

As before, it is assumed that the total force will be the result of a complete briquette situated centrally about the nip point (see analysis for radial discs).

Hence;

i.e.  $\theta_o = -\frac{1}{2R}$  since  $\theta_o$  is small.

Also, from equation (3) at the point of input

$$h_1 = h_o + 2R (1 - \cos\theta_1) \sin\phi$$

so  $\theta_1 = \cos^{-1} \left[ 1 - \frac{(h_1 - h_o)}{2R \sin\phi} \right]$

As with the preceding analysis, no obvious solution to the integral was available, so Simpson's Rule was again used to evaluate the resultant force. A print-out of the appropriate spreadsheet appears in figure A5.5

In addition, the separating force and the corresponding compaction cycle times for both systems could be compared, for a wide range of machine dimensions, by manipulation of the two computer routines. Print-outs of such comparisons are given in figure A5.6.

### 3. DETERMINATION OF THE WORKING CONSTANTS (for the analysis).

From section 7.5

$$P = a \left( \frac{1}{\rho} - \frac{1}{\rho_0} \right)^{-b}$$

$$\Rightarrow \frac{1}{\rho} - \frac{1}{\rho_0} = \left( \frac{a}{P} \right)^{1/b}$$

$$\Rightarrow \frac{1}{\rho} = \left( \frac{a}{P} \right)^{1/b} + \frac{1}{\rho_0}$$

$$\text{or } \rho = \frac{1}{\left( \frac{a}{P} \right)^{1/b} + \frac{1}{\rho_0}}$$

Substituting material values from graph 8.2

$$a = 1.713 \times 10^{-4} \quad (\text{Pressure measured in MN/m}^2)$$

$$b = 1.52$$

$$\rho_0 = 2000 \text{ kg/m}^3$$

$$P = 50 \text{ MN/m}^2$$

$$\text{gives } \rho = \rho_c = 1327 \text{ kg/m}^3$$

Assuming a cavity cross section of 50.8 mm square and a mass flow rate of 1.24 kg/m (to comply with the specification).

$$\begin{aligned} h_0 &= \frac{m}{w\rho_c} \\ &= \frac{1.24 \times 10^{-4}}{50.8 \times 1327} = 18.4 \times 10^{-3} \end{aligned}$$

i.e. the compressed height is 18mm

An arbitrary value of 120mm was chosen for the input height ( $h_1$ )



INTEGRATION BY SIMPSON'S RULE

RADIAL DISC COMPACTOR

$$I = K1 \cos(\text{Theta})$$

$$(K2 - K3 \cos(\text{Theta}))^b$$

MATERIAL CONSTANTS

m = 1.24 kg/m  
 a = 171.3  
 b = 1.52  
 Rho.θ = 2000 kg/cu.m

DERIVED CONSTANTS

K1 = 1.995645  
 K2 = 0.019016  
 K3 = 0.01879  
 COS Th.1=0.781116

MACHINE CONSTANTS

l = 0.05 m  
 w = 0.05 m  
 R = 0.233 m  
 h1 = 0.12 m  
 h0 = 0.018 m  
 v = 2.24 m/s  
 N = 91.80 rpm  
 Rho.c = 1378 kg/cu.m

INTEGRATION LIMITS

Th.1 = 0.674345  
 Th.0 = -0.1075

INTERVAL (10 off)

x = 0.078185  
 x/3 = 0.026062

COMPRESSION TIME

t = (s) 0.07

Theta	Multiplier	I	Multiple
-0.1075	1	380994.9	380994.9
-0.02932	4	659208.3	2636833
0.048867	2	601682.2	1203364
0.127051	4	316282.3	1265129
0.205236	2	146644	293288
0.283421	4	72244.46	288977.8
0.361606	2	38894.53	77789.05
0.439791	4	22621.66	90486.65
0.517976	2	13983.93	27967.87
0.59616	4	9059.098	36236.39
0.674345	1	6081.499	6081.499
		sum	6307149
		Integral Value	X x/3 164374.5
		Total Force (kN)	164

Figure A5.4 Computer Output

INTEGRATION BY SIMPSON'S RULE

CONICAL DISC COMPACTOR

I = K1

$$(K4 - K5 \cos(\theta))^b$$

MATERIAL CONSTANTS

m = 1.24 kg/m  
 a = 171.3  
 b = 1.52  
 Rho.0 = 2000 kg/cu.m

DERIVED CONSTANTS

K1 = 1.995645  
 K4 = 0.003489  
 K5 = 0.003263  
 COS Th.1 = -0.2605

MACHINE CONSTANTS

l = 0.05 m  
 Phi = 10 Degrees  
 Phi = 0.175 radians  
 w = 0.05 m  
 R = 0.233 m  
 h1 = 0.12 m  
 h0 = 0.018 m  
 v = 2.24 m/s  
 N = 91.80 rpm  
 Rho.c = 1378 kg/cu.m

INTEGRATION LIMITS

Th.1 = 1.83434  
 Th.0 = -0.1073

INTERVAL (10 off)

x = 0.194164  
 x/3 = 0.064721

COMPRESSION TIME

t = (s) 0.19

Theta	Multiplier	I	Multiple
-0.1073	1	616182.2	616182.2
0.086867	4	641774.5	2567098
0.281031	2	351521.8	703043.5
0.475195	4	162700.4	650801.7
0.669358	2	80923.96	161847.9
0.863522	4	44972.47	179889.9
1.057685	2	27600.4	55200.8
1.251849	4	18380.97	73523.87
1.446013	2	13089.62	26179.24
1.640176	4	9857.387	39429.55
1.83434	1	7785.656	7785.656
		sum	5080982
		Integral Value	X x/3 328847.3
		Total Force (kN)	329

Figure A5.5 Computer Output

RADIAL DISC COMPACTOR

DISC RADIUS	RESULTANT FORCE	COMPRESSION TIME
m	kN	s
0.2	155	0.07
0.25	169	0.07
0.3	181	0.08
0.35	192	0.09
0.4	202	0.09
0.45	212	0.1
0.5	220	0.1
0.55	228	0.11
0.6	236	0.11

CONICAL DISC COMPACTOR

DISC RADIUS	phi = 7.5 degrees			phi = 10 degrees			phi = 12.5 degrees		
	RESULTANT FORCE	COMPRESSION TIME		RESULTANT FORCE	COMPRESSION TIME		RESULTANT FORCE	COMPRESSION TIME	
m	kN	s		kN	s		kN	s	
0.2	N/A	N/A		311	0.18		284	0.16	
0.25	381	0.24		338	0.19		308	0.17	
0.3	409	0.25		362	0.21		330	0.18	
0.35	434	0.26		384	0.22		350	0.19	
0.4	458	0.28		405	0.23		369	0.2	
0.45	480	0.29		425	0.24		387	0.22	
0.5	501	0.3		443	0.26		404	0.23	
0.55	522	0.31		461	0.27		420	0.24	
0.6	541	0.33		478	0.28		435	0.25	

Figure A5.6 Computer Output

## REFERENCES

- 1 Klinner W. Engineering Developments to aid the Utilisation of Straw; Straw, Soils & Science, A.F.R.C. Silsoe, Sept 1985. 22-23
- 2 Hare P. Straw as a fuel in the U.K., P.I.R.A. International Conf. Straw, a Valuable Raw Material, Vol 3, Cambridge, Oct. 1987.
- 3 Shuler M.L. Utilisation and recycle of Agricultural Wastes and Residues, CRC Press 1980.
- 4 Min. of Ag., Stubble Burning to be banned, The Times, Dec. 1st, 1989.
- 5 Christian D, Goss M, Bacon E, Smallfield B. Investigating the problems of Straw Incorporation, - Straw Soils and Science A.F.R.C., Silsoe Sept 1985, 4-5,15.
- 6 Grahm J.P. et al., Effects of straw residues on the establishment of growth and yield of Autumn sown cereals, J.Agric Eng. Res. 1986, 33, 39-49
- 7 Straw: Use the match with care, Farmers Weekly, Feb 21 1986, 38
- 8 A.D.A.S., Tackling straw, M.A.F.F. booklet, 1983
- 9 A.D.A.S., Straw Use and Disposal, M.A.F.F., 1985, booklet No 2419
- 10 A-Z of Straw Disposal, Farmers Weekly, Aug 1 1986, 19.
- 11 Making more of straw, Power Farming, Oct 84.
- 12 McAuliffe C.A., Oil from Straw, P.I.R.A. International Conf., Straw - Opportunities and Innovations, Peterborough, Vol 3, (30), May 1990
- 13 Staniforth A R. Straw for fuel feed and Fertiliser, Farming Press, 1982.
- 14 Brenndorfer M. Joint enterprise and utilisation of a briquetting plant for straw, Kuratorium fur Technik und Bauwesen in der Landwirtschaft, 1985/6

- 15 Smith I E, Probert S D, Stokes R E, Hansford R J, Briquetting of wheat straw, J. Agric Eng Res, June 77, Vol 22, (2) 105-111.
- 16 Farm & Industrial Buildings Ltd., Northampton, Private Correspondence, July 1987.
- 17 Seven ways with straw, Power Farming, Dec 1986.
- 18 Straw: Forage for fuel, Farmers Weekly, Aug 7 1987, 22-23.
- 19 A.D.A.S., Straw as a fuel for heating greenhouses, M.A.F.F. 1985, booklet No. 2386.
- 20 Hawkins J C. "Straw as a fuel", Private consultative paper for Howard Rotavator Co Ltd. 1980.
- 21 Curley R G, Dobie J B, Parsons P S. Comparison of Stationary and Field Cubing of Forage. Trans A.S.A.E. 1973, 16 (2) 361-364, 366.
- 22 Lundell V J, Hull D O. Field Production of Hay wafers. Agric. Eng. St. Joseph Michigan 1961, 42 (8) 412-415, 423.
- 23 Poore B B, Herren K and Buchele W F. Field Wafering; an evaluation. 1968 Agric. Eng. Sept 1968, 526-7, 533.
- 24 Reece F N. Power Requirements for Forming Wafers in a Closed Die Process. Trans A.S.A.E. 1967, 10, 150-150.
- 25 Dobie J B. A Research Engineer looks at roughages. Proc. Feed Prod. Kansas City, Sept 1959, p32.
- 26 Cade W M. Recent experiments in wafering hay. Pap 59-616, winter meet A.S.A.E. Dec. 1959.
- 27 Chaplin R V. Straw Wafering N.I.A.E. Silsoe, N.I.A.E. Divisional note 1975 (unpublished), DN/FC/614/1390.
- 28 Klinner W E, Knight A C. Mechanical processing of staw for fuel. N.I.A.E. Divisional note 1980 (unpublished).
- 29 Bruhn H D. Pelleting grain and hay mixtures. Aric. Eng. St. Joseph Michigan 1955, 36 (5) 330.
- 30 Butler J L, McColly H F. Factors affecting the pelleting of hay. Agric. Eng. St. Joseph Michigan 1959, 40 (8) 442.

- 31 Bellinger P L, McColly H F. Energy requirements for forming hay pellets. Agric. Eng. St. Joseph Michigan 1961, 42 (5) 244.
- 32 Chancellor W J. Formation of hay wafers with impact loads. Agric. Eng. March 1962, 136-138, 149.
- 33 Shepperson G, Grundey J K. Experiments in the Production of Hay Wafers. Journal Agric. Eng. Res. 1962, 7 (2) 105 - 111.
- 34 Mewes E. The behaviour of compressed material in compression chambers. Landtechnische Forschung, 1958, 8 (6) 158-164 (N.I.A.E. Translation Aug 1982).
- 35 O'Dogherty M J and Wheeler J A. Compression of straw to high densities in Closed Cylindrical Dies. J Agric. Eng. Res. (1984) 29, 61-72.
- 36 Neale M A. Research and Development for on-farm straw packaging machines. P.I.R.A. International Conf. 1987, Straw a Valuable Raw Material Vol 1 (7) 115-135.
- 37 Neale M. A. A Review of current straw handling techniques. P.I.R.A. International Conf. 1990, Straw - Opportunities and Innovations, Vol 3 (26).
- 38 Klinner W E, Chaplin R V. Developments in straw densification. Agric. Progress, 1977, 52, 59-67.
- 39 Private correspondence with Western Machinery & Equipment Co. Ltd., Ivybridge, Devon, 9th March 1984.
- 40 Straw Briquetting: Inclined Discs, Howard Machinery plc., Patent No. UK8320134, 26th July, 1983.
- 41 Straw Extrusion, Howard Machinery plc., Patent No. UK8332827. 8th December, 1983.
- 42 Straw Compression, Howard Machinery plc., Patent No. UK8405786. 6th March, 1984.
- 43 Straw Briquetting Machine, British Sugar plc., Patent No. US278803. 1st December, 1988.

- 44 Percival J. The Wheat Plant.
- 45 Petersen P.B. Separation and characterisation of botanical components of straw, P.I.R.A International Conf., Straw a Valuable Raw Material?, Vol 1,(1), Cambridge, 1987.
- 46 Theander O. and Aman P. Straw and other fibrous By-Products as Feed, Elsevier Science Publ. B.V. Amsterdam, 1984.
- 47 Lowson J. Textbook on Botany, 15th Ed., University Tutorial Press
- 48 Hector J.M. Intro. to the Botany of Field Crops, Vol.1, Cereals.
- 49 Rehkugler G.E. and Buchele W.F. Biomechanics of forage wafering, Transactions Am. Soc. Agric. Eng'rs., 1969, 12, 1, pp1-8,12
- 50 Teisen P., Lett G, On-Farm Straw-Fired Heating Systems, P.I.R.A 2nd International Conf., Straw - Opportunities and Innovations, Vol. 3,(32), Peterborough, 1990. (Noted Verbal Statement).
- 51 Roberts E.B., High Speed Bonding of Fibrous Agricultural Waste, Unpublished Undergraduate Project, Dept., of Mech. Eng. L.U.T., Academic Year 1983/84.
- 52 Colley S.R., High Speed Compaction of Agricultural Waste, Unpublished Undergraduate Project, Dept., of Mech. Eng. L.U.T., Academic Year 1984/85.
- 53 Gilbert J., An Investigation into Energy Losses during High Speed Compaction of Fibrous Agricultural Waste, Unpublished Undergraduate Project, Dept., of Mech. Eng. L.U.T., Academic Year 1985/86.
- 54 Pledge L., The Compaction of Fibrous Agricultural Waste, Unpublished Undergraduate Project, Dept. of Mech Eng. L.U.T., Academic Year 1987/88.
- 55 Purdy S.J., The Compaction of Fibrous Agricultural Waste, Unpublished Undergraduate Project, Dept. of Mech Eng. L.U.T., Academic Year 1988/89.
- 56 Burrage C.J. The Behaviour of Fibrous Agricultural Waste in

- Compression Chambers, Unpublished Undergraduate Project, Dept. of Mech Eng. L.U.T., Academic Year 1989/90.
- 57 Metcalf J.R., The Mechanics of the Screw Feeder, I.Mech.E Proceedings, Manipulative & Mechanical Handling Grp., 1965-6, 180,(1).
- 58 Attfield S., Kaye M., Ulliyart G., A Straw Precompactor, Final year undergraduate Design Project, Dept. of Mech. Eng., L.U.T., academic year 1985/86.



## BIBLIOGRAPHY

Texts and Journals other than those specifically referenced.

Black's Agricultural Dictionary, Clayton.

Ferrero G L, Grassi G, Williams H E, (Ed.) Biomass Energy: From Harvesting to Storage, Elsevier Applied Science.

Hobson P, Hashimoto A G, (Ed.) Biological Wastes, Elsevier Applied Science.

Kent N L, Technology of Cereals, Pergamon Press.

Leighton Wellman B, Introduction to Graphical Analysis and Design, McGraw-Hill.

Polukhin P, Fedosov N, Korolyov A and Matveyev Y, Rolling Mill Practice, Peace Publishers, Moscow.

Ryder G H, Strength of Materials, MacMillan.

Wake W C. Adhesion and the Formulation of Adhesives, Applied Science Publishers.

