

Comparison of scientific CMOS camera and webcam for monitoring cardiac pulse after exercise

Yu Sun^{1,2}, Charlotte Papin³, Vicente Azorin-Peris¹, Roy Kalawsky¹, Stephen Greenwald⁴, and Sijung Hu^{1*}

¹ Department of Electronic and Electrical Engineering, Loughborough University, Ashby Road, Loughborough, Leicestershire, LE11 3TU, UK

² Department of Biomedical Engineering, Shanghai Jiao Tong University, Shanghai, 200240, P. R. China

³ Department of Electronics & Embedded Systems, Polytech Paris-Sud, Université Paris Sud, Maison de l'ingénieur - bâtiment 620 - 91405 Orsay Cedex, France

⁴ Pathology Group, Institute of Cell & Molecular Science, Barts & The London School of Medicine and Dentistry, London, E1 2ES, UK

ABSTRACT

In light of its capacity for remote physiological assessment over a wide range of anatomical locations, imaging photoplethysmography has become an attractive research area in biomedical and clinical community. Amongst recent iPPG studies, two separate research directions have been revealed, i.e., scientific camera based imaging PPG (iPPG) and webcam based imaging PPG (wPPG). Little is known about the difference between these two techniques. To address this issue, a dual-channel imaging PPG system (iPPG and wPPG) using ambient light as the illumination source has been introduced in this study. The performance of the two imaging PPG techniques was evaluated through the measurement of cardiac pulse acquired from the face of 10 male subjects before and after 10 min of cycling exercise. A time-frequency representation method was used to visualize the time-dependent behaviour of the heart rate. In comparison to the gold standard contact PPG, both imaging PPG techniques exhibit comparable functional characteristics in the context of cardiac pulse assessment. Moreover, the synchronized ambient light intensity recordings in the present study can provide additional information for appraising the performance of the imaging PPG systems. This feasibility study thereby leads to a new route for non-contact monitoring of vital signs, with clear applications in triage and homecare.

Keywords: Photoplethysmography (PPG), remote, exercise, webcam, ambient light

1. INTRODUCTION

Photoplethysmography (PPG), as first described in the 1930s¹, is a simple, low-cost, and non-invasive optical bio-monitoring technique used to measure the blood volume changes that occur in the human body due to the pulsatile nature of the circulatory system². Since its modern conception decades ago, its ability to monitor vital physiological parameters in real-time, e.g., blood oxygen saturation, heart and respiration rates, cardiac output and blood pressure, has gained significant attention in the biomedical and clinical community and made PPG a standard of monitoring in various applications. However, the contact sensing modus constrains its practicability in situations of skin healing evaluation, or when free movement is required. One potential way to overcome these problems is to use the recently introduced technique of imaging PPG, which is a remote, contactless diagnostic technique that can assess peripheral blood perfusion³⁻⁸.

With significant achievements and improvements of imaging techniques, the past decade has witnessed a prompt growth and substantial accumulation of literature regarding imaging PPG. For instance, Wieringa and colleagues have introduced a multiple wavelength imaging PPG device that provides a possible route toward contactless blood oxygen saturation assessment⁴, and Poh and colleagues have reported a webcam based remote PPG signal acquisition technique using ambient light illumination⁶. These two specific examples indicate two research directions within imaging PPG: scientific camera based imaging PPG (iPPG) and webcam based imaging PPG (wPPG). The former imaging PPG setup, which usually comprises high sensitivity and sample rate and is mostly used with an artificial illumination source, has been proven to be superior in the assessment of multiple physiological parameters, and the latter imaging PPG setup, which normally uses ambient light as the illumination source, shows its advantage in terms of simplicity and low cost. Though successful in acquiring physiological parameters, e.g., heart rate, a number of key questions still remain for the

* S.Hu@lboro.ac.uk; phone: +44 1509 227058

wPPG technique, particularly how the ambient light intensity might influence the performance of the system. Compared to the accumulated literature pertaining to imaging PPG, there are few studies that compare these two techniques and appraise their performance within the same experiment. In our previous studies^{7,8}, an imaging PPG system has been introduced, and its practicability and reliability in terms of remote assessment of the cardiovascular system has been shown. Therefore, in the present study, a validation system, including an scientific colour camera, a webcam, ambient light intensity measurements, and a contact PPG (cPPG) sensor, has been created to comparatively assess the reliability and sensitivity of ambient light-based imaging PPG measurements in accessing the cardiovascular system during and after exercise. The nature of pulsatile variations in the PPG signals under different exercise levels was also studied to appraise the influence of different exercise levels on the cardiovascular system.

2. MATERIALS & METHODS

2.1 Subjects

A total of ten healthy subjects (all male; age=29.2±8.1 yrs; height=1.80±0.07 m; BMI=25.0±3.7 kg/m²) recruited from Loughborough University were enrolled in this study. None of them had any known cardiovascular disease and none were diabetic. The investigation conformed to the principles outlined in the Declaration of Helsinki (1989) of the World Medical Association, and was approved by the local Ethical Committee. The nature of the research was explained to the subjects prior the recordings, and informed consent was obtained. The subjects were asked to refrain from consuming caffeine or alcohol, and asked not to smoke or undertake strenuous exercise for the two hours leading to the study.

2.2 Instrument setup

A schematic diagram of the present validation platform is depicted in Fig. 1. The scientific colour CMOS camera (Model: MC1311, Mikrotron GmbH, Unterschleissheim, Germany) with maximum resolution of 1280×1024 pixels was focused on the face of the participants. The distance between camera and face was approximately 35 cm. A colour video was also recorded from the face via a webcam (Model: Webcam Pro 9000, Logitech, Fremont, USA) which was fixed about 20 cm from the face. In all experiments, a commercial pulse oximetry contact sensor (Model: P871RA, Viamed, UK) was placed on the index finger of the left hand to measure the participant's pulse signal for validation. The analogue signal outputs from the contact sensor were digitised using a DISCO4 (Dialog Devices, UK) data acquisition system incorporating a 12-bit A/D converter running at a sample rate of 128 Hz. To appraise the ambient light intensity, an optical spectrometer (Model: USB4000, Ocean Optics, Dunedin, USA) was also employed in the present study. The images captured from the CMOS camera were synchronized to the physiological signals acquired from the contact sensor, the spectrometer and webcam via an additional signal from the camera. Specifically, when initiating the iPPG capture, a trigger signal was sent to initialize the recording of the spectrometer and cPPG sub-system, and a red LED ($\lambda=650$ nm) placed within the field of view of the webcam was simultaneously turned on for synchronization of the wPPG sub-system.

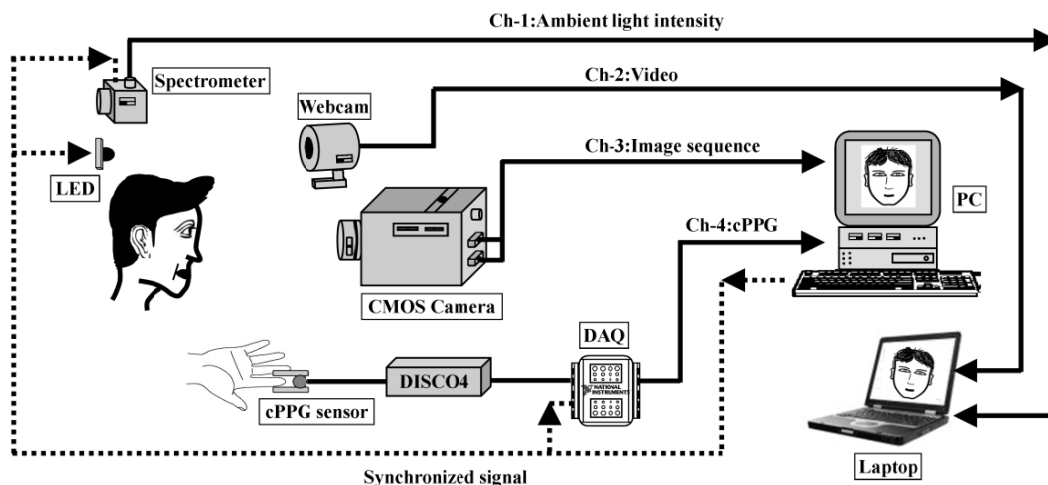

Figure 1. Experimental setup of remote OPI system.

2.3 Experimental protocol

The details of the experimental protocol were based on our previous studies^{7,8}. Briefly, the participants were required to sit on an adjustable chair and rest for at least 10 min, at which time a blood pressure measurement was taken from the right arm via a digital blood pressure monitor (Model: M6, Omron, Japan). The contact PPG signal acquisition and ambient light intensity monitoring were then initialized to wait for the trigger signal from the CMOS camera. Afterwards, video capture from the webcam was configured via custom-built software in MATLAB (MathWorks, Nantick, Massachusetts, USA), i.e., the size of the image was recorded at 320×240 pixels and a fixed frame rate of 30 fps. For each subject, around four minutes of video was captured via the webcam. Approximately 5 sec later, the CMOS camera was started, at which time three synchronization signals were activated for simultaneous recording of finger probe, webcam, and spectrometer measurements. A video of 30 sec duration was recorded with an image size of 640×512 pixels and a frame rate of 50 fps. To appraise the performance of the platform and investigate the influence of different exercise levels on the cardiovascular system, additional measurements were taken after each exercise phase, i.e., 15 km/h (exercise 1) and 25 km/h (exercise 2) cycling for 10 minutes on a gym machine (Model: XR-580, PowerTrek, UK). A final physiological measurement was taken after a further 10 min rest period. All measurements were made by a trained operator in a temperature-controlled (24.5 ± 1.7 °C) lab room.

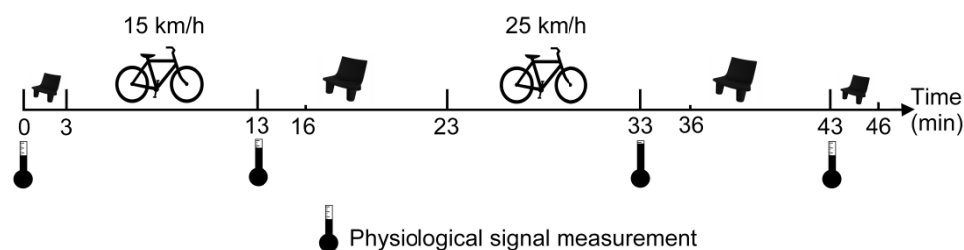

Figure 2. Schematic of the experimental protocol.

2.4 Image processing

In previous studies, a 2-D cross-correlation based motion compensation technique has been proposed and validated for extraction of physiological parameters during various exercise levels⁸. In the present study, dual-channel images were recorded in post-exercise conditions, which contain relatively small motion artefacts. Hence, a simple yet efficient averaging approach was adopted to attenuate the motion artefacts in the present study⁵. Specifically, after a set of recordings were acquired, a Bayer function has been adopted to extract the three channel (red, green, and blue) images for the CMOS camera. The raw image frames from iPPG and wPPG were divided into discrete sub-windows and a new set of reduced frames were calculated, where the value of each pixel in the reduced frame was set as the average of all the pixel values within each sub-window (8×8 pixels for both videos in the present study), yielding PPG signals at each pixel position across a sequence of frames. The PPG signals were then band-pass filtered using a 5th order Butterworth filter. Cut-off frequencies were set at [0.5, 4] Hz to allow a wide range of heart rate measurements. Three PPG signals were then obtained, i.e., iPPG, wPPG, cPPG.

2.5 Signal analysis

Fourier Transform (FT) has been widely utilized in conventional PPG signal processing by merit of its simplicity and ability to easily provide fundamental physiological related information. However successful, uncritical use of FT could still lead to ambiguous results since it assumes that signals are steady-state when, in reality, physiological signals are generally transient in nature. Moreover, several recent imaging PPG studies have revealed that a combination of both time and frequency domain information could provide more reliable physiological assessments^{3,5,7,8}. For instance, time-dependent heart/respiration rate traces have been uncovered from a 290 sec post-exercise video of a volunteer who was asked to perform 50 knee bends⁵. Therefore, a joint time-frequency analysis, or time-frequency representation (TFR), has been employed in the present study to obtain the temporal localization of the signal's spectral components (for a review, see^{9,10}). Based on our experience in iPPG signal processing^{7,8}, a smoothed pseudo-Wigner-Ville distribution (SPWVD) was chosen for TFR estimation of the obtained PPG signals:

$$SPWVD(t, f) = \int h(\tau) \int g(s - t) x\left(s + \frac{\tau}{2}\right) x^*(s - \frac{\tau}{2}) e^{-j2\pi f\tau} ds d\tau \quad (1)$$

where $x(s)$ and $x^*(s)$ are the signal and its complex conjugate respectively, $g(s)$ and $h(\tau)$ are two smoothing windows whose effective lengths independently determine the time and frequency smoothing spread. In the present study, Kaiser-Bessel function is adopted as both the time and frequency smoothing window.

2.6 Statistical analysis

Significant difference between the physiological measurements under differing conditions was tested with analysis of variance (ANOVA, FACTOR = condition) to demonstrate the influence of exercise on the cardiovascular system. The group difference was evaluated via Posthoc analysis using Duncan's test. Moreover, to test the performance of the two imaging PPG systems, ANOVA (FACTOR = measurement techniques) was performed for comparison between wPPG, iPPG, and cPPG. All analyses were performed with α (Type I error) set at 0.05 using the statistical software program SPSS for Windows, version 17.0.

3. RESULTS

3.1 Physiological measurements

In the present study, a total of four physiological measurements were taken from each of the participants (Fig. 2). Fig.3 summarizes the results of the measured variables: HR, systolic blood pressure (SBP), and diastolic blood pressure (DBP).

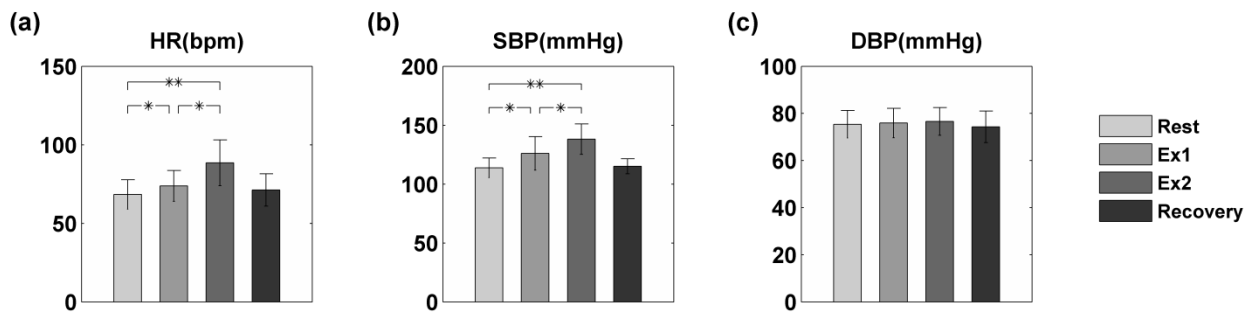

Figure.3 Effects of exercise on blood pressure and heart rate. Each bar represents the average SBP (a), DBP (b), and HR (c) for each state (rest, ex1, ex2, and recovery). Error bars show standard deviations. The statistical results are highlighted with * for $p < 0.05$ and ** for $p < 0.01$.

To statistically analyse the influence of exercise on the cardiovascular system, separate ANOVAs with Post hoc tests were conducted on the obtained variables. The statistical results are shown in Fig.3. Significant effects of exercise have been identified in HR and SBP ($F=6.36, p < 0.001$ & $F=10.77, p < 0.000$). Post hoc tests revealed that the HR and SBP after both exercises were significantly higher than those in the rest condition (ex1 vs. rest, $p < 0.05$, ex2 vs. rest, $p < 0.01$). In addition, a significant difference between different exercise levels was also detected in HR and SBP, while the hemodynamic parameters all returned to the rest level after 10 minutes rest.

3.2 Heart rate detection

Fig. 4 demonstrates an example of the PPG signals obtained from (a) CMOS camera and (d) web-cam of a single subject (#1) in the rest condition. Additionally, three images were presented to illustrate the decomposed Red, Green, and Blue channels for both cameras ((b) & (e)). Separate PPG signals obtained from each of these three channels were also exhibited, e.g., plethysmographic waveforms are visible in Fig. 4(c) for CMOS camera and (f) for web-cam. Oscillations for HR are most pronounced in the Green channel for the web-cam while the scientific CMOS camera shows comparable PPG signals for all three channels.

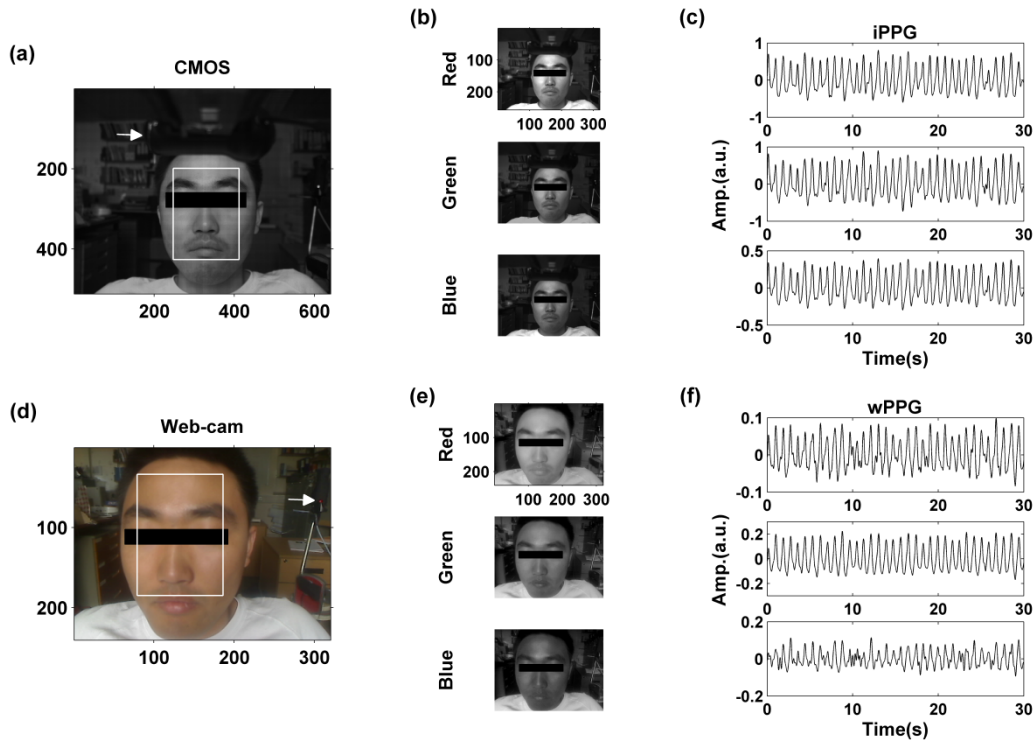

Figure 4. Representative figure showing an original frame from (a) the CMOS camera (frame 49, $t=1$ s), (b) the decomposed RGB channels, and (c) the corresponding PPG (iPPG) signals. A similar approach has been adopted for exhibiting the results of the web-cam (frame=29, $t=1$ s). The signal is from Sub#1 (Male, age=27 yrs) at rest condition. The position for obtaining the PPG signal (iPPG & wPPG) is highlighted with a white box. The white arrow demonstrates the position of the web-cam in (a) and the synchronization red LED in (d).

To estimate the cardiac pulse, the TFR analysis has been employed to reveal the obtained plethysmographic waveform for different techniques. The TFR traces derived from the contact PPG sensor, CMOS camera (Green channel) and webcam (Green channel) have been shown in Fig. 5. It can be seen that the HR frequency (~ 1.1 Hz) and 2nd harmonic components show close agreement for three measurements.

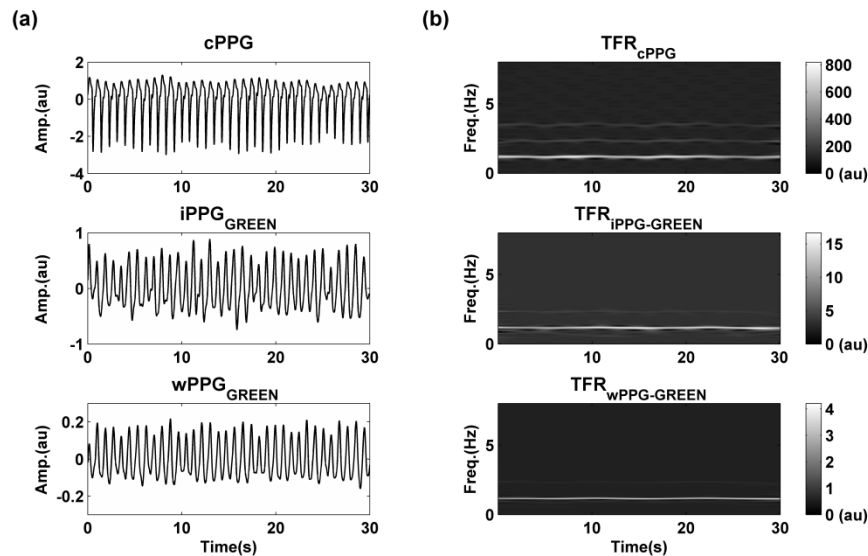

Figure 5. A representative figure showing (a) contact, CMOS camera, and webcam PPG signals, and (b) the corresponding TFR results. The signals iPPG_{GREEN} and wPPG_{GREEN} were highly correlated, as shown in Fig.4(c) & (f).

3.3 The influence of ambient light intensity

Fig.6 depicts an example of the 3 min recordings from the wPPG signals together with the light intensity for (a) Green and (b) Red channels. Intensity dependent raw PPG signals have been revealed for both channels. Interestingly, though the light intensity of the Red channel is significantly higher than the Green channel, a pronounced plethysmographic waveform is identified in the Green channel.

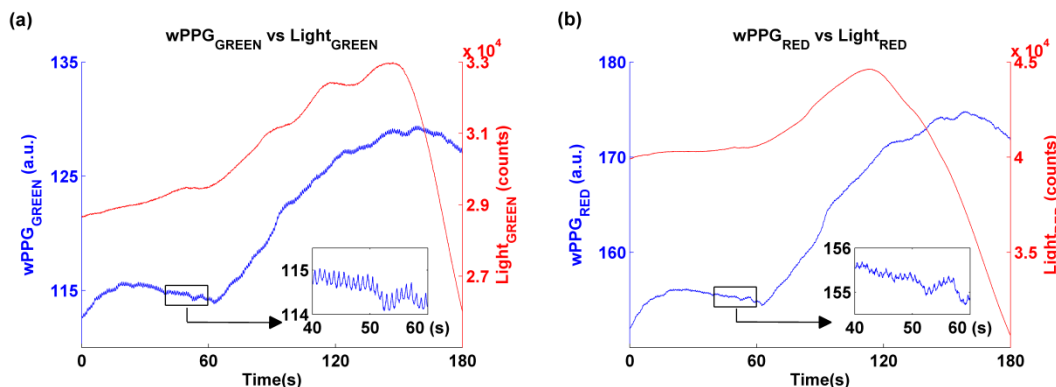

Figure 6. A representative figure showing the influence of light intensity on the obtained wPPG signals for (a) Green channel and (b) Red channel. A magnified window (40-60s) is also demonstrated for both channels, from which a pronounced and clear plethysmographic waveform is revealed in the Green channel. The signals are from Sub#1 (Male, age=27 yrs) at rest condition.

3.4 Imaging PPG vs. contact PPG

To statistically evaluate the performance of the two imaging techniques, an ANOVA analysis (FACTOR = measurement technique) was employed to compare the difference between these two measurements and the gold-standard contact measurements. The HR_{wPPG} and HR_{iPPG} were obtained through averaging the HR within the TFR_{GREEN} traces, which were calculated from the synchronized 30 sec recordings. In the present study, only the comparison of the rest conditions is considered. Specifically, three physiological monitoring techniques revealed non-significant difference in cardiac pulse detection under rest condition ($F=0.01$, $p=0.9879$).

4. DISCUSSION

A dual-channel imaging PPG system using ambient light illumination has been introduced and evaluated in the present study. The performance of both imaging PPG techniques was appraised by comparing them to a commercial pulse oximetry sensor. Statistical analysis shows no significant difference between these three methods for PPG signal capture, suggesting both imaging PPG systems can successfully obtain information about the cardiovascular variables.

The optimal amount of exercise to maintain fitness and reduce mortality from cardiovascular disease remains a matter of debate^{11,12}. Hence, it is a worthwhile endeavour to develop a convenient, remote, and reliable technique to monitor the cardiovascular situation before, during and after exercise. From the physiological measurements obtained via the digital blood pressure meter, heart rate and systolic blood pressure patterns have been shown to be dependent on the intensity of exercise, which agrees well with previous studies^{7,8,13,14}. Interestingly, compared to the medium exercise duration (5-min)^{7,8}, a longer exercise duration (10-min) in the present study does not trigger a higher response.

It can be seen in Fig. 4 that a pronounced Green channel plethysmographic signal is uncovered, where a similar pattern has been revealed for all subjects. In fact, for most conditions, the light intensity of Red channel is significantly higher than Green channel (Fig.6). This finding is consistent with several webcam and consumer level digital camera imaging PPG studies^{5,6}. Actually, it has been indicated in the literature that (oxy-) haemoglobin absorbs more green light than red light and penetrates sufficiently deep into the skin as compared to blue light⁵. Such a pattern is absent from the iPPG signals, which might be related to the relatively similar quantum efficiency for Red, Green, and Blue channels in the camera.

Although the subjects were requested to main motionless during recordings, movements of the subject relative to the camera may occur since the sensor has no contact with the skin. Hence, it is important to recognize the limitations of this study. During the recordings, typical involuntary small movements included mild leaning of the body (and hence the head) towards/away from the camera due to deep breathing, especially after the various exercise conditions. Another

limitation is the quantification of the influence of ambient light intensity on the obtained imaging PPG signals. Although the raw PPG signals from the webcam present an intensity dependent pattern, the relationship between the intensity and the PPG signals, e.g., the amplitude of the ac components, is still unclear. A further complete study with full set of subjects and conditions is needed to assess the performance of both imaging PPG techniques in detecting the cardiac pulse after various exercise intensities as well as to quantify the influence of light intensity on the imaging PPG signals.

5. CONCLUSION

In this study, we have introduced and implemented a dual-channel imaging PPG system, which couples a sensitive scientific CMOS camera and a webcam, and uses ambient light illumination. The performance of both imaging PPG techniques exhibit comparable functional characteristics in detecting the cardiac pulse, indicating a promising alternative to conventional contact PPG. Hence, the results of the present study provide further evidence for webcam-based imaging PPG. Given the low cost and convenience, the webcam leads to a new insight into improving access to medical care and homecare. In comparison, imaging PPG techniques using high speed and high sensitivity cameras maintain a superior capability for assessment of multiple physiological parameters.

ACKNOWLEDGEMENT

This work was supported by the National Institute for Health Research under Grant No. FPD1 II-FS-0109-11005. The authors would like to thank Loughborough University and Shanghai Jiao Tong University for their support.

REFERENCES

- [1] Hertzman, A.B., "Photoelectric plethysmography of the fingers and toes in man," *Exp. Biol. Med.*, **37**(3), 529-534 (1937).
- [2] Allen, J., "Photoplethysmography and its applications in clinical physiological measurement," *Physiol. Meas.*, **28**(3), R1-39 (2007).
- [3] Hulsbusch, M., and Blazek, V., "Contactless mapping of rthymical phenomena in tissue perfusion using PPGI," *Proc. SPIE*, **4683**, 110-117 (2002).
- [4] Wieringa, F.P., Mastik, F., van der Steen, A.F.W., "Contactless multiple wavelength photoplethysmographic imaging: a first step toward 'SpO(2) camera' technology," *Ann. Biomed. Eng.*, **33**(8), 1034-1041 (2005).
- [5] Verkruyse, W., Svaasand, L.O., and Nelson, J.S., "Remote plethysmographic imaging using ambient light," *Opt. Express*, **16**(26), 21434-21445 (2008).
- [6] Poh, M.Z., McDuff, D.J., and Picard, R.W., "Non-contact, automated cardiac pulse measurements using video imaging and blind source separation," *Opt. Express*, **18**(10), 10762-10774 (2010).
- [7] Sun, Y., Hu, S., Azorin-Peris, V., Zheng, J., Greenwald, S., Chambers, J., and Zhu, Y.S., "Detection of physiological changes after exercise via a remote opto-physiological imaging system," *Proc. SPIE*, **7891**, 78910E-1-8 (2010).
- [8] Sun, Y., Hu, S., Azorin-Peris, V., Greenwald, S., Chambers, J., and Zhu, Y.S., "Motion-compensated noncontact imaging photoplethysmography to monitor cardiorespiratory status during exercise," *J. Biomed. Opt.*, **16**, 077010 (2011).
- [9] Qian, S., and Chen, D., "Joint time-frequency analysis," *IEEE Signal Proc. Mag.*, **16**(2), 52-67 (1999).
- [10] Hlawatsch, F., and Boudreaux-Bartels, G.F., "Linear and quadratic time-frequency signal representations," *IEEE Signal Proc. Mag.*, **9**(2), 21-67 (1992).
- [11] Williams, P.T., "Relationships of heart disease risk factors to exercise quantity and intensity," *Arch. Intern. Med.*, **158**(3), 273-245 (1998).
- [12] Lee, I.M., Hsieh, C.C., and Paffenbarger, R.S., "Exercise intensity and longevity in men-the Harvard Alumni Health Study," *J. Am. Med. Assoc.*, **273**(15), 1179-1184 (1995).
- [13] Lauer, M.S., Okin, P.M., Larson, M.G., Evans, J.C., and Levy, D., "Impaired heart rate response to graded exercise. "Prognostic implications of chronotropic incompetence in the Framingham Heart study," *Circulation*, **93**(8), 1520-1526 (1996).
- [14] Wang, L., Pickwell-MacPherson, Liang, Y.P., and Zhang Y.T., "Non-invasive cardiac output estimation using a novel photoplethysmogram index," *Proc. of 31st IEEE EMBS*, pp. 1746-1749 (2009).