

Proceedings of the Operational Research Society Simulation Workshop 2016 (SW16)
A. Anagnostou, K. Hoad, M. Kunc eds.

A SIMULATION OF A POLICE PATROL SERVICE SYSTEM WITH MULTI-GRADE TIME-VARYING INCIDENT ARRIVALS

Miss. Hanjing Zhang

Loughborough University
Leicestershire, UK
H.Zhang@lboro.ac.uk

Dr. Lisa Jackson

Loughborough University
Leicestershire, UK
L.M.Jackson@lboro.ac.uk

Dr. Antuela Tako

Loughborough University
Leicestershire, UK
A.Takou@lboro.ac.uk

Prof. Jiyin Liu

Loughborough University
Leicestershire, UK
J.Y.Liu@lboro.ac.uk

ABSTRACT

Due to the squeeze on public expenditure, the funding cuts imposed on the police provide a great impetus to find an efficient incident response sequence with limited resources. This is especially the case for police response systems which exhibit the characteristics of time-varying volume of demand. In this paper, we investigate two types of priority queues in the patrol service system. Both the incident arrival rate and the scheduled staff level change with time. For such a system, there is no analytical model available to give close-form performance, so simulation is used for the study. Although dynamic priority queues which enable more flexibility in setting the sequence of service requests are widely applied in many service systems, such as the NHS service system, the simulation model results show that in police patrol service systems static priority queue performs better.

Keywords: Police patrol service system, Priority queue, Time dependent arrival rate

1 INTRODUCTION

Performance measures of police patrol service systems typically focus on response times, especially for incidents which need to be responded to immediately. Unlike manufacturing or transportation systems with well scheduled demand, police emergency service providers always face time-dependent service requests. Patrol officers must be ready to respond to an assigned incident of which the time and place cannot be known in advance. Management of staff allocation is usually based on a reasonable demand prediction using historical records so moderate understaffed periods may occur in practice.

In police patrol service systems, call handlers in front desks divide reported incidents into four grades based on their urgency. Only two grades of incidents, emergency incidents with threat to life and priority incidents with necessary officer attendance, require immediate response. The common target in the UK is to attend over 85% of emergency incidents within 15 minutes and reaching over 80% of priority incidents in 60 minutes (Leicestershire Police, 2013). With a lack of staff, police patrol service systems may fail to meet service targets, so there is a trade-off between satisfying emergency response targets and satisfying priority response targets. Similar to call centre systems, police patrol service systems can be modelled as a

queueing system. A good performance in responding to emergency incidents, with an acceptable priority incident response speed, is preferable for selecting a queue rule since emergency incidents have more serious consequences if they fail to be responded to in time. It cannot be assumed that such targets can be met when incidents are served on a first come first serve basis. Two types of queues can be used to model the police response system. Static priority queue, which serves priority incidents only when there is no emergency incidents presented, may reduce the speed in responding to priority incidents. Dynamic priority queues, including accumulating priority queues and threshold priority queues, that provide extra flexibility in service sequence have been already investigated in some service systems, such as the NHS. The work presented in this paper investigates the service quality in police patrol service systems with alternate moderate under-staffed and over-staffed periods via simulation. Extending previous work on priority queue systems with multi-grade arrivals, both arrival rate and staff level vary over time in this simulation model. According to the simulation results, static priority queues perform better than dynamic priority queues in police patrol service systems when service targets are hard to be achieved due to lack of staff.

The remainder of the paper is arranged as follows. The next section reviews the existing work on priority queues. Section 3 compares two different dynamic priority queues using simulation. First come first serve queues and static priority queues are discussed as special cases of dynamic priority queues. The last section gives conclusions and discusses the future research direction.

2 EXISTING MODELS OF PRIORITY QUEUES

Traditional static priority queues are analysed under the assumption that requests for service have fixed non-pre-emptive priorities. In such situations, no service resource will be allocated to requests for service from lower urgency grades while there are some high urgent grade requests present. This priority queueing sequence does make sense in some situations such as computer systems and telecommunication systems (Choi and Chang, 1999). However, in some situations like medical emergency service systems and police patrol service systems, requests for service from different urgency grades have different service targets and absolute priority for service does not exist (Henderson and Mason, 2004; Metropolitan Police, 2013). High urgency grade requests for service expect to receive a faster service than low urgency grade requests. Several dynamic priority queues have been proposed to provide more flexibility in response sequences. Among all the priority queues, accumulating priority queues and threshold priority queues attract the most interest.

Accumulating priority queue was used for a steady state queue by Kleinrock (1964). Upon arrival, queueing index of service start accumulating linearly over time. The higher the urgency grade, the greater the accumulation rate of queueing index function. Requests for service from low urgency grades, which experiences a long waiting time, will eventually be able to receive services even if some more urgent requests exist. Then Kleinrock and Finkelstein (1967) extended this method in which queueing index increases in proportion to some arbitrary power of waiting time. Another variant has been applied by Hay et al. (2006) in which initial queueing index also depends on urgency grades of requests for service. Recently Stanford et al. (2014) and Sharif et al. (2014) have derived waiting time distributions for linear accumulated priority queues for single server systems and multi-server systems in steady state.

Threshold priority queues have been investigated by setting thresholds to upgrade requests for service from low urgency grades so that they can be served when high urgency grade requests are still waiting in queues. In the model of Ridley et al. (2003), low urgency grade requests have dynamic priorities where they become high urgency if their waiting time exceeds a given value. Knessl et al. (2003) proposed a dynamic priority queue system in which once there are more than a certain number of requests from low urgency grades waiting for service, the head of low urgency grade request queues will be either upgraded or abandoned. Gurvich and Whitt (2010) proposed a queue length ratio threshold where the next service will be allocated to service requests from the head of the queue with certain service urgency whose queue length exceeds a specified proportion of the total queue length. Later Perry and Whitt (2013) introduced a

six-dimensional fluid model to approximate queue performances of fixed staff levels with time varying arrivals.

Compared to traditional static priority queues, dynamic priority queues may perform better in aligning service accessibilities with service target of different urgent grades of requests for service when there are insufficient staff available (Sharif et al., 2014). In practice, police patrol service systems will experience some moderate under-staffed periods due to staff unavailability. This paper is primarily concerned with system performances of different priority queues in the case of slight overload. The police forces prefer to select a priority queueing system which has a high tolerance for short periods of under-staffing.

3 SIMULATION MODEL FOR MULTI-GRADE SYSTEM

A discrete event simulation model is developed to replicate police patrol service systems for a period of 24 hours by a non-preemptive queue with time dependent Poisson arrivals. Time-varying requests for service arrival rate of all incidents, $\lambda(t)$, is estimated hourly by historical records from the local police force. Figure 1 plots the estimated time-varying arrival rate.

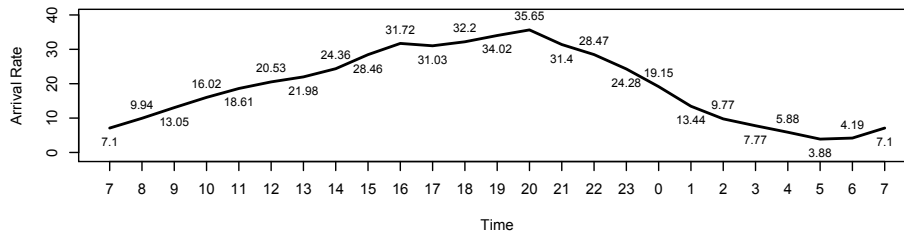

Figure 1 Time-Varying Arrival Rate per Hour

There are two urgent grades which have different service targets as defined in real police systems. In this simulation model, service durations are the time spend on dealing with incidents, which are restricted to a common exponential distribution. The elapsed times for patrol officers to travel to the scene of incidents are also modelled by an exponential distribution. According to real patrol activity records, the simulation parameters are listed in Table 1.

Table 1 Parameters of Queueing System Simulation

| Urgency Grade | Arrival Rate | Service Time | Travel Time |
|---------------|-------------------------|--------------|-------------|
| 1. Emergency | 30% $\lambda(t)$ / hour | 60 minutes | 5 minutes |
| 2. Priority | 70% $\lambda(t)$ / hour | on average | on average |

A working day for patrol activities start from 7am and finish at 7am. Although police patrol service systems run continuously from one day to the next, the demand for service around 7am in the morning is very low and the system around that time is almost empty. Therefore each day can be viewed as separated and each replication can simulate a 24-hour working day. The service quality is estimated hourly via simulation. The delay in response of the current hour is postponed to the next hour. Assume there are five predefined shifts for staff to take. Some overlaps of shifts exist to cover the rush hours of time-varying arrivals of requests for service. Thus, a working day is divided into several separated periods of different staff levels. With the help of integer programming, the staff level for each shift and each period in the simulation model is set as summarized in Table 2.

Table 2 Input Staff Levels for Each Replication

| Period Shift | 1 from 07:00 to 11:00 | 2 from 11:00 to 15:00 | 3 from 15:00 to 19:00 | 4 from 19:00 to 23:00 | 5 from 23:00 to 03:00 | 6 from 03:00 to 07:00 |
|-----------------|-----------------------------|-----------------------------|-----------------------------|-----------------------------|-----------------------------|-----------------------------|
| A (07:00-15:00) | 12 | 12 | | | | |
| B (11:00-19:00) | | 8 | 8 | | | |
| C (15:00-23:00) | | | 20 | 20 | | |
| D (19:00-03:00) | | | | 12 | 12 | |
| E (23:00-07:00) | | | | | 8 | 8 |
| Staff Level | 12 | 20 | 28 | 32 | 20 | 8 |

At time t , patrol officers have been dealing with existing incidents for a period of μ , where incidents arrive in the system earlier than $t-\mu$. Thus the average number of busy patrol officers $W(t)$, as defined in Jennings et al. (1996), is:

$$W(t) = \int_0^\infty \{ \lambda(t-\mu) \cdot \text{Probability}(\text{service_time} > \mu) \} d\mu \quad (1)$$

Since the average number of busy staff does not take the service targets into consideration, it may slightly under estimate the required staff level but still is a reasonable guideline. Figure 2 compares the input staff level in this simulation model (Table 2) in the straight lines, with the average number of busy patrol officers calculated via Equation (1) in the curve line. It is obvious that the simulation system will experience moderate under-staffing around 10:00, 14:00, 18:00, 20:00 and midnight. The following simulation analysis will mainly focus on the system performance of these understaffed periods.

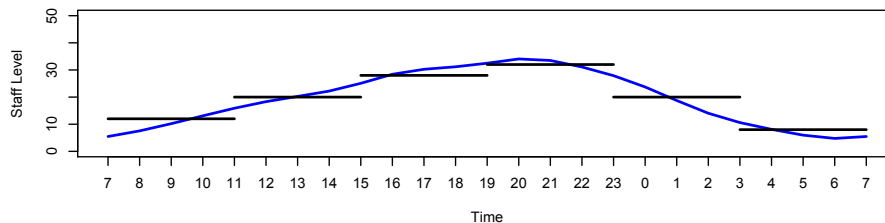

Figure 2 Simulated and Recommended Staff Levels

The queueing algorithms to be considered are essentially the accumulating priority queues discussed in Stanford et al. (2014) and the threshold priority queues discussed in Gurvich and Whitt (2010). First come first serve queues and static priority queues are also discussed as special cases in both the queue systems. The successful response probabilities are estimated by performing multiple (1,000) independent replications of simulation.

3.1 Accumulating Priority Queues

According to the work of Stanford et al. (2014), an emergency incident which arrives at time t_0 has a queueing index of $Q_1(t_0, t)$. Similarly, the queueing index for priority incidents are defined as $Q_2(t_0, t)$, where:

$$Q_i(t_0, t) = b_i \cdot (t-t_0), \quad i \in \{1(\text{emergency incidents}), 2(\text{priority incidents})\} \quad (2)$$

At the time when a patrol officer finishes the current work and becomes available, the incident which has the highest queueing index will then be attended by this officer. Figure 3 illustrates the operation of an accumulating priority queue.

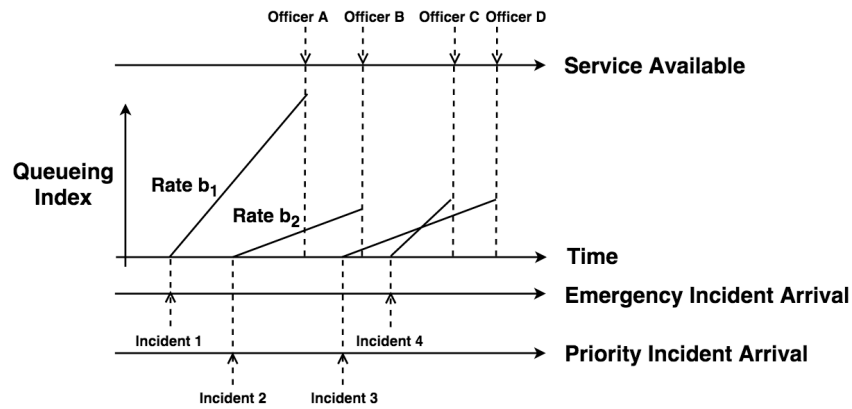

Figure 3 Example of an Accumulating Priority Queue

The upwards arrows in the lower portion of Figure 3 represent the arrival times of four incidents in this example, where incident 1 and incident 4 are emergency incidents; incident 2 and incident 3 are priority incidents. The accumulation rate for emergency incidents, b_1 , is larger than the rate for priority incidents b_2 . The downwards arrows in the lower portion of Figure 3 indicate the time points when there is a patrol officer available to attend an incident waiting for service. Whenever there is an available patrol officer, this patrol officer will attend the incident which accumulates the highest queueing index at this moment. For example, at the time that officer C is available, incident 3 and incident 4 are still waiting to be responded to. Although incident 4 arrived later than incident 3, officer C is assigned to attend incident 4 because incident 4 has a higher queueing index at this moment. Similar to the dispatch of officer C, officer A, B and D are assigned to attend incident 1, 2 and 3, respectively.

The accumulation rates, b_1 and b_2 , do not directly influence the service sequence, but their ratio. Assume the accumulation rate for emergency incidents b_1 is 1, the priority incident accumulation rate b_2 should take values between 0 to 1 since more service resources are dispatched to deal with emergency incidents in practice. This accumulating priority algorithm is applied to simulate police patrol service systems with time varying arrivals. Figure 4 summarizes the simulated police patrol service systems when taking different values of b_2/b_1 .

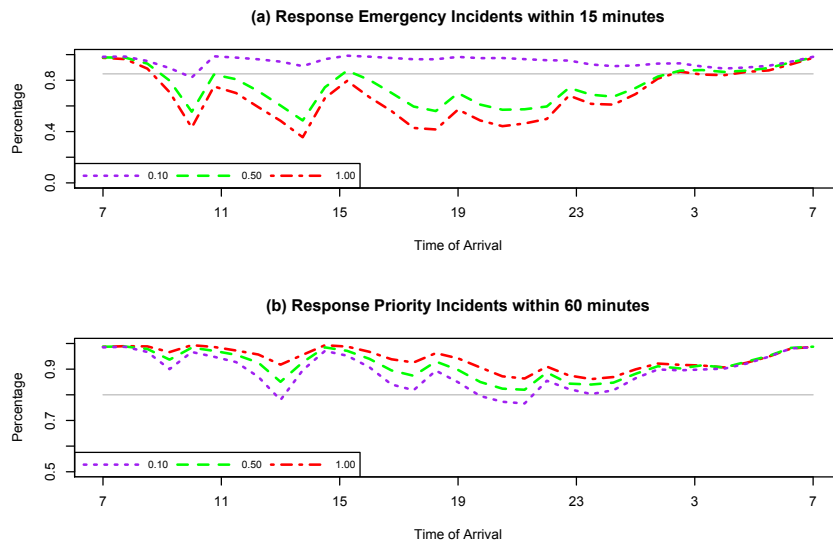

Figure 4 Proportion of Emergency Incidents (a) and Priority Incidents (b) Responded within Targets

Using the Accumulating Priority Queue When $b_2/b_1 = 0.1, 0.5$ and 1.0

Due to the staff unavailability at 10:00, 14:00 and 20:00, the simulation fails to meet the set targets (more than 85% emergency incidents are responded to within 15 minutes and 80% priority incidents are responded to within 60 minutes) no matter how the value of b_2/b_1 changes as shown in Figure 4. When $b_2/b_1 = 1.00$, as shown in the dot-dashed line, the accumulation rate for priority incidents is the same as the rate for emergency incidents, so this priority queue degenerates into a first come first serve queue. As the value of b_2/b_1 decreases, emergency incidents have more advantage in being responded to than priority incidents. Comparing $b_2/b_1 = 0.50$ in the dashed line to $b_2/b_1 = 0.10$ in the dotted line, a conclusion could be drawn that the value of b_2/b_1 does not have a big impact on the service for priority incidents, but the service for emergency incidents is largely improved when b_2/b_1 decreases. A paired-t test is performed to compare service quality change between emergency incidents and priority incidents. The data for the paired-t test are summarized in Table 3. With a t-statistic of 8.08 and the degree of freedom of 23, the p-value of this paired-t test is smaller than 0.01% which confirms the above conclusion.

Table 3 Paired-t Test Data for Service Quality Change from $b_2/b_1 = 0.50$ to $b_2/b_1 = 0.10$

| Time | Respond to Emergency Incidents within 15 minutes | | | | Respond to Priority Incidents within 60 minutes | | | |
|---------------|--|-----------------|---------------------|-------------------|---|-----------------|---------------------|-------------------|
| | from $b_2 = 0.50$ | to $b_2 = 0.10$ | Absolute Difference | Percentage Change | from $b_2 = 0.50$ | to $b_2 = 0.10$ | Absolute Difference | Percentage Change |
| 07:00 - 08:00 | 97.81% | 98.30% | 0.49% | 0.50% | 98.75% | 98.51% | 0.24% | 0.24% |
| 08:00 - 09:00 | 97.65% | 98.48% | 0.83% | 0.83% | 98.82% | 98.70% | 0.12% | 0.13% |
| ... | ... | ... | ... | ... | ... | ... | ... | ... |
| 06:00 - 07:00 | 93.95% | 94.50% | 0.55% | 0.57% | 98.29% | 98.10% | 0.19% | 0.20% |

3.2 Threshold Priority Queues

In queue length ratio based threshold priority queues, choices of service sequence are based on incident queue length ratio of different urgency grades. Incidents of certain urgency grade which exceeds its threshold queue length ratio the most will get the next service resource. Define the priority incident queue length ratio, r , as the ratio of number of waiting priority incidents to amount of total incidents waiting for service.

$$r = \frac{\text{amount of priority incidents waiting for service}}{\text{amount of total incidents waiting for service}} \in (0,1] \quad (3)$$

In the simulation model of patrol police service system, there are only two urgency grades of incidents. The emergency incident queue length ratio can be denoted by $1-r$. Once the queue length ratio of priority incidents r exceeds the threshold value r_0 , the next available officer will attend the incident at the head of the priority queue; otherwise, this officer will be allocated to the incident at the head of the emergency queue. Figure 5 is a graphical illustration of this queue length ratio based threshold priority queue.

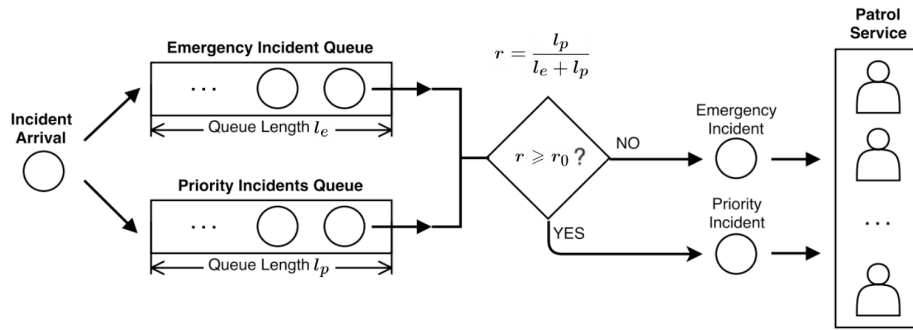

Figure 5 Example of a Threshold Priority Queue

Since 70% of incidents require priority response and emergency incidents should at least have the same priority to access to services, only the queue length threshold ratio r_0 of the value no less than 0.70 will be discussed. Figure 6 presents the simulation results. The percentages of successful emergency responses within 15 minutes are shown in Fig 6a and the percentages of successful priority response within 60 minutes are shown in Fig 6b, where r_0 is set to 1.00, 0.90, 0.80 and 0.70 using a solid line, dotted line, dashed line and dot-dashed line, respectively.

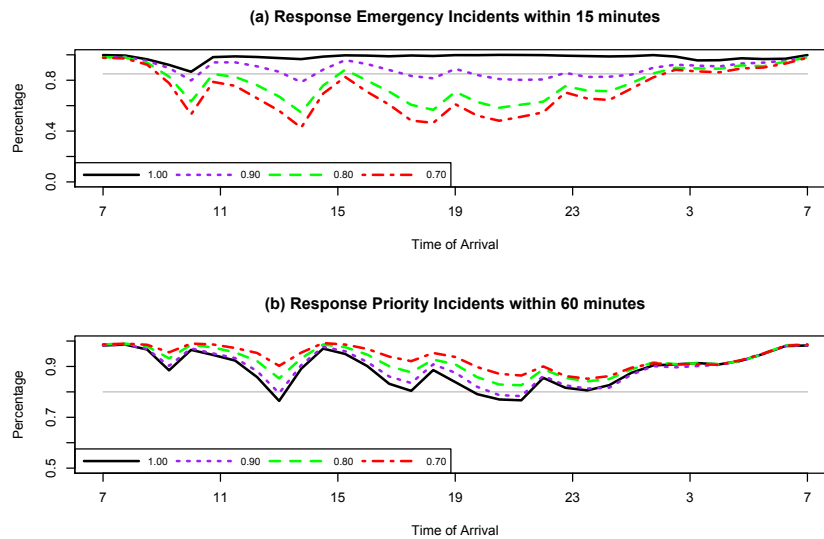

Figure 6 Proportion of Emergency Incidents (a) and Priority Incidents (b) Responded within Targets Using the Accumulating Priority Queue When $r_0 = 1.00, 0.95$ and 0.90

There is no significant difference in responding to priority incidents when taking different values of the threshold queue ratio r_0 . The best performance is obtained when the ratio r_0 is 1.00, which corresponds to static priority queue. Comparing these four lines, the simulation results indicate that with an increase in the value of the queue length threshold ratio r_0 , the effect of the under-staffing in responding to emergency incidents decreases. The service target for emergency incidents is achieved when $r_0 = 1.00$ and the percentage of successful responded to emergency incidents is around 85% when $r_0 = 0.90$ regardless of the occurrence of under-staffing periods at 14:00, 18:00 and 21:00. Paired-t tests with all the p-values less than 0.01% confirm that emergency response service quality is more sensitive to the change of r_0 . Table 5 summaries percentage changes of service quality as the data for the paired-t tests.

Table 5 Average Percentage Service Quality Change for Paired-t Test

| r_0 | Percentage change in Respond to Emergency Incidents within 15 minutes | | | | Percentage change in Respond to Priority Incidents within 60 minutes | | | |
|-------|---|--------|--------|--------|--|-------|-------|-------|
| | from to | 0.70 | 0.80 | 0.90 | 1.00 | 0.70 | 0.80 | 0.90 |
| 0.70 | — | 10.75% | 30.10% | 46.06% | — | 1.79% | 4.17% | 5.23% |
| 0.80 | 9.24% | — | 16.52% | 30.31% | 1.85% | — | 2.54% | 3.61% |
| 0.90 | 20.49% | 13.07% | — | 11.13% | 4.47% | 2.64% | — | 1.44% |
| 1.00 | 27.43% | 20.92% | 9.59% | — | 5.76% | 3.84% | 1.48% | — |

3.3 Discussion

In both the accumulating priority queues and the threshold priority queues, emergency responses are more sensitive than the priority responses to the parameter values. A possible explanation is that the service target for emergency incidents is stricter and more difficult to be achieved. Even when the accumulation rate is set to 0.1 in the accumulating priority queue, the service target for responding to emergency incidents fails to be met at about 10:00. The rest, 70% of total simulated incidents, are priority incidents which occupy the major part of the patrol service resource.

The best service for emergency incidents is obtained when performing static priority queue which is a special case of threshold priority queue with the queue length ratio threshold $r_0 = 1.00$. The accumulating priority queues with the accumulation rate ratio $b_2/b_1 = 0.10$ approximates the behavior of static priority queues by assigning emergency incidents a large accumulation rate. A reasonable assertion can be made that with a large enough accumulation rate ratio b_2/b_1 , the accumulating priority queue will eventually become a static priority queue. The best service for priority incidents is obtained when performing a accumulating priority queue with the accumulation rate ratio $b_2/b_1 = 1.00$. It is exactly a first come first serve queue regardless of urgency grades, the simulated service system meets the priority incident service target with sacrificing the service quality of the emergency incidents.

Compared with emergency incidents, police service quality of priority responses is not sensitive to the parameter values, static priority queues which always give priority to respond to emergency incidents is preferable for police patrol operations. No matter how the values of parameters change, the service targets for incidents in both the urgent grades cannot be met at the same time because of a lack of staff. More staff should be added into the system for a better service.

4 CONCLUSION AND FUTURE WORK

In this paper, we compare two types of priority queues, the accumulating priority queue and the threshold priority queue, for real time deployment of patrol officers in police patrol service system. Although dynamic priority queues seem to perform better in aligning service resources to service targets for a multi-priority system, traditional static priority queue still provides an efficient way to set the service sequence when the service target from the higher urgency grade is hard to achieve in moderate under-staffed periods.

All results are subject to change depending on the simulation input parameters, such as the patrol officer service rates, the travel time and the number of staff on each shift. An obvious extension of current simulation models is that the required service resource may vary with the nature of incidents. For example, a road related incident may require two patrol officers to attend at the same time but to attend a serious street fighting incident may require more patrol officers to work together. Due to differences in patrol policies, in some police area the graphical factors may also influence the service targets. According to Nottinghamshire Police HQ(2015), the service target for emergency incidents is 20 minutes in rural area and 15 minutes in urban area. Since most police cars are equipped with GPS in the UK, with the GPS

information of available patrol officers patrol activity dispatchers in the police force is able to contact the most efficient police officer to attend incidents and an improvement in service could be expected. Combined with integer programming models, the simulation will be able to indicate more effective staffing levels.

REFERENCES

- Choi B and Chang Y (1999). Single server retrial queues with priority calls. *Mathematical and Computer Modelling* **30(3)**: 7-32.
- Gurvich I and Whitt W(2010). Service-level differentiation in many-server service systems via queue-ratio routing. *Operations Research* **58(2)**: 316-328.
- Hay A M, Valentin E C and Bijlsma R (2006). Modeling emergency care in hospitals: a paradox-the patient should not drive the process. In: Perrone L F, Wieland F P, Liu J, Lawson B G, Nicol D M and Fujimoto R M (eds). *Proceedings of the 2006 Winter Simulation Conference*. INFORMS: California, US, pp 439-445.
- Henderson S G and Mason A J (2004). Ambulance service planning: simulation and data visualisation. *Operations Research and Health Care*, pp 77-102. Springer.
- Jennings O B, Mandelbaum A, Massey W A and Whitt W (1996). Server staffing to meet time-varying demand. *Management Science*, **42(10)**: 1383-1394.
- Kleinrock L (1964). A delay dependent queue discipline. *Naval Research Logistics Quarterly*, **11(3-4)**: 329-341.
- Kleinrock, L and Finkelstein R P (1967). Time dependent priority queues. *Operations Research*, **15(1)**: 104-116.
- Knessl C, Tier C and II Choi D (2003). A dynamic priority queue model for simultaneous service of two traffic types. *Journal on Applied Mathematics*, **63(2)**: 398-422.
- Leicestershire Police (2013). *Incident Response Policy*. https://leics.police.uk/media/uploads/library/file/Incident_Response_Policy_-_PO078.0.pdf. accessed 30-September-2015.
- Metropolitan Police (2013). *Average response time for 999 calls by urgency*. Technical report.
- Nottinghamshire Police HQ(2015). *Request under the Freedom of Information Act 2000 (FOIA)*. <http://www.nottinghamshire.police.uk/sites/default/files/documents/files/FOI%20005534%2015.pdf>
- Perry O and Whitt W (2013). Achieving rapid recovery in an overload control for large-scale service systems. *Stochastic Systems* advance online publication 29 July, arXiv:1301.4713.
- Ridley A D, Fu M C and Massey W (2003). Fluid approximations for a priority call center with time-varying arrivals. In: Chick S, Sdnchez P J, Ferrin D, and Morrice D J (eds). *Proceedings of the 2003 Winter Simulation Conference*. INFORMS: Los Angeles, US, pp 1817-1823.
- Sharif A B, Stanford D A, Taylor P and Ziedins I (2014). A multi-class multi-server accumulating priority queue with application to health care. *Operations Research for Health Care*, **3(2)**: 73-79.
- Stanford D A, Taylor P and Ziedins I (2014). Waiting time distributions in the accumulating priority queue. *Queueing Systems*, **77(3)**: 297-330.

AUTHOR BIOGRAPHIES

HANJING ZHANG is a PhD student in Operational Research at Loughborough University. She is working on an inter-departmental project which focusing on developing combined simulation and optimisation models that can be used to support optimal staff allocation in the local police force. Home page: <http://www.lboro.ac.uk/departments/sbe/staff/profiles/phdprofiles/zhanghanjing/zhang-hanjing.html>

Zhang, Jackson, Tako, and Liu

LISA JACKSON is a Senior Lecturer in Risk and Reliability at Aeronautical and Automotive Engineering Department, Loughborough University. She is also a principal investigator for the ESRC sponsored project on Demand Modelling and Predictive Positioning of Police Patrol Officers: a project investigating effective use of police patrol officers to maximise availability for crime response. Home page: <http://www.lboro.ac.uk/departments/aae/about/staff/dr-lisa-jackson.html>

ANTUELA A. TAKO is a Lecturer in Operational Research at the School of Business and Economics, Loughborough University. She holds a PhD in Simulation and an MSc in Management Science and Operational Research from the University of Warwick. Her research interests include the comparison of simulation approaches (discrete-event simulation and system dynamics), facilitated and participative simulation modelling and conceptual modelling. She is an Associate Fellow of the Operational Research Society. Home page: www.lboro.ac.uk/departments/sbe/staff/profiles/takoantuela/tako-antuelanthi.html.

JYIN LIU is a Professor of Operations Management at Loughborough University School of Business and Economics. He received his PhD in manufacturing engineering and operations management from University of Nottingham. His research interests include modelling and optimisation of operations planning and scheduling problems in industrial and service systems. He has published widely. His research papers appeared in academic journals such as *European Journal of Operational Research*, *IEEE Transactions*, *IIE Transactions*, *International Journal of Production Research*, *Journal of the Operational Research Society*, *Naval Research Logistics*, *Operations Research* and *Transportation Research*. Home page: <http://www.lboro.ac.uk/departments/sbe/staff/profiles/liujiyin/liu-jiyin.html>

RESPONSE TO THE REVIEW COMMENTS

We are pleased to resubmit our paper “A simulation of a police patrol service system with multi-grade time-varying incident arrivals” for SW16 conference. We are very thankful to the reviewers for their constructive comments. The paper has been revised in the light of these comments. Responses to these comments are provided below:

Reviewer 1

Comment 1: From my previous knowledge, targets for police attendance used to be split into urban and rural areas, where the target for ‘flash’ calls for urban was 8mins, while rural was 20mins (for Kent Police in 1997).

Response: Thank you for the suggestion. We are aware that different police forces may set a different service target for patrol officers’ attendance. In this paper, we use the national response target which is 15mins for emergency responses. The same target is also used in Leicestershire Police. As far as we are aware, Kent Police Force has not set targets for attendance times since autumn 2012 but that they aim to attend calls as quickly and safely as possible. Nottinghamshire Police set the emergency response target to be 15mins in urban areas and 20mins in rural areas. We also explain in section 4 (conclusion and future work) that the results of the simulation model are subject to change .

Comment 2: There are a few typos in the paper need correcting.

Response: The paper has been checked to to improve the spelling .

Comment 3: Figure 3 could be better explained.

Response: Some sentences have been added in the second paragraph of section 3.1 to explain Figure 3.

Reviewer 2

Comment: My only suggestion concerns a grammatical issue that arises throughout this paper. The definite article ‘the’, is frequently used when it is unnecessary and often when its use is actually incorrect, thereby giving a misleading emphasis to what is being said.

Response: The entire paper has been checked and the unnecessary instances of using ‘the’ article have been removed.