

Temperature Dependence of Kerr Constant for Water at 658 nm and for Pulsed Intense Electric Fields

Bucur M. Novac, *Senior Member, IEEE*, Robert Ruscassié, Meng Wang, *Student Member, IEEE*, Antoine Silvestre De Ferron, Laurent Pécastaing, Ivor R. Smith, *Senior Member, IEEE*, and Jiahui Yin

Abstract—The temperature dependence of the Kerr constant for water has been determined over the range 19 °C–45 °C at a wavelength of 658 nm. This paper presents the experimental arrangement used for this purpose and the data obtained, for which a polynomial fit is provided. A formula is also suggested to help estimate the variation of the Kerr constant for water with both temperature and wavelength.

Index Terms—Electrooptic devices, Kerr effect, pulsed electric field (PEF).

I. INTRODUCTION

THERE are a number of applications for which the intense pulsed electric fields generated inside liquids during pulsed power experiments are required to be accurately known, sometimes in volumes where access is limited. The usual technique is to measure the voltage between two metallic electrodes immersed inside the liquid and to calculate the resulting electric field using either an electrostatic solver (such as ANSYS Maxwell [1] or Quickfield [2]) or a complex electromagnetic software (such as CST EM Studio [3]). The problem is that under transient high electric stress, although the numerical results are, in principle, very accurate, various unaccountable breakdown phenomena may occur inside the liquid. These phenomena are usually difficult to predict and implement into the calculations, which makes direct measurement of the electric field the only practical solution. Such a measurement inside a liquid is only possible using electrooptic diagnostics based on either the Pockels effect [4] or the Kerr effect [5]. The Pockels effect uses a crystal as an active medium and, therefore, the probe must be calibrated

when inserted in the liquid, while the Kerr effect uses the liquid itself as an active medium, making the measurement extremely convenient. This paper deals with the measurement of the Kerr effect in water.

Kerr effect measurements of electric fields can be implemented to give valuable *in situ* information for a number of high-voltage pulsed power systems. These include water-filled pulse forming lines, closing switches operated under water, and monitoring the pulsed electric field in pulsed electric field (PEF) equipment used either for food processing or in medical and biological applications. In [5], the main technical issues related to measuring the Kerr effect in water were highlighted and it was demonstrated that, in most cases, the values of the published Kerr constant are at best unreliable.

There are, however, two supplementary issues, not covered by previous work, that relate to the variation of the Kerr constant with temperature and pressure.

In practical applications, the temperature is either deliberately kept higher than room temperature, as in PEF processing machines, or simply the measurements with the pulsed power systems take place at an ambient temperature that is dependent on the season. Detailed theoretical considerations of the Kerr effect in liquids are complicated and outside the scope of this paper, but useful estimations can be made using the Born formula [5]

$$B = \frac{n^2 + 2}{\lambda n} (\epsilon_r + 2)^2 N \Theta \quad (1)$$

where n is the refractive index of the liquid, ϵ_r its static dielectric constant, N the number of molecules per unit volume, Θ a complex function depending on the liquid temperature T and its polarizability, and λ is the light wavelength. As the formula shows, the temperature dependence of the Kerr constant B is complex, because n and Θ both vary with temperature. It is well beyond the aim of this paper to discuss these complicated theoretical matters in detail.

The aim of the work described is to provide a reliable measurement of the temperature variation of the Kerr constant for water between 19 °C and 45 °C, the temperature interval mostly used in the above-mentioned applications. The literature for this subject is scarce and in the limited number of sources that are available [6]–[8], the data are sometimes unreliable, for reasons previously detailed [5].

Manuscript received September 18, 2015; revised February 4, 2016 and March 31, 2016; accepted April 18, 2016.

B. M. Novac, M. Wang, and I. R. Smith are with the Wolfson School of Mechanical, Electrical and Manufacturing Engineering, Loughborough University, Loughborough LE11 3TU, U.K. (e-mail: b.m.novac@lboro.ac.uk; m.wang4@lboro.ac.uk; i.r.smith@lboro.ac.uk).

R. Ruscassié, A. S. De Ferron, and L. Pécastaing are with the Laboratoire des Sciences de l'Ingénieur Appliquées à la Mécanique et au Génie Electrique, Equipe Génie Electrique, Université de Pau et des Pays de l'Adour, Pau 64053, France (e-mail: robert.ruscassie@univ-pau.fr; antoine.deferron@univ-pau.fr; laurent.pecastaing@univ-pau.fr).

J. Yin is with the School of Mechanical, Electrical and Manufacturing Engineering, Loughborough University, Loughborough LE11 3TU, U.K., on leave from the Northwest Institute of Nuclear Technology, Xi'an 710024, China (e-mail: yinjiahui@nint.ac.cn).

Color versions of one or more of the figures in this paper are available online at <http://ieeexplore.ieee.org>.

Digital Object Identifier 10.1109/TPS.2016.2558470

The pressure variation of B is more complicated than its temperature dependence and is not discussed in the literature. However, as explained [5], theoretical predictions for the pressure (P) dependence of the dielectric constant $\epsilon_r = \epsilon_r(P)$ suggest important variations at a pressure above 200 Mbar. Such a pressure will certainly affect the measurement and can be generated by strong shock waves due to electrical breakdown inside microscopic air bubbles that may be present in water. The Kerr cell developed for studying the temperature variation of the Kerr constant cannot be pressurized and the authors are confident that there are no physical processes present inside the liquid in a Kerr cell that can generate pressures of the order of 200 Mbar or higher. The electric breakdown inside microscopic air bubbles, if present, is controlled by the electric field intensity. Hundreds of tests performed for the work reported in [5] showed that, even when strong electric fields up to 360 kV/cm are generated, the Kerr constant remained unchanged. The conclusion is that if microscopic air bubbles are indeed present, they do not influence the results obtained. If shock waves are on purpose generated to produce high pressures, the technique will not provide reliable results. In preliminary testing with one of the first Kerr cells [5], shock waves were generated inside the liquid by accidental electrical breakdown, strongly disturbing the laser light beam and making the recording difficult to interpret.

Taking all the above features into account, the pressure dependence in the tests performed for this work is completely neglected.

As a final comment, the Kerr constant can also be influenced by the frequency f of the electric field. Fortunately, for most liquids including water, the dispersion of the dielectric constant $\epsilon_r = \epsilon_r(f)$ remains constant up to about 1 GHz.

II. EXPERIMENTAL ARRANGEMENT

The experimental arrangement, presented in Figs. 1 and 2, is similar to that used in previous Kerr experimentation [5], [9]. A $\lambda = 658\text{-nm}$ laser launches a light beam through a water-filled Kerr cell maintained at a constant temperature by a water bath surrounding the cell. The temperature inside the cell is accurately measured using a thermocouple immediately before and after each test. The water inside the cell is both purified and heated by a system comprising a pump, a filter, and a heating resistance. The authors have not studied the variation of the Kerr constant with water salinity or when additives are present. However, demineralized water (resistivity $33\text{ k}\Omega \cdot \text{cm}$) and tap water (resistivity between $4\text{ k}\Omega \cdot \text{cm}$ and $5\text{ k}\Omega \cdot \text{cm}$) used in previous experiments [5] provided identical results.

The Kerr cell described in [5] uses a pair of 400-mm long parallel-plate stainless-steel electrodes held $d = 5.00 \pm 0.05\text{ mm}$ apart with the aid of a polyethylene support. For the present work, however, the material for the support was changed to Polymethylmethacrylate, having a thermal expansion coefficient of about $70 \times 10^{-6}/^\circ\text{K}$, so that even a $20\text{ }^\circ\text{C}$ temperature increase will cause only a $7\text{ }\mu\text{m}$ increase of the 5 mm initial separation measured at $25\text{ }^\circ\text{C}$, representing a change of 0.14%. The cell was

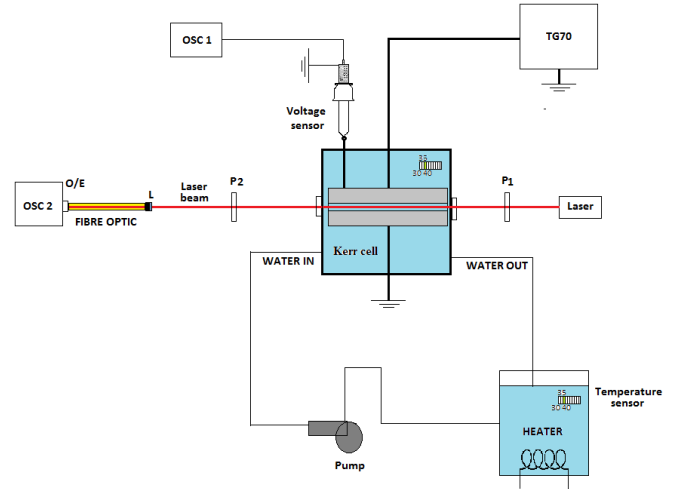

Fig. 1. Practical arrangement for Kerr experiments, with the main elements listed below: *Electrical*: TG70 is a pulsed voltage generator connected to the Kerr cell electrodes, with the high-voltage sensor attached to an oscilloscope (OSC 1). *Optics*: a battery-operated laser launches the light into the Kerr cell, with P1 and P2 being two crossed polarizers and L a collimating lens connected to a optical fiber; O/E represents an optoelectronic convertor attached to an oscilloscope (OSC 2). *Water system*: a heated water tank (heater) is connected through a pump and filter (not shown) to the Kerr cell.

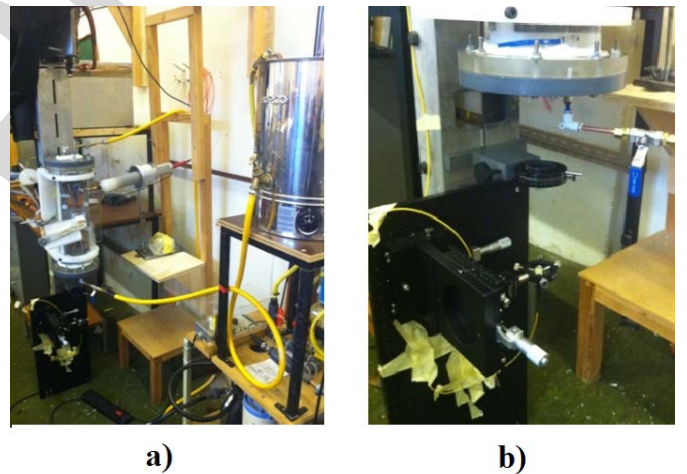

Fig. 2. Experimental assembly. (a) Overall view of the Kerr cell with high-voltage sensor and water heating tank. (b) Detail showing a polarizer and the high-precision mechanical components used to align the collimator lens.

mounted vertically to encourage air bubbles to surface easily. The transient electric field $E(t)$ was generated between the cell electrodes by the application of a voltage impulse from a high-voltage trigger generator type TG-70 (L-3 Applied Technologies [10]). The corresponding time-varying light intensity $I(t)$ detected by an optoelectronic converter can be predicted from [5]

$$I(t) = I_{\max} \sin^2 \left(\frac{\delta(t)}{2} \right) = I_{\max} \sin^2 \left(\frac{\pi B l' V^2(t)}{d^2} \right) \quad (2)$$

where I_{\max} is the maximum light intensity, δ the retardation between the two electric field components of the linearly polarised light, and $l' = d^2 \int_0^l E(x)^2 dx$ the effective optical path length, calculated for the present cell using

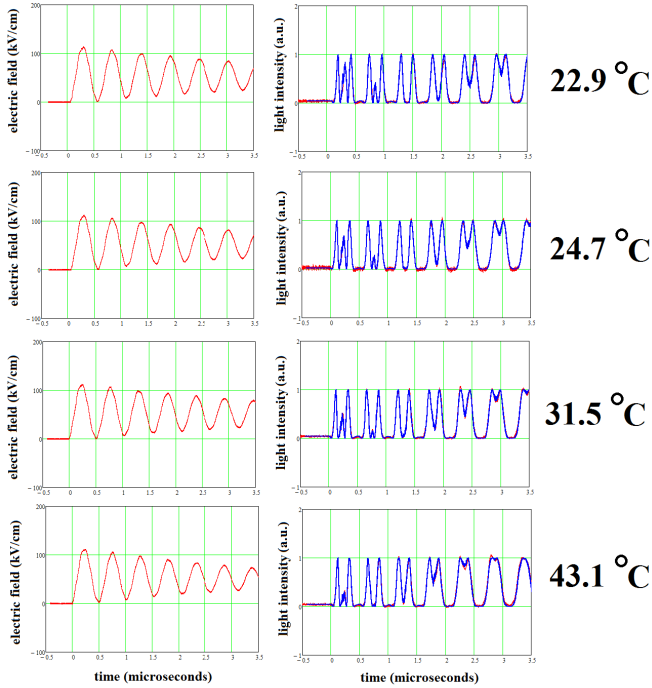

Fig. 3. Typical oscilloscope recordings at various temperatures. Left column: the train of electric field impulses applied between the Kerr cell electrodes, derived from the voltage signal. Right column: the corresponding recorded optical signals (blue lines). Qualitatively, a decrease in the Kerr constant for higher water temperatures is clearly indicated by a reduced number of light oscillations. Theoretical predictions (red lines) using (1) and voltage data are practically indistinguishable, demonstrating that no external interference has disturbed the tests.

3-D ANSYS Maxwell software as $l' = 404.11$ mm. The voltage $V(t)$ applied to the Kerr cell electrodes was measured using a North Star voltage probe type PVM 6 [11], mounted in a way different from that used in [5], a technique adopted to simplify data interpretation and improve the precision of the measurement (see the Appendix). The voltage probe used in the tests has an accuracy guaranteed by the manufacturer of less than 1.5% and the authors used a similar probe kept as a reference to check the calibration, before performing experiments with the new Kerr arrangement.

III. RESULTS

In each test, a reproducible train of pulsed electric fields with a maximum peak exceeding 100 kV/cm was applied between the Kerr cell electrodes, while from test to test the water temperature was varied between 292 K (19 °C) and 318 K (45 °C). Due to presently not well-understood phenomena (accumulation of air bubbles, water turbulence, etc.), higher temperature shots do not provide reliable data. Typical experimental results are shown in Fig. 3.

The technique used to analyze the results was presented previously [5]. Briefly, B is calculated only at certain points, i.e., voltage (i.e., electric field) peaks, where the precision is the highest. The fact that in Fig. 3 the trace provided by formula is practically indistinguishable from the real light trace is not related to any precision, as this information is not used in the measurement of the Kerr constant. It only serves to

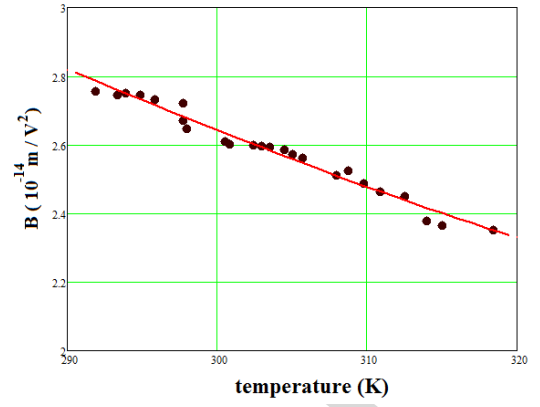

Fig. 4. Temperature dependence of the Kerr constant for water at 658 nm. Full circles are experimental data while the line represents a temperature polynomial fit (see text).

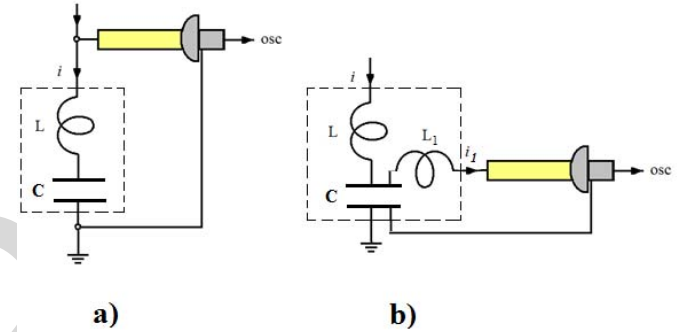

Fig. 5. Alternative ways of mounting the voltage sensor to measure the voltage impulse applied to a Kerr cell, represented by the dotted rectangle.

demonstrate that there is no external interference disturbing the actual test. The measurement of the Kerr constant is, however, affected by the following errors [5]:

$$\frac{\Delta B}{B} = \pm \frac{\Delta \delta(t)}{\delta(t)} \pm 2 \frac{\Delta d}{d} \pm \frac{\Delta l'}{l'} \pm 2 \frac{\Delta V(t)}{V(t)}. \quad (3)$$

The detailed analysis [5] is perfectly applicable to the present work and shows the total error for each right-hand side term is, respectively, $\pm 2\%$, $\pm 3\%$, $\pm 1\%$, and $\pm 3\%$, resulting in a very conservatively estimated total error of less than $\pm 10\%$. It is important to note that the statistical scatter for many identical experiments is always much less than this.

As expected, the Kerr constant B is affected by the temperature T and, for the data points in Fig. 4, the best polynomial interpolation (presented in a form similar to that used in previous work [6]–[8]) was found as

$$\frac{B(T, \lambda_{\text{ref}})}{B(T_{\text{ref}}, \lambda_{\text{ref}})} = \sum_{k=0}^3 \frac{A_k}{T^k} \quad (4)$$

where the result is normalized to the Kerr constant $B(T_{\text{ref}}, \lambda_{\text{ref}}) = 2.746 \cdot 10^{-14}$ (m/V²) at an arbitrarily chosen reference temperature of $T_{\text{ref}} = 294$ K, with $\lambda_{\text{ref}} = 658$ nm. The four polynomial constants are

$$\begin{aligned} A_0 &= 12.59900; & A_1 &= -1.16036 \cdot 10^4 \text{ K} \\ A_2 &= 3.65080 \cdot 10^6 \text{ K}^2 & A_3 &= -3.65043 \cdot 10^8 \text{ K}^3. \end{aligned}$$

The nonlinear least-squares fit mathematical procedure used in obtaining the four constants provided a correlation coefficient of 0.987 with a confidence level of 0.99. The error in calculating B using (4) is conservatively estimated as $\pm 10\%$.

IV. CONCLUSION

This paper has accurately defined the Kerr constant for water for a range of temperatures between 19 °C and 45 °C. When Kerr sensors use laser wavelengths λ slightly different from that of this paper, the appropriate Kerr constant can be estimated with $\pm 10\%$ error from

$$B(T, \lambda) \approx B(T_{\text{ref}}, \lambda_{\text{ref}}) \frac{\lambda_{\text{ref}}}{\lambda} \sum_{k=0}^3 \frac{A_k}{T^k}. \quad (5)$$

The results obtained represent an important step in the development of a reliable and accurate pulsed electric field measurement technique. It is of particular value for PEF treatment systems and in general for water-filled HV pulsed power components such as transmission lines, capacitors, and spark gaps.

APPENDIX

Fig. 5 presents two ways in which a voltage sensor can be mounted to measure the voltage impulse applied across the Kerr cell capacitance C .

- 1) In this case, a current i having a high time rate-of-change di/dt flows through the cell and, therefore, the voltage across C is different from that measured by the voltage sensor, which includes the supplementary inductive term $L \cdot di/dt$. To obtain the required result, a correction must be made, as indicated in [5].
- 2) In this case, the connection between the sensor and the Kerr cell has a low value of self-inductance L_1 and, due to the high-impedance of the sensor, the time rate-of-change of the current i_1 is extremely small and the inductive voltage term $L_1 \cdot di_1/dt$ is consequently negligible. In this case, the sensor measures accurately the voltage across C and no corrections are required.

Another voltage measurement issue is related to the inductive effects introduced by the self-inductance of the connection to ground. To minimize as much as possible the parasitic inductance between the ground and the lower plate of the Kerr cell capacitor, a wide (300 mm) and relatively short (less than 0.8 m) copper sheet was used. The laboratory ground is a large area (many square meters) of thin copper layer covered by wooden plates for protection and connected to a purpose-made low-resistance ground situated in the immediate vicinity of the pulsed power laboratory where experiments took place.

REFERENCES

- [1] ANSYS Maxwell, accessed on Sep. 2015. [Online]. Available: <http://www.ansys.com/Products/Simulation+Technology/Electronics/Electromechanical/ANSYS+Maxwell>
- [2] Quickfield, accessed Sep. 2015. [Online]. Available: <http://www.quickfield.com/>
- [3] CST EM Studio, (accessed Sep. 2015). [Online]. Available: <https://www.cst.com/Products/CSTEMS>

- [4] G. Gaborit *et al.*, "Single shot and vectorial characterization of intense electric field in various environments with pigtailed electrooptic probe," *IEEE Trans. Plasma Sci.*, vol. 42, no. 5, pp. 1265–1273, May 2014.
- [5] B. M. Novac *et al.*, "Determination of the Kerr constant of water at 658 nm for pulsed intense electric fields," *IEEE Trans. Plasma Sci.*, vol. 40, no. 10, pp. 2480–2490, Oct. 2012.
- [6] Y.-J. Chen and W. H. Orttung, "Temperature dependence of the Kerr constant of water," *J. Phys. Chem.*, vol. 76, no. 2, pp. 216–221, 1972.
- [7] R. K. Khanna, E. Dempsey, and G. P. Jones, "Kerr constant of water from 280 to 350 K at 632.8 nm," *Chem. Phys. Lett.*, vol. 53, no. 3, pp. 542–544, 1978.
- [8] R. E. Hebner, Jr., R. J. Sojka, and E. C. Cassidy, "Kerr coefficients of nitrobenzene and water," Nat. Bureau Standards, Boulder, CO, USA, Final Rep. AFWL-TR-76-117, 1976.
- [9] B. M. Novac *et al.*, "Demonstration of a novel pulsed electric field technique generating neither conduction currents nor Joule effects," *IEEE Trans. Plasma Sci.*, vol. 42, no. 1, pp. 216–228, Jan. 2014.
- [10] L3 Applied Technologies, accessed on Sep. 2015. [Online]. Available: http://www.2.1-3.com/ati/pdfs/PA80_PA100.pdf
- [11] North Star High Voltage, accessed on Sep. 2015. [Online]. Available: <http://www.highvoltageprobes.com>



Bucur M. Novac (M'06–SM'08) received the M.Sc. and Ph.D. degrees from the University of Bucharest, Romania, in 1977 and 1989, respectively.

He joined Loughborough University, Leicestershire, U.K., in 1998, where he is currently a Professor of Pulsed Power. He is a Chartered Engineer with the Institution of Engineering and Technology (IET), Stevenage, U.K. He has co-authored two books on explosive pulsed power and has authored over 200 refereed papers and conference contributions. His current research interests include compact and repetitive high-power systems, explosively and electromagnetically driven magnetic flux compression generators and their applications, electromagnetic launchers, ultrafast magneto and electro-optic sensors, and 2-D modeling of pulsed-power systems.

Dr. Novac is a Voting Member of the Pulsed Power Science and Technology Committee in the IEEE Nuclear and Plasma Science Society. He is also a member of the International Steering Committees for the MEGAGAUSS Conferences and the Euro-Asian Pulsed Power Conferences. He is also a member of the Organizing Committee of the IEEE International Power Modulator and High Voltage Conference and a Co-Chairman of the U.K. Pulsed Power Symposium. He is a fellow of IET.



Robert Ruscassié received the M.Sc. degree in electrical engineering and the Ph.D. degree from Université Montpellier II, Montpellier, France, in 2001 and 2005, respectively.

He is currently a Lecturer and Researcher with the Sciences de l'Ingénieur Appliquées à la Mécanique et au Génie Electrique Laboratory, Université de Pau et des Pays de l'Adour, Pau, France. His current research interests include energy conversion and associated metrology for pulsed power applications.

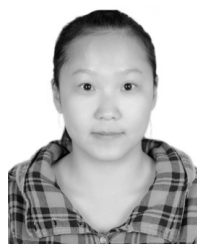

Meng Wang (S'13) was born in China. She received the B.Sc. degree in electronics science and technology from the Huazhong University of Science and Technology, Wuhan, China, in 2011, and the M.Sc. degree in power systems engineering from University College London, London, U.K., in 2012. She is currently pursuing the Ph.D. degree with the Pulsed Power Group, Loughborough University, Leicestershire, U.K. Her Ph.D. project is focused on the development of a 10 GW pulsed power generator and the techniques required to modulate its output.

Her current research interests include compact and repetitive pulsed power, ultrahigh speed sensors, and modeling and analysis of 3-D electromagnetic systems.



Antoine Silvestre De Ferron was born in Tarbes, France, in 1977. He received the Ph.D. degree in electrical engineering from the Université de Pau et des Pays de l'Adour (UPPA), Pau, France, in 2006.

He was a Researcher with the Atomic Energy Commission, Le Barp, France, from 2006 to 2008, a French-government-funded technological research organization. He is currently an Engineer with the Laboratoire Sciences de l'Ingénieur Appliquées à la Mécanique et au Génie Electrique Laboratory, UPPA. His current research interests include high

pulsed power generation for military and civil applications, and combined high-voltage transient probes.



Laurent Pécastaing was born in Bayonne, France, in 1974. He received the Ph.D. degree and the Research Directorship Habilitation degree in electrical engineering from the Université de Pau et des Pays de l'Adour, Pau, France, in 2001 and 2010, respectively.

He is currently a Lecturer with the Laboratoire Sciences de l'Ingénieur Appliquées à la Mécanique et au Génie Electrique Laboratory, Université de Pau et des Pays de l'Adour. His current research interests include high-power microwave sources, compact

pulsed power devices, pulse-forming lines or Marx generators, and ultrafast transient probes.



Ivor R. Smith (M'05–SM'11) received the B.Sc., D.Sc., and Ph.D. degrees from the University of Bristol, Bristol, U.K.

He then became a Lecturer with the University of Birmingham, Birmingham, U.K., where he was promoted to Senior Lecturer and Reader and continued his research contribution. He was a Professor of Electrical Power Engineering, and served as the Head of Department, the Dean of Engineering, and a Pro-Vice Chancellor with Loughborough University, Leicestershire, U.K. He received the indentured student apprenticeship with Witton Works, General Electric, Fairfield, CT, USA. He has been active in research in many aspects of the production, conditioning, and utilization of large pulses of electrical energy, for a span of 25 years. His work has brought in very substantial funding from a variety of sources. He is currently a Chartered Engineer with The Institution of Engineering and Technology, Stevenage, U.K.

Dr. Smith is a fellow of the Royal Academy of Engineering, London, U.K.

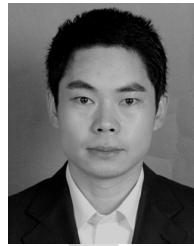

Jiahui Yin received the M.E. degree in nuclear technology and applications from the Northwest Institute of Nuclear Technology, Xi'an, China. He is currently pursuing the Ph.D. degree with the State Key Laboratory of Electrical Insulation and Power Equipment, Xi'an Jiaotong University, Xi'an.

He was with the Northwest Institute of Nuclear Technology in 2000. His current research interests include MV switches and trigger generators.

IEEE PREPRINT

Temperature Dependence of Kerr Constant for Water at 658 nm and for Pulsed Intense Electric Fields

Bucur M. Novac, *Senior Member, IEEE*, Robert Ruscassié, Meng Wang, *Student Member, IEEE*, Antoine Silvestre De Ferron, Laurent Pécastaing, Ivor R. Smith, *Senior Member, IEEE*, and Jiahui Yin

Abstract—The temperature dependence of the Kerr constant for water has been determined over the range 19 °C–45 °C at a wavelength of 658 nm. This paper presents the experimental arrangement used for this purpose and the data obtained, for which a polynomial fit is provided. A formula is also suggested to help estimate the variation of the Kerr constant for water with both temperature and wavelength.

Index Terms—Electrooptic devices, Kerr effect, pulsed electric field (PEF).

I. INTRODUCTION

THERE are a number of applications for which the intense pulsed electric fields generated inside liquids during pulsed power experiments are required to be accurately known, sometimes in volumes where access is limited. The usual technique is to measure the voltage between two metallic electrodes immersed inside the liquid and to calculate the resulting electric field using either an electrostatic solver (such as ANSYS Maxwell [1] or Quickfield [2]) or a complex electromagnetic software (such as CST EM Studio [3]). The problem is that under transient high electric stress, although the numerical results are, in principle, very accurate, various unaccountable breakdown phenomena may occur inside the liquid. These phenomena are usually difficult to predict and implement into the calculations, which makes direct measurement of the electric field the only practical solution. Such a measurement inside a liquid is only possible using electrooptic diagnostics based on either the Pockels effect [4] or the Kerr effect [5]. The Pockels effect uses a crystal as an active medium and, therefore, the probe must be calibrated

when inserted in the liquid, while the Kerr effect uses the liquid itself as an active medium, making the measurement extremely convenient. This paper deals with the measurement of the Kerr effect in water.

Kerr effect measurements of electric fields can be implemented to give valuable *in situ* information for a number of high-voltage pulsed power systems. These include water-filled pulse forming lines, closing switches operated under water, and monitoring the pulsed electric field in pulsed electric field (PEF) equipment used either for food processing or in medical and biological applications. In [5], the main technical issues related to measuring the Kerr effect in water were highlighted and it was demonstrated that, in most cases, the values of the published Kerr constant are at best unreliable.

There are, however, two supplementary issues, not covered by previous work, that relate to the variation of the Kerr constant with temperature and pressure.

In practical applications, the temperature is either deliberately kept higher than room temperature, as in PEF processing machines, or simply the measurements with the pulsed power systems take place at an ambient temperature that is dependent on the season. Detailed theoretical considerations of the Kerr effect in liquids are complicated and outside the scope of this paper, but useful estimations can be made using the Born formula [5]

$$B = \frac{n^2 + 2}{\lambda n} (\epsilon_r + 2)^2 N \Theta \quad (1)$$

where n is the refractive index of the liquid, ϵ_r its static dielectric constant, N the number of molecules per unit volume, Θ a complex function depending on the liquid temperature T and its polarizability, and λ is the light wavelength. As the formula shows, the temperature dependence of the Kerr constant B is complex, because n and Θ both vary with temperature. It is well beyond the aim of this paper to discuss these complicated theoretical matters in detail.

The aim of the work described is to provide a reliable measurement of the temperature variation of the Kerr constant for water between 19 °C and 45 °C, the temperature interval mostly used in the above-mentioned applications. The literature for this subject is scarce and in the limited number of sources that are available [6]–[8], the data are sometimes unreliable, for reasons previously detailed [5].

Manuscript received September 18, 2015; revised February 4, 2016 and March 31, 2016; accepted April 18, 2016.

B. M. Novac, M. Wang, and I. R. Smith are with the Wolfson School of Mechanical, Electrical and Manufacturing Engineering, Loughborough University, Loughborough LE11 3TU, U.K. (e-mail: b.m.novac@lboro.ac.uk; m.wang4@lboro.ac.uk; i.r.smith@lboro.ac.uk).

R. Ruscassié, A. S. De Ferron, and L. Pécastaing are with the Laboratoire des Sciences de l'Ingénieur Appliquées à la Mécanique et au Génie Electrique, Equipe Génie Electrique, Université de Pau et des Pays de l'Adour, Pau 64053, France (e-mail: robert.ruscassie@univ-pau.fr; antoine.deferron@univ-pau.fr; laurent.pecastaing@univ-pau.fr).

J. Yin is with the School of Mechanical, Electrical and Manufacturing Engineering, Loughborough University, Loughborough LE11 3TU, U.K., on leave from the Northwest Institute of Nuclear Technology, Xi'an 710024, China (e-mail: yinjiahui@nint.ac.cn).

Color versions of one or more of the figures in this paper are available online at <http://ieeexplore.ieee.org>.

Digital Object Identifier 10.1109/TPS.2016.2558470

The pressure variation of B is more complicated than its temperature dependence and is not discussed in the literature. However, as explained [5], theoretical predictions for the pressure (P) dependence of the dielectric constant $\epsilon_r = \epsilon_r(P)$ suggest important variations at a pressure above 200 Mbar. Such a pressure will certainly affect the measurement and can be generated by strong shock waves due to electrical breakdown inside microscopic air bubbles that may be present in water. The Kerr cell developed for studying the temperature variation of the Kerr constant cannot be pressurized and the authors are confident that there are no physical processes present inside the liquid in a Kerr cell that can generate pressures of the order of 200 Mbar or higher. The electric breakdown inside microscopic air bubbles, if present, is controlled by the electric field intensity. Hundreds of tests performed for the work reported in [5] showed that, even when strong electric fields up to 360 kV/cm are generated, the Kerr constant remained unchanged. The conclusion is that if microscopic air bubbles are indeed present, they do not influence the results obtained. If shock waves are on purpose generated to produce high pressures, the technique will not provide reliable results. In preliminary testing with one of the first Kerr cells [5], shock waves were generated inside the liquid by accidental electrical breakdown, strongly disturbing the laser light beam and making the recording difficult to interpret.

Taking all the above features into account, the pressure dependence in the tests performed for this work is completely neglected.

As a final comment, the Kerr constant can also be influenced by the frequency f of the electric field. Fortunately, for most liquids including water, the dispersion of the dielectric constant $\epsilon_r = \epsilon_r(f)$ remains constant up to about 1 GHz.

II. EXPERIMENTAL ARRANGEMENT

The experimental arrangement, presented in Figs. 1 and 2, is similar to that used in previous Kerr experimentation [5], [9]. A $\lambda = 658\text{-nm}$ laser launches a light beam through a water-filled Kerr cell maintained at a constant temperature by a water bath surrounding the cell. The temperature inside the cell is accurately measured using a thermocouple immediately before and after each test. The water inside the cell is both purified and heated by a system comprising a pump, a filter, and a heating resistance. The authors have not studied the variation of the Kerr constant with water salinity or when additives are present. However, demineralized water (resistivity $33\text{ k}\Omega \cdot \text{cm}$) and tap water (resistivity between $4\text{ k}\Omega \cdot \text{cm}$ and $5\text{ k}\Omega \cdot \text{cm}$) used in previous experiments [5] provided identical results.

The Kerr cell described in [5] uses a pair of 400-mm long parallel-plate stainless-steel electrodes held $d = 5.00 \pm 0.05\text{ mm}$ apart with the aid of a polyethylene support. For the present work, however, the material for the support was changed to Polymethylmethacrylate, having a thermal expansion coefficient of about $70 \times 10^{-6}/^\circ\text{K}$, so that even a $20\text{ }^\circ\text{C}$ temperature increase will cause only a $7\text{ }\mu\text{m}$ increase of the 5 mm initial separation measured at $25\text{ }^\circ\text{C}$, representing a change of 0.14%. The cell was

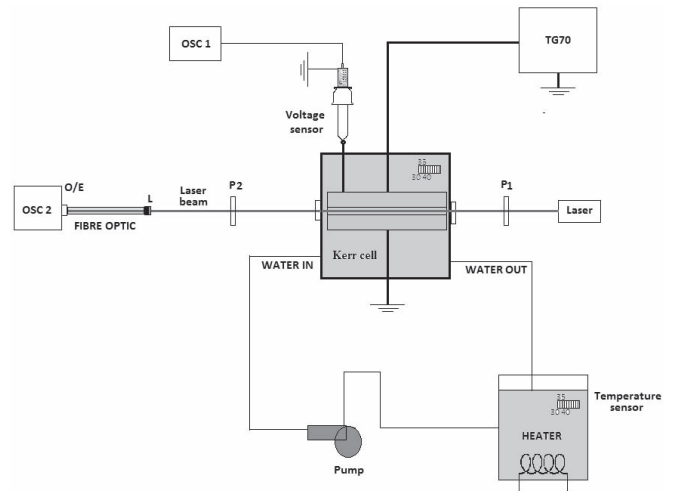

Fig. 1. Practical arrangement for Kerr experiments, with the main elements listed below: *Electrical*: TG70 is a pulsed voltage generator connected to the Kerr cell electrodes, with the high-voltage sensor attached to an oscilloscope (OSC 1). *Optics*: a battery-operated laser launches the light into the Kerr cell, with P1 and P2 being two crossed polarizers and L a collimating lens connected to a optical fiber; O/E represents an optoelectronic convertor attached to an oscilloscope (OSC 2). *Water system*: a heated water tank (heater) is connected through a pump and filter (not shown) to the Kerr cell.

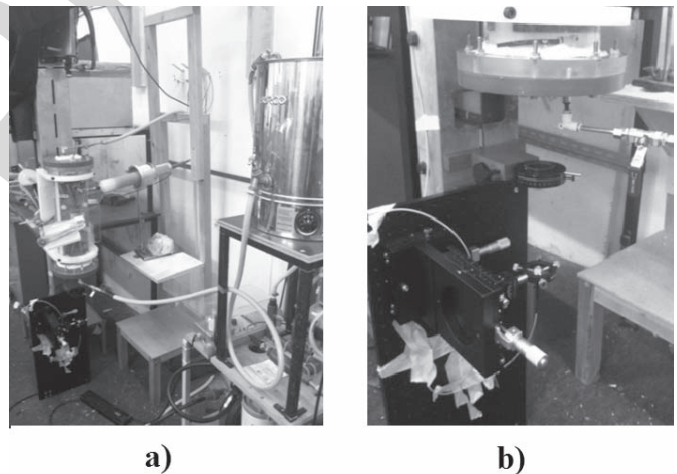

Fig. 2. Experimental assembly. (a) Overall view of the Kerr cell with high-voltage sensor and water heating tank. (b) Detail showing a polarizer and the high-precision mechanical components used to align the collimator lens.

mounted vertically to encourage air bubbles to surface easily. The transient electric field $E(t)$ was generated between the cell electrodes by the application of a voltage impulse from a high-voltage trigger generator type TG-70 (L-3 Applied Technologies [10]). The corresponding time-varying light intensity $I(t)$ detected by an optoelectronic converter can be predicted from [5]

$$I(t) = I_{\max} \sin^2 \left(\frac{\delta(t)}{2} \right) = I_{\max} \sin^2 \left(\frac{\pi B l' V^2(t)}{d^2} \right) \quad (2)$$

where I_{\max} is the maximum light intensity, δ the retardation between the two electric field components of the linearly polarised light, and $l' = d^2 \int_0^l E(x)^2 dx$ the effective optical path length, calculated for the present cell using

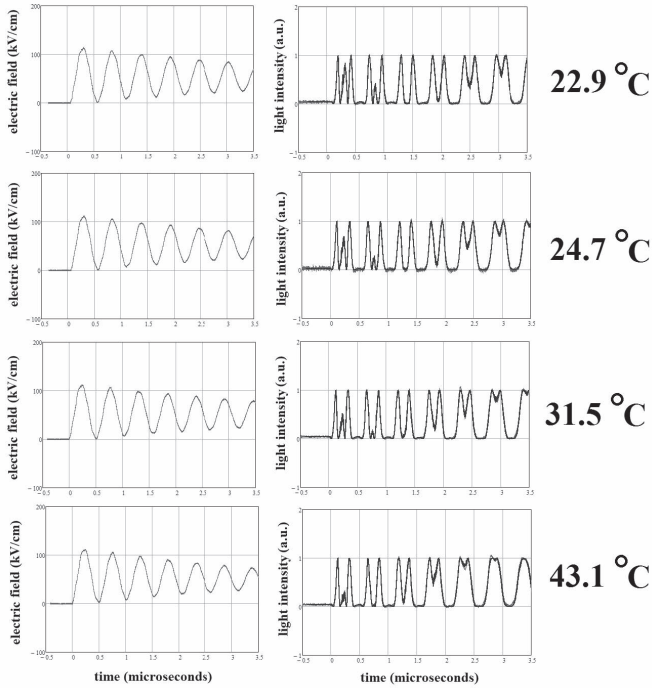

Fig. 3. Typical oscilloscope recordings at various temperatures. Left column: the train of electric field impulses applied between the Kerr cell electrodes, derived from the voltage signal. Right column: the corresponding recorded optical signals (blue lines). Qualitatively, a decrease in the Kerr constant for higher water temperatures is clearly indicated by a reduced number of light oscillations. Theoretical predictions (red lines) using (1) and voltage data are practically indistinguishable, demonstrating that no external interference has disturbed the tests.

3-D ANSYS Maxwell software as $l' = 404.11$ mm. The voltage $V(t)$ applied to the Kerr cell electrodes was measured using a North Star voltage probe type PVM 6 [11], mounted in a way different from that used in [5], a technique adopted to simplify data interpretation and improve the precision of the measurement (see the Appendix). The voltage probe used in the tests has an accuracy guaranteed by the manufacturer of less than 1.5% and the authors used a similar probe kept as a reference to check the calibration, before performing experiments with the new Kerr arrangement.

III. RESULTS

In each test, a reproducible train of pulsed electric fields with a maximum peak exceeding 100 kV/cm was applied between the Kerr cell electrodes, while from test to test the water temperature was varied between 292 K (19 °C) and 318 K (45 °C). Due to presently not well-understood phenomena (accumulation of air bubbles, water turbulence, etc.), higher temperature shots do not provide reliable data. Typical experimental results are shown in Fig. 3.

The technique used to analyze the results was presented previously [5]. Briefly, B is calculated only at certain points, i.e., voltage (i.e., electric field) peaks, where the precision is the highest. The fact that in Fig. 3 the trace provided by formula is practically indistinguishable from the real light trace is not related to any precision, as this information is not used in the measurement of the Kerr constant. It only serves to

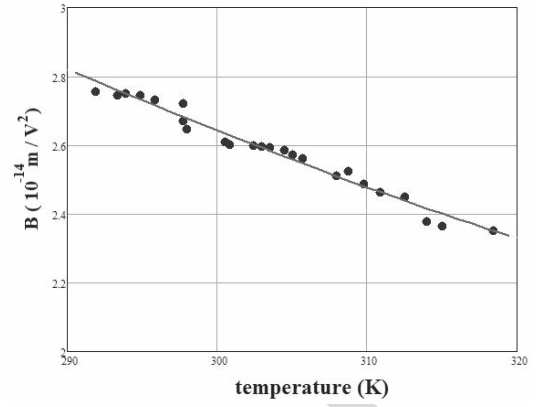

Fig. 4. Temperature dependence of the Kerr constant for water at 658 nm. Full circles are experimental data while the line represents a temperature polynomial fit (see text).

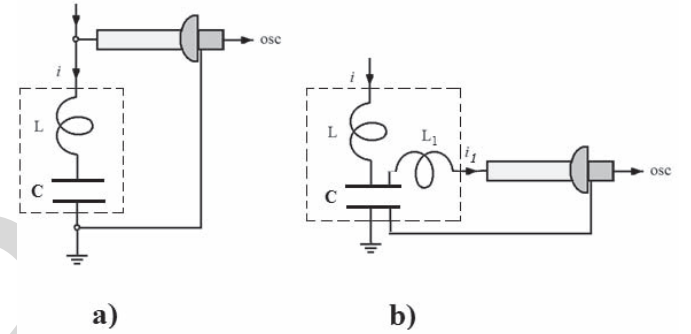

Fig. 5. Alternative ways of mounting the voltage sensor to measure the voltage impulse applied to a Kerr cell, represented by the dotted rectangle.

demonstrate that there is no external interference disturbing the actual test. The measurement of the Kerr constant is, however, affected by the following errors [5]:

$$\frac{\Delta B}{B} = \pm \frac{\Delta \delta(t)}{\delta(t)} \pm 2 \frac{\Delta d}{d} \pm \frac{\Delta l'}{l'} \pm 2 \frac{\Delta V(t)}{V(t)}. \quad (3)$$

The detailed analysis [5] is perfectly applicable to the present work and shows the total error for each right-hand side term is, respectively, $\pm 2\%$, $\pm 3\%$, $\pm 1\%$, and $\pm 3\%$, resulting in a very conservatively estimated total error of less than $\pm 10\%$. It is important to note that the statistical scatter for many identical experiments is always much less than this.

As expected, the Kerr constant B is affected by the temperature T and, for the data points in Fig. 4, the best polynomial interpolation (presented in a form similar to that used in previous work [6]–[8]) was found as

$$\frac{B(T, \lambda_{\text{ref}})}{B(T_{\text{ref}}, \lambda_{\text{ref}})} = \sum_{k=0}^3 \frac{A_k}{T^k} \quad (4)$$

where the result is normalized to the Kerr constant $B(T_{\text{ref}}, \lambda_{\text{ref}}) = 2.746 \cdot 10^{-14}$ (m/V²) at an arbitrarily chosen reference temperature of $T_{\text{ref}} = 294$ K, with $\lambda_{\text{ref}} = 658$ nm. The four polynomial constants are

$$A_0 = 12.59900; \quad A_1 = -1.16036 \cdot 10^4 \text{ K} \\ A_2 = 3.65080 \cdot 10^6 \text{ K}^2 \quad A_3 = -3.65043 \cdot 10^8 \text{ K}^3.$$

The nonlinear least-squares fit mathematical procedure used in obtaining the four constants provided a correlation coefficient of 0.987 with a confidence level of 0.99. The error in calculating B using (4) is conservatively estimated as $\pm 10\%$.

IV. CONCLUSION

This paper has accurately defined the Kerr constant for water for a range of temperatures between 19 °C and 45 °C. When Kerr sensors use laser wavelengths λ slightly different from that of this paper, the appropriate Kerr constant can be estimated with $\pm 10\%$ error from

$$B(T, \lambda) \approx B(T_{\text{ref}}, \lambda_{\text{ref}}) \frac{\lambda_{\text{ref}}}{\lambda} \sum_{k=0}^3 \frac{A_k}{T^k}. \quad (5)$$

The results obtained represent an important step in the development of a reliable and accurate pulsed electric field measurement technique. It is of particular value for PEF treatment systems and in general for water-filled HV pulsed power components such as transmission lines, capacitors, and spark gaps.

APPENDIX

Fig. 5 presents two ways in which a voltage sensor can be mounted to measure the voltage impulse applied across the Kerr cell capacitance C .

- 1) In this case, a current i having a high time rate-of-change di/dt flows through the cell and, therefore, the voltage across C is different from that measured by the voltage sensor, which includes the supplementary inductive term $L \cdot di/dt$. To obtain the required result, a correction must be made, as indicated in [5].
- 2) In this case, the connection between the sensor and the Kerr cell has a low value of self-inductance L_1 and, due to the high-impedance of the sensor, the time rate-of-change of the current i_1 is extremely small and the inductive voltage term $L_1 \cdot di_1/dt$ is consequently negligible. In this case, the sensor measures accurately the voltage across C and no corrections are required.

Another voltage measurement issue is related to the inductive effects introduced by the self-inductance of the connection to ground. To minimize as much as possible the parasitic inductance between the ground and the lower plate of the Kerr cell capacitor, a wide (300 mm) and relatively short (less than 0.8 m) copper sheet was used. The laboratory ground is a large area (many square meters) of thin copper layer covered by wooden plates for protection and connected to a purpose-made low-resistance ground situated in the immediate vicinity of the pulsed power laboratory where experiments took place.

REFERENCES

- [1] ANSYS Maxwell, accessed on Sep. 2015. [Online]. Available: <http://www.ansys.com/Products/Simulation+Technology/Electronics/Electromechanical/ANSYS+Maxwell>
- [2] Quickfield, accessed Sep. 2015. [Online]. Available: <http://www.quickfield.com/>
- [3] CST EM Studio, (accessed Sep. 2015). [Online]. Available: <https://www.cst.com/Products/CSTEMS>

- [4] G. Gaborit *et al.*, "Single shot and vectorial characterization of intense electric field in various environments with pigtailed electrooptic probe," *IEEE Trans. Plasma Sci.*, vol. 42, no. 5, pp. 1265–1273, May 2014.
- [5] B. M. Novac *et al.*, "Determination of the Kerr constant of water at 658 nm for pulsed intense electric fields," *IEEE Trans. Plasma Sci.*, vol. 40, no. 10, pp. 2480–2490, Oct. 2012.
- [6] Y.-J. Chen and W. H. Orttung, "Temperature dependence of the Kerr constant of water," *J. Phys. Chem.*, vol. 76, no. 2, pp. 216–221, 1972.
- [7] R. K. Khanna, E. Dempsey, and G. P. Jones, "Kerr constant of water from 280 to 350 K at 632.8 nm," *Chem. Phys. Lett.*, vol. 53, no. 3, pp. 542–544, 1978.
- [8] R. E. Hebner, Jr., R. J. Sojka, and E. C. Cassidy, "Kerr coefficients of nitrobenzene and water," Nat. Bureau Standards, Boulder, CO, USA, Final Rep. AFWL-TR-76-117, 1976.
- [9] B. M. Novac *et al.*, "Demonstration of a novel pulsed electric field technique generating neither conduction currents nor Joule effects," *IEEE Trans. Plasma Sci.*, vol. 42, no. 1, pp. 216–228, Jan. 2014.
- [10] L3 Applied Technologies, accessed on Sep. 2015. [Online]. Available: http://www2.1-3com.com/ati/pdfs/PA80_PA100.pdf
- [11] North Star High Voltage, accessed on Sep. 2015. [Online]. Available: <http://www.highvoltageprobes.com>

Bucur M. Novac (M'06–SM'08) received the M.Sc. and Ph.D. degrees from the University of Bucharest, Romania, in 1977 and 1989, respectively.



He joined Loughborough University, Leicestershire, U.K., in 1998, where he is currently a Professor of Pulsed Power. He is a Chartered Engineer with the Institution of Engineering and Technology (IET), Stevenage, U.K. He has co-authored two books on explosive pulsed power and has authored over 200 refereed papers and conference contributions. His current research interests include compact and repetitive high-power systems, explosively and electromagnetically driven magnetic flux compression generators and their applications, electromagnetic launchers, ultrafast magneto and electro-optic sensors, and 2-D modeling of pulsed-power systems.

Dr. Novac is a Voting Member of the Pulsed Power Science and Technology Committee in the IEEE Nuclear and Plasma Science Society. He is also a member of the International Steering Committees for the MEGAGAUSS Conferences and the Euro-Asian Pulsed Power Conferences. He is also a member of the Organizing Committee of the IEEE International Power Modulator and High Voltage Conference and a Co-Chairman of the U.K. Pulsed Power Symposium. He is a fellow of IET.

Robert Ruscassié received the M.Sc. degree in electrical engineering and the Ph.D. degree from Université Montpellier II, Montpellier, France, in 2001 and 2005, respectively.



He is currently a Lecturer and Researcher with the Sciences de l'Ingénieur Appliquées à la Mécanique et au Génie Electrique Laboratory, Université de Pau et des Pays de l'Adour, Pau, France. His current research interests include energy conversion and associated metrology for pulsed power applications.

Meng Wang (S'13) was born in China. She received the B.Sc. degree in electronics science and technology from the Huazhong University of Science and Technology, Wuhan, China, in 2011, and the M.Sc. degree in power systems engineering from University College London, London, U.K., in 2012. She is currently pursuing the Ph.D. degree with the Pulsed Power Group, Loughborough University, Leicestershire, U.K. Her Ph.D. project is focused on the development of a 10 GW pulsed power generator and the techniques required to modulate its output.

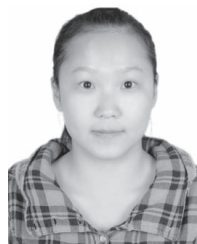

Her current research interests include compact and repetitive pulsed power, ultrahigh speed sensors, and modeling and analysis of 3-D electromagnetic systems.



Antoine Silvestre De Ferron was born in Tarbes, France, in 1977. He received the Ph.D. degree in electrical engineering from the Université de Pau et des Pays de l'Adour (UPPA), Pau, France, in 2006.

He was a Researcher with the Atomic Energy Commission, Le Barp, France, from 2006 to 2008, a French-government-funded technological research organization. He is currently an Engineer with the Laboratoire Sciences de l'Ingénieur Appliquées à la Mécanique et au Génie Electrique Laboratory, UPPA. His current research interests include high

pulsed power generation for military and civil applications, and combined high-voltage transient probes.



Laurent Pécastaing was born in Bayonne, France, in 1974. He received the Ph.D. degree and the Research Directorship Habilitation degree in electrical engineering from the Université de Pau et des Pays de l'Adour, Pau, France, in 2001 and 2010, respectively.

He is currently a Lecturer with the Laboratoire Sciences de l'Ingénieur Appliquées à la Mécanique et au Génie Electrique Laboratory, Université de Pau et des Pays de l'Adour. His current research interests include high-power microwave sources, compact

pulsed power devices, pulse-forming lines or Marx generators, and ultrafast transient probes.



Ivor R. Smith (M'05–SM'11) received the B.Sc., D.Sc., and Ph.D. degrees from the University of Bristol, Bristol, U.K.

He then became a Lecturer with the University of Birmingham, Birmingham, U.K., where he was promoted to Senior Lecturer and Reader and continued his research contribution. He was a Professor of Electrical Power Engineering, and served as the Head of Department, the Dean of Engineering, and a Pro-Vice Chancellor with Loughborough University, Leicestershire, U.K. He received the indentured student apprenticeship with Witton Works, General Electric, Fairfield, CT, USA. He has been active in research in many aspects of the production, conditioning, and utilization of large pulses of electrical energy, for a span of 25 years. His work has brought in very substantial funding from a variety of sources. He is currently a Chartered Engineer with The Institution of Engineering and Technology, Stevenage, U.K.

Dr. Smith is a fellow of the Royal Academy of Engineering, London, U.K.



Jiahui Yin received the M.E. degree in nuclear technology and applications from the Northwest Institute of Nuclear Technology, Xi'an, China. He is currently pursuing the Ph.D. degree with the State Key Laboratory of Electrical Insulation and Power Equipment, Xi'an Jiaotong University, Xi'an.

He was with the Northwest Institute of Nuclear Technology in 2000. His current research interests include MV switches and trigger generators.

IEEE PREPRINT