

## EXHAUSTIVE SEARCH: DOES IT HAVE A ROLE IN EXPLORATIVE DESIGN?

Jonathan Wright, Elli Nikolaidou, Christina J. Hopfe

School of Civil and Building Engineering, Loughborough University, Loughborough, UK

### ABSTRACT

Building performance simulation (BPS) is used routinely in design practice to evaluate the performance of candidate design solutions. However, two sources of uncertainty exist in the design process: in the selection of an optimum design solution; and in the predicted performance of the building (say, due to uncertain boundary conditions). These uncertainties can be evaluated and reduced through the use of an “explorative design” process, in which uncertainty quantification, multi-objective optimization, and sensitivity analysis are combined to provide information on the choice of robust and optimal design solutions. This paper investigates the use of an exhaustive search method to sample all combinations of design solutions and uncertain boundary conditions. The number of samples, and therefore the range of designs considered, are limited by the computation time of BPS. However, this paper concludes that design standards can be used to identify a viable range of design options, and that an exhaustive search applied to a limited design space provided enough information to identify and select robust design solutions. The paper also demonstrates the use of a new approach to identifying robust solutions that are guaranteed to remain optimal, regardless of the prevailing uncertainty in the boundary conditions.

### INTRODUCTION

The aim of the building design process is to create a building that responds to the client’s needs while complying with building regulations. According to Laseau (2001), problem-solving in architectural design commonly involves five steps: 1) definition of the design problem; 2) generation of design alternatives; 3) evaluation; 4) selection; and 5) communication. To generate and evaluate candidate design solutions, the designer has to create several combinations of values for the available variables and assess their performance with respect to the objectives and constraints of the design problem. Based on the performed evaluation, the designer (decision-maker) can subsequently select the best-performing option, this being the combination of

values that provides the most satisfactory performance.

However, under contemporary design practice, the selected design and its performance is subject to two forms of uncertainty:

1. for any building, a high number of alternative design solutions exist; as such, there is uncertainty in the extent to which a design having an optimum performance has been selected; the difference between the performance of the selected design, and a truly optimum performance results in a “**design gap**”;
2. for any design solution, there is uncertainty in the quality of construction (including thermal properties of materials), and behaviour of the boundary conditions (weather and occupant driven loads), this uncertainty manifesting itself as a “**performance gap**”.

The uncertainty in identifying and selecting an optimum design solution is a form of epistemic (systematic) uncertainty, whereas, the uncertainty in the quality of construction and behaviour of the boundary conditions are forms of aleatoric (random) uncertainty. The epistemic uncertainty has an impact on the definition and selection of design alternatives, whereas the aleatoric uncertainty affects the certainty in the performance prediction of any design.

“**Explorative design**” is an emerging paradigm in which numerical techniques are used to explore the uncertain design space in a way that increases the understanding of the relationship between the design solutions and probable performance of the building, this understanding aiding decision-making and the selection of an optimized design solution. The tools used in exploratory design are:

1. **sensitivity analysis (SA)**: this providing information on the sensitivity of the design objectives and constraints to changes in the value of the design (epistemic) variables;
2. **multi-objective optimization (MOO)**: this providing information on the

relationship between the design solutions (the epistemic variables), and the trade-off between conflicting design objectives; since all solutions identified by the MOO are known to have optimal performance, MOO also removes the uncertainty associated with selecting a design solution and it eliminates the “design gap”;

3. **uncertainty analysis (UA):** for all design solutions, UA provides information on the probable range of building performance that results from the uncertainty in the construction and boundary conditions (the aleatoric variables); SA and MOO are therefore applied to probabilistic, rather than deterministic, design objectives.

This paper considers the use of MOO and UA in building design optimization. In particular, the paper investigates the use of an exhaustive search method in generating all possible combinations of epistemic and aleatoric variables. The resulting set of design solutions and uncertain performance conditions, are post-processed to identify an optimal set of solutions that minimise the value of the design objectives regardless of the (aleatoric) uncertainty in the building performance prediction. The addition of SA to the process and consideration of the extra information that this can generate, will form part of future research.

The approach is demonstrated in this paper for its use in the simultaneous design optimization of the form of wall construction, simple window and shading geometries, and the heating system control setpoints and operating period. The performance of each candidate design solution is associated with uncertain weather conditions and occupant driven internal loads. Although the parametric design example presented here relates to scheme and detailed design stages, the approach can be applied to earlier architectural design stages, provided that suitable “performance metrics” can be defined by the architect.

### **Uncertainty Analysis and Multi-objective Optimization**

In the majority of existing research, the techniques of UA and MOO have been treated as separate design processes. For instance, Hopfe et al (2013), describe an approach to multi-criterion decision-making that incorporates uncertain building performance, but which does not include optimization in the search for an optimum solution. Similarly, the majority of existing research into MOO is based on the use of Evolutionary Algorithms (EA), but without consideration of the uncertainty in the building performance (Evins, 2013). However, Van Gelder et al (2013), and Nix et al (2015), describe approaches for probabilistic MOO. While Nix et al (2013), use an EA for the

optimization, Van Gelder et al (2014), advocate the use of a “full factorial” exhaustive search, but one in which a sensitivity analysis is used to reduce the design space before performing the optimization. Both have probabilistic objective functions that attempt to minimise both the mean value and possible spread of the objective function values. Other methods for evolutionary MOO with uncertainty are also described by Goh and Tan (2009).

### **Exhaustive Search – Potential and Limitations**

This paper is focused on investigating the use of an exhaustive search in the MOO of buildings with uncertain performance objectives. An exhaustive search is one in which all possible solutions are evaluated. As such, there is no “search direction” or formal identification of the optimum solutions, with the optimum solutions being identified through the post-processing of all solutions.

An exhaustive search offers several **advantages** over other search methods. First, since all possible design solutions and uncertain performance conditions are evaluated, it provides the maximum possible information for use in decision-making. This is particularly important for an *a posteriori* or *progressive* decision-making approach where the design criteria and focus may change within the decision-making process. Such flexibility is limited when a conventional (say EA), optimization method is used, as only a sub-set of all possible solutions are available, with the result that a change in design focus (criteria), is likely to require a re-run of the optimization process. A caveat to the flexibility provided by an exhaustive search is that all criteria likely to be used in the decision-making must be evaluated during the exhaustive search. In contrast, a conventional MOO only identifies a sub-set of the total number of solutions, these being defined by the *a priori* definition of the optimization objectives. As such, it is not possible to explore changes to the definition of optimality (say by say changing the number or form of the objectives); any change in the problem definition requiring a re-run of the optimization.

Second, the optimization process is not limited by the number of objective functions or constraints. Many of the MOO methods used in current building research seek the trade-off between only two objectives since several of the algorithms are ineffective in solving “many objective” optimization problems. An exhaustive search is immune to the computation difficulties of finding optima in a many-objective search space, since this is an easily implemented post-processing problem. In comparison to other optimization methods, exhaustive search is also one of the easiest to implement, and is fully scalable in terms of its parallel implementation (in contrast, the extent to

which an EA can be implemented using a parallel execution, tends to be limited by the population size).

Third, the results can be post-processed for the first and second order sensitivities using a “one-at-a-time” approach.

The **limitation** of an exhaustive search is readily apparent in that the number of solutions to be evaluated increases as a product of the number of values for each variable (both epistemic and aleatoric variables in this case). The longest computation time in building optimization results from the building performance simulation (BPS). This has resulted in the use of fast executing surrogate models of the building performance (among others; Van Gelder et al, 2013; Nix et al, 2015; Brownlee and Wright, 2015). However, the accuracy of these models introduces further uncertainty to the optimization process, and so in this paper, we consider an approach in which all design solutions are evaluated using the full BPS.

The use of a full BPS limits the number of solution evaluations that can be performed in a practicable time. The practicable time and associated number of simulations are dependent on the complexity of the building being modelled (for instance, the number of heat transfer surfaces), and the computing power available. In this paper, an arbitrary limit of 10,000 simulations is adopted, this however being partly informed by previous research that set a practicable limit for a deterministic optimization of 5,000 simulations (Brownlee and Wright, 2015); the extra simulations have been allowed due to the increased problem and decision-making complexity introduced through the aleatoric variables.

Limiting the number of solutions in turn limits the number of variables and value options for each variable. For example, if the number of value options ( $N_{val}$ ), is set to be the same for all variables, the relationship between the nearest number of variables ( $N_{var}$ ) and the number of solutions ( $N_{sol}$ ), is given by:

$$N_{var} = \left\lfloor \frac{\log(N_{sol})}{\log(N_{val})} \right\rfloor \quad (1)$$

Given a maximum of 10,000 solutions and say, 3 value options for each variable, equation (1) gives 8 variables (and a reduced search space of 6561 solutions). If say, two of the variables are uncertain (aleatoric) boundary conditions, then the design search space is reduced to just 729 solutions ( $= 6561/(3 \times 3)$ ). This example raises two questions: first, given the limited search space, can any useful information be gained from the use of an exhaustive search? Second, given the limited options for each variable, can they be assigned meaningfully values?

## Research Aims

In the context of the use of an exhaustive search with a limited number of solution evaluations, this paper aims to investigate:

1. an approach to the selection of a limited number of variables, and value options for each variable;
2. the extent to which any useful information might be obtained from the limited number of design solutions;
3. a new approach to identifying robust Pareto optimal solutions (“robust” here being solutions whose optimality are immune to the aleatoric uncertainty).

## METHODOLOGY

There are three core elements to the research methodology applied in this paper: the identification of a case-study building form; the development and discussion of the design optimization problem; and the development of a new approach to identifying robust design solutions.

### Case Study Building and Performance Simulation

This study is based on the simple single-zone office building that has been derived from a Building Energy Simulation Test (BESTEST), building (Judkoff and Neymark 1995). Figure 1, illustrates that the building has no doors and two large south-facing windows that are shaded by a large overhang.

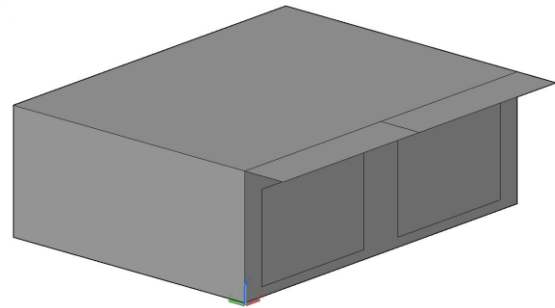

Figure 1, Case-study Building

The performance of the building is simulated using the EnergyPlus simulation engine. The simulation includes zone heating, but not mechanical cooling. Ventilation is provided at a constant rate of 0.04 m<sup>3</sup>/s, this being equivalent to 10 l/s per occupant at full occupancy (4 persons); ventilation and heating are available all year from the specified system start-time (this being a design variable), until the end of occupancy. Electrical equipment loads are set at 110W/person and lighting at 8W/m<sup>2</sup>. Both the electrical and lighting loads are varied in direct proportion to the number of occupants; the demand for artificial lighting is further controlled by two light sensors located in the middle of the space and

having an illuminance setpoint of 500lux. Occupancy is from 08:00 to 17:00.

### Problem Definition: Design Objectives

The study in this paper is based on 3 objective functions: annual energy use; hours of under-heating; and hours of over-heating. All three criteria are to be minimised. The annual energy use is a function of heating energy use, and the energy used in artificial lighting. Hours of under and over-heating are based on a comfort limit of  $\pm 0.5$  PMV (Predicted Mean Vote), under-heating being a count of occupied hours for which the PMV is below  $-0.5$  and over-heating a count of hours above  $+0.5$  PMV.  $\pm 0.5$  PMV is a common target for occupant thermal comfort (ASHRAE, 2013).

### Problem Definition: Epistemic Design Variables

The exhaustive search demands that the number of variables and value options are limited. 8 variables have been identified in this paper due to their potential influence on the design objectives: the type of wall construction, type of roof construction, infiltration rate, glazing type, window-to-wall ratio (WWR), depth of shading overhang, heating setpoint, and heating start time (Table 1).

The number of value options for each variable is limited by real-world consideration of the design parameter. In particular, the options for the type of wall and roof construction have been developed to be compliant with two standards: the Approved Document L2A of the UK Building Regulations (UK Government, 2013) and the higher standard of thermal insulation (U-value), described by the Passivhaus Standard (Mead and Brylewski 2010). Two options have been selected to be compliant with each standard, a thermally lightweight construction (LW), and a thermally heavyweight construction (HW). The Architects' Data book by Neufert et al (2012), has been used as a guide for creating the Part L (PL) constructions, while the Passivhaus (PH), constructions have been developed according to a catalogue of ecologically rated constructions (Einheiten, 2009) and the Passivhaus guide of the Association for Environment Conscious Building (AECB, 2007). The purpose of selecting two constructions that have the same U-value but a different thermal mass, is to test the impact of thermal mass on optimum energy use and over-heating risk.

Building Regulations Part L and Passivhaus Standard have also been used as a guide for defining the values for the infiltration rate as well as the type of glazing units, these representing real-world products as given in the Spon's Architect's and Builder's price book (AECOM, 2015).

Table 1 Variables and Assigned Values

| Type      | Variable           | Number of options | Values                                       |
|-----------|--------------------|-------------------|--|
| Epistemic | Wall construction  | 4                 | 1. HW-PH<br>2. HW-PL<br>3. LW-PH<br>4. LW-PH |
|           | Roof construction  | 4                 | 1. HW-PH<br>2. HW-PL<br>3. LW-PH<br>4. LW-PH |
|           | Infiltration rate  | 2                 | 1. PH (0.05 ACH)<br>2. PL (0.50 ACH)         |
|           | Glazing type       | 2                 | 1. PH<br>2. PL                               |
|           | WWR                | 2                 | 1. 55.6%<br>2. 27.8%                         |
|           | Overhang           | 2                 | 1. 1.0m<br>2. 0.3m                           |
|           | Heating setpoint   | 3                 | 1. 19°C<br>2. 21°C<br>3. 23°C                |
|           | Start time         | 3                 | 1. 5:00<br>2. 6:00<br>3. 7:00                |
| Aleatory  | Occupancy schedule | 2                 | 1. 25% (1 person)<br>2. 100% (4 persons)     |
|           | Weather file       | 2                 | 1. CIBSE<br>2. IWEC                          |

Two WWRs of 55.6% and 27.8%, have been selected to indicate the broad choice of glazed area; the larger area is the default BESTEST case, with the smaller area being half the default case. The smaller area is achieved by halving the height of both windows (the width of the windows is fixed, and the window upper edge remains fixed in position). The Spon's (AECOM, 2015), price book has also been used to help identify the choice of overhang depth of 0.3m; the alternative depth is taken to be the default BESTEST case of 1.0m.

The discrete values for the heating setpoint have been defined with respect to the CIBSE Guide A (CIBSE, 2006), according to which the winter operative temperature should vary between 21°C and 23°C for an office space. A cooler scenario of 19°C is also considered.

### **Problem Definition: Aleatoric Boundary Variables**

Aleatoric uncertainty is included through two boundary conditions: the source of weather data; and occupant density, with the heat gains from equipment and artificial lighting also being varied in proportion to the occupant density. A uniform probability of selection is applied to both boundary conditions.

Even though they may have been formed for the same purpose (say predicting annual energy use), different sources of weather data are known to have an effect on the results of building design optimization (Pernigotto et al, 2015). In this paper, two alternative sources of weather data have been used: the test reference year (TRY), formulated by the CIBSE (CIBSE, London, UK); and the IWEC TRY available through the EnergyPlus simulation distribution site.

The estimation of occupant profiles and more particularly, the associated equipment loads, is non-trivial (Page et al, 2008; Menezes et al, 2014); in this paper, two extremes of occupant density and equipment loads are taken, 100% occupancy (4 people), and 25% occupancy (the lowest limit of 1 person).

### **Identification of Robust Solutions**

This paper is focused on examining the use of an exhaustive search in the identification of Pareto optimum solutions for the trade-off between three design objectives, the value of the objectives being uncertain for a given design solution.

The robustness of a design solution having uncertain performance can be defined in several ways (Rysanek and Choudhary, 2013), but in MOO, a common approach is to form optimization objectives from the mean or median performance values together with a value of performance spread (Van Gelder and Roels, 2014; Nix et al, 2015). For instance, the optimization objective could be formed to be  $u + \alpha \times \sigma$ , where  $u$  is the mean objective function value and  $\sigma$  its standard deviation. If  $\alpha$  is taken as 1.0, this results in objective function values for which there is only a ~16% probability of the objective function value being worse (a worse value being a higher value in this case). This approach is useful when the uncertainty in the objective function value has been evaluated using a statistical sample of the uncertain performance. However, since an exhaustive search provides all uncertain performance conditions (rather than just a sample of the conditions), it is possible to develop a more deterministic approach to judging the robustness of a design solution.

The new approach developed in this paper is that robustness is not simply defined in terms of the statistical dispersion of the objective function values, but rather that, *regardless of the prevailing (uncertain) boundary conditions, the selected design solution(s) should remain Pareto optimal*. A corollary of this definition is that *for all uncertain conditions, the performance of the building is always optimal* (that is, the objective function values will always lie on the optimum Pareto trade-off between the objectives).

The approach is implemented in a two-stage process:

1. find the Pareto set of solutions for each combination of the uncertain conditions (there being 4 combinations in this paper; Table 2);
2. for each possible design solution, count the number of uncertain combinations for which the solution is Pareto optimal; a count of 0 indicates that regardless of the boundary conditions, the design solution is always sub-optimal; a count equal to the number of combinations of boundary conditions (4 in this paper), indicates that the solution has maximum robustness as it remains optimal regardless of the boundary conditions.

## **RESULT AND ANALYSIS**

The results and analysis presented in this paper are restricted to: an analysis of the impact of the uncertain boundary (aleatoric), conditions on the Pareto optimality; the selection of a robust Pareto set; and to an analysis of the variation in the design solutions throughout the Pareto trade-off set.

### **Performance Uncertainty and the Selection of Pareto Optimal Solutions**

The uncertain performance of a particular design solution is derived in this paper from 2 uncertain boundary conditions: the source of weather data; and the occupant density (and associated equipment heat gains). Each of the uncertain boundary conditions has 2 uniformly weighted choices, giving 4 uncertain performance conditions (Table 2).

*Table 2, Uncertain Boundary Conditions*

| <b>Combination of Uncertain Boundary Condition</b> | <b>Weather Source</b> | <b>Number of Occupants</b> | <b>Number of Pareto Design Solutions</b> |
|--|-----------------------|----------------------------|--|
| (a)  | CIBSE                 | 1                          | 157                                      |
| (b)  | CIBSE                 | 4                          | 259                                      |
| (c)  | IWEC                  | 1                          | 217                                      |
| (d)  | IWEC                  | 4                          | 283                                      |

Table 2 indicates that the number of Pareto optimal solutions for the minimization of all three objective functions, varies with the combination of uncertain boundary conditions, the variation being between 6.8% and 12.3% of the 2304 possible design solutions. It would appear that the IWEC weather file and higher occupant density, result in a larger Pareto set. Although the reasons for this have not yet been investigated, it should be noted that this is not an artifact of the optimization process, as there is no uncertainty in the convergence of an exhaustive search. It is also the case that the number of Pareto solutions is larger than the population sizes used with most EA in solving building optimization problems, and so these algorithms would have to be implemented with a solution archive in order to be able to capture the same number of Pareto optimal solutions.

### Robust Pareto Optimal Solutions

Table 2 indicates that the number of Pareto optimal solutions varies with the uncertain conditions. The robust Pareto set is defined here to be the solutions that appear most frequently in the Pareto sets for all uncertain conditions. In this case, 66 of the 2304 possible design solutions were included in the Pareto set for all uncertain boundary conditions; 1866 of the possible design solutions were dominated (sub-optimal) and excluded from all Pareto sets.

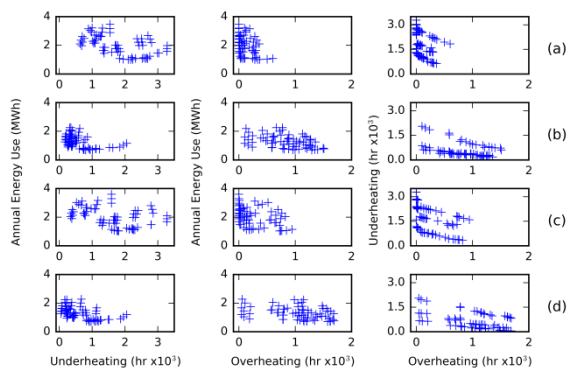

Figure 2, Robust Pareto Optimal Solutions

Figure 2, illustrates the 66 robust Pareto design solutions as scatter plots for pairs of the 3 design objectives and the 4 uncertain performance conditions. Row labels (a) to (d) are for the combination of uncertain boundary conditions given in Table 2. A comparison of the solutions in rows (a) and (b), or (c) and (d), indicates that (as would be expected), an increase in occupancy (and associated equipment and lighting heat gains), results in a reduction in (heating) energy use, a reduction in underheating hours, but an increase in overheating hours. A comparison of rows (a) with (c), or (b) with (d), indicates that although the

general trends are the similar, the source of weather data has an impact on the particular distribution of the solutions.

### Solution Trade-off Analysis

Several techniques can be used to illustrate the relationship between the value of each design variable and the optimized trade-off (Brownlee and Wright, 2012). Some techniques, such as the rank-ordering of solutions, only work when two objective functions are considered. Given that this analysis is for three objectives, the analysis presented here is based on a parallel coordinate plot and a new approach (Figure 3), to examining the distribution of variable values within the Pareto set.

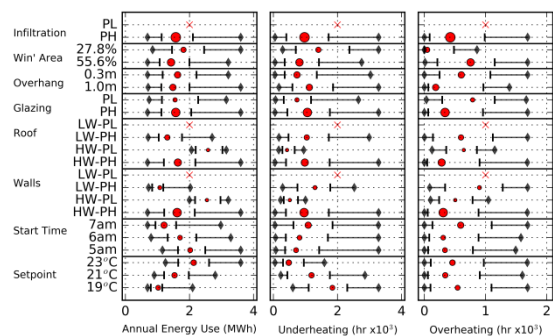

Figure 3, Distribution of Variable Values for the Robust Pareto Optimal Solutions

Figure 3, uses simplified box-plots to illustrate the distribution of design variable values for each objective. The distributions are for all 66 robust Pareto solutions and their associated uncertain performance conditions (4 per design solution). The (red) circles are the median values of the objective functions for all solutions having the particular variable value; the larger the circle, the higher the number of Pareto optimal solutions having the particular value for the variable. A (red) cross at the centre of the range of objective values indicates that none of the Pareto optimal solutions contained this value for the particular variable. For instance, all Pareto solutions for infiltration had the infiltration set to the Passivhaus (PH) standard, with all "Part L" (PL) solutions being sub-optimal. Infiltration is an example of a "distance" variable (Brownlee and Wright, 2012) as a change in its value from "PH" to "PL" will move the whole Pareto front to a position where it is sub-optimal. The impact of such a change on the objective function values can be evaluated through the use of a sensitivity analysis, this being included in future research. The vertical bars in Figure 3 indicate the 25<sup>th</sup> (lower) and 75<sup>th</sup> (upper) quartiles and the diamonds the minimum and maximum values. The figure indicates that the most frequently optimal (largest median circle), construction elements correspond to the heavy-weight Passivhaus

standard (HW-PH); the choice of value for other variables is more evenly distributed, these variables most likely being categorised as “position” variables (Brownlee and Wright, 2012), with a change in value corresponding to a move of the solution along the trade-off. The figure also illustrates some predictable trends; for instance, the higher the heating setpoint temperature, the more energy is used and the lower the number of under-heating hours.

Although Figure 3 is useful in indicating the frequency that a particular variable value appears in the Pareto set (and the extent to which they may be categorised as “distance” or “position” variables), the plot does not show the relationship between variables. Figure 4, uses a parallel coordinate plot to show the relationship between all variable values, and the median objective function values, for all 66 robust Pareto solutions.

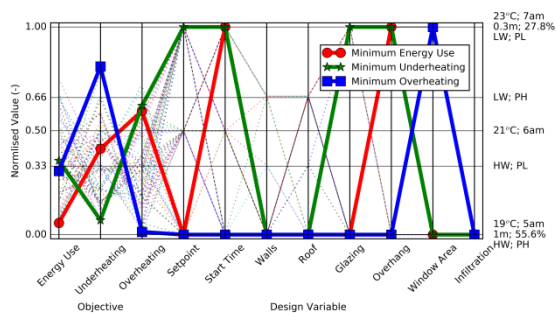

Figure 4, Parallel Coordinate Plot of Robust Pareto Solutions

Three solutions are emphasized; those having the lowest median energy use; lowest median under-heating hours; and lowest median over-heating hours. For clarity, all other solutions have been plotted as faint dotted-lines. An example of the difference in interpretation of Figures 3 and 4 is that in the parallel coordinate plot, the system start-time for minimum under-heating is 7am, just one hour before occupancy. However, this is counter to the conclusion that might be drawn from the independent analysis of the start-time in Figure 3, this suggesting that the underheating hours are minimised for the earlier start-time of 5am. The reason for the difference is that the parallel coordinate plot links the setpoint temperature to the required start-time, the under-heating hours being minimised with a higher setpoint temperature of 23°C (and probable higher-capacity heating system). Several other observations can be drawn from the parallel coordinate plot, not least of which is that regardless of which criteria are minimised, the wall and roof constructions are always selected to be heavy-weight and conforming to the Passivhaus standard (HW; PH).

## DISCUSSION AND CONCLUSIONS

An exhaustive evaluation of all combinations of all possible design solutions and uncertain boundary conditions has the potential to increase the understanding of the relationship between the design solutions and the design objectives, and to provide flexibility in an *a posteriori* decision-making process.

However, the long computation time associated with simulating the performance of a building limits the number of design options that can be evaluated in a practicable time. In this paper, it is suggested that a range of design options for each variable (such as the different types of wall construction), can be informed by the specifications given in one or more design standards. This approach also has the effect that the uncertainty in the validity of the design option is reduced since it is known to conform to at least one standard.

The need to limit the computation time, and therefore the number of design solutions evaluated by the exhaustive search, might restrict the amount of useful information obtainable from the search. However, the results and analysis given in this paper demonstrate that, for the case-study building at least, a significant degree of understanding can be drawn from the limited range of design options. It is therefore concluded that as such, an “exhaustive search” has “a role in explorative design”.

Further research is required to extend the number and type of aleatoric variables, and to investigate the application of the approach to more complex buildings that demand a larger number of design variables (say due to the need to optimize the WWR on each facade). The extension of the search space will most likely demand the use of a surrogate model (particularly those proven to work with mixed-integer construction variables; Brownlee and Wright, 2015).

The paper also demonstrates the use of a new formulation for solution robustness that guarantees that the solution and building performance remain optimal, regardless of the prevailing boundary conditions. Further research is required to investigate its applicability to problems that have a larger number of aleatoric (boundary) conditions.

## ACKNOWLEDGEMENTS

This research is funded by the UK Engineering and Physical Sciences Research Council (EPSRC). The support of the research engineer Eirini Mantesi is also gratefully acknowledged.

## REFERENCES

- AECB, 2007. *CarbonLite Programme - Delivering buildings with excellent energy and CO2 performance*. AECB.
- AECOM, ed., 2015. *Spon's Architect's and Builder's price book*. 140th ed. USA: Taylor & Francis.
- ASHRAE, 2013, Thermal Environmental Conditions for Human Occupancy, ANSI/ASHRAE Standard 55-2010.
- Brownlee, A.E.I. and Wright, J.A., 2012, "Solution Analysis in Multi-Objective Optimization", IBPSA-England Conference on Building Simulation and Optimization, 317-324, Loughborough, UK, September 2012
- Brownlee, A.E.I, and Wright J A, 2015, "Constrained, mixed-integer and multi-objective optimisation of building designs by NSGA-II with fitness approximation", *Applied Soft Computing*, 33, 114-126, doi:10.1016/j.asoc.2015.04.010
- CIBSE, 2006. *Guide A: Environmental design*. CIBSE.
- Einheiten, F., 2009. *Passivhaus-Bauteilkatalog / Details for Passive Houses: Ökologisch bewertete Konstruktionen / A catalogue of ecologically rated constructions*. Germany: Springer.
- Goh, C-K and Tan, K.C., 2009. *Evolutionary Multi-objective Optimization in Uncertain Environments*, Springer, ISBN 978-3-540-95975-5
- Hopfe, C.J., Augenbroe, G.L.M., and Hensen, J.L.M., 2013. Multi-criteria decision making under uncertainty in building performance assessment. *Building and Environment*, 69, 81–90.
- Judkoff, R. and Neymark, J., 1995. *International Energy Agency building energy simulation test (BESTEST) and diagnostic method (No. NREL/TP-472-6231)*. USA.
- Evins, R. 2013, A review of computational optimisation methods applied to sustainable, building design, *Renewable and Sustainable Energy Reviews*, 22, 230-245, doi:10.1016/j.rser.2013.02.004
- Laseau, P., 2001. *Graphic thinking for architects & designers*. 3rd ed. USA: John Wiley & Sons.
- Menezes A C, Cripps A, Buswell R A, Wright J A, Bouchlaghem D, 2014, "Estimating the Energy Consumption and Power Demand of Small Power Equipment in Office Buildings", *Energy and Buildings*, 75, 199-209, DOI: 10.1016/j.enbuild.2014.02.011.
- Mead, K. and Brylewski, R., 2010. *Passivhaus Primer: Introduction - An aid to understanding the key principles of the Passivhaus Standard*. BRE Trust.
- Neufert, E., Neufert, P., and Kister, J., 2012. *Architects' data*. UK: John Wiley & Sons.
- Nix, E. Das, P. Taylor, J. and Davies, M. 2015, Employing a Multi-Objective Robust Optimisation Method for Healthy and Low-Energy Dwelling Design in Delhi, India, ", 14th International Conference of the International Building Performance Simulation Association, Building Simulation 2015, Hyderabad, India, 2093-2100
- Pernigotto, G., Prada, A., Cappelletti, F. and Gasparella, A. 2015, Influence of the Representativeness of reference Weather Data in Multi-Objective Optimization of Building Refurbishment, 14th International Conference of the International Building Performance Simulation Association, Building Simulation 2015, Hyderabad, India, 2857-2864
- Page, J., Robinson, D., Morel, N., and Scartezzini, J.L., 2008. A generalised stochastic model for the simulation of occupant presence. *Energy and Buildings*, 40 (2), 83–98.
- Rysanek, A.M. and Choudhary, R. 2013, Optimum Building Retrofits under Technical and Economic Uncertainty, *Energy and Buildings*, 57, 324-337.
- UK Government, 2013. *The Building Regulations 2010, Approved document L2A: Conservation of fuel and power in new buildings other than dwellings*. UK Government. UK: UK Government.
- Van Gelder, L., Janssen, H., and Roels, S., 2014. Probabilistic design and analysis of building performances: Methodology and application example. *Energy and Buildings*, 79, 202–211.