



Microwave and
Optical Technology Letters

Stitched Transmission Lines for Wearable RF Devices

Journal:	<i>Microwave and Optical Technology Letters</i>
Manuscript ID	MOP-16-1448
Wiley - Manuscript type:	Research Article
Date Submitted by the Author:	10-Oct-2016
Complete List of Authors:	DANIEL, ISAAC; Loughborough University, Electronic and Electrical Engineering Flint, James; Loughborough University, Electronic and Electrical Engineering Seager, Rob; Loughborough University, Electronic and Electrical Engineering
Keywords:	S-Parameters, Stitched Transmission Line, Wearable Devices, Conductive Threads, Stitch Angle

SCHOLARONE™
Manuscripts

View

Stitched Transmission Lines for Wearable RF Devices

Isaac H. Daniel, James A. Flint and Rob Seager

Wolfson School of Mechanical, Electrical and Manufacturing Engineering, Loughborough University, Loughborough,
LE11 3TU

I.H.Daniel@lboro.ac.uk

Abstract

A novel stitched transmission line for wearable devices has been manufactured and tested to measure its scattering parameters from 0.04 to 4GHz. The stitched transmission line which is 150mm long consists of an inner conductor surrounded by a tubular insulating layer. For shielding purpose, the structure is stitched onto a denim material with a conductive thread with the aid of a novel manufacturing technique using a standard hardware. The S-Parameters were investigated with three different stitch angles 85°, 65° and 31° through simulation and experiments, demonstrating that the stitched transmission line can work usefully and consistently from 0.04 to 4GHz.

Keywords— S-Parameters; Stitched Transmission line; Wearable Devices; Conductive Threads; Stitch angle

1. INTRODUCTION

Present day textiles are materials with lots of applications in practically all our daily events. People constantly wear apparels and are continuously surrounded with textiles in virtually all of our environments. The integration of multifunctional values in such a universal material has become a special area of interest in recent years and with rapid advances in civilian and military applications for wearables, it is imperative that in designing such apparels that design requirements such as the operational reliability, controllability, convenience, ergonomics and robustness have to be met in order to meet the desires of the target consumers [1].

Transmission lines essentially consist of two or more parallel conductors which are used to transport RF signals between communication equipment and to connect an RF source to a load. The RF source could be a transmitter while the load could be a receiver. Typical transmission lines include a wire above conducting plane, two wire transmission line, parallel plate or planar line, microstrip line and coaxial cables. Accordingly, a wearable transmission line can be said to be a transmission line that forms part of the apparels that can be worn by humans. Normally this is stitched or embedded onto apparels.

Previous work on using conductive textiles for signal transmission, where conventional transmission lines and circuit boards are replaced with textile fabrics has been conducted in [2]-[3], and the feasibility of using digital embroidery and conducting threads to create transmission lines and potentially antennas has also been investigated in [4]. Similarly, metallic wire knitted fabrics using plating and core spun yarn knitted fabrics which could be tailored to make curtains, tents, window screens and enclosures for electric/electronic devices to shield against EMIs was also considered in [5]-[6], and of recent, the use of micro-cable structured textile for simultaneously harvesting solar and mechanical energy to power wearable devices had been presented in [7]. Further research on textile transmission lines can be seen in [8], [9], [10], and [11].

In this letter a stitched transmission line is proposed for broadband operation. The aim here is to use the idea of a braided coaxial cable to develop a stitched transmission line with measurements taken for frequencies 0.04GHz (limited by measurement set up) to 4GHz. Some of the challenges associated with using textile transmission lines include sourcing of optimal materials to be used, the need for addressable conductors to be insulated from each other, effect of stitch types and densities, and the need to be able to withstand typical textile handling like washing, drying

and ironing. While the advantages of using the stitch transmission line include but are not limited to, sufficient frequency range to support multiple channel, reduced cost, noise and crosstalk.

2. DESIGN AND FABRICATION OF STITCHED TRANSMISSION LINE

Braided coaxial cable can be envisioned as a composite counter wound helical arrangement with a concentric center conductor [12]. This transmission line propagates mainly in the TEM mode, which means that the electric and magnetic fields are both perpendicular to the direction of propagation; the electric field is radial, and the magnetic field is circumferential. However, beyond a certain cut off frequency TE and TM modes can also propagate; this occurs at frequencies where the wavelength in the dielectric is significantly shorter than the circumference of the insulator. The stitched transmission line proposed in this letter also comprises of an inner conductor surrounded by an insulating layer and a stitched shield. The inner conductor and the insulated layer were selected as RG 174, while the stitched shield is made up of conductive threads from Light Stiches®. The designed stitched wearable transmission line was carried out using CST Microwave Studio Suite 2015 as shown in Fig.1. A cross section of the stitched transmission line and a 2-D sketch is as shown in Fig.2.

Figure 1 3-D View of Stitched Wearable Transmission Line Design with CST Studio Suite

Figure 2 Stitched transmission line design: Cross section on top and a top view drawing on the bottom

Fig 3 presents an improved presser foot which was fabricated to aid in stitching the conductive thread around the stripped RG174 and onto the Denim material. The novel presser foot also aided in ensuring that the apparel and stripped RG174 cable were kept in check during the stitch so that they both do not rise and fall with the needle and pucker [13]. The intended slot on the bottom mid-section of the presser foot also helped in making sure that the tubular polyethylene insulator is not ruined during stitching.

Figure 3 Top and bottom view of the novel presser foot

Three different stitch angles $\alpha_{60} = 85^\circ$, $\alpha_{90} = 65^\circ$ and $\alpha_{162} = 31^\circ$ were considered in the design and fabrication of the stitched transmission line.

The stitch angle is given by:

$$\alpha_x = 2 \tan^{-1} \left(\frac{P_x}{2D_S} \right) \quad (1)$$

Where, $D_S = 1.52mm$ is the diameter of the stitched transmission line before stitching, $P_x = P_{60} = 2.76mm$, $P_{90} = 1.94mm$, $P_{162} = 0.83mm$ is the pitch of the stitch with $x = [60,90,162]$ signifying the number of stitches and Δl_x , the stitch length.

Figure 4 Schematic illustration of the stitch angle

Figure 5 Novel presser foot used with Singer Talent sewing machine during stitching

Figure 6 Fabricated stitched transmission line

3. RESULTS AND DISCUSSION

The stitched transmission line is simulated with CST Microwave Studio Suite 2015[®] and measurements were carried out with an Anritsu MS46524A 7GHz Vector Network Analyser (VNA). The stitched wearable transmission line was fed by two Multicomp 13-01-3 TGZ RG174U RF Coaxial, BNC Straight Plug 50Ω.

A. DC resistance of stitched shield

We propose that current flow in the shield of the stitched transmission line follows a zig-zag trace in a porpoise manner. However, cross overs can be achieved at different stitch points within the shield. To determine the DC resistance of the shield per unit length, an equivalent model of the shield was proposed as shown in Fig.7, 8, 9 and 10 for $N = 1, 2, 3 \dots M$, with N representing the total number of stitches and an equation was derived for computing the DC resistance of the shield for any number of stitches.

For stitch angles of $85^\circ, 65^\circ$ and 31° , $R^1 = 0.5, 0.4$ & 0.25Ω respectively, while $R = 0.1\Omega$.

Figure 7 Equivalent electrical model of the stitched transmission line ($N = 1$)

Figure 8 Equivalent electrical model of the stitched transmission line ($N = 2$)

Figure 9 Equivalent electrical model of the stitched transmission line ($N = 3$)

Figure 10 Equivalent electrical model of the stitched transmission line ($N = M$)

For $N = 1$

$$R_1 = 2R + \frac{R^1}{2} \quad (2)$$

For $N = 2$

$$R_1 = 3R + R^1 \quad (3)$$

For $N = 3$

$$R_1 = 4R + \frac{3}{2}R^1 \quad (4)$$

For $N = M$

$$R_M = [(M + 1)R] + \frac{M}{2}R^1 \quad (5)$$

The measured and computed DC resistance of the stitch transmission line for stitch angles of $85^\circ, 65^\circ$ and 31° are presented in Table I.

TABLE I DC RESISTANCE OF SHIELD

B. Transmission Characteristics with Three Stitch Angles

The measured and simulated results for the scattering parameters of the stitched transmission lines are presented as in Fig. 11, 12 & 13 within a frequency range of 0.04 – 4 GHz, for stitch angles of 85°, 65° and 31°, with a straight length of 150mm. Small rifts between the simulated and measured results were observed, which could be attributed to the technique the sparse stitched shield of the fabricated transmission line was built; however a good agreement is generally maintained. The reflection coefficient S_{11} for stitch angle 85° are below $-3dB$ in the entire operation band for simulation and $-10dB$ for measurement in most of the operation band, while the transmission coefficients S_{21} are better than $-4.3dB$ for frequencies up to 2.5GHz for simulation and $-8dB$ for measurement. Equally the measured reflection coefficient S_{11} for stitch angle 65° are below $-2.8dB$ for simulation and $-10dB$ for measurement in most of the operation band, and the transmission coefficients S_{21} are better than $-3.3dB$ for frequencies up to 2.16GHz for simulation and $-10dB$ for measurement. Finally, measured reflection coefficient S_{11} for stitch angle 31° are below $-5dB$ for frequencies up to 2.55GHz for CST and $-10dB$ for VNA in most of the operation band, and the transmission coefficients S_{21} are better than $-3dB$ for frequencies up to 2.5GHz for CST and $-15dB$ for VNA. These results demonstrates that the stitched transmission line can work usefully and consistently within the specified frequency range of 0.04 to 4GHz. However, from the measurement results, resistive losses were observed for frequencies $<1GHz$ with mismatch and radiation losses as the frequency increases. Some ripples were also observed at higher frequencies, which are mainly as a result of multiple reflections along the transmission line. The simulation results indicates less DC losses compared to the measurement results, with mismatch and radiation losses with increase in frequency along the line.

Figure 11 Simulated and measured S-Parameters of stitched transmission line with pitch angle at 85°

Figure 12 Simulated and measured S-Parameters of stitched transmission line with pitch angle at 65°

Figure 13 Simulated and measured S-Parameters of stitched transmission line with stitch angle at 31°

4. CONCLUSION

For the first time the feasibility of using the idea of a coaxial cable to design a stitched transmission line has been introduced. This idea unlocks a range of possible transmission line designs that could fit prospective target applications.

Three different designs were carried out with three different stitch angles of 85°, 65° and 31°, with the aid of a novel manufacturing technique using a standard hardware, the presser foot, and high frequency network analyzer measurements were achieved for frequencies up to 4GHz. The DC resistance of the stitched transmission line with three different stitch angles 85°, 65° and 31° corresponding to the number of stitches 60, 90 and 162 were computed and a mathematical relationship was derived for computing the DC resistance of the stitch transmission line for any given number of stitches. The extracted S-parameters indicated an increase loss with increased number of stitch angle and frequency. These losses are mainly influenced by the DC resistance of the conductive threads at frequencies $<1GHz$. While the DC losses were seen to increase with a decrease in stitch angle which also corresponds to an increase in number of stitches, the radiation loss tends to decrease with a decrease in stitch angle resulting to an increase in number of stitches.

1
2
3
4
5
6
7
8
9
10
11
12
13
14
15
16
17
18
19
20
21
22
23
24
25
26
27
28
29
30
31
32
33
34
35
36
37
38
39
40
41
42
43
44
45
46
47
48
49
50
51
52
53
54
55
56
57
58
59
60

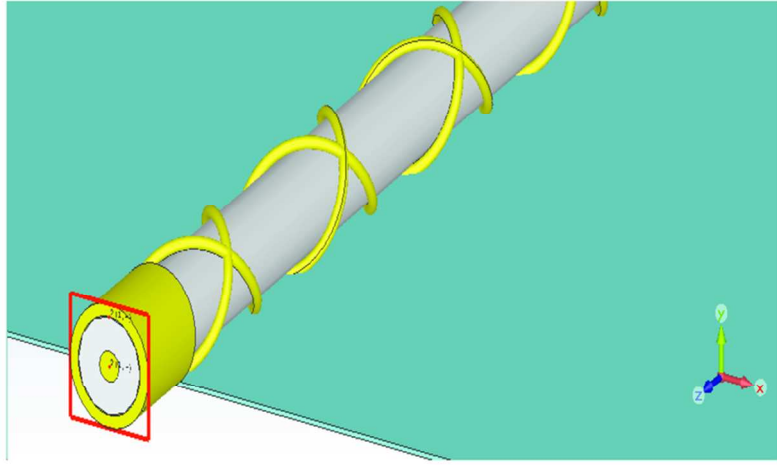

Figure 1 3-D View of Stitched Wearable Transmission Line Design with CST Studio Suite
The designed stitched wearable
86x46mm (300 x 300 DPI)

1
2
3
4
5
6
7
8
9
10
11
12
13
14
15
16
17
18
19
20
21
22
23
24
25
26
27
28
29
30
31
32
33
34
35
36
37
38
39
40
41
42
43
44
45
46
47
48
49
50
51
52
53
54
55
56
57
58
59
60

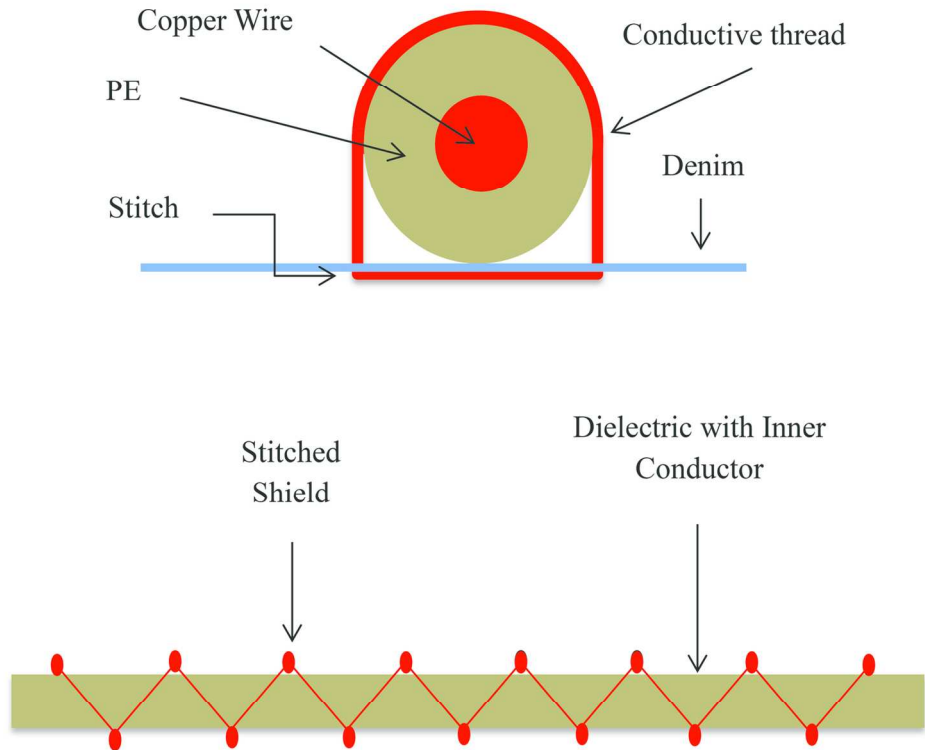

Figure 2 Stitched transmission line design: Cross section on top and a top view drawing on the bottom
The designed stitched wearable
143x146mm (300 x 300 DPI)

1
2
3
4
5
6
7
8
9
10
11
12
13
14
15
16
17
18
19
20
21
22
23
24
25
26
27
28
29
30
31
32
33
34
35
36
37
38
39
40
41
42
43
44
45
46
47
48
49
50
51
52
53
54
55
56
57
58
59
60

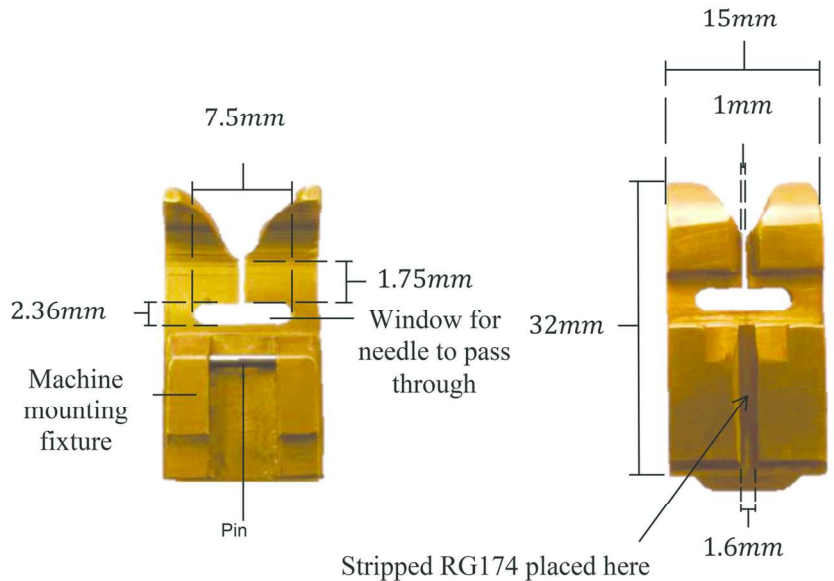

Figure 3 Top and bottom view of the novel presser foot
The intended slot on the botto
135x118mm (300 x 300 DPI)

1
2
3
4
5
6
7
8
9
10
11
12
13
14
15
16
17
18
19
20
21
22
23
24
25
26
27
28
29
30
31
32
33
34
35
36
37
38
39
40
41
42
43
44
45
46
47
48
49
50
51
52
53
54
55
56
57
58
59
60

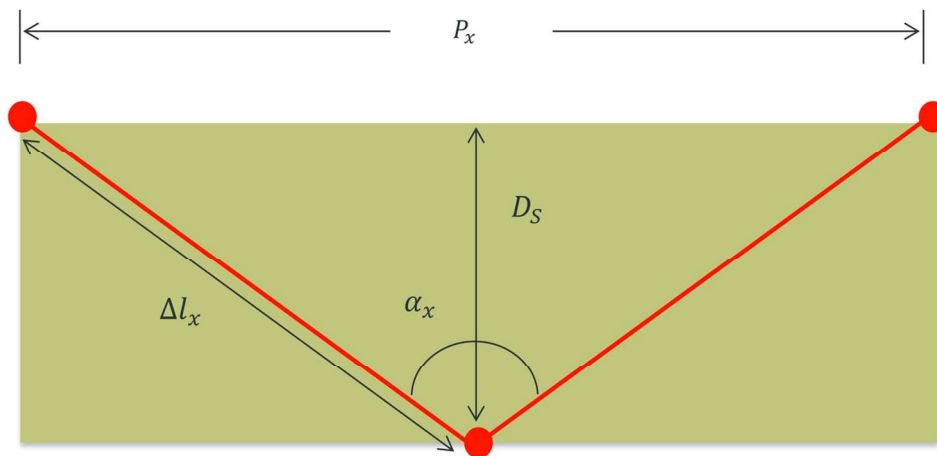

Figure 4 Schematic illustration of the stitch angle
with $x=[60,90,162]$ signifying
119x89mm (300 x 300 DPI)

review

1
2
3
4
5
6
7
8
9
10
11
12
13
14
15
16
17
18
19
20
21
22
23
24
25
26
27
28
29
30
31
32
33
34
35
36
37
38
39
40
41
42
43
44
45
46
47
48
49
50
51
52
53
54
55
56
57
58
59
60

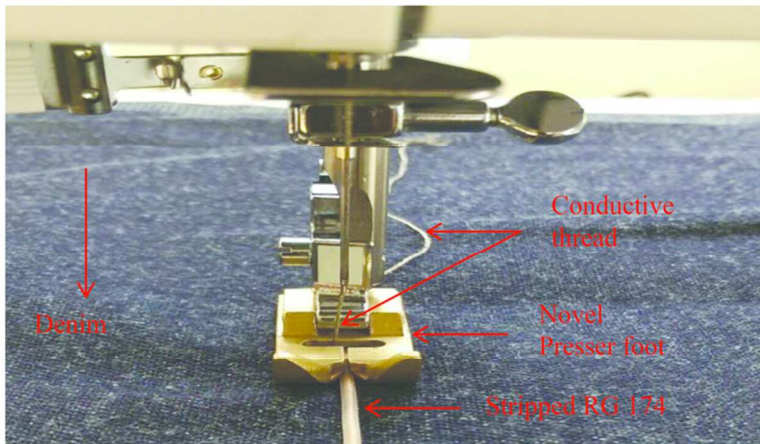

Figure 5 Novel presser foot used with Singer Talent sewing machine during stitching with $x=[60,90,162]$ signifying 84x45mm (300 x 300 DPI)

Peer Review

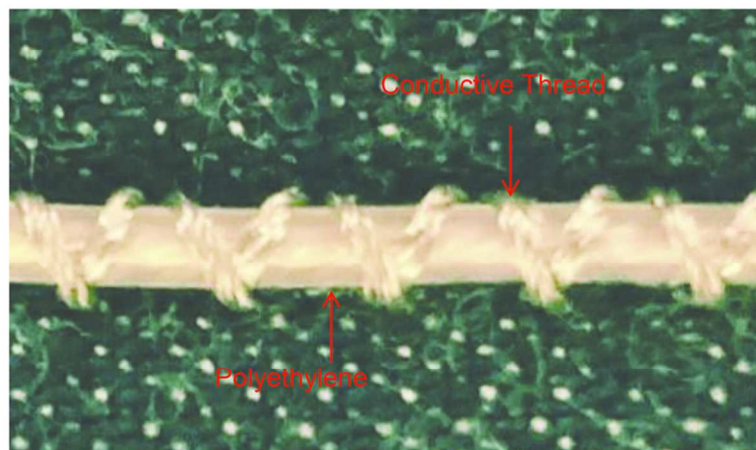

Figure 6 Fabricated stitched transmission line
with $x=[60,90,162]$ signifying
84x45mm (300 x 300 DPI)

1
2
3
4
5
6
7
8
9
10
11
12
13
14
15
16
17
18
19
20
21
22
23
24
25
26
27
28
29
30
31
32
33
34
35
36
37
38
39
40
41
42
43
44
45
46
47
48
49
50
51
52
53
54
55
56
57
58
59
60

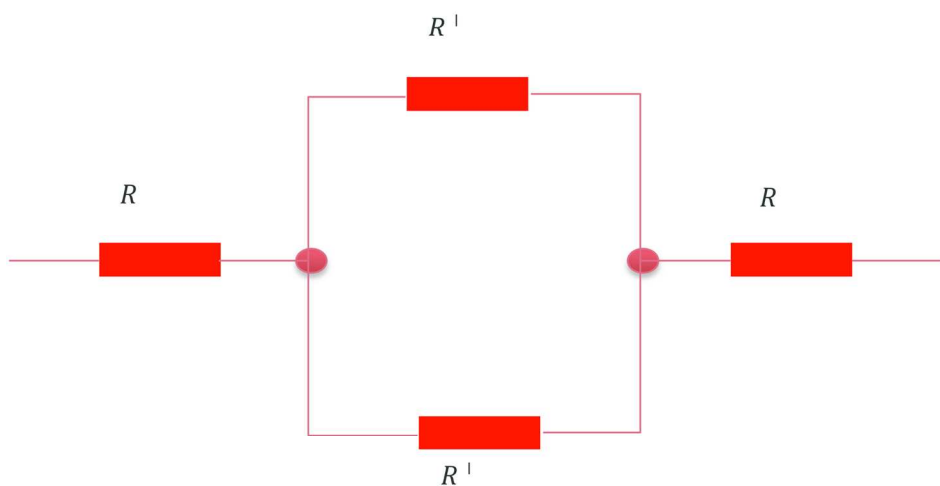

Figure 7 Equivalent electrical model of the stitched transmission line (N=1)
For stitch angles of 85°,65
153x154mm (300 x 300 DPI)

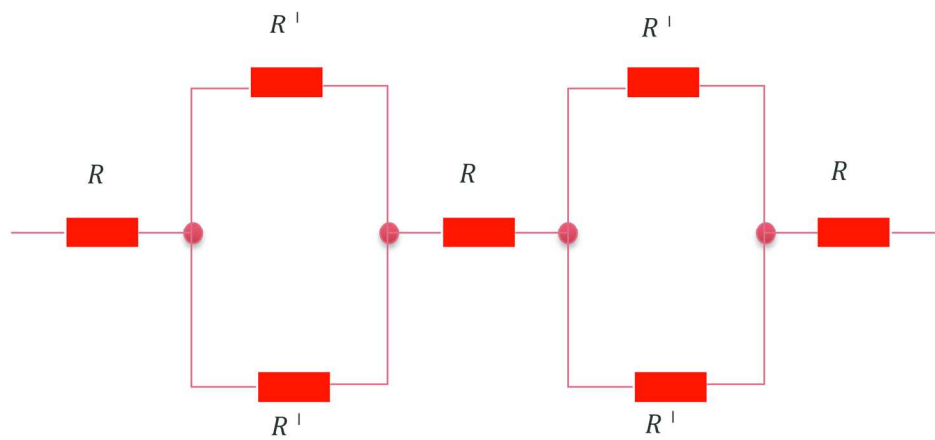

Figure 8 Equivalent electrical model of the stitched transmission line ($N=2$)
 For stitch angles of $85^\circ, 65^\circ$
 161x169mm (300 x 300 DPI)

1
2
3
4
5
6
7
8
9
10
11
12
13
14
15
16
17
18
19
20
21
22
23
24
25
26
27
28
29
30
31
32
33
34
35
36
37
38
39
40
41
42
43
44
45
46
47
48
49
50
51
52
53
54
55
56
57
58
59
60

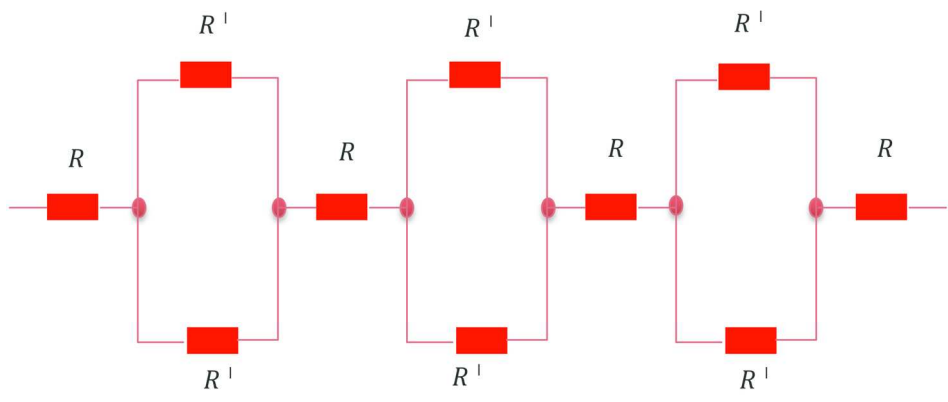

Figure 9 Equivalent electrical model of the stitched transmission line (N=3)
For stitch angles of 85°,65
154x149mm (300 x 300 DPI)



1
2
3
4
5
6
7
8
9
10
11
12
13
14
15
16
17
18
19
20
21
22
23
24
25
26
27
28
29
30
31
32
33
34
35
36
37
38
39
40
41
42
43
44
45
46
47
48
49
50
51
52
53
54
55
56
57
58
59
60

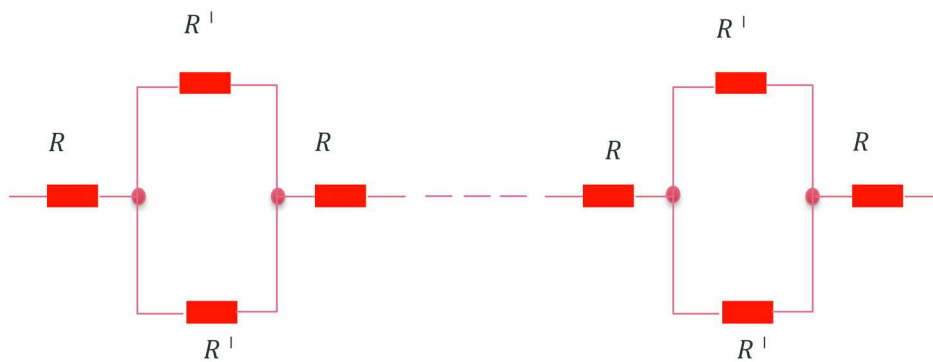

Figure 10 Equivalent electrical model of the stitched transmission line ($N=M$)
 For stitch angles of $85^\circ, 65^\circ$
 177x203mm (300 x 300 DPI)

1
2
3
4
5
6
7
8
9
10
11
12
13
14
15
16
17
18
19
20
21
22
23
24
25
26
27
28
29
30
31
32
33
34
35
36
37
38
39
40
41
42
43
44
45
46
47
48
49
50
51
52
53
54
55
56
57
58
59
60

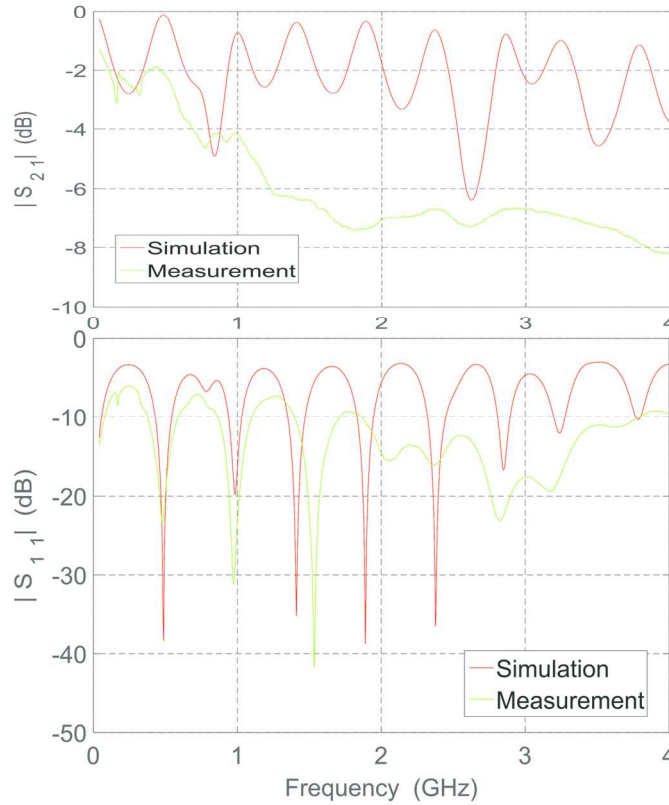

Figure 11 Simulated and measured S-Parameters of stitched transmission line with pitch angle at 85°
The simulation results indicate
142x128mm (300 x 300 DPI)



1
2
3
4
5
6
7
8
9
10
11
12
13
14
15
16
17
18
19
20
21
22
23
24
25
26
27
28
29
30
31
32
33
34
35
36
37
38
39
40
41
42
43
44
45
46
47
48
49
50
51
52
53
54
55
56
57
58
59
60

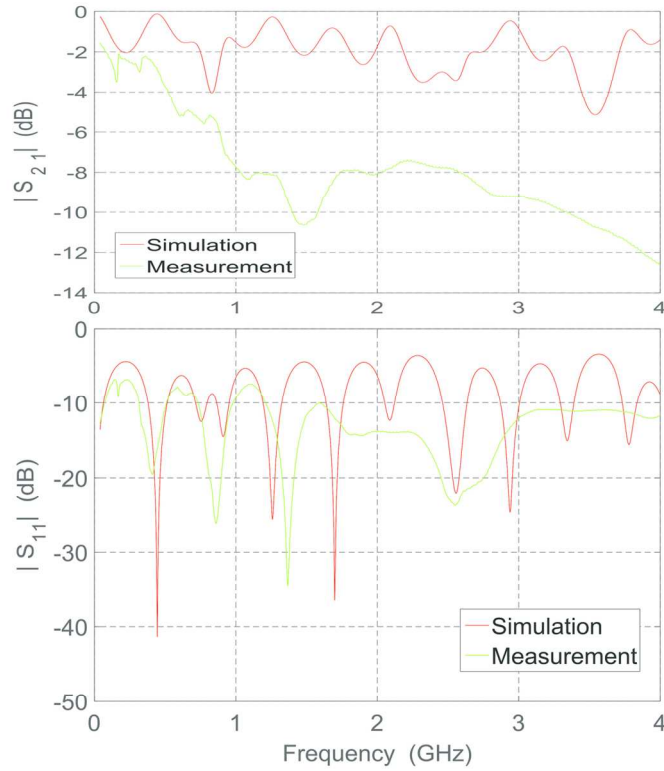

Figure 12 Simulated and measured S-Parameters of stitched transmission line with pitch angle at 65°
The simulation results indicate
142x128mm (300 x 300 DPI)



1
2
3
4
5
6
7
8
9
10
11
12
13
14
15
16
17
18
19
20
21
22
23
24
25
26
27
28
29
30
31
32
33
34
35
36
37
38
39
40
41
42
43
44
45
46
47
48
49
50
51
52
53
54
55
56
57
58
59
60

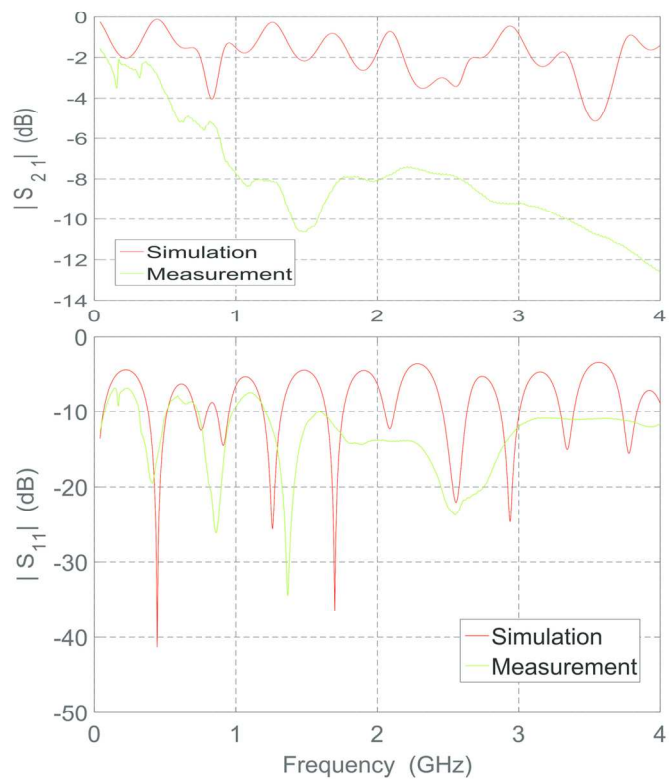

Figure 13 Simulated and measured S-Parameters of stitched transmission line with stitch angle at 31°
The simulation results indicate
142x128mm (300 x 300 DPI)

Braid Angle α_x ($^\circ$)	Number of stitches N	Pitch P_x (mm)	Stitch Length ΔL_x (mm)	Computed DC resistance of the shield (Ω)	Measured DC resistance of shield (Ω)
85	60	2.76	1.69	21	14
65	90	1.94	1.49	27	18
31	162	1.38	1.23	37	27

161x154mm (300 x 300 DPI)

