

## **SOCIAL CAPITAL AND LEARNING ADVANTAGES: A PROBLEM OF ABSORPTIVE CAPACITY**

**Running head:** Social Capital, Learning Advantages, and Absorptive Capacity

### **Mathew Hughes<sup>1</sup>**

Durham University, Durham University Business School, Ushaw College, Durham DH7 9RH  
United Kingdom

Tel: +44 (0)191 33 45906

Fax: +44 (0)191 33 45201

E-mail: [mat.hughes@durham.ac.uk](mailto:mat.hughes@durham.ac.uk)

### **Robert E. Morgan**

Cardiff University, Cardiff Business School, Colum Drive, Cardiff CF10 3EU  
United Kingdom

Tel: +44 (0)29 2087 0001

Fax: +44 (0)29 2087 4419

E-mail: [morganre@cardiff.ac.uk](mailto:morganre@cardiff.ac.uk)

### **R. Duane Ireland**

Texas A&M University, Mays Business School, 4113 TAMU, College Station, TX 77843-4113  
USA

Tel: +1 979 862 3963

Fax: +1 979 845 9641

E-mail: [direland@mays.tamu.edu](mailto:direland@mays.tamu.edu)

### **Paul Hughes**

Durham University, Durham University Business School, Ushaw College, Durham DH7 9RH  
United Kingdom

Tel: +44 (0)191 33 45393

Fax: +44 (0)191 33 45201

E-mail: [paul.hughes@durham.ac.uk](mailto:paul.hughes@durham.ac.uk)

### **KEYWORDS**

Social capital, learning advantages of newness, absorptive capacity, network-based learning, entrepreneurial firms.

---

<sup>1</sup> Corresponding author.

# **SOCIAL CAPITAL AND LEARNING ADVANTAGES: A PROBLEM OF ABSORPTIVE CAPACITY**

## **ABSTRACT**

Theoretically, social capital allows entrepreneurial firms to capitalize on learning advantages of newness and gain access to knowledge as the foundation for improved performance. But this understates its complexity. We consider whether learning through social capital relationships has a direct effect on performance and whether absorptive capacity mediates and moderates this relationship. We find that network-based learning has no direct relationship with performance, but this is mediated in each instance by absorptive capacity and is moderated twice. Our findings challenge the learning advantages of newness thesis, and reveal how absorptive capacity can enable business performance from a firm's network relationships.

## INTRODUCTION

Entrepreneurial firms face resource constraints and knowledge deficits that result in a disproportionately high risk of failure (Freeman, Carroll, and Hannan, 1983). Yet some entrepreneurial firms are able to better organize themselves to outperform others despite the liabilities of newness to which resource constraints and knowledge deficits contribute (Short *et al.*, 2009). In both strategic entrepreneurship and strategic management research, efforts to understand these performance differences have typically focused on firm-based and industry-based explanations. However, an alternative explanation may inform an enhanced understanding of this phenomenon.

Gulati, Nohria, and Zaheer (2000) contend that the performance of entrepreneurial firms can be explained by the nature and network of relationships they possess. Effective networking allows entrepreneurial firms to build high quality ties that enable the transfer of knowledge (Carmeli and Azeroual, 2009), the building of new knowledge (Yli-Renko, Autio, and Sapienza, 2001), and faster and more comprehensive learning (Schulz, 2001). Access to these additional knowledge stocks can improve business performance (Carmeli and Azeroual, 2009), unlock opportunities for growth (Ketchen, Ireland, and Snow, 2007), and offer an opportunity to leverage young entrepreneurial firms' purported learning advantages of newness (Autio, Sapienza, and Almeida, 2000).

To obtain these benefits, entrepreneurial firms must create social capital by networking strategically so as to shape advantageous connections that permit increasing and asymmetrical access to knowledge and thereby stimulate improvements in business performance (Adler and Kwon, 2002; Inkpen and Tsang, 2005; Nahapiet and Ghoshal, 1998; Stuart and Sorenson, 2007). Social capital theory speaks to the nature of the entrepreneurial problem because meaningful

interactions among young firms can catalyze learning advantages of newness by unlocking the knowledge needed to help these firms overcome liabilities of newness and outperform peers.

While the arguments underpinning this alternative explanation may be appealing, we propose two important theoretical tensions that question assumptions about social capital and the learning advantages of newness. First, the effect of any knowledge acquired through social capital relationships on business performance may depend on a firm's absorptive capacity. As a process, absorptive capacity helps a firm convert the knowledge acquired through social capital into valuable learning outcomes relevant to its activities and performance (Volberda, Foss, and Lyles, 2010). Autio *et al.* (2000) proposed that owing to a lack of prior knowledge, young entrepreneurial firms possess learning advantages of newness as they have fewer biases and constraints to grasp novel meanings from knowledge, and by extension from the learning encounters presented through social capital behaviors. By contrast, absorptive capacity arguments suggest that prior knowledge is needed to filter out information and knowledge of little relevance to the firm (Cohen and Levinthal, 1990; Lane and Lubatkin, 1998). This theoretical contradiction warrants attention.

Second, social capital may unlock access to knowledge that does not necessarily meet the entrepreneurial firm's needs (Gulati *et al.*, 2000; Hite and Hesterly, 2001). Hansen (1998) found occasions in which the information benefits of social capital were not cost efficient and Uzzi (1997) reported that it may undermine performance unless safeguards are in place. This presents a theoretical tension when compared to Nahapiet and Ghoshal's (1998) assertion that learning that occurs under conditions of social capital should generate new intellectual capital that directly improves business performance. Consequently, the performance returns from network-based learning may depend on the entrepreneurial firm's absorptive capacity as a means of

identifying, filtering, and applying only the knowledge from network relationships that hold the best value for the firm (Lane and Lubatkin, 1998; Schulz, 2001). Firms that are strongly tied together are more capable of exchanging information (Andersson, Forsgren, and Holm, 2002), and social capital has been associated with more effective transfer of complex knowledge (Sorenson, Rivkin, and Fleming, 2006). But on the basis that an individual firm does not have an equal capacity to learn from all firms to which it is connected (Andersson *et al.*, 2002; Lane and Lubatkin, 1998), its ability to assimilate and deploy knowledge it has gained from network relationships is essential to improved performance. Thus, absorptive capacity is likely to moderate the relationship between network-based learning and business performance.

These theoretical tensions raise three important research questions: (1) What networking behaviors can entrepreneurial firms deploy to generate social capital and unlock network-based learning? (2) Does network-based learning directly improve business performance? (3) Does absorptive capacity both mediate and moderate the relationship between network-based learning and business performance in entrepreneurial firms? Answering these yields four contributions. First, we use social capital and network-based learning theories to offer a relational view of strategic entrepreneurship. This approach answers calls by Carmeli and Azeroual (2009) and Ketchen *et al.* (2007) to increase our understanding of the role of ties in strategic entrepreneurship endeavors. We theorize a model to explain how an entrepreneurial firm's network behaviors begin a process by which it can realize entrepreneurial and strategic benefits, contributing to a call by Stuart and Sorenson (2007) to understand the mechanisms underlying how firms create value from network ties. Second, we challenge the core tenets of the learning advantages of newness thesis put forward by Autio *et al.* (2000) in that we theorize and find that social capital explanations alone do not resolve the entrepreneurial problem of persistent

performance differences among entrepreneurial firms. In uncovering the importance of a firm's absorptive capacity, we cast doubt on present assumptions about how and why young entrepreneurial firms benefit from learning initiatives, and offer solutions to the theoretical tensions we encounter. Third, we theorize absorptive capacity in young entrepreneurial firms as a set of routines to overcome the view of absorptive capacity as prior experience. Fourth, our theorizing and findings challenge Nahapiet and Ghoshal's (1998) view that learning that occurs under conditions of social capital should directly improve business performance. Our study offers a theoretical framework and raises important questions to stimulate further research into social capital, network-based learning, and strategic entrepreneurship.

## **THEORETICAL DEVELOPMENT AND HYPOTHESES**

Insufficient knowledge and ineffective knowledge rejuvenation are key difficulties associated with liabilities of newness (Lane and Lubatkin, 1998). In many instances, these are the conditions that give rise to the entrepreneurial problem of abnormally high failure rates despite disproportionately high successes among some young entrepreneurial firms. Although a firm can create its own unique knowledge over time, the immediate pressures to compete knowledgeably reduce the viability of this approach. Thus, to enhance performance, entrepreneurial firms must immerse themselves in network relationships to combine their own specific knowledge with that of external partners (Yli-Renko *et al.*, 2001).

Combining different knowledge sets effectively can generate relational rents taking the form of rapid knowledge acquisition (Lavie, 2006). But the speed and extent to which an entrepreneurial firm acquires knowledge from its networks depends on the social capital the firm accumulates (Nahapiet and Ghoshal, 1998). A network provides opportunities to access

knowledge but is insufficient to enable the its transfer of that knowledge in value-creating ways (Inkpen and Tsang, 2005)—social capital provides the vehicle for this transfer. By creating social capital the entrepreneurial firm indicates its quality as a partner; in turn, that capital permits knowledge sharing as the foundation for learning to subsequently occur (Inkpen and Tsang, 2005). Differences in creating and using social capital might enable an entrepreneurial firm to create more value than another (Wu, 2008). Without sufficient social capital, a firm might be unwilling to freely make its knowledge available to another owing to little or no shared basis for trust, reciprocity, or expectation for doing so (Adler and Kwon, 2002).

Social capital has typically been studied from the perspective of network structure (Adler and Kwon, 2002) and content (Rodan and Galunic, 2004), despite calls to understand social capital development behaviors (Ng and Feldman, 2010; Stuart and Sorenson, 2007). The extent to which a firm encounters heterogeneous knowledge is dependent on its network behavior. Network behavior leads a firm to maintain unique and idiosyncratic patterns of network linkages and is consequently exposed to different quantities and qualities of knowledge (McEvily and Zaheer, 1999). A firm then varies in its potential to discover and exploit knowledge through its networks. Thus, we emphasizing social capital development behaviors and the behavioral mechanisms through which relationships emerge and value is created.

Defining social capital on the basis of behavior is beneficial as learning consists of a social component that renders it subject to social capital behaviors. Knowledge transfer is only enabled when the firm develops meaningful and trust-based relationships with other firms. The intense, repeated, and close interaction commensurate with social capital creates this trust; but, this requires conscious management action. The inter-firm trust that underpins social capital is itself dependent on a behavioral component capturing the degree of confidence partners have in

each other's reliability and integrity. Such expectations are situated in knowledge-based trust (Gulati, 1995), which depends on the intensity of a firm's networking activities and repetition therein (Wu, 2008); the emergence of shared common standards of activity, expectations of behavior, and beliefs as to the nature and purpose of ties (Gulati *et al.*, 2000; Inkpen and Tsang, 2005; Nahapiet and Ghoshal, 1998); and, resource co-exchange and interdependency among firms recognizing that combining inter-firm resources can lead to joint knowledge creation (Inkpen and Tsang, 2005; Lavie, 2006).

These networking behaviors follow established logic put forward by Adler and Kwon (2002); are consistent with Ng and Feldman's (2010) discussion of social capital development behaviors; and mirror the structural, relational, and cognitive components of social capital (Nahapiet and Ghoshal, 1998). The *structural* component reflects networking behaviors that structure the relationships an actor develops (Nahapiet and Ghoshal, 1998). We define this as networking intensity--the degree to which an entrepreneurial firm seeks out and draws on others to assist in its business activities. Networking intensity captures the extent to which robust patterns of connections will emerge between actors. Firms that actively participate in networks can proactively influence the outcomes as the presence or absence of behavior to shape ties intensively informs the scope for social capital transactions. The *relational* component captures the kind of relations actors have with each other for generating knowledge by leveraging relational assets in the course of business activities (Nahapiet and Ghoshal, 1998; Yli-Renko *et al.*, 2001). We view this as resource interdependency because resource-based ties are of primary concern to resource-constrained entrepreneurial firms as their co-exchange can mitigate liabilities of newness (Brinckmann and Hoegl, 2011; Hite and Hesterly, 2001). Resource interdependency represents a behavioral choice on the part of a firm, and shapes ties that exhibit



greater trust and scope for value creation. The *cognitive* component refers to shared expectations, interpretations, and systems of meaning capturing shared language and codes between firms (Nahapiet and Ghoshal, 1998). We define this as shared creativity norms, which reflect a shared sense of creativity and entrepreneurship common among firms in a network. These norms are products of the behavior of firms, individually and collectively; create cultural compatibility among partnering firms; and, inform and govern knowledge sharing (Adler and Kwon, 2002).

Social capital serves as a public good capturing the favor and trust other actors have towards a focal actor (Inkpen and Tsang, 2005), enabling value creation (Adler and Kwon, 2002). Value creation takes the form of network-based learning. We define network-based learning as the rate at which a firm learns by acquiring knowledge that it recognizes as potentially useful, over and above what it would have gained had it not engaged in collaborative efforts (Lane and Lubatkin, 1998; Lavie, 2006). Efforts to build social capital facilitate network-based learning and subsequently firm performance by affecting the conditions necessary for the exchange and combination of knowledge. Social capital unlocks access to network-based learning opportunities and activates the transfer of knowledge when the firm's social capital behavior builds trust among partners (Brinckmann and Hoegl, 2011; Inkpen and Tsang, 2005). Social capital may substantially increase the learning that occurs as an entrepreneurial firm is rapidly exposed to larger amounts of knowledge when partner firms become increasingly interconnected (Lavie, 2006; Nahapiet and Ghoshal, 1998). We argue that the more an entrepreneurial firm interacts in network relationships through behaviors focused on resource interdependency, intensively building network ties, and establishing common norms among firms in the network, the more likely it can learn an increasing amount of knowledge to *directly* improve its performance, as Nahapiet and Ghoshal (1998) theorized.

Despite its intuitive appeal, the actual performance consequences of network-based learning through social capital are unclear. Burt (1992) and Uzzi (1997) posit that as ties become stronger (when social capital grows), firms can suffer from knowledge redundancy while also becoming progressively insulated from information outside their networks, stagnating performance as a result. Also, knowledge acquired through social capital is causally ambiguous, such that the knowledge acquired may not be suitable to the firm (Gulati *et al.*, 2000; Hite and Hesterly, 2001). But such views are not held unanimously. Other studies posit that engaging in networks provides opportunities to access rich knowledge, information, and experience that can inform the firm's own knowledge stocks to improve performance (Adler and Kwon, 2002; McEvily and Zaheer, 1999; Stuart and Sorenson, 2007).

The purported relationship between a young entrepreneurial firm's network-based learning and its business performance is predicated on the belief that learning advantages of newness exist. Such advantages refer to young firms' ability to harvest and use knowledge to improve firm performance. This is possible because young firms are liberated from the inhibiting influences of prior routines and experience (Autio *et al.*, 2000). Moreover, young firms are believed to have inherent advantages over older firms based on their ability to learn quicker and to use knowledge in more novel ways. However, there are two reasons to challenge these expectations. First, this expectation is at odds with absorptive capacity theory which states that prior knowledge is needed to filter out information that is irrelevant or potentially damaging to the firm (Cohen and Levinthal, 1990). Second, learning advantages of newness cannot be equally distributed among young firms on the basis that a firm does not have an equal capacity to learn from all firms with which it is connected (Andersson *et al.*, 2002; Lane and Lubatkin, 1998).

Without absorptive capacity, a firm is at risk of learning blindly. In inter-firm relationships, inadequate absorptive capacity can result in inappropriate knowledge being brought into the firm as few filters would exist to reconfigure knowledge in line with the firm's emerging knowledge base (Lane and Lubatkin, 1998). Network-based learning might then harm performance in the absence of absorptive capacity or exhibit no meaningful relationship on its own. We conceptualize absorptive capacity in terms of routines, capturing the processes within a young entrepreneurial firm to recognize the value of *new to it* external knowledge, absorb this knowledge, and convert it into productive firm-specific learning outcomes directly relevant to its activities (Lane and Lubatkin, 1998), given the absence of prior knowledge. The extent to which knowledge is readily identified, filtered, assimilated, and applied in a firm is encapsulated by its knowledge sharing routines (Calantone, Cavusgil, and Zhao, 2002), which inform how knowledge is assessed and transferred among employees (Lane and Lubatkin, 1998). Absorptive capacity, as a firm's ability to transform and deploy the knowledge it has gained from network ties, appears critical to its efforts to generate the learning advantages of newness. Figure 1 summarizes our theoretical model.

**[Insert Figure 1 here]**

### **Social capital and network-based learning**

Weaknesses and asymmetries in resource endowments spur young entrepreneurial firms to seek out and engage in resource-based ties (Hite and Hesterly, 2001). Doing so requires the reduction of information asymmetries among partners (Brinckmann and Hoegl, 2011), which can be achieved by close resource-driven interaction among firms in a network (Stuart, Hoang, and Hybels, 1999). Entrepreneurial firms that access and use complementary resources through networks can realize strategic benefits in the flow of learning (Dyer and Singh, 1998). Sharing

co-dependently in the inputs of others can also result in more significant opportunities to learn (Dussauge, Garrette, and Mitchell, 2000); additionally, spillovers accrue as firms idiosyncratically learn by co-exchanging resources. But this learning is dependent on these ties being meaningful to prevent opportunism. This is achieved when resource sharing and interdependency increase among entrepreneurial firms through repeated interaction (Wu, 2008). When a firm builds close resource-based bonds with another set of firms, and makes available its own complementary resources to others in co-exchange, meaningful ties develop exhibiting trust and goodwill. Although a risk of overdependence exists, resource interdependency among interconnected entrepreneurial firms increases their collective understanding about using individual and joint resources in novel ways, increasing the likelihood of network-based learning (Brinckmann and Hoegl, 2011; Lavie, 2006; Wu, 2008). Thus:

*Hypothesis 1. Greater resource interdependency accelerates network-based learning.*

As each firm maintains idiosyncratic patterns of network linkages, it is differentially exposed to new knowledge (McEvily and Zaheer, 1999). Thus, firms that build and maintain repeated, intense, and close interactive relationships can experience more network-based learning. For example, as an entrepreneurial firm maintains more intense interactions with partner firms, participates in networks, and brings participants into its projects and activities, the capital that develops increases knowledge transfer in the form of experience-based knowledge (Koza and Lewin, 1998). Repeated interactions inspire the sharing of detailed information more quickly (Schulz, 2001); and, greater networking intensity increases the transfer of more complex, tacit knowledge with greater quality due to fewer transmission errors (Sorenson *et al.*, 2006). At the minimum, networking intensity should increase a firm's receptivity to information and the transfer of that information, supporting efforts to learn vicariously from others.

A firm is able to learn from network partners when knowledge-based trust is high (Kale, Singh, and Perlmutter, 2000). Such trust emerges among firms the more intensively they interact with each other (Gulati, 1995). Thus, as a young entrepreneurial firm brings in many network participants into its business, its processes, and its projects; involves itself and participates regularly in the network; and attempts to obtain assistance from network firms, the greater is the likelihood that trust forms as knowledge of the firm's intentions and partnership reliability increase. On this basis, intense and repeated interactions can contribute to a freer and greater exchange of information and knowledge between more committed exchange partners. Thus:

*Hypothesis 2. Higher levels of networking intensity accelerate network-based learning.*

Norms reflect shared beliefs, practices, and common ground that characterize the nature of cooperation among firms in a network (Nahapiet and Ghoshal, 1998). Creativity and entrepreneurship represent common ground among young entrepreneurial firms. Both reflect relevant ingredients of an industry recipe among such firms and their common range of experiences encourages the adoption of similar operating policies (Inkpen and Tsang, 2005). Shared norms of creativity help to establish cultural compatibility between partnering firms, inform and shape cooperation, and offer a basis for repeated interactions. In time, these norms operate at the network level and come to represent an institutionalized set of rules that govern appropriate behavior without the need for formal contracts (Gulati *et al.*, 2000). These rules form a governance mechanism that increases knowledge transfer.

Kambil, Eselius, and Monteiro (2000) propose that firms developing shared creativity norms with partners can catalyze their entrepreneurial abilities to generate more learning and to learn faster than commonly is expected of such firms. Reductions in search time also increase this effect. Repeated interactions then constitute an interface for nurturing additional shared

languages to guide exchange partners, enabling these firms to further identify ways to exchange and combine each other's knowledge (Wu, 2008). The existence of implicit norms and rules operating at the network level, having been established and driven by the network cohort, can further facilitate the exchange of knowledge because opportunism would be subject to severe social sanctions (Inkpen and Tsang, 2005). Thus:

*Hypothesis 3. Higher levels of shared creativity norms accelerate network-based learning.*

### **Absorptive capacity and social capital**

A young firm's absorptive capacity consists of processes to recognize the value of new external knowledge, to absorb this knowledge, and to convert it into productive, valuable, and firm-specific learning outcomes directly relevant to its activities (Cohen and Levinthal, 1990; Lane and Lubatkin, 1998). The extent to which knowledge is readily identified, filtered, assimilated, and applied in a firm depends on its knowledge sharing routines (Calantone *et al.*, 2002). Such routines capture the ways in which knowledge is accessed, stored, and transferred in the firm (Lane and Lubatkin, 1998). The assimilation process is then influenced by the clarity of these routines. The greater the extent to which a firm is organized to thoroughly analyze and share information through conversations and meetings and then to apply the lessons drawn from this process to decisions, products, and projects, the greater is its absorptive capacity (Calantone *et al.*, 2002; Lane and Lubatkin, 1998).

Such a view of absorptive capacity identifies two important implications: First, situations that enable knowledge acquisition and expose the firm to new information rapidly increase opportunities to engage in activities underpinning a firm's absorptive capacity. Greater networking intensity presents one such scenario, exposing the firm to more information that is more novel and complex (McEvily and Zaheer, 1999; Sorenson *et al.*, 2006). Intense, close

interactions also increase the idiosyncratic exposure of firms to different interpretations of the meaning and relevance of knowledge (McEvily and Zaheer, 1999). Therefore, greater networking intensity should generate encounters that help the firm improve its own absorptive capacity by increasing opportunities to investigate and interpret information, share it, and apply it internally. Early characterizations of absorptive capacity assume that its growth depends on a firm's prior knowledge stocks (Cohen and Levinthal, 1990), but young entrepreneurial firms lack such stocks (Autio *et al.*, 2000). As networking intensity can expose the firm to considerable information with opportunities to encounter alternative explanations for such information, it would be expected that improvements in absorptive capacity would result. Thus:

*Hypothesis 4. Greater networking intensity is positively related to absorptive capacity.*

Second, absorptive capacity can reshape the extent of learning from networking activities. A greater absorptive capacity should improve a firm's ability to readily identify, filter, and apply *only* the knowledge with the strongest likelihood of facilitating the firm's efforts to improve performance. As a firm's absorptive capacity strengthens, it should become more adept at identifying, isolating, and applying lessons from learning encounters. This should prevent the firm from becoming overloaded with unnecessary information because its ability to process information is superior (Lane and Lubatkin, 1998). Absorptive capacity routines correct for the absence of prior knowledge in young entrepreneurial firms that would otherwise be used to frame and interpret information. The greater the number of routines a firm has in place to absorb and convert knowledge, or the greater its absorptive capacity, the more likely it is to seize the meaning and value of knowledge gained through learning activities, thereby changing the flow of learning away from the mere acquisition of knowledge towards a more focused learning effort (Cohen and Levinthal, 1990). Thus:

*Hypothesis 5. A firm's absorptive capacity negatively moderates the relationship between networking intensity and network-based learning.*

### **Network-based learning, absorptive capacity, and business performance**

As an entrepreneurial firm repeats and maintains its interactions with partner firms, experience-based knowledge can be transferred (Koza and Lewin, 1998), the sharing of detailed information takes place (Schulz, 2001), and in time, the transfer of more complex knowledge can increase (Sorenson *et al.*, 2006). Given that young firms have thin knowledge stocks on which to inform firm performance, it is intuitive to expect that network-based learning rapidly builds a firm's knowledge stocks so that it can compete more effectively. Network-based learning should then increase a firm's knowledge stock beyond those linked to cumulative operating experience (Kim and Miner, 2007), and increase business performance (Nahapiet and Ghoshal, 1998).

Recent theoretical arguments suggest that young entrepreneurial firms have learning advantages of newness owing to little prior knowledge to constrain learning and fewer established routines to slow down learning (Autio *et al.*, 2000; Sapienza *et al.*, 2006). The cumulative effect is an amplified speed of knowledge acquisition that should lead to positive performance returns. The benefits of network-based learning have been associated with improvements in firms' sales cost efficiency, business efficiency, and economic performance (Yli-Renko *et al.*, 2001). Further, Autio *et al.* (2000) find that for an entrepreneurial firm, developing sufficient knowledge stocks facilitates more rapid adaptation to market conditions including the recognition of opportunities for market expansion. Despite some concerns, the logic that new information replenished continuously through social capital relationships should generate the knowledge needed to compete more effectively is intuitively appealing. Thus:



*Hypothesis 6. Network-based learning is positively related to business performance.*

Conceiving of absorptive capacity as a path dependent construct in which a firm's stock of prior knowledge constitutes the basis for knowledge flows within its learning activities (Cohen and Levinthal, 1990) is problematic from the perspective of young entrepreneurial firms in that their lack of prior knowledge causes liabilities of newness. Yet in sharp contrast, young entrepreneurial firms are theorized to exhibit learning advantages of newness as a lack of prior knowledge prevents biased interpretation of information, offers richer scope for novel uses of information, and fewer impediments to learning (Autio *et al.*, 2000). Accordingly, products, projects, decisions, routines, and performance should be easier to modify owing to fewer rigidities and constraints to assimilate, transform, and exploit learning outcomes generated through the firm's absorptive capacity routines. New ventures tend to suffer from a lack of routines which makes using knowledge and reproducing its outcomes consistently difficult (Sine, Mitsuhashi, and Kirsch, 2006). Formalizing absorptive capacity into a set of routines to assimilate, review, share, and put into use learning outcomes generated from knowledge absorption should then generate positive business performance returns to the firm. Formal routines for absorptive capacity should help to fine-tune information processing as a pathway to accruing superior performance. Thus:

*Hypothesis 7. A firm's absorptive capacity is positively related to business performance.*

#### **Absorptive capacity—mediation and moderation effects**

The greater the number of routines a firm has in place to absorb and convert knowledge, or the greater its absorptive capacity, the more likely the firm is to seize the meaning and value of knowledge gained through its learning activities (Cohen and Levinthal, 1990). Being able to do so should increase any positive effect network-based learning might have on performance

because the knowledge acquired would have been filtered to specifically meet the firm's needs (Lane and Lubatkin, 1998; Schulz, 2001).

The knowledge acquired through network relationships might not transfer directly into performance improvements without mechanisms inside the firm to translate often ambiguous knowledge into useable outcomes. Access to a wealth of information alone is inadequate as this information needs to be interpreted and absorbed to remove inappropriate information from being acted on. Routines underpinning absorptive capacity determine a firm's ability to recognize the value of new knowledge and to adapt and apply that new knowledge to its activities. Without adequate absorptive capacity, the firm may acquire a vast amount of knowledge that it is then unable to translate efficiently into critical learning outcomes or effectively put into practice. Thus, any direct effect of network-based learning on business performance may depend on the absorptive capacity of each entrepreneurial firm.

Mere exposure to external knowledge drawn or vicariously learned from others is insufficient to ensure that a young entrepreneurial firm will internalize it successfully or in a manner that is relevant to business performance. While an absence of prior knowledge stocks restricts its ability to interpret newly received knowledge, it offers a potential learning advantage *if* routines supportive of absorptive capacity are in place to explore the applicability and use of acquired knowledge. We propose that the relative flexibility of young entrepreneurial firms can allow them to rapidly benefit from their network-based learning because their absorptive capacity is based not on prior knowledge but on routines. In the absence of prior knowledge stocks, absorptive capacity stems from a firm sharing information internally and encouraging conversations and meetings among individuals to analyze and apply lessons from newly-

acquired knowledge (Calantone *et al.*, 2002; Lane and Lubatkin, 1998). Absorptive capacity can then facilitate a firm's efforts to absorb external knowledge and put it to best use. Thus:

*Hypothesis 8. A firm's absorptive capacity mediates the relationship between network-based learning and business performance.*

*Hypothesis 9. A firm's absorptive capacity positively moderates the relationship between network-based learning and business performance.*

## **METHODS**

### **Sample and respondents**

We empirically tested the arguments flowing from our theoretical framework. Young technology-based entrepreneurial firms located in incubator facilities form our sample. We used the United Kingdom Business Incubation directory and the United Kingdom Science Park Association directory to construct the sample. After searches to verify their operational status and to check for changes to the incubator population, we identified 196 incubator facilities. To capture young technology-based entrepreneurial firms, we screened the incubators and found that 73 percent satisfied our technology-based criterion, yielding a sample population of 143 incubator facilities. A list of the young technology-based firms in each incubator was generated. We then randomly sampled 1,000 incubating young technology-based firms.

To test face and content validities and determine how best to administer the quantitative study, we interviewed five entrepreneurs and two incubator managers. We also pre-tested the survey instrument with scholarly experts. We sought to ensure that our constructs fit with the realities of younger firms (Sine *et al.*, 2006). Suggestions for improving the survey instrument led to minor amendments but no material change in study constructs.

Our interviews identified the *lead entrepreneur* in each firm as the most relevant informant (Hmieleski and Baron, 2008). A firm's founder or top management team leader (i.e., Chief Executive Officer) was selected as the lead entrepreneur. These interviews established that multiple informants would not improve the quality of the data because these single informants exhibited significant, wide, and largely exclusive knowledge of the firm's vision, its activities and routines, and strategic direction (Baum, Locke, and Kirkpatrick, 1998).

We administered a mail survey in multiple waves during 2003. Received practice for survey administration was followed (Slater and Atuahene-Gima, 2004). A total of 211 eligible responses were received. We tested for non-response bias by comparing groups of early and late respondents. We found no statistically significant differences between the groups. To assess the depth of informant validity, we performed a *post hoc* test to evaluate informants' level of knowledge and accuracy regarding their responses (Kumar, Stern, and Anderson, 1993). Both tests yielded high scores and reinforce informant validity.

## **Measures**

Table 1 contains the items used in this study. Unless otherwise stated, all items were measured with a 7-point Likert response anchored (1) *strongly disagree* to (7) *strongly agree*. The social capital constructs were modeled after Adler and Kwon (2002) and Nahapiet and Ghoshal (1998). We measured resource interdependency by sourcing related items from Sarkar *et al.*'s (2001) resource complementarity and reciprocal commitment scales. We sought to capture the extent to which networking firms provided resources valuable for each other that would be difficult to obtain elsewhere. Networking intensity measures were developed from McEvily and Zaheer's (1999) networking participation scales and Yli-Renko *et al.*'s (2001) social interaction and network ties scales. We focused our scales on the regularity at which a firm participates in

networks. Shared creativity norms were measured with reference to Sarkar *et al.*'s (2001) scales on cultural compatibility; but, we modified these to focus on network conditions attributable to our context. Our attention was on shared common standards of activity, expectations of behavior, and beliefs as to the nature and purpose of ties (Gulati *et al.*, 2000).

Network-based learning was measured using Sarkar *et al.*'s (2001) reciprocal information exchange and strategic performance scales. These scales, focused on collaboration as an effective medium for learning, correlated directly with our definition of network-based learning and are consistent with Kim and Miner's (2007) view that vicarious learning from others increases a firm's knowledge stocks beyond those linked to cumulative operating experience alone. Absorptive capacity scales was sourced from Calantone *et al.*'s (2002) intraorganizational knowledge sharing scales. We operationalized absorptive capacity in young entrepreneurial firms as routines for sharing, interpreting, and assimilating information in the firm, reflecting its efforts to build an absorptive capacity.

We operationalized business performance in four ways. Market performance measures were drawn from Morgan and Strong (2003). Actual sales performance was measured and despite respondents' non-receptivity to divulge this information, 147 provided these data. The correlation between market performance and sales performance is 0.36 ( $p \leq 0.01$ ). Response performance was measured with items that captured a firm's ability to adapt to change and respond promptly to opportunities and threats (c.f. Krohmer, Homburg, and Workman, 2002) (anchored (1) *very poor* to (7) *excellent*). While complete and comparable objective data is scarce for the firms in our sample, we acquired the Total Exemption Small accounts<sup>2</sup> of respondent firms to obtain data on net profit performance for 2004 and to calculate profit growth

---

<sup>2</sup> Total Exemption Small accounts are abbreviated balance sheets containing limited information that are submitted to the public repository. We acquired these accounts from the Government Agency 'Companies House'.

(percentage change between 2003 and 2004) as two *lagged* dimensions of business performance. The net profit data were standardized (*z*-score) for data analysis.

Six control variables are included. Firm size and firm age are associated with greater internal resource stocks, which might enable a firm to apply knowledge more readily to improve performance. We controlled for incubator size because greater (or lower) incubator size might grant access to a larger (or smaller) incubator network thereby increasing (or decreasing) opportunities for value creation. We documented the number of firms in each facility to constitute incubator size. Ranked facility type required respondents to specify the sort of center/park/incubator they were located in as more sophisticated ones might offer better networking and learning opportunities. The scale consisted of: managed workspace (1; low); enterprise center (2); innovation center, technology center, and other (3; midpoint types); business incubator (4); and, science park (5; high). Localized relational embeddedness with other incubating firms and externalized relational embeddedness with firms outside the incubatee cohort capture the possibility that firms might learn differently within different networks (Inkpen and Tsang, 2005). Items were drawn from Andersson *et al.* (2002).

Asymmetric relationships can exhibit power imbalances that hamper learning or harm firm performance. To determine whether power (im)balances exist within groups of firms based in the same incubator in our sample, we grouped all sample respondents by incubator, assigning each a code, then used an ANOVA test based on General Linear Model analysis to make within-subject comparisons for each group. Our respondents were spread across 52 incubators; 13 of these contained only a single respondent and were as a result removed from this analysis. With 39 groups, representing 198 respondents we created a latent construct termed Power Balance (3 items; factor loadings  $\geq 0.8$ ;  $\alpha = 0.82$ ) to perform within-group statistical analysis. No

statistically significant deviations from the mean within each group were found, confirming a power *balance* within each group, indicating no within-group differences.

**[Insert Table 1 here]**

We followed *a priori* Spector and Brannick's (1995) protocol for limiting common method variance (CMV). In addition, two *post hoc* techniques were used for the purpose of assessing the extent of such potential bias. First, we employed the *Harman one-factor test* (Podsakoff *et al.*, 2003). We specified all variables in a single-factor confirmatory factor analysis and examined fit indices to determine whether a single latent factor would pose an alternative explanation to the analysis. The results reveal no such explanation with unacceptable model fit (Hu and Bentler, 1999; Kline, 1998):  $\chi^2 = 4036.16$ , d.f. = 779,  $p < 0.01$ , RMSEA = 0.18, NNFI = 0.78, CFI = 0.79, IFI = 0.79, GFI = 0.39.

Second, we performed a modified Lindell and Whitney (2001) *marker variable test*. We first identified a marker variable—not *theoretically* related to all other measures in a study. Following Podsakoff, MacKenzie, and Podsakoff (2012) we selected an item--not a scale-level marker. We used respondent years of working experience as our marker. Non-significant correlations ( $p > 0.05$ ) were found between this variable and all study variables. A robust examination of CMV should examine how covariance between variables is affected by the common method, as tests based on correlation would not control for potential CMV effects. We calculated average covariance (c.f. Malhotra *et al.*, 2006) as:  $r_m = -1.30524$ . From this, CMV-adjusted covariances between all the measures in the study were calculated. The modified covariance matrix was then used by re-specifying the original CFA measurement model. The results show that with CMV-adjusted covariance, the changes in the measurement model were non-significant. The substitution slightly deteriorated model fit ( $\Delta\chi^2 = 29.82$ ;  $\Delta df = 0$ ;  $\Delta RMSEA$

= 0.01) but slightly improved some fit indices ( $\Delta\text{CFI}$  and  $\Delta\text{IFI} = 0.03$ ;  $\Delta\text{NNFI} = 0.04$ ). On balance, we cannot entirely exclude the presence of CMV but suggest that it does not appear to be a threat and as such, is unlikely to explain the relationships found.

### **Reliability and validity**

Scales were examined using exploratory factor analysis to identify items for removal (not reported), prior to confirmatory factor analysis. Using LISREL 8.8 with maximum likelihood estimation and the covariance matrix, we estimated a single measurement model (Table 1). This model ( $\chi^2 = 1158.46$ ; d.f. = 680;  $p < 0.01$ ) exhibited excellent fit to the data (CFI = 0.95; IFI = 0.95; NNFI = 0.94; RMSEA = 0.07). Each item loaded significantly ( $p < 0.01$ ) onto the specified construct (ranging from 0.52 to 0.97); the average variance extracted (AVE) ranged from 0.57 to 0.86, satisfying the 50 percent threshold for convergent validity; the square of the AVE for each construct is greater than the off-diagonal coefficients, evidencing discriminant validity (Table 2); and, the alpha coefficients and the composite reliabilities all exceed the 0.70 threshold for acceptable reliability. Scales were constructed for further analysis using the average score of items for each construct. Table 2 reports their descriptive properties.

**[Insert Table 2 here]**

## **RESULTS**

Five structural models were specified. SEM Model 1 focused on the initial parts of our hypothesized model, with the dependent variable specified as network-based learning. SEM Models 2–5 are identical with each focusing on the latter part of our model but with the dependent variable representing a different form of performance. For each structural model, we specified additional restricted and unrestricted SEM models to assess whether the *interaction*



*term effects* were significant. The model fit results for all models are shown in Table 3. For SEM models 1, 2, and 3, significant differences between the restricted and unrestricted models exist, and as the AIC values for the unrestricted models are also lower, we conclude that the unrestricted models are superior. For SEM models 4 and 5, no significant differences between the restricted and unrestricted models are found. However, examining for absolute differences in model fit statistics reveals that the  $\chi^2$  values are lower for the unrestricted models, and in SEM Model 4 improvements in CFI are also found. Thus, we conclude that it is appropriate to use the data from the unrestricted models for our hypotheses tests. The results are presented in Table 4.

**[Insert Tables 3 and 4 here]**

Hypotheses 1–5 are featured in SEM Model 1. The hypothesized relationships explain 78 percent of variance in network-based learning, suggesting our model is robust. The results support Hypotheses 1 and 2 with resource interdependency and network intensity, respectively, being positively related to network-based learning. However, shared norms (H3) have no influence. Network intensity is also positively related to absorptive capacity, supporting H4. Absorptive capacity was hypothesized to negatively moderate the relationship between network intensity and network-based learning (H5). The results support this hypothesis.

SEM Models 2–5 address business performance (hypotheses H6–H9). Absorptive capacity is positively related to market performance, response performance, net profit, and profit growth. All paths are significant, fully supporting H7. Regarding H6, we posited that network-based learning would be positively related to business performance. We find no support for H6, with the exception of response performance where the path is significant but negative.

Hypothesis 8 posits a mediation effect by absorptive capacity between network-based learning and business performance. For mediation to exist there must be a significant relationship

between absorptive capacity and performance. We use the Sobel Test (one-tailed) to determine the extent of mediation. For full mediation, the Sobel test Z-value must exceed 1.645 for 5% significance (or 1.282 for 10% significance) and the effect ratio should exceed 0.8; for partial mediation, the Sobel test Z-value must exceed 1.645 (or 1.282 for 10% significance) and the effect ratio be lower than 0.8 (Ndofor, Sirmon, and He, 2011). This mediation effect is supported as the path from absorptive capacity to performance is positive and significant for all forms of performance and the mediation effect is partial in each case (Appendix). In the case of response performance, the mediation effect is important as network-based learning has a negative effect on response performance, but has a positive effect on absorptive capacity which, in turn, has a positive effect on response performance.

Hypothesis 9 proposes that absorptive capacity moderates positively the direct relationship between network-based learning and performance. This is the case for market performance and response performance, supporting H9. The moderation effect is important in both cases as network-based learning exhibited no direct effect on market performance and a direct negative effect on response performance.

## **DISCUSSION AND CONCLUSIONS**

This work is framed around important theoretical inconsistencies about the role social capital plays in resolving the entrepreneurial problem faced by young firms. Autio *et al.* (2000) proposed that young entrepreneurial firms possess learning advantages of newness as they exhibit an absence of prior knowledge and routines that typically limit the acquisition of new knowledge. But our work suggests that there appear to be learning constraints of newness for this very reason. Our findings point toward a theoretical contradiction in that the absence of prior

knowledge constrains a firm's ability to convert the learning it achieves through social capital behaviors into significant performance returns.

Classic and recent treatments of absorptive capacity argue that prior knowledge provides firms with the lens to filter out information of little relevance (Cohen and Levinthal, 1990; Lane and Lubatkin, 1998). In the absence of prior knowledge and absorptive capacity, the firm appears to be more likely to accept information without attenuating it, resulting in failures to appreciate its potential consequences and being unable to understand its application.

We find that absorptive capacity positively moderates the relationship between network-based learning and market and response performance, and itself has a direct positive relationship with all forms of performance. Absorptive capacity also mediates the relationship between network-based learning and business performance in each instance. These insights point to inadequacies in the learning process as a fundamental explanation for the persistence of performance differences among young firms. Our findings thus contribute to research on the entrepreneurial problem

Our main contributions include the introduction of learning constraints of newness and evidence of the primacy of absorptive capacity in shifting from these constraints towards learning advantages. A common belief is that performance changes are a product of learning. But we find that the contributions of network-based learning towards this endeavor are hindered by an inability to absorb knowledge and an oversimplification of alleged learning advantages of newness. We conclude that firms that invest in routines underpinning absorptive capacity are best positioned to gain from any such potential learning advantages.

The apparent breakdown in transforming network-based learning into performance outcomes might be explained by the processes at play. While a collaborative approach promotes

high receptivity and transparency among firms with respect to knowledge acquisition, a lack of established routines to assimilate and integrate that knowledge with on-going learning (absorptive capacity) reduces the likelihood that new learning will manifest in improved performance. Autio *et al.* (2000) and Sapienza *et al.* (2006) propose that a lack of established routines is advantageous as routines slow down learning and its transfer into performance improvements. However, we suggest it is this very routinization through absorptive capacity that establishes a learning advantage and drives improvements in firm performance. Not everything that is learned is valuable or meaningful. Without routines to digest, interpret, assimilate, and absorb new knowledge (in the absence of prior knowledge) a young firm risks accommodating learning that are irrelevant to its performance.

A second contribution is the doubt these findings cast on Nahapiet and Ghoshal's (1998) argument that learning that occurs under conditions of social capital should directly improve business performance. Our reporting of problems with translating social capital investments into value creation is not entirely novel (Gulati *et al.*, 2000; Hansen, 1998; Hite and Hesterly, 2001; Uzzi, 1997); but, we offer new explanations for this result. Specifically, we find that social capital varies the conditions needed to unlock the knowledge that might help address the entrepreneurial problem. The effects of social capital behaviors on network-based learning are not uniform implying that this black box remains a conundrum. We find that social capital built around efforts to establish resource co-exchange and interdependency and increased networking intensity improve network-based learning. Increases in networking intensity also positively enhance a firm's absorptive capacity as a precursor to improving business performance.

Our results indicate that social capital development behaviors are not equally valuable to unlocking improvements in intellectual capital, which challenges expectations set out by

Nahapiet and Ghoshal (1998). Superior value accrues to those young firms that invest in resourcing activities and networking intensity. Following Stuart and Sorenson (2007), we suggest that young firms behaving strategically along these social capital dimensions stand the best chance of resolving the entrepreneurial problem. Our findings also suggest that theorizing and testing the direct effects of social capital masks its potential contribution if moderation and mediation effects are unaccounted for. Nahapiet and Ghoshal (1998) speculated that some components of social capital might antagonize rather than support information exchange; rather, the problem appears to lie in converting network-based learning from social capital behaviors into performance returns. The resolution, it appears, lies in absorptive capacity.

These findings also contribute to the theoretical and empirical development of social capital in the context of strategic entrepreneurship and address calls to better understand how firms' relational ties benefit from strategic entrepreneurship endeavors (Carmeli and Azeroual, 2009; Ketchen *et al.*, 2007). This contribution takes the form of a framework that accounts for absorptive capacity as a fundamental explanation of superior performance resulting from a young entrepreneurial firm's networking initiatives.

We propose that advantage accrues to entrepreneurial firms that are able to put meaning to the vast knowledge that social capital unlocks, and, those that effectively absorb and assimilate this knowledge into the firm's activities are best positioned competitively. Notably, while network-based learning has no significant positive effect on performance, it does positively influence absorptive capacity in each of our models and this then mediates the relationship between network-based learning and business performance in each instance. These findings contribute to the relational view of competitive advantage (Dyer and Singh, 1998) and help reconcile theoretical tensions among social capital, learning advantage, and absorptive

capacity theories. Autio *et al.* (2000, p.922) postulated that research would be well-served to ‘examine in more depth issues of the speed of learning as well as the durability of potential learning advantages of newness.’ We do so and extend the relational view of competitive advantage and learning advantage theory toward the logic of strategic entrepreneurship.

### **Limitations and future research**

This study has several limitations. First, the cross-sectional method imposes certain restrictions but points to the value of further research examining how social capital and network-based learning affect the business performance of young entrepreneurial firms over time. This might be achieved by unraveling the linearity of Nahapiet and Ghoshal’s (1998) argument to examine how social capital evolves and the time-based effects of network-based learning. Second, our empirical context limits the generalization of our results to young technology-based incubating firms. Third, there is a non-trivial possibility that the self-selection of a young technology-based firm into an incubator facility is not random and risks introducing bias or endogeneity into our empirical model. Consequently, we advocate for more research into other types of young entrepreneurial firms to generate additional empirical evidence about the theoretical concerns we raise herein. Fourth, different types of network-based learning are unaccounted for in this work. Although the emphasis was on external knowledge acquisition, we choose not to limit the forms of that knowledge. This approach is consistent with a process-based view of learning (Bell, Whitwell, and Lukas, 2002), but detracts from the richness of the conclusions we can draw about the nature of network-based learning from social capital and its implications. This requires attention in future studies.

The study raises several important directions for future research. While we have only limited understanding of how young entrepreneurial firms acquire learning advantages of

newness, it seems necessary to investigate whether learning advantages simply exist in young firms (owing to fewer apparent learning constraints) or whether entrepreneurs must amend specific firm activities to enable such advantages. The young technology-based entrepreneurial firms in our sample appear to exhibit learning constraints of newness unless a strategy is formed to build absorptive capacity and use it to extract better learning from its networking activity. Learning advantages might then be activated. Our findings suggest that assuming the existence of learning advantages of newness in the absence of such conditions leads to a flawed theoretical expectation. We find that absorptive capacity is an important mediator of the relationship between network-based learning and business performance. Full mediation is rare and evidence of partial mediation suggests a need to identify additional indirect effects.

We find evidence that developing social capital on its own is insufficient to secure improvements in performance for young entrepreneurial firms. We add to concerns about the translation of social capital investments into value creation, and it seems that Rodan and Galunic's (2004) unease about the popularity of social capital outpacing its conceptual development remains valid. We encourage scholars to carry out a thorough assessment of social capital in light of the tensions raised by this study.

In conclusion, we believe that social capital and network-based learning are the basis for forming an array of interesting questions for strategic entrepreneurship scholars to pursue. The findings we report reveal that network-based explanations cannot be divorced from firm-based explanations if scholars and managers are to understand the nature of the entrepreneurial problem and identify the means to benefit from strategic entrepreneurship endeavors.

## **ACKNOWLEDGEMENTS**

The authors thank United Kingdom Business Incubation for their assistance in the data generation phase of this study. Support provided by John Cadogan is also appreciated. The authors also acknowledge the constructive comments and helpful feedback of SEJ Associate Editor Robert Burgelman and the three anonymous reviewers in the development of this work.

## REFERENCES

- Adler PS, Kwon S-W. 2002. Social capital: prospects for a new concept. *Academy of Management Review* **27**: 17–40.
- Andersson U, Forsgren M, Holm U. 2002. The strategic impact of external networks: subsidiary performance and competence development in the multinational corporation. *Strategic Management Journal* **23**: 979–996.
- Autio E, Sapienza HJ, Almeida JG 2000. Effects of age at entry, knowledge intensity, and imitability on international growth. *Academy of Management Journal* **43**: 909–924.
- Baum JR, Locke, EA, Kirkpatrick, SA. 1998. A longitudinal study of the relation of vision and vision communication to venture growth. *Journal of Applied Psychology* **83**: 43–54.
- Bell SJ, Whitwell GJ, Lukas BA. 2002. Schools of thought in organizational learning. *Journal of the Academy of Marketing Science* **30**(1): 70–86.
- Brinckmann J, Hoegl M. 2011. Effects of initial teamwork capability and initial relational capability on the development of new technology-based firms. *Strategic Entrepreneurship Journal* **5**(1): 37–57.
- Burt RS. 1992. *Structural Holes: The Social Structure of Competition*. Harvard University Press: Cambridge, MA.



- Calantone RJ, Cavusgil ST, Zhao Y. 2002. Learning orientation, firm innovation capability, and firm performance. *Industrial Marketing Management* **31**: 515–524.
- Carmeli A, Azeroual B. 2009. How relational capital and knowledge combination capability enhance the performance of work units in a high technology industry. *Strategic Entrepreneurship Journal* **3**: 85–103.
- Cohen WM, Levinthal DA. 1990. Absorptive capacity: a new perspective on learning and innovation. *Administrative Science Quarterly* **35**: 128–152.
- Dussauge P, Garrette B, Mitchell W. 2000. Learning from competing partners: outcomes and durations of scale and link alliances in Europe, North America and Asia. *Strategic Management Journal* **21**: 99–126.
- Dyer JH, Singh H. 1998. The relational view: cooperative strategy and sources of interorganizational competitive advantage. *Academy of Management Review* **23**: 660–679.
- Freeman J, Carroll GR, Hannan MT. 1983. The liability of newness: age dependency in organizational death rates. *American Sociological Review* **48**: 692–710.
- Granovetter M. 1985. Economic action and social structure: the problem of embeddedness. *American Journal of Sociology* **91**(3): 481–510.
- Gulati R. 1995. Does familiarity breed trust? The implications of repeated ties for contractual choice in alliances. *Academy of Management Journal* **38**: 85–112.
- Gulati R, Nohria N, Zaheer A. 2000. Strategic networks. *Strategic Management Journal* **21**: 203–215.
- Hansen MT. 1998. Combining network centrality and related knowledge: explaining effective knowledge sharing in multiunit firms. Working Paper, Harvard Business School, Boston, MA.

- Hmieleski KT, Baron RA. 2008. Regulatory focus and new venture performance: A study of entrepreneurial opportunity exploitation under conditions of risk versus uncertainty. *Strategic Entrepreneurship Journal* **2**: 285–299.
- Hite JM, Hesterly WS. 2001. The evolution of firm networks: from emergence to early growth of the firm. *Strategic Management Journal* **22**: 275–286.
- Hu L, Bentler PM. 1999. Cutoff criteria for fit indices in covariance structure analysis: conventional criteria versus new alternatives. *Structural Equation Modeling* **6**: 1–55.
- Inkpen AC, Tsang EWK. 2005. Social capital, networks, and knowledge transfer. *Academy of Management Review* **30**: 146–165.
- Kambil A, Eselius ED, Monteiro KA. 2000. Fast venturing: the quick way to start web businesses. *Sloan Management Review* **41**(4): 55–67.
- Kale P, Singh H, Perlmutter H. 2000. Learning and protection of proprietary assets in strategic alliances: building relational capital. *Strategic Management Journal* **21**: 217–237
- Ketchen DJ, Ireland RD, Snow CC. 2007. Strategic entrepreneurship, collaborative innovation, and wealth creation. *Strategic Entrepreneurship Journal* **1**(3-4): 371–385.
- Kim J-Y, Miner AS. 2007. Vicarious learning from the failures and near-failures of others: evidence from the U.S. commercial banking industry. *Academy of Management Journal* **50**(3): 687–714.
- Kline, RB. 1998. *Principles and Practice of Structural Equation Modeling*. Guilford Press: New York.
- Koza MP, Lewin AY. 1998. The co-evolution of strategic alliances. *Organization Science* **9**: 255–264.

- Krohmer H, Homburg C, Workman JP. 2002. Should marketing be cross-functional? Conceptual development and international empirical evidence. *Journal of Business Research* **55**: 451–465.
- Kumar N, Stern LW, Anderson JC. 1993. Conducting inter-organizational research using key informants. *Academy Management Journal* **39**: 340–367.
- Lane PJ, Lubatkin M. 1998. Relative absorptive capacity and interorganizational learning. *Strategic Management Journal* **19**: 461–477.
- Lavie D. 2006. The competitive advantage of interconnected firms: an extension of the resource-based view. *Academy of Management Review* **31**: 638–658.
- Lindell MK, Whitney DJ. 2001. Accounting for common method variance in cross-sectional designs. *Journal of Applied Psychology* **86**: 114–121.
- Malhotra NK, Kim SS, Patil A. 2006. Common method variance in IS research: A comparison of alternative approaches and a reanalysis of past research. *Management Science* **52**: 1865–1883.
- McEvily B, Zaheer A. 1999. Bridging ties: a source of firm heterogeneity in competitive capabilities. *Strategic Management Journal* **20**: 1133–1156.
- Morgan R E, Strong CA. 2003. Business performance and dimensions of strategic orientation. *Journal of Business Research* **56**: 163–176.
- Nahapiet J, Ghoshal S. 1998. Social capital, intellectual capital, and the organizational advantage. *Academy of Management Review* **23**: 242–266.
- Ndofor HA, Sirmon DG, He X. 2011. Firm resources, competitive actions and performance: investigating a mediated model with evidence from the in-vitro diagnostics industry. *Strategic Management Journal* **32**(6): 640–657.

- Ng TWH, Feldman DC. 2010. The effects of organizational embeddedness on development of social capital and human capital. *Journal of Applied Psychology* **95**(4): 696–712.
- Podsakoff PM, MacKenzie SB, Podsakoff NP. 2012. Sources of method bias in social science research and recommendations on how to control it. *Annual Review of Psychology* **63**: 539–596.
- Podsakoff PM, MacKenzie SB, Lee J-Y, Podsakoff NP. 2003. Common method biases in behavioral research: a critical review of the literature and recommended remedies. *Journal of Applied Psychology* **88**: 879–903.
- Rodan S, Galunic C. 2004. More than network structure: how knowledge heterogeneity influences managerial performance and innovativeness. *Strategic Management Journal* **25**(6): 541–562.
- Sapienza HJ, Autio E, George G, Zahra SA. 2006. A capabilities perspective on the effects of early internationalization of firm survival and growth. *Academy of Management Review* **31**(4): 914–933.
- Sarkar MB, Echambadi R, Cavusgil ST, Aulakh PS. 2001. The influence of complementarity, compatibility and relationship capital on alliance performance. *Journal of the Academy of Marketing Science* **29**: 358–373.
- Schulz M. 2001. The uncertain relevance of newness: organizational learning and knowledge flows. *Academy of Management Journal* **44**: 661–681.
- Short JC, McKelvie A, Ketchen DJ, Chandler GN. 2009. Firm and industry effects on firm performance: A generalization and extension for new ventures. *Strategic Entrepreneurship Journal* **3**: 47–65.

- Sine WD, Mitsuhashi H, Kirsch DA. 2006. Revisiting Burns and Stalker: formal structure and new venture performance in emerging economic sectors. *Academy of Management Journal* **49**(1): 121–132.
- Slater SF, Atuahene-Gima K. 2004. Conducting survey research in strategic management. In *Research Methodology in Strategy and Management*, Ketchen D, Bergh D (eds). Elsevier: New York: 227–250.
- Sorenson O, Rivkin JW, Fleming L. 2006. Complexity, networks and knowledge flow. *Research Policy* **35**(7): 994–1017.
- Spector PE, Brannick MT. 1995. The nature and effects of method variance in organizational research. In *International Review of Industrial and Organizational Psychology* **10**, Cooper CL, Robertson IT (eds). Wiley: Chichester, U.K.: 249–274.
- Stuart TE, Hoang H, Hybels RC. 1999. Interorganizational endorsements and the performance of entrepreneurial ventures. *Administrative Science Quarterly* **44**(2): 315–349.
- Stuart TE, Sorenson O. 2007. Strategic networks and entrepreneurial ventures. *Strategic Entrepreneurship Journal* **1**(3-4): 211–227.
- Uzzi B. 1997. Social structure and competition in interfirm networks: the paradox of embeddedness. *Administrative Science Quarterly* **42**: 35–67.
- Volberda H, Foss NJ, Lyles MA. 2010. Absorbing the concept of absorptive capacity: how to realize its potential in the organization field. *Organization Science* **21**: 931-951.
- Wu W-P. 2008. Dimensions of social capital and firm competitiveness improvement: the mediating role of information sharing. *Journal of Management Studies* **45**: 122–146.
- Yli-Renko H, Autio E, Sapienza HJ. 2001. Social capital, knowledge acquisition, and knowledge exploitation in young technology-based firms. *Strategic Management Journal* **22**: 587–613.

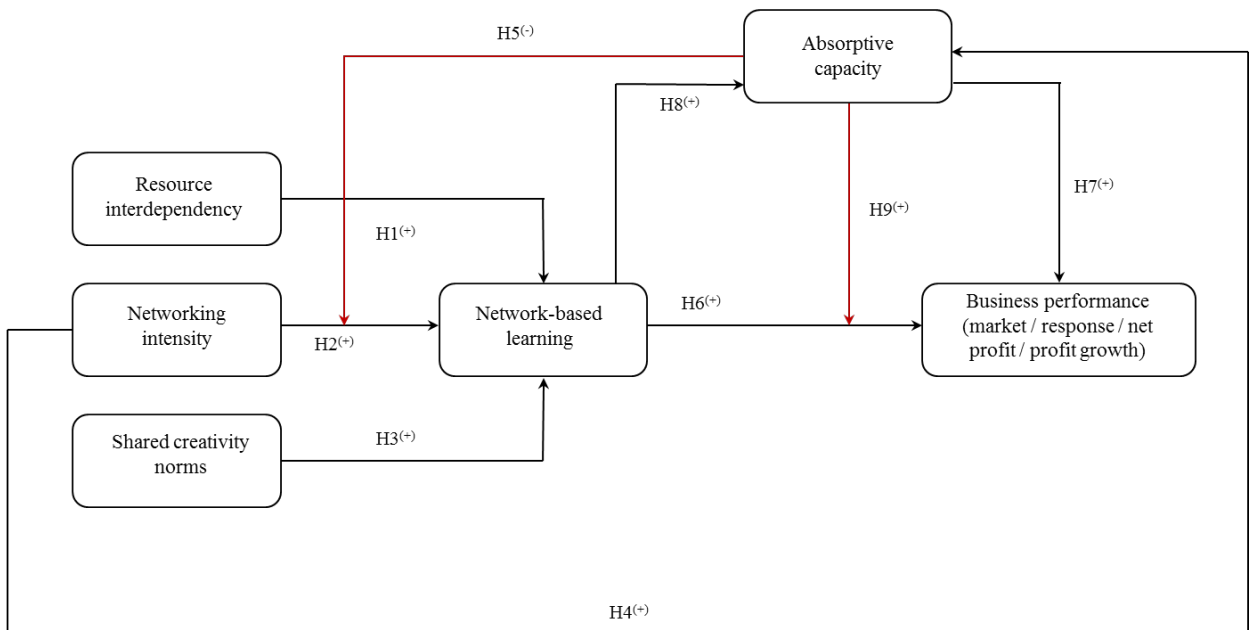

Controlling for:  
 Ranked incubator type, incubator size, firm age, firm size, relational embeddedness with external firms, relational embeddedness with internal/local firms

**Figure 1. Hypothesized model**

**Table 1. Confirmatory factor analysis results**

Construct	Item	Mean (s.d.)	Standardized factor loading	Standardized error variance	t-value
<b>Shared norms</b>	A creative and vibrant atmosphere exists within the incubator	4.16 (1.61)	0.87	0.24	12.31
	Businesses in the incubator share a common feeling of creativity	3.80 (1.53)	0.91	0.16	13.40
	There is an innovative 'feel' throughout the incubator	3.95 (1.62)	0.94	0.11	14.09
	The incubator generates a creative environment to explore and experiment	3.85 (1.67)	0.87	0.24	12.38
<b>Resource interdependency</b>	Inputs brought into the incubator by each participant are valuable for each other	3.38 (1.65)	0.79	0.38	10.54
	Participants provide vital inputs we find difficult to obtain elsewhere	2.79 (1.54)	0.93	0.14	13.72
	Participants share a level of mutual dependence to achieve stronger competitive performance	2.63 (1.44)	0.90	0.19	13.04
<b>Network-based learning</b>	Operating in this incubator has provided a fast way of learning	2.91 (1.65)	0.94	0.11	14.17
	Our rate of learning is far ahead of where we would be had we 'gone it alone'	2.92 (1.72)	0.91	0.16	13.45
	The quality of knowledge and experiences gained are superior than had we 'gone it alone'	3.01 (1.71)	0.94	0.12	14.07
	Exchange of information and experiences takes place frequently and informally among the members of the center/park	2.70 (1.55)	0.60	0.64	7.40
	We have learned a great deal from the members of the business network	2.85 (1.65)	0.63	0.60	7.86
<b>Absorptive capacity</b>	Lessons learned from past product/project/ business decisions are thoroughly analyzed and shared with others in the business	3.51 (1.80)	0.86	0.26	11.43
	Meetings are often conducted to identify what can be learned and improved upon from activities and events	3.78 (1.81)	0.86	0.26	11.45
	Our business applies the lessons learned from past products/projects/decisions to future products/projects/decisions	4.98 (1.62)	0.64	0.59	7.64
	There is a good deal of conversation within the business that keeps alive the lessons learned from history	4.06 (1.76)	0.62	0.62	7.35
<b>Network intensity</b>	We try to bring many participants into our business processes and projects early	3.19 (1.70)	0.69	0.53	8.59
	We find it necessary to involve ourselves in a business network	3.52 (1.94)	0.71	0.49	9.00
	We regularly attempt to obtain assistance from network businesses available through the center/park	2.98 (1.73)	0.90	0.20	12.69
	We regularly participate in networks available through the center/park	3.11 (1.79)	0.85	0.28	11.70
<b>External embeddedness</b>	Relationships with business network members are important to the growth of our business	2.90 (1.71)	0.94	0.12	14.01
	Relationships with business network members has led to changes in how we conduct our business	2.88 (1.63)	0.88	0.23	12.60
	Our relationships with network members are important to our business activities	2.95 (1.71)	0.97	0.06	14.89

<b>Local embeddedness</b>	Relationships with center/park businesses are important to our ability to compete	2.50 (1.44)	0.90	0.19	13.05
	Relationships with center/park businesses have been important in helping our business to grow	2.58 (1.54)	0.92	0.15	13.61
	Relationships with center/park businesses has led to changes in how we conduct our business	2.55 (1.48)	0.90	0.18	13.18
	Our relationships with center/park businesses are important to our business activities	2.69 (1.64)	0.93	0.13	13.94
<b>Market performance</b>	Relative to competing products, those of our business have been more successful in terms of sales	4.29 (1.44)	0.95	0.09	14.22
	Relative to competing products, those of our business have been more successful in terms of achieving and establishing market share	4.35 (1.45)	0.97	0.07	14.54
	The business has experienced rapid growth	4.62 (1.60)	0.52	0.73	6.21
<b>Response performance</b>	Make fast responses to customer wants concerning changes in products and services	5.62 (1.13)	0.69	0.52	8.80
	Adapt your business adequately to changes in the business environment	5.33 (1.07)	0.94	0.12	13.81
	React to market and environmental changes in a quick and satisfactory way	5.33 (1.07)	0.92	0.16	13.28
	Respond promptly to new technological changes	5.62 (1.18)	0.61	0.63	7.45
	Respond promptly to new market threats	5.21 (1.07)	0.70	0.51	8.91



**Table 2. Correlation matrix and descriptive statistics**

	Descriptive statistics														
	X1	X2	X3	X4	X5	X6	X7	X8	X9	X10	X11	X12	X13	X14	X15
X1. Shared norms	0.90 <sup>a</sup>														
X2. Resource interdependency	0.56**	0.88													
X3. Network-based Learning	0.54**	0.81**	0.82												
X4. Absorptive capacity	0.27**	0.35**	0.38**	0.75											
X5. Network intensity	0.50**	0.67**	0.76**	0.40**	0.79										
X6. External embeddedness	0.31**	0.55**	0.68**	0.31**	0.68**	0.93									
X7. Local embeddedness	0.46**	0.73**	0.75**	0.37**	0.67**	0.71**	0.92								
X8. Market performance	0.03	-0.10	-0.16*	0.07	-0.17*	0.10	0.01	0.84							
X9. Response performance	0.12	-0.04	-0.07	-0.19**	-0.05	0.02	0.00	0.48**	0.78						
X10. Ranked facility type	-0.05	-0.09	-0.07	-0.09	-0.08	-0.06	-0.06	0.02	-0.10	n/a					
X11. Size (log)	-0.14*	-0.28**	-0.27**	-0.04	-0.18*	-0.16*	-0.18*	0.30**	0.05	0.29**	n/a				
X12. Age (log)	-0.14*	-0.23**	-0.22**	-0.05	-0.21**	-0.13	-0.12	0.10	-0.14*	0.18**	0.44**	n/a			
X13. Incubator size (log)	0.15*	0.04	-0.05	-0.01	0.00	-0.02	-0.01	0.03	0.04	0.01	-0.02	0.10	n/a		
X14. Net profit	-0.05	-0.06	-0.03	0.10	-0.01	0.01	-0.02	0.12	0.01	-0.05	-0.01	0.14	0.02	n/a	
X15 Profit growth	0.05	0.08	0.06	0.05	0.04	0.01	0.08	0.14	-0.08	-0.01	-0.11	-0.04	-0.02	-0.02	n/a
Mean	3.94	2.94	2.92	4.09	3.20	2.91	2.58	4.41	5.42	3.82	0.87	0.41	1.35	-0.08 <sup>b</sup>	-28.52
S.D.	1.48	1.41	1.43	1.39	1.49	1.58	1.42	1.31	0.89	1.00	0.51	0.40	0.33	0.67 <sup>b</sup>	335.00
CR	0.95	0.91	0.91	0.84	0.87	0.95	0.95	0.87	0.89	n/a	n/a	n/a	n/a	n/a	n/a
AVE	0.81	0.77	0.67	0.57	0.63	0.86	0.84	0.70	0.61	n/a	n/a	n/a	n/a	n/a	n/a

\*\* Significant at 0.01 level (2-tailed).

\* Significant at 0.05 level (2-tailed).

<sup>a</sup> Coefficients on the diagonal are square roots of the average variance extracted of each construct.

<sup>b</sup> GBP millions.

n/a Not applicable as single item constructs.

CR: Composite reliability.

AVE: Average variance extracted.

**Table 3. Model fit statistics**

Model	$\chi^2$	df	$\chi^2/df$	RMSEA	CFI	IFI	NNFI	$\Delta\chi^2/df$	AIC <sup>1</sup>
CFA	1158.46	680	1.70	0.07	0.95	0.95	0.94		
CFA-CMV	4036.16	779	5.18	0.18	0.79	0.79	0.78		
SEM 1 <sup>a</sup> restricted	886.48	371	2.39	0.08	0.97	0.97	0.96	17.60(1)*	144.48
SEM 1 <sup>a</sup> unrestricted	868.88	370	2.35	0.08	0.97	0.97	0.96		128.88
SEM 2 <sup>b</sup> restricted	199.19	115	1.73	0.06	0.95	0.95	0.94	3.94(1)*	-30.81
SEM 2 <sup>b</sup> unrestricted	195.25	114	1.71	0.06	0.95	0.95	0.94		-32.75
SEM 3 <sup>c</sup> restricted	229.88	150	1.53	0.05	0.96	0.96	0.95	4.21(1)*	-70.12
SEM 3 <sup>c</sup> unrestricted	225.67	149	1.51	0.05	0.96	0.96	0.95		-72.33
SEM 4 <sup>d</sup> restricted	105.26	58	1.81	0.08	0.94	0.94	0.92	0.22(1)	-10.74
SEM 4 <sup>d</sup> unrestricted	105.04	57	1.84	0.08	0.95	0.94	0.92		-8.96
SEM 5 <sup>e</sup> restricted	119.92	58	2.07	0.09	0.93	0.93	0.90	0.01(1)	3.92
SEM 5 <sup>e</sup> unrestricted	119.91	57	2.10	0.09	0.93	0.93	0.90		5.91

<sup>a</sup> DV: Absorptive Capacity; Network-based Learning

<sup>b</sup> DV: Absorptive Capacity; Market Performance

<sup>c</sup> DV: Absorptive Capacity; Response Performance

<sup>d</sup> DV: Absorptive Capacity; Net profit after tax (standardized)

<sup>e</sup> DV: Absorptive Capacity; Profit Growth (as % and then standardized)

<sup>1</sup> Akaike's Information Criterion =  $\chi^2 - 2df$ . Criterion used for selecting the best model among alternatives. The model yielding the lower value of AIC is superior.

\* Decrease in  $\chi^2$  and df between the restricted and unrestricted model is significant at  $p \leq 0.05$ . Unrestricted model is therefore superior.

**Table 4. Hypothesis testing results**

Variables	Dependent variables							
	Standardized path coefficient ( <i>t</i> -value)							
	<b>SEM model 1</b>							
	<b>Absorptive capacity</b>	<b>Network-based learning</b>						
Resource interdependency		0.56 (5.88**)						
Network intensity	0.47 (5.77**)	0.30 (3.08**)						
Shared norms		-0.01 (-0.15)						
Absorptive capacity		-0.05 (-1.03)						
<b>Moderators</b>								
Network intensity x absorptive capacity		-0.12 (-2.83**)						
<b>Controls</b>								
External embeddedness		0.07 (0.94)						
Local embeddedness		0.02 (0.28)						
Ranked facility type		0.02 (0.40)						
Incubator size (log)		0.17 (2.40**)						
<i>Squared multiple correlations (structural equations)</i>	0.22	0.78						
	<b>SEM model 2</b>	<b>SEM model 3</b>	<b>SEM model 4</b>	<b>SEM model 5</b>				
	<b>Absorptive capacity</b>	<b>Market performance</b>	<b>Absorptive capacity</b>	<b>Response performance</b>	<b>Absorptive capacity</b>	<b>Net profit (after tax)</b>	<b>Absorptive capacity</b>	<b>Profit growth</b>
Network-based learning (NBL)	0.38 (4.62**)	-0.10 (-0.80)	0.37 (4.63**)	-0.33 (-2.96**)	0.30 (3.19**)	0.44 (0.14)	0.29 (3.04**)	0.14 (0.85)
Absorptive capacity		0.18 (2.13*)		0.35 (4.02**)		0.16 (1.41†)		0.13 (1.28†)
<b>Moderators</b>								
NBL x absorptive capacity		0.20 (2.14*)		0.21 (2.58**)		0.04 (0.19)		0.05 (0.45)
<b>Controls</b>								
Firm Size (log)		0.09 (2.33**)		-0.67 (-1.97*)		0.17 (2.48**)		0.59 (1.17)
Firm Age (log)		0.74 (2.39**)		0.01 (0.06)		0.14 (1.09)		0.20 (0.67)
<i>Squared multiple correlations</i>	0.14	0.20	0.14	0.15	0.09	0.07	0.08	0.02

---

*(structural equations)*

***Sobel mediation tests (mediator:  
absorptive capacity)***

Z-value	1.97*	3.04**	1.44†	1.29†
Effect ratio	0.68	0.40	0.12	0.31

---

\*\* Significant at 0.01 level (critical  $t$ -value = 2.326).

\* Significant at 0.05 level (critical  $t$ -value = 1.645).

† Significant at 0.10 level (critical  $t$ -value = 1.282).

### Appendix. Sobel test results

	a	SE <sub>a</sub>	b	SE <sub>b</sub>	Z	c	Effect ratio
Market performance	0.38	0.081	0.18	0.083	1.97*	0.10	0.68
Response performance	0.37	0.080	0.36	0.088	3.04**	0.33	0.40
Net profit	0.30	0.094	0.16	0.099	1.44†	0.39	0.12
Profit growth	0.29	0.094	0.14	0.099	1.29†	0.13	0.31

a Unstandardized path coefficient from independent variable to the mediator variable.

SE<sub>a</sub> Standard error of the relationship between the independent variable and the mediator variable.

b Unstandardized path coefficient from the mediator variable to the dependent variable.

SE<sub>b</sub> Standard error of the relationship between the mediator variable and the dependent variable.

Z Sobel test statistic:  $Z = ab/\sqrt{(a^2SE_b^2) + (b^2SE_a^2)}$

c Unstandardized path coefficient from independent variable to the dependent variable.

Effect Ratio =  $ab/c$

\*\* Significant at 0.01 level (critical Z-value = 2.326).

\* Significant at 0.05 level (critical Z-value = 1.645).

† Significant at 0.10 level (critical Z-value = 1.282).