

LOUGHBOROUGH
UNIVERSITY OF TECHNOLOGY
LIBRARY

AUTHOR/FILING TITLE

SLADE, A.P.

ACCESSION/COPY NO.

040101675

VOL. NO.

CLASS MARK

~~date due :-~~

~~23 JUN 1998~~

~~LOAN 3 WKS. + 3
UNLESS RECALLED~~

~~PT98586/87~~

LOAN COPY

0401016757



**MECHATRONICS APPLIED TO
SCALE MODEL DECORATION**

by

Alan Peter Slade

**A Masters Thesis submitted in partial
fulfilment of the award of**

Master of Philosophy

of Loughborough University of Technology

**Department of Mechanical Engineering
Loughborough University of Technology**

September 1993

© Alan Peter Slade, 1993

Loughborough University of Technology Library	
Date	Mar 95
Class	
Acc. No.	040101675

V891157X

to
Carol, my wife
Adam and Emily, my children
for all the long nights that I
have been slaving over this keyboard.

ACKNOWLEDGEMENTS.

I wish to thank Professor Jim Hewit for giving me the opportunity to express my ideas on Robotics and Mechatronics. He has encouraged me, and his guidance has enabled me to write this thesis on a work close to my heart. He has always had time to listen to me and discuss ideas, however wild or esoteric, for this and other possible research and I feel that a lasting friendship has developed because of this.

I am also indebted to Luis Trabasso from the Instituto Tecnológico de Aeronáutica, São Paulo, Brazil for his encouragement of me to write up my work whilst he was at Loughborough as a Research Student. We also wrote numerous papers and articles together and it was often decided on the toss of a coin who would go where to present them. We shared many things in common including a love of motor sport, and apparently I am also responsible for reviving a forgotten hobby of his.

Thanks also go to Dr. Cezary Zielinski, from the Warsaw University of Technology, for his suggestions and ideas and also TORBOL, the robot programming language he has developed. All I have to do now is learn Polish to understand it!

This project could not have been completed without the help of Barry Ellis who made a lot of the mechanical components. We would discuss an idea and sketch out possible solutions and Barry would then go away and produce just what was required. Thank you very much indeed Barry. I wish also to thank Ken Topley and Vince Scothern for the photographic work.

I am grateful to the personnel at Hornby Hobbies Limited for their assistance and help, especially to Keith Tyler and Derek Letley on the production side and Mike Walters in the Design Office.

To Steve, who has spent many hours printing this for me, I say a heartfelt thanks, and sorry for all the hassle.

Finally, to my wife Carol, thank you for your support, love and understanding whilst I have been working on this.

SUMMARY

The European toy industry is very heavily dependent on manual labour and therefore vulnerable to Far Eastern competitors, who have the advantage of lower labour costs. Automation is Europe's best hope of beating off this oriental challenge.

The aim of the project described within this thesis is to investigate the replacement of a traditionally manual series of operations by flexible automation to provide the basis for higher productivity and a greater degree of responsiveness to product change, leading to Just In Time Manufacture with reduced Work In Progress, while still retaining the high quality traditionally associated with the product.

This thesis presents one of the first working attempts to this end, represented by a proof-of-concept cell designed and commissioned for investigating the many problems and possibilities associated with the decoration of scale models of cars and trains. The cell was designed using the Mechatronics approach which means that the various mechanical, electrical and electronic and computing possibilities have been taken into account from the start of the design stage.

The proof-of-concept cell consists of five stations which provide the necessary means of loading the models in the cell, identifying the models and their orientation, decorating the models, inspecting the decorated models and finally palletising them for assembly.

The industrial partners for the project were Hornby Hobbies Limited, J-L Automation and Stäubli Unimation. Because this project centres around the present decoration operations at Hornby Hobbies Limited, which is heavily dependant on pad printing, an overview of pad printing is included. This will give the reader a background to the problems faced during the project.

Before describing the proof-of-concept cell and its hardware and software components, the present factory based method and the constraints put on the project by Hornby Hobbies Limited are explained so that the reasons for choices within the cell will be more readily understood. A brief history of Scalextric is also included so that the reader may also

understand some of the historical problems associated with the product.

The result of this mechatronic approach are two fold: a) the efficiency of the cell is improved because the individual parts are working at optimal efficiency b) the cell has a greater degree of flexibility because of the re-programming facilities embedded in each of its component parts.

This Mechatronic investigation has led to new concepts for pad printing and assembly operations and these are described in detail in the conclusions.

CONTENTS

CHAPTER 1: INTRODUCTION TO THE PROJECT	1
1.1 SUMMARY	2
1.2 THE PRESENT FACTORY OPERATION	2
1.2.1 Spray Painting	3
1.2.2 Lining Out	4
1.2.3 Decoration	5
1.3 CONSTRAINTS IMPOSED ON THE PROJECT	7
1.4 PAD PRINTING	8
1.4.1 Origins of pad printing	8
1.4.2 Pad printing today	9
1.4.3 The Pad Printing Process	9
1.4.4 Pad Printing elements	10
1.4.4.1 Printing Plates	10
1.4.4.2 Pads	11
1.4.4.3 Inks	12
1.4.5 Applications	12
1.5 DEVELOPMENTS OF THE PAD PRINTING MACHINE	13
1.5.1 Current pad printing machines	13
1.5.2 Semi-sealed Systems	13
1.5.3 Closed Ink Systems	14
1.5.4 Fully Automated Systems	15

1.6	THE NEED FOR DECORATION	16
1.7	AN HISTORY OF SCALEXTRIC	18
1.7.1	Future Plans	21
CHAPTER 2:	CONFIGURING THE CELL	22
2.1	SUMMARY	23
2.2	THE FORESEEN PROBLEMS	23
2.2.1	Transporting the bodysHELLS	23
2.2.2	Handling the bodysHELLS	24
2.2.3	Identifying the bodysHELLS	26
2.2.4	Decorating the models	28
2.2.5	Inspecting the bodysHELLS	30
2.3	THE UNFORESEEN PROBLEMS	30
2.3.1	Conveying the models and lighting arrangements	30
2.3.2	Parallax error	33
2.3.3	Repositioning device	35
2.3.4	Accurate location at the printing machine and inspection station	35
2.3.4.1	Fitment to the worktable	36
2.3.4.2	Adjustment of the angle for printing	36
2.3.4.3	Accurate placement	37
2.3.4.4	Interchangeability	38
2.3.4.5	Ease of use	38
2.4	HAND OVER FROM INSPECTION TO PACKING	39

2.4.1	Co-operating robots	39
2.5	STACKING AND REMOVAL OF THE PALLETS	39
2.6	CYCLE TIME OF THE DECORATING CELL	40
2.6.1	Improvements to the decoration cell cycle time	41
CHAPTER 3:	THE COMPONENT PARTS OF THE CELL.	43
3.1	SUMMARY	44
3.2	OVERVIEW OF THE PROOF-OF-CONCEPT CELL	44
3.2.1	The loading station	45
3.2.1.1	Mechanical adjustments	48
3.2.2	The identification station	49
3.2.2.1	Mechanical adjustment	50
3.2.2.2	Electrical adjustment	52
3.2.3	Information required from the identification station	53
3.2.3.1	Re-positioning device	55
3.2.4	Decoration station	56
3.2.4.1	Tool changer	56
3.2.4.2	Tampo print machine	57
3.2.5	The inspection station	58
3.2.6	The unloading station	59
3.2.6.1	The matrix/pallet concept	60
3.2.6.2	The 'H' shaped suction end-effector	61
3.3	THE TAMPO PRINTING MACHINE	63
3.3.1	Setting up	64
3.4	INTERFACING BETWEEN COMPONENTS	66

3.4.1	Loading station	66
3.4.2	Identification station	66
3.4.3	Decorating station	67
3.4.4	Inspection station	67
3.4.5	Unloading station	68
CHAPTER 4: THE SOFTWARE USED IN THE CELL		69
4.1	SUMMARY	70
4.2	SOFTWARE SYNTHESIS	71
4.2.1	Loading station	71
4.2.2	Identification station	73
4.2.3	Decoration station	74
4.2.4	Inspection station	76
4.2.5	Unloading station	77
4.3	THE JOYCE-LOEBL MAGISCAN VISION SYSTEM	79
4.3.1	Training process	81
4.3.2	Flowchart and data file output	82
4.3.3	Off-line assessment	83
4.3.4	Vision system PUMA robot calibration	83
4.4	GENERATION OF THE INSPECTION DATABASE	85
4.5	THE ON-LINE PROGRAMME - OWL	90
CHAPTER 5: THE ELECTRONIC AND ELECTRICAL DESIGN OF THE CELL		92

5.1	SUMMARY	93
5.2	THE RS-232C SERIAL LINK	93
5.3	PROGRAMMABLE LOGIC CONTROLLER	96
5.3.1	Control of the workpiece carriers around the conveyor system	97
5.4	ELECTRONIC SYNTHESIS OF THE FIVE STATIONS	99
5.4.1	Loading station	99
5.4.1.1	Sequential control of the loading mechanism	99
5.4.1.2	Monitoring the bodysHELLS	101
5.4.2	Identification station	103
5.4.2.1	Control of the station	104
5.4.2.2	CCD camera connection to the vision system	104
5.4.3	Decorating station	106
5.4.4	Inspection station	109
5.4.4.1	Camera connections	109
5.4.4.2	Interaction with the PUMA robot	109
5.4.4.3	Communication with the unloading station	110
5.5	UNLOADING STATION	110
5.5.1	Interaction between the PUMA and RTX robots	110
5.5.2	Control of the suction cups	110
CHAPTER 6:	THE OPERATION OF THE CELL	112
6.1	SUMMARY	113
6.2	OVERVIEW OF THE OPERATION OF THE CELL	113

6.2.1	Work cycle	113
6.3	OPERATION OF THE CELL	115
6.3.1	Start up procedure	115
6.3.2	Operator interface	118
6.4	CONTROL OF THE CELL	119
6.4.1	Recovery strategies	119
6.5	FLEXIBILITY OF THE CELL	123
6.5.1	Modular decoration station	124
CHAPTER 7:	AREAS FOR FURTHER RESEARCH	
	BALANCED CONFIGURATION DESIGN	
	APPRIMA - THE NEXT GENERATION OF	
	PAD PRINTING MACHINE	125
7.1	SUMMARY	126
7.2	POSSIBLE IMPROVEMENTS TO	
	THE PRINTING METHOD	126
7.2.1	The PAINTER approach	126
7.2.2	The peg-in-a-hole approach	128
7.2.3	The revised peg-in-a-hole approach	130
7.2.4	Improvements to the revised peg-in-a-hole approach	132
7.2.5	The matrix-on-belt approach	132
7.2.6	Other modifications to the printing machine	135
7.3	OTHER PRINTING TECHNOLOGIES	135

7.3.1	Ink Jet Printing	135
7.3.2	Transfer printing	136
7.4	MECHATRONIC TOOL CHANGER	136
7.4.1	The locking and unlocking principle	137
7.4.2	Pneumatic and electrical ports	138
7.5	SINGLE AXIS FORCE-ACCELERATION ADAPTOR	138
7.6	BALANCED CONFIGURATION DESIGN	140
7.7	ARTIFICIAL INTELLIGENCE APPLICATIONS	141
7.7.1	Start up of the decoration cell	142
7.7.2	assesment of the training process	142
7.7.3	Recovery strategies	143
7.8	APPRIMA - THE NEXT GENERATION OF PAD PRINTING MACHINE	144
CHAPTER 8:	CONCLUSION	148
8.1	SUMMARY	149
8.2	CONTRIBUTION TO SCALE MODEL DECORATION AND PAD PRINTING	149
8.3	CONTRIBUTION TO MECHATRONICS	151

LIST OF FIGURES

1.1	Using a spray mask	3
1.2	Lining out	4
1.3	The present factory operation	5
1.4	Decorating three models at once	6
1.5	The principle of Pad Printing	9
1.6	Pad shapes	11
1.7	Pad Printing Machine	13
1.8	Semi-sealed ink system	14
1.9	Closed Ink System	14
1.10	Automated print system	15
1.11	The improvement in decoration quality	17
1.12	The importance of decoration in the scale model industry	17
2.1	Print matrix used in the decoration operation	25
2.2	The venturi principle	26
2.3	Examples of complex logos	27
2.4	The various orientations adopted by a bodyshell during decoration	29
2.5	Sidelighting at the identification station	33
2.6a)	without sidelighting	34
2.6b)	with sidelighting	34
2.7	The optical Illusion phenomenon caused by lack of depth information	35
2.8	Using a 2-D representation of the bodyshells	35
2.9	The sensors around the vacuum cup	36
2.10	The repositioning device	37
2.11	The arrangement of the pegs and holes	38
2.12	Co-operating robots	40
2.13	Possible solution to the conveyor approach	42

3.1	The Proof-of-Concept Cell	44
3.2	Principle of operation of the loading station	45
3.3	Side view of the loading station	48
3.4	Front view of the loading station showing the adjustment slots for the chute.	49
3.5	Light distribution through the perspex block	50
3.6	Apparatus used for determining the total reflection angle of the perspex block	51
3.7	Perspex block lit by a 5 milliwatt Helium Neon laser at 0° (a) and 6° (b)	51
3.8	Angular adjustment of the side-lighting mechanism	52
3.9	The principle of operation of the re-positioning device	54
3.10	The inclination angles of the re-positioning device	55
3.11	The original tool changer	56
3.12	The Mechatronic tool changer	57
3.13	The inspection station	58
3.14	The component parts of a pallet	60
3.15	An assembled pallet	61
3.16	The 'H' section end-effector used on the RTX robot	62
3.17	The two actions performed by the 'H' shaped end-effector	63
3.18	Fitting the cliché onto the die-plate	64
3.19	The component parts of a Tampo Printing Machine	65
4.1	PLC input/output allotment at the loading station	71
4.2	Part of the PLC mnemonic code showing the routine for the loading station	72
4.3	Structure of the off-line programme of the identification station	74
4.4	The VAL II code of TUCANO	75
4.5	The VAL II code of PRINT.TAMPO	75
4.6	The PUFFIN source code	78
4.7	An example of the palletising code	79
4.8	Typical structure of a Pascal programme using MAGISCAN units	81
4.9	Typical data file structure	82
4.10	Flowchart of the training process	84
4.11	The calibration marks on the workpiece carriers	85

4.12	Typical image at the inspection station	86
4.13	Binary image of the bonnet highlighting light features	87
4.14	Computer screen of bonnet white features selection	88
4.15	Typical data structure of the inspection database	89
4.16	Flowchart of the interaction between OWL and EAGLE	91
5.1	Typical wiring connections between the PLC and a proximity switch and stop gate	97
5.2	Schematic of the PLC connections in the proof-of-concept cell	98
5.3	Wiring of the PLC for controlling the loading station	100
5.4	Sequential control of the loading station	101
5.5	The sensor fitted to the end of cylinder A	102
5.6	Principle of operation of the reflective opto-switch	102
5.7	Circuit used to boost the sensitivity of the reflective opto-switch	103
5.8	Wiring at the identification station	104
5.9	Sequential control of the identification station	105
5.10	The CCD camera connections and control settings	106
5.11	The wiring connections between the PUMA controller and the printing machine	108
5.12	Wiring of the unloading station	111
6.1	Schematic layout of the proof-of-concept-cell	114
6.2	PUMA-vision system RS-232 check	117
6.3	Recovery action at the loading station	121
6.4	Recovery action at the decoration station	122
7.1	Schematic of the PAINTER approach	127
7.2	Schematic of the peg-in-a-hole approach	129
7.3	The revised peg-in-a-hole approach	130
7.4	Modified peg-in-a-hole base unit	131
7.5	The indexing matrix principle	132
7.6	The principle of operation of the matrix-on-belt approach	133
7.7	The model of the prototype matrix-on-belt approach	134
7.8	The Mechatronic tool changer	136

7.9	The passive and active locking mechanisms of the mechatronic tool changer	137
7.10	The Force/Acceleration adaptor undergoing trials	138
7.11	The graphs of force and acceleration for the assembly of an axle into a chassis	139
7.12	Single axis force-acceleration adaptor	139
7:13	Balanced Configuration Design experimental unit	141
7.14	Example of a consultation session by the operator during the start up of the decoration cell	142
7.15	A schematic of APPRIMA	146
8.1	The first Mechatronically decorated bodyshell	150

LIST OF TABLES

4.1	The various high level languages used in the proof-of-concept cell	70
5.1	The most popular pins implemented in an RS-232C serial link	95
5.2	The minimum configuration of an RS-232C serial link	95
5.3	The printing machine switches controlled by the PUMA controller	108
6.1	Air supply pressure to the component parts of the proof-of-concept cell	116
7.1	The comparison of the features incorporated in the different designs of pad printing machines	145

CHAPTER 1:
INTRODUCTION TO THE PROJECT.

1 SUMMARY.

The European toy industry is very heavily dependent on manual labour and therefore vulnerable to Far Eastern competitors, who have the advantage of lower labour costs. Automation is Europe's best hope of beating off the oriental challenge.

This project presents one of the first working attempts to this end, represented by a proof-of-concept cell designed and commissioned for investigating the many problems and possibilities associated with the decoration of scale models of cars and trains.

The aim of the project is to replace a traditionally manual series of operations by flexible automation to provide the base for higher productivity and a greater degree of responsiveness to product change, leading to Just In Time Manufacture with reduced Work In Progress, while still retaining the high quality traditionally associated with the product.

The co-operating industrial partner for the project is Hornby Hobbies Limited. Before describing the proof-of-concept cell, it would be instructional to the reader to briefly explain the present factory based method and the constraints put on the project by Hornby Hobbies Limited so that the reasons for choices within the cell will be more readily understood.

Because this project centres around the present decoration operations at Hornby Hobbies Limited, and in particular pad printing, an overview of pad printing is included. This will give the reader a background to the problems faced during the project.

The importance of decoration to the model industry is discussed in section 1.6.

To finish this opening chapter a brief history of Scalextric is also included, as it is felt this is also necessary to gain further background to the project.

1.2 THE PRESENT FACTORY OPERATION.

The models (cars or trains) are moulded in the factory and are then manually inspected for 'flash' or flaws in the moulding and the passed bodyshells are then wrapped in tissue paper and

boxed for the first time. Depending upon the particular model there are three possible decoration methods that can be applied to it.

- spray painting
- lining out
- pad printing.

1.2.1 Spray Painting.

Spray painting, also known as large area spray, is chosen if the bodyshell has a relatively large



Figure 1.1: Using a spray mask

well defined area of colour to be added. This has two sub divisions; either first they go into the automatic spray booth for an all over spray to obtain the authentic colour (most of the locomotive models go through this step) or they are fitted into a spray mask and air brushed to colour (Figure 1.1).

The main problem with this second technique is the cleaning of the spray mask. The operator has to strip and thoroughly clean the mask unit frequently to avoid paint runs inside the mask and hence onto the model. This obviously slows production down considerably, to no more than 15 - 20 models an hour.

Spray painting is recognised as the area where the greatest cost savings can be made as possibly 80% of the paint is wasted in spray mist into the filters and overspray onto the mask. It is here that some other printing technology, such as ink jet printing would have the largest impact, given the present limitations of the technology.

1.2.2 Lining Out.



Figure 1.2: Lining Out

A particularly expensive operation is that of applying thin lines to the bodysells of locomotives and other rolling stock. This is necessary to pick out the hand rails, roof edges, guttering and so on. This can only be done manually at present (although a robotic method has been developed for this technique) since the parts are either recessed, in the case of the handrails, or proud in the case of the roof edges.

The method used is for an operator to ink these lines in using a 'claw' or mapping pen (Figure 1.2). The open nature of the pen and the fact that very little ink can be carried in the pen means that it is constantly having to be cleaned and filled. There is a high degree of concentration and skill required even though the job is in itself relatively simple, and there is a six month training period for these particular operatives. These factors combine to produce a low work throughput of around six to ten models an hour.

1.2.3 Decoration.

Decoration (Figure 1.3) is a particularly labour intensive operation requiring a large amount of skilful handling on the part of the operator to achieve a perfect finish. The particular model that trials are being conducted on, for example, has 19 operations and will be presented to 7

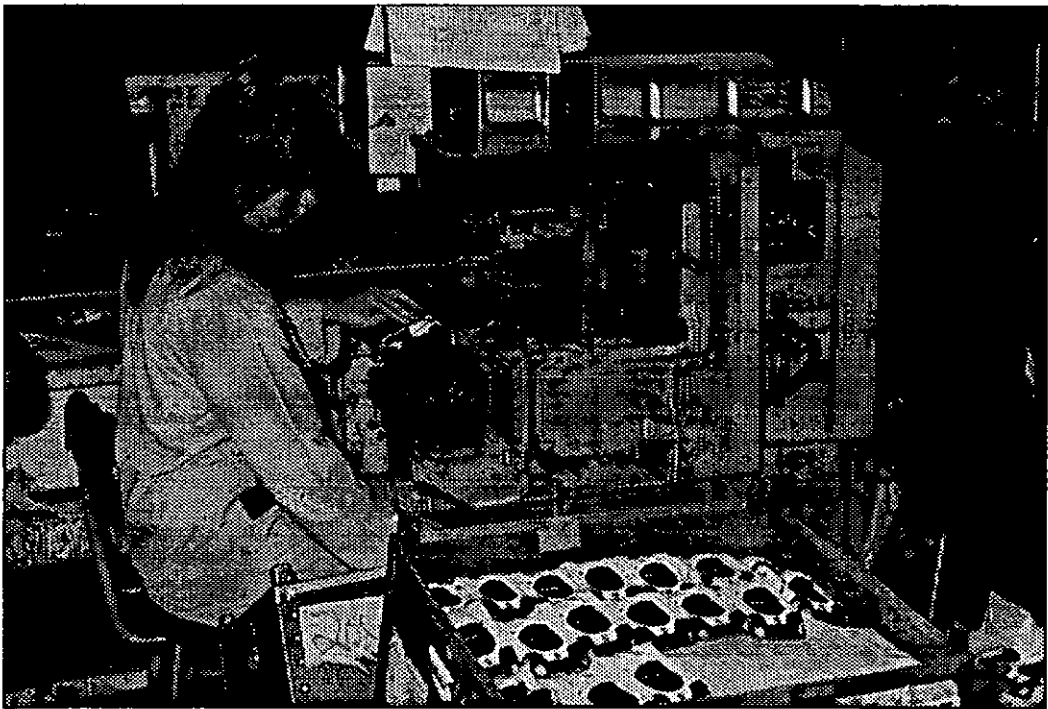

Figure 1.3: The present factory operation.

tampo print machines, all set up for 2 colour and some 3 colour printing. This is an average number of operations, and as a flow-line operation is not utilised it takes around two to three weeks to finish all the decorations on any particular model.

After each decoration cycle the models are manually inspected and then wrapped in tissue paper and boxed and stored ready for the next operation which could be further decoration. It takes typically two to three hours to set up each tampo print machine for each decoration/colour change.

It can be seen that this method of operation has the following distinct stages (Figure 1.4):

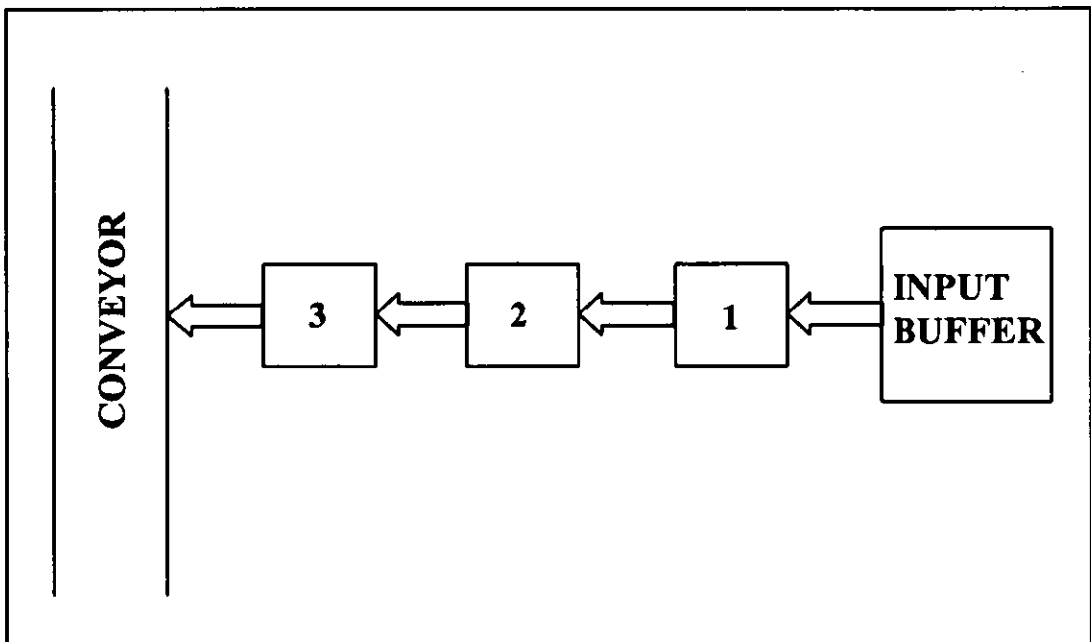

Figure 1.4: Decorating three models at once

- a) Each model must be selected from a box and placed at the first printing position to have the first decoration printed
- b) It must then be removed and placed at the second to have the second decoration added
- c) This operation is then repeated for the third printing position
- d) Finally it is removed and placed onto a conveyor belt, where it is transferred to the inspection and re-packing station
- e) Even though a “wet-on-wet” printing process is utilised models are sometimes put in a ‘buffer’ between the first and second and the second and third printing positions.

1.3 CONSTRAINTS IMPOSED ON THE PROJECT.

At the start of the project certain conditions were laid down by the industrial partners regarding the proof-of-concept cell. These were that it should:

- a) fit into a 5 meter square floor area
- b) be able to fully decorate a model
- c) utilise the existing tampo print machines
- d) be able to handle all current and future models
- f) operate with the minimum of supervision
- e) be able to decorate trains as well as cars
- g) be capable of integration into any future automation.

It can be seen straight away that condition (c) is a severe limiting factor on the overall flexibility of the cell and that this directly affects, and in a way conflicts with, condition (b), in so much as six or seven machines are required to fully decorate a model. These two conditions have, in fact, have determined the whole strategy of the project.

Conditions (d) and (e) are not as bad as they might at first seem in that even though the model varies, the overall size for the various types of model is reasonably constant. Therefore a universal handling tool should be all that is necessary.

Condition (a) will allow for the greatest flexibility for positioning in a factory environment, although a seven machine set up will require far more floor space while (f) is understandable, why have large scale automation if you still need a large staff to look after it? Condition (g) is another hard condition to satisfy in that at present there is very little automation in the factory, and there is no clear indication as to what will happen in the future. In this case all that can be done is to provide some form of 'standard' input and output to the cell.

The standard input facility is taken to be a chute/conveyor system and palletisation is assumed as the output from it. This choice was fairly arbitrary but would seem to be reasonable in view of the overall aim of Hornby Hobbies to automate as much as possible. Chute/conveyor systems are in use in many industries as the means of moving differing sized objects around, and once orientation and position have been obtained by carrying out one operation (decoration) it

is best not to lose it before the next operation (assembly). In the case of Hornby Hobbies it would also save on tissue paper and boxes as well as the models would not need the constant wrapping and packing after each pass through the decoration cycle.

1.4 PAD PRINTING.

1.4.1 Origins of pad printing.

Pad printing is basically an offset gravure printing method. The ink is applied in excess over an engraved plate, a blade removes the excess, a soft rubber pad picks up the ink from the engraved plate and transfers it to the surface to be printed.

The origins of the pad printing process are to be found in the European watch industry two hundred years ago. The method was originally developed for use in the Swiss watch industry for decorating watch faces. In those days the watch faces were hand painted with ornate designs.

One of the artists involved had the idea of making a positive engraving of his dial design in a metal plate, filling it with ink, removing the excess and using a rubber pad to transfer it to the clock face.

The main advantage of this new process was that by using a finely engraved plate (or cliché), very fine detail could be achieved. The disadvantage was that the gelatine pad used had a very short life as it was subject to heat changes and attack by ink. Normally the pads had to be remoulded daily and kept cool overnight.

In Germany the industrialist Wilfried Philip saw the potential in other sectors of industry where complex surfaces and inaccessible print areas were constantly giving rise to problems. Although he greatly contributed to the automation of the process in general, his major contribution was the solution of the problems associated with the gelatine pad. He invented a new formula for the pad material based on a silicone rubber compound plasticised with silicone oils. In 1968 he founded Tampoprint which produced the first automatic pad printing machine for large scale industrial use.

1.4.2 Pad printing today.

The pad printing process presently competes successfully with other printing techniques such as screen printing, hot foil, offset printing and mask spraying in decorative applications especially on non-uniform and curved surfaces.

Today as much as 90% of the decoration in the interior of a car is applied by pad printing and it is still the principal printing technique used in the watch industry from where it had its origins. Pad printing can impress characters onto a completely assembled plastic keyboard at one stroke; it can print decorative designs directly onto compact discs; it can impart decorations on plastic beverage closures at fast assembly-line rates.

Pad printing can be applied to flat, cylindrical or odd shaped parts, using either one or more colours. In multiple colour printing, the wet-on-wet technique is used to build up the decoration between the different colour applications. These are claimed to be its main advantages when compared to the other printing processes.

1.4.3 The pad printing process.

The actual principle of printing has remained unchanged since the first machines i.e. transferring an image from the cliché to the product, however a detailed description of the process based on the actual machines is given below. Refer to Figure 1.5.

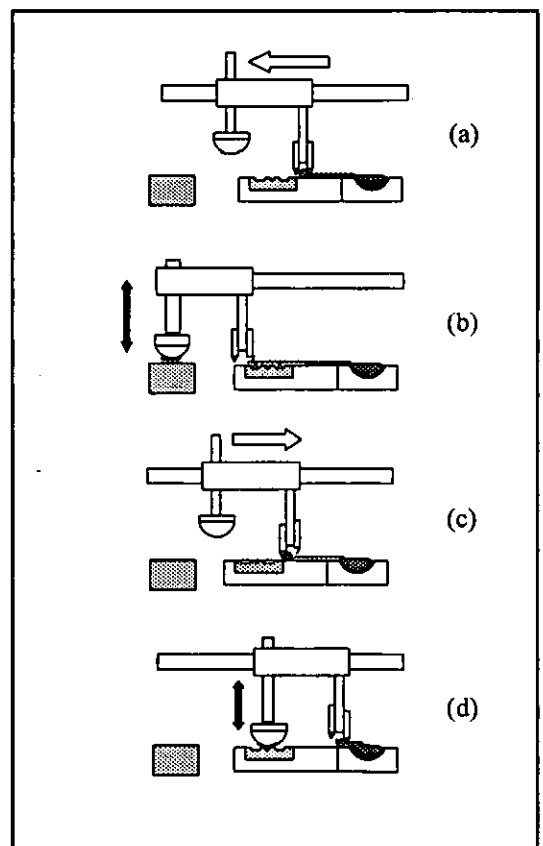

Figure 1.5: The principle of pad printing

(a) The spatula blade mechanism moves forward across the cliché drawing ink from the ink well with the doctor blade clear of the cliché and the pad, in the raised position, is moving forward at the same time. (b) The spatula is spreading ink over the cliché; the pad is now printing from the previous cycle onto the product. (c) The pad returns to the raised position and

the mechanism travels back to the start position with the doctor blade now in the down position, wiping the surplus ink from the cliché. Thus just the engraving is left with ink in it. The thinner evaporates from the engraving and the surface becomes tacky. **(d)** The pad descends onto the cliché and as it presses onto the engraving ink sticks to the pad. As the pad lifts, it takes not only the tacky, adhering film, but also the more fluid ink underneath.

(a) The pad moves away from the cliché and onto the product. On its way the thinner from the exposed surface of the ink on the bottom of the pad evaporates, and so this surface now becomes tacky. **(b)** The printing surface executes a rolling motion over the product, expelling the air between the pad and the object. As the pad is pressed down the film of ink sticks to the object and separates from the pad as it is raised. And so the cycle repeats.

1.4.4 Pad printing elements.

There are three main elements to a pad printing machine:

- printing plates
- printing pads
- inks.

1.4.4.1 Printing plates.

Printing plates are made from various materials including hardened steel, steel foil, plastic and copper. Steel plates are made from 0.4 to 1 centimetre thick hardened and ground or chrome coated steel. They are used for precision work and long runs, typically up to 10 million impressions. Although mechanically engraved steel plates are used they are usually engraved by photo-etching. The average etch depth is 0.02 to 0.04 millimetres.

Steel foils, which are prepared in a similar manner to hard steel plates, have a shorter lifespan of around 50,000 impressions.

Copper plates can be an inexpensive alternative for short runs. However, because copper is softer than steel, it requires a deeper etch and as a result, makes the ink harder to control in

printing. It dries more slowly, tends to blur and ultimately does not produce such clear or accurate images as steel plates.

Nylon or photopolymer plates are the best plates for short runs. These are produced from a metal backing plate coated with a photosensitive layer which polymerises under the action of light, and so becomes hard. The etching process is again similar to that for steel plates. Treated carefully, these plates can produce up to 20,000 impressions.

1.4.4.2 Pads.

The pads are manufactured from silicone rubber plasticised with silicone oils. They are made by pouring the formulated silicone compound into a mould and then left to cure. The cured pad is then mounted onto a plywood block. The pad shape depends upon the surface to be printed. Some of the several standard shapes are shown in Figure 1.6.

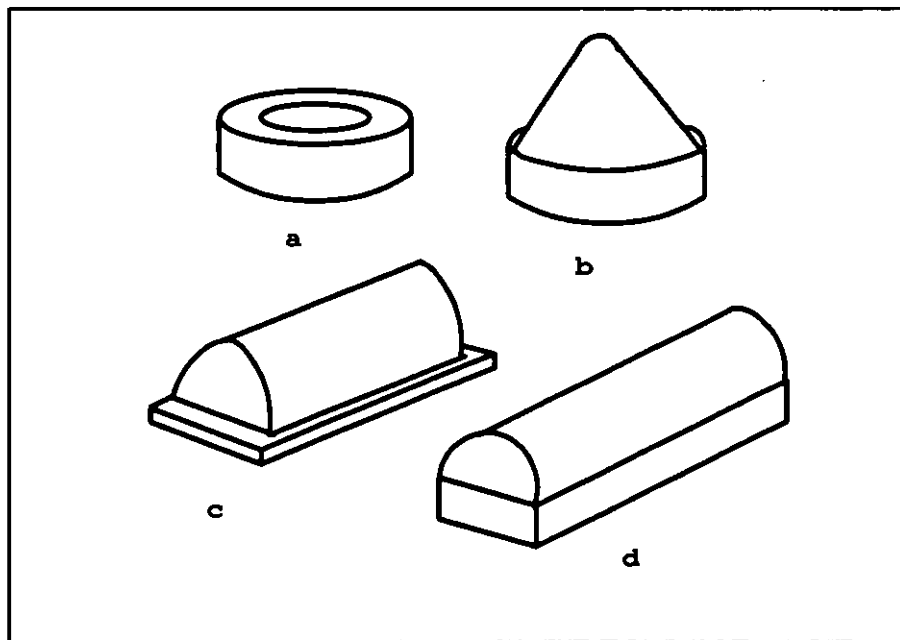

Figure 1.6: Pad shapes: a) doughnut, b) standard, c) wedge, d) ribbon.

Pad (a) is a doughnut pad used for printing dials which have a raised knob in the centre. Pad (b) is used for printing simple surfaces, achieving a good roll-off effect, minimising the possibility of air entrapment under the ink. Usually the pad is compressed during printing until the side

walls are almost vertical. For printing long narrow areas¹ pad (c) is the most appropriate, whilst pad (d) is used for printing the bottom of a slot.

The largest possible pad must be used in order to keep distortion to a minimum. Pads are available in four hardness levels and the hardest pad that can be used for a particular application should be selected, because harder pads have a better ink release and are more durable.

1.4.4.3 Inks.

The choice of the ink is governed by the requirements the ink has to meet. These can be abrasion resistance, solvent resistance, whether glossy or matt, weatherproofing and so on.

The viscosity of the ink is very important. If it is too viscous it might not be picked up by the pad from the cliché, if it is too fluid the cohesion might not be high enough and the ink may not be completely transferred from the pad. Because ink viscosity is so critical in the pad printing process, some ink manufacturers have developed simple viscosity meters that can be used when the printing machine is operating.

1.4.5 Applications.

The range of applications for pad printing is limited only by the size of the image. Because it can be used on irregular surfaces and in wet-on-wet operations pad printing is widely accepted for printing computer components and electrical appliances. Pad printing is also used for medical devices, automotive parts, glass frames and lenses, sporting goods, toys, watch and instrument dials, irregularly shaped containers, advertising specialities, cigarette lighters, pens and many other products.

1. Typically 5 x 20 centimetres

1.5 DEVELOPMENTS OF THE PAD PRINTING MACHINE.

1.5.1 *Current Pad Printing Machines.*

A large variety of pad printing machines are currently available, ranging from small hand operated models to huge hydraulically driven machines. The smallest printers normally have printing plates that are no more than five centimetres square. The largest machines have printing plates that measure 40 by 90 centimetres.

Pad printing machines can be set up for single or multi-colour printing and can incorporate various types of indexing tables, shuttle devices, linear or rotary conveyors.

Figure 1.7 shows a pad printing machine with microprocessor control, pre-programmed with 28 print options and a maximum print area of 30 by 10 centimetres. This is one of the machines that Hornby Hobbies are currently using for decoration.

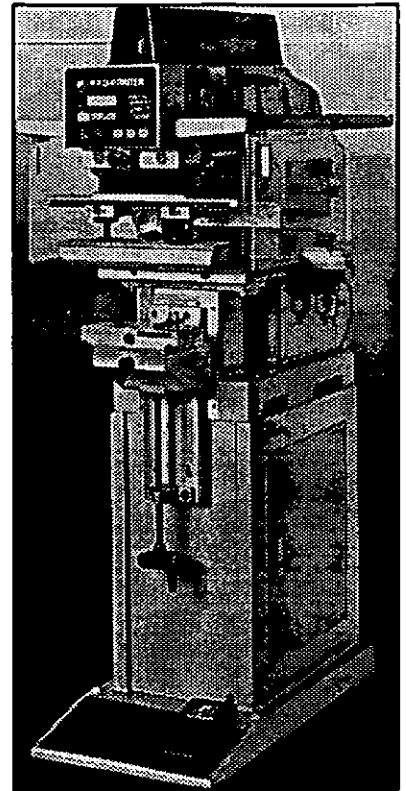

Figure 1.7: Pad printing machine.
(From a Kent Engineering Co. Ltd. brochure)

There have been many advances in tampo Hornby Hobbies first equipped their new factory in Margate in 1970. The open ink system has long been recognised as being wasteful and dangerous because of the fumes from the thinners. Extractor fans tend to increase the problems as not only do they remove the fumes they cause the ink to 'dry up' quicker by helping the evaporation of the thinners.

1.5.2 *Semi-sealed systems.*

Semi-sealed systems have been tried where the ink is kept in a deeper well and agitated by a series of rollers, and a roller used in place of the spatula blade to transfer the ink to the cliché from a slot in the top of the ink well (Figure 1.8). This is very similar to the letterpress printing technique. This method is not suitable for the multi colour "wet-on-wet" printing technique applied at Hornby Hobbies.

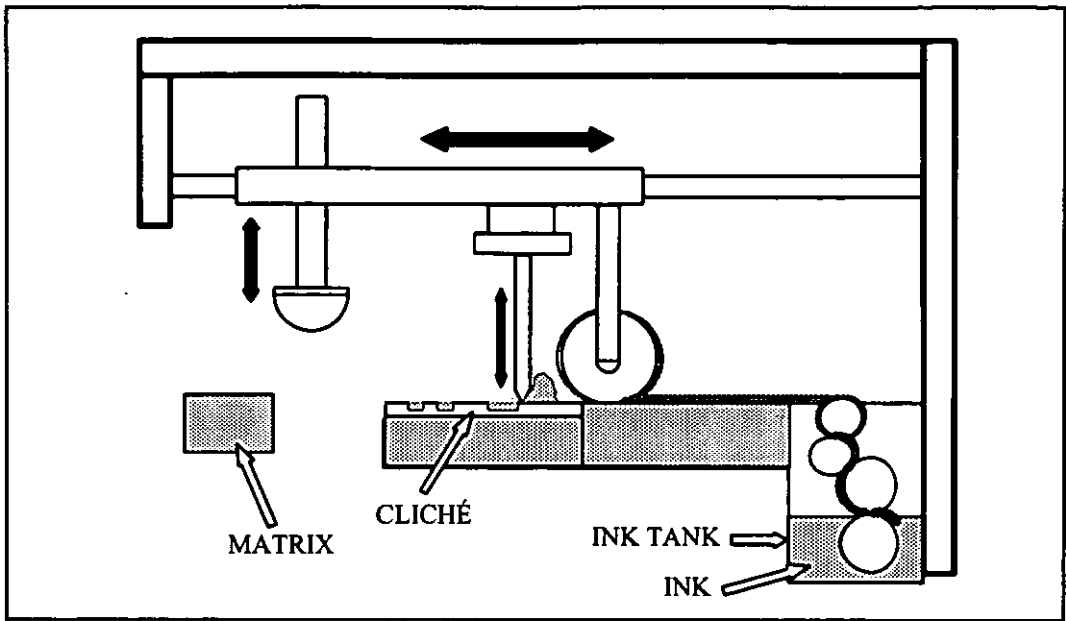

Figure 1.8: Semi-sealed ink system.

1.5.3 Closed Ink Systems.

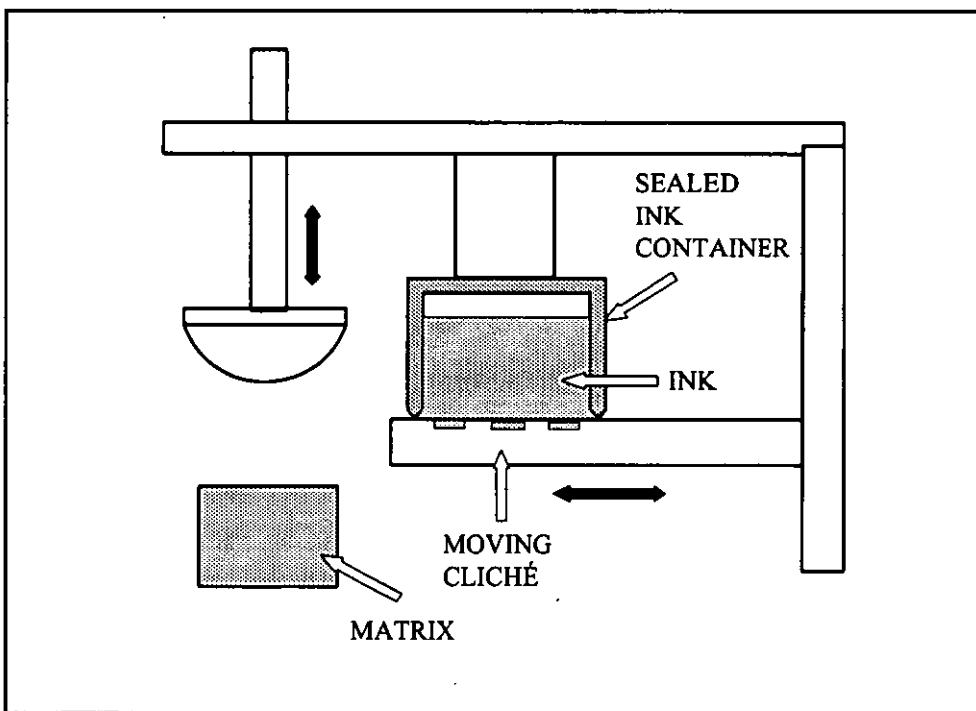

Figure 1.9: Sealed ink system

The biggest advance in Tampo printing came in 1984 with the introduction of the closed ink system. This consisted of a circular container kept in contact with a moving cliché (Figure 1.9). The claimed advantages of this were that there was no longer any doctor blade adjustment needed, as the blade was in constant contact with the cliché, and that the thinners could not evaporate as after the unit was assembled there was no contact with the surrounding atmosphere.

There were two unfortunate disadvantages though; the machines are expensive when compared to the previous open systems and the printing area is much reduced. Taking the model that is being used to test the proof-of-concept cell, for example, it would have to be presented to twenty two different machines compared to the present seven. If no other changes were made, for example a flow line operation, then this would increase decoration time to between five to six weeks. This is clearly an undesirable situation especially as the machines cost around three times that of a conventional machine.

1.5.4 Fully Automated Systems.

In 1991 an automated Tampo Printing system became available using multi closed ink systems

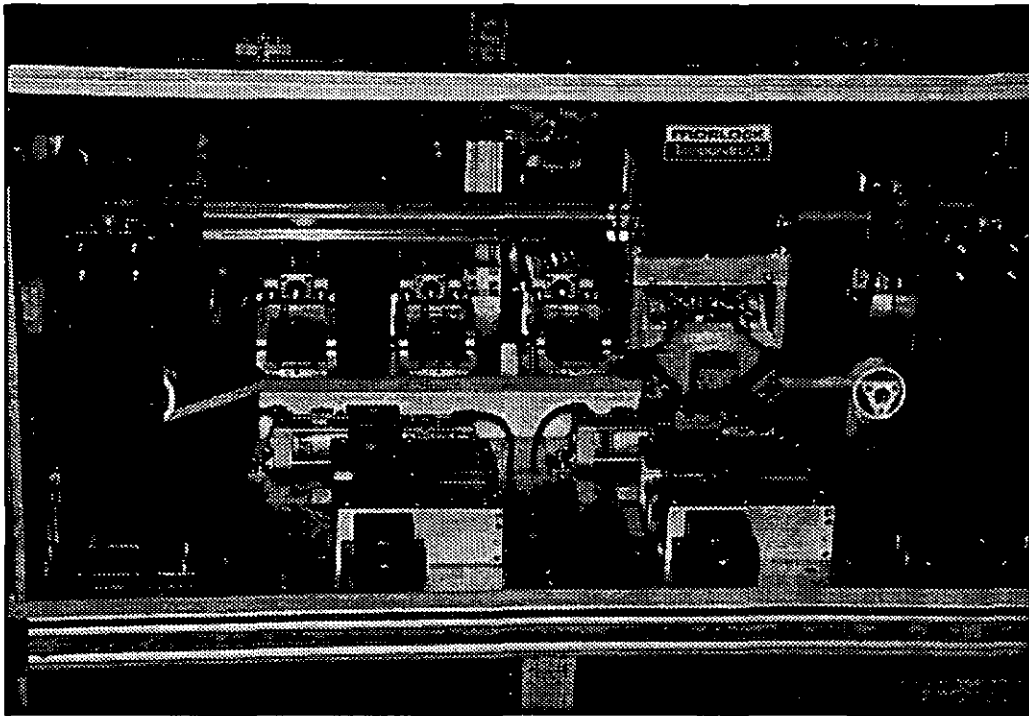

Figure 1.10: Automated print system.

with multi etched clichés, an X-Y arm arrangement using programmable pneumatic cylinders and a multi-pad rotary head. The manufacturers claim to have solved all of the problems associated with tampo printing giving very good values for repeatability (better than 0.01 mm), and the machine occupies a 3 meter square floor area.

The set up time is said to be low, although no indication is given as to how the arm is 'taught' the various cliché and print points. As yet there is no automatic method for loading or unloading the machine even though the work throughput is potentially high so an operative is still required. Taking the Sierra as a trial sample a cycle time of 60 secs was quoted for complete decoration.

The cost of £120,000, however, is twenty times that of an open ink machine and nearly eight times that of a standard closed ink machine.

1.6 THE NEED FOR DECORATION

The current necessity for the decoration of a finished product is overwhelming. It is a sad fact of life that plain objects just do not sell as well no matter how well it functions or technically advanced the product may be.

This need for decoration is even more important in the scale model industry where the full sized prototype is now a very colourful indeed and as such the models have to remain as true as possible to the real car or train as even the youngest user is very highly critical of the final finish of the model.

The following two figures illustrate these points. Figure 1.11 reflects how cars used to be in the mid 1960's with just a number stuck on the doors and bonnet and the current trend in the 1990's with highly sponsored cars. The Mini was following the trend with a simple stick on number and the latest cars are using multiple overlay printing.

Put the two cars in Figure 1.12 side by side on a display cabinet shelf and it is obvious which one is going to sell.

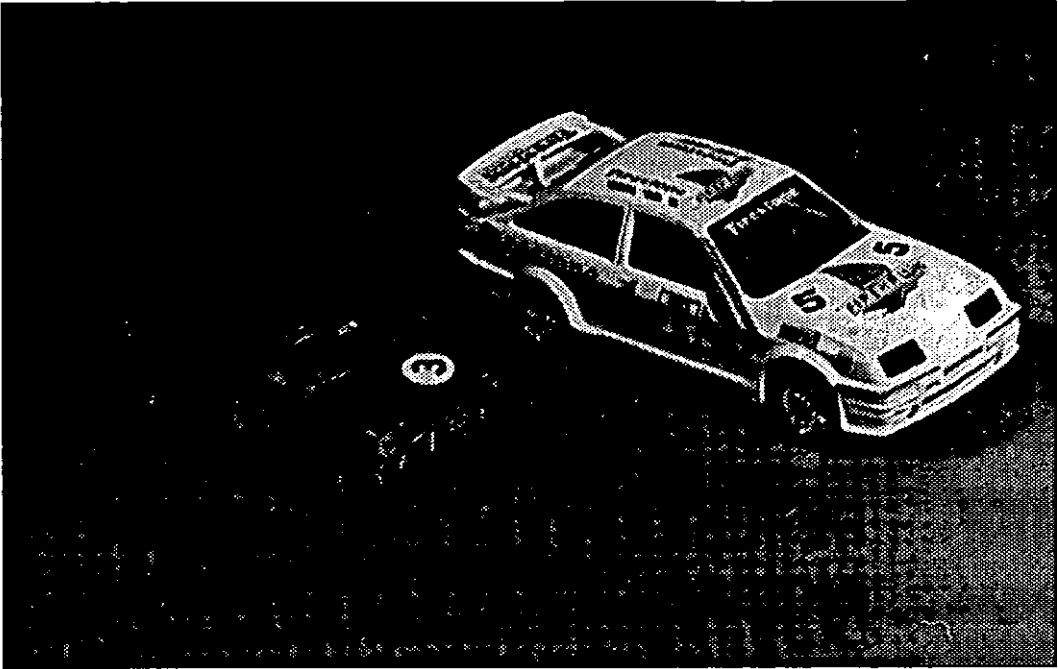

Figure 1.11: The improvement in decoration quality.

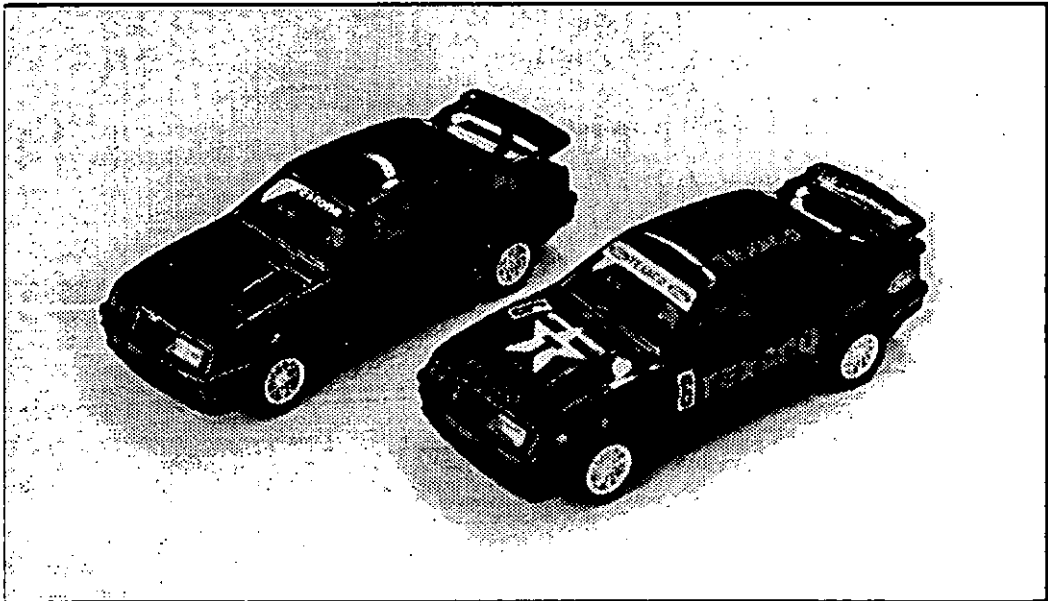

Figure 1.12: The importance of decoration in the scale model industry

1.7 AN HISTORY OF SCALEXTRIC.

Before going further, a brief outline of the history of Scalextric follows so that the reader will have some understanding of the evolution of the product and may gain an insight into the way in which the product is marketed.

- 1952:** A small company called Minimodels Limited introduced a range of metal bodied cars with a novel clockwork motor. These were models of sports and racing cars and their trade mark was SCALEX.
- 1956:** The inventor/proprietor of Minimodels, Mr. Fred Francis, modified three of the cars to take an electric motor and devised a rubber based track system with two parallel grooves in which metal rails carried electric current and guided the cars by means of a 'gimbal' wheel suspended beneath them. The new product was called SCALEXTRIC (Scalex-electric). These cars were the Austin Healey 100/6, Ferrari 4.5L 375F1 and the Maserati 250F.
- 1957:** Scalextric was unveiled to the toy trade at the annual Harrogate Toy Fair causing an immediate sensation, and orders flowed in far in excess of the factory production capability. As an alternative to making substantial investments in a new factory, Minimodels was sold to the Tri-ang Group in 1958.
- 1960:** Tri-ang launched four new cars fitted with the well tested RX electric motor and accurately moulded plastic bodies. A variable speed control replaced the original 'dabber' type controller. These first true Scalextric cars were the Lotus 16, Vanwall, Lister Jaguar and Aston Martin DBR and all had stick-on number discs.
- 1961:** A 24 page catalogue revealed a host of racing accessories, bridges and bankings based on the real items to be found at Goodwood circuit in Sussex. Such was the demand that a new factory was built solely for the purpose of manufacturing Scalextric. The advantage of large scale production enabled the cost of individual cars to be reduced from 32/6d (£1:62) to 29/11d (£1:50).
- 1963:** The original rubber track, supplied by a contract rubber supplier, was replaced by a polyethylene track and was moulded at the Tri-ang factory. By this time the range of cars had extended to 18 plus two motorcycle combinations and two Go-karts. The two Formula Junior cars, which had sprung rear suspension and steering, cost 15/11d (80p) each.
- 1964:** Scalextric was being manufactured in Tri-ang factories France, Australia and New Zealand and by an associated company in Spain. It was sold in America in partnership with

Lionel, the famous train makers. Jim Clark, the Formula One World Champion, was retained for promotional purposes and a Scalextric World Championship was staged in London, to be repeated on alternate years into the 1970's.

- 1965:** Two gimmicks were introduced, the blow-out puncture simulator and Twin Auto screams, a realistic noise making device not universally popular.
- 1966:** Race Tuned cars were introduced with a significantly higher performance requiring a more robust hand control. This controller was wired with 'brakes'.
- 1967:** The Scalextric 1/24 scale cars were introduced, aimed at clubs and 'slot shops', but unfortunately they were introduced too late as this market was being eroded by other interests and only a small quantity were ever made. They were, nevertheless, really beautiful models.
- 1968:** A tapering off of demand and the heavy investment in 1/24 meant that prices started to rise. The only new products were the 'Power Sledge' and the 45° banked track section, which required special adaptors as the track centres did not match the original track for some reason.
- 1970:** In an attempt to revive flagging sales another gimmick was introduced 'You Steer', a special hand control with a small steering wheel. As this was turned it changed the polarity of the current to the car and by an amazingly ingenious and simple device, made the car swerve whilst maintaining its forward direction so that it could, to a degree, avoid obstacles in its path. Although the theory and engineering were sound, the driver had little time to carry out the manoeuvre. 'You Steer' was not a success and Minimodels Limited was in some difficulties. The decision was taken to close the factory and transfer production to an associated company, Rovex (now called Hornby Hobbies Limited) at Margate. Rovex produced Tri-ang Hornby model trains and were familiar with the type of production needed for Scalextric.
- 1971:** A new 60° banked curve was introduced which connected directly to all the other track sections allowing a banked figure of 8 circuit to be constructed with only 14 track sections. This move has been universally regretted ever since, as to enable cars to use the banking, it has been necessary to manufacture cars with the front "wheels" clear of the track and provide a lot of free vertical movement in the axle.
- 1973:** Even so all new sets were supplied with banked curves. Three new cars were introduced of exceptional quality, a Ferrari, JPS Lotus and March.
- 1977:** A start was made with printing the insignia directly onto the cars to replace the transfers still being used at that time. This immediately improved the quality and durability of the

models. Gimmicks were carefully avoided throughout the rest of the 1970's.

- 1980:** The early 1980's were a difficult time with instant appeal of the home computer undermining Scalextric sales. New ideas were needed.
- 1982:** Trucks were the first of these new ideas taking their lead from the tremendous interest in Truck Racing in Europe. Unfortunately these were not marketed properly and a golden opportunity was lost.
- 1983:** Gimmicks were back. A new blowout set was introduced and a loop-the-loop track section was added. A Trackbusters set was also introduced incorporating special pickup trucks with 'flip mechanisms' at the rear and using a special transformer so that single lane 'racing' could take place. None of these gimmicks remained in the catalogues for long. The first four wheel drive car was introduced.
- 1986:** Electronics started to make an appearance on Scalextric cars. Brakelights on the saloon/sports cars and 'Turboflash' on the Formula One cars. 'Magnatraction' was introduced on some cars to improve the performance and handling of the cars. In reality it was needed as the new motors being supplied were too powerful and the tyres could not provide the necessary grip for the relatively light cars.
- 1987:** The 30th birthday of Scalextric passed quietly with no mention from Margate.
- 1988:** The interest in the World Sports Car Series was at last satisfied with the introduction of a Jaguar XJ8 and a Porsche 962 to supplement the continual repaints of old models. The Super Racing Series of cars from the Spanish factory were included in the catalogue.
- 1991:** The first new car for some years appeared in the catalogue.
- 1992:** Three new cars and 9 re-issues in new 'Power and the Glory' series of 1960's cars, things seem to be looking up for the rest of 90's.
- 1993:** Two new cars introduced with a modular chassis design to improve production rates. Horse racing sulkies make an appearance. New track accessories for 1993 are the Power Base Megasound hand throttle to "... create the right atmosphere for some really serious racing."

From reading the above it could fairly reasonably be concluded that Scalextric has lurched from one crisis to another in the middle to recent years. Certainly this is true of the manufacturing base, and to a certain extent with not enough thought from the design/marketing teams, and if it were not for the tremendous loyalty of its customers then neither the name nor the product would not have survived at all, as there have always been other, and cheaper, systems to choose from.

This is probably a harsh, though true, judgement as today the accuracy of the moulding is superb and the quality of the colours and decoration outstanding. In 1991 Hornby manufactured 29 different types of car with a total of 65 different colour schemes at an annual production rate of 750,000 units. The figures for 1992 were 40 cars (plus Turtles and horses) with 70 colour schemes at a rate of 1,250,000 units and in 1993 35 cars and 71 colour schemes are being produced plus horses.

1.7.1 Future Plans.

Even though the company has a new model lead time in the order of 18 months, this is not a luxury it can afford to maintain due to the ever increasing competitiveness of its once partner, now arch rival, in Spain. Hornby Hobbies Limited bought its first CAD workstation in 1989 for the design office. The aim was, and still is, to design all the parts on the workstations in order to build up a library of standard items to be included in future designs. The ultimate aim is a paper-less design office.

Another area of particular importance is the manufacture of the dies for the injection moulding machines. These have been made outside by a tool maker in Margate since the move in 1970 and this has led to unacceptably lengthy manufacturing times, especially if there has to be a modification.

Hornby hope to shorten this time by generating a 3D model of the product using the software package Deltacam DUCT, from which the NC machining data can be extracted, and sending this to the tool maker. Eventually this is planned to be a totally in-house service. This package can also help to control the injection process itself as it allows for the simulation of the plastic flow in the mould, and so it can be used to avoid weaknesses and stresses in the finished product.

CHAPTER 2:
CONFIGURING THE CELL.

2.1 SUMMARY.

This chapter deals with the various problems that were foreseen at the start of the project, and outlines the possible solutions; it also deals with those that were not, and which consequently forced changes to the strategy of the decoration cell.

That there is a need for a decoration cell is not challenged, it is just the precise configuration that needs careful consideration, especially in view of the recent advances in commercial 'off-the-shelf' systems. It is felt, though, that the Loughborough approach has been the right one enabling a deeper understanding of the true nature of the problems experienced with this type of operation. To date every commercial system has had some level of compromise and it is hoped that the outcome of the project will show that this need not be the case.

2.2 THE FORESEEN PROBLEMS.

These problems can be split into the following main areas;

- transporting the bodyshells
- handling the bodyshells
- identifying the bodyshells
- decorating the bodyshells
- inspecting the decorated bodyshells.

2.2.1 Transporting the bodyshells.

This is an important point for many reasons. The various operations are carried out in different parts of the factory and so the system chosen must be flexible so that it is be capable of dealing with all the different models produced, trains as well as cars, and not take up valuable floor space that could be used for other operations.

At present, as the bodyshells are expelled from the moulding machine they drop into a cardboard box which, when full, is changed for an empty one. The bodyshells are then manually

inspected for 'flash' and moulding flaws before being wrapped in tissue paper and packed in cardboard boxes prior to being transported somewhere for storage. Eventually they will be distributed amongst the various printing machines and then on to assembly.

It was not within the scope of this project to investigate in depth the various possible ways of transporting the bodyshells to the decorating cell, however, one way could be to extend the existing conveyor systems in the factory. For the purpose of this project, it was assumed that the same initial inspection of the bodyshells would be maintained and that they would always arrive at the decorating cell in an upright position.

After consideration, a simple chute loader with a two degree of freedom mechanism was chosen as the input to the cell.

As previously stated, presently the bodyshells are inspected, rewrapped and repacked after every decoration operation. This is very wasteful both in terms of manpower and materials. Also no orientation is maintained between operations. It was thought that it would be much better if the bodyshells could be palletised in some way, then they could be kept in a known orientation and it would also save on tissue paper and boxes. If they were going to be put in some sort of storage buffer then the whole pile of pallets could, if necessary, be sealed in polythene film or plastic.

Hornby Hobbies made some pallets to our design to enable trials to be conducted. To cope with the various positions on the pallet and the differing height of the pallet stack a simple robot was required to load them. A UMI¹ RTX robot this was used for this task.

2.2.2 Handling the bodyshells.

To minimise possible damage to the bodyshells the less they are handled the better. Presently the bodyshells are handled many times before they are fully decorated, and the printing machine operator has to perform a juggling act with two, three or sometimes four bodyshells at once. The bodyshells are made from either Acrylonitrile Butadiene Styrene (ABS) or Cellulose

1. Universal Machine Intelligence.

Acetate Butyrate (CAB) which, though flexible, is very susceptible to surface damage.

Whatever system is finally chosen to handle the bodysHELLS it has to be 'surface friendly' in that it should not mark them. There is one other constraint in that it also has to be capable of picking them up without distorting them as the bodysHELLS are fitted onto a precise male mould known as a matrix (Figure 2.1) during the actual printing operation.

A secondary problem is that because of the shape of some of the models it is not always possible to fit them with a straight downwards motion, they have to be almost rolled on lengthwise.

The most frequently used grasping principles are:

- mechanical
- electrostatic
- magnetic
- vacuum
- adhesive.

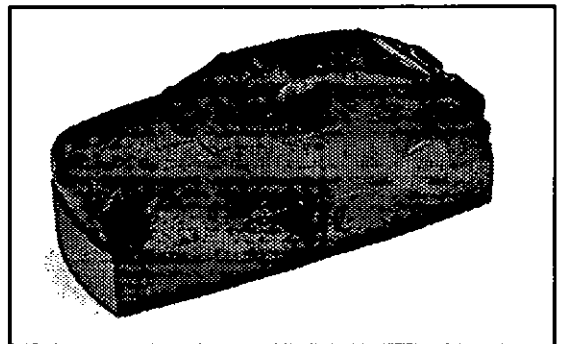

Figure 2.1 Print matrix used in the decoration operation.

The magnetic principle is ruled out because of the material, the adhesive principle because it would mark the bodysHELLS and the electrostatic principle because the electrostatic charge might repel the paint. The main problem with the mechanical principle is controlling the force applied to the end-effector because the bodysHELLS deform very easily. The consequence of this being that it would be impossible to fit the bodysHELL onto the matrix.

Therefore the solution is to use a vacuum. The practical way to implement this is through vacuum cups, also called suction cups. These have a venturi inside the body and all that is required for successful operation is a stable air supply (Figure 2.2).

Although most bodysHELLS contain surfaces with recesses and protuberances, it is always possible to find a flat area. However, the size of this area and consequently the size of the suction

cup could be an operational problem, as the lift capacity of the suction cup depends on the effective area of the cup, as illustrated in Equation 2.1.

$$F = PA \quad (2.1)$$

where F = the force or lift capacity, N.
 P = the negative pressure, N/mm².
 A = the effective area² of the suction cups used to create the vacuum, mm².

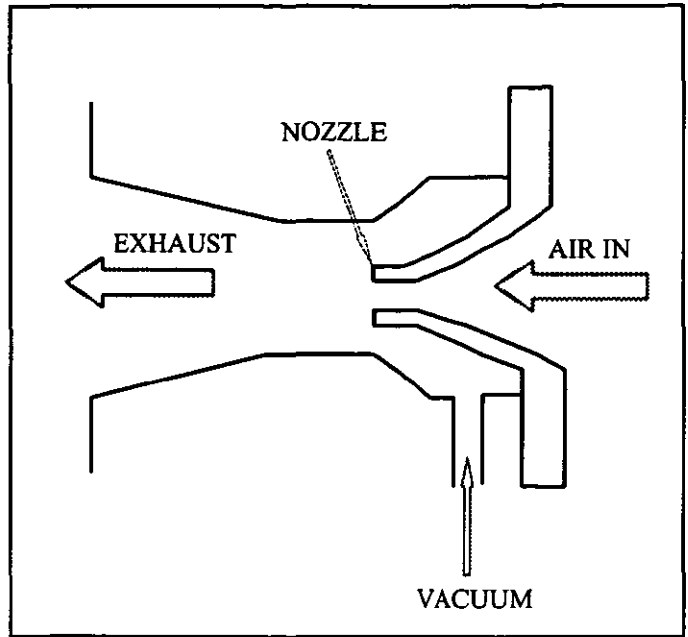

Figure 2.2 The venturi principle.

Because the bodyshells are so light, 17 grams on average, the diameter of the suction cup could be as small as 5 millimetres to produce the necessary lift capacity. The commercially available range is from 8 to 400 millimetres and a 10mm cup was chosen.

2.2.3 Identifying the bodyshells.

Somewhere in the system there has to be a means of identifying what is entering the decoration cell. In the simplest case this could merely be a person loading the input buffer with the correct models for the days production, but the sheer tedium of the job would sooner or later lead to errors. An automatic non-contact (preferably) method is needed.

The things that have to be checked for are:

² The effective area of the cup during operation is approximately equal to the undeformed area determined by the diameter of the suction cup. The squashing action of the cup as the object is pulled against it would tend to make the effective area slightly larger than the undeformed area.

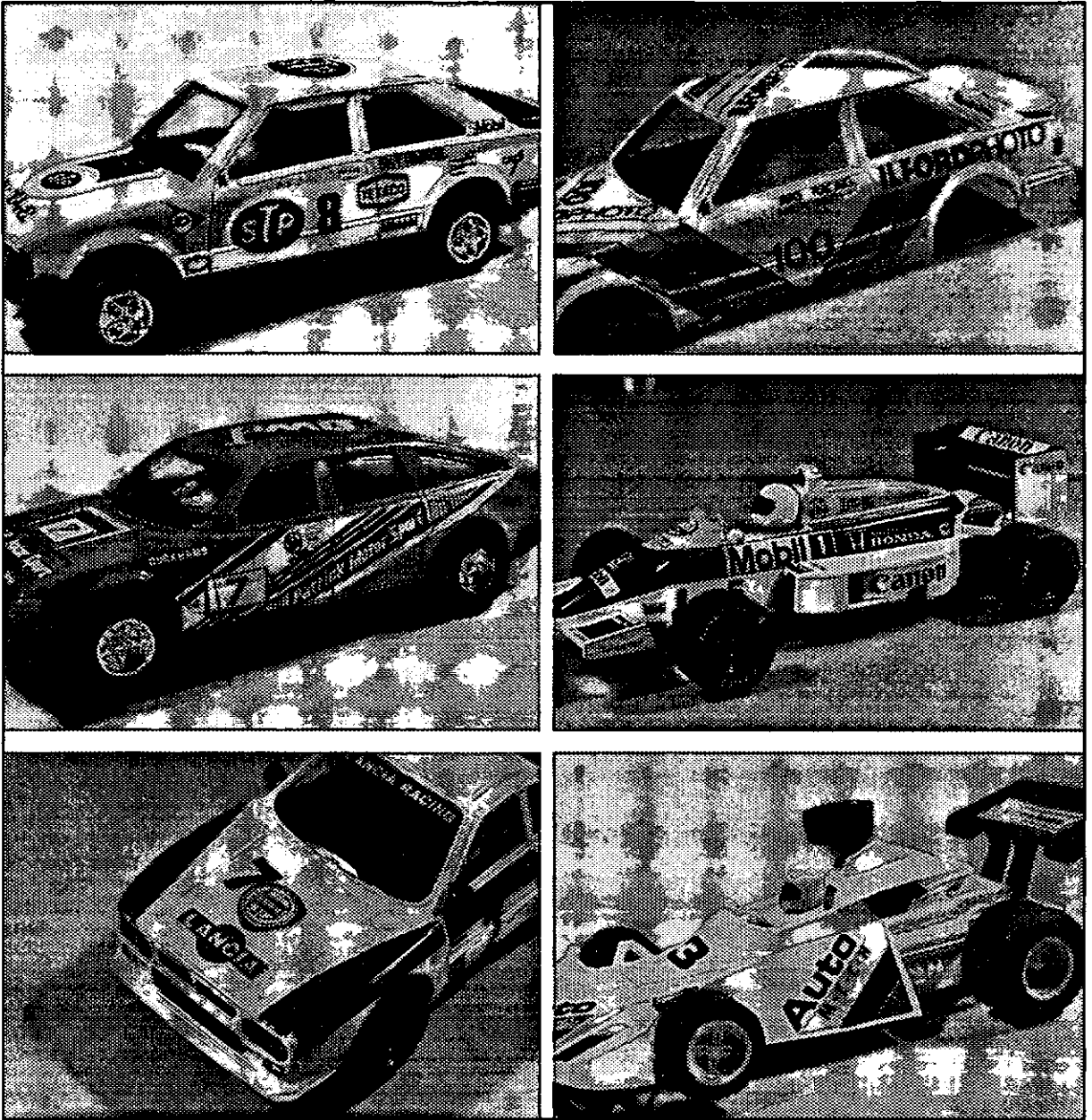

Figure 2.3: Examples of complex logos.

- bodyshell style
- colour
- orientation and position
- up rightness.

It is essential to know if it is the right model for the current decoration set up has been chosen, as the wrong model will not fit the print matrix. Colour is also important as different colour

models require different decorations³, and clearly it must be the right way up. Orientation and position pose the same questions to the handing mechanism.

Bar codes are a possible answer to the first two questions but not the second two, and it is not easy to attach them without marking the model or getting them in the way of the decoration. This may be done on the inside, maybe, but then they would be impossible to read. A sophisticated mechanical means could cope with the last two points, and maybe the first, but not the second. It would also have to be different for every model.

A much more flexible arrangement is to use the same system as does a person, namely vision. With a colour machine vision system the answer to all the problems is readily obtainable and can be output in human or machine readable form. This type of system would provide the greatest flexibility for all current or future production, with, if it was programmed correctly, very little training for new models.

2.2.4 Decorating the models.

An important feature of the present factory production method is that each printing machine is set up to print two, three or sometimes four models at once. This could be simply the printing of different decorations on different areas⁴ of the cars or using the wet on wet technique to build up complex logos or colour schemes (Figure 2.3). As previously stated this sometimes leads to the operator performing a juggling act with the models, and quite apart from the potential damage point of view, this is not a good idea with wet paint on the models.

This constant swopping from one matrix to another must be avoided in the design of the decoration cell. The approach finally settled on was to fit the bodyshell onto a matrix at the start of the operation and then move the matrix, complete with bodyshell, from position to position. In this way the bodyshell is only handled twice, once to put it on the matrix and once to remove it, and there is no reason why it should not stay on the matrix until it had been inspected.

³ If the wrong colour bodyshell was decorated these would in essence be scrap, but there are people who are prepared to pay high prices for them so maybe there is a place for them in the production cycle.

⁴ Bonnet, roof, left side, right side, back and front.

Obviously this would require some form of fairly specialised handling mechanism that could get the matrix into the various printing orientations. To achieve the best results with pad printing the surface receiving the decoration should, if possible, be horizontal. Certainly with the models of cars this means that the mechanism must be capable of getting into some interesting orientations (Figure 2.4).

This matrix-bodyshell approach was suitable for a flow line operation as the mechanism that transferred them between printing machines⁵ should also transfer them to the inspection station. As an initial approach to the problem it was decided to use a six degree of freedom robot arm as this has the capability of reaching complex orientations and also has a large working envelope. The arm used was a PUMA 562⁶ and this has allowed valuable lessons to be learned about the whole strategy.

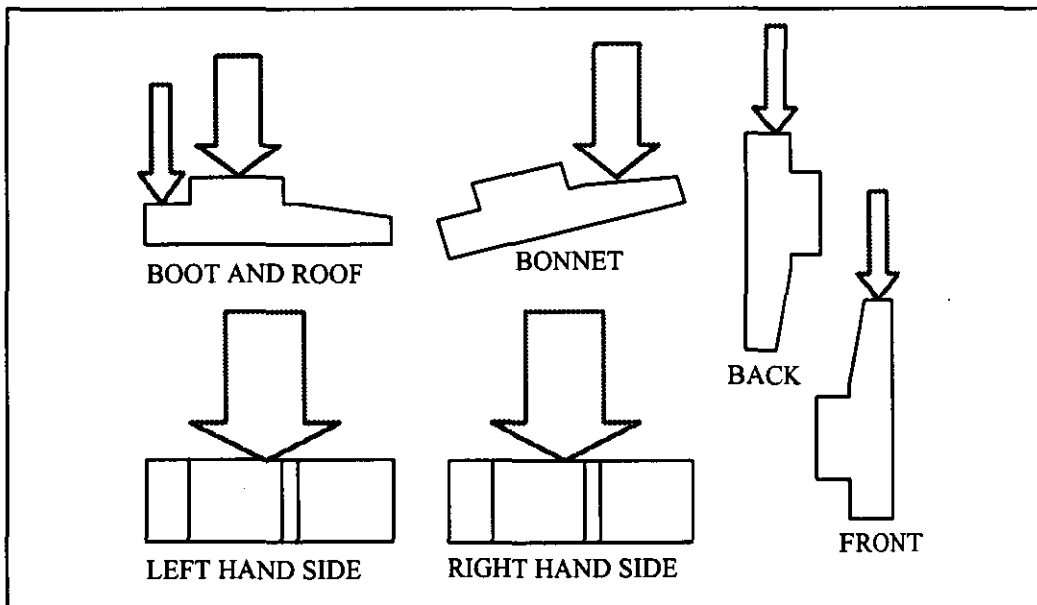

Figure 2.4: The various orientations adopted by a bodyshell during decoration.

⁵ An average number of machines needed for completion of the decoration is seven. Hornby Hobbies did not provide this number for obvious reasons. The one machine supplied, however, was sufficient to demonstrate the principle of operation.

⁶ Programmable Universal Machine for Assembly.

2.2.5 Inspecting the bodyshells.

The logos of the decorated bodyshell need to be inspected for:

- position
- size
- completeness
- shades of colour.

There is only one possible method to carry out this final important task - Vision, either real or artificial. If it is accepted that human operators are prone to error due to tiredness and boredom through a repetitive task, then the task defines the only possible alternative solution. It also justifies the purchase of a system for identification as the same system can be used for inspection by switching cameras with software during the operation of the cell.

All the items selected above for inspection can easily be checked by any suitable commercial vision system. To buy such a system and plug it into the cell would not be in accordance with Mechatronic principles, and it probably would not work any way as there are a number of different items to interface to, and this causes problems when the values of some of the parameters change.

2.3 THE UNFORESEEN PROBLEMS.

2.3.1 Conveying the models and lighting arrangements.

The first problem was a combination of transporting and identifying the bodyshells. To give some sort of realistic movement to the bodyshells into the decoration cell a Bosch modular conveyor system was used. It first had to be established how the bodyshells were going to be

conveyed on the workpiece carriers.⁷ If a carrying jig was used then this would have to be changed for every model change and it would also be expensive as a large number of jigs would be needed⁸. As the bodysHELLS were going to be identified by vision, it was decided to leave them loose on the workpiece carriers and use the vision system to find them.

It then had to be established where should the camera be mounted and how. Normally cameras are mounted on some fixed gantry over the area where they are expected to be. This is fine except that it can restrict the way into and out of the inspection area for the robot. Also if something goes wrong with the control programme then quite extensive damage can result. There is another problem in that the workpiece carriers are a matt black finish and the dark bodysHELLS do not stand out from the background. Putting a coloured top onto the workpiece carriers does not help much as then the light coloured bodysHELLS do not stand out.

In an effort to try to simulate as nearly as possible the environment at Hornby Hobbies Limited, all of the earlier experiments were carried out using overhead fluorescent lighting which proved to be very problematical with regard to the identification of the bodysHELLS by the vision system. These problems were caused by reflections from the bodysHELLS and shadows. The reflections were caused by the nature of the bodysHELLS which are glossy with curved surfaces and the shadows by the positions of the lights relative to the camera and the bodysHELLS themselves. The surface of the workpiece carriers, although described as matt, was also prone to reflections.

Many experiments were carried out with tungsten lights, polarising filters on the camera and diffusers in front of the lamps but these only went part of the way to solving the problem. The final experiment with tungsten lighting was to build a station with four horizontally mounted lamps, level with the conveyor at the corners of the workpiece carrier, and with the overhead lighting blocked out. This proved to be very successful with lighter coloured models but with darker models, edge and feature detection were still considerable problems.

The system was now becoming increasingly specialised and in consequence, the working area for handling the bodysHELLS was much reduced with very little room for error in movement. At

⁷ The term used by BOSCH to describe the unit for moving the items around the conveyor system. Usually referred to as a pallet.

⁸ At least at Hornby Hobbies, as the trial system was small.

this point it was becoming increasingly obvious that a complete rethink was necessary to allow the use of vision to identify the bodysHELLS. The classical way to illuminate to identify an object is to use backlighting {Ruocco, 1987}, but how was it possible to backlight through a solid object?

Various methods were investigated involving lamps and mirrors, but the need to keep the cost and the overall height of the workpiece carriers down ruled most of these ideas out. After considerable debate and 'brainstorming'⁹ the idea was hit upon to 'backlight' by the object by an indirect means involving the shining of light through the sides of a perspex¹⁰ block, the horizontal surfaces of which have been specially prepared to maximise the specular reflection of the light {Trabasso et al, 1990}. Because the light sources are located at the sides of the object, the method was called side lighting. (Figure 2.5).

Each perspex block is approximately twice the size of the original workpiece carrier and is located on top of it by a plate which fits into a recess on top of the workpiece carrier, and is held in place by a single screw from underneath. The block is lit from two the sides parallel to the edge of the conveyor by two 60 watt tubular bulbs. A specially made reflector with a small opening at the front concentrates the light into the perspex block. Because the heat generated by the bulbs is concentrated into the edge of the perspex block the lamps are only lit for a short period, just long enough for the vision system to take a picture of the scene to be analysed.

Painting the underneath white and beadblasting the top has helped to sharpen the image and using the side-lighting system even the reflections on top of the models do not cause problems any more. Figure 2.6 shows the improvement in image quality produced using this system. A white bodysHELL on a white background (Figure 2.6 a) represents the worst case in terms of contrast definition, but when backlit (Figure 2.6 b) a very definite shape is highlighted.

The side-lighting arrangement allows for two adjustments, one mechanical and one electrical, both with a direct effect on image quality.

⁹ A favoured Loughborough technique for solving 'insoluble' problems, whereby all the people involved in a project shut themselves in a room and only come out when a viable solution has been found.

¹⁰ ICI trademark or polymethylmethacrylate.

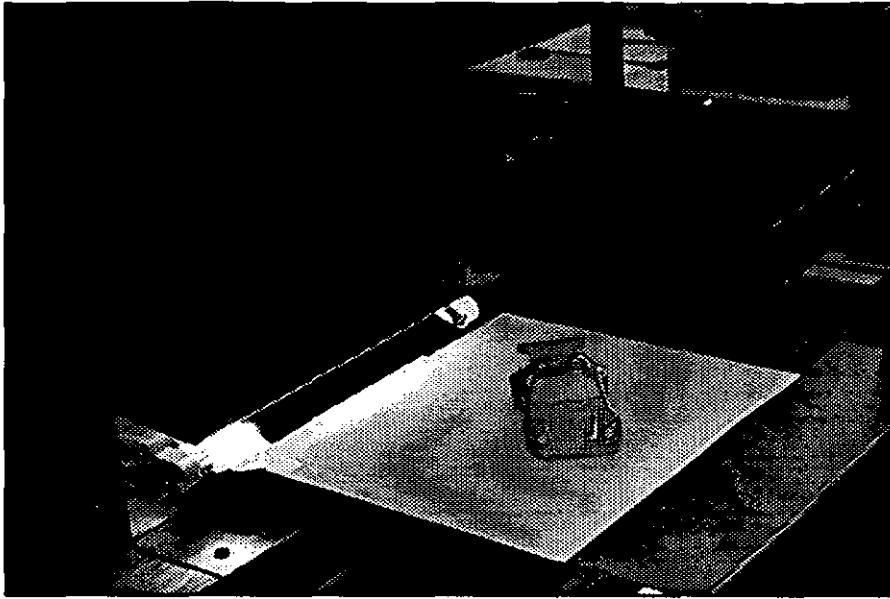

Figure 2.5: Side lighting at the identification station

All this has directly effected where the camera should be placed, and to save expensive fixturing the camera was mounted on the robot arm. This has two advantages first the bodyshell is not moved between being photographed and picked up and secondly the camera is available for use in other tasks.

2.3.2 *Parallax error.*

Whilst learning to use the vision system simple flat cardboard shapes had been utilised to gain experience of writing programmes and using the inbuilt routines. The initial trials on the bodyshells were carried out using a parallel motion jaws type end-effector with foam padding to avoid damaging the bodyshells. This was basically to test the interfacing between the vision system and the PUMA controller and also as at this point no firm decision had been taken regarding the best type of end-effector to use to pick up the bodyshells.

It was with some surprise, then, that when trials began using the vacuum end-effector the robot seemed unable to locate the pickup point, which was the centroid¹¹ of the model, when the bodyshell was in certain locations on the workpiece carrier. The phenomenon observed was that the centroid was moving within the boundary of the bodyshell, following, to some extent, the different orientation angles of the bodyshell.

¹¹ Known as the 'Centre of Gravity' in artificial vision parlance.

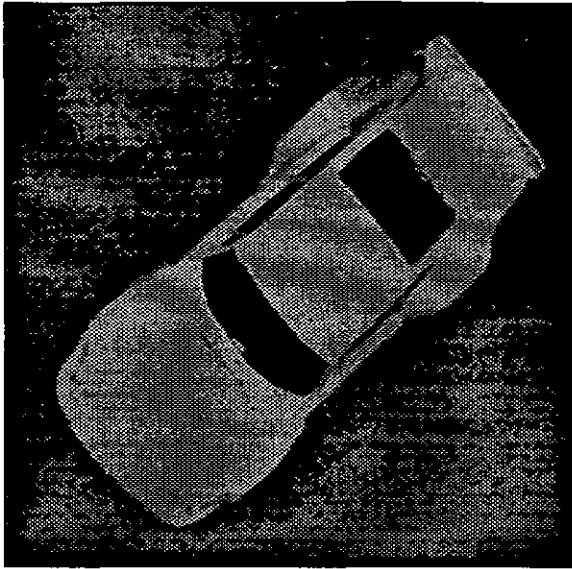

Figure 2.6 (a): Without side lighting.



Figure 2.6 (b): With side lighting.

After checking that the errors from the calibration procedures were within the expected limits, it was concluded that the apparent movement of the centroid was being caused by optical illusion. This illusion was caused through viewing a three dimensional object with a two dimensional system. This was proved by two independent means, (a) closer visual inspection and (b) by replacing the bodyshell with a two dimensional object.

(a) Closer visual inspection.

This can be seen in Figure 2.7, where two bodyshells are placed in different locations and orientations on the workpiece carrier. Note how the centroid¹² is different for each bodyshell. This is caused by certain features of the bodyshell being masked in different locations.

(b) Absence of optical illusion with a two dimensional object.

By replacing the bodyshell with a flat 2-D representation of the bodyshell, complete with window cut outs, the shifting of the centroid vanished (Figure 2.8). There are a number of solutions for overcoming this problem of optical illusion such as stereo vision, structured lighting

¹² Marked with a cross in the pictures.

{Fu et al, 1987} and artificial intelligence techniques {Waldon, 1988}. In trying to keep the solution as simple as possible the problem was solved by redesigning the end-effector and fitting sensors around the vacuum cup (Figure 2.9).

2.3.3 *Repositioning device.*

This solution brought about another problem in that the grasp point was now no longer the Centroid of the model, or indeed a known point. To ensure correct fitting onto the matrix it is essential to know where the bodyshell has been picked up. To overcome this problem a neat repositioning device (Figure 2.10) was constructed whereby the bodyshell is dropped into an angled tray and allowed to slide down to one corner, whereby its Centroid is then known. The end-effector can then be repositioned to grasp the bodyshell at the correct position.

2.3.4 *Accurate location at the printing machine and inspection station.*

One quite major problem that had not been fully appreciated at the outset of the project was that of the positional accuracy, or repeatability, of the various robotic arms. When building up a complex logo very high repeatability¹³ is called for which is far higher than most manufacturers are prepared to quote. As mentioned in Chapter 1 there is no special jiggling in use at Hornby Hobbies Limited for the accurate placement of the matrices in front of the printing

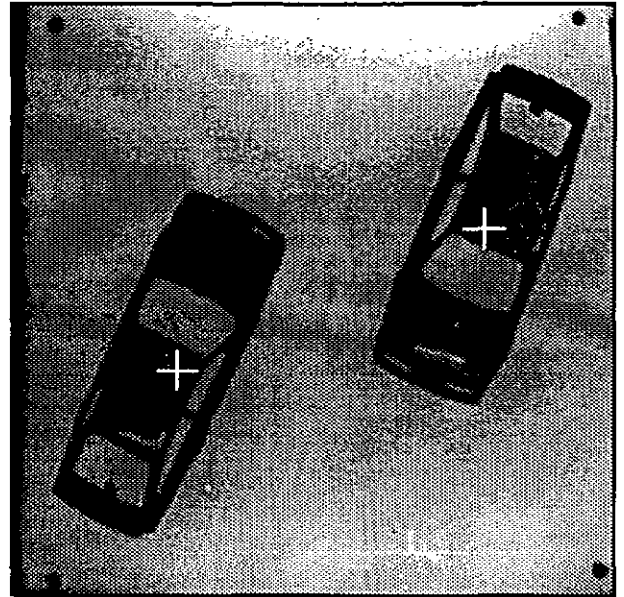

Figure 2.7: The optical illusion phenomenon caused by lack of depth information.

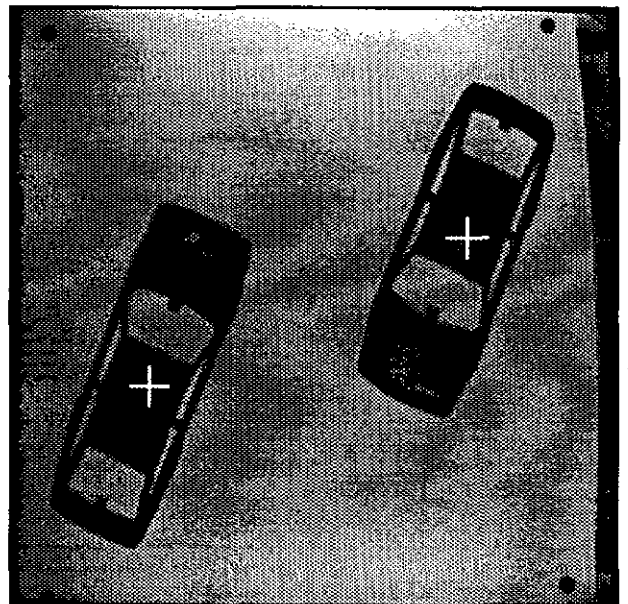

Figure 2.8: Using a 2-D representation of the bodyshells.

¹³ 0.0005" or 0.01mm.

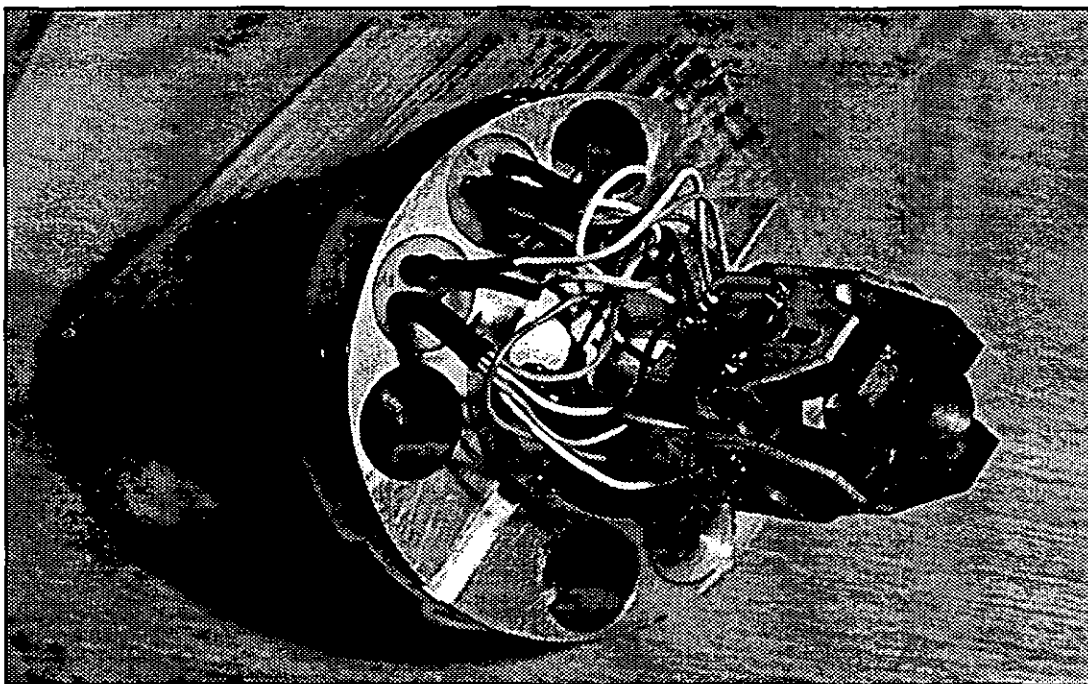

Figure 2.9: The sensors around the vacuum cup.

machines, therefore a design exercise to produce suitable jiggging that could be used for both robotic and manual operation was undertaken. The parameters required were that it should:

- be easily fitted to the worktable at the front of the printing machine
- be adjustable to allow for each surface to be horizontal for printing
- have accurate ($>0.01\text{mm}$) placement accuracy
- be usable to both the printing machine and the identification station
- be easy to use.

2.3.4.1 Fitment to the worktable.

The adjustable worktable supplied with the printing machines is fitted with 'T' slots, therefore 'T' bolts were the only sensible answer to this problem. This allows for X-Y adjustability.

2.3.4.2 Adjustment of the angle for printing.

The range of angles through which the various faces of the bodyshell have to be moved for printing is 0° to 40° (see Figure 2.4). This does not have to be continuously adjustable throughout the whole range, although such a feature would be useful. The design finally chosen was to have a hinged platform with a cam to raise and lower it. Springs are used to tension the platform against the cam. Holes were drilled in the side of the cam so that it could be locked in place at pre-defined angles.

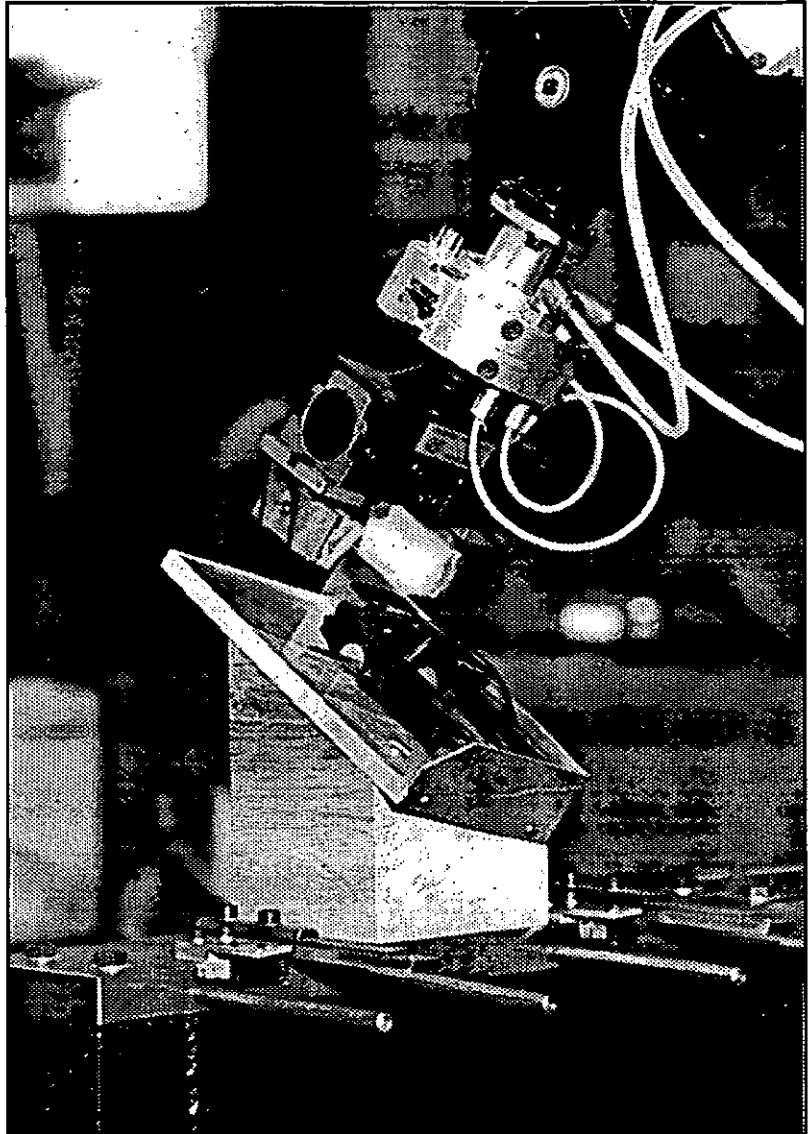

Figure 2.10: The repositioning device.

2.3.4.3 Accurate placement.

The success, or failure, of the decoration process lies in the repeated accurate placement of the bodysells with respect to the printing pads. The robotic on its own is not capable of this repeatability therefore some additional means of accurate placement is called for. Various ideas using slides and mechanical locking were investigated but in the end the method chosen was simply the peg-in-a-hole approach. With this method great accuracy can be achieved even when using an arm with poor repeatability.

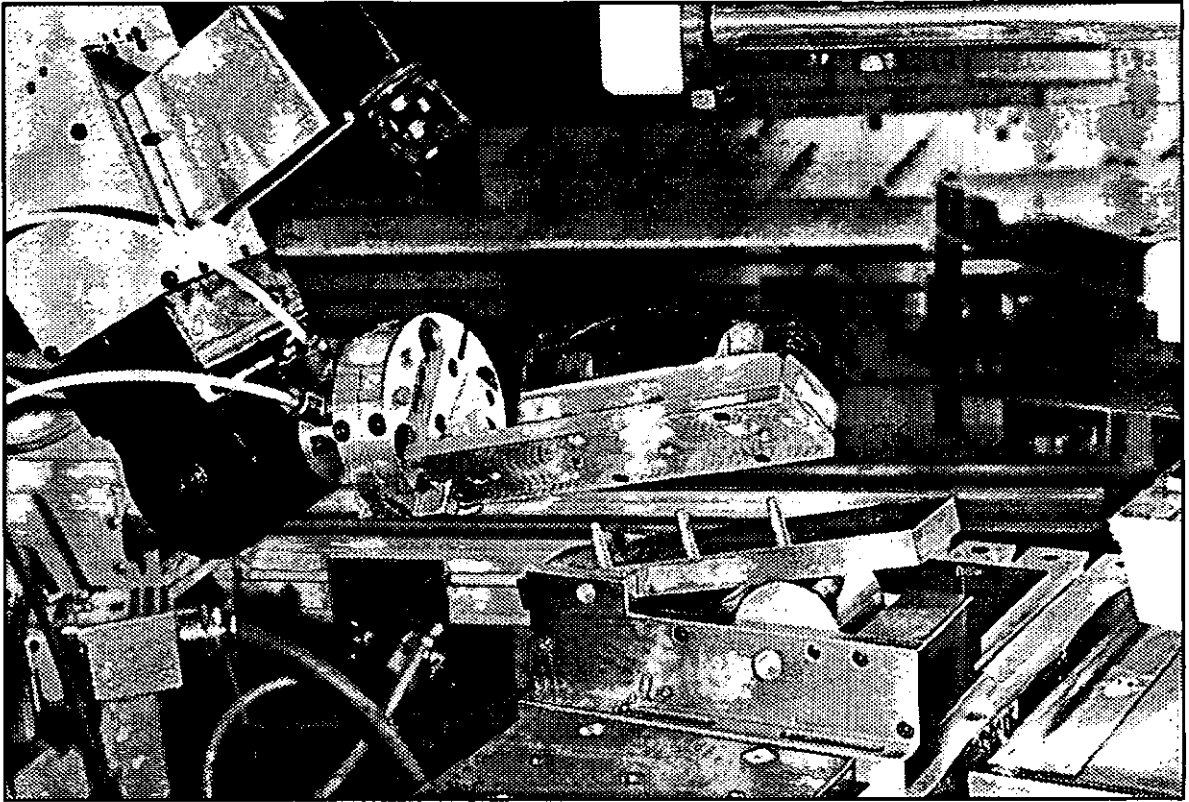

Figure 2.11: The arrangement of the pegs and holes

A single peg on its own would not be good enough as this would allow the matrix to rotate about the axis of the peg. Because the model is divided (for our purposes at least) into three areas a system of three pegs and four holes was devised (Figure 2.11).

This allows for positioning of the matrix in the three longitudinal positions necessary for printing the three identified decoration areas, with at least two of the pegs in use at any position to maintain the positional accuracy.

2.3.4.4 Interchangeability.

It is not essential to tilt the model so that the surfaces are horizontal for inspection as the process is simply one of comparison. Therefore a simpler unit could be built without the tilt mechanism at the inspection station. In fact all that is required is a flat plate with three pegs on it. The only constraints are that the pegs are on the same centres as those at the printing station and some adjustment must be built in to align the base with the camera.

2.3.4.5 Ease of use.

The system is easy to use in that the matrix is fitted to interchangeable tooling to become the current end-effector when decorating/inspecting. It is easy for manual use as the matrix can be locked onto the base unit and the bodysHELLS changed over as they are at present.

2.4 HAND OVER FROM INSPECTION TO PACKING.

As the RTX robot was going to be used for palletising the decorated bodysHELLS then some means of moving them between the two robots was called for. By designing the layout of the decoration cell so that the workspace of the two robots interfered with each other it would be possible to effect a direct hand over from robot to robot.

2.4.1 Co-operating robots.

After the models are inspected the PUMA robot arm moves the matrix/bodysHELL to a position that is accessible to the RTX arm and information is sent to the RTX controller informing it of the result of the inspection operation (pass/fail). The RTX arm is then directed to take the bodysHELL from the PUMA (Figure 2.12) and then either palletise it (pass) or place it in a reject area (fail) for possible rework.

Using this approach saves on extra jiggling in the decoration cell and/or additional handling devices. The same hand over point can be used with the PUMA for all bodysHELLS and just the direction of approach and pick up point with the RTX modified for each type of bodysHELL. The end-effector on the RTX is again a simple vacuum cup with no positional sensing as the precise location of the pick point is known.

The pallets will obviously have to be changed for ones with different moulds but this would have to have been done whatever system was chosen.

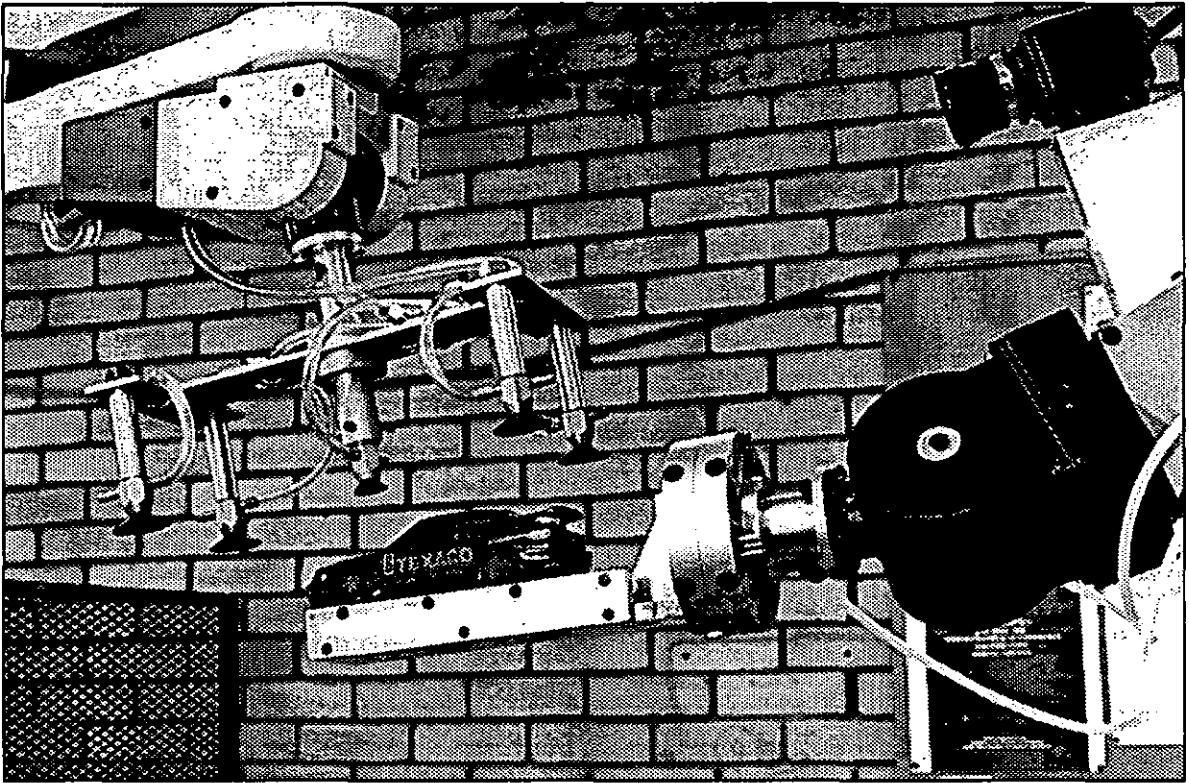

Figure 2.12: Co-operating robots.

2.5 STACKING AND REMOVAL OF THE PALLETS.

No provision has been made for this in the project for, as with the transporting of the bodyshells into the decorating cell, this is outside the scope of the present project. All that has been assumed is that the empty pallets are stacked in the correct orientation on one side of the RTX and that full ones are removed when the stack is five pallets high. Software has been written to prompt the operator to carry out these tasks at the appropriate times.

The RTX transfers the pallets from the 'in' side to the 'out' side as they are required. At present no check is made to find out if pallets are available although this is in the process of being written. Some form of interfacing between the stack of pallets and the RTX control programme will also be required, and for the purpose of demonstrations this will probably be just a simple microswitch.

2.6 CYCLE TIME OF THE DECORATING CELL.

Although no desired figure was given to this by Hornby Hobbies Limited, it has not been ignored during the duration of this project. The theoretical decoration time¹⁴ for the model being used in the proof-of-concept cell is one minute, and whilst this is true, at present the actual time spent in the 'system' is between two and two and a half weeks.

A cycle time of between five and ten minutes was arbitrarily chosen as a starting point to see if this was an achievable figure. The ideal rate would be 180 per hour as this is the rate at which the bodysells are moulded. This would then reduce work-in-progress to zero as they would then be being decorated at the rate at which they are being moulded.

Once the decorating cell was operating though it soon became clear that the approach adopted, that of using a single robot to 'feed' the printing machines, was wrong mainly due to the wasted machine time where it was idling and not printing between cycles.

2.6.1 Improvements to the decoration cell cycle time.

To compete with the present manual method each printing machine has to be full for every print cycle. This effectively means using seven multi arm/end-effector robots in the decorating cell, or at least the same number of robots as there are printing machines required to complete all the decorations on each bodysell. Approaching the problem in this way would make it impossible to justify the cost of the decoration cell. Another approach was called for.

Another brainstorming session followed where simple multi-arm mechanisms similar to that at the loading station were explored and rejected. A conveyor approach was finally thought to be the best approach with a simple loading mechanism and possibly a robot for unloading/inspection/palletising at the other.

¹⁴ This is calculated by adding the individual operation times for each decoration on the model. These times are quoted in hours / 1000 by Hornby Hobbies Limited for accounting purposes.

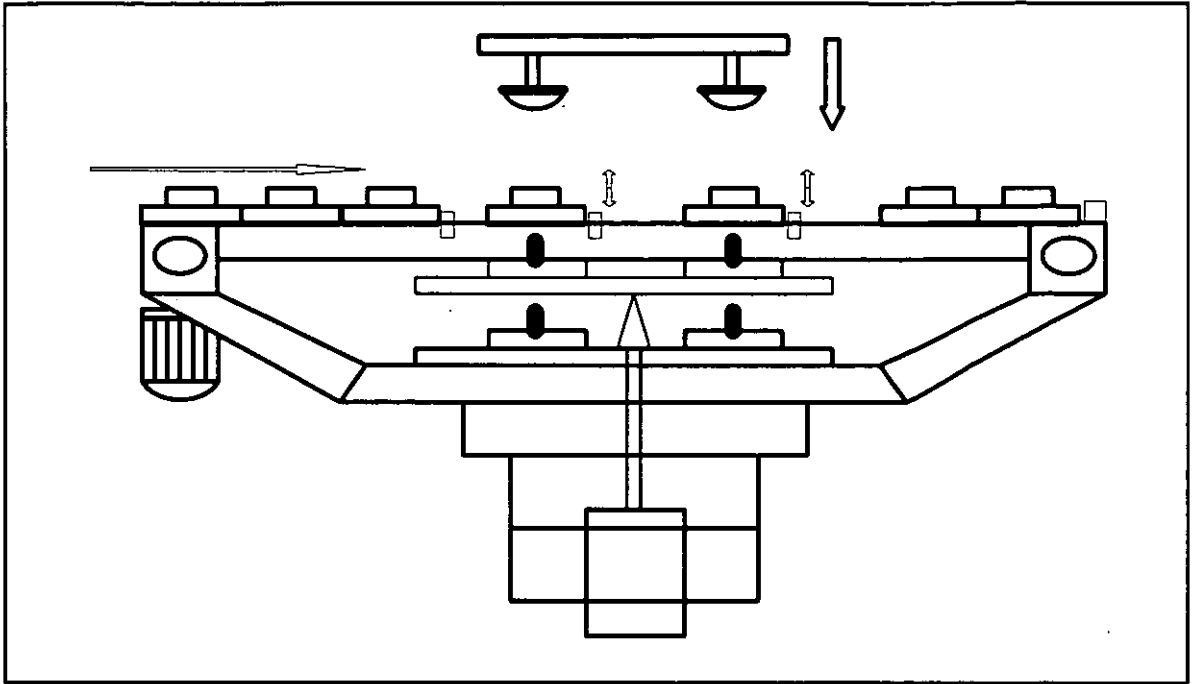

Figure 2.13: Possible solution to the conveyor approach.

New ideas on handling and positional accuracy were needed and one possible approach is shown in Figure 2.13. This idea itself has now been superseded in the light of current developments in Tampo Printing technology, and by having investigated the problem in greater depth. These ideas are discussed in greater detail in Chapter 7.

CHAPTER 3:
THE COMPONENT PARTS
OF THE CELL

3.1 SUMMARY.

This chapter will concentrate on a detailed explanation of the component parts of the proof-of-concept decoration cell and explain how the parts are linked in together. The reasons for the choices were explained in Chapter 2, therefore unless it is felt further explanation is required to clarify a particular point no reference will be made to the reasons why a particular component part was chosen.

The interfacing between the component parts is described along with the signals and status information. A description of the setup procedures for the Tampro print machines currently in use at Hornby Hobbies Limited is also included.

3.2 OVERVIEW OF THE PROOF-OF-CONCEPT CELL

The proof-of-concept cell currently consists of five major stations; 1) loading, 2) identification, 3) decorating, 4) inspection, 5) unloading. The sixth component is an overall cell controller



Figure 3.1: The Proof-of-Concept Cell.

which is at present being developed. This will take the operator through the start-up procedures and give information about incorrect settings or choices. It is also intended that this controller will also be used to take the operator through the teaching procedure with new models to optimise and speed up the operation.

The third function of the controller will be constant monitoring of the proof-of-concept cell during operation and to signal faults and bring the cell to a halt in an orderly fashion in the event of a fault.

There now follows a detailed description of the component parts of the proof-of-concept cell.

3.2.1 The loading station.

A chute loading mechanism was chosen as the input to the cell in the belief that this is the best representation of the method by which the undecorated bodysHELLS would arrive at the decorating station. The bodysHELLS on the chute would then slide by gravity into the cell loading area where they could be removed from the chute and be placed onto the workpiece carriers. After examining a number of ways for transferring the bodysHELLS from the chute the configuration chosen was a simple mechanism with two degrees of freedom, shown schematically in Figure 3.2.

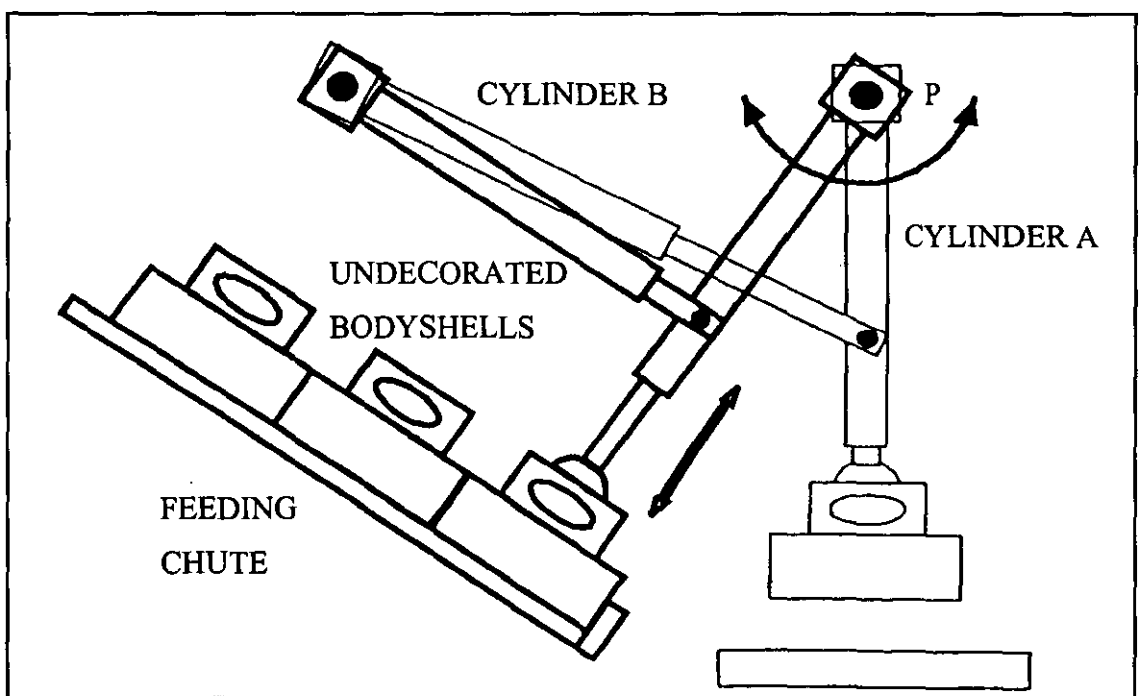

Figure 3.2: Principle of operation of the loading station.

In the rest position both cylinders are retracted. The operation of the mechanism is as follows: cylinder A is actuated positioning its end-effector (a suction cup) on the roof of the bodyshell located at the end of the feeding chute, the vacuum is actuated and cylinder A returns to the rest position lifting the bodyshell from the chute. The remaining bodyshells slide down so that the next one is positioned at the bottom of the chute. Cylinder B is then activated causing cylinder A to turn about its pivot point P. This movement places the bodyshell over the workpiece carrier, the vacuum is switched off and the bodyshell is deposited onto the workpiece carrier. The cylinders are returned to the rest position ready for the next cycle of operation.

The first design parameter to be calculated was the tilt angle of the chute that would enable the bodyshells to slide smoothly down it. The minimum value of tilt angle (Θ_{\min}) is calculated through Equation 3.1:

$$\Theta_{\min} = \arctan \mu \quad (3.1)$$

where: μ is the coefficient of friction between the bodyshells and the surface of the chute material.

The material chosen for the chute was aluminium. The value of μ between aluminium and plastic is approximately 0.25 which gives an angle Θ_{\min} equal to 14° . The maximum angle of Θ was determined experimentally. For angles greater than 40° the bodyshells would tend to tip over when they hit the bottom of the chute, therefore the tilt angle for the chute must lie between:

$$14^\circ < \Theta_{\text{chute}} < 40^\circ \quad (3.2)$$

The next step was to calculate the locations of the pivot points for the air cylinders and the length of the crank. These calculations took into consideration two important requirements:

- the angle of contact between the suction cup and the bodyshells had to be 90° in order for the suction cup to seal.
- the bodyshells should be released perpendicular to the surface of the workpiece carrier to guarantee that they would remain in an up-right position.

The definitions that follow refer to Figure 3.2. Let P_1 and P_2 be the points where the cylinders **A** and **B** are attached, θ is the angle of the chute and points **T** and **C** are the positions of a bodyshell over the workpiece carrier and at the bottom of the chute, K is the length of the crank and S is a line defined parallel to the crank K . The distance between line S and the crank K corresponds to the stroke of cylinder **B**.

A sensible way of reducing the number of variables is to impose constraints based on desirable design features such as having P_1 and P_2 aligned. This forces singular values on K , θ and d based on the properties of right angle triangles P_1, P_2, T and P_1, P_2, C' .

$$\text{From triangle } P_1, P_2, T: \quad d = (L_1 + L_2) \cos \theta \quad (3.3)$$

$$\text{From triangle } P_1, P_2, C': \quad a = \frac{L_1}{\cos \theta} \quad (3.4)$$

$$\text{By substitution:} \quad \theta = \arcsin \sqrt{L - \frac{1}{L_1 + L_2}} \quad (3.5)$$

Finally, the length of the crank is simply:

$$K = (L_1 + L_2) \sin \theta \quad (3.6)$$

The values of L_1 and L_2 are determined by the particular choice of air cylinder; they are the cylinder stroke and body length respectively. For the particular cylinder chosen $L_1 = 40$ mm and $L_2 = 165$ mm.

The value of θ calculated from Equation 3.5 is 26.21° and from Equation 3.6 the length of K is 91mm. From Equation 3.4 the distance d between the pivot points P_1 and P_2 is 184mm.

Having determined the parameters of the mechanism, the next step was to decide the method of fixing it by the conveyor. It was decided to fix it directly to the side of the conveyor structure

(Figure 3.3) utilizing the slots provided in the side of the conveyor framework. The base consists of three pieces, two side bars and a distance piece. The chute is long enough to hold ten bodysHELLs of the model¹ suggested as a trial model by Hornby Hobbies Limited and is supported between the support arms for the air cylinders by two brackets.

3.2.1.1 Mechanical adjustments.

The loading station can load various bodysHELLs provided that the following adjustments are carried out:

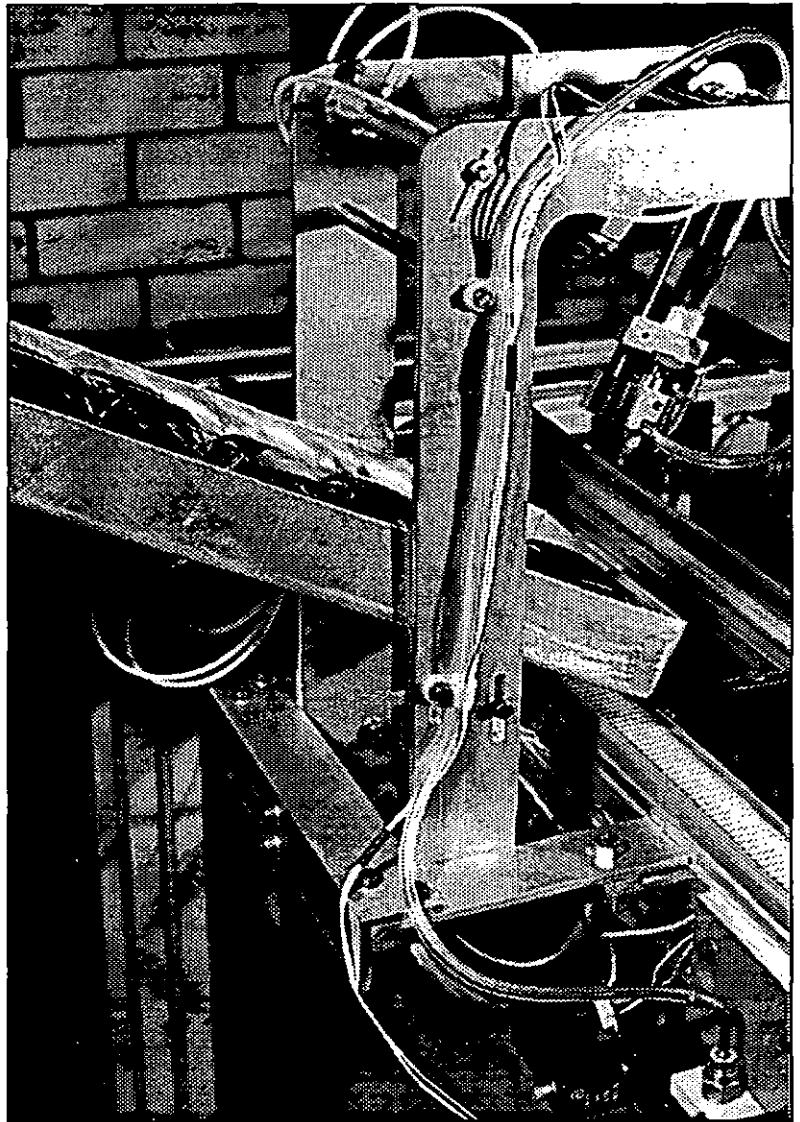

Figure 3.3: Side view of the loading station.

■ Replacement of the feeding chute; each bodysHELL has its own corresponding chute. Because of the modular nature of the base it is an easy job to insert a new chute and the corresponding distance piece.

■ Vertical adjustment of the chute; in order to accommodate bodysHELLs of different heights the chute can be adjusted vertically with the aid of slots in the support arms as can be seen in Figure 3.4.

The only sensing at this station is an opto-switch at the end of the loading arm which is used to

¹ Ford Sierra of dimensions 137 x 51 x 41 millimeters.

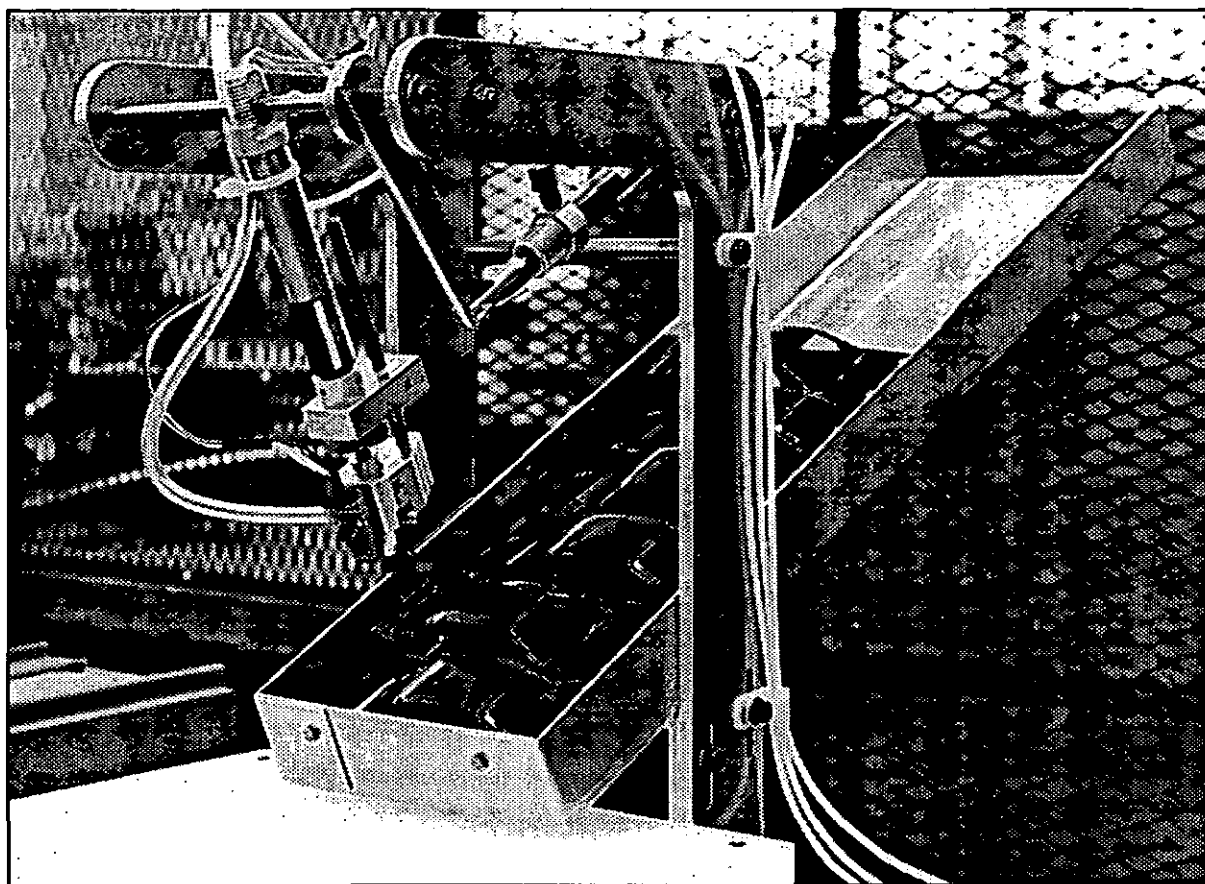

Figure 3.4: Front view of the loading station showing the adjustment slots for the chute.

check if there is a model on the chute and if it has been successfully transferred to the conveyor system.

The models are transferred from the loading station on specially adapted workpiece carriers that have a large perspex square on top of them. In the centre of the top face is a small perspex peg which is the only location for the bodysHELLs. This enables any bodysHELL (car or train) to be carried without the need to resort to special adaptors.

3.2.2 The identification station.

The identification station consists of two main parts, the **side-lighting arrangement** and the **pick up mechanism**. The basis of the side lighting arrangement was described in Section 2.3.1 and only the mechanical adjustment will be described here. As previously stated the pick up mechanism is a PUMA 562 series robot.

3.2.2.1 Mechanical adjustment.

It was verified experimentally that the light distribution through the perspex block was not uniform when the reflectors of the bulbs were positioned parallel to the sides of the block. This is shown in Figure 3.5. The illumination measurements were taken with an exposure meter and then converted.

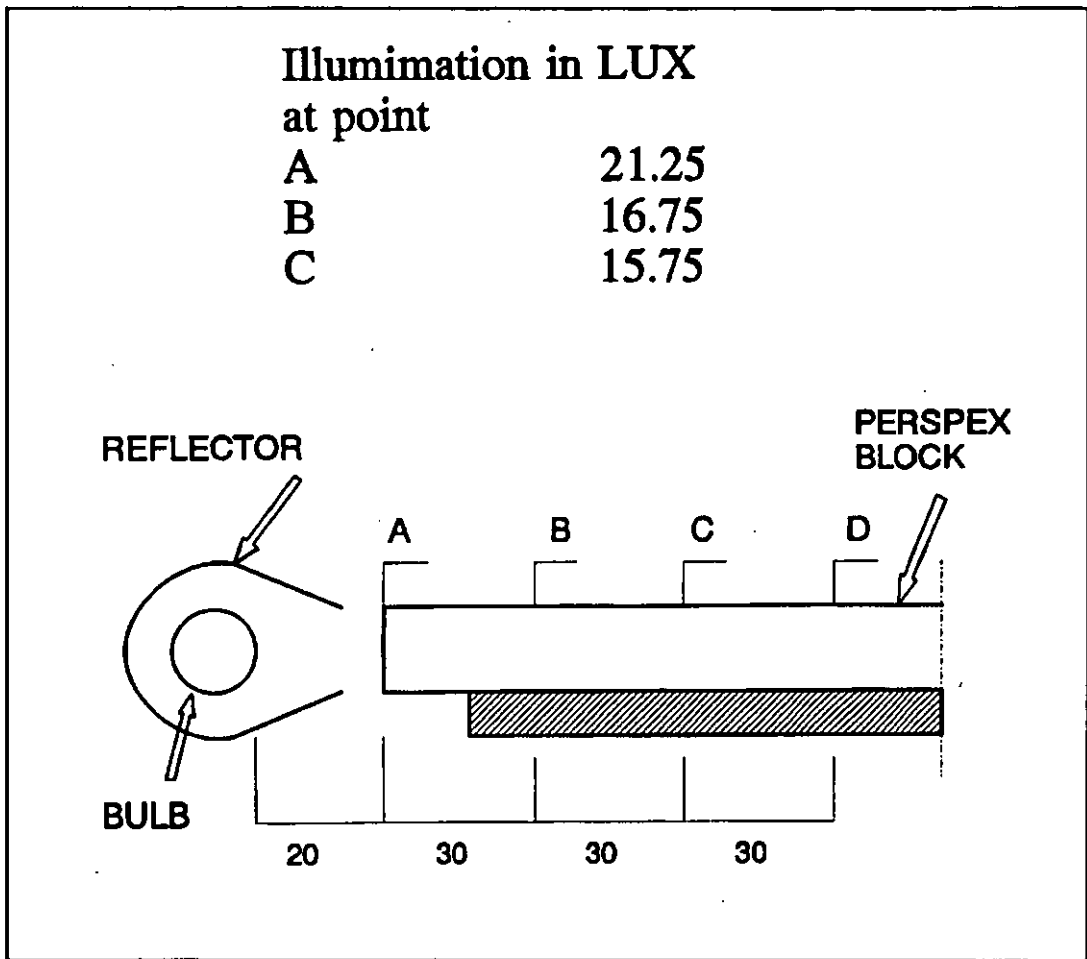

Figure 3.5: Light distribution through the perspex block.

It was also verified experimentally that the non-uniform distribution of light through the perspex affected the reliability of some pattern recognition functions of the vision system. Therefore, a means of inclining the reflectors in relation to the perspex was required in order to obtain a more even distribution of light throughout the block.

The ideal angle of the reflectors would be the angle which caused total reflection of the light on the bottom surface of the perspex, the total reflection angle, which can be calculated by the law of refraction, also known as Snell's Law. The total reflection angle depends only upon the

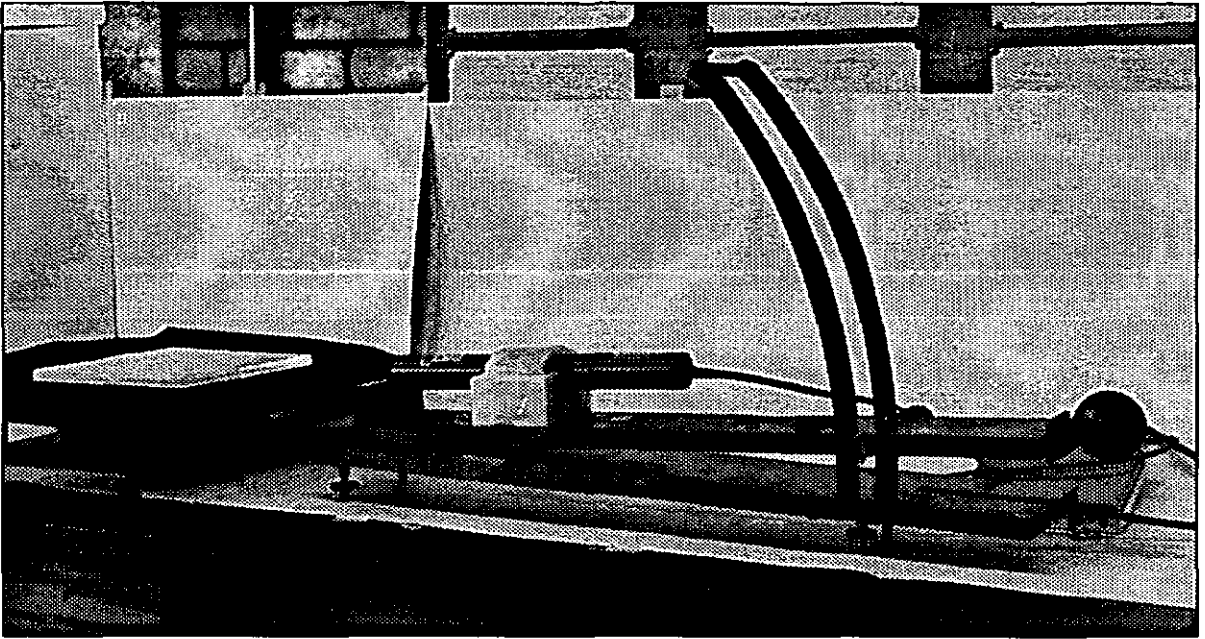

Figure 3.6: Apparatus used for determining the total reflection angle of the perspex block.

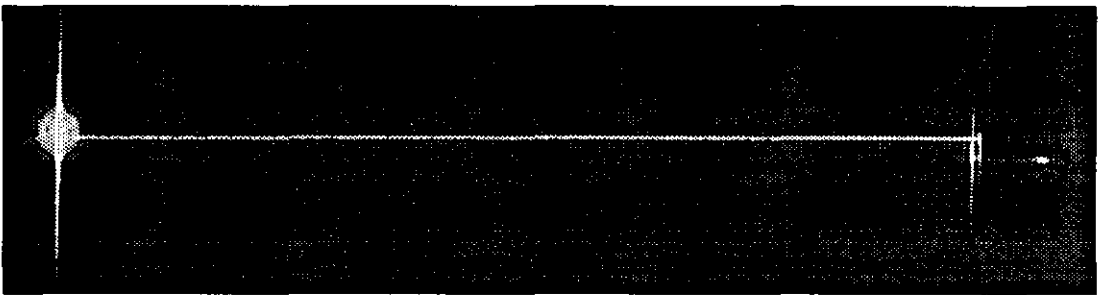

Figure 3.7(a): Perspex block lit by a 5 mw Helium Neon laser at 0° .

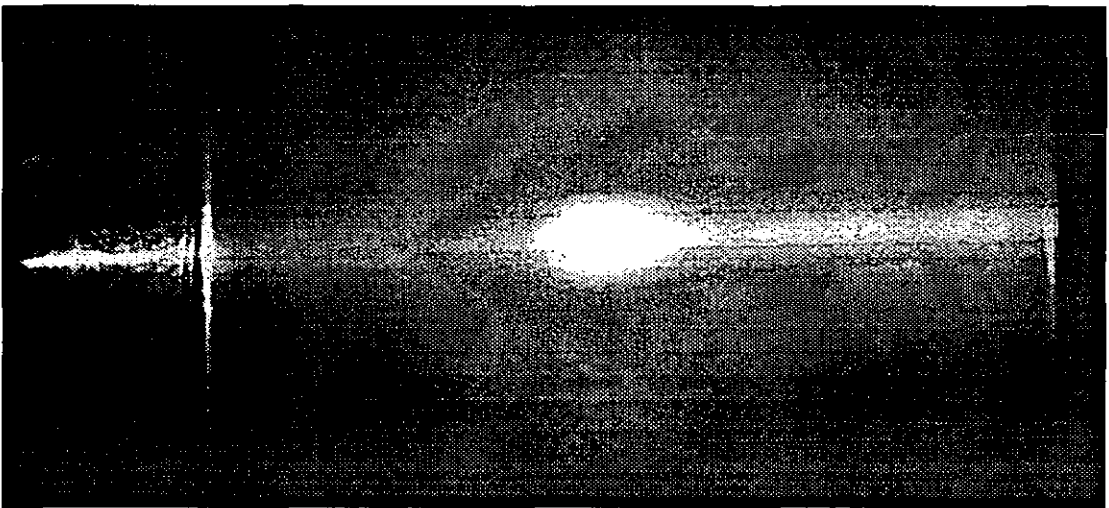

Figure 3.7(b): Perspex block lit by a 5 mw Helium Neon laser at 6° .

index of refraction where the light is directed to. For perspex this is 1.492 {Kaye, 1973}. However, because the bottom surface of the block was treated this index would not be true and the total reflection angle would have to be determined by experimental means.

This was done by simply mounting a low power laser onto an adjustable mechanism and pointing it at the perspex block (Figure 3.6), and noting the angle which produced the most intense light reflection on the top surface of the perspex block. Figure 3.7 shows two examples of the perspex being lit by the laser at 0° and 6° , the latter being defined as the total reflection angle.

The angular adjustment of the side-lighting system is shown in detail in Figure 3.8. The tilting mechanism is adjustable between 4° and 8° to compensate for the diffusion of the light when the laser is replaced by tubular bulbs.

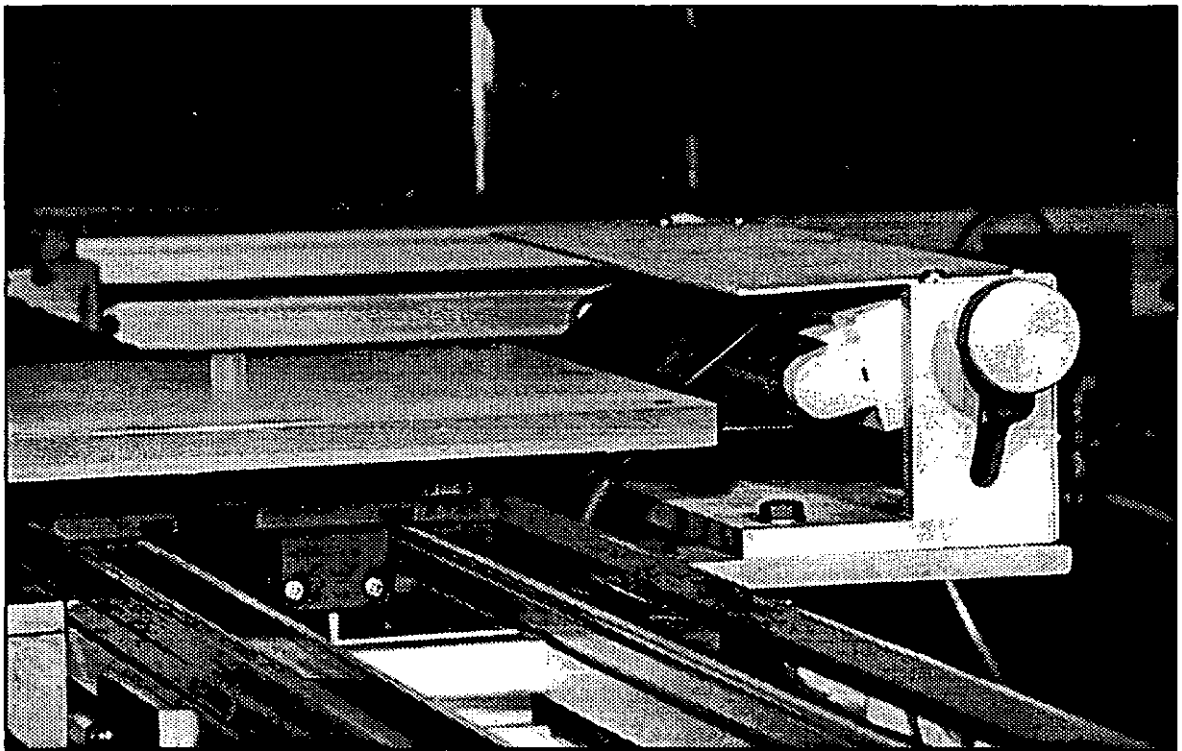

Figure 3.8: Angular adjustment of the side-lighting mechanism.

3.2.2.2 *Electrical adjustment.*

A very common phenomenon in image acquisition is the saturation of the camera. This occurs when the intensity of the light in the field of view exceeds a certain limit and as a result any

output from a vision system which operates with that camera is meaningless.

Unfortunately camera saturation was an observed side effect of the side-lighting system. In order to overcome this problem the voltage applied to the light bulbs is controlled via a voltage regulator, and in consequence, so is the intensity of the light shining into the perspex block.

3.2.3 Information required from the identification station.

When the workpiece carrier reaches the identification station the camera mounted on the PUMA robot arm is used to analyse the workpiece carrier and its contents. The particular questions that the machine vision system has to find answers to are:

- Where are the reference marks on the workpiece carrier?
- Is there a known object on the workpiece carrier?
- What bodyshell and colour is it?
- Where is the centre of boundary?
- What is the orientation angle?

The answer to the first question is needed to check the alignment of the workpiece carrier with the reference frame (see Section 3.5) and to check that the camera is in the correct position by measuring the distance between the reference marks. If the measurement between the reference marks is wrong it indicates that the camera is not the correct distance from the workpiece carrier. If this is so then the object under scrutiny will not be recognised by the vision system as the measurements will not match with those of the reference object.

The answers to points two and three will reject the object if it is not in the library of known shapes or not the right bodyshell for the present decoration set-up, while the answers to four and five will be sent to the robot controller to update the model reference location so that the bodyshell can be grasped safely. To pick the bodyshell from the workpiece carrier a suction gripper is employed which has sensory feedback in the form of four optical switches.

This feedback is essential because of the problems experienced with viewing a 3-D object with a 2-D system in that the centre of boundary appears to “move” depending upon the orientation

and position of the object. The pick point for the car being used in the proof-of-concept cell is near the front of the roof and parallax error can move this preventing the suction gripper from working properly. Should this happen signals from the sensors arranged around the suction gripper are used to instruct the robot to move so that the gripper is over the centre of the roof. This means that the current grip point is no longer the centre of boundary of the bodyshell and so a method of re-positioning has to be used so that the correct pick point can be located again (Figure 3.9).

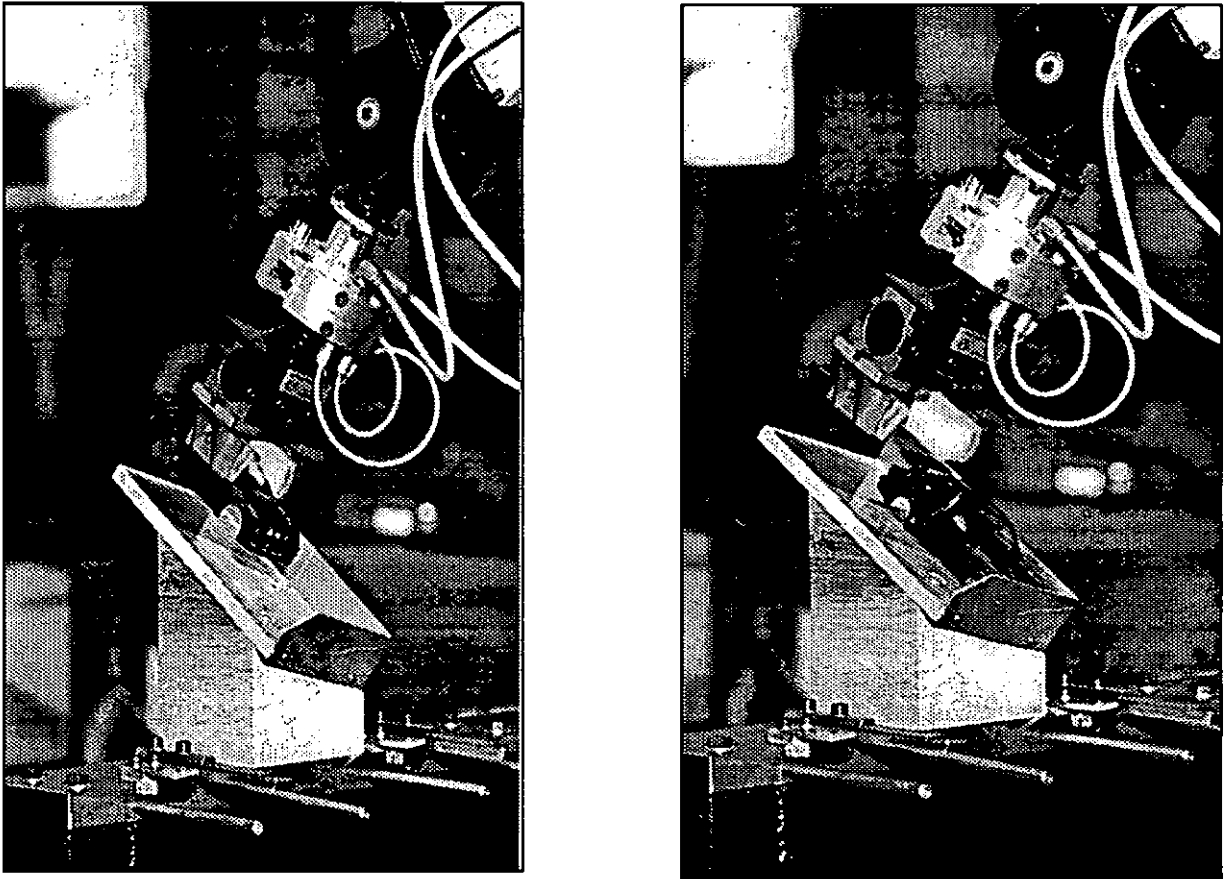

Figure 3.9: The principle of operation of the repositioning device.

This operation is essential as a special printing block called a matrix is needed to prevent the bodyshell from deforming during printing. The matrix is an exact mould of the bodyshell and therefore the bodyshell has to be positioned with great accuracy to prevent damage or jamming.

3.2.3.1 Re-positioning device.

As can be observed in Figure 3.9 the re-positioning device is extremely simple. It is also very reliable as the bodysells always end up aligned against the sides of the device, they simply slide by gravity along the bottom surface of the device.

The material of the bottom surface is perspex and the angles of the stand were calculated through Equation 3.2, μ in this instance is the co-efficient of friction between plastic and perspex. The top surface is initially inclined at 31° relative to the horizontal and then by 21° relative to the bottom left corner (Figure 3.10). It is worth mentioning that the re-positioning device also cancels out any errors from the robot-vision calibration procedures and the vision system measurement routines.

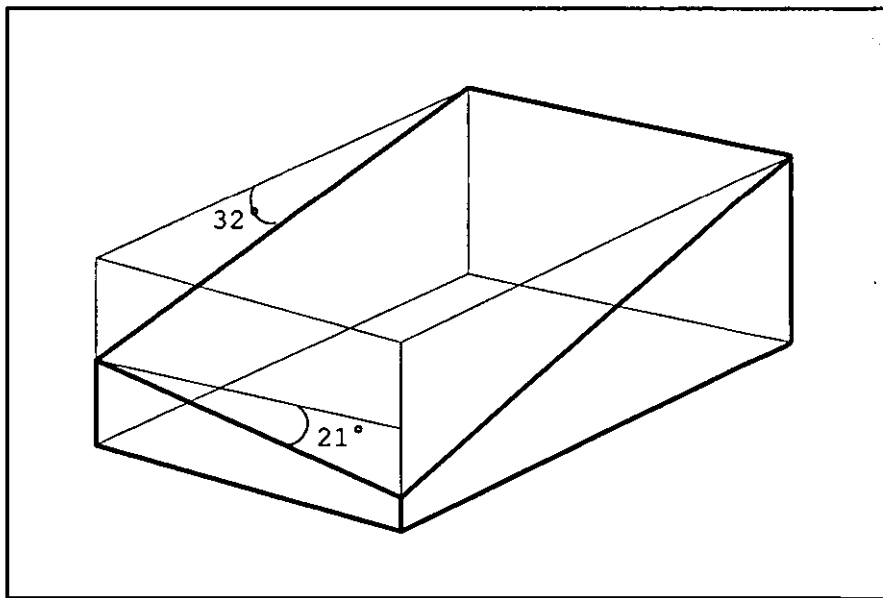

Figure 3.10: The inclination angles of the repositioning device.

The necessity for using the re-positioning device was arrived at after evaluating the effort required to cancel out the optical illusion error by software or electronic means. In some mechatronic products one can identify the integration between the three fields as a way of aiding the achievement or simplification of the mechanical requirements of the product, viz the autofocus camera. In the re-positioning device however, this trend is broken as any other method would be extremely difficult to carry out.

3.2.4 Decoration station.

The decoration station is in two parts: **tool changer** and **tampo print machine**. The tool changer is required because the robot has to pick the bodyshell from the workpiece carrier and transfer it to a matrix. The matrix then has to be taken to the tampo print machine.

3.2.4.1 Tool changer.

The tool changer presently used in the decoration station (Figure 3.11) was designed and built as a final year student project {Roach, 1989} and has since been modified to allow it to work successfully within the proof-of-concept cell. The modified tool changer still exhibited certain operational difficulties and in consequence a new mechatronic tool changer was developed (Figure 3.12) to overcome these difficulties. The underlying idea behind the mechatronic tool changer was that it should be possible to unlock/lock the different end-effectors anywhere within the robot

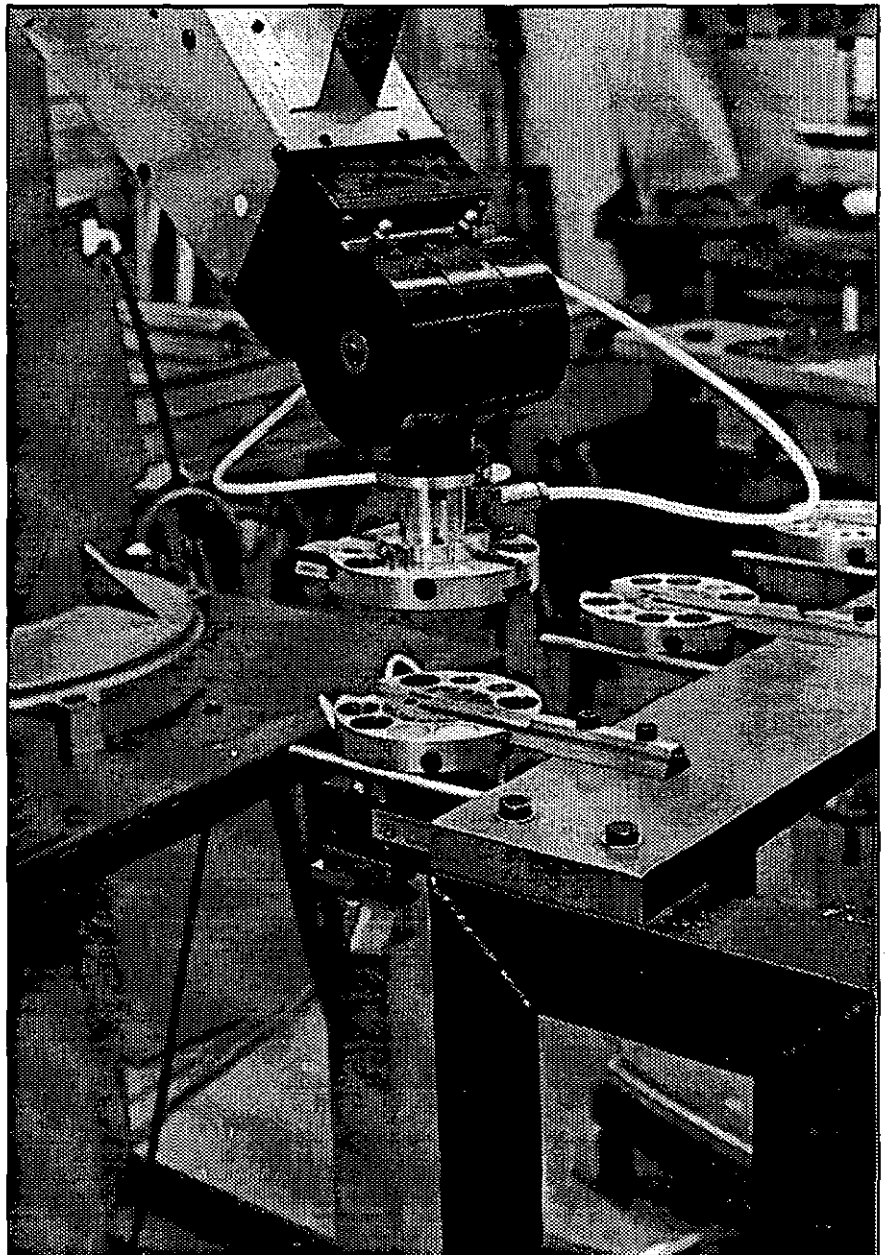

3.11: The original tool changer.

should be possible to unlock/lock the different end-effectors anywhere within the robot

workspace and not have to continually return to a tool rack to change end-effectors.

This need came about through the development of ideas whereby the matrices are loaded onto a conveyor system in front of the printing machine (see Chapter 7).

3.2.4.2 *Tampo print machine.*

The aim is to find the best mechanical interaction between the pad printing machine and the PUMA robot in order to carry out the efficient decoration of the bodysHELLs.

Examining the operation of the pad printing machine it would be very difficult to automate in any other way the present inking operation as the sweeping of the ink over the cliché, and then wiping the excess away is basically

a straight single plane action. It can also be argued that by using the present pad printing machine, it would be difficult to improve on the method of actually printing the bodysHELL. Therefore, the area left for improvement is that of handling the bodysHELLs in front of the pad printing machine.

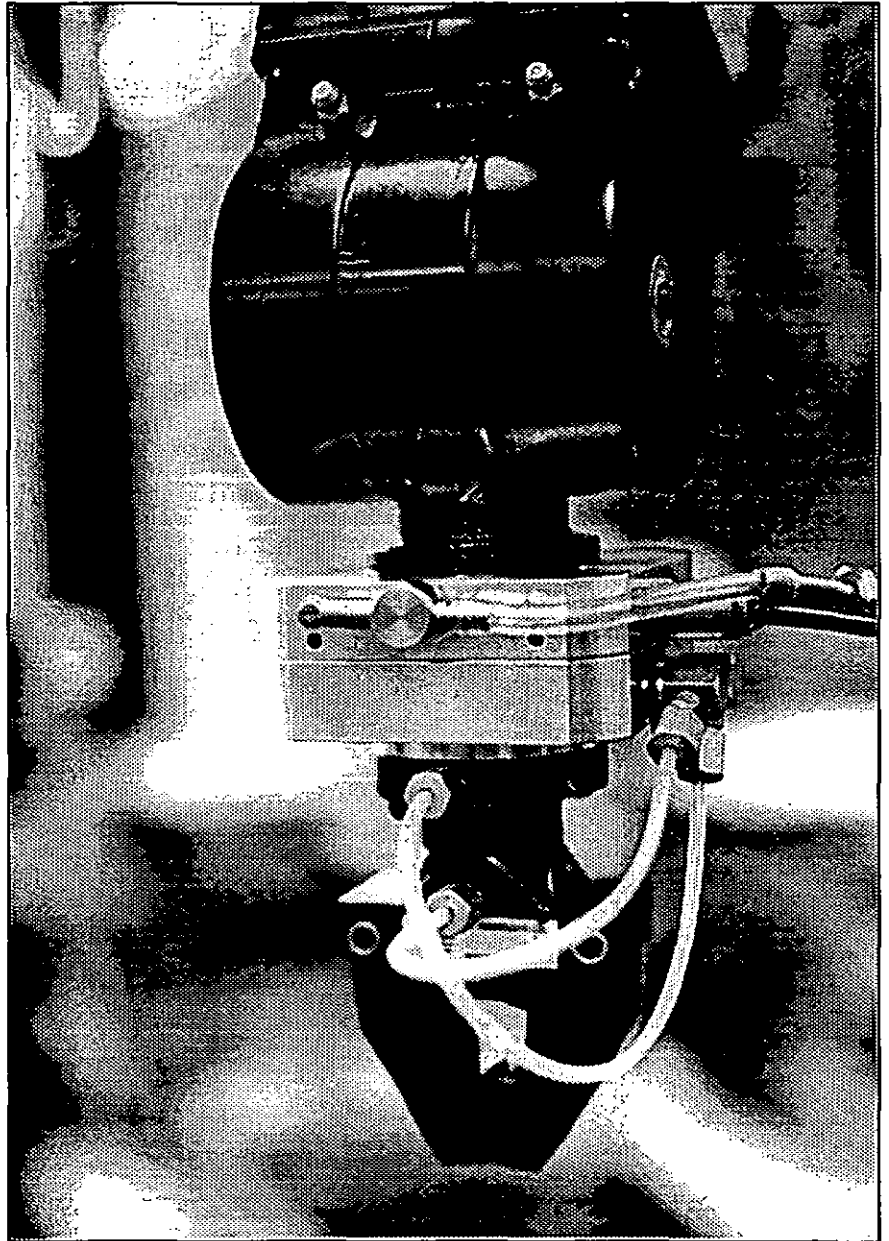

3.12: The mechatronic tool changer.

The main mechanical requirement is that the matrix should always be placed accurately under the silicone pads. Another requirement, and one none the less important, is that there should be room for the service personnel to be able to set the machine up for each decoration. There are a number of potential solutions to the problem and those that were tried are reviewed in section 3.4. These ideas have led to a the possibility of a completely new design of pad printing machine that will be outlined in Chapter 7.

3.2.5 The inspection station.

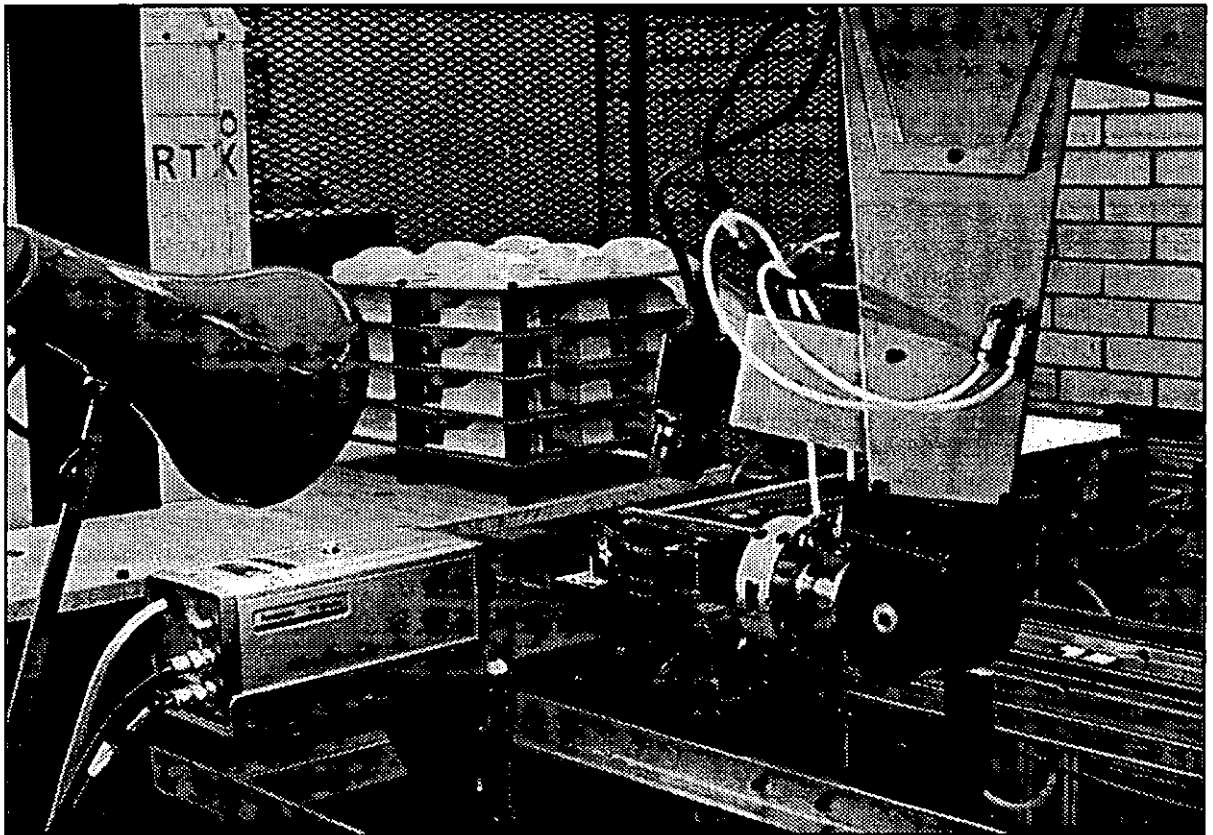

Figure 3.13: The inspection station.

Inspection is carried out automatically by the machine vision system at a custom designed inspection station (Figure 3.13). The final version will consist of a frame with 3 cameras and three lamps. A locating device similar to that at the printing machine is utilised. Each car is divided into three sections (front, middle and back) and the robot positions the matrix/bodyshell on the locating device so that each section can be inspected in turn.

There are reference marks on the matrix and these are used to check the location of the matrix

as well as the positional accuracy of the decoration on the bodyshell. The decorations are also checked for completeness and colour. The bodyshell will be rejected if any of these three items is wrong, likewise, if the printing machines have been set up with the wrong decorations then this will also cause the bodyshell to be rejected as the database will not recognise these as correct for this particular model.

This 'failure' information will eventually be made available to the decoration station so that corrective action can take place.

It is worth mentioning the problem with focusing the cameras when inspecting the roof, bonnet and rear of the car. The problem arises because these areas are different distances from the camera and because of the short focal length of the lens used they cannot all use the same focus setting. Using an autofocus lens is one solution but this is very costly. A cheaper a more mechatronic method would be to use a mechanical adjustment on the camera frame so that the camera was moved relative to the model.

The lights used at the inspection station are standard domestic clip-on spotlights with 25 watt bulbs. Using higher power bulbs can cause 'flare' on the bodyshell and hence cause problems with the inspection.

The present design concept of the inspection station is that it will be used to inspect fully decorated bodyshells, but there is no reason why partially decorated bodyshells should not be inspected either after each decoration operation or to check the printing machine set up. Bearing in mind the original overall concept of utilising up to seven tampon print machines to decorate the bodyshells, then for partial inspection after each operation an inspection station will be required after each machine hence increasing the cost considerably but on the plus side allowing defects to be spotted earlier in the decoration cycle.

3.2.6 The unloading station.

Models that pass inspection have to be transported to assembly, or storage in the case of the present factory working method. Presently the completed bodyshells are wrapped in tissue paper to prevent damage and then packed in cardboard boxes before being taken from the decoration area.

This method has three distinct disadvantages;

- a) it is very labour intensive,
- b) any orientation knowledge gained during the decoration cycle is lost
- c) it is very costly in terms of tissue paper.

Therefore any automated system must be capable of;

- maintaining orientation
- preventing damage
- ease of transportation and storage

3.2.6.1 The matrix/pallet concept.

A very simple way of maintaining orientation is to use trays which have hollows into which the goods are placed, this also has the added advantage of preventing damage to the goods by preventing them moving around. An easy method of moving trays of goods around is to palletise the trays. Therefore by carefully defining the problems associated with handling the decorated bodysHELLS a sensible solution presented itself.

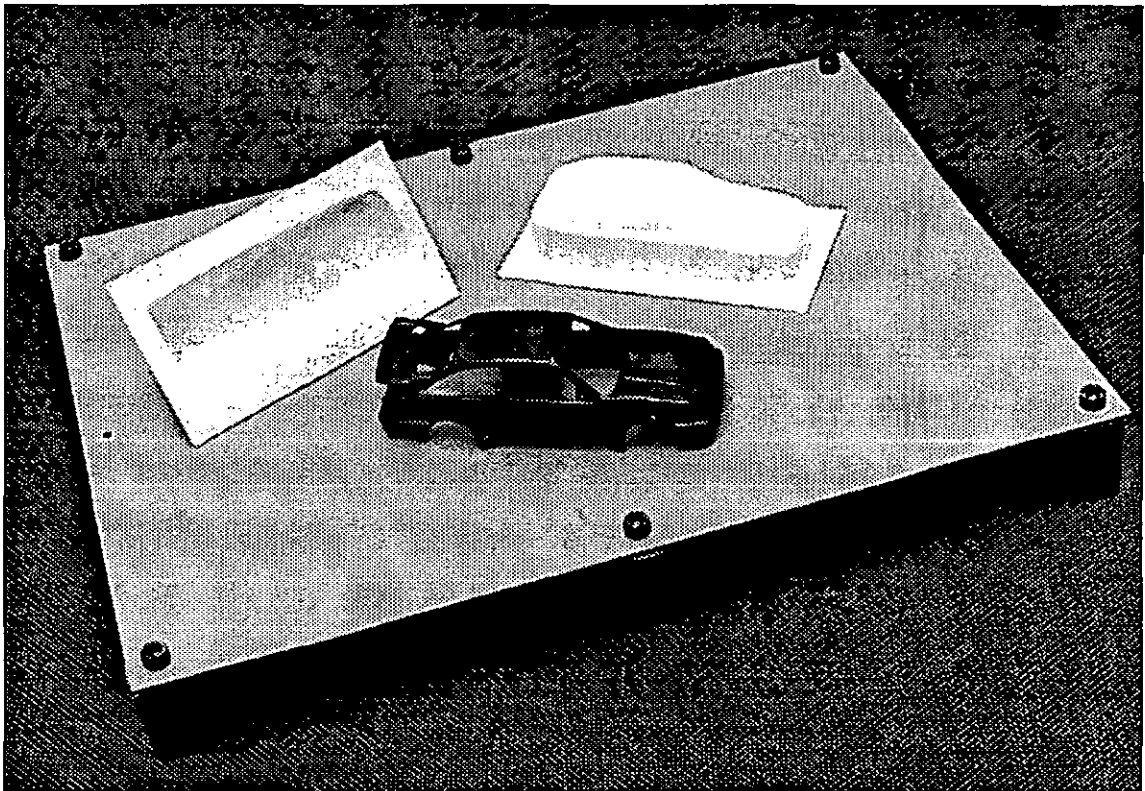

Figure 3.14: The component parts of a pallet.

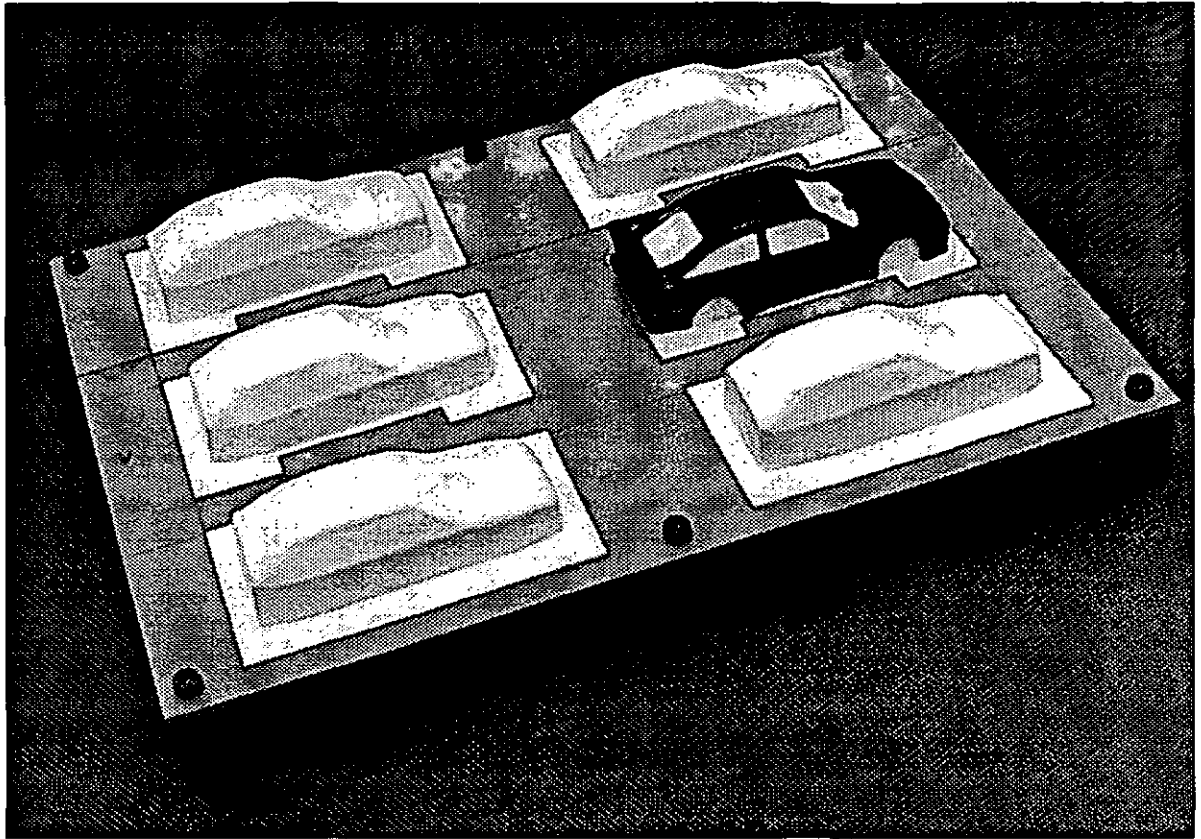

Figure 3.15: An assembled pallet.

In this case instead of using a hollow tray it was decided to use a tray with a raised hollow matrix. Hornby Hobbies were asked if they could manufacture the trays to our design and initially they were in agreement, but problems with the vacuum moulding meant that they were actually made as individual hollow matrices (Figure 3.14). Hornby Hobbies also provided separate bases onto which the hollow matrices could be stuck in groups of six (Figure 3.15).

The size of the base is 20 cm x 30 cm and the overall height is 9 cm. The complete pallet weighs 0.850Kg.

3.2.6.2 The 'H' shaped suction end-effector.

With the matrix/pallet concept, there are two distinct actions that have to be performed by the RTX robot:

- a) it has to transfer a pallet from the stack of empty pallets to where the bodyshells will be loaded onto the pallet

b) it has to transfer the bodysells from the inspection station to the pallet if it has passed inspection or to reject/rework if it is has not.

Because of the serious limitations of the RTX in terms of repeatability and programming², the use of a tool change mechanism was ruled out. This led to the design of the dual purpose end-effector shown in Figure 3.16.

It consists of an H shaped plate with five suction cups attached to it, one in the centre and one at the end of each of the four 'arms'. The central cup is used to carry the bodysell and the others for transporting the pallets. Figure 3.17 shows the RTX performing these two distinct actions.

The solution for transferring the bodysells from the inspection station to the unloading station was found by causing the work areas of the PUMA and RTX robots to intersect at one point. Therefore, it is possible for the RTX robot

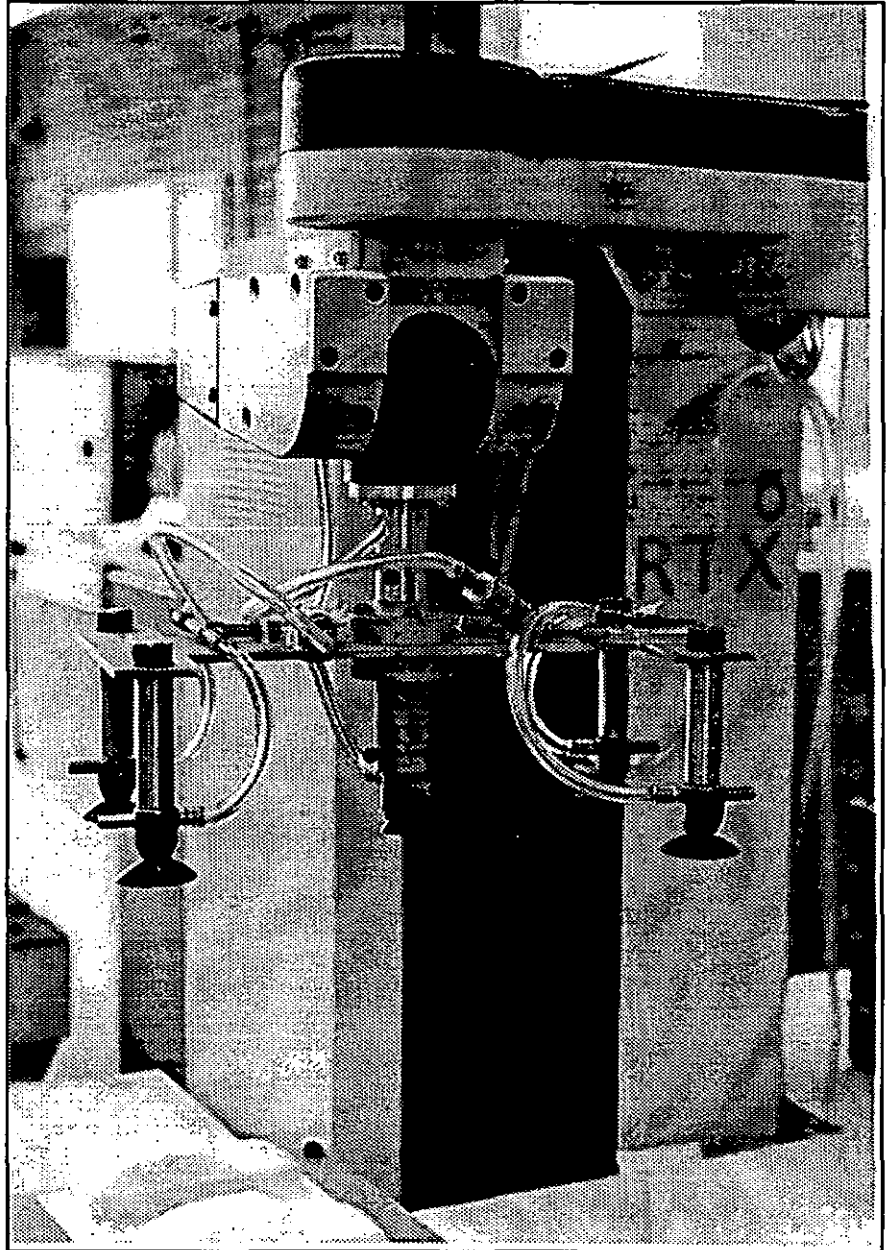

Figure 3.16: The 'H' section end-effector used on the RTX robot.

² Joint level programming.

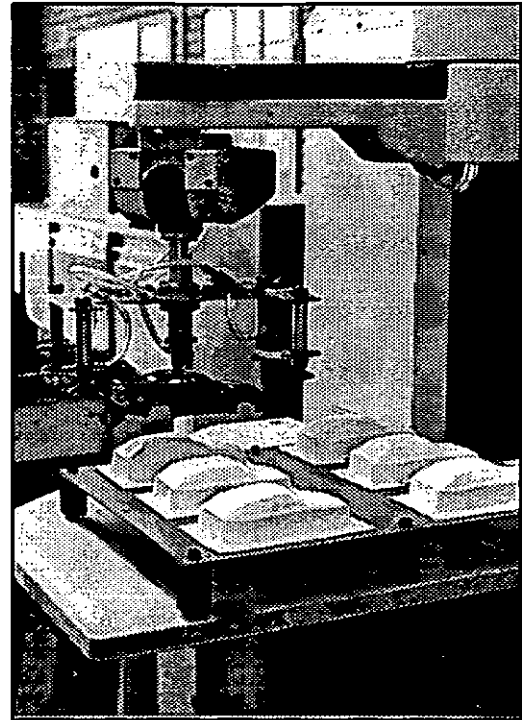
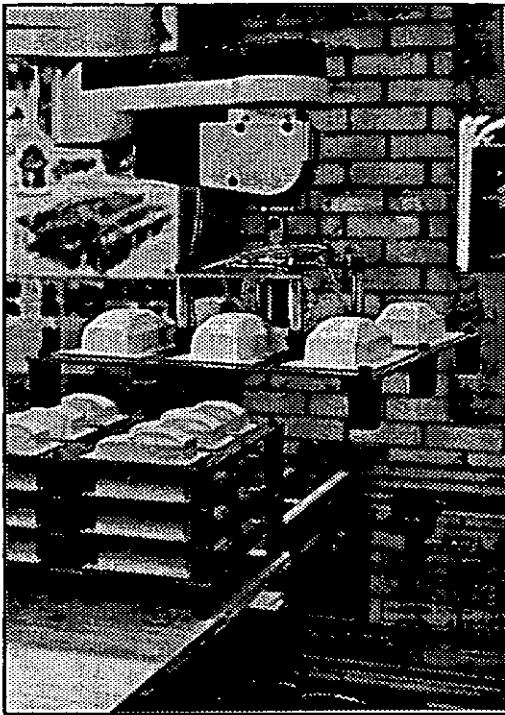

Figure 3.17: The two actions performed by the 'H' section end-effector.

to remove the inspected bodyshell directly from the matrix end-effector of the PUMA robot. This simple solution can be thought of as a mechatronic alternative to that of having an extra mechanical link between the inspection and unloading stations. It only requires simple software routines to implement the changeover.

3.3 THE TAMPO PRINTING MACHINE.

The major feature of the decoration process in use at Hornby Hobbies Limited is the use of open ink well Tampo print machines. These are very costly in terms of man hours to set up and waste due to evaporation of the thinners, but until comparatively recently these were the only types available.

For this reason it will be instructive to follow the procedures necessary to put one of these machines into an operational state. It must be remembered that these procedures have to be gone through for each decoration setup, and there are seven machine changes required³, with a scheduled setup time of three hours each time therefore the machines are effectively idle for

³ For the Ford Sierra used as a trial model.

three single shift days during the production of this bodyshell. The other important point that has to be remembered is that each machine has to be cleaned down after the last shift and reset ready for the first shift the next day. Therefore it really comes down to at least 3 man hours/shift not per operation.

3.3.1 Setting up.

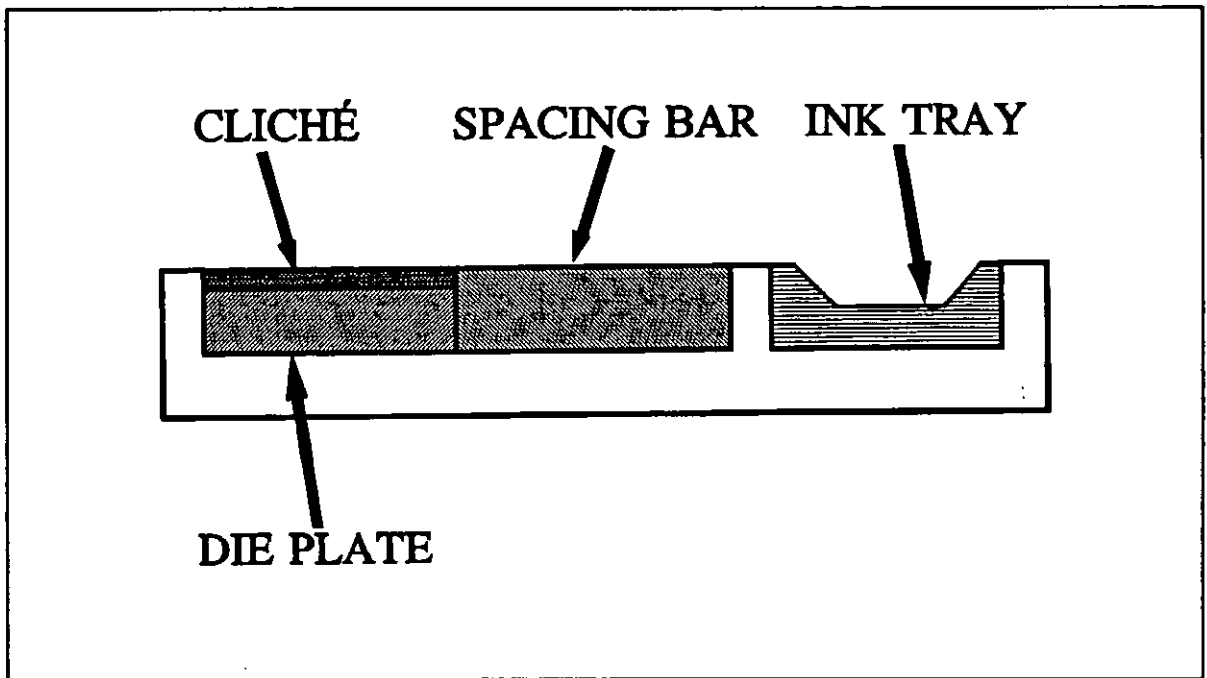

Figure 3.18: Fitting the cliché onto the die plate.

The first operation is to fit the printing plate (cliché) onto the die plate (Figure 3.18) ensuring that it is level with the surface of the spacing bar. Failure to do this could result in the doctor blade and/or spatula catching on either the cliché or spacing bar and causing damaging to one or all of them. Ink must now be mixed and added to the well at the rear of the machine. This is the first of many 'black arts' associated with the system as the precise mix of paint and thinners depends on many variables. Ambient conditions and print area being just two. If more than one colour is required then separators are fitted into the ink tray.

With reference to Figure 3.19, stage two of the setting up procedure is to fit the Ink Unit (a) onto the printing machine, attach the tampons (printing pads) (b) to the Pad Mounting Plate (c) and fit them into the Pad X,Y Holder Unit (d) on the machine. The doctor blade and spatula (e) are then fitted onto the Doctor Blade Mechanism Holding Bar (f) and the machine started up so

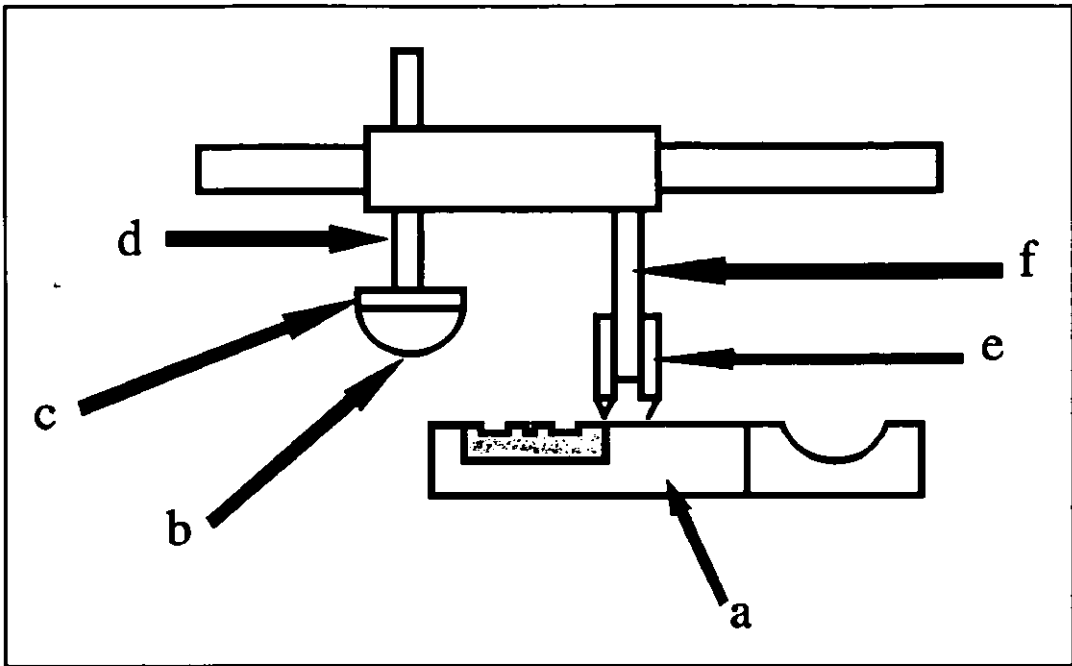

Figure 3.19: The component parts of a Tampo Printing Machine.

that the doctor blade can be adjusted to clean the cliché properly. This sounds easy but in fact there are 38 separate adjusting screws on the doctor blade plus five possible air pressure/movement adjustments to be made. Even skilled operatives can spend almost one hour on this operation alone.

During this operation the ink consistency is almost certain to require adjusting many times to retain, or even modify, the original 'specification'.

Having obtained a satisfactory sweeping/wiping operation the next stage is to fit the matrices (f) onto the worktable (g) at the front of the machine, this currently is a very hit and miss affair as no proper jiggling exists at the factory to achieve this. After fitting, the machine is restarted and the tampons and matrices are adjusted so that the decoration is placed in the correct position on the model.

Again more adjustment of the ink consistency will be called for along with frequent cleaning of the tampons.

The tampo print machine is now ready for use after approximately 3 hours of setting up time. In this period it would have been possible to decorate maybe 1500 cars, not fully but at least

with one 'set' of decorations, had a better system been in use and the machines capable of continuous operation.

3.4 INTERFACING BETWEEN COMPONENTS.

There are four main control units employed in the proof-of-concept cell;

- PLC⁴ for the conveyor system
- MX Magiscan for the vision system
- VAL II controller for the PUMA
- Victor PC for the RTX robot.

3.4.1 Loading station.

The PLC is interfaced with the loading station, the inspection station and the PUMA controller. When a workpiece carrier arrives at the loading station a signal is sent to the PLC to operate the loading mechanism to place a bodyshell onto the workpiece carrier. The sensor beside the vacuum cup on cylinder A (Figure 3.2) informs the PLC if there is no bodyshell ready or if the transfer was not completed correctly. If the transfer was successful the workpiece carrier is released to carry the bodyshell round to the identification station. The lack of a bodyshell or an incorrect transfer will signal an error, which at present requires manual intervention.

3.4.2 Identification station.

When a workpiece carrier arrives at the identification station the PLC sends a signal to the PUMA controller that a workpiece carrier is waiting. When the PUMA arm is in the 'photograph' location and the 'workpiece carrier waiting' signal is active then the PUMA controller sends a signal to the PLC to switch on the lights in the identification station. The MX controller is then instructed to take a photograph of the workpiece carrier and its contents. After a pre-

⁴ Programmable Logic Controller.

determined time a signal is sent to the PLC to turn off the lights.

After the MX controller has analysed the picture the object on the workpiece carrier is either accepted or rejected. Depending on the reason for the rejection, at this stage manual intervention may still be needed. If the object on the workpiece carrier is accepted then information regarding its position and orientation on the workpiece carrier is sent to the PUMA controller. This information is then used to update the reference location of the object and the robot is then driven to pick up the object.

3.4.3 Decorating station.

Some of the front panel controls on the tampo printing machine are duplicated in software in the PUMA controller and along with some additional switches these provide the necessary timing to ensure that the PUMA presents the matrix/bodyshell to the tampo printing machine at the correct time in the print cycle. The only other signal information from the decorating station is the status of the tools on the tool changer, this will be used when the cell starts up to check which tools are fitted onto what rack on the tool changer and to check that they are correctly located.

3.4.4 Inspection station.

When the PUMA robot places the matrix/bodyshell at the identification station the PUMA controller sends a signal to the MX controller to photograph the bodyshell. If the reference marks on the matrix are not in the correct positions the MX controller sends a signal to the PUMA controller to reposition the robot. After the matrix has been successfully positioned the MX controller sends further information to both the PUMA controller and the RTX controller concerning the results of the inspection routines, this at present is simply in the form of pass or fail. Routines are being written to output more specific data regarding failure information which can then be used in an analysis of the proof-of-concept cell performance.

3.4.5 Unloading station.

The only other interaction between the unloading station and the PUMA controller is when the PUMA robot reaches the 'change over position' and a signal is sent to the RTX controller to remove the bodyshell from the matrix. When this operation has been completed a signal is sent from the RTX controller to the PUMA controller to inform it that the cycle can start over again.

CHAPTER 4:

**THE SOFTWARE USED IN
THE CELL.**

4.1 SUMMARY

This section describes the software of the proof-of-concept cell. It is not the author's intention to reproduce all of the programmes written, but rather to give an overview of the general structure of the software and the interaction between the different programmes. In places part of the code is given to either clarify a point or to make it easier to follow the reasoning.

One inescapable fact is the number of different languages used in the cell as shown in Table 4.1.

Table 4.1: The various high level languages used in the proof-of-concept cell.



STATION	LANGUAGE
Loading	PLC mnemonic code
Identification	MS-Pascal and VAL II
Decoration	VAL II
Inspection	MS-Pascal and VAL II
Unloading	Forth and VAL II



Obviously it was not a deliberate ploy to use such a disparity of languages. Rather these languages come as standard with the various component parts of the cell. It just shows the diversified range of languages that have to be mastered when integrating a range of standard equipment.

The software to generate the pattern recognition database was written in Microsoft (MS) Pascal as this was the language used by Joyce-Loebl to write the code for the Magiscan Vision System. To make full use of the procedures already available in the vision system library however, a knowledge of the structure of the vision system is also called for. This will be reviewed

briefly in section 4.3.

4.2 SOFTWARE SYNTHESIS.

4.2.1 Loading station.

The control of the loading station is via the PLC. This section gives the PLC code for controlling the stop/release gates on the conveyor system at the loading station as well as the control of the loading mechanism itself.

In addition to the proximity switches and solenoid valves used for controlling these actions, two more switches and valves are shown in Figure 4.1 as a means of starting and ending this section of code.

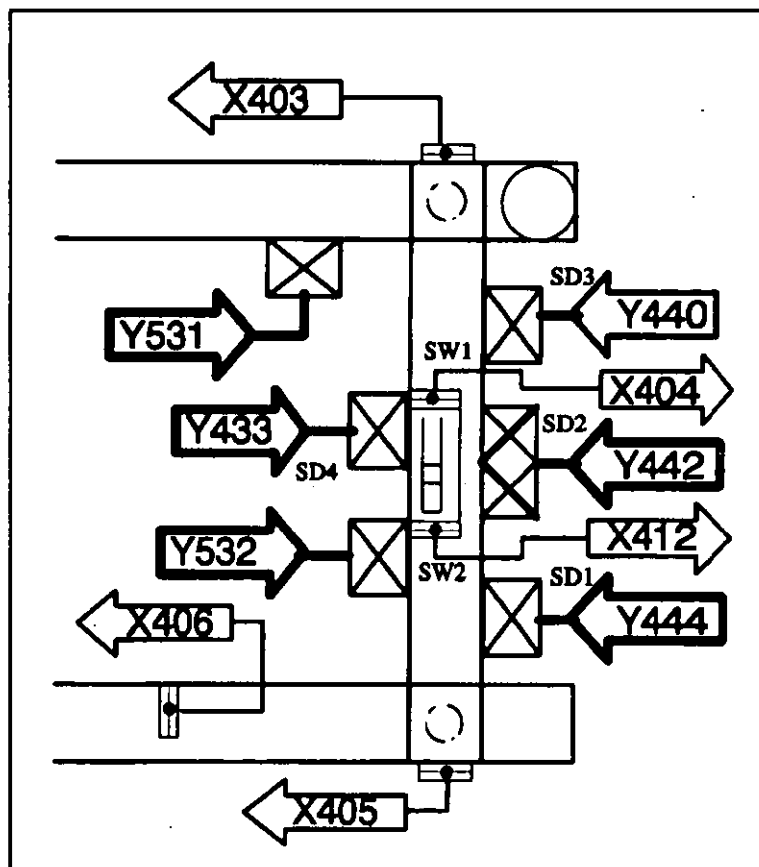

Figure 4.1: PLC input/output allotment at the loading station

In Figure 4.2 the X's represent the signals which are loaded into the PLC, Y's the outputs from the PLC to the various valves and M's the internal relays used for setting up the clock registers represented by T's. Refer to lines 5 and 6 for setting up clock T450. This pattern is repeated for the other three clocks. These are used to implement a delay of 1.0 second between the various actions of the loading mechanism.

The PLC is programmed via a set of 22 basic instructions in its own mnemonic code. Examples are LD (LoaD), LDI (LoaD Inverse), S (Set), R (Reset), OUT (OUTput), AND (AND) and so on. For the complete set refer to Mitsubishi {1987}. After allotting the input/output numbers to the various sensors and actuators to be controlled by the PLC the programmer has to write a flow chart and then convert this into the mnemonic code. This is best expressed as a ladder diagram. The section of code shown in Figure 4.2 contains the commands for stopping and releasing the workpiece carrier as well as the control of the loading mechanism.

14	LD	[X403]	ANI	[X403]	S	[Y531]
17	LD	[X404]			R	[Y531]
					S	[Y444]
					S	[Y440]
					S	[M300]
22	LD	[M300]			(T450)	[K 1.0]
25	LD	[T450]			R	[Y444]
					R	[M300]
					S	[M301]
					S	[M307]
30	LD	[M300]	AND	[X514]	R	[M303]
					R	[Y444]
					R	[Y440]
					R	[M307]
					R	[M301]
					S	[M302]
					S	[Y433]
39	LD	[M301]			(T451)	[K 1.0]
42	LD	[T451]			R	[Y442]
					R	[M301]
					S	[M302]
46	LD	[M302]			(T452)	[K 1.0]
49	LD	[T542]			R	[Y440]
					R	[M302]
					S	[M303]
					R	[M307]
54	LD	[M303]			(T453)	[K 1.0]
57	LD	[T453]			S	[Y433]
					R	[M303]
60	LD	[X412]	AND	[X405]	R	[Y442]
					R	[M303]
63	LDI	[X405]	ANI	[X406]	R	[Y433]
					S	[Y532]

Figure 4.2 Part of the PLC mnemonic code showing the routine for the loading station

With reference to Figure 4.1, a workpiece carrier can enter the loading station if it is empty, this condition is represented by the instruction ANI 404 at step 15.

When the workpiece carrier gets to the loading position, access to the next workpiece carrier is denied in step 18 (R [Y531]) and the sequential actions of the loading mechanism are instigated, the suction cup is positioned over the bodyshell at the bottom of the chute step 19 (S [444]) and then the vacuum is activated (S [Y440]). The next action is to return cylinder A¹, to its rest position at step 26 (R [Y444]) which lifts the bodyshell from the chute. The delay mentioned earlier is placed between these last two actions to ensure that the cylinder returns to the rest position only after it has reached the bodyshell and the vacuum operated. The only other way to do this would be to fit limit switches to the cylinders and wait for them to be activated.

Steps 30 - 38 are the recovery actions if the bodyshell is not there or is dropped during the transfer from chute to workpiece carrier.

Step 43 (R [Y442]) activates cylinder B moving the bodyshell over the workpiece carrier, a delay was found to be necessary here as operating cylinder B at the same time as returning cylinder A to its rest position often resulted in the bodyshell being dropped. The vacuum is deactivated at step 50 and after a further delay the gate of the loading station is operated (line 19) allowing the workpiece carrier to move out of the loading station and cylinder B is returned to its rest position at step 62 (R [Y442]). Finally the gate is closed at step 65 (R [Y433]).

4.2.2 Identification station.

This section presents the software used by the vision system and the PUMA robot-vision system interface. The software is split into two parts: off-line and on-line called **OWLDB**² and **OWL** respectively. The off-line part is used in the generation of the pattern recognition and the vision-PUMA calibration databases which are then used by the on-line software for identifying

¹ Cylinders A and B of the loading mechanism in Figure 3.2.

² OWLDB is short for OWLDataBase. The three main programmes of the proof-of-concept cell are OWL, EAGLE and PUFFIN, which control the vision system, PUMA and RTX robots respectively.

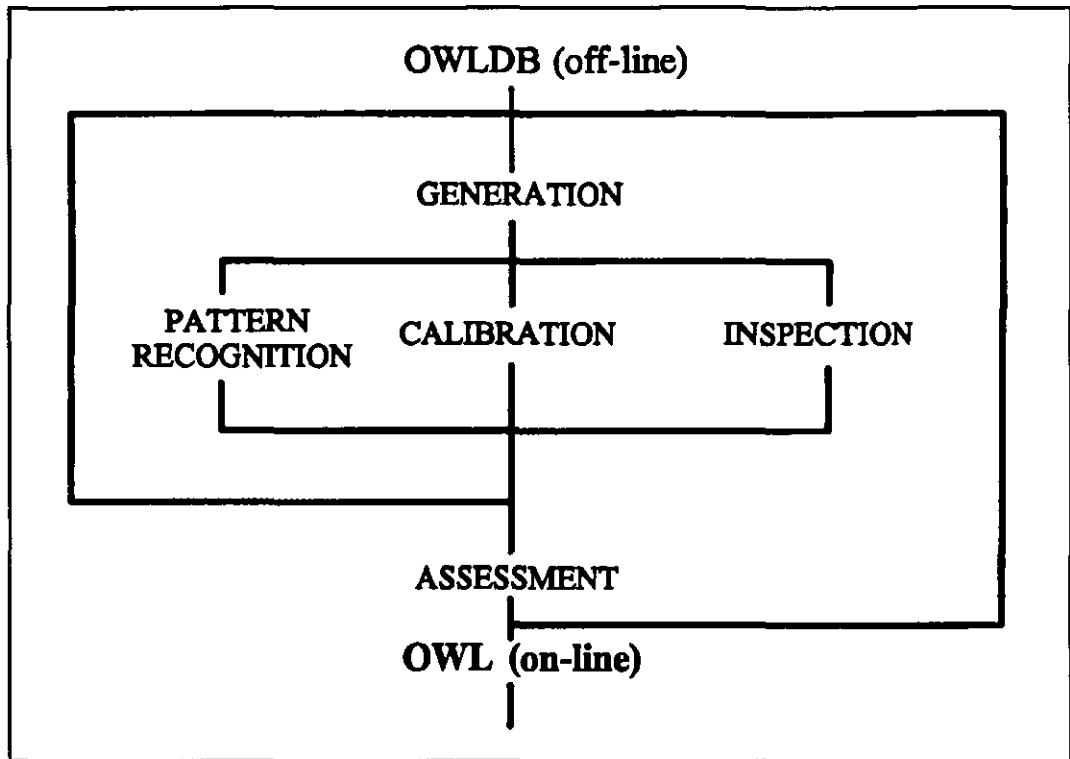

Figure 4.3: Structure of the off-line programme of the identification station

the bodyshells and managing the robot-vision interface.

To make the software user friendly the generation of the inspection database was also included in OWLBD. The operator can therefore generate all the databases needed through a single programme. The structure of OWLDB is represented in Figure 4.3. The generation of the pattern recognition and calibration databases will be described in section 4.3 and the inspection database in Section 4.4.

4.2.3 Decoration station.

The software of this station consists of three sub-routines in TUCANO which take control of the Tampo printing machine. They are:

- **SWEEP.TAMPO** - continuously keeps the doctor blade/spatula carrier sweeping ink over the cliché when the PUMA robot is not at the Tampo printing machine.
- **STOP.TAMPO** - stops the Tampo printing machine so allowing the PUMA robot to manoeuvre the matrix in front of the printing machine.

- **PRINT.TAMPO** - executes the preset print cycle of the printing machine.

These routines are very simple, consisting mainly of switching the appropriate output lines on the PUMA I/O board. Figure 4.4 lists the sub-routine **TUCANO** from where these routines are called. The code of the sub-routine **PRINT.TAMPO** is given in Figure 4.5.

```

1  SPEED 80 ALWAYS           ; set speed to medium
2  MOVE #bonnet.out          ; move robot in front of printing machine
3  WAIT TIMER (-1) == 0      ; wait for robot to get to location
4  CALL stop.tampo
5  WAIT SIG(2001)            ; printing machine stopped
6  DISABLE CP                ; stop firmware 'rounding' corners
7  MOVES blup                ; move above first print location
8  MOVES b1                  ; move to first print location
9  WAIT TIMER (-1) == 0
10 CALL print.tampo          ; activate printing machine
11 WAIT SIG(2001)            ; finished printing
12 MOVES b2up                ; move up from final print position
13 CALL sweep.tampo          ; restart 'idle' cycle
14 flag = TRUE                ; needed to keep sweep.tampo running
15 DEPARTS CP                 ; move away from printing machine
16 ENABLE CP                  ; go back to normal mode
17 MOVE rupb                  ; move round from printing machine
18 SPEED 100 ALWAYS          ; set speed to fast
19 RETURN
.END

```

Figure 4.4: The VAL II code of TUCANO.

```

1  ; *** PROGRAMME PRINT.TAMPO
2  ; *** activates the print cycle (manually chosen)
3  end = 0                    ; set up counter
4  SIGNAL (-2001)             ; switch off internal flag
5  SIGNAL (-9)                ; switch to print sequence
6  SIGNAL (-10)
7  DELAY 0.5
8  SIGNAL (8)                  ; 'press' start switch
9  DELAY 0.5
10 SIGNAL (-8)                 ; 'release' start switch
11 DO                          ; print the first decoration
12   IF SIG(1001) THEN
13     end = end + 1
14     DELAY 1.0
15   END
16 UNTIL end == 2
17 WAIT SIG(1005)              ; pad at top
18 CALL print.bonnet          ; print the rest of the decoration
19 WAIT SIG(1003)              ; arm at back
20 SIGNAL (12)                 ; 'operate' the foot switch
21 DELAY 0.8
22 SIGNAL (-12)                ; 'release' the foot switch
23 SIGNAL (2001)               ; finished
24 RETURN

```

Figure 4.5: The VAL II code of PRINT.TAMPO

4.2.4 Inspection station.

The vision system inspects the decorated bodyshells for:

- position and completeness of the decoration
- smudging
- shades of colours.³

The inspection is based upon a comparison of the decorated bodyshell with that of a reference model. All the relevant features of the reference model are derived off-line and stored in a database. The on-line inspection programme reads in this database and compares the features of the decorated model with that in the database.

In a way this process is similar to that of pattern recognition although it is simpler in that the correlation of the features is not relevant, i.e. if the position of the decoration is incorrect then this gives the inspection software a basis for a decision, it is clearly not necessary to investigate further.

The programmes were derived with a feature which makes the decoration inspection very quick and reliable: windows allocation {Trabasso et al, 1991f}.

The principle of windows allocation is very simple: the off-line programme allows the user to define windows around the features to be inspected, and the origin and size of the various windows are recorded in the inspection database. The on-line programme rebuilds these windows and then scans the first one. If the relevant decoration is found and its attributes are within the preset tolerances the next window is scanned and so on, otherwise the bodyshell is rejected at the first window.

This windows allocation approach allows for a tremendous reduction in the number of pixels scanned. In the bonnet inspection of the Texaco Sierra, for example, the number of pixels scanned is reduced by 97% from 64,536⁴ to 2,000 pixels.

³ This is not fully implemented as it requires a colour vision system. The inspection of shades of colour with a monochrome system is explained later.

⁴ Half resolution of the MAGISCAN vision system.

4.2.5 Unloading station.

PUFFIN is the programme which controls the RTX robot, it is written in **Forth** and structured in elementary units called **words**. A word in Forth corresponds to a procedure in Pascal or a sub-routine in VAL II. With reference to Figure 4.6, it is easy to follow the actions performed by the RTX robot just by looking at the **PUFFIN** source code⁵.

The word **REC** receives action data from the PUMA robot via the RS-232 link and stores them in the variable **DECISION**. Based upon the current value of this variable the RTX robot carries out one of the following actions:

- **DECISION = 84:** (ASCII⁶ code T for tray) the RTX robot moves the top transport tray from the 'empty' stack to next position on the 'load' stack where the decorated bodyshells which pass inspection will be palletised
- **DECISION = 66:** (B for bin number) after identifying a bodyshell at the identification station the vision system sends the RTX controller the corresponding bin number. The word **STORE_DATA** stores this variable in the array **MODELS**.
- **DECISION = 80:** (P for palletise) the bodyshell has passed inspection and the RTX palletises the bodyshell. The word **PALLETISE** is composed of the longest chain of words within **PUFFIN** as it involves interaction with the PUMA robot and the PLC as well the updating of a number of arrays and variables.
- **DECISION = 102:** (f for fail) this tells the RTX controller to place the next bodyshell in the reject/rework box.
- **DECISION = 83:** (S for stop) This is the stopping code. The PUMA robot controller sends the same signal to the vision system and the PLC as well. After receiving this code the RTX robot returns to its **HOME** position.

⁵ Note that some structures common to most programming languages are written in different order in Forth. The corresponding structure of line 5 in Pascal is: IF DECISION = 84 THEN

⁶ American Standard Code for Information Interchange.

```

0  : PUFFIN { MAIN PROGRAMME}
1  CLEAR_SCREEN 0 COUNT ! 0 DECISION ! 0 MODELS !
2  ATTACH_GRIPPER
3  BEGIN
4      REC DECISION !
5          DECISION @ 84 - IF FIRST_TRAY
6          ELSE DECISION @ 66 - IF STORE_TRAY
7          ELSE DECISION @ 80 - IF PALLETISE
8          ELSE DECISION @ 102 = IF REJECT
9          THEN THEN THEN THEN
10 DECISION @ 83 = UNTIL
11 CR ." Finishing " CR HOME CR ." Finished" CR ;
12
13
14
15

```

Figure 4.6: The PUFFIN source code.

The main action of the RTX robot is the palletisation of the correctly decorated bodysells. An overview of the corresponding code follows. The initial action of the word **PALLETISE** is to read the first value of the array **MODELS**. This will decide which bodysell will be palletised and onto which transport tray. The array **MODELS** is updated and the code moves down to the next word. Based on the value of a counter this word decides on which of the six possible locations on the tray the bodysell will be placed.

Even though there are 30 palletising positions only 6 needed to be taught to the RTX as the coordinates for each tray differ only in height. When the value of the counter reaches six the RTX robot places a new tray on the 'load' stack, taking into account the number of trays already on the stack.

Figure 4.7 gives an example of the code needed to palletise the Ford Sierra at the first position of a transport tray. **ABOVE_PUMA** and **FROM_PUMA** are taught locations. Note the way the RTX controls the vacuum ON and OFF in lines in lines 1 and 7. The command **BIT** is used to control the output port linked to the PLC which switches the solenoid valves linked to the suction cups ON and OFF accordingly. This is a somewhat tortuous path but it avoided building another interface between the RTX controller and the valves.

```

0 : SIERRA[1] {model location}
1 ABOVE_PUMA FROM-PUMA SUCK_MODEL
2 ROBOT_TRAFFIC
3 GET_HEIGHT_UP_MODEL
4 -1544 312 WRITE_Z -756 -1636 -489 0 GOTO>POS
5 GET_HEIGHT_UP_MODEL
6 -1544 312 WRITE_Z -756 -1636 -489 0 GOTO>POS
7 BLOW_MODEL
8 GET_HEIGHT-UP_MODEL
9 -1544 312 WRITE_Z -756 -1636 -489 0 GOTO>POS
10 100 ZED !SPEED ABOVE_PUMA 160 ZED !SPEED ;

```

Words used in the above code

```

: SUCK_MODEL 1 0 0 !BIT ;

```

```

0 : ROBOT_TRAFFIC
1 71 760 PC! {model grasped move on}
2 BEGIN 760 PC@ 77 = UNTIL {from Puma - path clear -> move on}
3 42 760 PC! {to Puma - over} ;

```

```

: GET_HEIGHT_MODEL MODEL_HEIGHT @ ZED !NEW_POS ;

```

```

: WRITE_ZED ZED @NEW_POS ;

```

```

: BLOW_MODEL 0 0 0 !BIT ;

```

Figure 4.7: An example of the palletising code.

The word **ROBOT_TRAFFIC** is used for synchronising the movements of the robots. **760 PC!** sends data over the RS-232 link to the PUMA controller, it is used in this instance to signal that the bodyshell has been grasped and that the PUMA robot can now be moved away from the unloading location. When the PUMA robot receives the signal in line 2 it moves away and sends a signal to the RTX to move (line 3). Line 4 is the handshake code for the PUMA-RTX serial link.

4.3 THE JOYCE-LOEBL MAGISCAN VISION SYSTEM.

To understand the effort that has to be put into writing a vision system programme a comparison between this task and the manufacture of an printed circuit board would seem appropriate.

After defining the functional requirement of the circuit board the designer then has to decide how to connect components in order to achieve the desired result. The majority of the electronic components needed are available off the shelf, such as diodes, transistors, resistors and integrated circuits. Sometimes the designer has to resort to designing specific components but this is only in the case of a very specialised circuit board.

Keeping this comparison, the MAGISCAN vision system can be thought of as a shelf from which the various 'components' for 'assembly' of a programme can be taken. It is up to the programmer to assemble these components in the necessary order to achieve the desired result.

As various electronic components can be found in a single chip so can various routines in MAGISCAN be found in units. For instance, the unit MXRT contains the routines to execute operations with images such as addition, subtraction, edge enhancement and so on; the unit MXTYPES contains all types⁷ used in MAGISCAN, starting with a simple constant such as Π up to complex records composed of a number of fields. All the units can be compiled separately from the users programme. For a complete description of the MAGISCAN units, refer to Joyce-Loebl {1987}.

For accessing the routines of these units, the programmer has to declare them in the header of his programme and subsequently link the object code of the programme to the object code of the units. This is done using the DOS linker.

A typical user programme that makes use of the MAGISCAN units is shown in Figure 4.8. Normally only the executable code is supplied with a MAGISCAN vision system, but Joyce-Loebl supplied an 'open version' to the Department of Mechanical Engineering to enable work to proceed with this project. This allows for some useful modifications to the original procedures, for instance the inclusion of new parameters to be output from a particular procedure. It also allows for the inclusion of totally new procedures into the units.

The following were added to the original units:

- **MXPUMA:** all the procedures for communication with the PUMA robot including

⁷ Pascal structure.

the RS-232 machine code routines for the vision-robot serial link.

- **PUMACAL:** the procedures used in the calibration of the interface between the vision system and the PUMA robot.
- **INSPECT:** the procedures used in the inspection of the bodyshells.

```
{ $include: 'mxtypei.txt' }
{ $include: 'mxrti.txt' }
{ $include: 'mxsysi.txt' }

{ $include: 'mxmeasi.txt' }

program <name> (input,output);

uses;
    mxtypes, mxrt, mxsys, ..... , mxmeas;

begin
    <body of programme>
end.
```

Figure 4.8: Typical structure of a Pascal programme using MAGISCAN units.

4.3.1 Training process.

The first role played by the vision system is to recognise a specific bodyshell. It can only do this if the particular bodyshell is in the database of models available to the vision system. The process of building up an off-line database for pattern recognition is called the training process {Trabasso et al, 1991e}. A brief description of this process follows.

The bodyshell is presented to the vision system at a reference position chosen by the operator. The position is recorded as the template position and later used as the reference point for calculating the orientation angle of the bodyshell. The sampling process then takes place whereby the vision system takes fourteen measurements of the bodyshell, nine of them related to the internal features and the remainder based upon the external features, {Joyce-Loebl, 1985}. Some of the measurements have physical meaning such as perimeter, area, length, width. Some, however, are made up in order to improve the results of the training process. For example the quantity perimeter x distance⁸ is frequently used.

After the first set of measurements has been processed the bodyshell is moved to a new position, the same measurements are taken and the database is updated. This sampling process is repeated until a significant database for the model has been constructed. The number of samples depends on the complexity of the object being viewed. Based on experimental results, the minimum number of samples for the actual bodyshell being used is twenty.

4.3.2 Flowchart and data file output.

Figure 4.9 shows a typical data file output which contains the statistical database of an object to be used with the classification routines.

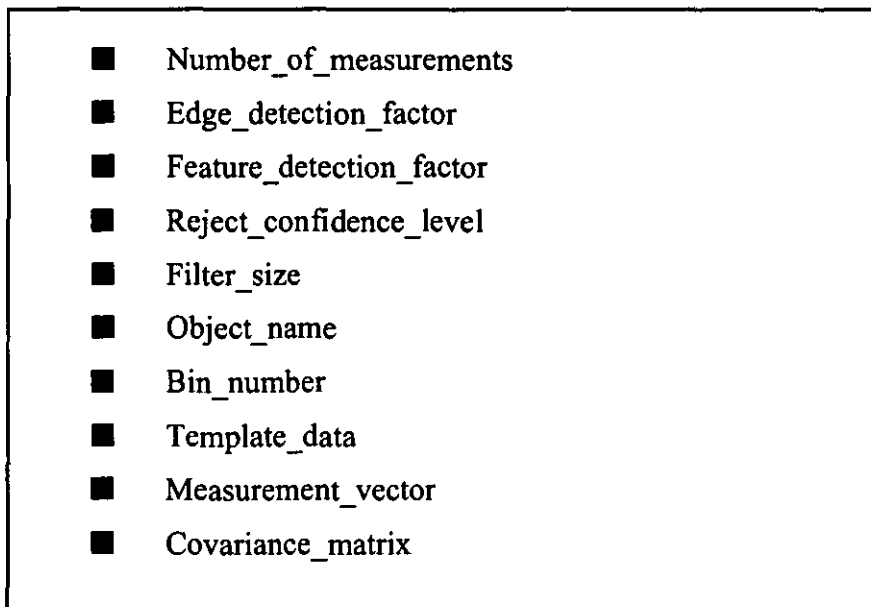

Figure 4.9: Typical data file structure.

⁸ Distance is the distance between the actual centre of area to the centre of area of the object at the template position.

A library contains up to twenty such data files, i.e. it is possible to place twenty different objects in a single library. The MAGISCAN vision system allows for up to ten different libraries.

There is a practical criterion for placing different objects in a library. That is to select objects with similar levels of contrast relative to the background; this prevents light and dark coloured objects being placed in the same library. The contrast level is reflected in the edge and feature detection factors. Figure 4.10 shows the flowchart of the training process.

4.3.3 Off-line assessment.

Before using the data generated by the training process in an on-line programme the operator has the option of assessing the results of the training off-line. All that is required is to place the object of interest in the field of view of the vision system either in the position it will be presented to the vision system or in a totally random position. The programme checks to see if the object belongs to the library selected and outputs the following information:

- Object name and bin number
- Orientation angle
- Confidence level.

This process should be repeated a number of times. The indication of a successful training process is that the confidence level stays at the highest possible value 9 for all positions and that the orientation angle does not exceed $\pm 2^\circ$ when the bodyshell is not moved.

4.3.4 Vision system PUMA robot calibration.

The measurements taken by the vision system are expressed in pixels and these then have to be converted into metric units for the robot controller to be able issue movement instructions to the robot arm. MAGISCAN provides a straightforward method of converting pixels into millimetres using light pen calibration. All that has to be done is to place an object of known length, a ruler of example, into the field of view and using the light attached to the system draw a line

along the object. The vision system then calculates the number of pixels in the line and outputs a calibration factor expressed in pixels/millimetre.

If a tube camera is used then this calibration needs to be executed only once with the object positioned either horizontally or vertically relative to the axis of the camera. This is because the pixels in a tube camera are square shaped. However, if a CCD camera is used then the calibration procedure must be carried out in both the horizontal and vertical directions as the pixels produced from a CCD camera are rectangular.

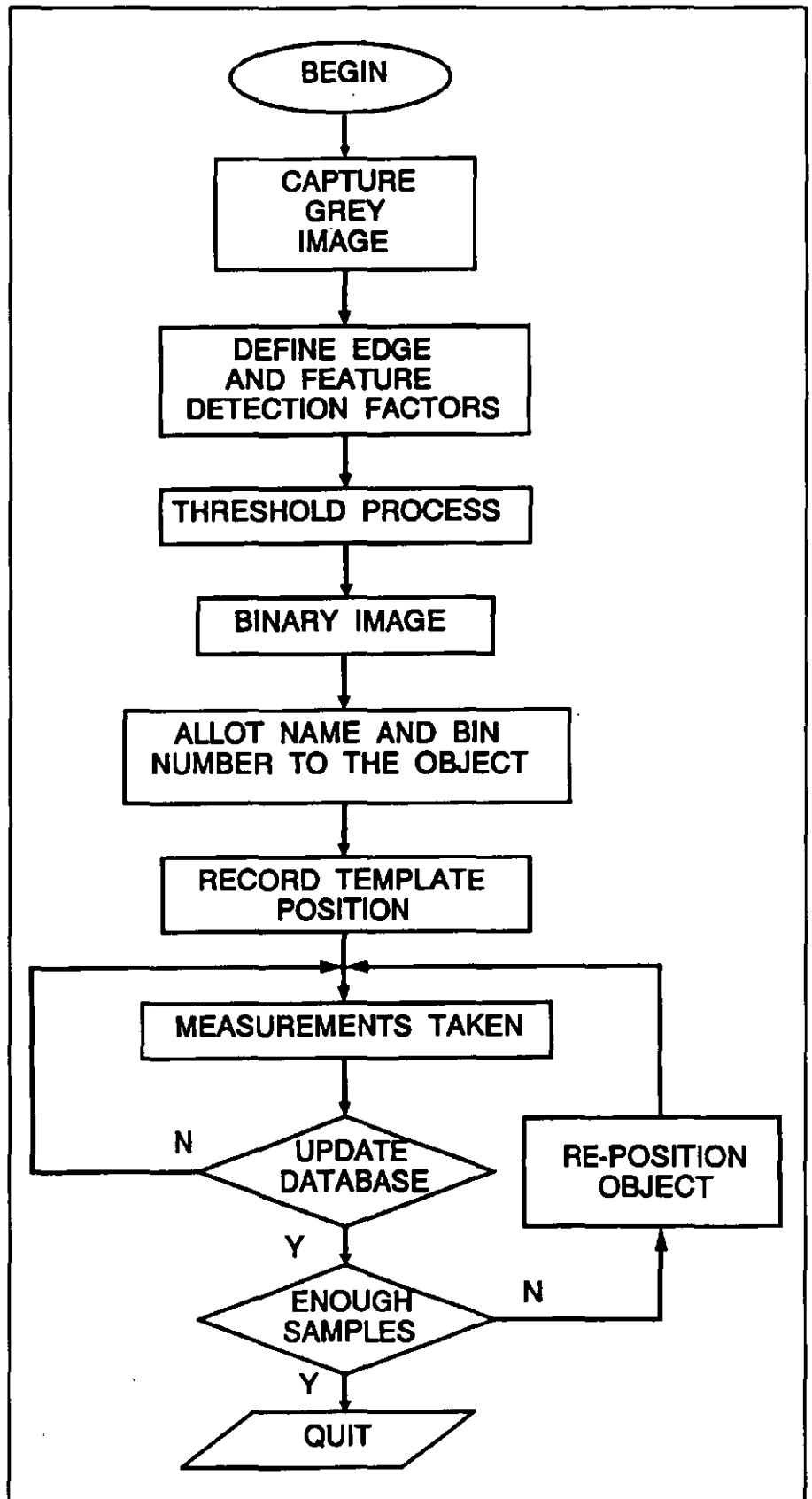

Figure 4.10: Flowchart of the training process.

Whilst this system works very well off-line it does not allow for on-line calibration. To give

the system the capability of on-line calibration the workpiece carriers had calibration marks built into them. These are small black circles on the top face of the perspex machined 250 millimetres apart and can easily be detected by the vision system. Because the size of the calibration marks are small and known the vision system can be instructed to ignore them when analysing the contents of the workpiece carrier, but they can be used for on-line calibration when required.

A full description of the calibration procedure is given in Trabasso and Zielinski {1990}.

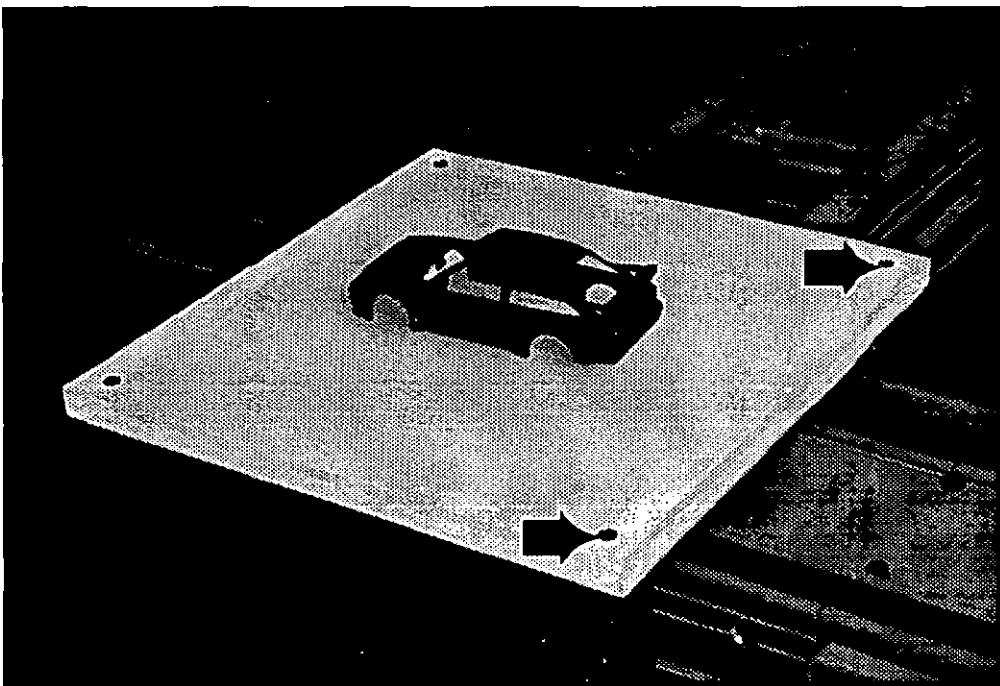

Figure 4.11: The calibration marks on the workpiece carriers.

4.4 GENERATION OF THE INSPECTION DATABASE.

This will be described taking the decoration of the bonnet of a Texaco Sierra as an example. Obviously all the procedures described here are just as valid for other parts of the model as they are for a completely different model.

To generate the inspection database it is first necessary to position the reference model in the

inspection station using the PUMA robot. A typical view of the image to be analysed by the inspection station is shown in Figure 4.12. Note the reference marks in this figure; they are the two small white circles on the right edge of the image just inside the windscreen area. These marks are used for two purposes a) to check if the matrix has been positioned correctly and b) as reference positions when checking the locations of the various parts of the decoration on the model.

In an image with different contrast levels, as is the case in this example, the operator can split the inspection operation into two or three stages if necessary. In this example the inspection is split into light and dark features which correspond to the white and red printing. After obtaining a binary image through the thresholding process the operator selects the relevant features of the image.

This step is necessary because sometimes a reflection from the lighting system might be present in the binary image and it has to be disregarded by the inspection process. Figure 4.13 shows the result of the thresholding process applied to the grey image of Figure 4.12.



Figure 4.12: Typical image at the inspection station.



Figure 4.13: Binary image of the bonnet highlighting light features.

The operator is then prompted with the screen shown in Figure 4.14. In this particular example he should enter the numbers 1,5,2 and 4 respectively to select the four features of interest. The same operation is repeated for the dark features if required. That is because the operator is given the option of a complete or partial inspection, for instance it is possible to inspect only the white star of the Texaco logo and ignore the red circle underneath or vice-versa.

After the decoration selection, the programme calculates the features of the decorations. The first is the perimeter, this is used to check if the logo is smudged or only partially printed.

For recording the position of the decoration the programme calculates the distance square⁹ between the centre of the boundary of the decoration and the centre of boundary of one of the reference marks. The orientation of the decoration is calculated as the angle between its longest diameter relative to the horizontal plane of the vision system.

The information about the shades of colour of the decoration can also be obtained despite the use of a monochrome vision system. This is achieved through window allocation and the grey scale: the operator defines a small window¹⁰ which lies on a certain colour. The inspection

⁹ This is to avoid the extra calculation of the root square.

¹⁰ Which contains approximately 50 pixels.

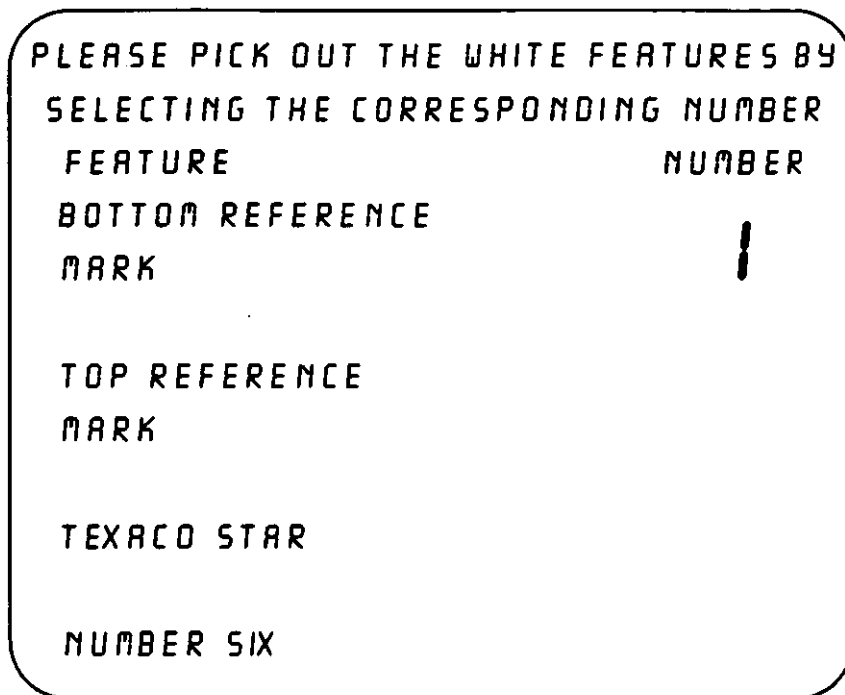

Figure 4.14: Computer screen of bonnet white features selection.

routine then calculates the mean grey level of the pixels inside the window according to equation 4.1.

$$GL = \frac{\sum_{i=1}^{np} g_i}{np} \quad (4.1)$$

The grey scale of the MAGISCAN vision system runs from 0 (darkest) to 63 (lightest) and can be used for a great number of different shades of colours. It has been successfully used with the bodyshell being tested for the purpose of inspection. Clearly this method will fail if it is used for **identifying** colours. The **gl** values of black and dark blue for instance are so close as to make them meaningless for identification, but for **comparison** purposes the technique holds.

After calculating the perimeter, position, orientation and mean grey level of a decoration, the programme prompts the operator with windows definition and positioning. The system initially positions the bottom left corner of the window at the centre of boundary of the decoration. The operator defines the size of the window and re-positions its origin in order to enclose the decoration using the light pen. When all of the windows have been defined successfully the inspection database is generated.

A typical structure of an inspection database is presented in Figure 4.15.

Note that the threshold values associated with the reference marks and the decorations are also recorded. This makes it absolutely essential to have the lighting conditions of the on-line inspection set to the same level as that used to generate the database.

Inspection_code	}	Total or partial inspection
Threshold_min, Threshold_max		
Ref.mark_x, Ref.mark_y	}	Top reference mark
Window_x, Window_y	}	
Window_Δx, Window_Δy	}	
Ref.mark_x, Ref.mark_y	}	Bottom reference mark
Window_x, Window_y	}	
Window_Δx, Window_Δy	}	
Threshold_min, Threshold_max	}	First decoration
Window_x, Window_y	}	
Window_Δx, Window_Δy	}	
Perimeter	}	
Distance_to_reference	}	
Orientation_angle	}	
Mean_grey_level	}	
Threshold_min, Threshold_max	}	Second decoration
Window_x, Window_y	}	
Window_Δx, Window_Δy	}	
Perimeter	}	
.....		

Figure 4.15: Typical data structure of the inspection database.

4.5 THE ON-LINE PROGRAMME - OWL.

Section 4.4 described the action of the off-line programme OWLDB. The data generated by this programme, namely the pattern recognition and calibration databases, is used by the on-line programme in order to:

- identify the bodyshell on the workpiece carrier
- drive the PUMA robot to pick up the bodyshell from the workpiece carrier.

To identify a bodyshell the vision system again takes a set of measurements and compares it with the database, and based upon the distance from the set in the database, will either accept or reject it. There is a tolerance that has to be set in the classification process in order for the bodyshell to be accepted as a member of the database. This tolerance level is defined as the confidence level of the process and is set by the user. The minimum and maximum levels in the MAGISCAN system are 0 and 9 respectively. After successfully identifying a bodyshell the vision system sends the following information to the PUMA robot:

- Bin number, which uniquely identifies each model in the library
- The x and y co-ordinates of the centre of boundary of the bodyshell, already transformed into robot world co-ordinates by the factors in the calibration database
- Orientation angle, which is measured from the reference model in the database.

With this information the PUMA robot programme EAGLE modifies the location of the centre of boundary of the bodyshell as follows:

$$\text{SET<bodyshell>} = \text{TRANS (x,y,z,o,a,t)}$$

where x, y and o are sent by the vision system, and z, a and t are set by the operator: z is the height of the bodyshell measured from the workpiece carrier, a and t are the angles which determine the complementary orientation of the robot gripper. Figure 4.16 shows a simplified flowchart of the on-line programmes.

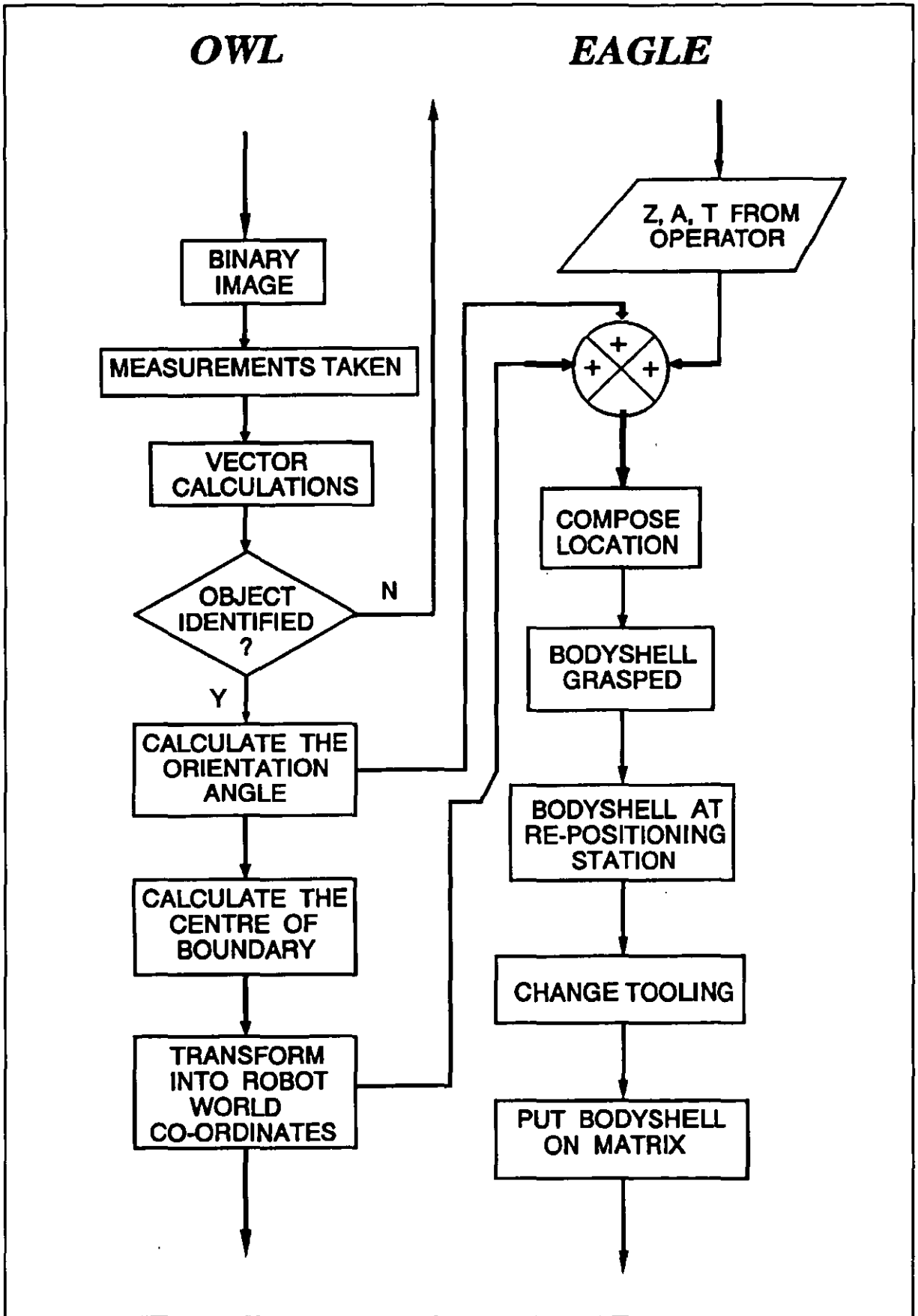

Figure 4.16: Flowchart of the interaction between OWL and EAGLE.

CHAPTER 5:
**THE ELECTRONIC AND ELECTRICAL
DESIGN OF THE CELL.**

5.1 SUMMARY

This chapter presents the electrical and electronic design of the five component parts of the proof-of-concept-cell. It also covers the sensors and associated electronics employed.

Compared to the mechanical and computer design stages the electronics design was much simpler in that most of the equipment used was readily available off-the-shelf, such as the PLC, camera/computer interface and most importantly the robot controllers.

When mentioning the equipment used the author will limit the information to that which is relevant to the proof-of-concept cell. Further details can readily be obtained in the suggested references.

An important part of the control of the cell is the communication between the various components using an RS-232C serial link, and this will be described.

Because the PLC is also used for control at the identification station and unloading stations as well as the conveyor system, it will be reviewed in a general manner. This will make it easier to describe its particular use in the various parts of the proof-of-concept cell later on.

5.2 THE RS-232C SERIAL LINK.

In serial data transmission one data bit is transmitted after another. In order to transmit a byte of data it is therefore necessary to convert incoming parallel data into a serial bit stream which can then be transmitted along a line.

Serial data transmission can be synchronous (clocked) or asynchronous (non-clocked). The latter method is by far the most popular method. The rate at which data is transmitted is given by the number of bits transmitted per unit time. The commonly adopted unit is the 'baud', with one baud roughly equivalent to 1 bit per second.

It should, however, be noted that there is a subtle difference between the bit rate from the computer and the baud rate in the transmission line. This is simply because there is some

overhead in terms of the extra synchronising bits required in order to recover asynchronously transmitted data.

In the case of a typical RS-232C link, a total of eleven bits are required to transmit only seven bits of data. A line baud rate of 600 baud, therefore, represents a data transfer rate of around 382 bits per second.

The interface is defined by the Electronic Industries Association (EIA) and relates to the connection of data terminal equipment (DTE) and data communication equipment (DCE). For many purposes the DTE and DCE are the computer and peripheral respectively although the distinction is not always so clear as, for example, in the case of two computers being linked via RS-232C ports. In general, the RS-232C system may be used where the DTE and DCE are physically separated by up to 20 meters or so at a baud rate of 19.2Kbaud - although at the low baud rates distances can be up to 400 meters. For greater distances telephone lines are usually more appropriate.

The EIA specification allows for the following signals:

- serial data comprising
 - (i) a primary channel providing full duplex data transfer¹
 - (ii) a secondary channel also capable of full duplex operation
- handshake control signals
- timing signals.

RS-232C is versatile and highly adaptable; unfortunately such flexibility carries a penalty - the wide variation in interpretation, which can result in some bewildering anomalies in the physical connection and control of practical RS-232C systems.

The most commonly used signal lines are shown in table 5.1. For a full description of the RS-

¹ Simultaneous data transmission and reception.

Table 5.1: The most popular pins implemented in an RS-232C serial link.

PIN	NAME	ABBREVIATION
1	Frame ground	FG
2	Transmit data	TX
3	Receive data	RX
4	Request to send	RTS
5	Clear to send	CTS
6	Data set ready	DSR
7	Signal ground	SG
8	Data carrier detect	DCD
20	Data terminal ready	DTR

232C interface refer to Seyer {1984}. Because only 8 of the lines are normally used many computer manufacturers are now using 9 way 'D' connectors to save space on the back panels. This wiring is, however, not standard and can vary from manufacturer to manufacturer.

The minimum possible configuration of an RS-232C link is three lines as shown in table 5.2. The PUMA controller is only provided with this minimum configuration so that it was necessary to implement the handshake routines between the component parts by software.

Table 5.2: The minimum configuration of an RS-232C serial link.

PIN	NAME	ABBREVIATION
2	Transmit data	TX
3	Receive data	RX
7	Signal ground	SG

To establish a reliable link between computers and peripherals using RS-232C certain criteria have to be met. These are:

- Baud rate of the transmitting and receiving units must be the same
- A buffer must be available in which the data can be temporarily stored during transmission
- Software management of the transmission line must be established.

The software to support such a link varies from computer to computer; for instance, in VAL II there is a special set of instructions called the Z-instruction set, in FORTH the instructions PC@ and PC! are used and in Microsoft Pascal the routines have to be written in assembler and then used as a procedure.

5.3 PROGRAMMABLE LOGIC CONTROLLER.

Up to the late 1960's electromechanical relay panels were the standard technique for accomplishing sequential control in industrial applications: after that date Programmable Logic Controllers were introduced as a replacement for them. A PLC, like a relay panel, is made up of multiple relays, timers and counters. However, the internal wiring in a PLC is executed by programming, making PLC's smaller, more reliable and flexible.

According to the manufacturers of PLC's they are defined as digitally operating devices with a programmable memory and are capable of generating output signals according to the logic operations performed on the input signals. In a typical industrial system the inputs to a PLC are provided by limit, proximity or photo-electric switches and outputs are used to drive motors, solenoid valves, lamps, electromagnetic clutches and so on.

The functions that a typical PLC can accomplish are:

- **Control relay functions:** generation of an output signal based on the logic rules applied to the inputs
- **Timing functions:** generation of an output signal for a specified length of time, for example

- **Counting functions:** generating an output signal when the value of a counter reaches a preset level
- **Arithmetic functions:** execution of the basic arithmetic operations of addition, subtraction, multiplication and division
- **Analogue control:** emulation of analogue functions such as proportional, integral and derivative control.

A Mitsubishi Melsec F1-40MR PLC was used to control the proof-of-concept cell; this unit has 24 inputs and 16 outputs, but has since been expanded to 48 inputs and 32 outputs with an extension unit to cope with the extra items to be controlled.

5.3.1 Control of the workpiece carriers around the conveyor system.

The Bosch modular conveyor system uses electrically operated pneumatic gates and inductive switches to control the flow of workpiece carriers around a conveyor network. Figure 5.1 gives an example of the typical wiring connections required at a 'stop position'.

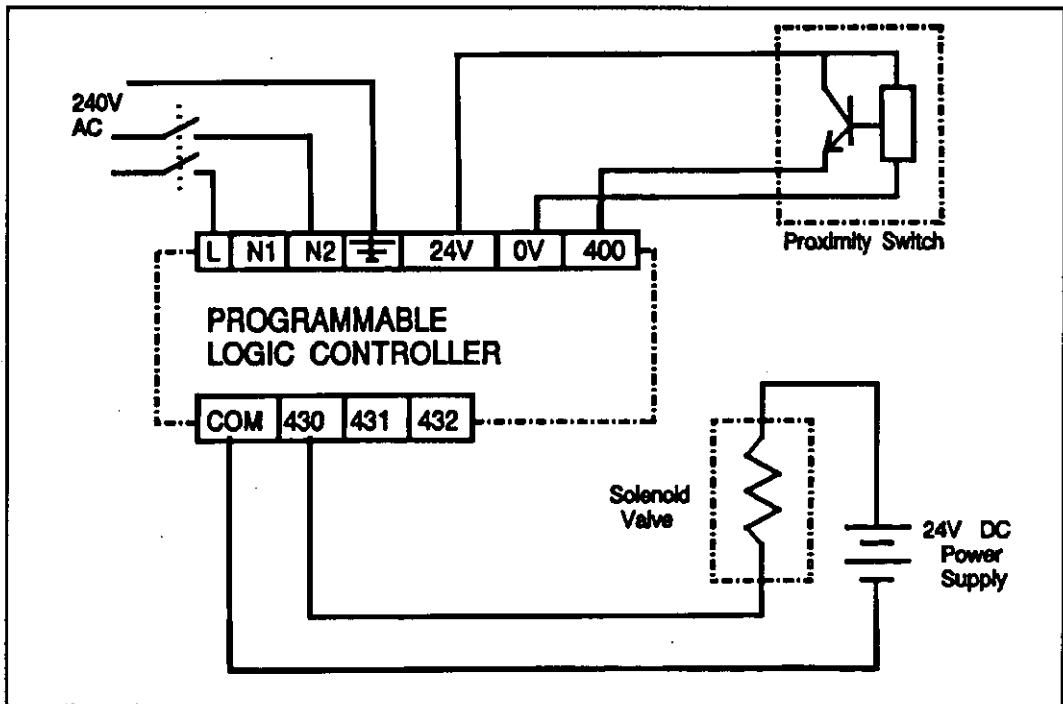

Figure 5.1: Typical wiring connections between the PLC and a proximity switch and stop gate.

The programme instruction between the two components could simply be:

LOAD 400 ----- OUTPUT 430

Which would be represented in the ladder diagram as:

X 400 [] (Y 430)

This instruction means that the PLC will scan the status of input 400 and when it goes high (positive) then the output transistor 430 will be pulsed on. If the output is required to be turned on for longer periods then it is necessary to resort to using internal relays to achieve this.

In addition to connecting the stop gates and the proximity switches to the PLC, the lift units at the ends of the traverse sections of the conveyor system also have to be controlled to enable the workpiece carriers to flow smoothly around the conveyor system.

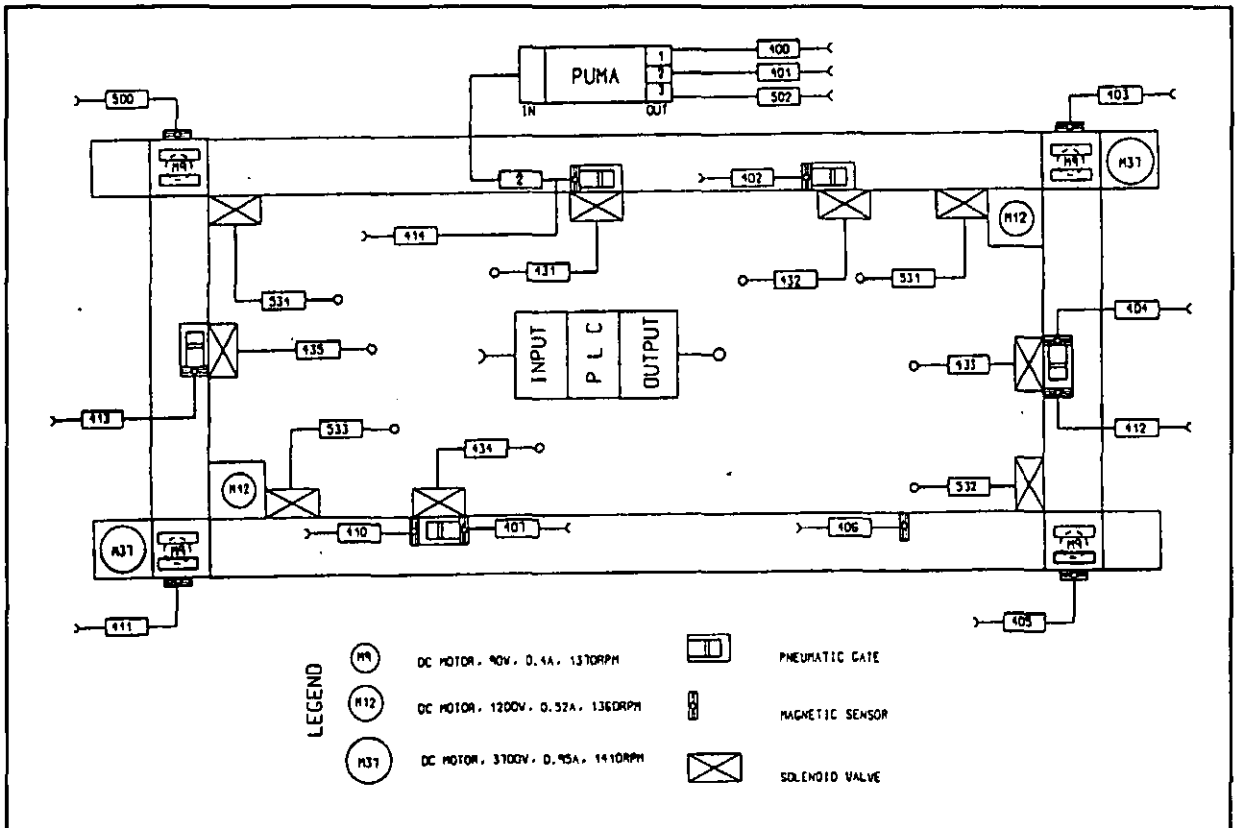

Figure 5.2 Schematic of the PLC connections in the proof-of-concept cell.

Figure 5.2 shows the PLC connections to the solenoid valves and the proximity switches neces-

sary for control of the workpiece carriers around the conveyor system as well as the connections to the PUMA and RTX robots. Solenoid valve 433 and proximity switch 412 control the workpiece carriers at the loading station, and solenoid 431 and proximity switch 414 control them at the identification station. The other solenoids and proximity switches are necessary for holding the workpiece carriers while they wait to enter the various stations.

5.4 ELECTRONIC SYNTHESIS OF THE FIVE STATIONS.

5.4.1 Loading station.

The control requirements of this station are:

- stop and release the pallets at the loading position
- execute the sequential movements of the loading station
- monitor the presence of the bodyshell in the loading station.

It was decided to use the same PLC that was controlling the conveyor system for the first two requirements and an opto-switch for the third.

5.4.1.1 Sequential control of the loading mechanism.

The components necessary for controlling the sequential action of the loading station are shown in Figure 5.3. For the sake of clarity the components and wiring are shown schematically. The proximity switches are designated **PS** and the solenoid valves **SV²** with the following associated functions:

- **PS1** monitors the presence of the workpiece carriers at the loading station and triggers the sequential action of the loading mechanism.

² This terminology will be used throughout the rest of the chapter.

- PS2 resets the loading station ready for the next workpiece carrier.
- SV1 controls the action of cylinder A (refer to Figure 3.2).
- SV2 controls the action of cylinder B.
- SV3 controls the air supply to the suction cup.
- SV4 controls the stop gate at the loading station.

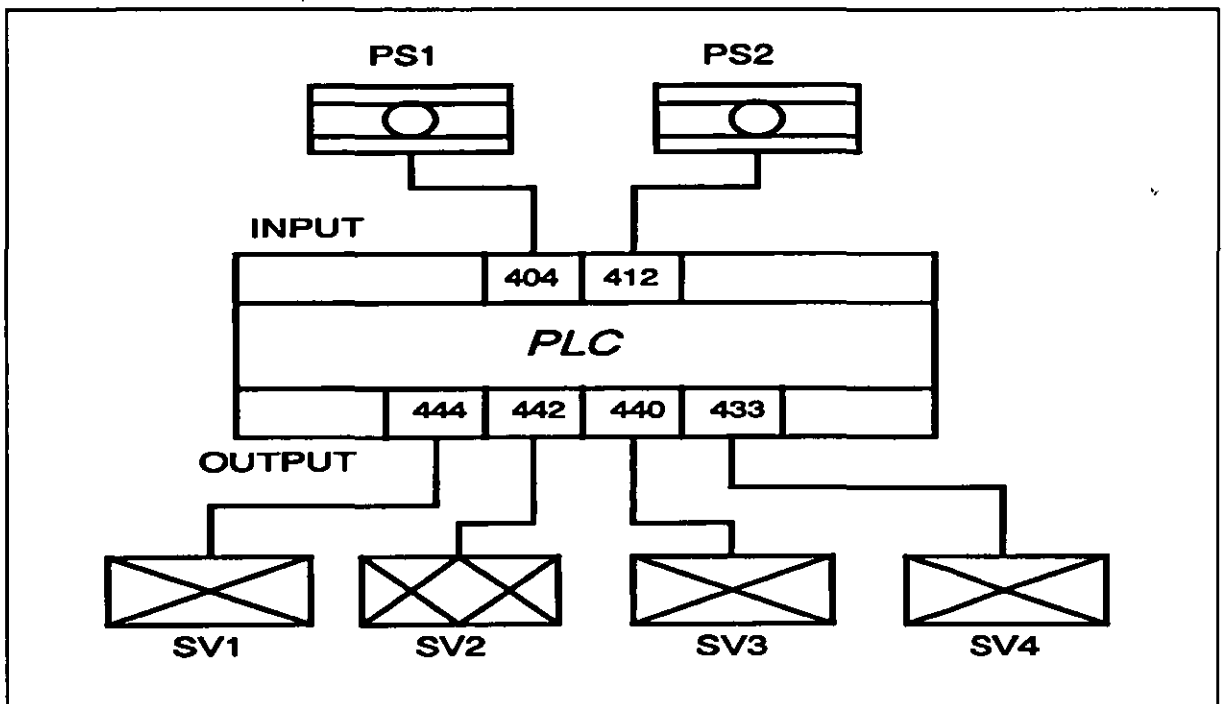

Figure 5.3: Wiring of the PLC for controlling the loading station

In the 'waiting for next workpiece carrier' condition of the loading station all the SV's are OFF. This positions both cylinders in the reset condition (Chapter 3.2.1). The sequential control action of the loading station is shown in Figure 5.4.

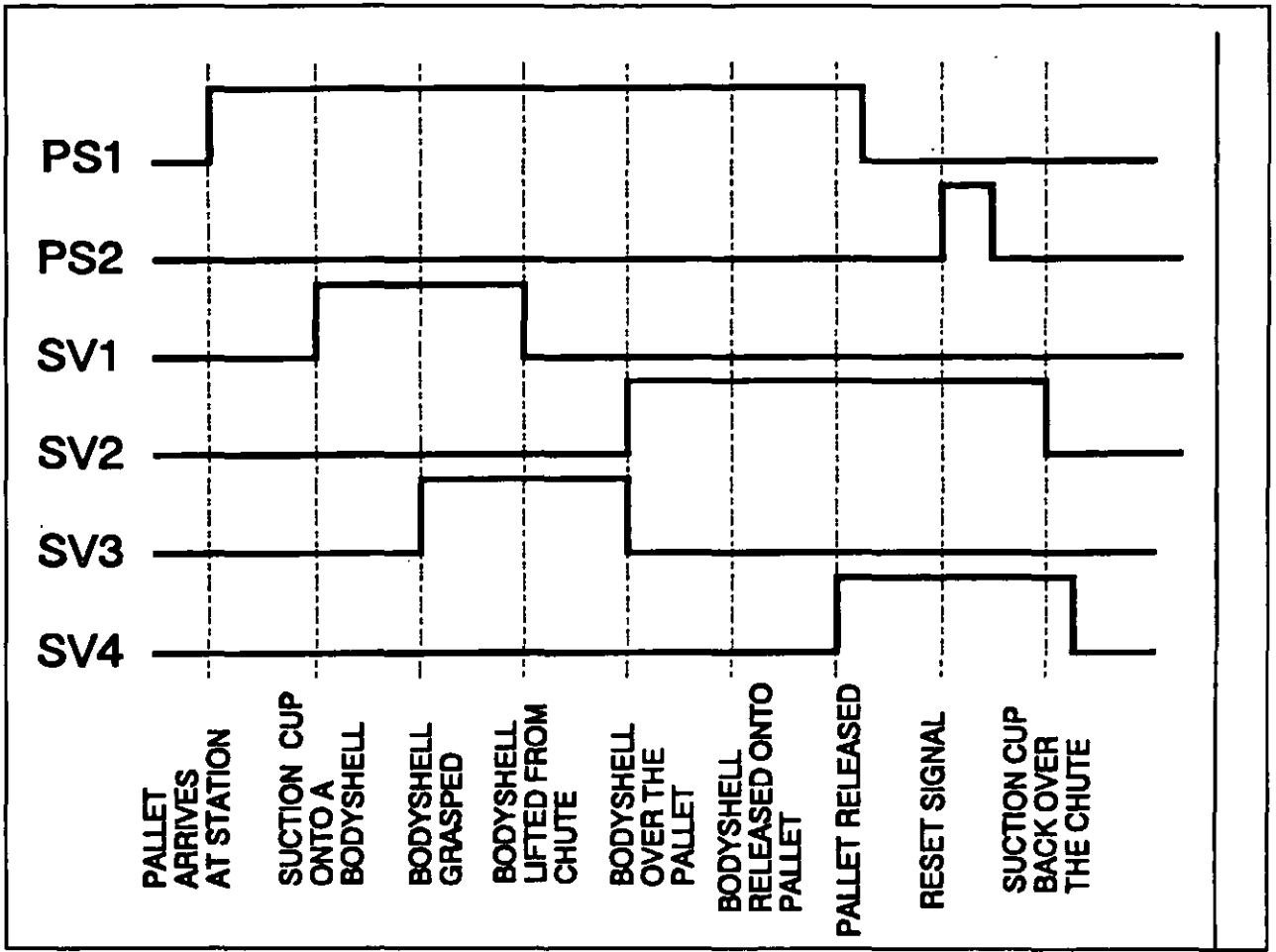

Figure 5.4: Sequential control of the loading station.

5.4.1.2 Monitoring the bodyshells.

The necessity for monitoring the presence of the bodyshells is twofold:

- a) there might not be a bodyshell at the bottom of the loading chute or
- b) the bodyshell might be dropped before the sequence is completed³.

It was decided to monitor both conditions using a single sensor attached to the end of cylinder A as close as possible to the vacuum cup (Figure 5.5).

³ The reason for this last problem can be further broken down into b1) is it a mechanical problem? or b2) is it an air failure? This and the other error recovery routines will be discussed in Chapter 6.

The sensor used is an Reflective Opto-Switch and its operational principle is shown in Figure 5.6. The output from an reflective opto-switch depends upon the distance d between the switch and a reflective surface represented by $d_{critical}^4$ in Figure 5.6.

The initial trials with the sensor produced satisfactory results only with light coloured bodyshells. This was due to the high absorption of the infra-red by the dark bodyshells preventing the phototransistor from triggering reliably. Running the diode at maximum current did produce a slightly better response but not one that could be relied upon.

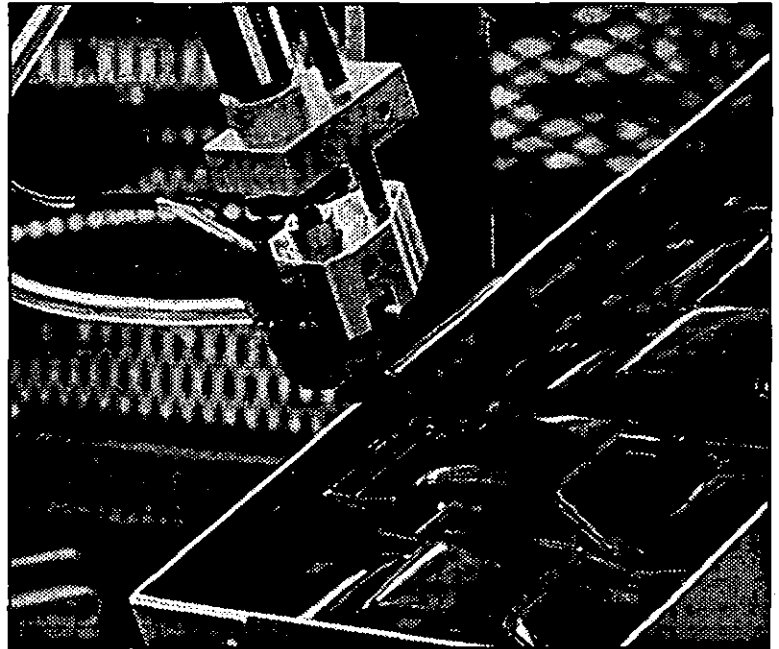

Figure 5.5: The sensor fitted to the end of cylinder A.

It was decided to pulse the diode current to a high value so as to increase the sensitivity with dark colours; the circuit is shown in Figure 5.7. This solution proved to be very successful and the sensor can now be used with a whole range of colours.

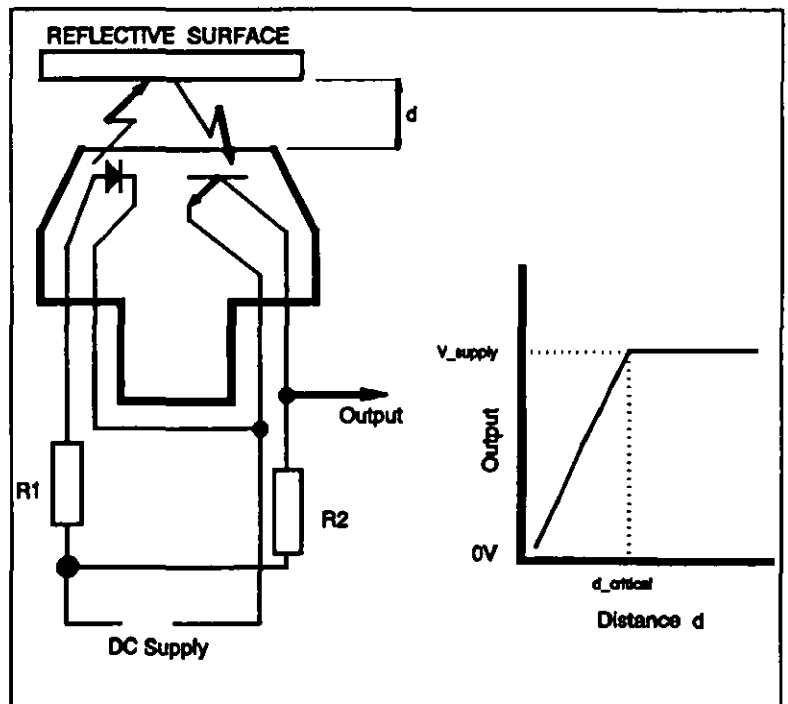

Figure 5.6: Principle of operation of the reflective opto-switch.

⁴ 5.4 millimeters for the switch used in the sensor with a 90% reflective surface.

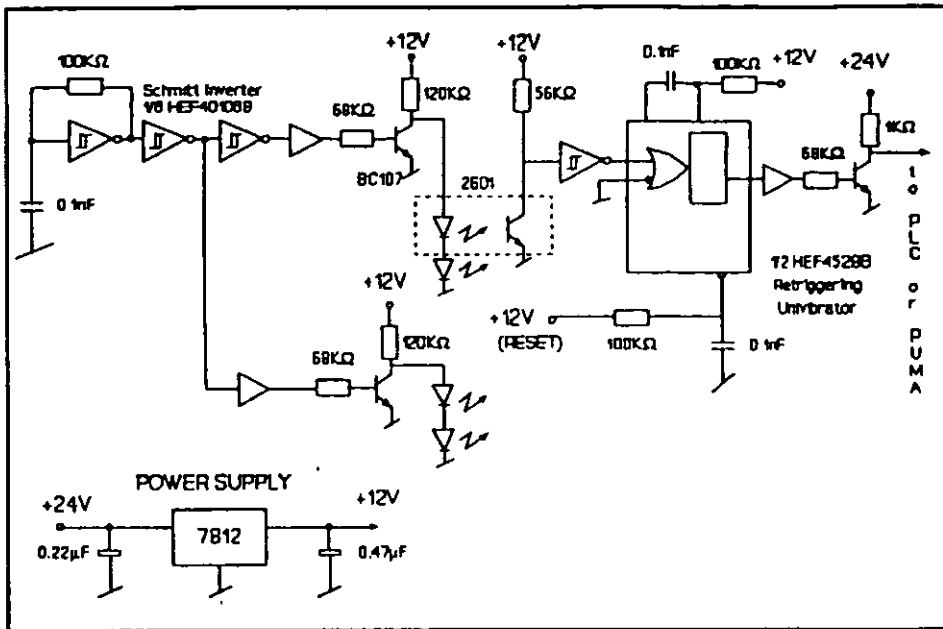

Figure 5.7: Circuit used to boost the sensitivity of the reflective opto-switch.

5.4.2 Identification station.

The control requirements of this station are:

- stop and release the pallets at the station
- control the voltage level to the bulbs in the side-lighting unit
- switch the bulbs **ON** and **OFF**
- inform **EAGLE** that a workpiece carrier is at the identification station
- photograph and analyse the contents of the workpiece carrier.

The schematic of the wiring for all but the last requirement is shown in Figure 5.8. **PS3** is used to inform the **PUMA** robot that a workpiece carrier is at the identification station and is also linked to the **PLC** so that the next workpiece carrier can be stopped before it enters the station. **SV5** is the stop gate in the station.

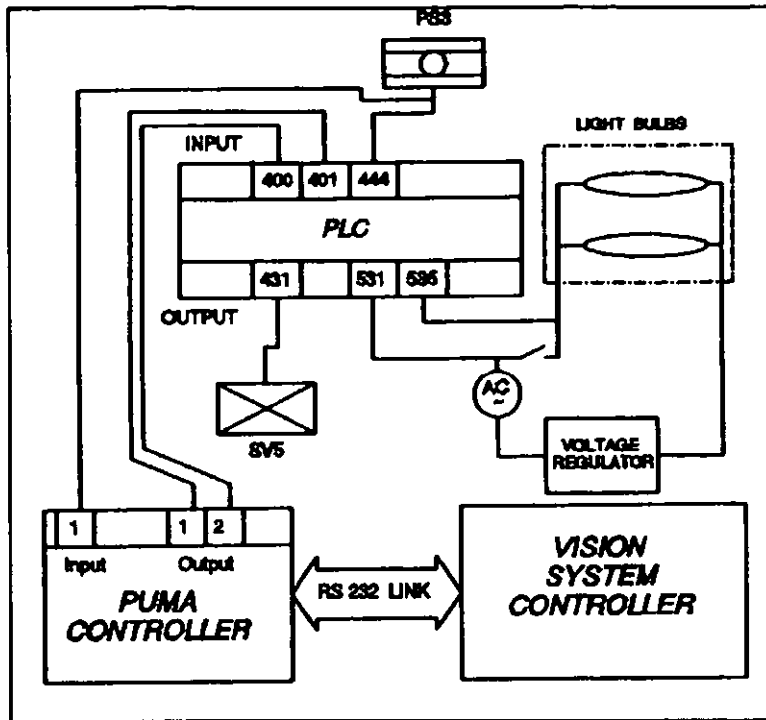

Figure 5.8: Wiring at the identification station.

5.4.2.1 Control of the station.

The sequential control of the station is triggered when a workpiece carrier arrives at the identification station and the PUMA robot is in position⁵ over the identification station. Figure 5.9 summarises the control actions at the identification station. For the purposes of the example the PUMA robot is assumed not to be at #PICTURE at the start of the sequence.

5.4.2.2 CCD camera connection to the vision system.

Although the CCD camera connection is a straightforward procedure as can be seen in Figure 5.10, there are three ON/OFF operating controls in the camera power supply which affect image quality and therefore need to be set correctly. They are the Aperture Gain Control (AGC), the Aperture Control (AP) and the Gamma control⁶ and their functions are as follows:

⁵ This is a pre-defined location in EAGLE and will be referred to as #PICTURE from now on.

⁶ Gamma is the slope of the line when camera output is plotted against light intensity on a log/log scale.

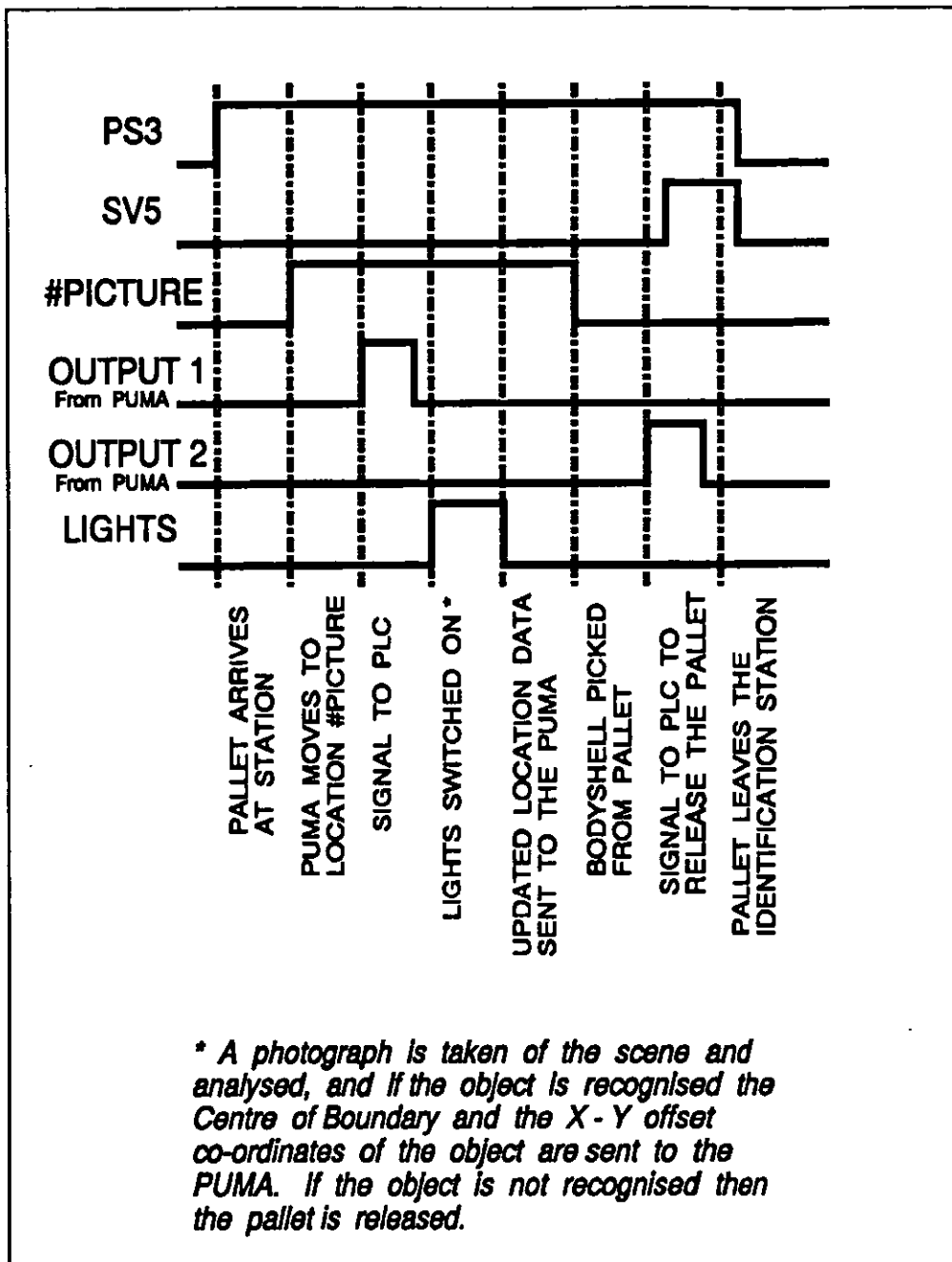

Figure 5.9: Sequential control of the identification station.

- AGC compensates for low light levels when switched ON
- AP enhances the edges of objects when switched ON
- Gamma is set to 0.6 when switched ON and 1.0 when OFF.

To determine the correct setting of these controls a simple experiment was carried out using the edge and feature detection factors of the vision system and a range of bodysells of different

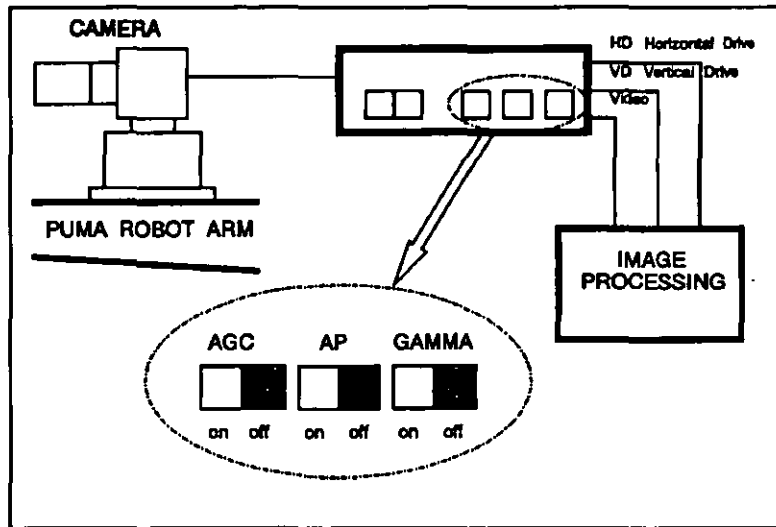

Figure 5.10: The CCD camera connections and control settings.

colours. The edge and feature detection factors determine the maximum and minimum threshold values used to transform grey images into binary. As the names suggest the edge detection factor picks out the outer boundary of an object and the feature the internal features within that boundary.

The experiment consisted of finding the best combination of switch settings that would keep the edge and feature detection factors constant for as large a range of different colour bodysells as possible. This experiment was repeated with different levels of illumination to ensure that the best overall level of compromise was achieved.

It is extremely important to be able to keep the edge and feature detection factors constant as it allows for accommodating a considerable number of different models in each library⁷. The best combination of the ON/OFF switch settings is shown in Figure 5.10.

5.4.3 Decorating station.

The main requirement of this station was the interaction between the PUMA robot and the pad

⁷ In the context of computer vision, a library is a file which contains statistical data of the objects within that file.

printing machine. The required sequence of events was:

- when the robot was not positioned at the printing machine, it would always be in the sweep cycle
- when the robot is ready to position the matrix in front of the printing machine, the sweep cycle would be stopped with the arm to the back of the machine
- one print cycle would then be activated and when finished the robot would move the matrix away
- the sweep cycle would be restarted.

Initially the print cycle would be manually selected from the 28 programmes stored in an EPROM on the control board in the printing machine.

One possible way to achieve the interaction between the robot and printing machine would have been to modify this control board, but after consultation with the manufacturer this solution was ruled out. The only solution left was to mimic the required switches on the printing machine in software using the I/O ports on the PUMA controller. Figure 5.11 shows the connections for one switch while Table 5.3 lists the switches on the printing machine and the I/O port number on the PUMA controller.

During the initial trials of the robot/printing machine interface a problem was experienced with the timing between them. A typical example was that the printing machine would not stop when requested to do so by the software. A consequence of this was that there would often be a contact between the pads and the matrix/bodyshell before it was positioned correctly.

When the printing machine was being manually operated this problem of not stopping instantly was also apparent. The problem was found to be that as the doctor blade/spatula carrier is driven by an air cylinder the on-board electronics would not stop it after the 'stop' signal was received before it got to one of the limit switches. The probability of the software activating the stop signal when the arm was touching one of the limit switches was very low.

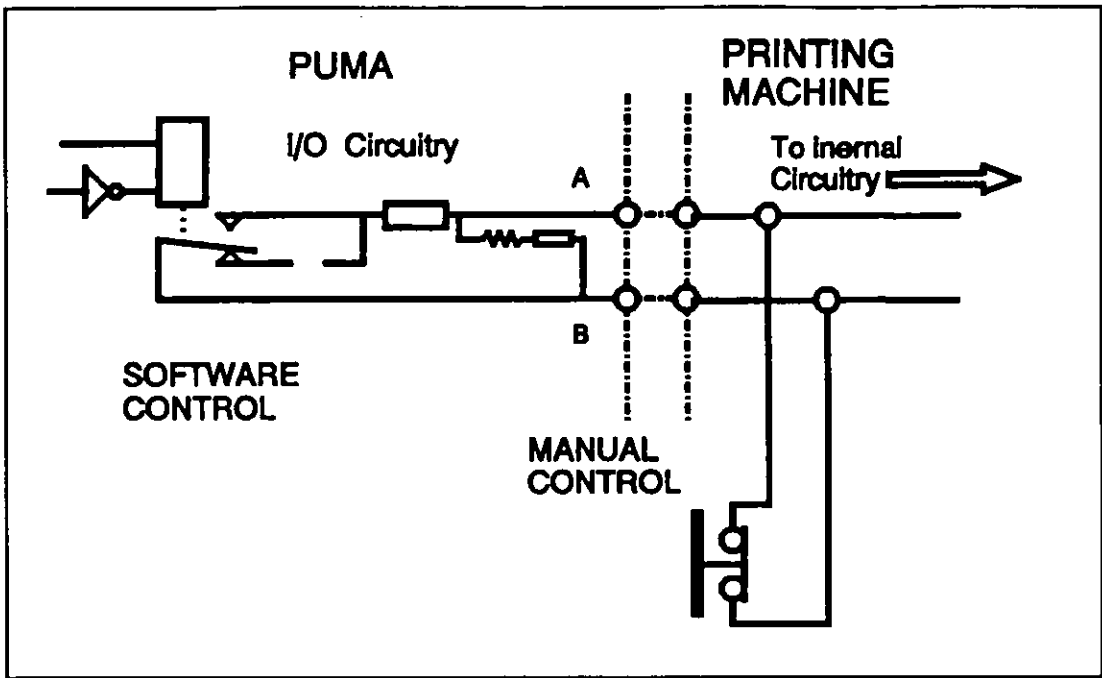

Figure 5.11: The wiring connections between the PUMA controller and the printing machine.

Table 5.3: The printing machine switches controlled by the PUMA controller.

PRINTING MACHINE SWITCH	I/O NUMBER
Start Switch	8
Pad stroke	9
Programme selector	10
Stop Switch	1

The solution to this problem was to duplicate the limit switches and fit an extra switch over the print position so that the position of the doctor blade/spatula carrier could be monitored. This way the stop signal could be maintained until the carrier had come to rest.

5.4.4 Inspection station.

The control requirements of this station are:

- connectin of the camera to vision system
- interaction with the PUMA robot for selecting the various parts of the bodyshell to be inspected
- communication with the unloading station.

5.4.4.1 Camera connections.

Because the same vision system is used by the identification station, the realisation of this camera connection was simple. It was decided that all the movements to inspect the three areas of the bodyshell should be carried out by the robot, therefore cheaper but less robust tube cameras could be used. Another advantage is that they do not need special power supplies as do CCD cameras.

5.4.4.2 Interaction with the PUMA robot.

At the inspection station, the movements of the PUMA robot are carried out under the supervision of the vision system. For example, after analysing the first area of the bodyshell, the vision system will send data to the PUMA controller to tell it to either move the bodyshell to the next location if it has passed the first inspection or to had it to the RTX robot if it has failed. The PUMA controller will send data back to the vision system to say that the movement has been completed.

All communication is via the RS-232C serial links.

5.4.4.3 Communication with the unloading station.

The result of the inspection routine, (pass) or (fail), is sent to the unloading station via the RS-232c serial link. This is done via the PUMA controller i.e. the vision system sends the data to the PUMA controller which in turn transmits the data to the RTX controller at the unloading station. The reason for this rather tortuous route is that there was only one serial port supplied with the vision system and no way to fit another.

5.5 UNLOADING STATION.

There are only two requirements at this station:

- interaction between the PUMA and RTX robots
- control of the suction cups on the RTX robot end-effector

5.5.1 Interaction between the PUMA and RTX robots.

Signals are necessary to synchronise the movements of the RTX and PUMA robots as there workspaces overlap. For instance it is necessary to ensure that the RTX robot would not move from its grasp position until the PUMA robot had left the unloading station (ROBOT_TRAFFIC Figure 4.7). Again this is transmitted via the serial link between the two controllers.

5.5.2 Control of the suction cups.

This control is executed via the PLC since the only control needed is that of the SV,s linked to the suction cups. Initially only one SV was used to control all five suction cups of the RTX robot end-effector. This worked well when picking up the palletising trays as all five suction cups were used. However, when just the central one was used to grasp the bodyshell there was insufficient vacuum generated as the air leakage from the four outer cups caused the air pressure to the central cup to drop.

The solution to this problem was to use two independent SV's, one to control the outer four to lift the pallets and one to grasp the bodyshells. Figure 5.12 shows the necessary links to operate the unloading station.

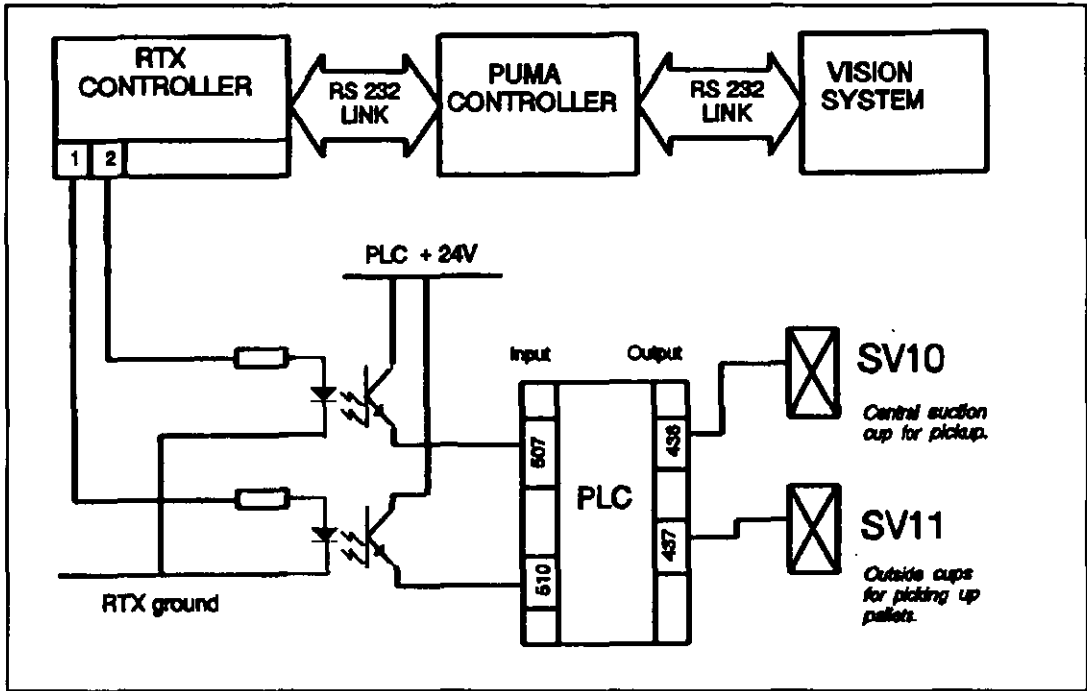

Figure 5.12: Wiring of the unloading station.

Opto couplers were used in the interface between the RTX controller and the PLC to isolate the RTX controller from the 'high' voltages associated with the PLC. No such interface was required between the PUMA controller and the PLC as they both work at the same voltage of +24V.

CHAPTER 6:
THE OPERATION OF THE CELL.

6.1 SUMMARY

Chapters 3, 4 and 5 presented the design of the proof-of-concept-cell through the component parts of each station. The Mechatronic design methodology used has ensured integration of each station into the whole; this is highlighted in the operation cycle of the cell described in Section 6.3.

The operator interface is described in the start up procedure of the cell. A knowledge based system is being developed to hold the relevant information about the cell operation and it is envisaged that this will be able to be used by an operator in the form of a consultation session as well as acting as the overall cell controller.

A relatively simple cell control philosophy with embedded recovery strategies is described in Section 6.4.

The flexibility of the decoration cell is discussed in Section 6.5 along with possibilities for a modular cell.

6.2 OVERVIEW OF THE OPERATION OF THE CELL.

A schematic layout of the proof-of-concept cell is shown in Figure 6.1. All the items except the moulding machine are installed at the Department of Mechanical Engineering and are operational. It is important to mention that to fully decorate the model being used to develop the proof-of-concept cell seven Tampo printing machines would be required for a flow-line operation. Obviously Hornby Hobbies could not spare this number of machines so only one is actually installed in the cell.

6.2.1 Work cycle.

The work cycle of the proof-of-concept cell is described following the various stages through which an undecorated bodyshell goes through: after leaving the moulding machine the

bodyshell is inspected for flaws and 'flash', it is then conveyed to the loading station where it is stacked. The loading mechanism transfers it to a workpiece carrier and it is conveyed to the identification station where the CCD camera mounted on the PUMA robot is used to analyse the contents of the workpiece carrier. The vision system sends the PUMA controller information regarding the centre of boundary of the bodyshell so that the PUMA robot can grasp the bodyshell.

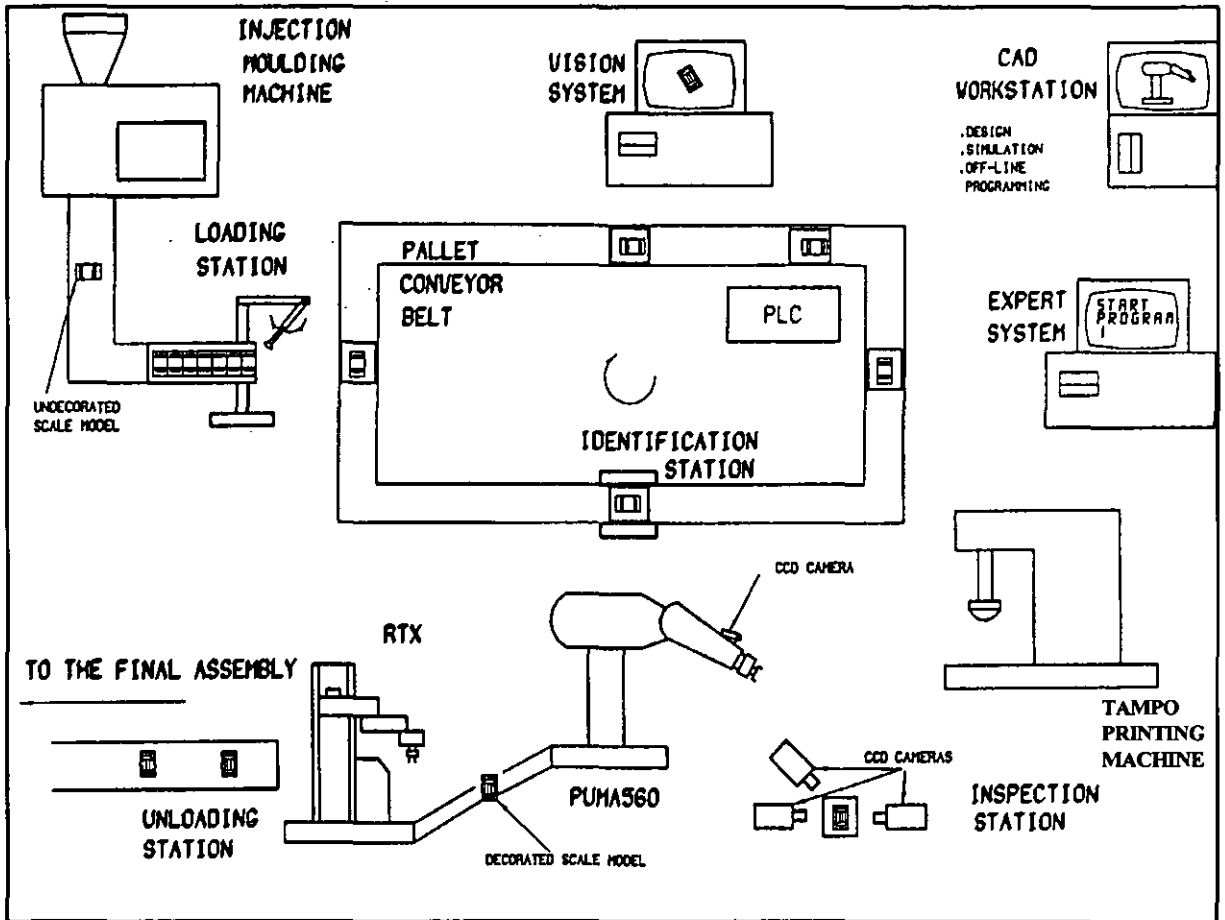

Figure 6.1: Schematic layout of the proof-of-concept-cell.

The bodyshell is placed in the repositioning device, the PUMA robot changes the end-effector and places the bodyshell on the matrix. The decoration process is carried out by the interaction of the PUMA robot with the Tampro printing machine. In the approach adopted the printing machine is stopped, the PUMA robot places the matrix at the first print position and the printing cycle is then started. As the printing machine is controlled by the PUMA controller the interaction between them during the decoration process was relatively easy to control. When all the

¹ Excess plastic left on the model after moulding.

decorations at the first machine are finished the PUMA robot moves to the second machine and so on.

When all the decorations are completed the PUMA robot transfers the matrix to the inspection station and the bodyshell is inspected. Finally the bodyshell is handed to the unloading station where the RTX robot will palletise the bodyshell if it has been accepted by the inspection routine or place it in a reject bin for possible rework or scrap.

6.3 OPERATION OF THE CELL.

6.3.1 Start up procedure.

Section 6.2 described the on-line operation of the cell, this section describes the requirements of an operator to initialise the work cycle of the cell. This requirement will be referred to as the start up procedure from now on. For the purposes of this description it is assumed that the printing machine had already been set up and the identification and inspection databases generated. It is described as follows:

First the operator switches on the mains electricity supply to the following;

- PUMA controller and PUMA robot
- RTX controller and RTX robot
- Tampo printing machine
- conveyor system motors
- vision system controller and cameras
- PLC and associated power supply

- Voltage regulator² of the inspection station.

Next the air supplies to the various parts of the cell have to be connected and the pressures set according to the values shown in Table 6.1.

Table 6.1: Air supply pressure to the component parts of the proof-of-concept cell.

CELL COMPONENT	PRESSURE (bar)
Printing machine	6
Conveyor system	4
PUMA robot	3
RTX robot	6

If required, the operator will first run the calibration routines to set the PUMA-vision calibration factors and then execute the programme **EAGLE**. **EAGLE** controls the actions of the PUMA robot at the identification, decoration, inspection and unloading stations as described in Chapter 4. However it also contains the sequential control of the whole proof-of-concept cell. This will be described in Section 6.4.

Next, the programme **EAGLE** prompts the operator to run **OWL** which controls the vision system. The initial interaction between the two programmes is to check the RS-232 link between the two computers, this is shown diagrammatically in Figure 6.2., if this check is successful the operator is then prompted to run **PUFFIN** which controls the RTX robot. As with **OWL**, the initial operation of **PUFFIN** is to check the RS-232 link with the PUMA controller. This is carried out in exactly the same way as for the vision system/PUMA controller and if successful the RTX robot will be calibrated via the built in initialisation routine and then be driven to the 'safe' location **ABOVE_PUMA** (Figure 4.7) from where it will take the bodysells from the PUMA robot.

² The regulator voltage is set during the training process.

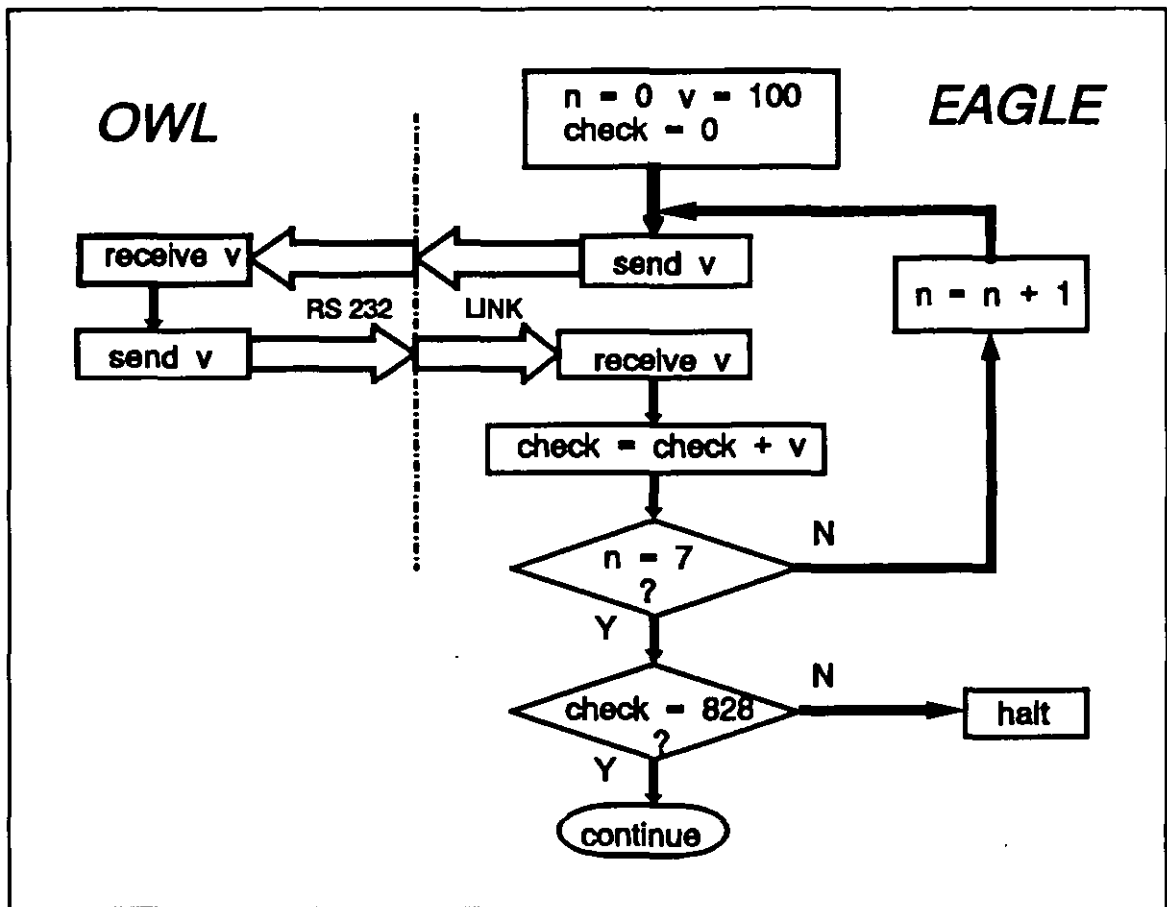

Figure 6.2: PUMA-vision system RS-232 check.

EAGLE then prompts the operator to switch on the conveyor system motors, the printing machine and the cameras and monitor. Finally the operator is prompted to select the model to be decorated. This is done via EAGLE and this information is sent to OWL so that the relevant database of model information can be loaded for the identification and inspection routines to use.

Beyond this the operator has no further control as the PUMA controller takes over the sequential running of the cell. The PLC is switched on, the printing machine is operated in 'sweep' mode and OWL is run up to the point where it waits for the PUMA robot to get to location #PICTURE³ and a workpiece carrier to arrive at the identification station. The programme PUFFIN drives the RTX robot to remove the top pallet from the 'empty' stack and place it at the palletisation position and then return to the safe location ABOVE_PUMA. The on-line

³ The location in the identification station above the workpiece carrier.

operation described in Section 6.2 then takes place.

After executing the start up procedure of the cell a number of times the operator will become familiar with the sequence of events to be followed. It was felt, however, that some form of aid would be helpful especially with operators unfamiliar with the cell. This could simply have taken the form of an operators manual with all the various settings listed, but unless this was written very carefully it could become extremely difficult to follow. The approach adopted, however, was to develop a knowledge base which contains all the information relevant to the operation of the cell. This could be used in the form of a consultation by the operator and the information supplied graphically on a computer screen.

The expert system Savoir {Intelligent Systems, 1987} is being used for this purpose. This application, along with other future developments of the cell will be described in Chapter 7.

6.3.2 Operator interface.

The largest part of the interaction between the operator and the decoration cell takes place in the start up procedure described above. During the on-line period of operation, operator intervention will only be required during 'emergency' or non-programmed conditions. The reason for the emergency may be an irregularity in the decoration cell that is potentially damaging to the equipment in the cell.

Such an irregularity might be that a bodyshell has not fitted onto the matrix properly. This could cause problems at the Tampo printing machine during the printing cycle. In this case the operator would need to interrupt the operational cycle of the cell until the situation was corrected. This can be achieved by one of the following means:

- **Putting the PUMA controller into PAUSE.** This will only stop the motion of the robot and not affect any other function in the programme.
- **Individual emergency stop switches** (also known as panic switches) located at the component parts of the cell.

- **Global emergency stop switch** which halts the operation of the whole cell except the conveyor system. This is linked to an interrupt routine in EAGLE which will bring the cell to a stop in an orderly and controlled fashion.

6.4 CONTROL OF THE CELL.

The cell controller is EAGLE, a programme written in VAL II on the PUMA controller. The PLC handles all the operations relating to the conveyor system and the loading station, and the vision system and the RTX robot have their own controllers, but the cell controller can override them whenever necessary. This also applies to the PUMA controller itself, i.e. a task being executed by the PUMA might be interrupted by the cell controller even though the source of both is the PUMA controller. This is possible because of the different levels of interrupt calls from the VAL II language. A VAL II interrupt has the following structure:

REACT <signal>, <routine>,<priority>

Priority defines the hierarchy level of the routine between the minimum and maximum limits of 1 and 127. When a programme is written it is assigned the default level of 1. Suppose that a programme has the following line in it:

REACT 1010, shutdown, 127

In parallel with the execution of the main programme the robot controller constantly monitors signal 1010. When it goes high the controller interrupts the execution of the main programme (priority normally 1 or any sub-routine or interrupt with a priority level less than 127) and executes the sub-routine **shutdown**. When the execution of this programme is finished the PUMA controller resumes the execution of the interrupted programme.

6.4.1 Recovery strategies.

In order to achieve as low a level of human intervention as possible in the decoration process, the control programme has embedded recovery strategies which are triggered as soon as sen-

sors indicate that a non desired sequence has taken place. Some researchers would call this an error recovery strategy; the author, however, prefers to avoid the word error. It is believed that if one can actually plan to sense an error and recover from it, then it is not an error at all {Trabasso et al, 1990b}. These are simply events in a plan and are referred to as deviation events from now on. The events that lead to the desired event are referred to as goal events. At the loading station, for example, the goal event is to take a bodyshell from the loading chute and place it on a workpiece carrier. A possible deviation event is if the bodyshell is dropped before it reaches the workpiece carrier.

The recovery strategy presently adopted is to embed sensing steps and conditionals into the control programmes. Even though this strategy can be regarded as an ad hoc one it was chosen because the task of identifying possible deviation events in the decoration process produced a significant number of situations from which the control programmes could actually recover.

The framework of the recovery strategy is described as follows: each station has sensors to indicate the presence of deviation events. These sensors are referred to as deviation sensors in order to differentiate them from the rest of the sensors used in the cell. At some stations the deviation sensors have a physical configuration, for example the opto switch in the loading station (Figure 5.5), while at others it is a piece of software as will be described later.

An example of recovery action is given below. It is taken from the loading station shown in Figure 6.3. Note the deviation sensor attached to cylinder A, this is the opto switch described in Chapter 5.4.1.2. Suppose that the loading mechanism is holding a bodyshell in position P_1 . In this case the output of the deviation sensor (DS) is TRUE. The recovery programme acknowledges that DS should stay TRUE until the mechanism gets to point P_2 , where the bodyshell is loaded onto the workpiece carrier.

If the bodyshell is dropped before reaching point P_2 the DS output will read FALSE and trigger an alarm to the control programme. The control programme will release the workpiece carrier and try to identify the cause of the problem by seeking answers to the following questions:

- a) is it a global air failure of the decoration cell?
- b) is it a local air failure at the loading station?

c) is it a mechanism failure?

If the answers to (a) or (b) are **TRUE** the software will trigger an alarm to call for maintenance as this is an example of a true error, an error that the programme cannot recover from. If on the other hand the answers to (a) and (b) are **FALSE** the programme can conclude that (c) is **TRUE** and will drive the mechanism to the rest position and restart the loading cycle. If the error

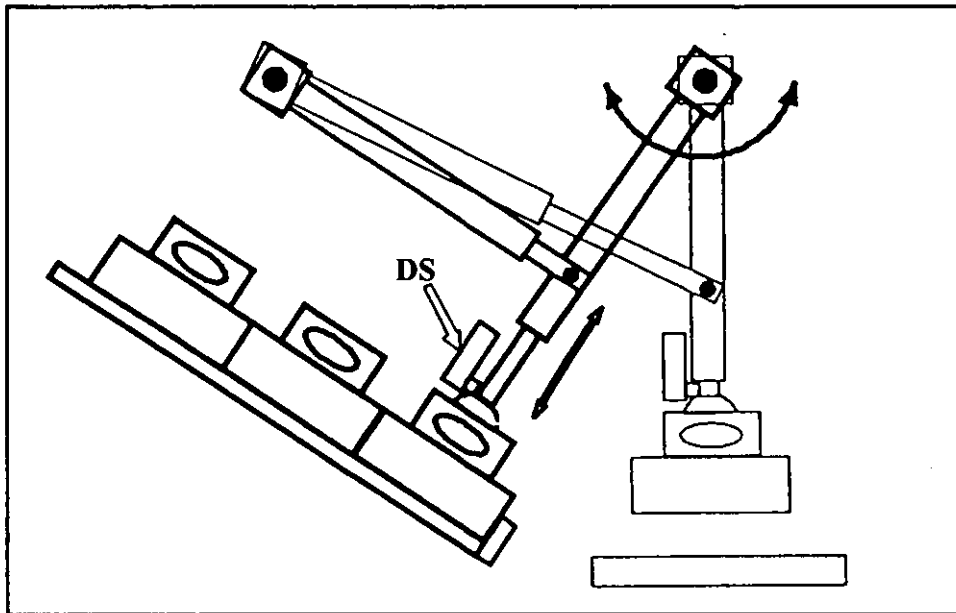

Figure 6.3: Recovery action at the loading station.

recurs then the software will call for assistance from the operator. Simple rules such as this can be easily drawn for all stages of the decoration process.

It was mentioned that some **DS** do not have a physical configuration, rather they are pieces of software. This is the case at the decoration station. The operation of positioning the matrix at the printing machine by the PUMA robot is essentially that of putting a peg in a hole as shown in Figure 6.4.

When the robot starts moving from P_1 to P_2 , a subroutine samples the distance d_1 at time t_1 . At time t_{1+k} the distance d_{1+k} is also sampled and compared with d_1 . If d_1 is equal to d_{1+k} the subroutine notes that the arm did not move between the two time intervals, for example because of contact between points P_3 and P_4 , and immediately takes the recovery action of moving the arm back to position P_1 . In this case this first step has to be taken before the inbuilt firmware routines are triggered, otherwise the PUMA controller could trigger one of its *fatal error* routines bringing the cell to a halt in an indeterminate manner. Only after this initial action does

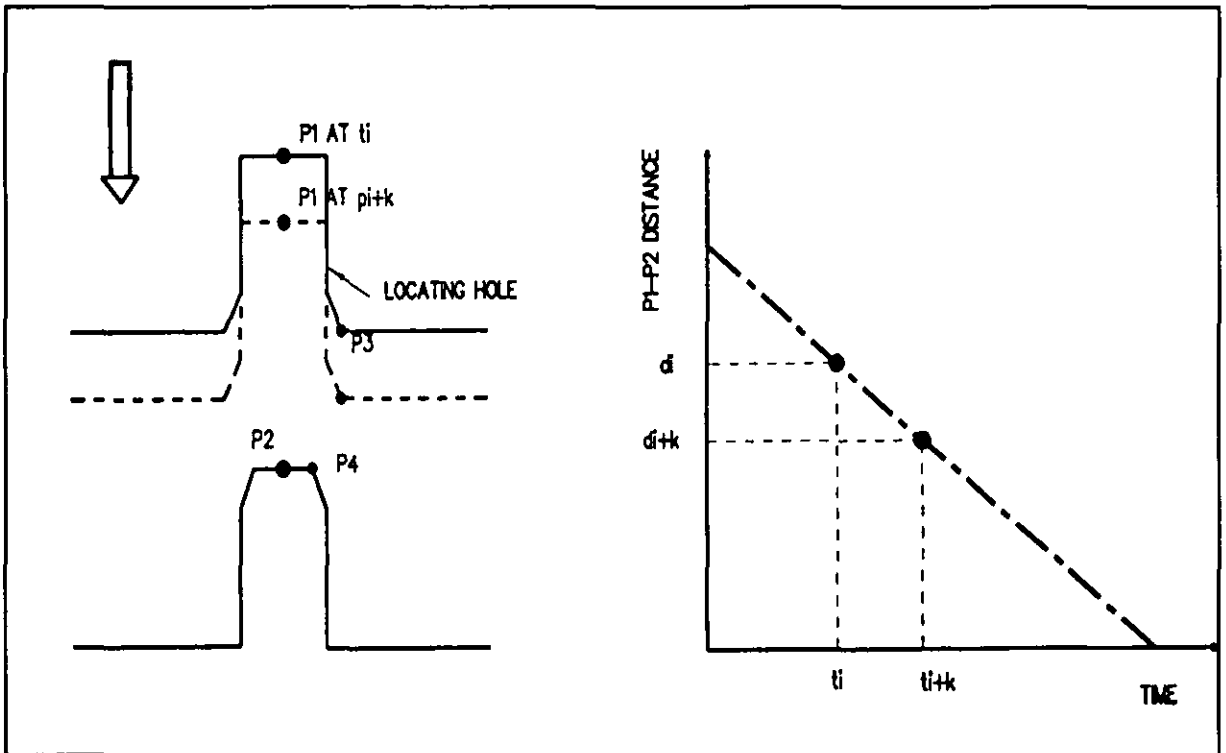

Figure 6.4: Recovery action at the decoration station.

the subroutine inform the main programme of its status so that complementary recovery action can take place.

The most likely reason for contact between points P_3 and P_4 is positional tolerance of the robot, rather than relative movement of the robot or printing machine bases. The recovery programme

directs the robot to repeat the operation keeping the original locations for P_1 and P_2 , if there is another failure the recovery programme redefines P_2 , within pre-defined limits, and directs the robot to try again. A third failure and the programme will signal that there is an error beyond its recovery capabilities and it will halt the current operation until the problem has been overcome.

Devices such as those just described, whose purpose is error free operation, are perfect examples of what the Japanese term 'poka-yoke'. Poka-yoke translates into 'mistake-proof'. Shingo {1986} describes many examples of such devices and systems. The design of these devices is a perfect example of simple and effective Mechatronics.

6.5 FLEXIBILITY OF THE CELL.

Scale model decoration is a process which demands great flexibility in production. This is because sponsors names, numbers and colour schemes are frequently changed from one season to the next. One bodyshell can, therefore, have many different sets of decorations. There is also the possibility of customised decorations should a customer request these. The present factory based method is fairly flexible but the time required to bring a printing machine 'on-line' for a new decoration outweighs this flexibility.

The problem of making the decoration cell flexible was tackled through its design: flexibility is embedded in the Mechatronics approach to design. The result can easily be assessed by looking at the stations of the cell. All but the decoration station can be easily and quickly re-programmed to execute a new decoration. No special jigs were used so that much of the cell hardware remains unchanged when a different decoration or bodyshell is required. The majority of the modifications are in software: generating the new databases for the identification and inspection stations and re-teaching the robot locations at the printing machine.

In order to gain a clearer picture of the cell flexibility the scenario of a complete cell changeover to decorate a different bodyshell with different decorations is described. The following alterations to the decoration cell have to be carried out:

- i) AT THE LOADING STATION**
 - L1) Change the loading chute,
 - L2) Vertical adjustment of the handling mechanism.

- ii) AT THE IDENTIFICATION STATION**
 - ID1) Generate the pattern recognition database,
 - ID2) Change the matrix end-effector of the PUMA robot,
 - ID3) Teach the new matrix locations the PUMA robot.

- iii) AT THE DECORATION STATION**
 - D1) Set up the printing machines,
 - D2) Teach the new print locations to the PUMA robot.

iv) AT THE INSPECTION STATION

IN1) Generate the inspection database for the model,

IN2) Adjust the cameras.

v) AT THE UNLOADING STATION

U1) Change the pallets,

U2) Teach the palletising locations to the RTX robot.

With reference to Chapter 3.3 it will be recalled that the time required for setting up a printing machine is approximately 3 hours for each model or decoration change. This unfortunately means that item D1 prevents any attempt at a quick cell changeover. All the other items can be carried out quickly and the database generation can even be carried out off-line if need be. Using the simulation package **GRASP** the robot programming can also be carried out off-line, although there will always be some 'fine tuning' to be finalised on-line.

All these will only make sense, however, if a workable solution is found to item D1. In other words if the cell has to shut down for three hours while the printing machine is set up then there is plenty of time to carry out the other operations in parallel with this setting up.

6.5.1 Modular decoration station.

One way to speed up the decoration cell changeover would be to have the decoration station as a detachable module {Trabasso et al, 1991d}. Suppose that the cell is nearing the end of the batch for a particular model. At this time the printing machine or machines for the next batch could start to be set up so that when the first batch is finished those machines are removed from the cell and the new set *plugged* into it. In this approach the off-line programming of the robots does make sense, as the new locations could be taught at the same time that the cell is working on the present model.

CHAPTER 7:

AREAS FOR FURTHER RESEARCH

BALANCED CONFIGURATION DESIGN

APPRIMA - THE NEXT GENERATION
OF PAD PRINTING MACHINE

7.1 SUMMARY

This chapter deals with those topics and ideas that have developed from the Mechatronic approach to the design of the proof-of-concept cell.

It will not be, as the title may suggest, a list of vague ideas, but descriptions of positive improvements to the decoration cell. Some of these are already in the prototype stage while others have received considerable attention and thought. Others are operational but not yet linked into the decoration cell, as is the case with the start up procedure implemented in SAVOIR.

Some of the techniques developed are leading to other related areas such as assembly and also into unrelated areas such as surgery.

The final part of this chapter deals with a new research proposal, currently before the DTI and SERC, for the next generation of pad printing machine.

7.2 POSSIBLE IMPROVEMENTS TO THE PRINTING METHOD.

This section will deal with those ideas that have been assessed as worthy of further investigation or have received detailed examination and lead onto other possible techniques.

7.2.1 The PAINTER approach.

Main characteristic: matrix stationary and pads manipulated by the robot.

As shown schematically in Figure 7.1, by taking the matrix away from the pad printing machine and placing it on a raised stand enables the robot to get to all five sides of the bodyshell. Removing the printing mechanism from the pad printer allows the robot access to the cliché giving greater freedom in movement and placement, in that it is now no longer necessary for the bodyshell to be moved every time a new area has to be decorated. This idea has been taken a stage further in that by placing several pads on one holder the robot is able to decorate all the sides of the bodyshell in one continuous movement {Trabasso et al, 1990d}.

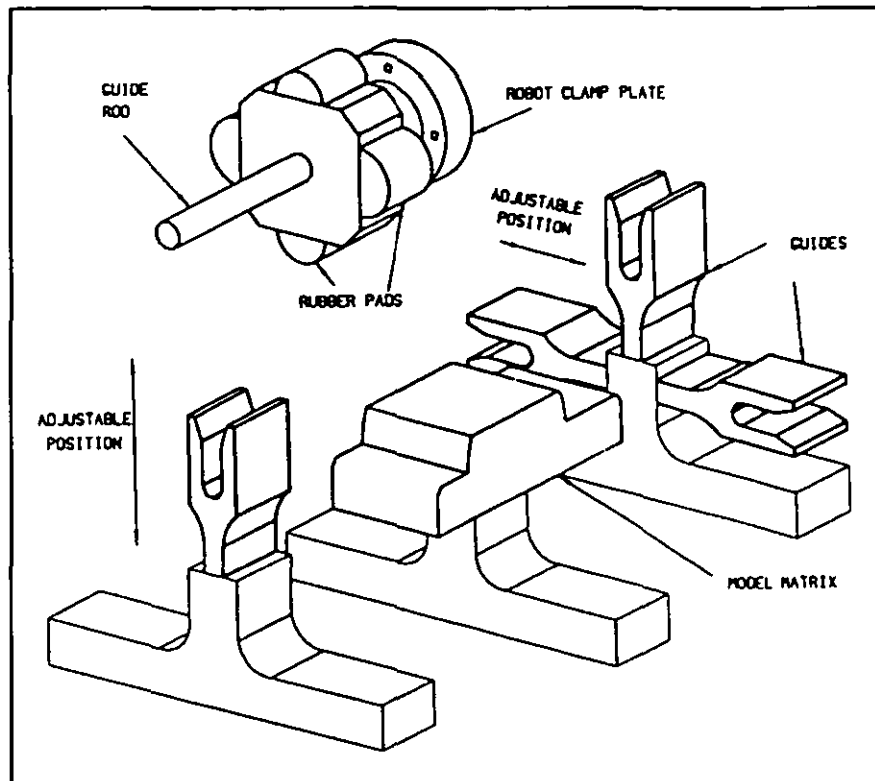

Figure 7.1: Schematic of the PAINTER approach.

To ensure the accurate placement of the decorations on the bodyshell, it was found to be necessary to provide some form of guiding device for the robot. The method chosen was to fit a guide bar to the front face of the mechanism and have this interact with an adjustable docking mechanism fitted to the base of the stand, so allowing one stand to be used for any bodyshell. As a further development the docking mechanism could be adjusted automatically as part of the set up procedure of the cell.

A prototype was built and successfully tested in that the robot could get to all the sides of the bodyshell. For instance, to decorate the two sides and the roof it was only necessary to describe a circular path centred in the middle of the matrix to move the robot round the bodyshell, and then use straight line motion to bring the pad into contact with the bodyshell. There are however two main drawbacks to this approach. They are:

- i) Drying time of the ink: the depth of the etch in the cliché is very small, usually 0.02 millimetres, consequently the ink tends to dry in around 5 seconds. This is one of the reasons why 'wet-on-wet' operations are possible in pad printing. By the time the robot has picked up all the decorations and transferred the pads to the bodyshell the ink is already nearly dry, mak-

ing successful transfer nearly impossible. The movement of the pads through the air only adds to the problem.

ii) Placement of locating devices on the printing machine: the same requirement for high precision (0.01 millimetres) at the printing machine makes it necessary to have a similar docking mechanism to that at the print position. This docking mechanism would have to be retractable so that the doctor blade mechanism could wipe the cliché.

There is a potential solution to the first problem in that modification to the ink consistency or composition could increase the drying time. The second problem is more complex however, with no clear solution as yet. The main difficulty is that there is very little room on a standard printing machine to fit this sort of modification.

A scenario where this technology could be made to work is if all the decorations of the same colour for a particular bodyshell were on one cliché in pre-defined areas then the extra size of the printing machine could allow for the fitting of the necessary retractable guide units.

7.2.2 The peg-in-a-hole approach.

Main characteristic: pads attached to the print machine and the matrix manipulated by the robot.

In order to overcome problem (ii) above, another decoration approach was devised. In this approach the decorations are transferred to the silicone pads in the normal manner. After completing this sequence the printing machine holds the pads at the front of the machine in a fixed location, and the robot pushes the matrix/bodyshell against the pads. Figure 7.2 shows the principle of operation of this approach.

The location between the two parts is by rods on the printing machine and holes on the matrix holder, so that the decoration operation can be dealt with as the classic robot task of inserting a peg in a hole {Trabasso et al,1989}.

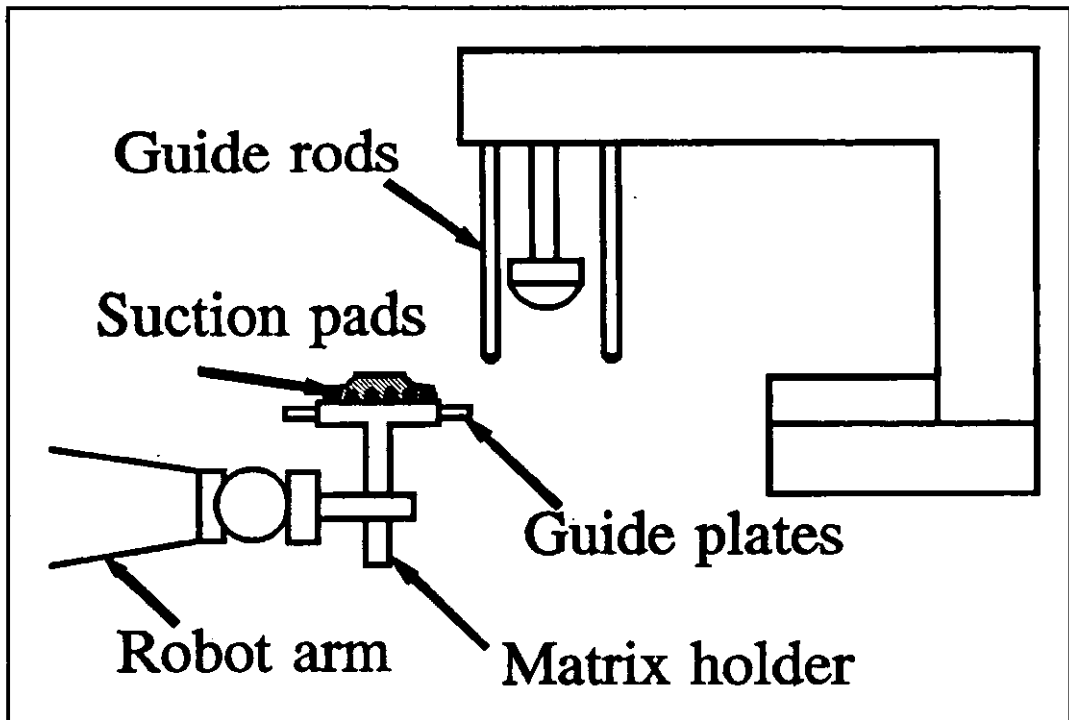

Figure 7.2: Schematic of the peg-in-a-hole approach.

To enable all the decorations to be printed the robot has to position the matrix in various orientations. Therefore, it is necessary to provide the matrix with some means of preventing the bodyshell from falling from the matrix whilst the robot is manipulating it and moving during the actual printing process. Creating a vacuum on the surface of the matrix via a number of Venturi tubes is a simple but effective solution to the problem.

Some bodyshells only require one decoration whilst others as many as twenty two. Even in the latter case the peg-in-a-hole approach could still be successfully applied, providing that an optimal location of the location of the robot with respect to the printing machines could be found.

Even though the principle of the peg-in-a-hole approach appeared sound, there was one part that had not been investigated and on which it was felt that the approach could possibly fail. This would also hold true for the painter approach, the pad pressure required to successfully transfer the decoration from the pad to the bodyshell. It was felt that only a direct 'push' by the robot arm along its Z axis could achieve the necessary force without deflection, and this would not always be possible.

This doubt led to the adoption of the actual approach used in the decoration cell. This is described below.

7.2.3 The revised peg-in-a-hole approach.

Main characteristic: pads attached to the printing machine and the matrix manipulated by the robot, and locating pegs attached to the worktable of the printing machine.

The main problem with the original version was the setting up of the printing machine. In order to test the print location and quality on the bodyshell the technician would also have to operate the robot which would make getting to the front of the printing machine to check the operation very difficult. To overcome this problem the locating pegs of the guiding device were trans-

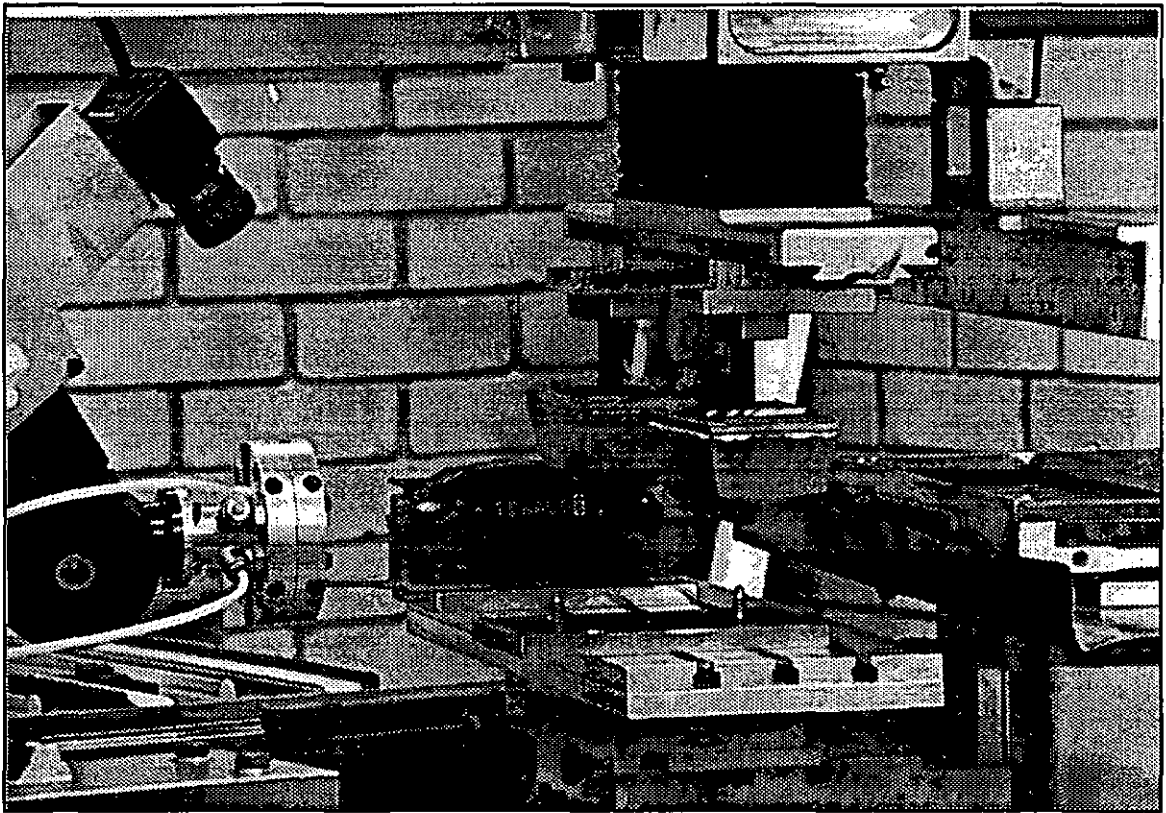

Figure 7.3: The revised peg-in-a-hole approach.

ferred from the original position on the printing machine to blocks attached to the worktable in front of the printing machine, and the guide holes to the bottom of the matrix unit {Trabasso et al,1991c} as shown in Figure 7.3.

The advantage of this method is that no force need be exerted by the robot nor is any exerted on it. This method does not require the technician to carry out any further operations than at present, as he has to fit the matrices to the worktable in front of the printing machine in the current factory method. There were two problems to this approach, though, in that it is not always possible to present a horizontal surface to the printing pads and there was no adjustment in the X - Y plane.

To overcome this a new adjustable baseplate was designed (Figure 7.4) so that the matrix unit could be tilted through a maximum angle of 40° ¹ should this be necessary. The adjustments in

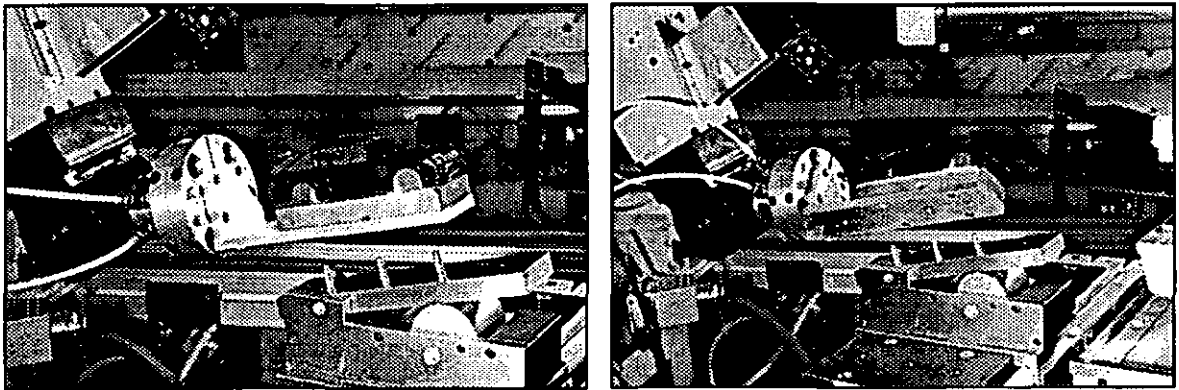

Figure 7.4: Modified peg-in-a-hole base unit.

the X-Y plane are now catered for by slots located in the bottom flange of the base unit and the angular adjustment by rotating a cam inside the base.

Another problem to be solved was to devise a method for the robot to position the matrix for all the possible positions for decoration. For printing the bonnet, roof and back of the car this presented no problem as it just meant moving along to the next set of locating holes. The sides could be done in the same way as all that is required is that the robot turns the matrix 90° for one side and -90° for the other. Obviously for these operations the base is set horizontal.

The difficulty is to print the decorations on the front and rear areas of the bodyshell (Figure 2.4 refers). The first idea was to attach the robot to the base of the matrix as this never decorated, and whilst this would work for the sides and ends of the bodyshell it presented difficulties for

¹ This angle was arrived at by measuring various bodyshells to check the variation in the inclination of the bonnet with respect to the roof.

the top faces. It was decided to try an alternative method.

This new method, shown in Figure 7.5, and referred to as the indexing matrix, gives the matrix the capability of rotation through an axis perpendicular to it. The rotation index for the present design is 90°. The principle as presently designed is purely mechanical in that the robot pushes the matrix against an auxiliary rod and then rotates the

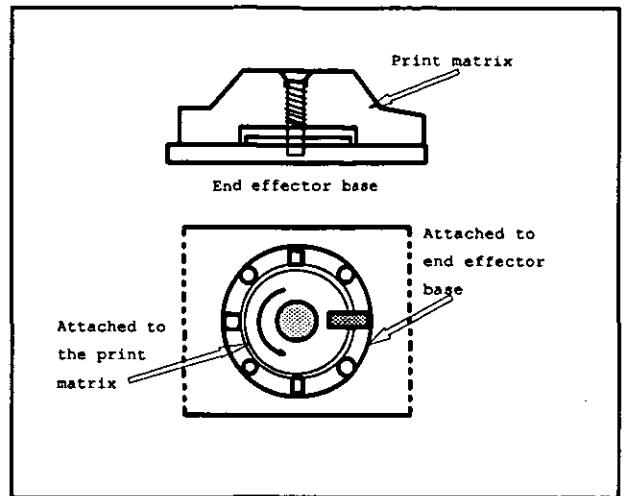

Figure 7.5: The indexing matrix principle

matrix the required number of notches. A mechatronics way would be to use a solenoid or stepper motor inside the matrix to rotate it relative to the robot end-effector.

7.2.4 Improvements to the revised peg-in-a-hole approach.

To arrive at the conclusion that the previous approach needs yet another improvement, it is necessary to look at the scenario where a bodyshell receives all the planned decorations. Suppose that this requires seven pad printing machines as is the case with the Texaco Sierra.

After printing the bonnet and roof at the first printing machine, for instance, the robot would move the matrix to the second printing machine to print the sides for example. Meanwhile the first printing machine is idle as are numbers three to seven. At any one time only one printing machine would be working.

The main concern is not the throughput of the cell, because even with this approach the two to three minutes to produce a fully decorated bodyshell is far better than the present factory time of two to three weeks. Rather it is that the full potential of the PUMA robot has not been achieved in this approach. A possible solution is the matrix-on-belt approach described below.

7.2.5 The matrix-on-belt approach.

A schematic of the matrix-on-belt approach is shown in Figure 7.6. One of the advantages of

this approach is that there are no modifications required to the printing machine other than that of removing the worktable at the front and replacing it with the matrix-on-belt unit.

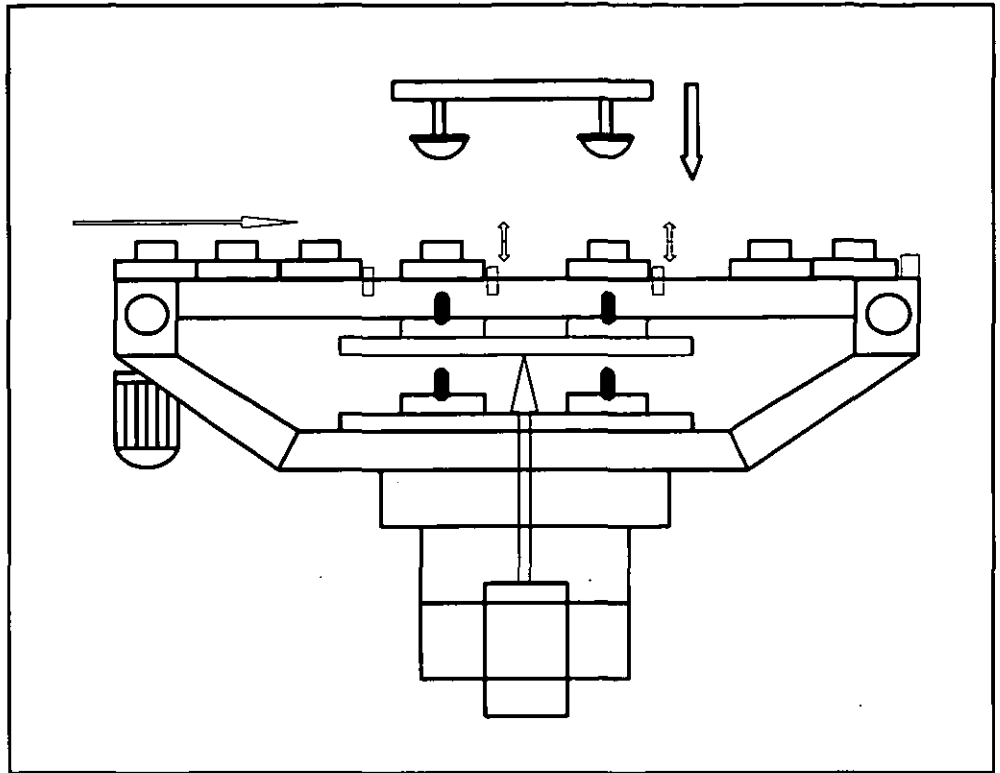

Figure 7.6: The principle of operation of the matrix-on-belt approach.

The principle of operation is as follows: the matrix/bodyshell units are loaded at the left hand side and they are carried across towards the right hand side by a conveyor belt. Stop gates hold the matrix units in position under the printing pads and they are then lifted up off the conveyor belt by a pneumatic cylinder which is locked in place. The printing pads then transfer the decoration to the bodyshell in the usual manner. The cylinder is released and the matrices are returned to the conveyor belt, the gates are opened and the matrices travel to the next location and the procedure is repeated.

When the matrix gets to the right hand side it is held in a buffer until it can be transferred to the next operation which could be further decoration at another printing machine or inspection.

With regard to the setting up operations, the cylinder would be raised and locked in position and the technician carry out the usual adjustments to the pads and doctor blade. The only extra job would be to set the gates on the conveyor belt when he was satisfied with the decoration position.

To perceive the benefits of this method one has to recall the scenario with seven pad printing

machines required to completely decorate the bodyshell. If each of the printing machines was equipped with matrix-on-belt unit then it is easy to visualise the matrices being loaded at one end and being transferred from printing machine to printing machine and finally to the inspection station. In the present scenario it is not necessary to employ a PUMA robot as specialised handling mechanisms could be built for the interchange between each printing machine.

It need not even be necessary to use a robot to transfer from the loading chute to the first printing machine if the orientation could be guaranteed before hand, it can only be one way round or the other, so that again a dedicated mechanism similar to the transfer mechanism

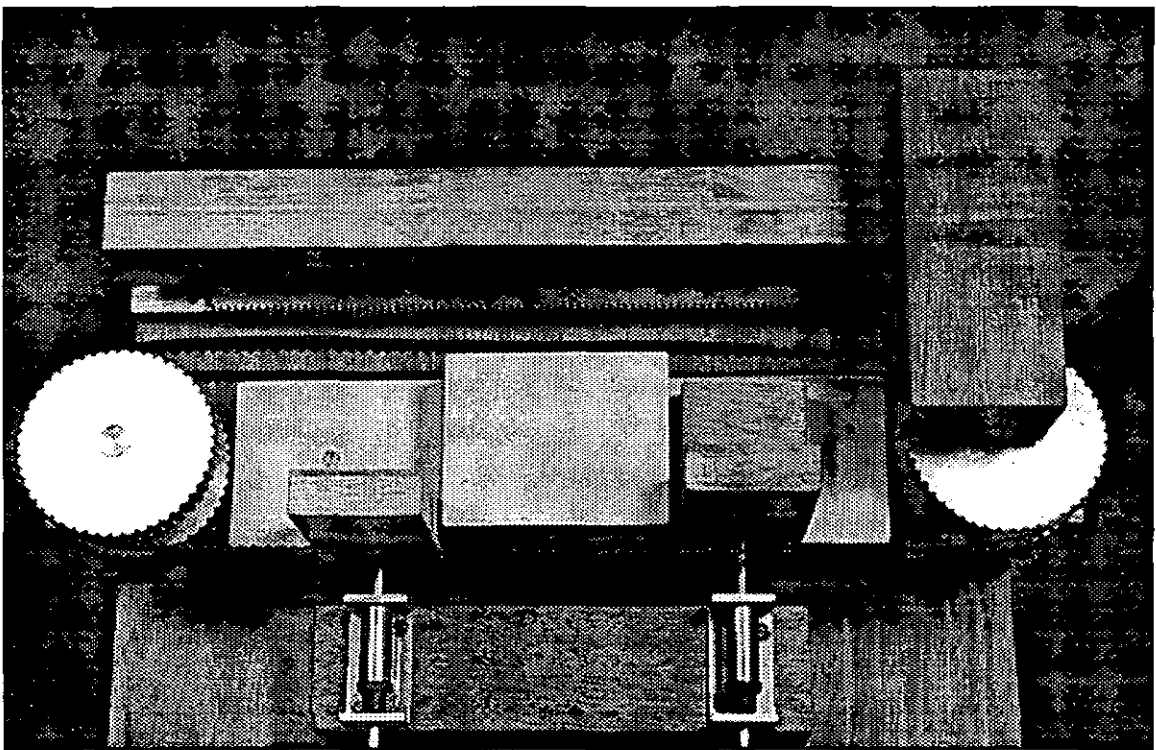

Figure 7.7: The model of the prototype matrix-on-belt approach.

could be used here as well.

There is a problem with this approach in that again the model has to change orientation between printing machines so a modification to the matrix-on-belt idea was adopted and a prototype model built to test out the theory (Figure 7.7). In this approach a rack is used to rotate the model about its perpendicular axis and a guiding mechanism to roll it into the horizontal plane.

7.2.6 Other modifications to the printing machine.

Another possible beneficial modification to the pad printing machine would be the incorporation of a cleaning mechanism for the pads. This could simply be a piece of sticky tape onto which the pads are pressed after every printing cycle. This would require the firmware in the printing machines RAM to be rewritten to facilitate this and an additional 'printing' position for the pads.

7.3 OTHER PRINTING TECHNOLOGIES.

Before finishing the discussion on improvements to pad printing it is important to mention two other technologies, ink jet and transfers.

7.3.1 Ink Jet Printing.

A demand for a fast, computer compatible printing method has produced a new technology, ink jet. The common principle that characterises all the various types of ink jet printing is the projection of a small, electrically charged ink droplet on to the surface to be printed. The process is controlled on a drop-by-drop basis in the order of 100,000 droplets per second. Each droplet is deflected by passing it through an electric field in a similar manner to that employed in a CRT. Unwanted droplets are deflected into a gutter and pumped back into the main system to be used again.

Recent advances in ink jet now incorporate arrays of nozzles so that the restriction on printing using a single nozzle has been removed allowing a greater selection in the size and style of font that can be used, also graphics can now be produced with much better definition. Unfortunately the technology still exhibits a number of disadvantages which make it unsuitable for fine decoration. These are:

- because the printing is applied via a finite array of holes, it is essentially a binary process. Therefore, on the surface being printed each dot is either there or not there which has the drawback that lines or edges which are not parallel or perpendicular

to the direction of printing have a jagged appearance.

- only a limited range of colours are available. Shades of colour can be obtained by printing dots of one colour amongst the dots of another, however, this has the appearance of a pointillist painting.

Trials have been conducted with one ink jet manufacturer for this project and the result, although reasonable, did not approach the quality of pad printing for the reasons mentioned above. Hornby Hobbies recognise, that in the short term at least, the only place for ink jet is in large area spray (Chapter 1.2.1).

7.3.2 Transfer printing.

This may be thought of as a retrograde step for Hornby Hobbies to be considering transfers having replaced them in 1977 with Tampo Printing. However, there are now a number of different transfer printing technologies in the market place. A recently announced waterslide process sounds very interesting and the author is attempting to find out full details of the process. Surface mount application techniques allied with UV curable transfers is another possibility.

Both of the above techniques, ink jet and transfer, are the subject of short term (1 year) feasibility studies into applying them to scale model decoration.

7.4 MECHATRONIC TOOL CHANGER.

The driving force behind the development of the mechatronic tool changer was the

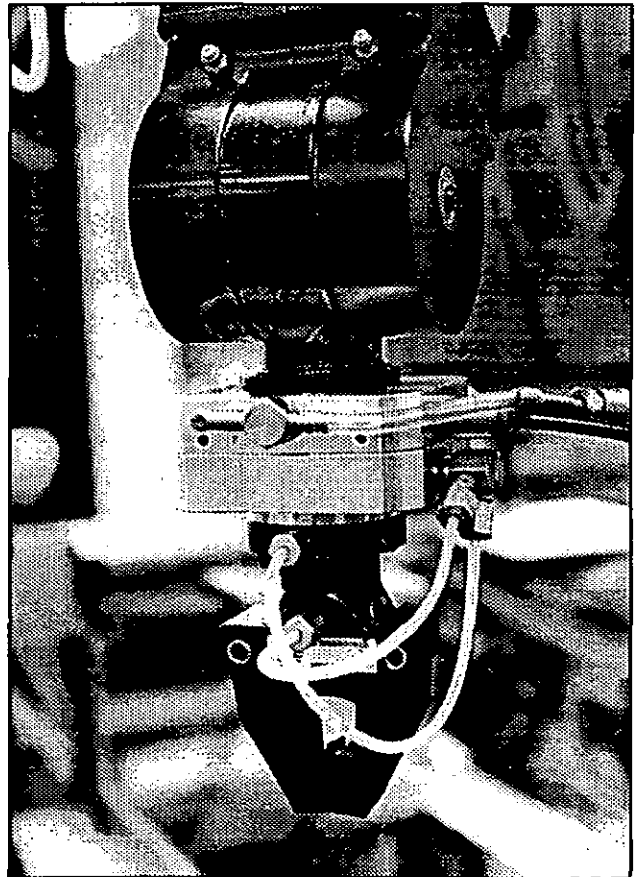

Figure 7.8: The Mechatronic tool changer.

difficulties experienced with the present tool changer (Chapter 3.2.4.1). In the beginning the intention was to develop a tool changer that did not require the PUMA robot to return to a tool rack for every tool change. Only with this condition satisfied could the original matrix-on-belt approach be considered as a viable working proposition. After the first test though, it became apparent that it could be applied to any robotic situation that required a tool changer. It weighs 0.5 Kilograms and can lift 22 Kilograms. A patent is now being sought for it.

7.4.1 The locking and unlocking principle.

The tool changer has active pneumatic locking based on the Venturi principle and active un-

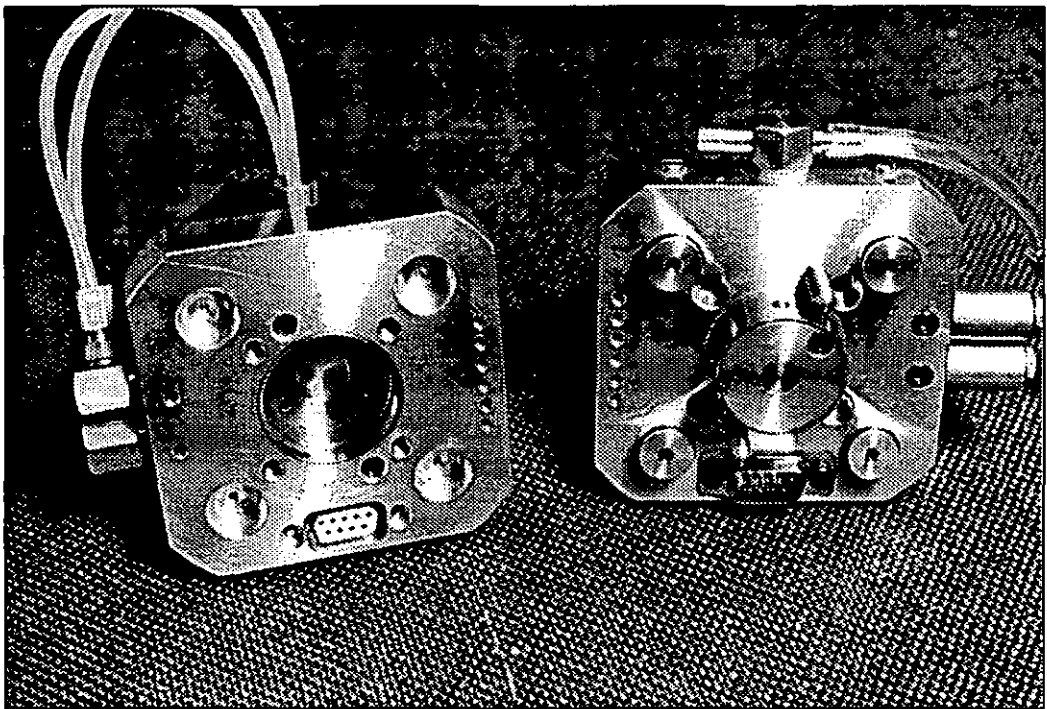

Figure 7.9: The passive and active locking mechanisms of the mechatronic tool changer.

locking based upon positive air pressure. Passive mechanical locking is also built into the unit in case of air failure. This is able to withstand a continuous load of 16 Kilograms.

A single venturi device with four outlets with 'O' ring seals is built into the robot adaptor (Figure 7.9), these outlets fit into four cavities in the tool adaptor. To lock the mechanism the exhaust of the venturi is left open and a vacuum is generated in the cavities pulling the two parts together. To unlock, the exhaust is blocked so that a positive pressure is generated and the two parts are blown apart.

7.4.2 *Pneumatic and electrical ports.*

The prototype tool changer is provided with two pneumatic ports, which are not self-sealing, and six opto-electrical connections which are less susceptible to wear and dirt and electrical interference than the more usual mechanical connections. Power is transferred between the two parts of the tool changer by a small jack plug.

7.5 SINGLE AXIS FORCE - ACCELERATION ADAPTOR.

Because it was felt that some of the techniques learnt and applied in the decoration cell could equally be applied to other applications, a start has been made on looking at possible methods of automatic assembly of model car chassis'. The first area of interest is the assembly, from the component parts, of rear axles and their fitment into the chassis. One particular problem is the actual fitment of the assembled axle into the chas-

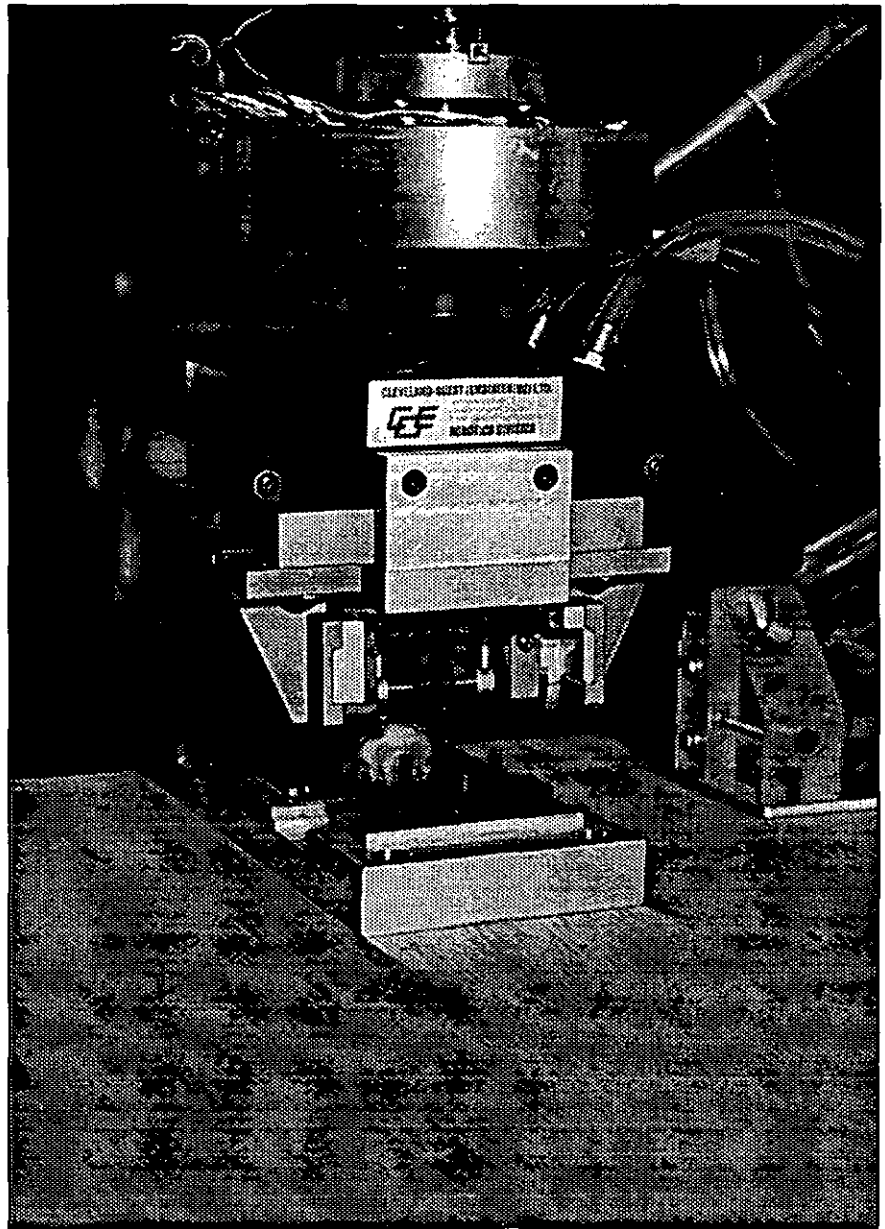

Figure 7.10: The force / acceleration adaptor undergoing trials.

sis. This necessitates a 'snap' fit as the axle bearings are pushed into the chassis, Figure 7.10.

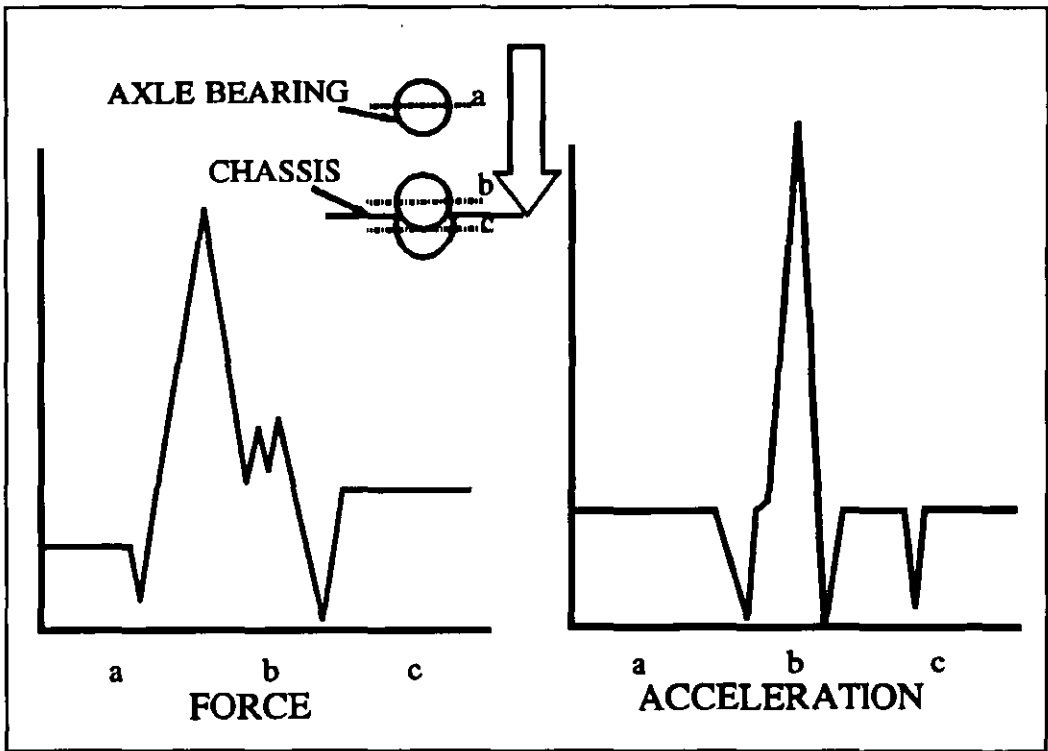

Figure 7.11: The graphs of force and acceleration for the assembly of an axle into a chassis.

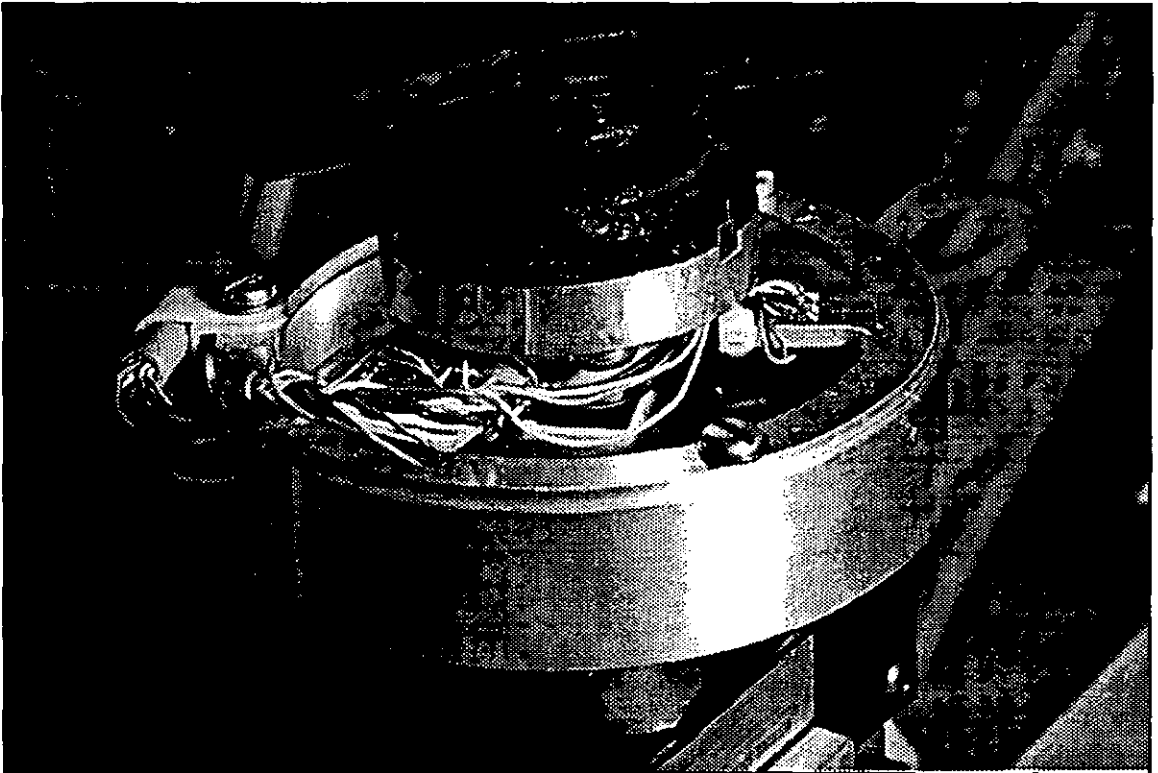

Figure 7.12: Single axis force-acceleration adaptor.

To measure this using an ordinary load cell would not allow the operator, or robot, to know if it was being pushed home correctly or it was jamming. But if you measure acceleration at the same time then a much more accurate picture of the assembly operation is provided, Figure 7.11.

A simple attachment for the PUMA robot (Figure 7.12) has been designed and is currently undergoing trials to test its accuracy and repeatability as well as its suitability for single axis force-acceleration measurement.

7.6 BALANCED CONFIGURATION DESIGN

The natural extension to the decoration project is assembly. The particular problems that Hornby Hobbies experience are in the handling of flexible and unstructured objects, mainly in the form of the wiring looms used in the cars and trains. The other components are of standard type but of varying dimensions.

Taking the rear axle assembly as an example of the type of problem experienced with assembly. There are 6 different axle lengths, 10 wheel types, 5 different types of tyre and 15 different axle bearing centres. With this number of combinations the possibility of producing an item for rework or scrap is very high indeed.

It would be impracticable to consider producing a separate item of sensorless automation for each axle combination. Likewise an universal axle assembly machine would be prohibitively expensive. As a compromise it is felt that concurrent engineering techniques should be applied from the design stage so that a sensible balance is achieved between the two.

This approach is referred to as Balanced Configuration Design and an experimental unit has been constructed to test out these principles (Figure 7.13). It is not totally sensorless nor is it over endowed with sensory feedback. The author feels that if the force/acceleration sensor described in section 7.6 is used in conjunction with an unit of this type and the assembly/manufacturing constraints considered at the design stage then this will lead to a reduction in assembly time and an improvement in product quality.

This idea is the basis of a further research proposal to the S.E.R.C.

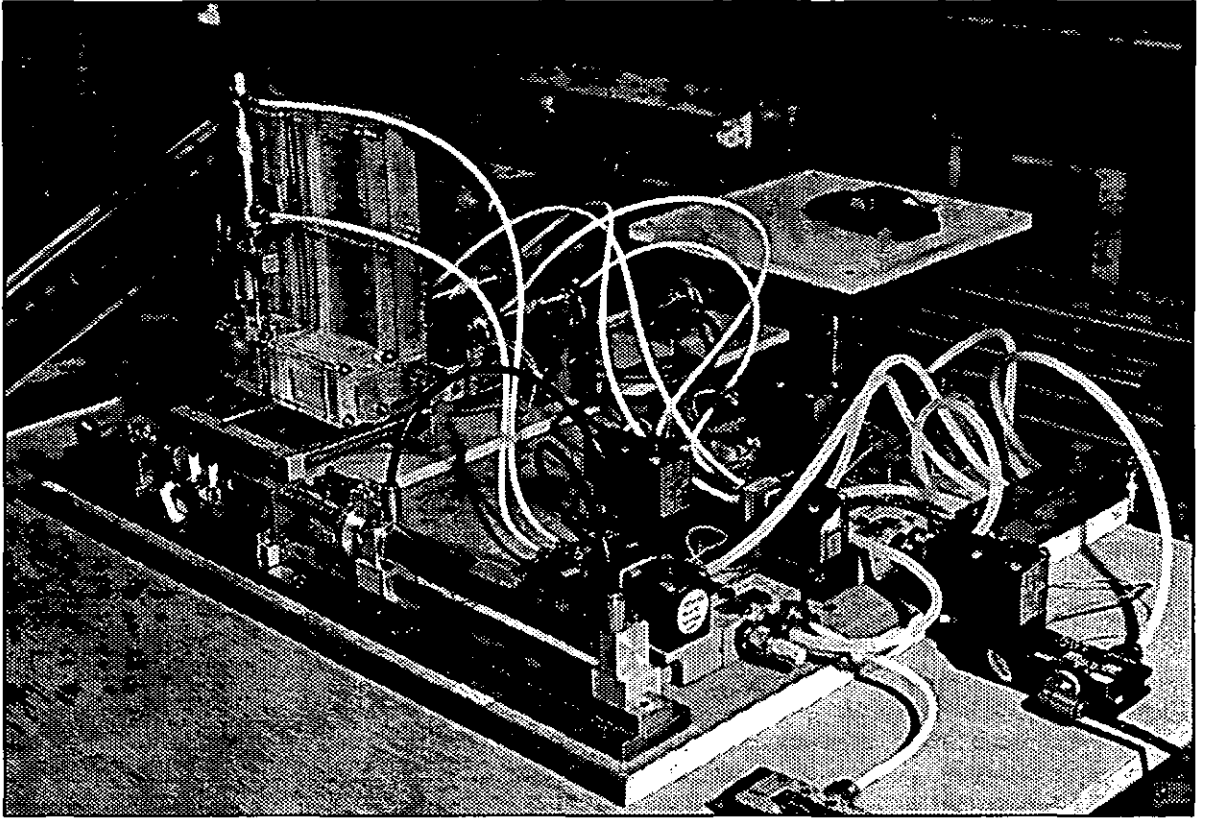

Figure 7.13: Balanced Configuration Design experimental unit.

7.7 ARTIFICIAL INTELLIGENCE APPLICATIONS.

It was found that some Artificial Intelligence tools could be applied to the robotic decoration process to improve its performance in certain areas {Trabasso et al,1990a}. For an introduction to Artificial Intelligence applications to Robotics refer to Staugaard Jr. {1987}. Three such areas are:

- start up of the cell
- assessment of the training process
- recovery strategies

All the applications are to be implemented using the expert system shell SAVOIR as this is readily available within the Department of Mechanical Engineering.

7.7.1 Start up of the Decoration Cell.

This tool consists of a programme to aid the operator carry out the start up procedure detailed above. The more automated this operation becomes the easier it will be for the operator, especially untrained ones. The programme takes the operator through the start up procedure of the cell step by step, asks questions and displays the operational status of the cell based on the answers given. It also provides explanatory notes whenever requested. Figure 7.14 shows a computer screen with the corresponding graphical output when the reply is given.

The next stage of this application will be to have sensors linked into the variables in the cell so that the responses currently given by the operator will be replaced by readings from the sensors.

7.7.2 Assessment of the training process.

The success of the operation of the identification station relies mainly on the training and classification processes performed by the operator during new model changeover. It can easily be shown that a poor training process will lead to poor results in the classification routine. Unfortunately the result of the training process can be different when performed by different operators since some of the decisions are left to the operator's judgement: the definition of the threshold levels to transform a grey image into a binary image is one example. Based only on visual inspection, the operator has to

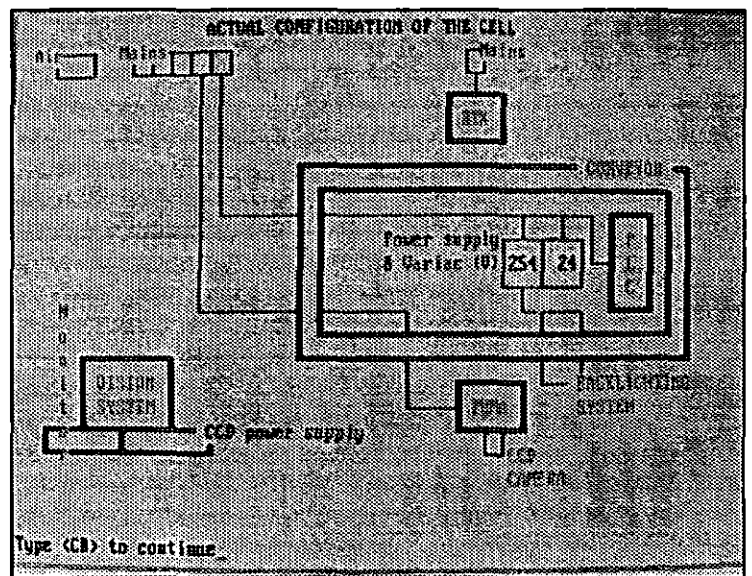
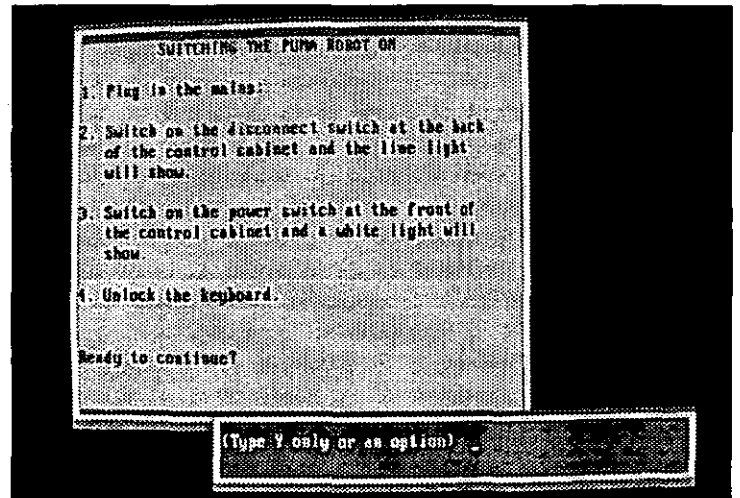

Figure 7.14: Example of a consultation session by the operator during the start up of the decoration cell.

decide whether the binary image is good enough to represent the object in view. One approach which is now emerging for tackling this problem is to simulate the data of the training process on a CAD workstation and then load these synthetic images into the vision system database as described by Rauber {1989}. There are a number of problems with this method such as:

- the simulation of the lighting conditions
- unexpected reflections and shadows
- the small number of positions of the object.

This has led to another approach. The training process is left as it is with the same degree of subjectivity and the knowledge about the training process is stored in an expert system. This is then used to 'judge' the result of the training process based on information gathered from the classification process.

The expert system asks the operator to place the model in the field of view of the vision system and run the classification routines a number of times. After each run the operator inputs the values of the orientation angle and centre of boundary of the object into the expert system. This information is then used by the expert system to generate the value to be tested in the function MEMBER². Based on the membership test the expert system may ask the operator to repeat the training process, giving a list of parameters that can be changed in order to improve the result.

7.7.3 Recovery strategies.

The recovery actions are presently built into the various programmes that control the component parts of the decoration cell. For instance, the recovery action of the loading station is part of the PLC programme.

² MEMBER is a fuzzy set function within the SAVOIR shell. It returns the probability that a given value is in a particular range. If the value is outside pre-set wide bounds MEMBER returns 0.0, if it is within a narrow bound MEMBER returns 1.0. For values in between MEMBER will return a probability between 0.0 and 1.0 scaled by linear interpolation.

The ideal scenario, and one which the author is working towards, is to have all the deviation sensors linked into a single programme. An ideal programme is an expert system shell which has the structure for keeping the recovery actions through production rules. A particular input from the sensors would trigger a corresponding recovery action.

Even though parts of these programmes are being built and tested they are not yet implemented in the decoration cell.

7.8 APPRIMA - THE NEXT GENERATION OF PAD PRINTING MACHINE.

The reader may well wonder why the researcher has continued to bring forward new ideas for modifications to pad printing machines when it is becoming clear that there are still many other areas to explore. Referring back to Chapter 1.3 he will see that one of the constraints imposed on the project was that it should utilise the existing tampo print machines. For the purpose of this chapter that constraint does not exist and so a completely fresh look at pad printing has been possible.

A list of desirable attributes were drawn up and these were as follows:

The new printing machine;

- must be capable of rapid changeover between models,
- must use a closed ink system,
- must be capable of multi-colour printing,
- must be able to decorate a multi-sided article,
- must operate at around the current pad printing speed i.e. in the order of one cycle per every three seconds,

- should have built in quality control,
- should be 'intelligent' in that it can sense when things are going wrong and be self correcting,
- should be capable of printing different sized decorations without outside assistance i.e. it must have the capability of automatic pad change,
- should have the ability for automatic pad cleaning,
- must be easy to operate and set up,
- must be competitive on price.

These ideal features were compared with the present designs of printing machines (Table 7.1) to see where the differences were between what is available and what would be desirable.

Table 7.1: The comparison of the features incorporated in the different designs of pad printing machine.

Present machine	'Advanced' machine	APPRIMA
Fixed cliché	Fixed Cliché	Adjustable cliché
Open ink reservoir	Closed ink tubs	Closed ink cartridges
High precision	High precision	Medum precision
1 degree of freedom	2 degree of freedom	1 degree of freedom, adjustable
Mechanical elements	Mechanical elements + encoders	Sensory feedback via vision
Manual loading/unloading	Manual loading/unloading	Integrated mechanical handling
Human inspection	Human inspection	Computer based vision
Manual switching	Stored sequence	Fully programmable with learning
£5K	£120K	£50K

Many ideas were explored to encompass all of the above desirable attributes, also visits to trade shows to see how the current printing machine manufacturers were approaching the problem. A patent search was also undertaken to establish which areas are not covered by patents and how the present designs are protected.

None of the present designs of pad printing machine incorporate quality control or self correction capability, and there is only rudimentary handling built in for objects. In fact, apart from simple one sided decoration of an object on a conveyor system, all still require manual loading and unloading. The only large pad printing machine on the market to offer multi-colour printing uses large sealed ink units which do not allow for printing large areas in one pass, the decoration has to be built up and without automatic feedback there is no way that the registration of the printing can be controlled.

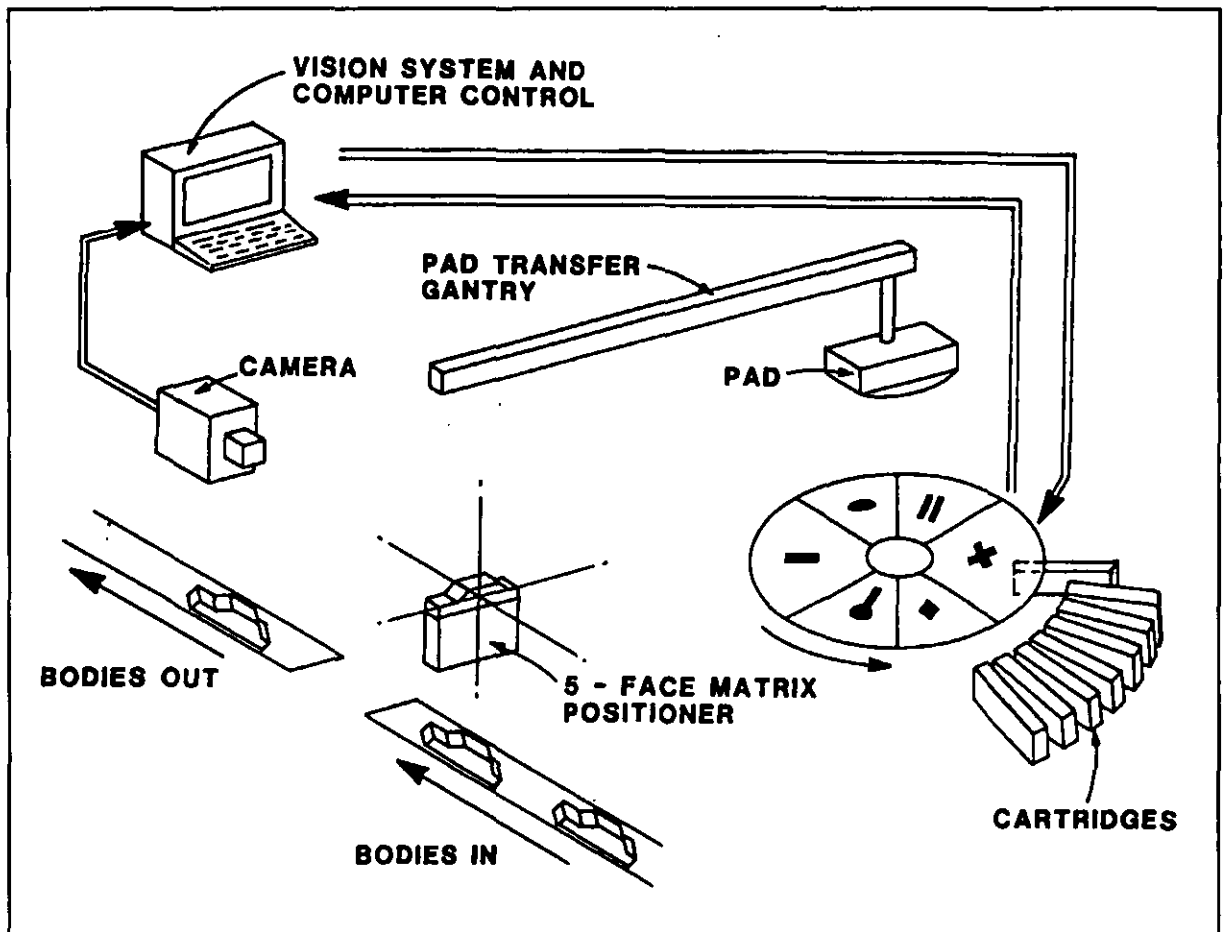

Figure 7.15: A schematic of APPRIMA.

Figure 7.15 shows a schematic of the APPRIMA³ printing machine which is the subject of a current research proposal to the DTI LINK High Speed Machinery Initiative. The outline Mechatronic design draws upon the knowledge gained from the present research project to incorporate all of the above features plus some novel inking and handling mechanisms which, along with the incorporation of on-line quality control and self calibration/regulation, will form the basis of the research content of the project.

To give some idea of the perceived success of this project, many of the ideas mentioned above for tool changing, force sensing and pad printing are being used as start up projects for a completely new venture being undertaken by the Department of Mechanical Engineering at Loughborough University of Technology. This is MEDUEI⁴, which is intended as a means of taking 'good' ideas from research projects and producing working marketable prototypes so that they can then be exploited commercially.

³ Advanced Pad PRInting MACHine for Just-in-Time Production.

⁴ MEchatronics Design Unit for the Exploitation of Invention.

CHAPTER 8:
CONCLUSION

8.1 SUMMARY.

The results of this work can be looked at in two different ways: the contribution to scale model decorating and hence pad printing and the contribution to Mechatronics.

8.2 CONTRIBUTION TO SCALE MODEL DECORATION AND PAD PRINTING.

The design requirements of the decoration cell stated in Chapter 1.3 can be summarised as follows:

Design a decoration cell which is capable of fully decorating any bodyshell manufactured by Hornby Hobbies Limited at a production rate of 60 bodyshells per hour.

A detailed analysis of the cell flexibility was presented in Chapter 3. This pointed out that the use of open ink well pad printing machines was the greatest constraint on the flexibility of the proof-of-concept cell. All but the decoration station can be quickly and easily reconfigured to execute a new decoration on a different bodyshell. No special jigs were required so that the bulk of the hardware in the cell remains unchanged after a changeover to a new product. The majority of the changes are in software.

It is believed that the flexibility requirement was met and that the adoption of closed ink systems, such as those described in Chapter 1.5.3, by Hornby Hobbies Limited, would make the flexibility of the decoration cell more realistic.

Another important requirement was the flow line approach to decorating the bodyshells. In this proposal the bodyshell is only removed from the matrix after it has been fully decorated. This is a major improvement on the current factory based method.

Undoubtedly the high quality of the decoration process was maintained through the concept of the peg-in-hole approach described in Chapter 7.2. Figure 8.1 shows an example of the one of the first mechatronically decorated bodyshells.

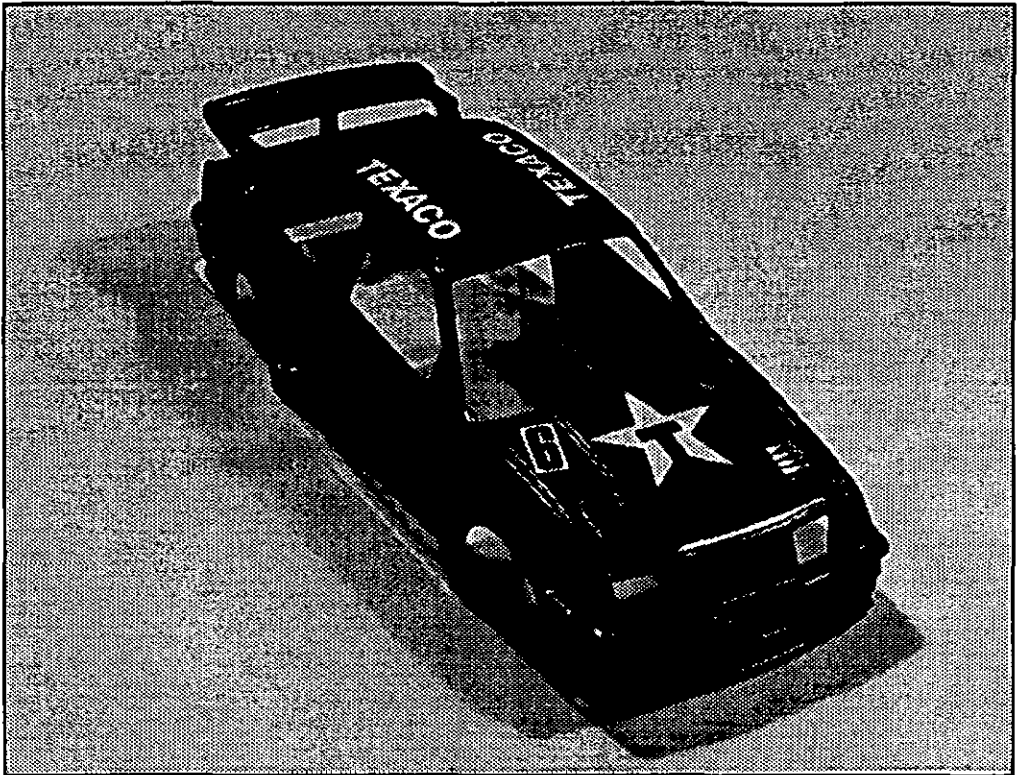

Figure 8.1: The first Mechatronically decorated bodyshell.

The trial was carried out using just a single colour painting the bonnet and roof in the manner described in this work. The roof logo should be red and not white. The poor quality of the decoration on this sample is probably due to one or more of the following reasons:

- lack of experience with the printing technique,
- 'dirty' bodyshell, which had been handled many times and was probably therefore greasy,
- poor cliché.

It was stated in Chapter 7.2.2 that some form of active restraining device would be required to prevent the bodyshell from falling from the matrix during movement by the PUMA robot. Because of the shape of the particular car used to prove the decoration cell this was not necessary, but for most of the other bodyshells this would have proved to be an essential requirement.

Another important contribution to the overall project was the incorporation of on-line quality control. It is now no longer subjective and inconsistent.

Obviously it is only possible to estimate the production rate for the proof-of-concept cell as only one printing machine was actually linked into it. However, this time could be dramatically improved by incorporating the ideas outlined in Chapter 7.2, which still maintain the peg-in-hole approach, but explore the full potential of the printing machines.

It is important to note that the decoration cell was designed in such a way that it could be incorporated into the factory environment. Refer to Figure 6.1. The injection moulding machines are at one end feeding plain bodysshells in and fully decorated palletised bodysshells, ready for assembly, are presented at the other. When the assembly operation is eventually fully automated this will be an important requirement, in that the position and orientation of the fully decorated bodysshells will be already known.

It is believed that the initial design requirements of the decoration process have been met. Obviously it is not intended that the proof-of-concept cell be simply moved from the laboratory to Hornby Hobbies Limited. However the author believes that much of the work presented here can be readily incorporated into an automated decoration process when Hornby Hobbies Limited choose this route.

8.3 CONTRIBUTION TO MECHATRONICS.

The essence of the work was highly practical: the final result producing one of the few fully working integrated demonstration cells of its type. Consequently it is not expected to have a major theoretical impact.

Some people claim that there is no need for another discipline such as Mechatronics, as it has been practised for years, often without the practitioners realising it or being conscious of the name. One expects, however, to find totally different results when the Mechatronics approach is used intentionally rather than by accident.

It is difficult to visualise the final configuration of the proof-of-concept cell as a whole if it had been designed by techniques other than the Mechatronics approach. However, it is not difficult to carry out this exercise with two examples of parts of the cell.

- 1) After facing the problems with the reflections when identifying the bodysells, the solution of using a jig or restraining device to locate the bodysells seemed to be the only viable solution even though it was at the expense of flexibility. Opposing this purely mechanical solution was the side-lighting system, which is an integrated electrical-mechanical solution, which overcame to problem and maintained the total flexibility of the cell.
- 2) The re-positioning device is another example in which a simple mechanical solution solved the problem of optical illusion error that could only be solved otherwise by a very complex software route.

These are only examples of cheap, simple and efficient solutions to the overall efficient running of the proof-of-concept cell whose conception was arrived at as a direct result of the Mechatronics approach to design. Thus it can be said that the decoration cell is a rather good example of a mechatronic product. The key element of Mechatronics, *integration*, can readily be seen when the cell is operating.

Mechatronics must be thought of as a technology that one has to be aware of in order to design low cost, simple and versatile products.

Having worked on this project, the author acknowledges that he has now acquired the Mechatronic way of looking at problems i.e. *How can he design this product so that he allocates the functional requirements between the mechanical, electronic and computing science environments?*

REFERENCES

FU, K.S., GONZALES, R.C., LEE, C.S.G. (1987). *Robotics: Control, Sensing, Vision and Intelligence*. McGraw-Hill, Singapore.

KAYE, G.W.C. (1973). *Tables of Physical and Chemical Constants*. pp 91, Van Nostrand Reinhold, New York, NY, USA.

JOYCE-LOEBL. (1985). *Image Analysis: Principles and Practise*. Gateshead, Newcastle-upon-Tyne, U.K.

JOYCE-LOEBL. (1987). *Magiscan: Pascal Programmers Guide*. Gateshead, Newcastle-upon-Tyne, U.K.

INTELLIGENT SYSTEMS INTERNATIONAL. (1987) *The Savoir Expert System Shell: Programmers Guide*. Surrey, UK.

MITSUBISHI ELECTRIC CO. (1987). *Melsec F1 Series Mitsubishi Programmable Controller: Programming Manual, High Function Version*, Tokyo, Japan.

RAUBER, T.W. (1989). *Generating Synthetic images Using PADL-2*. New University of Lisbon, Department of Robotics, Lisbon, Portugal. (Technical report GR RT-PS-10-89).

ROACH, S., (1989). *Design of an Automatic Tool Changer for the PUMA Robot*. Loughborough University of Technology, Department of Mechanical Engineering, Loughborough, U.K. (Final year project report).

RUOCCO, S.R. (1987). *Robot Sensors and Transducers*. Open University Press, Milton Keynes, U.K.

SEYER, M.D. (1984). *Rs-232 Made Easy: Connecting Computers, Printers, Terminals and Modems*. Prentice-Hall Inc., NJ. USA.

SHINGO, S. (1986). *Mechanical Engineering Design*. McGraw-Hill, New York, NY. USA.

STAUGAARD Jr, A. (1987). *Robotics and AI: an Introduction to Applied Machine Intelligence*. Prentice-Hall Inc., Eaglewood Cliffs, NJ. USA.

TRABASSO, L.G., HEWIT, J.R., SLADE, A.P. (1989). *A Vision Assisted Robotic Decoration of Scale Models*. Proceedings of the 2nd International Conference on Robotics, Dubrovnik, Yugoslavia, 1989.

TRABASSO, L.G., HEWIT, J.R., SLADE, A.P. (1990a). *Artificial intelligence techniques Applied to the Decoration of Scale Models*. Proceedings of the IMechE Conference on Mechatronics: Designing Intelligent Machines, Cambridge, U.K. pp 165-170, 1990.

TRABASSO, L.G., HEWIT, J.R., SLADE, A.P. (1990b). *Decorating Scale Models the Robotic Way*. Proceedings of the 11th International Conference on Assembly Automation, Dearborn, Detroit MI, pp831:1-12, 1990.

TRABASSO, L.G., HEWIT, J.R., SLADE, A.P. (1990c). *A Vision Assisted Robotic Cell for Scale Model Decoration*. Proceedings of the 28th International Matador Conference, Manchester, U.K. pp 35-40, 1990.

TRABASSO, L.G., HEWIT, J.R., SLADE, A.P. (1990d). *Robotics applied in the Decoration of Scale Models*. Proceedings of the 8th CISM - IFToMM 'Ro.Man.sy' Conference, Cracow, Poland, 1990.

TRABASSO, L.G., HEWIT, J.R., SLADE, A.P. (1991a). *The Education of Mechatronic Engineers*. Proceedings of the International Conference on Computer Aided Engineering Education. Prague Czechoslovakia, 1991.

TRABASSO, L.G., HEWIT, J.R., SLADE, A.P. (1991b). *Intelligent Decoration of Scale Models*. Proceedings of the 4th World Conference on Robotics Research. Pittsburgh, PE. 1991.

TRABASSO, L.G., HEWIT, J.R., SLADE, A.P. (1991c). *Integrating Vision and Robotics to Assist With Scale Model Decoration*. Proceedings of the IMechE Conference - Eurotech Direct '91, Birmingham, UK. paper number C415/052, 1991.

TRABASSO, L.G., HEWIT, J.R., SLADE, A.P. (1991d). *Manufacture of Scale Models With a New Control Strategy*. Proceedings of the IMACS - IFAC Symposium on Modelling and

Control of Technological Systems. Lille, France, Vol 1, pp 621-626, 1991.

TRABASSO, L.G., HEWIT, J.R., SLADE, A.P. (1991e). *Printing Scale Models Using Mechatronic Techniques*. Mechatronics. Vol 1 number 1, pp 95-104, 1991.

TRABASSO, L.G., HEWIT, J.R., SLADE, A.P. (1991f). *Vision Assisted Robotics in the Decoration and Assembly of Scale Models*. Proceedings of the Eurovision - Imacs Conference, Corfu, Greece. 1991

TRABASSO, L.G, and ZIELINSKI, C. (1990). *Semi-Automatic Calibration Procedure for the Vision-Robot Interface Applied to Scale Model Decoration*. Robotica. (1990).

WALDON, S. and MYSTEL, A. (1988). *Multiresolutional Representation of Spatial Knowledge in Intelligent Control*. Artificial Intelligence in Engineering: Robotics and Processes. Computational Mechanics Publications, Southampton, UK.

