

Developing Novel Explanatory Models For Electronics Education

Sarah Pulé, Department of Mathematics, Science and Technical Education,
University of Malta

Dr John McCardle, Department of Design and Technology, Loughborough University, UK

Abstract

This paper explores how representations of technological concepts may be designed to help students with visual learning styles achieve successful comprehension in the field of electronics. The work accepts a wide definition of what is understood by the visualisation of a model in that it can take different external forms, but also include an internal representation in a person's mind. We are of the opinion that to acquire scientific or technological knowledge there is a requirement for abstract models to exhibit particular features that complement the nature of their fields, and that their effectiveness is dependent on the context in question. This work reports on the development of experimental materials which are novel teaching aids in the context of electronics education. It proposes design principles based on congruent, schematised, symmetrical spatial metaphors of circuits incorporating interactivity by the use of gesture, scaffolding, learning by topological, analogical and conceptual resemblances. We conclude that qualitative methods may be employed with a significant measure of success even for a field such as electronics that is often considered to be difficult due to the necessity of abstract explanations.

Key words

electronics, education, visualisation, models, abstraction, external representations

General Problems Associated with Teaching Electronics

The study of electronics, as an engineering discipline, is fraught with learning pitfalls through potential misunderstandings. Unlike other engineering technologies such as structural mechanics, it offers fewer opportunities to gain a 'feel' for the subject. It offers fewer visual cues and there is no sense of naïve physics with respect to quantities. In the statics and dynamics of mechanics for example, an awareness of the nature and strength of materials, life experience of the effects of gravity, a general direct physical feeling of mass and force, a sense of speed etc provide us with an inherent scaffold to support access to further study. In the quantum world of electricity we are, in effect, blind to any phenomena and consequently there has been a tradition of access purely through abstract theory and the application of number.

In electronics the use of circuit schematics accompanied by graphs and mathematical functions are common-place,

but even the most simple of circuits can cause problems in offering explanations and learning about function. Demonstrating an understanding of a subject invariably involves some form of verbal articulation as explanation, for both knowledge transfer and assessment purposes. The abstract nature of the subject demands clear articulation of explanations, but often requires complex metaphorical and consequently abstract language to do so. This is a paradox that hinders the learning of many concepts in electronics.

There are a number of very good electronic circuit simulations packages commercially available that have assisted in learning about electronics. However, in the main these packages act primarily as visualisers, and whilst this is a vital component of human perception, it ignores other important senses that are often required for effective understanding and articulation of explanations. This paper describes on-going research into developing new approaches to electronics education that is appealing to specific learning styles and is consequently more instinctive.

An example of misunderstanding a circuit schematic.

The following image and description were taken from a written report that was presented by a D&T student. The written report was accompanied by a perfectly functional electronics hardware project. The illustration of the circuit diagram as shown in Figure 1 was prepared by the student, and it is assumed that this reflects the mental model with which this individual has chosen to describe the function of a pull-up resistor.

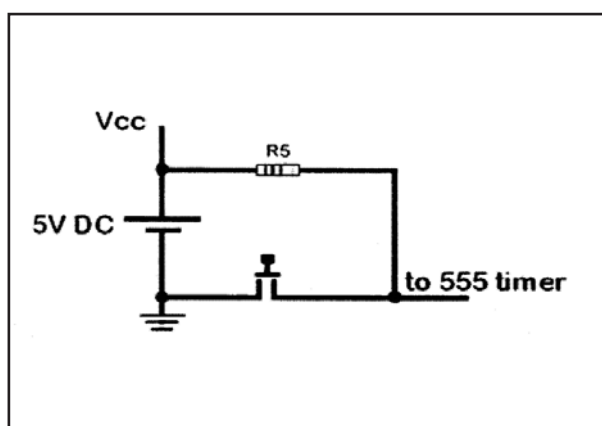

Figure 1. 'Pull-up' Resistor Circuit as drawn by student

Developing Novel Explanatory Models For Electronics Education

The student's explanation was:

'When the push switch is open the only way which the current could flow through is the resistor. When the switch is closed the current prefers the easiest way instead of the resistor. A helpful analogy is to describe the resistor as an off road path and the closed switch as a very smooth path. As the electrons are lazy they prefer the smoothest path.'

This statement indicates that the student did not understand how a pull-up resistor works. It may be the case that the student's misconception originated from the way he chose to depict the circuit. The schematic in Figure 1 can give the impression that the resistor and the switch are in parallel, when in fact they are not, if considered with respect to the voltage source. The way he chose to draw this circuit may have led him to think of currents rather than voltage levels and therefore to an erroneous description and misconception of the dynamics of a pull-up resistor.

When teaching electronics examples such as this are common and illustrate the difficulties students encounter. Consequently, the long term aims of this study aims to address the following research questions:

1. Does the topology of a circuit schematic influence the conceptual understanding of its electronic working principle?
2. How can the dynamic abstract concept of an electronic circuit be visualised qualitatively by using its circuit schematic as an external representation?
3. What are the design principles involved to achieve this?
4. Will principles correlate to students' learning styles?
5. What are the effects of such qualitative representations on students' perspectives of electronic concepts? And what prior knowledge matters?

Of course, this paper cannot address all these, but the current research study alludes to a set of complex criteria that if well considered can result in effective design of interactive learning resources.

Models as Information

Baynes (2009), provided a pragmatic way for describing the nature of different kinds of models in the now familiar modes of iconic, symbolic and analogue, and combinations thereof, but Gilbert (2007), considers that one or more categories are employed:

1. Concrete (or material mode): 3D and made of resistant materials.
2. Verbal mode: Spoken or written.
3. Symbolic: consisting of representation of abstractions, like chemical symbols, formulas and mathematical

expressions so that these may be treated as objects.

4. Visual: including graphs, diagrams, animations, 2D representations, 3D computer images.
5. Gestural: making use of the movement of the body or its parts.

When models and simulations are dynamic, they provide a visual explanation of causal mechanisms and processes underlying phenomena, especially when these are not directly observable because of their scale.

Models of any shape or form may play a very important part in cognitive learning. This is highlighted by the principle of distributed cognition proposed by Zhang and Norman, (1994), which suggests that a cognitive task is distributed into a set of internal and external representations which together characterise the abstract nature of the task. They claim that it is therefore the interwoven processes of internal and external information that generate much of a person's intelligent behaviour. Zhang and Norman also consider that a problem space is constructed by a set of rules, and given that these rules do not vary, the abstract problem space is fixed. This abstract, fixed space may nevertheless be distributed across internal and external representations in different ways, and each distribution may have diverse effects on problem solving behaviour, even if the fixed, formal structures of the problem do not change. Thus, and especially so in a scientific or technological context, models may provide a bridge between theory and reality in distinctive ways. They can act as simplified depictions of reality as observed, or else, they can be idealisations of the world as imagined, based on the abstractions of theory.

Visualisation of Models

Within the context of engineering education, Kolari and Savander-Ranne (2004) view visualisation as a means of forming a picture, a model or scheme of something in the mind. Rapp (2007, p52), accepts visualisation as, 'a novel visual presentation of data'. Visualisation, is used to help the students form mental visual images and to make visual interpretations of what concepts and processes mean or to clarify abstractions. In this way, visualisations aid learning through the perception and processing of information.

According to Gobert (2007), in the fields of psychology and education, visualisation is commonly characterised by the following three categories:

1. *external*; that take the form of graphics, diagrams, models and simulations. These forms are all semantically rich because they involve complex, domain-specific symbol systems whose comprehension is usually involved.

Developing Novel Explanatory Models For Electronics Education

2. *internal*; mental models that take place in the mind.
3. *as a type of spatial skill*; the ability to re-arrange and transform images and spatial patterns to form new information.

Reisberg (1997), considers it important to distinguish between the following types of visualisations:

1. Visual perception – the image of an object achieved when and as it is seen.
2. Visual imagery – the mental production of an image of an object in its absence.
3. Spatial imagery – the production of a mental representation of an object by tactile means.

Gilbert (op.cit) maintains that visual perception and visual imagery involve similar mental processes and are therefore mutually supportive. Visual perception is considered selective and this selectivity is considered responsible in part for the qualitative differences in any subsequently produced visual image. Consequently, since visual images may be a filtered version of visual perceptions, the products of either may differ substantially.

Clearly, visualisations used as explanations are a fundamental element of communication with each type of visual representation having a purpose. Problem solving may certainly be aided greatly simply by translating one particular representation into another (Larkin and Simon, 1987).

External Representations

According to Zhang (1997), *external representations* are purely external models in that they take the form of physical symbols, objects or dimensions (for example written symbols, dimensions of a graph, beads on an abacus), or external rules, constraints or relations embedded in physical configurations (for example visual and spatial layout of diagrams, spatial relations of written digits). However, Zhang emphasises that external representations are not merely inputs and stimuli to the internal mind. The most obvious property of external representations is that they can serve as memory aids but, they can also extend working memory, form permanent archives and allow memory to be shared. Indeed Zhang claims that for many tasks, external representations are so intrinsic to the task itself that without them the task may completely change in nature or even cease to exist. In certain cases, without a change of representational form some portion or structure of the task space may never be discovered.

Zhang and Norman have identified several properties of effective external representations:

'... they provide information that can be directly perceived and used without being interpreted and formulated explicitly. ... they can anchor cognitive behaviour. That is, the physical structures in external representations constrain the range of possible cognitive actions in the sense that some actions are allowed and others prohibited. ... they change the nature of tasks: tasks with and without external representations are completely different tasks from a task performer's point of view, even if the abstract structures of the tasks are the same.'

(Zhang & Norman 1994, p184)

There is evidence to suggest that the more rules that are externalised, the easier problem solving becomes. When investigating personal performance in problem solving, Zhang and Norman (ibid.) postulate that one reason for this phenomenon is due to the fact that external rules can be checked by perceptual inspection, while internal rules must be checked mentally. The mental processing demands more resources of working memory, which possibly interferes with other critical processes essential for problem solving such as planning.

Designing Effective Visualisations as Representations

Whether a representation is effective depends on what knowledge of the subject in question is available for searching the data, for recognising relevant information and for drawing inferences from that information (Larkin and Simon, 1987). Larkin and Simon (ibid.) argue that one would be unable to recognise knowledge that is relevant to a situation and retrieve it from long-term memory if the situation is not presented in a form matching existing knowledge. In the context of physics, for example, they claim that if students lack knowledge for making physics inferences from diagrams, they may not only fail to appreciate the value of diagrams, but will find them largely useless. Gobert (2007) points out that students need supports to guide their search processes for acquiring rich spatial, dynamic, causal and temporal information from visual representations. Visual representations that are designed to make perceptual cues more salient would provide rich ways of developing students' learning and inference-making processes.

In the absence of prior knowledge, scaffolding in order to present information gradually is usually found to be beneficial for students. Gobert (2007) proposes the following features of a scaffolding framework that may specifically help to assist model based reasoning:

1. *Representational assistance*: This type of scaffold aims to guide student's understanding of the representations,

Developing Novel Explanatory Models For Electronics Education

- or domain-specific conventions, and to support students in using multiple representations.
2. *Model Pieces Acquisition*: Focuses students' attention on the perceptual features of the representations and supports knowledge acquisition about the spatial, causal, functional, temporal aspects of the phenomenon.
 3. *Model Pieces Integration*: Helps students combine model components in order to come to a deeper understanding of how they work together as a causal system.
 4. *Model Based Reasoning*: Supports students' reasoning with models – inference-making, prediction, explanation.
 5. *Reconstruct, Reify and Reflect*: Supports students in referring back to what they have learnt, reinforce it and move on to a deeper understanding.

Tversky (2007) also subscribes to the notion of scaffolding by maintaining that good explanations place things in context and capitalise on what the audience already knows. Thus, effective visualisations take into account human perceptual and cognitive capacities and draw on an individual's experience in making spatial comparisons and inferences. Combining the scaffolding of concepts with interactivity further enhances engagement with a learning task. When students can directly influence the course of their own learning, say by changing the pace or topic of a lesson, or by manipulating characteristics that personalise material in meaningful ways, they would effectively be building their comprehension with relevance to their own interests and prior knowledge (Rapp, 2007). Therefore, effective representations should allow the learner to quickly obtain a sense of overall topology of the network of concepts and some means to locate where, in the structure, any particular concept belongs (Cheng, 1999).

The prevalence of spatial metaphors in language and gesture suggests that mapping abstract relations onto spatial ones is natural and spontaneous (Tversky, 2007). Some mechanisms for perceiving and reasoning about the spatial world are therefore likely to be used for reasoning about other domains (Stenning and Oberlander, 1995). Tversky, (op.cit) also observed that certain directions were often loaded, for example the vertical direction being dominant and thus an upwards gesture is used to convey 'better', 'more', or 'stronger'. Tversky is also convinced that gestures reflect spatial thinking since 'good things get thumbs up while bad ones get thumbs down'. However, there are a number of cultural issues where gestural metaphors may not be universal (see Lakoff and Johnson, 1980).

Generically, Alibali (2005), identifies two classes of gestures, namely, representational gestures and beat gestures. Representational gestures are those that convey meaningful content by virtue of the shape, placement or motion trajectory of the hands, for example, tracing a trajectory in the air. Beat gestures are simple, rhythmic gestures that do not depict how content is related to speech.

Gestures promote reasoning only where the properties of the problem are based on spatial data. Whether spatial strategies are optimal or not depends on the specific problem situation. For gear problems, for instance, Alibali (ibid.) suggests that spatial strategies may not be optimal but are often successful, maybe because prohibiting subjects from gesturing was found to decrease their focus on information that involved action or movement. The use of gestures was highest among individuals who had a combination of high spatial skill and low verbal skill and suggests that when spatial skills surpass verbal skills, people may rely on gesture to communicate spatial representations. It may also be the case that gesture helps them translate their spatial knowledge into verbal form. Thus, by gesturing, speakers gain a fuller appreciation of their intended meaning and are better able to express that meaning in the linear symbolic system of language (Hostetter et al., 2007).

The perception of symmetry is another feature that appears to influence problem solving behaviour. In experiments conducted by Zhang (1997), subjects who perceived spatial symmetry, found that problems became easier to tackle. This may occur since the perception of symmetry reduces the number of alternatives that have to be thought of before a consistent strategy is found to solve a problem. Highlighting a critical component on a diagram also seems to effect the number of correct solutions that problem solvers may achieve (Grant and Spivey, 2003). Environmentally controlled perceptual properties can guide attention and eye movements in ways that assist and develop problem-solving insights. Thus, shifting attention towards a critical feature within an external representation can support effective interpretation.

Design principles adopted for the implementation of teaching resources

The category of the resources presented in this paper may be defined as pertaining to the sub-categories of symbolic and analogue models as defined by Baynes (2009). The modes of externalisation of these representations fall under the concrete, symbolic, visual and gestural categories as suggested by Gilbert (2007).

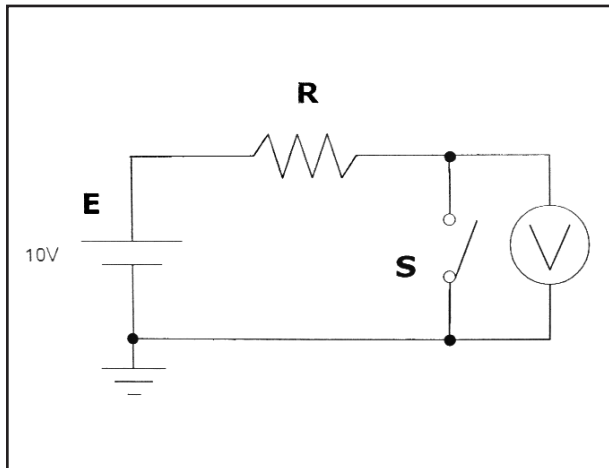

Figure 2. Typical textbook schematic 'pull-up' resistor

The external concrete representations use standard symbolic circuit symbols to illustrate the dynamic relationships of abstract variables such as voltage levels. This technique is combined with analogues that stem from mechanical devices such as springs, to predict the dynamics of salient points in the circuit. The main aim for selecting such a strategy was to enable the distribution of the cognitive process for understanding circuit behaviour as suggested by Zhang and Norman (1994). Thus, the resources serve not only as an extended working memory, but also as easy aids for perceptual inspection of rules, instead of mental verification. Rather than having to interpret the workings of each electronic device on its own, the resources also allow the learner to obtain an overall topology of the circuit as suggested by Cheng (1999; 2002), thus assisting the recognition of sub-circuit chunks and facilitating a sense of modularity of systems

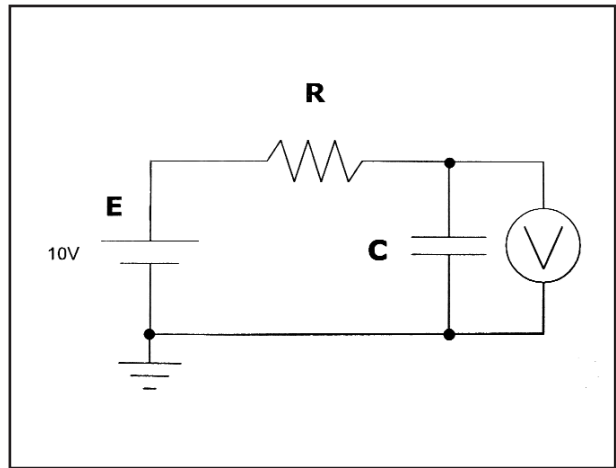

Figure 3. Typical textbook schematic for a charging capacitor

and scaffolding in more complex circuits (Egan and Schwartz, 1979).

The overarching principles were those proposed by Tversky et al. (2002), namely the Principle of Congruence and the Principle of Apprehension. These two principles were combined with general suggestions from other authors such as Grant and Spivey (2003), Zhang and Norman (1994), Smallman and St. John (2005), Alibali (2005) and Gilbert (2007) for identifying the features of best design practice of models and visualisation aids. The general principles taken from literature were then applied to the context of electronic circuits to give the following list of design rules for the planning and implementation of electronics teaching resources:

1. Adopt a spatial metaphor with loaded directions to stand for salient parameters in circuits.

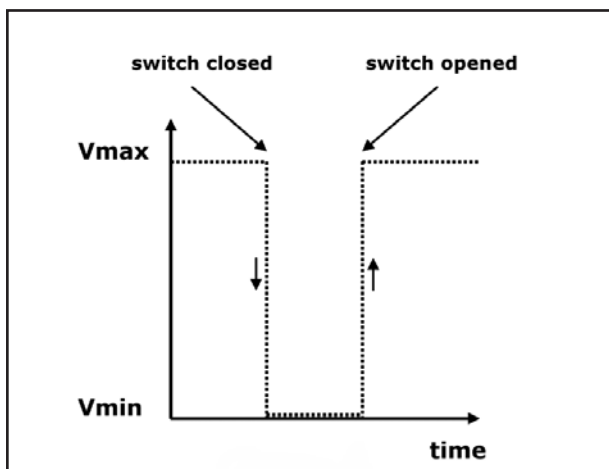

Figure 4. Step voltage drop on switch closure
Step voltage rise on switch opening

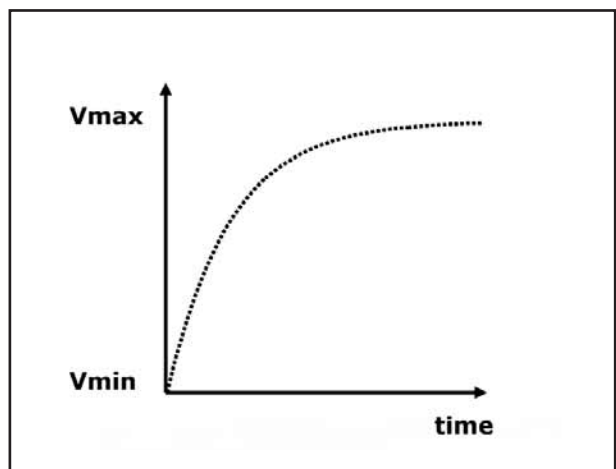

Figure 5. Exponential voltage rise across capacitor

Developing Novel Explanatory Models For Electronics Education

2. Schematise the circuit schematic.
3. Perceptually highlight salient points on the schematic and use analogues.
4. Use spatial symmetry when drawing circuit schematics.
5. Exploit the use of gesture.
6. Scaffold concepts.
7. Engage in interactivity.

Model design based on the seven design principles

The concepts of a 'pull-up' resistor and a charging capacitor were attempted first. Typical text book versions of these circuits are illustrated in Figures 2 and 3.

Figure 2 shows a battery, E, a resistor, R, and a switch, S connected in series. The voltmeter, V, measures the voltage across the switch when the switch changes state. With the switch open, the voltmeter reads 10V, while when the switch is closed it reads 0V. In a graphical format the voltage, with respect to time is illustrated in Figure 4.

Figure 3 shows a battery, E, a resistor, R, and a capacitor C connected in series. The voltmeter measures the voltage across the capacitor. When the battery is connected, the change in measured voltage will be exponential with respect to time as illustrated by the graph in Figure 5.

Spatial metaphors with loaded directions

For the proposed designs of circuits powered from d.c. voltage sources, the vertical dimension was used to stand for voltage levels or voltage potentials. Current, measured in Amperes, was not used as a salient parameter in these models. It was assumed that students were already familiar with Ohm's Law and the notions of voltage

potential, voltage difference, voltage drop and that voltage potentials are usually measured with respect to the electrical ground or assigned zero voltage point. The voltage potentials of salient points in the circuit therefore moved in between a vertical range delimited by the d.c. power supply rails.

Schematised circuit schematics

The symbol for the d.c. power supply was removed and replaced by thick horizontal lines that were vertically aligned but spaced apart. The thick horizontal lines were labelled with the values of the respective voltage levels. No measuring instruments were shown on the circuit schematic. When voltage potentials were referred to, it was conveyed by using hand gestures on the circuit schematics or on the cardboard models.

Figure 6 shows frames from an animated model of a pull-up resistor¹. The node attached to the resistor rises to its maximum upon opening the switch, a step change that reflects the measurement of the voltage. Figure 7 illustrates how cardboard models were designed to conform to the seven design principles.

Perceptually highlight salient points on the schematic and use of analogues.

Inter-component nodes were perceptually accentuated by drawing solid-filled black circles and by labelling. Instead of explaining the individual behaviour of devices in the circuit, attention was shifted over to the dynamic action of the salient nodes, which occurred according to how the electronic devices related to each other in the particular configuration given. It was assumed that students were

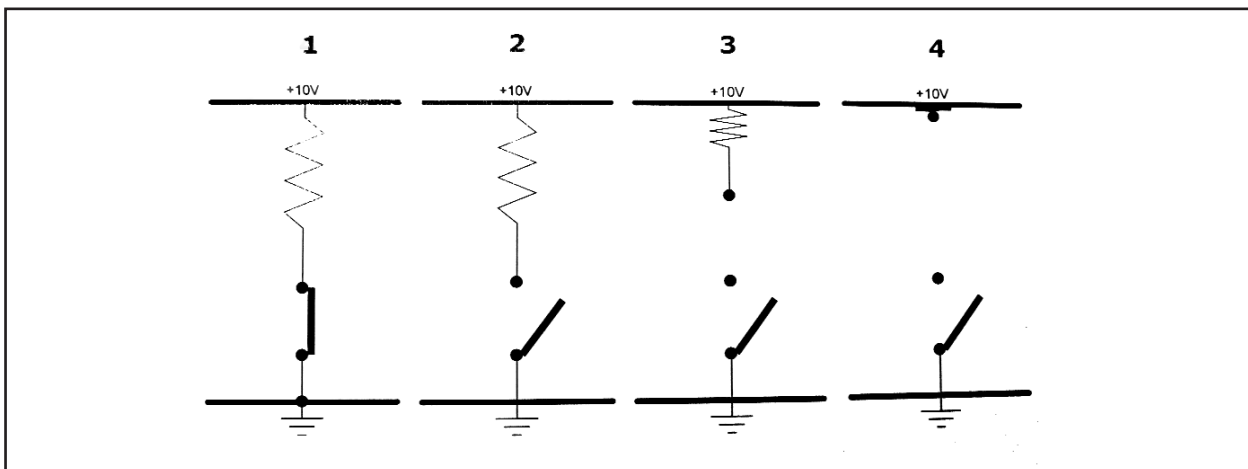

Figure 6. An alternative topology for a 'pull-up' resistor with switch (Frames of animation shown left to right, 1-4)

¹Examples of animations available at: <http://www.staff.lboro.ac.uk/~cdjrm/elec/animations>

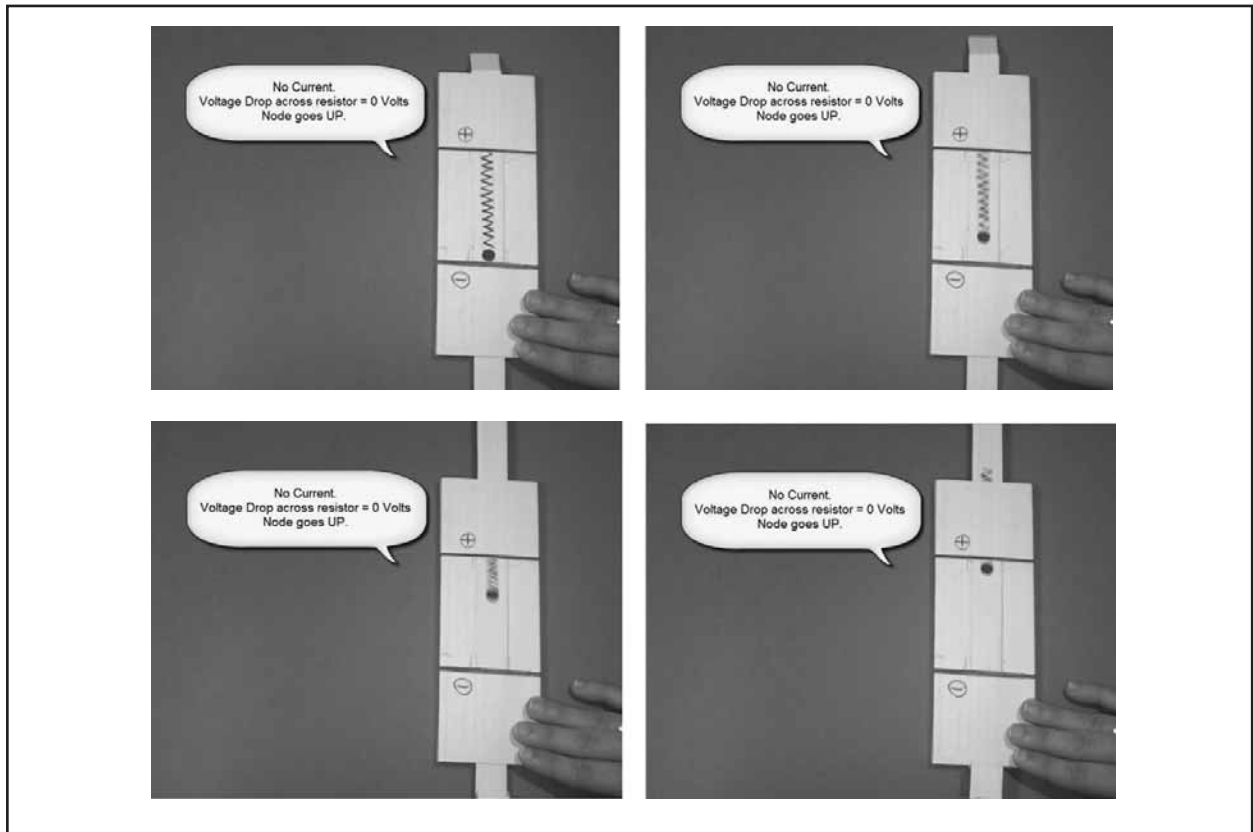

Figure 7. Card models of circuits ('Pull-up' resistor)

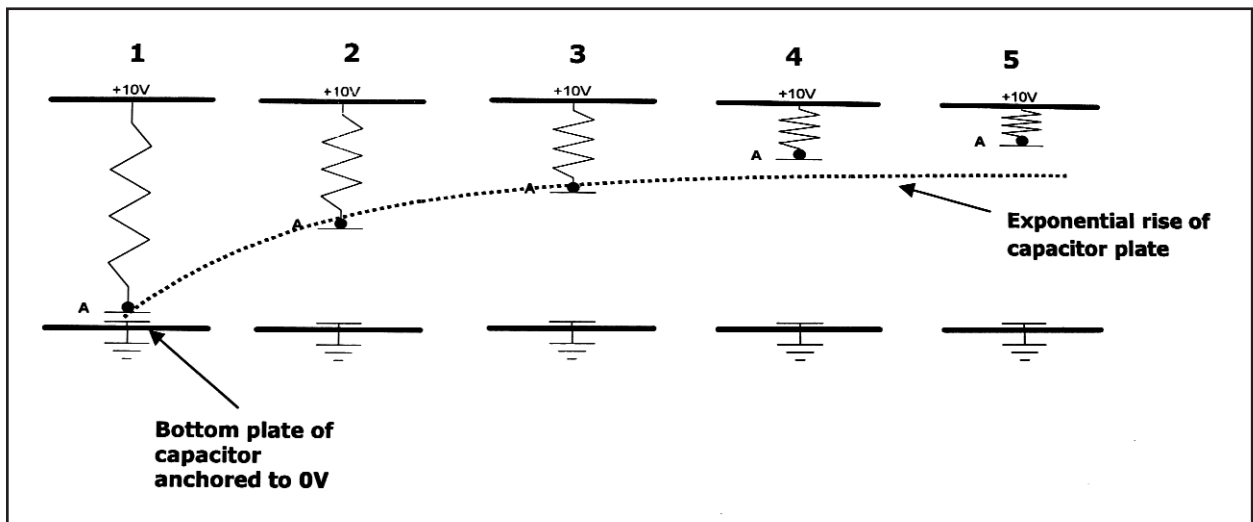

Figure 8. Animation frames of the voltage across a capacitor. The node dynamic plots an exponential curve

already familiar with the individual device characteristics. The choice of symbols was not only influenced by standard notations but also by which notation best served the formation of an effective mental model of the circuit behaviour. The symbol chosen for depicting a resistor is the American standard symbol not the European standard

symbol. This was done intentionally because the American standard symbol perceptually resembles a mechanical spring and some electronic concepts such as the action of a pull-up resistor, or a Wheatstone bridge (Figures 10, 11, 12 & 13) were found to benefit from the use of such an analogue even though the mechanical properties of a

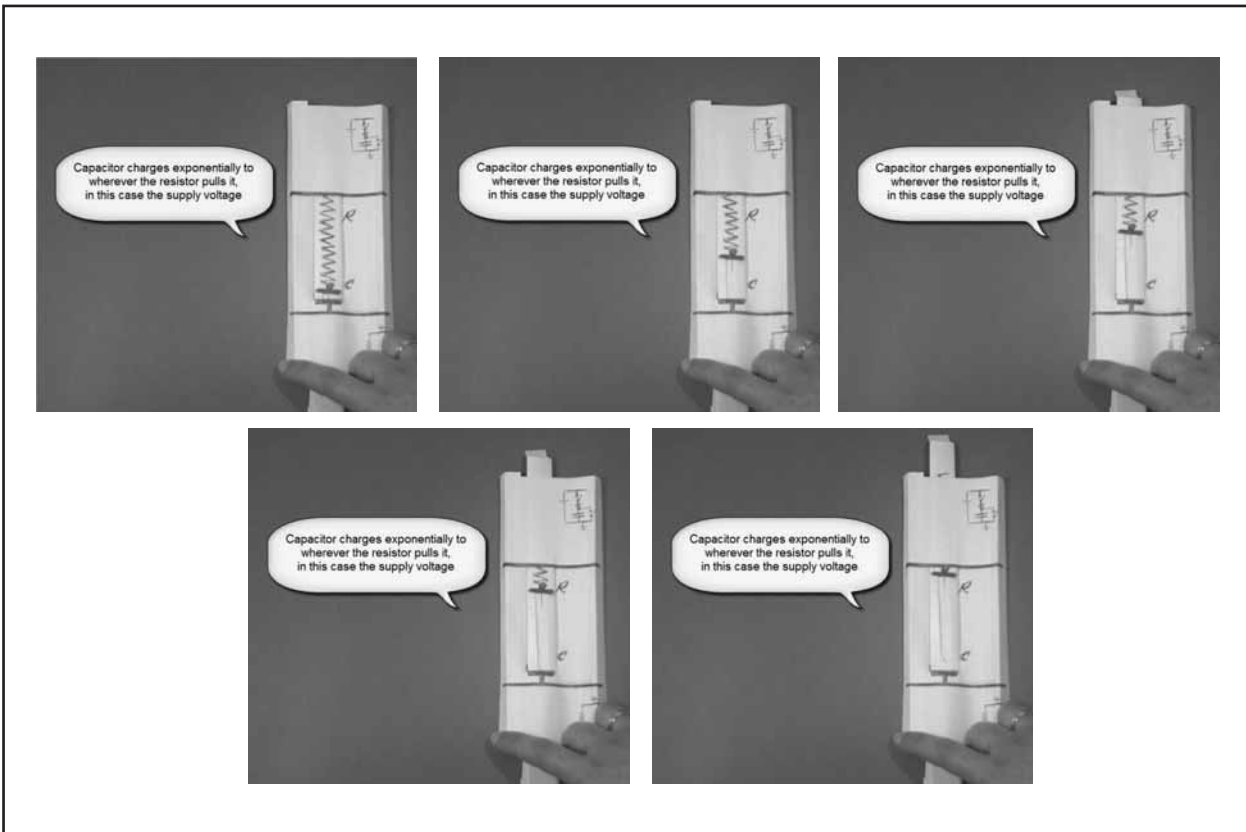

Figure 9. Card model implementation of the voltage across a capacitor

spring and the electronic properties of a resistor cannot be mapped directly. Symbols were also intentionally distorted perceptually (see Figure 8, capacitor symbol), where this aided the construction of a mental model that supported the respective electronics concept of device behaviour. In this instance the plates of a capacitor perceptually move apart while the capacitor is charging and the voltage across it increases. The distortion of the symbol must obey the laws of electronics. In the case of Figure 8, the lower plate of the capacitor is electrically grounded and therefore anchored to that point while the upper plate is free to be pulled up by the spring-like action of the pull-up resistor. The node, denoted by 'A' in the diagram, circumscribes the exponential curve of the voltage.

Use of spatial symmetry in circuit schematics

The use of a spatial metaphor necessitates that the circuit schematic is drawn to be compliant to the rules of the metaphor. The Wheatstone bridge depicted in Figure 10 was first redrawn as in Figure 11 for the vertically loaded spatial metaphor to be utilised naturally. A horizontal and vertical symmetrical H-structure (Figure 11) was found to be effective and applicable to many circuit configurations. Spatial symmetry not only facilitated the use of a spatial metaphor but also made more explicit the relationship

between sub-circuit behaviour. Providing a symmetrical referential visualisation of the concept of a circuit made its asymmetries stand out more effectively.

The Wheatstone bridge consists of two potential dividers, A-C and B-D. Varying the values of the resistors changes

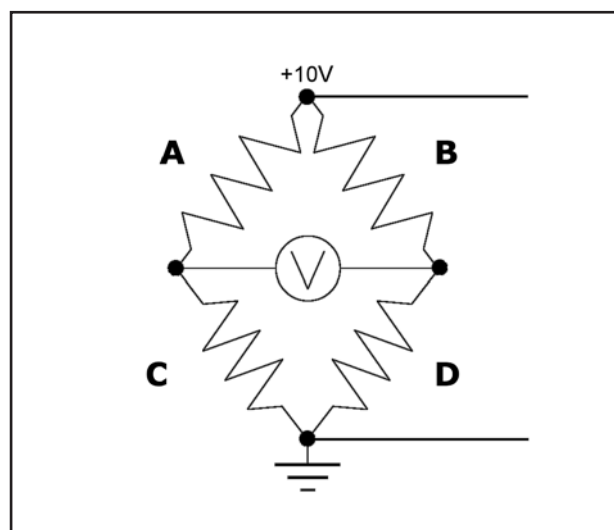

Figure 10. Wheatstone Bridge

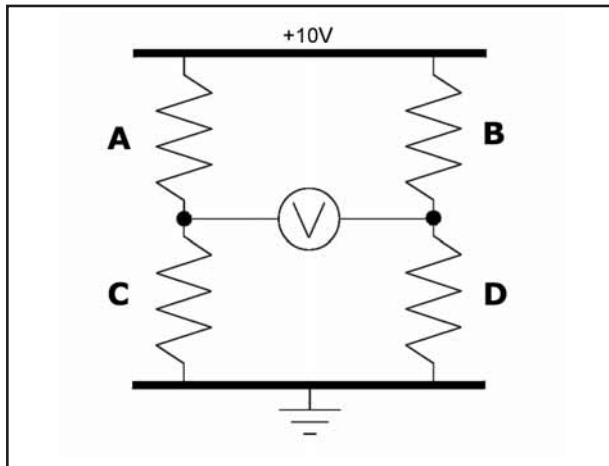

Figure 11. Alternative Wheatstone Bridge

the voltage measured at the nodes. The voltmeter measures the voltage difference between the nodes. Figure 12 shows animation frames illustrating how qualitative comparisons of voltages can be made through metaphorical changes in 'size' (in reality resistance value) of the resistors. When all four resistors are equal, as in Figure 12.3, there is a state of equilibrium in the system and the voltage difference measured is zero.

Exploitation of gesture

The size of the cardboard models was designed so that they can be easily hand held. The physical design was such that the salient nodes may only move and take their positions according to the adopted spatial metaphor. However, the sequence and velocity with which the salient nodes move was left to the user to plan. Thus, the model may be operated in discrete steps or continuously and may be started, paused or stopped at any stage of the process.

Scaffolding concepts

The scaffolding of concepts was achieved in two ways: by gradually increasing circuit complexity and by maintaining a topological sequence for the circuit schematics as shown in Figure 14. More complex circuits were always built on previous less complex ones or those that were conceptually related. In this way the recognition of sub-circuit chunks was facilitated both conceptually and visually.

Interactivity

The diagrams shown from the schematised circuit schematics in Figures 6, 8, 12 are frame stills from a

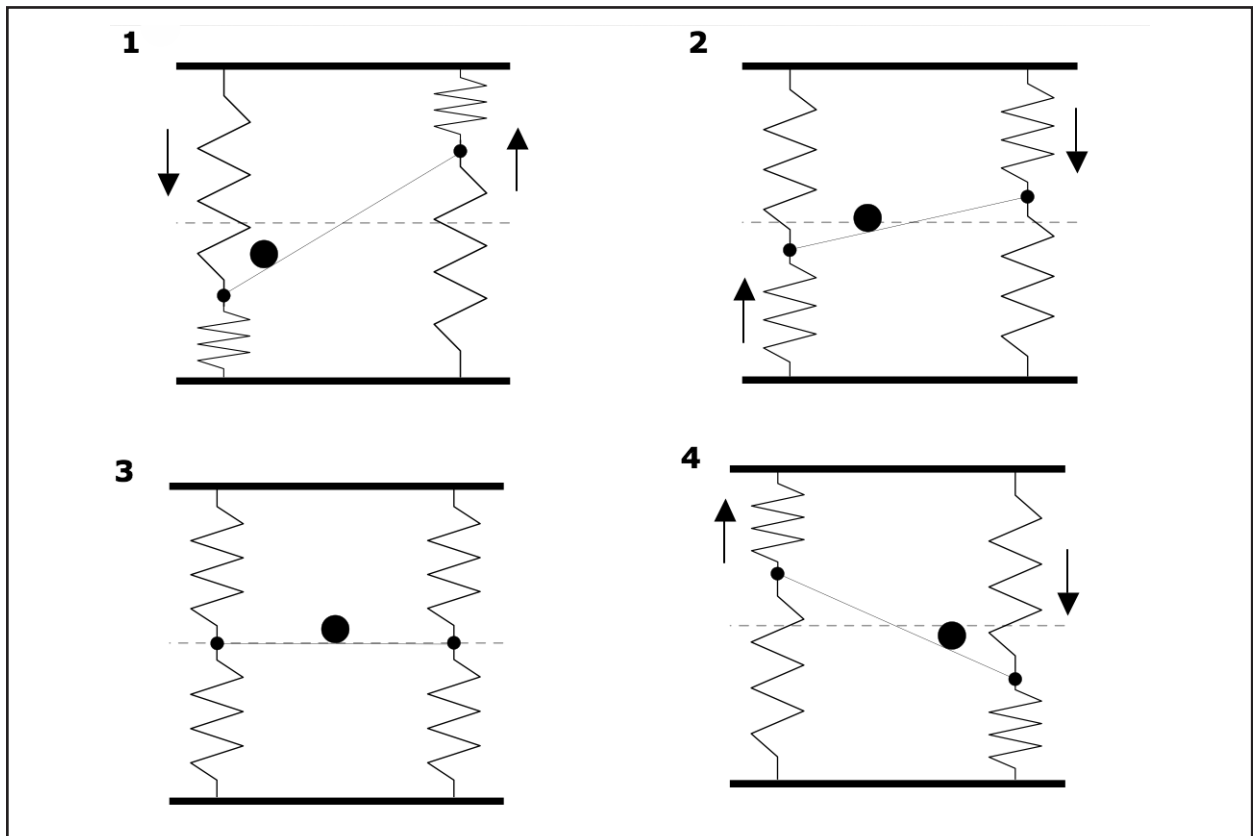

Figure 12. Alternative Wheatstone bridge animation frames

Developing Novel Explanatory Models For Electronics Education

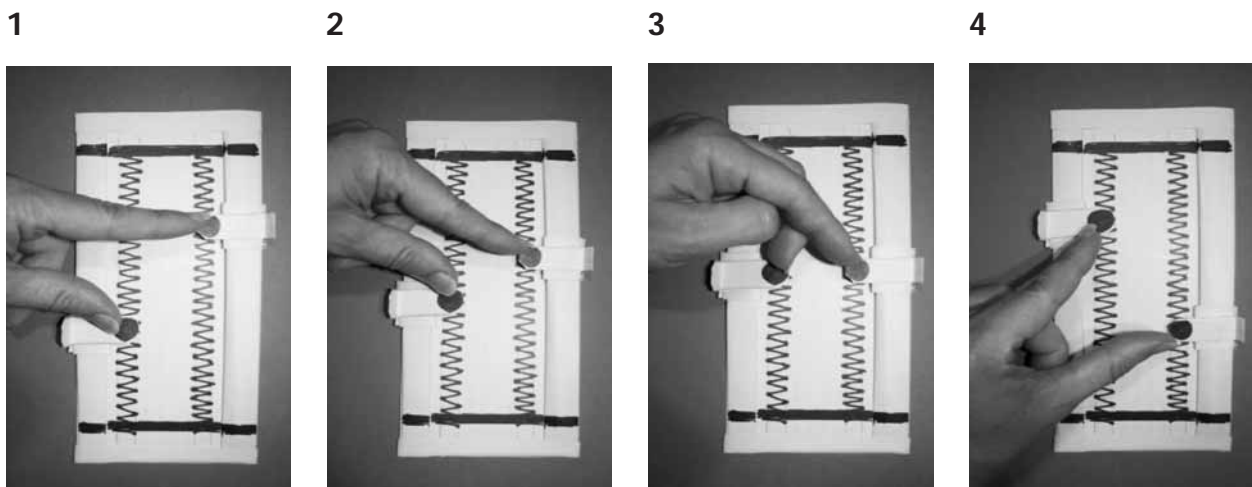

Figure 13. Card based Wheatstone Bridge with corresponding gestures)

software animation. In the present work these animations demonstrate the conceptual sequence of how the electronic circuits work, but they could also easily lend themselves to being interactive by allowing the user to interrupt the sequence or change component parameters in the animation itself.

Figure 14 A-E are building blocks (now adopting the European standard notation) that can be used to connect to more complex circuits.

Method of testing resources

Interviews with Lecturers

Eight engineering lecturers from the University of Malta

(UOM) were approached to give their feedback on the designed teaching resources. The primary aim of the interviews was to establish a rapport and gain permission to access students for further study, while also gauging the acceptance of such resources by experts in the field. The interviews started by sharing students' commonest difficulties in basic engineering topics and therefore, which areas could benefit most from the use of such resources. The lecturers were also questioned about the nature of the materials such as whether the resources were seen to be beneficial for students with wide ranging abilities. Finally, the interview with lecturers was also to monitor experts' reactions and recognition of the circuits given in the resources. The researcher could not interview D&T

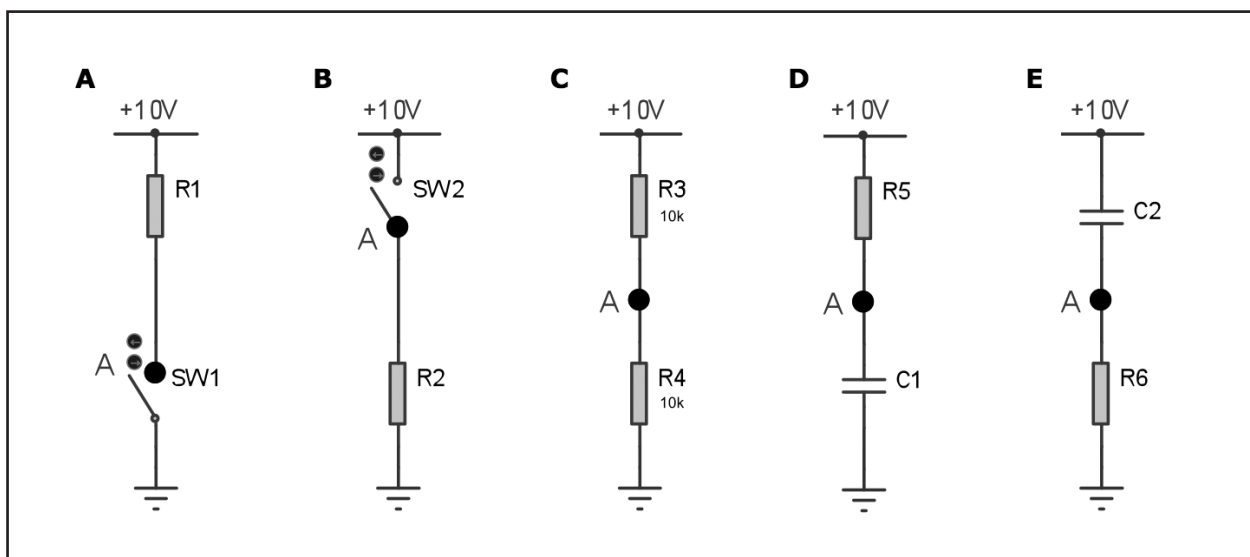

Figure 14. Nodal concepts A) Pull-up resistor B) Pull-down resistor C) Potential divider D) Charging capacitor (exponential increase of node) E) Charging capacitor (exponential decrease of node)

Developing Novel Explanatory Models For Electronics Education

lecturers because for this particular course at UOM, there are no other lecturers for electronics other than the researcher herself.

Profiling student participants.

Nine undergraduate students from UOM participated in a preliminary study. There were five Design and Technology (D&T) students enrolled in a teaching programme and four Engineering students who were enrolled in the electrical branch of an engineering programme. Both sets of students were in their final year of study. The sampling strategy for this study was selected on the basis of convenience. The final year for the D&T course at the UOM included only five students so, the latter were representative of all D&T students for that particular year. The researcher was introduced to the engineering students while discussing the research topic with a lecturer at the Faculty of Engineering. Although perhaps not representative of the electrical engineering programme, all students were familiar with the electronic circuits mentioned in this research since the topics tackled form part of the curricula for D&T and Engineering courses.

Experimental Design and Procedure

Students were selected according to their programme of study and interviewed as a group using an open-ended, semi-structured technique while being exposed to the bespoke teaching resources. The advantages of group interviewing included the potential for discussions to develop and yield a wide range of responses, including observed reactions. Organisational advantages such as timesaving and the minimal disruption of lectures was also a key issue. The disadvantage of group interviews was that it allowed limited personal matters to emerge. This influenced the analysis of data which could only be interpreted in terms of the group. Data was expected in the form of unstructured responses and therefore, the researcher used themes to guide the interviews. She asked probing questions while also offering the respondent the possibility to express oneself by writing words, drawing or problem solve with mathematics if this need was felt. The guiding themes for the interviews were mainly on possible learning styles, the use of qualitative methods of teaching and the modelling of circuits and resources that involved gesturing rather than computer simulations or mathematics.

Interviews with D&T students

With D&T students the group interview occurred as part of the students' own lecture about teaching methodologies that could be suitable for electronics education. The physical environment selected was the D&T workshop at the UOM, a location that was frequented daily by these

students for four years, and which therefore was a familiar, unthreatening environment for them. The interview was conducted in an informal, conversational style which blended well with the lecturing style usually used by the lecturer. Interviews with D&T students enabled the researcher to gain feedback about the resources both directly and indirectly. The direct method involved the gauging of the undergraduate's understanding of the electronic concept by questioning about circuit behaviour. The indirect method involved asking the student-teachers if they would be ready to adopt the novel resources in their own teaching style with children, and, to suggest any changes to the resources.

This method was inevitably subject to some interpretation of the outcome of the discussions on the researcher's part. A tendency of biased responses from the students' part was also possible in the D&T case since the researcher, as lecturer, had already used some of these methods to teach electronics in previous years of the course although, at the time, the teaching method was not analysed.

Interviews with engineering students

The Engineering student cohort was accessed through gradually building a rapport with lecturers and students at the Faculty of Engineering at the UOM. As a pilot study, one lecturer offered to introduce the researcher to four students who were working on their engineering thesis at the time. The physical environment for the interviews was the electronic engineering laboratory where students had their own project set up, and the time allocated usually depended on the students' commitments so that sometimes, more than one meeting was necessary. The interview was conducted in an informal, conversational style so that the students would feel at ease. Feedback about the resources was only gained directly in this case, by questioning about circuit behaviour.

The researcher was a complete stranger to engineering students, and therefore, the tendency of biased responses was significantly reduced in this case. Subjective interpretation was still possible since the researcher was the only interviewer.

Student interpretation of the models

For the models in Figure 6, D&T students first interpreted the representations as physical models rather than conceptual models of the voltage levels taken by salient nodes in the circuits. This was observed when, during the interview, all D&T students asked if the resistor was being physically compressed or squashed. Electrical Engineering students never inquired about this and seemed to take it

Developing Novel Explanatory Models For Electronics Education

for granted that the models were conceptual. D&T students were also puzzled by the fact that the animated models did not show the familiar standard symbol of the power supply. Once again, in contrast to Electrical Engineering students who tended to assume the presence of a d.c. power supply, D&T students viewed that the circuit was not powered at all. A focused discussion about this issue with D&T students revealed that they felt they were pre-conditioned by their previous knowledge to visualise circuits in loops as in the typical text book schematics of Figures 2 & 3 rather than with a vertical spatial metaphor and that the latter involved some effort of interpretation on their part. Electrical Engineering students seemed to consider the transition in between representations to be quite effortless. D&T students also stated that they usually think of numerical values when solving problems of voltage potentials rather than conceptual levels on a pictorial plane. It is possible that this is indicative of their exposure to traditional numerical education of the subject, regardless of their preference. The feedback on both the animated representations and the cardboard models obtained by D&T students was seen to concern mostly the visual aspect of the display, while Electrical Engineering students commented on more abstract features such as the difference in velocity with which the salient node goes up when comparing the pull-up resistor circuit to the resistor-capacitor circuit. Most Electrical Engineering students' comments centred around the accuracy of the abstract dynamics of the node behaviours rather than the visual aspect of the models.

It was found that students' reactions to the novel teaching aids were positive once they understood what the resources represented. Overcoming the initial barrier of misinterpretation did not take too much time and students commented positively on the fact that they were presented with a different perspective of how to interpret and think about electronic circuits. D&T students commented that this was especially important for them since they seem to have difficulty with formal, mathematical, analytic methods. It may be the case, as Larkin and Simon (1987) suggested, that D&T students lack the knowledge necessary for recognising relevant information and for drawing inferences from that information and therefore need additional supports to guide their search processes through different modes of representation (Gobert, 2007).

Themselves being trained as teachers, D&T students regarded such qualitative resources as being potentially useful for teaching D&T in secondary schools. For electrical engineering students, formal analytic methods seemed to be less of a problem but, some students admitted that

they still had difficulty in understanding and visualising exactly how a circuit worked even though they could get the mathematical analysis correct. Being able to think about circuits qualitatively and recalling circuit dynamics by the use of gestures, symmetry and attentional shifts seemed to help students retain the conceptual knowledge of the electronic circuit better. Most students have shown better fluency in the transitions between macroscopic level observations obtained from their laboratory experiments or project design work with respect to the symbolic conceptual qualitative levels presented by the teaching aids. This may be so because they could release the mental burden of electronic rule checking by looking at the external representation, as suggested by Zhang and Norman (1994).

Electrical Engineering lecturers expressed reactions that support what students said. They emphasised that such qualitative resources should not replace more rigorous forms of analysis, but they may be useful both for strugglers and high-achieving students in complementing the latter methods for better understanding of the subject. Some lecturers were also willing to adopt the use of such resources in their lectures if the teaching aids were tailor made for their needs.

Limitations of the Design Principles

A misconception of how a pull-up resistor works was revealed by the model shown in Figure 6. During the group interview, all Design and Technology students experienced the misconception that some voltage potential was being developed across the switch when the switch was in the ON position because while the resistor symbol was compressed until the inter-component node reached the upper rail, signifying that the value of the voltage across the switch with respect to the electrical ground point was +10V; the switch symbol was not distorted or compressed to signify that the inter-component node reached the lower rail, and so, that the value of the voltage across the switch with respect to electrical ground was 0V. This was not the case with Electrical Engineering students. It seems that for D&T students the visual vertically loaded spatial metaphor of the switch symbol was taking priority over the more abstract mental model of a closed switch acting as a short circuit to the ground point. This exemplifies a case where the visual perception may have influenced the visual imagery negatively (Reisberg, 1997, Gilbert, 2007). It was therefore decided to modify the representation of the pull-up resistor and schematise it further by removing the switch symbol as in Figure 15. This latter model was found to create much less misconceptions with D&T students.

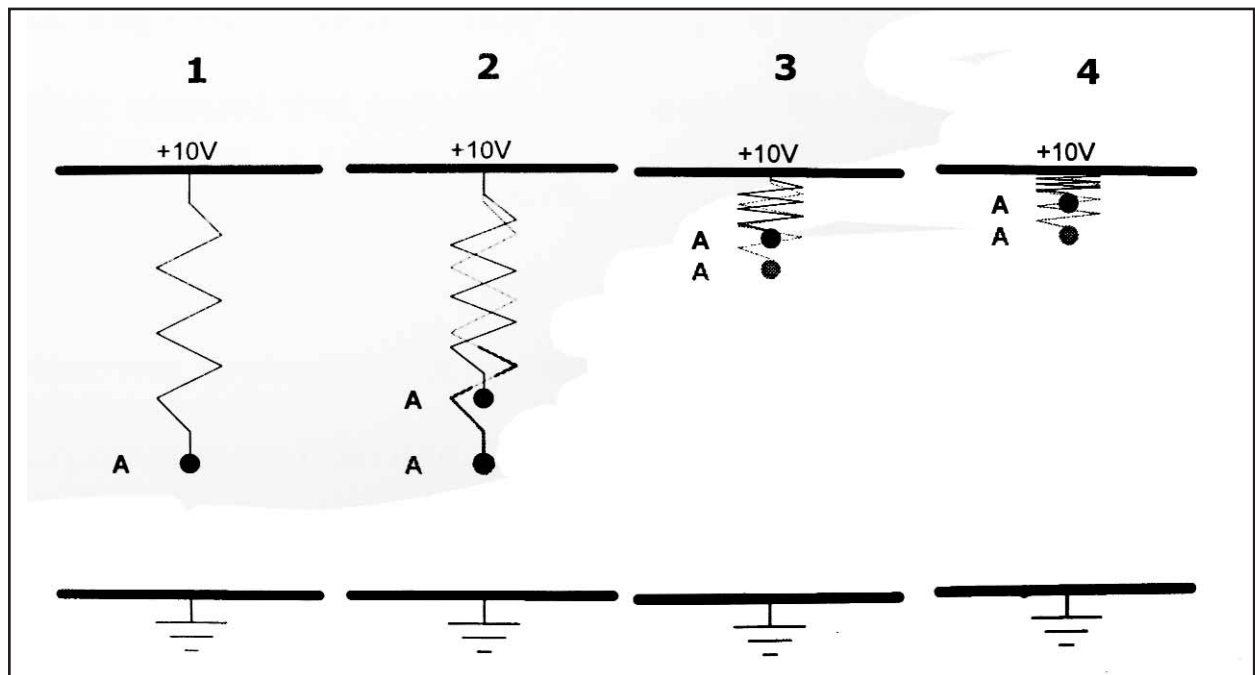

Figure 15. An alternative topology for a 'pull-up' resistor (Frames of animation shown left to right, 1-4)

Conclusions

This paper has explored the effects that external representations and abstract models may have on the understanding of electronic concepts, and how such representations may be designed to help students, with different learning styles, achieve successful comprehension of the field of electronics. The preliminary findings indicate that a particular external representation of a circuit may offer representational determinism (Zhang, 1997) and may have positive or negative effects on conceptual understanding and, in itself, may create misconceptions about electronics concepts.

The interpretation of a novel representation may be dependent on a student's learning style or the individual's prior knowledge (Larkin and Simon, 1987). Different representations, as simple as the re-drawing of a circuit in a particular way may help a learner develop different perspectives on how to think about a problem. There may also be ideal design principles on how to present electronic circuit schematics or other models depending on the learning outcomes desired.

Effective teaching aids or methods may be designed to be more qualitative, having an active, dynamic element that appeals to the senses. The designs may be more abstract and favour a reflective, intuitive approach.

Successful teaching strategies that are found effective with the majority of students may need to incorporate more

than one design technique. Presenting a comprehensive picture of the field of electronics may necessitate that qualitative and formal analytic techniques complement each other.

Recommendations and further research

This research intends to continue investigating methodologies for teaching the field of electronics and their effects on different types of learners. It is proposed that teaching aids are designed according to the principles mentioned and adapted to various levels of electronics education. The aim is to produce interactive software animated and hardware teaching resources for selected topics within the context of an electronics curriculum.

Acknowledgements

With thanks to Professor Carmel Pulé for his general advice and to Mr Keith Buhagiar for his assistance in photography.

Developing Novel Explanatory Models For Electronics Education

References

- Alibali, M. W. 2005. Gesture in Spatial Cognition: Expressing, Communicating, and Thinking About Spatial Information. *Spatial Cognition and Computation*, 5, 307-331.
- Baynes, K. 2009. Models of Change: The impact of 'designerly thinking' on people's lives and the environment. In: Norman, E. (ed.) *Seminar 1: Modelling and Intelligence*.
- Cheng, P. C. H. 1999. Unlocking conceptual learning in mathematics and science with effective representational systems. *Computers and Education*, 33, 109-130.
- Cheng, P. C. H. 2002. Electrifying diagrams for learning: principles for complex representational systems. *Cognitive Science*, 26, 685-736.
- Egan, D. E. & Schwartz, B. J. 1979. Chunking in recall of symbolic drawings. *Memory and Cognition*, 7, 149-158.
- Gilbert, J. K. 2007. Visualization: A Metacognitive Skill in Science and Science Education. In: GILBERT, J. K. (ed.) *Visualizations in Science Education*. Springer.
- Gobert, J. D. 2007. Leveraging Technology and cognitive Theory on Visualization to Promote Students' Science Learning and Literacy. In: Gilbert, J. K. (ed.) *Visualization in Science Education*. Springer.
- Grant, E. R. & Spivey, M. J. 2003. Eye Movements and Problem Solving: Guiding Attention Guides Thought. *Psychological Science*, 14, 462-466.
- Hostetter, A. B., Alibali, M. W. & Kita, S. 2007. I see it in my hands' eye: Representational gestures reflect conceptual demands. *Language and Cognitive Processes*, 22, 313-336.
- Kolari, S. & Savander-Ranne, C. 2004. Visualization Promotes Apprehension and Comprehension. *International Journal of Engineering Education*, 20, 484-493.
- Larkin, J. H. & Simon, H. A. 1987. Why a Diagram is (Sometimes) Worth Ten Thousand Words. *Cognitive Science*, 11, 65-99.
- Rapp, D. N. 2007. Mental Models: Theoretical issues for Visualizations in Science Education. In: Gilbert, J. K. (ed.) *Visualization in Science Education*. Springer.
- Reisberg, D. 1997. *Cognition: Exploring the Science of the Mind*, New York, Norton.
- Stenning, K. & Oberlander, J. 1995. A Cognitive Theory of Graphical and Linguistic Reasoning: Logic and Implementation. *Cognitive Science*, 19, 97-140.
- Tversky, B. 2007. Prolegomenon to Scientific Visualizations. In: Gilbert, J. K. (ed.) *Visualization in Science Education*. Springer.
- Zhang, J. 1997. The Nature of External Representations in Problem Solving. *Cognitive Science*, 21, 179-217.
- Zhang, J. & Norman, D. A. 1994. Representations in Distributed Cognitive Tasks. *Cognitive Science*, 18, 87-122.

sarah.pule@um.edu.mt
j.r.mccardle@lboro.ac.uk