

## 31st WEDC International Conference, Kampala, Uganda, 2005

### MAXIMIZING THE BENEFITS FROM WATER AND ENVIRONMENTAL SANITATION

# Design of a modified dry toilet ventilation systems to accelerate drying

M.K. Ntabadde, C. Niwagaba, A.I. Rugumayo

*A study was carried out to develop a modified ventilation system to accelerate drying, which would be useful in shortening the retention period required before faecal matter can be rendered safe for handling. This would result in smaller units and reduced overall costs. The data analysed showed that all the Ecosan systems were operating on natural ventilation, but often with a number of shortcomings such as small vent pipe diameters as well as, improper and weak materials. It was concluded that a minimum vent pipe diameter of 150mm is required for efficient ventilation and better results could be obtained by incorporating a rotary vent turbine. The rate of drying in the vaults could be further increased by the use of one-way glass for the vault covers and insulating the walls, to optimise direct sunlight and minimize heat loss. These conditions are very important, if accelerated drying is to be realised.*

## Introduction

To promote the concept of ecological sanitation in Uganda, pilot units were constructed in Kisoro and Kabale districts from 1997, by the Directorate of Water Development (DWD) under the South-Western Towns Water and Sanitation (SWTWS) project. The SWTWS project has since constructed over 500 units. The dehydrating (dry) EcoSan systems are preferred to composting systems in Uganda due to the convenience in handling of faecal matter after drying. Also according to Esrey et al, 1998, dehydrating methods are said to kill pathogens more effectively than other simple methods.

Despite the enormous benefits of Ecosan systems, they still have a number of constraints in their design, which restrict optimum performance. Among these is the low rate at which faeces in the dehydrating vaults dry up. Thus there is need to develop an improved design of the ventilation system and other components to accelerate drying of the faecal matter which would result in shorter retention periods before the faecal matter can be rendered safe for handling. Thus providing smaller and more cost effective dehydrating ecosan units.

In a research carried out at Makerere by John Senkungu to investigate the efficiency of the ecosan with modified ventilation, a ten percent moisture content reduction on average was realised in the improved model ecosan, more than was realised in the control ecosan.

## Objectives

The main objective of the study was to design an innovative dry toilet ventilation system to accelerate drying.

The specific objectives were:

- To study the ecological sanitation systems available, their performance and operation;

- To identify shortcomings in the design and operation of current systems;
- To produce adequate modifications to accelerate drying, depending on the findings above;
- To develop a model of the modified system,
- To produce design drawings of the modified system with the aid of a CAD software,
- To estimate the cost of construction of the modified ecosan toilet.

## Materials and Methods

### Site Visits

Site visits were made to the SWTWS project area in order to obtain the necessary information on Ecosan systems. A random sample of twenty units was selected and analysed to get a qualitative representation of the characteristics of the entire population of about two hundred dehydrating ecosan units within the sampled area.

Twenty questionnaires were used to establish general information whereas checklists were used to record more technical information obtained either by measurement or observation. For quality control, all measurements taken were averaged from at least three values.

### Selection of materials and sizing of components

#### Introduction

Natural ventilation is driven by pressure difference across the building envelope, caused by wind and/or a difference in air density due to temperature differences (stack/thermal effect) between indoor (or vent pipe) and outdoor air (Archhku, 2001).

In order to maximise airflow through the ventilation system due to thermal effect, the temperatures within the vaults and the vent pipe should be maximised and the stack height (vent pipe height) optimised (Lowndes, 2000).

**Selection of vault materials**

A material with a high transmittance was selected for the vault doors and for the walls; materials were selected so as to have much of the heat absorbed within the processing vaults being retained, by providing some kind of insulation. Thus one-way glass was selected for the vault doors because it allows in direct sunlight in one direction into the vaults and hinders light-movement in the reverse direction. A double wall was selected for the vaults with a small space between the two walls to accommodate some form of insulating material that may be available.

**Sizing of the vent pipe**

The pipe diameter size was selected such that the recommended ventilation rate of 20m<sup>3</sup>/hr could be achieved either by thermal effect or stack effect, assuming there would be a point when the system would be operating independently, either on thermal or stack ventilation.

The predominantly used size of 100mm diameter was checked to establish if it can achieve the recommended ventilation rate of 20m<sup>3</sup>/hr. Having been found inadequate, a larger size of 150mm was tested.

The ventilation rate due to the wind effect was calculated using equation 1 (Arch-hku, 2001)

$$Q = C_v A v \dots \tag{1}$$

Where

Q = air flow rate (m<sup>3</sup>/s)

A = free cross-sectional area of vent pipe inlet opening (m<sup>2</sup>)

v = wind velocity

C<sub>v</sub> = effectiveness of the opening (0.25 to 0.36 for diagonal winds)

For design purposes as the wind velocity used was half the average seasonal wind velocity calculated because from climatic analysis there are very few places where wind speed falls below half the average for many hours in a year (Arch-hku, 2001).

The ventilation rate due to stack effect was calculated using equation 2 (Arch-hku, 2001)

$$Q = K A \sqrt{2 \cdot g \cdot \Delta h \cdot (T_i - T_0) / T_i} \dots \tag{2}$$

Where

Q = air flow rate (m<sup>3</sup>/s)

K = Discharge coefficient for opening (usually assumed to be 0.65)

A = free cross-sectional area of vent pipe (m<sup>2</sup>)

Δh = height of vent pipe (m)

T<sub>i</sub> = Vent pipe air temperature

T<sub>0</sub> = Outdoor air temperature

The temperature values used were measured for selected units in Kabale-Kisoro and Mbarara for three consecutive days, three times each day (at 7.00am, 2.00pm and 7.00pm) and the average values used.

**Selection of a rotary vent turbine**

Ventilation systems operating purely on natural ventilation have been found not to be very effective, (Liddament, 1996), especially when poorly designed. A mechanical wind-driven

turbine (turbine vent) was therefore incorporated into the design to accelerate the rate of evaporation from the processing chambers.

**Construction of a model**

A model of the designed ecological sanitation toilet was constructed at a scale of 1:4, using 9mm thick plywood. The vault doors were made of 5mm-thick one-way glass and the vent pipe was fabricated from 1.2mm-thick mild steel plate. The rotary vent air extractor of 14 blades was locally fabricated from aluminium.

**Table 1. Qualitative Summary of the results**

Height of vent pipe above roof (m)	<0.5	0.5-0.7	>0.7
Number	8	8	4
Percentage	40	40	20
Orientation of the vault doors	Vertical	Slanting	Horizontal
Number	6	12	2
Percentage	30	60	10
Number and location of vent pipes per stance	1, centre of 2 vaults	2, centre of each vault	2, at centre of each vault
Number	11	7	2
Percentage	55	35	10
Vent covers	With	Without	
Number	13	7	
Percentage	65	35	
Pipe material	PVC	Others	
Number	20	Nil	
Percentage	100	0	

**Results and Discussion**

**Field results**

The results obtained from the site visits in Kabale, are summarised in Table 1. From the results, it can be observed that;

- A good percentage of the dry toilets had slanting vault doors made of 1.2mm gauge steel plates painted black to increase the amount of heat absorbed, thus accelerating the rate of drying and the rate of die-off of pathogens in the processing vaults (Moe Christine and Izurieta Ricardo, 2003)
- Only twenty percent of the twenty units had vent pipe height above the ideal recommended height above the roof to prevent interference to wind flow due to turbulence around the top of the pipe (at least 0.5m above the highest point of the roof).

- Thirty five percent vent pipes of the twenty units visited were without vent caps, thus rain would find its way through the vent pipe into the processing vaults thus increasing the moisture content in the vaults.
- Sixty percent of the toilets had one vent pipe aerating two vaults. This was done in such a way that a groove would be created in the upper part of the partitioning wall between the two vaults and the pipe fixed just above this space. This approach greatly hinders the free flow of air into the vent pipe since the effective area of entry is reduced, thus reducing the rate of ventilation (Parmley *et al*, 1988).
- One hundred percent of the units had 100mm diameter PVC pipes of a poor grade, which was easily damaged.

**Design of Ventilation System**

**Sizing of Vent Pipe**

In order to come up with an appropriate size for the pipe, equations 1 and 2 were used to calculate the ventilation rates due to stack and wind effects that would be obtained by the sizes of 100mm and 150mm diameter. By substitution of the necessary parameters into equations 1 and 2 the results in Table 2 were obtained.

**Table 2. Ventilation Rates achieved by different diameters**

Pipe Diameter (mm)	Ventilation due to Thermal effect (m <sup>3</sup> /h)		Ventilation due to Wind Effect (m <sup>3</sup> /h)		Recommended value (m <sup>3</sup> /h)
	100	150	100	150	
Kabale	16	37	13	28	20
Kisoro	15	36			

From the results obtained, the 100mm diameter pipe was found in all cases not to achieve the recommended ventilation rate of 20m<sup>3</sup>/hr. Whereas in all cases the 150mm diameter pipe achieved the recommended value. Since all other variables in the equations 1 and 2 will remain constant for a given area (and constant height), the only variable that could change the ventilation rate Q will be the pipe Diameter. The minimum pipe diameter for effective ventilation in the toilet was thus concluded to be 150mm.

**Design of Vault walls**

An attempt was made to maximise the temperatures in the vaults so as to accelerate drying. This was achieved by incorporating insulating materials with a higher R-Value, (this is a measure of resistance to heat flow that a given material offers). A double wall was used with the space between the walls having half-inch gypsum board and quarter-inch plywood. The new design of the wall had an R-value three (2.93) times that of the single wall (0.96) This would imply that a given amount of heat conducted through the single wall in a given time (t) would take three times (3t) the same time to be conducted through the double wall.

**Vault Doors**

One-way glass was used for the vault doors, to maximise the temperatures within the processing vaults, to accelerate drying. Though glass is a vulnerable material susceptible to damage, the material could be protected by use of a wire mesh of appropriate spacing tightly stretched over the glass, leaving a clearance of a few centimetres between the glass and the mesh. This would shield the glass from foreign objects that could damage it.

**Cost**

The design plus construction of a one stance Ecosan unit of the proposed design was estimated at 1.4million Uganda shillings (about US\$850)

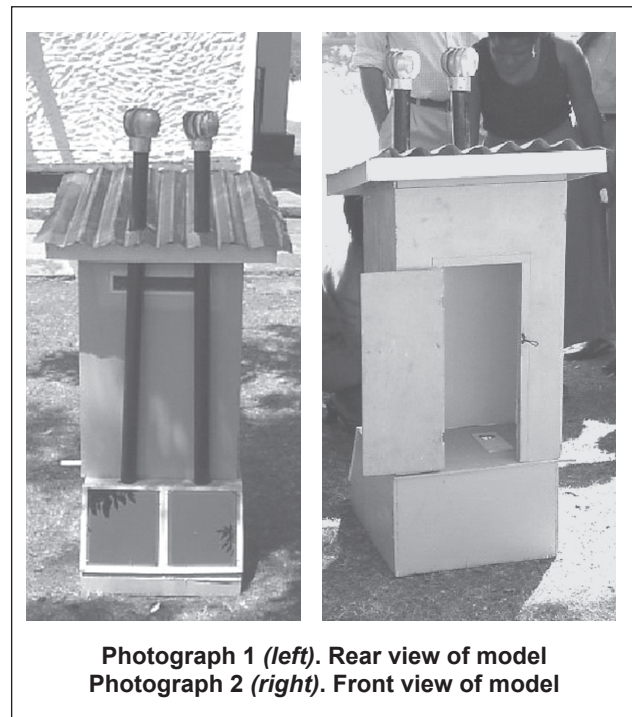

**Photograph 1 (left). Rear view of model  
Photograph 2 (right). Front view of model**

**Conclusions and Recommendations**

**Conclusions**

- All systems visited were operating purely on natural ventilation. Many times there was no flow recorded in the vent pipes especially those with a small vent pipe bore.
- It was concluded that a pipe diameter of at least 150mm is required for effective ventilation. Incorporating a rotary vent turbine would greatly increase the rate of extraction of evaporated water from the vaults.
- Temperatures in the vaults could be maximised by use of one-way glass to allow in as much direct solar radiation as possible into the vaults and use of insulating materials within the walls to ensure that the heat absorbed is not easily lost.
- The proposed improvements can be carefully selected so as to achieve increased rates of drying to some extent, without necessarily having escalated prices.

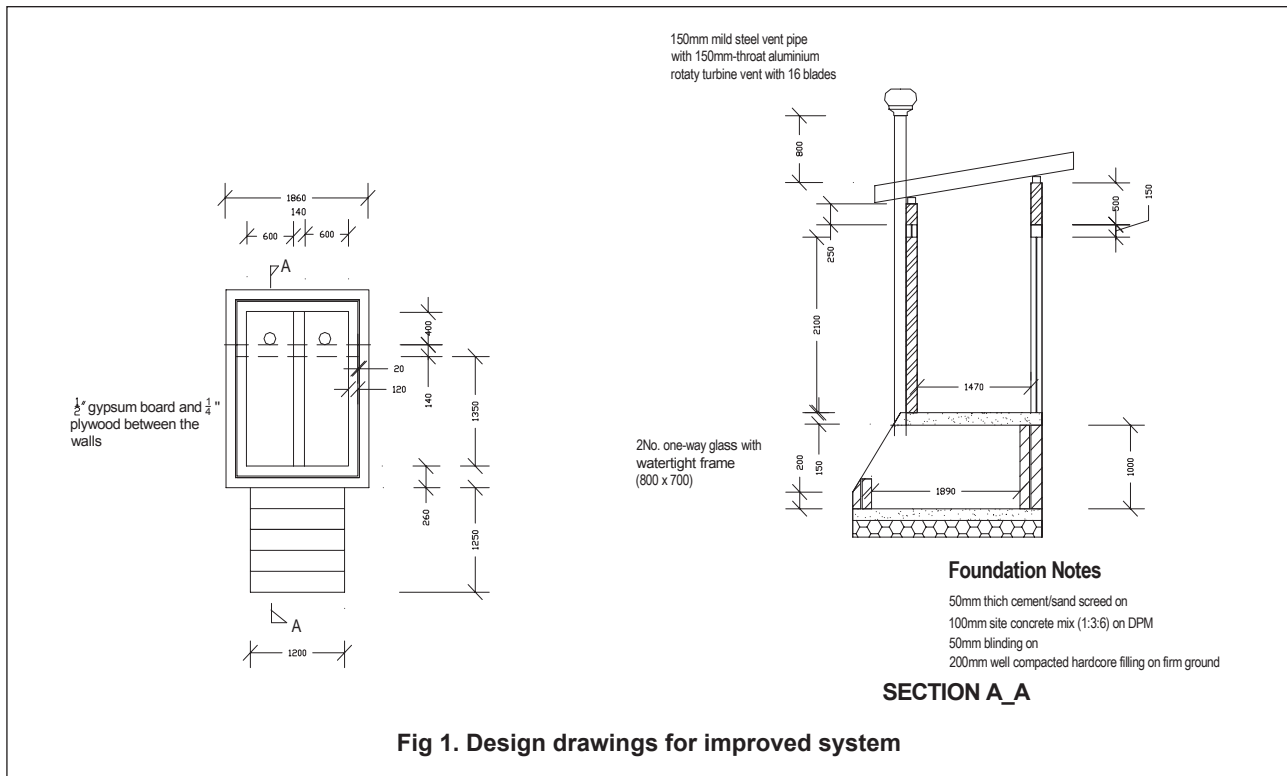

Fig 1. Design drawings for improved system

### Recommendations

- The design should be redone with the temperatures recorded over a period of at least one year, so that there is greater confidence that the system designed can serve adequately even during those seasons when the lowest ventilation rates are achieved.
- The suggested improvements should be incorporated in the current dehydration Ecosan design and a prototype be made to monitor the performance of the improved design in comparison with the existing design.
- The minimum vent pipe should not be less 150mm.
- A black material of a stronger grade should be used for the vent pipe and the pipe should be located on the outside of the Ecosan unit to improve absorptivity and maximise the surface area exposed to the sun.

### References

- Arch-hku-Department of Architecture - University of Hong Kong, Lecture notes on Air Movement and Natural Ventilation. <http://www.arch.hku/teaching/lectures/airvent/sect.03.htm>, created August 2001, accessed 20th March 2004.
- ASHRAE Standards for Adequate Ventilation Rates and Contamination Levels.
- Balthazar Lorenza et al, "Energy Conservation in Construction and Design: Exterior Wall Insulation", 1992, Louisiana, USA.
- Esrey Steven et al, "Ecological Sanitation", 1998, SIDA, Stockholm.
- Esrey Steven et al, "Closing the Loop: Ecological Sanitation for Food Security", 2001, SIDA, Stockholm.

- Habitat for Humanity, "Buildings for the 21st Century: Wall Insulation". 1999. [http://www.energystar.gov/ia/home\\_sealing/WallInsulation-DOE.pdf](http://www.energystar.gov/ia/home_sealing/WallInsulation-DOE.pdf), created February 2000, accessed 11th May 2004.
- Liddament Martin W., "A guide to Energy Efficient Ventilation", 1st edition, 1996, AIVC Publications.
- Lowndes Stephen, "Optimising Natural Ventilation using a Wind Turbine", 2000. <http://www.buildenergy.com/solarchimney.htm>, accessed 21st April 2004.
- Moe Christine and Izurieta Ricardo, "Longitudinal Study of Double Vault urine Diverting Toilets in El Salvador", 2003, proceedings, Second International Symposium on Ecological Sanitation, Lübeck, Germany.
- Parmley Robert et al, "HVAC Field Manual", 1988, MacGraw-Hill, New York, USA.

### Contact address

M.K.Ntabadde  
 Teaching Assistant, Kyambogo University, P.O.Box 1,  
 Kyambogo, Uganda.

C.B. Niwagaba  
 Assistant Lecturer, Makerere University, P.O.Box 7062,  
 Kampala, Uganda.

Dr A.I.Rugumayo  
 Visiting Lecturer, Makerere University, P.O.Box7062,  
 Kampala, Uganda.