



**Pilkington Library**

Author/Filing Title ..... CHIEN T HANG  
.....  
Vol. No. .... Class Mark ..... T

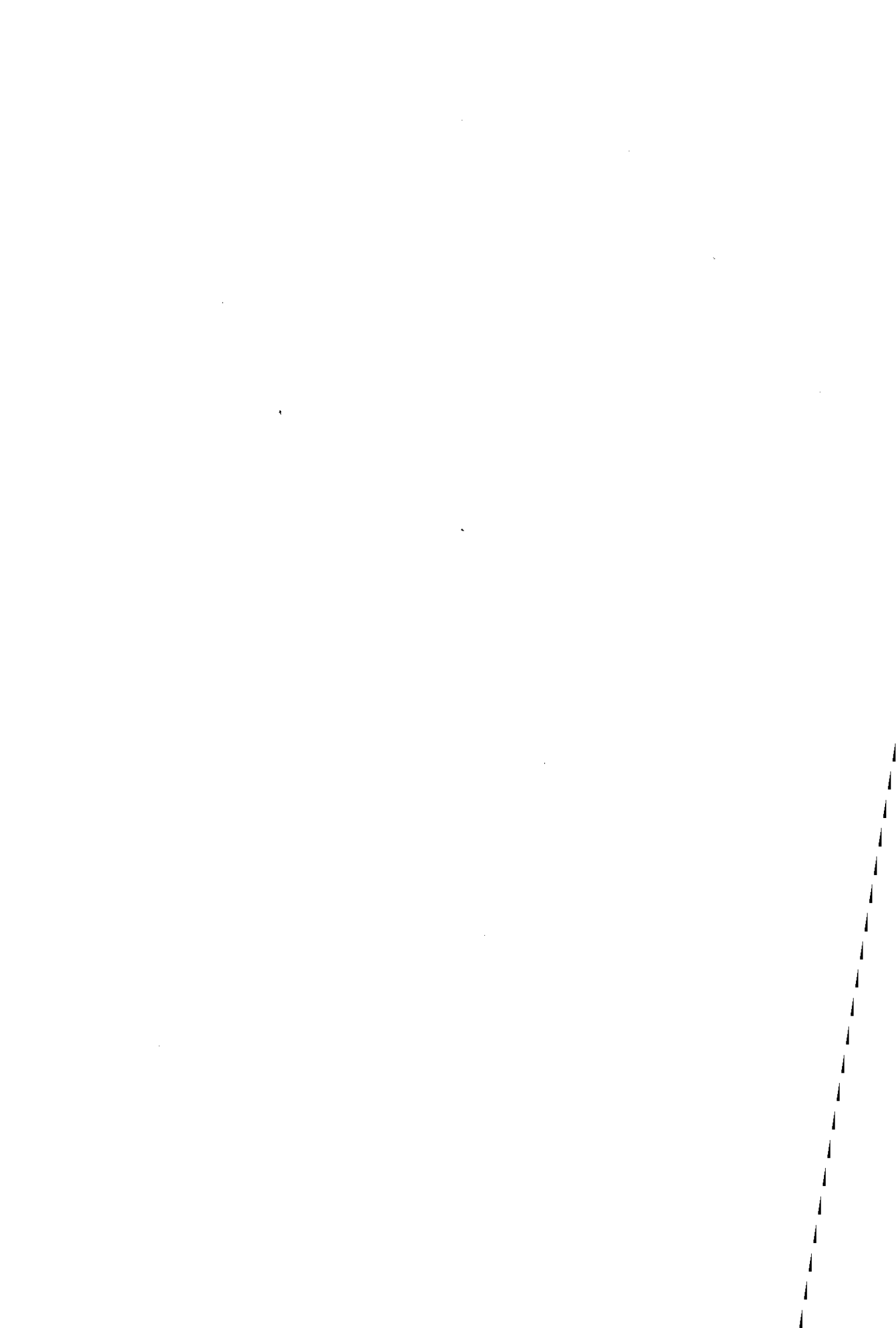
**Please note that fines are charged on ALL  
overdue items.**

- 8 OCT 2000	LOAN COPY	
--------------	-----------	--

**FOR REFERENCE ONLY**

0402220242





# **DETECTION IN SUPERHEATED WATER CHROMATOGRAPHY**

by


Orapin Chienthavorn

A Doctoral Thesis

submitted in partial fulfilment of the  
requirements for the award of the Doctor of Philosophy  
of Loughborough University of Technology

November 1999

Supervisor: Prof. R. M. Smith  
Department of Chemistry

 Loughborough University Library
Date May 00
Class
Acc No. 040222024

M0001736LB

*Dedication*

*To my beloved mom, Nangnoi Chienthavorn.*

## **ACKNOWLEDGEMENTS**

First and foremost, I, very much, appreciated Prof. Roger M. Smith, my “terrific supervisor” for his consistent guidance, encouragement and support in due course throughout my study. I am extremely grateful to the Government of Thailand for financial support and Kasetsart University (Bangkok) for a study leave. I thank the staff from AstraZeneca Pharmaceuticals (Macclesfield), Prof. I. D. Wilson, Mr. B. Wright, Mr. S. Taylor for suggestion and highly valuable advice and the use of their equipment and facilities.

Thank all the following colleagues at Loughborough University for their suggestions and help: Subba Rao, Robert, Simiso, Shikha, Jo, Fabienne, Hussain, Hitesh and Maggi .

Many thanks also go to my special friends in Thailand, USA and Canada, Khun Chana, Lim, Tum, Lek, Pieak, Bill, P’ Somchai, Andrew for their long distance calls and messages, letters, support and help. Your encouragement makes tedious work bearable.

My warmest thanks to my parents, brothers and sisters for an inspiration, eternal support and understanding. Your love and friendship makes my life very pleasant. Thank you all.

## ABSTRACT

Superheated water has been used successfully as an eluent in liquid chromatography and has been coupled to various modes of detection, ultraviolet (UV), fluorescence, and nuclear magnetic resonance spectroscopy (NMR) and mass spectrometry (MS). A number of compounds were examined on poly(styrene-divinylbenzene) (PS-DVB), polybutadiene (PBD), and octadecylsilyl bonded silica (ODS) column with isothermal and temperature programmes. The PS-DVB column was mostly used throughout the project as it was the most stable. Not only pure water could serve as superheated water mobile phase; inorganic buffered water and ion-pairing reagent with a concentration of 1-3 mM of the buffer and reagent were also exploited. It was shown that the pH could be controlled during the separation without salt precipitation and the separations followed a conventional reversed-phase HPLC method. Results from fluorescence detection showed good separation of a series of vitamins, such as pyridoxine, riboflavin, thiamine, and some analgesics. The relationship of riboflavin using the detection was linear and the detection limit was seven times higher than that of a conventional method. Simultaneous separation and identification using superheated water chromatography-NMR was demonstrated. With using a stop flow method, NMR spectra of model drugs, namely barbiturates, paracetamol, caffeine and phenacetin were obtained and the results agreed with reference spectra, confirming a perfect separation. A demonstration to obtain COSY spectrum of salicylamide was also performed. The method was expanded to the coupling of superheated water LC to NMR-MS. Results from the hyphenated detection method showed that deuteration and degradation happened in the superheated water conditions. The methyl group hydrogens of pyrimidine ring of sulfonamide and thiamine were exchanged with deuterium. Thiamine was decomposed to 4-methyl-5-thiazoleethanol and both were deuterated under the conditions.

# CONTENTS

<b>CHAPTER 1</b>	<b>Introduction</b>	<b>1</b>
1.1	Introduction to superheated water	2
1.2	Background of superheated water and superheated water chromatography	3
1.3	Superheated water chromatography	7
1.4	Methods of detection in high temperature liquid chromatography	10
1.4.1	Ultraviolet spectroscopic detection	12
1.4.1.1	Solvent effect	13
1.4.1.2	Temperature effect	15
1.4.1.3	Pressure effect	16
1.4.1.4	Sensitivity of UV detection	16
1.4.2	Fluorescence detection	17
1.4.2.1	Solvent effect	18
1.4.2.2	Temperature effect	21
1.4.2.3	Pressure effect	22
1.4.2.4	Sensitivity of fluorescence detection	22
1.4.2.5	Fluorescence detection in SFC	22
1.4.3	On-line nuclear magnetic resonance (NMR) spectroscopy-liquid chromatography	24
1.4.3.1	Solvent effect	27
1.4.3.2	Temperature effect	29
1.4.3.3	Pressure effect	32
1.4.3.4	Sensitivity of NMR detector	32
1.4.4	Mass spectrometry (MS)	34
1.4.4.1	Solvent, flow rate and pressure	36
1.4.4.2	Sensitivity of MS detector	38
1.4.4.3	SFC-MS	39
1.4.4.4	Electrospray LC-MS	40
1.5	Aim of research	45



<b>CHAPTER 2</b>	<b>Experimental</b>	<b>46</b>
2.1	Chemicals	46
2.1.1	General chemicals	46
2.1.2	Standard chemicals	47
2.2	Instrumentation, Equipment and Materials	48
2.2.1	Superheated water chromatography	48
2.2.2	UV detector	49
2.2.3	Fluorescence detector	49
2.2.4	Nuclear Magnetic Resonance Detector	50
2.2.5	NMR and Mass Spectroscopic detectors	51
2.2.6	Chromatographic Columns	52
2.2.7	Mobile phase	53
2.3	Preparation of standards	53
2.4	Extraction Procedure of kava root sample	54
2.5	Preparation of mobile phase	54
2.5.1	Preparation of buffer pH 3-12	54
2.5.2	Preparation of ion pairing mobile phase	55
2.6	A calculation of $pK_a$ value using retention factor	55
<b>CHAPTER 3</b>	<b>Effect of Additives in the Mobile Phase</b>	<b>58</b>
3.1	Introduction	58
3.2	Unbuffered superheated water	61
3.3	Buffered superheated water	66
3.3.1	Separation of sulfonamides in acid, neutral and basic buffered superheated water	67
3.3.2	$pK_a$ Determinations of some sulfonamides in superheated water conditions	74
3.4	Ion-pair chromatography in superheated water	85
3.5	Summary	89
<b>CHAPTER 4</b>	<b>Fluorescence Detection Method</b>	<b>91</b>
4.1	Introduction	91
4.2	Separation of vitamins	92

- 4.2 Separation of vitamins 92
  - 4.2.1 Separation of riboflavin 92
  - 4.2.2 Separation of thiamine 97
  - 4.2.3 Separation of pyridoxine 100
- 4.3 Separation of aspirin, salicylamide and quinine 102
- 4.4 Summary 106

**CHAPTER 5 Nuclear Magnetic Resonance (NMR) Detection 107**

- 5.1 Deuterium oxide 108
- 5.2 Coupling superheated water chromatography with NMR 111
- 5.3 Application of superheated water chromatography – NMR of analgesic and related drugs (paracetamol, caffeine, and phenacetin) 113
- 5.4 Application of superheated water chromatography – NMR to barbiturates 116
- 5.5 Application of superheated water chromatography – NMR to natural products 120
- 5.6 Application of superheated water chromatography – NMR to riboflavin 130
- 5.7 Summary 133

**CHAPTER 6 Hyphenated Methods of Detection 134**

- 6.1 Coupling superheated water to NMR and mass spectrometer (MS) 134
- 6.2 Application to salicylamide 135
- 6.3 Application to sulfonamide compounds 141
- 6.4 Application to thiamine 155
  - 6.4.1 Separation at 160 °C with buffered superheated deuterium oxide 155
  - 6.4.1 Separation at 190 °C with buffered superheated deuterium oxide 167

6.4.1 Separation at 190 °C with unbuffered superheated deuterium oxide	171
6.5 Summary	176
<b>CHAPTER 7 Conclusion and Future Work</b>	<b>177</b>
<b>References</b>	<b>182</b>
<b>Papers and Presentations</b>	<b>202</b>

---

---

## Chapter 1

---

---

# Introduction

In our planet, water is ubiquitous, covering about 71% of the surface and plays an essential role in climate, the environment and all living things. Terrestrial organisms are largely comprised of water in which nutrients are dissolved and transported around their bodies. Water serves as a main solvent in the world and water can dissolve a variety of compounds, organic and inorganic. In organic chemistry, liquid water is classified as a weak solvent, compared to commonly used solvents, such as methanol, acetonitrile, and dichloromethane, because of its higher polarity. Since the ancient world, people have made use of hot water and steam to extract various drugs, remedies, etc. Attention was drawn to superheated water in the engineering field, which utilised its power to drive motors and mechanical equipment, but the use of superheated water in chemistry has been very rare.

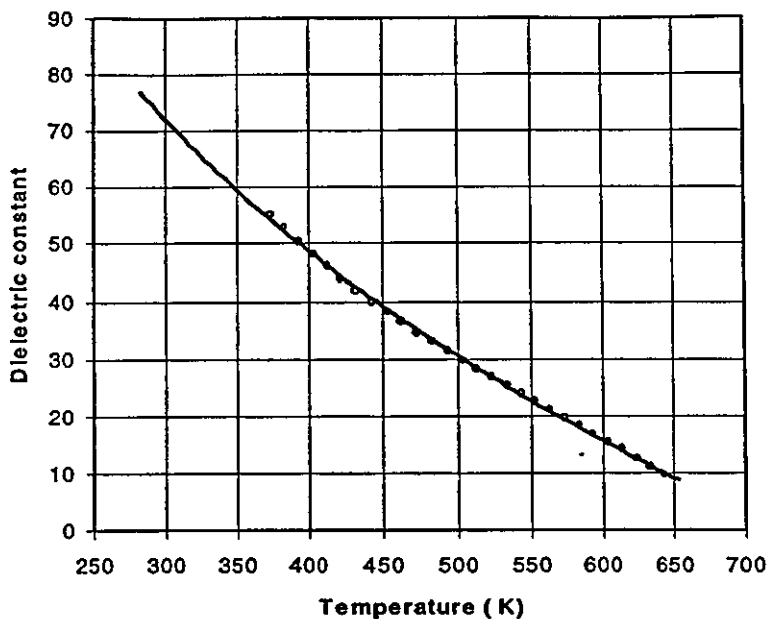
In this study, we will examine the use of water as a clean eluent in chromatography, in particular the range of detection methods that can be employed for superheated water chromatography.

## 1.1 Introduction to superheated water

“Superheated” as a definition [1] means “thermodynamically at a temperature above which a change of state would normally occur (e.g. the change of water from a liquid to a vapour.), without this change having taken place” (usually because a pressure higher than atmospheric has been applied to the system). At elevated temperatures and pressures the water may become supercritical, which is defined as water above the critical temperature ( $T = 374.3\text{ °C}$ ) and pressure ( $P = 221\text{ atm}$ ) [2].

Superheated water throughout this thesis is defined as water under elevated pressure ( $>15\text{ bars}$ ) and temperature ( $>100\text{ °C}$ ). The alternative term “subcritical water” also refers to the state of water as a liquid between the critical point and boiling point. Under these conditions, the polarity of water decreases as the temperature increases (Figure 1.1) [3]. Therefore, by raising the temperature to  $210\text{ °C}$  ( $\delta = 32.93$ ) water can imitate some organic solvents, such as methanol, whose dielectric constant is 32.7 at  $20\text{ °C}$ . The dielectric constant of water at  $180\text{ °C}$  ( $\delta = 37.12$ ) is equivalent to that of acetonitrile ( $\delta = 37.5$ ). However, the dielectric constant alone cannot determine the eluting power of the solvent or of the eluent in reversed-phase separations. Factors, such as solvent strength, acid-base properties, etc. must be also counted. Among those solvents, superheated water is considered to be the weakest [4].

In chemistry, an ideal solvent possess qualities, such as low cost, low toxicity, high solvent strength, non-flammable, high auto-ignition temperature ( $\text{CS}_2$  has an auto-ignition temperature at  $100\text{ °C}$  [5]). Among those qualities, though acetonitrile is inexpensive and has high solvent strength, it is considered to be inflammable, toxic, and hazardous. Methanol has similar qualities, except higher toxicity [6].



**Figure 1.1** *The dielectric constant of water as a function of the absolute temperature [3].*

## 1.2 Background of superheated water and superheated water chromatography

Nowadays, superheated water or subcritical water is very well known in the physics and engineering fields. An internet search readily found valuable information, such as general steam data which contains a range of factors, e.g. specific volume, enthalpy of saturated steam in a range of 32-212 °F, viscosity, and total heat of steam for a generating plant [7]. Water near its critical point has also been used for many purposes in organic chemical reactions [8]. For example, it has served as a reaction medium, a reactant or a catalyst in alkylation [9], hydrolysis [10] and oxidation [11].

In environmental science, superheated water can occur naturally, in a typical hydrothermal vent system when cold sea water is heated by a body of magma in the ocean depths [12-13]. Supercritical water has been utilised safely in

oxidation technology as an alternative to incinerators for the disposal of hazardous waste and sludge for more than 15 years [14]. However, corrosion of such disposal units by acidic gases and salts has prevented the widespread commercial or military adoption of such an approach.

In the past few decades, supercritical fluids have been utilised in extraction technology. Most of publications used carbon dioxide (CO<sub>2</sub>) as a supercritical fluid (SF) with and without modifiers (e.g. methanol or CHCl<sub>3</sub>) and were applied in the fields of environmental, pharmaceutical, polymer, natural product, and food science [15-16]. Various sophisticated SFE instruments were launched, for example, 7680T/SFE (Hewlett-Packard, Wilmington, DE, USA), SFE-400 (Supelco, Bellefonte, PA, USA), etc. It was noticed that all of these instruments were designed purposely for the CO<sub>2</sub> fluid mobile phase or fluids with low critical temperatures ( $T_c$ ), such as Xe ( $T_c = 17\text{ }^\circ\text{C}$ ), ethane ( $T_c = 32.3\text{ }^\circ\text{C}$ ), N<sub>2</sub>O ( $T_c = 36.5\text{ }^\circ\text{C}$ ), propane ( $T_c = 96.7\text{ }^\circ\text{C}$ ), because the maximum allowable temperature is 150-200 °C. Temperatures between 100-250 °C, which normally needed for superheated water, hence, cannot be obtained with these instruments.

Recently, the use of supercritical and subcritical water for chemical extraction has become more interesting. Subcritical water has been used to extract organic compounds, such as organic pollutants [17-18] and hydrocarbons [19-20] from solid matrices including soil and waste.

Temperature has a primary effect on extraction efficiency [17, 20-22]. A study by Hawthorne *et al.* [17] showed that with an increase in the extraction temperature, the number of extracted compounds range from polar organics, e.g. chlorophenol (50 °C), to nonpolar organics (> C<sub>20</sub> alkanes) (400 °C). Crescenzi *et al.* [21] evaluated the feasibility of using hot water (50, 90 and 120 °C) to extract herbicide residues in soil and also found that with increasing extraction temperature the less polar herbicides were removed.

Even at a lower temperature ( $T < 100\text{ }^{\circ}\text{C}$ ), the temperature still has a great impact on the extraction efficiency of fungicides from agricultural products [22]. Increasing temperature also increased the percentage removal of organic components in solid matrices [23-24], soil and waste [20]. Johnson *et al.* [20] studied absorption equilibria of organic carbon on soil samples using superheated water and steam at 150-250  $^{\circ}\text{C}$ . They described that liquid water removed more carbon from soil than steam, because of many polar functional groups of the humic organic matter that readily associate with water.

Increasing temperature of subcritical water also increases the solubilities of scarcely soluble organic compounds [25-26], as well as higher molecular weight compounds [27]. Miller *et al.* [25-26] revealed that the solubilities of PAH and pesticides increased 4-5 orders of magnitude when raising subcritical water from 298 K to 498 K. A study by the same research group show that at high temperature the percentage extraction of chlorinated biphenyls was consistent with their solubilities in water at ambient conditions which depend on their molecular weights [17, 19, 27-28]. For example, less chlorinated biphenyls are more water-soluble at ambient temperature, at 200  $^{\circ}\text{C}$  they were easier to extract than the highly chlorinated biphenyls [27]. High molecular weight alkanes also fall into this category. The higher molecular weight of alkanes, the less the percentage extraction by water [19]. High molecular weight alkanes ( $> \text{C}_{20}$ ), which are easily extracted using supercritical  $\text{CO}_2$ , at 300  $^{\circ}\text{C}$  could not be extracted by water. Nevertheless, those alkanes could be effectively and quantitatively removed by steam extraction (250  $^{\circ}\text{C}$  and 5 atm).

In contrast to effect of temperature on solubility, a large increase in pressure (40 to 400 bars) lowered the solubilities, but had much smaller effect than temperature and caused only a very small change in PAH solubilities [25].



Subcritical water extraction was compared to conventional extraction methods, such as Soxhlet extraction [21, 28], ultrasonic extraction [21] and steam distillation. Again, the study by Hawthorne *et al.* [28] showed that the percentage removal of PAHs and aromatic amines from soils from rail-road beds and industrial sites using a subcritical water extraction (250 °C, 15 and 60 min) on-line with solid-phase microextraction were in a good agreement with a 24 hr conventional Soxhlet extraction with dichloromethane. Whereas, Crescenzi *et al.* [21] found that subcritical water extraction is more efficient than Soxhlet extraction for non-acidic herbicides and more than ultrasonic extraction for more polar acidic herbicides. Superheated water extraction of aroma compounds from rosemary plants gave higher yields than steam distillation, as reported by Basile *et al.* [29]. By using water between 125 and 175 °C, rapid extract of oxygenated fragrance and flavour compounds could be achieved while leaving behind monoterpenes, high hydrocarbons and lipids.

Elution of organic solutes absorbed on glass beads, Florisil, alumina, C18 and XAD-4 column by water at 50-250 °C was demonstrated by Yang *et al.* [23, 27]. By using the matrix effect, they described that water at low temperatures (more polar) can elute the solutes from glass bead, Florisil and alumina because it can break inert or dipole interactions between the solutes and sorbents. While high temperature water is required to elute the same compounds from C18 and XAD-4 columns because more energy is needed to break the van der Waals and  $\pi$ -electron interactions between the solutes and C18 sorbent [27]. When coupling a sorbent trap (silica-bonded C18 column) on-line to RP-HPLC after subcritical water extraction of aromatics and PAHs [23], the chromatogram showed no difference in the peak shape of all components, compare to a normal HPLC calibration without the extraction. Jimenez-Carmona *et al.* [24] found that the leaching kinetics of fluorescent compounds from solid matrices by subcritical water were accelerated when using silica instead of diatomaceous earth, due to the polarities of the sorbents.

When using subcritical water as an extraction technique, some problems may occur, for example, corrosion and damage to the packing material by hot water [18], a deposition of extracted species at high temperatures (>100 °C) after the extraction cell [23], as well as reactions at high temperature. Hageman *et al.* [29] found that anthracence converted to anthraquinone at 250 °C, despite of the initial removal of dissolved oxygen from the system. They showed a real concern of a possible potential degradation when using high temperature water extraction. The catalytic hydrolysis of phenylurea herbicide on silica at high temperature (>90 °C) was also reported by Crescenzi *et al.* [21].

Modifying the water extractant by introducing additives is also possible. Additives, such as 20% acetone or salts, were added to water for the extraction of herbicide residues from soil but no significant improvement was found in the recovery of the analytes [21].

### 1.3 Superheated water chromatography

In chromatography, superheated water has been employed as a mobile phase, allowing it to imitate a mixture of organic solvent and water in RP-HPLC [30-32, 34-35]. Smith and Burgess [30-31] studied the separation of polar to less polar analytes using superheated water at the temperature up to 210 °C on PRLP-S (or PS-DVB, poly(styrene-divinylbenzene)), octadecylsilyl bonded silica (ODS), porous graphitic carbon (PGC) and polybutadiene (PBD) - zirconia columns. As the temperature was increased, the retention of organic compounds decreased but the efficiency increased. They also found that higher temperatures, at which water behaved like an acetonitrile-water mixture, were needed to elute more hydrophobic compounds and the retention followed conventional reversed-phase LC. A plot of  $1/T$  against retention factor was non-linear, suggesting that not only a conventional  $\Delta H$  effect but dielectric constant also dominated the retention [30]. Analytes were

eluted from silica ODS column with lower temperature than from PS-DVB column, this agreed with a conventional RP-mode that retention is weaker when using ODS than PS-DVB column with the same eluent [31]. Prolonged use of ODS column decreased the retention because of the column instability but no hydrolysis or degradation of the analytes were observed.

Miller and Hawthorne [32] demonstrated the use of subcritical water chromatography with a flame ionisation detector (FID) on a PRP-1 (PS-DVB) column. Increasing temperature improved the peak shape and decreased the retention time of all components. A temperature gradient was reported to have similar effect on retention as a mixture of acetonitrile (or methanol) – water. By programming from 120 to 150 °C, the polarity of water was reduced and the separation of seven alcohols, ranging from relatively more polar (methanol) to less polar (butanol), was achieved. Quantitative determination of alcohols in beverages was also demonstrated. No degradation was observed on the column.

Yang *et al.* [33] investigated the retention behaviour of some aromatic compounds in a subcritical water separation. By using water at 200 °C, the separations of chlorinated phenol and anilines were similar to those obtained by 68-69% organic solvent-water mixtures. They found the retentions of both polar and non-polar analytes were shortest on alumina, moderate on silica-bonded C18, and longest on PRP-1 (PS-DVB) column. Good thermal stability of the commercial RP-columns and UV detector were observed in this work.

Haddad *et al.* [34] used pure hot water with a temperature gradient up to 65 °C as a pure mobile phase for the separation of nucleosides and their bases on an ODS column. They confirmed damage to the ODS column at high temperature (> 70 °C) but if the separation was performed at below 70 °C, the efficiency of the column was retained without any serious effects on the column. They also described thermal effects on the separation. Elevating the temperature enhanced the thermal mobility of the bonded-phase and then

reduced the hydrophobicity between the stationary phase and analytes, therefore, the distribution of analytes to mobile phase increased. In spite of the use of unbuffered water, no significant changes in the retention of ionised species were observed, perhaps because of the narrow range of temperature change.

Pawlowski and Poole [35] studied the influence of temperature between 75-180 °C on the properties of pressurised water mobile phase on PRLP-S 100 column. In their system, 1% acetonitrile was added to pure water to maintain the peak shape of all solutes at low temperature and it had little effect on solvation properties of water. A comparison with different RP-mobile phase systems showed that the elution strength of 1% acetonitrile-water at 180 °C corresponded to 15-25% acetonitrile-water, 25-35% propanol-water, or 50-60% methanol-water. However, a decrease in retention by increasing temperature of 1% acetonitrile-water is different from that by increasing organic solvent composition in those three mobile phases. It was also noted that temperature programming with water as a mobile phase is less powerful than using a solvent composition gradient. They confirmed that water at 75-180 °C, compared with acetonitrile and methanol, possess a relatively weak eluting power in RP-HPLC.

As superheated water can damage chromatographic columns, Burgess [36] compared the stability of a number of columns including octadecylsilyl bonded silica (ODS), porous graphitic carbon (PGC) and polybutadiene (PBD) - zirconia column. The polymeric, polystyrene divinyl benzene or PS-DVB, column was found to be the most stable, whereas ODS silica based columns were the least stable due to the dissolution of silica base material at high temperature. Porous graphitic carbon (PGC) which is made of an inert graphite crystallite material was more promising, as it was inert and therefore could tolerate acidic and alkaline eluents in the whole pH range (1-14). However, it tended to give a poor separation, as shown by long tailing peaks, although these could be improved by operating at higher temperatures.

Because of the dissolution of the silica base at high temperatures, a trial was performed on a PBD zirconia based column. It was believed to have good mechanical strength and similar physical properties to a silica-based column. With this column, a good separation with less retentivity compared to PS-DVB column was obtained.

For controlling the temperature of the column, most approaches have made use of typical GC ovens [30-32, 35-36], as they could be programmed isothermally or gradient temperature. A different type of thermostat bath for controlling the temperature was designed by Liu *et al.* [37]. They utilised a long cylinder metal thermotank (32 cm x 28 mm id. carbon-steel tube with one end sealed) packed with aluminium chips for rapid-heating and temperature distribution, then placed in a thermostat oven. This design seemed to work well to rapidly raise temperature in a range 20-210 °C but it needed a long equilibration time (more than 30 min) and seemed not be able to cool temperature down quickly.

#### 1.4 Methods of detection in high temperature liquid chromatography

Since superheated water chromatography is similar to conventional reversed-phase chromatography at high temperature, it is of interest to consider if detection methods that are used for conventional HPLC could also be coupled on-line to the superheated water system. However, there was a concern about the feasibility of the coupling and whether the detector performance may be affected by the conditions of superheated water and the sensitivity differences. A number of those detection methods, such as UV, fluorescence, NMR and MS will be described, particularly the effects of high temperature, pressure, solvent, difficulties and problems in on-line coupling the detectors to a liquid chromatograph. Some detector characteristics, such as sensitivity, selectivity, etc., will also be given.

**Figures of merit of detectors [38-39]****Sensitivity**

The sensitivity of a detection method is defined as the slope of an output signal response to the analyte concentration. A high slope represents a high sensitivity, which generally suggests an efficient detector.

**Detection limit**

Detection limit is usually defined as a minimum concentration or mass of an analyte that gives a signal significantly different from the background noise (or blank signal).

If  $x$  = the analyte signal and  $x_B$  = the background signal, the signal at the detection limit can be given by the equation below.

$$x - x_B = 3 SD_B$$

Where  $SD_B$  = a standard deviation of the background signal. A detection limit of a detector depends on the sensitivity and noise of the detector. For example, if the sensitivities of two detectors are identical, the detector with a lower noise allows a lower detection limit.

**Minimum detectable quantity (MDQ)**

Minimum detectable quantity is defined by a quantity of sample that gives peak height three times over background noise. In practice for an integrator, it requires a signal (peak height) to noise ratio = 3.

**Selectivity**

Selectivity of a detector is the ability of a detector to discriminate between analyte species of different types or compositions.

**Noise**

Noise is the baseline signal fluctuation which occurs from electronic parts of instrument, for instance a weak UV source, a long-time used lamp or dust on

optical surface, a degraded optical coating, etc. It can arise from chemical responses in the separation system or the immediate environment.

Drift is a type of noise of which slope is measured the absorption over a period of one hour (absorbance unit per hour).

### ***Dynamic range and linear dynamic range***

On a calibration curve, detector response changes with a concentration or mass of analyte. The entire range of measured concentration or mass is called a dynamic range that is possibly either linear or non-linear response. A linear dynamic range is usually a part of the whole range that gives a linear detector response to mass or concentration. The minimum point of the range is the detection limit (LOQ) and the maximum point is the highest mass at which the response is equal to 5% deviation from the intersection of this linear line [40].

#### **1.4.1 Ultraviolet spectroscopic detection**

Detection by ultraviolet absorption spectroscopy is the most commonly used method in liquid chromatography (both HPLC and SFC). The popularity of this method is due to the ability of most organic compounds to absorb UV, the simplicity of instrumentation, low cost for purchase and maintenance of the instrument, as well as being a non-destructive detector.

Ultraviolet radiation is usually absorbed by a compound containing one or more covalent unsaturated functional groups, which are called "chromophores". When irradiated, these compounds absorb the light and change the molecular transition. Polyaromatic hydrocarbons are examples of highly polyconjugated systems that strongly absorb UV light.

Saturated hydrocarbons with only single bonds absorb the energy of a transition of  $\sigma \rightarrow \sigma^*$  type which occurs at a very short wavelength in the vacuum ultraviolet. Hence, they do not present absorption in the UV and visible region.

The equation of the absorption of the light by the compounds is given by Beer-Lambert's law:

$$\log \frac{I_0}{I} = \log \frac{1}{T} = A = \epsilon bc \quad \dots\dots\dots(1)$$

Where  $I_0$  = the incident beam intensity,  $I$  = the transmitted beam intensity,  $T$  = the transmittance,  $A$  = the absorbance,  $\epsilon$  = molar absorptivity ( $L \text{ mol}^{-1} \text{ cm}^{-1}$ ),  $b$  = path length (cm) and  $c$  = concentration (Molar).

#### 1.4.1.1 Solvent effect

An important consideration in using UV absorption detector is that the mobile phase must be transparent at the wavelength at which the detector is operated.

When UV absorbed analytes are dissolved in a solvent, the electronic ground state and excitation state of the compounds can be stabilised by the polarity of the solvent. This results in a phenomenon of the solvent shift of the  $n \rightarrow \pi^*$  transition of polar compounds, such as carbonyl groups dissolved in polar solvent, to lower energy. However, the effect on  $\lambda_{\text{max}}$  and  $\epsilon_{\text{max}}$  for a series of hydrocarbon solvents is slight and can be ignored.

More important criteria in using the HPLC solvent is the UV absorption of the solvent itself at low UV wavelengths. The solvents for RP-HPLC therefore have a UV cut-off wavelength (defined as "The wavelength at which the



absorbance of the solvent versus air in 1-cm matching cells is equal to unity.” [41]). Practically, the cut-off occurs when the transmitted beam intensity is less than 10% of the incident beam intensity. Beyond this wavelength, it is not recommended to use the solvent as it gives high background absorbance. Acetonitrile has a UV cut-off at <190 nm, which is a very low wavelength but it is hard to purify to this quality and practically affordable grades usually cut off at higher wavelengths 205 or 230 nm. Methanol has a wavelength UV cut-off at 205 nm. In fact, the absorption of methanol is long tailing, at 215 nm methanol has an absorbance of more than 0.3. On working with gradient elution using a mobile phase containing methanol, care should be taken, since it causes baseline drift, which is predominantly caused by methanol composition changes. Consequently, this leads to a decrease in overall analytical accuracy and precision. Tetrahydrofuran (THF) possess a spectroscopic quality like methanol but has a higher UV cut-off (<212 nm) and its spectrum is strongly shouldered and long tailing. This make THF less useful when working at a longer wavelength, such as 250 nm, with a high content. Supercritical carbon dioxide is transparent even at 190 nm and gives no absorption along a range of UV.

In general, when a mobile phase comprising an organic modifier, such as acetonitrile, is mixed with water or buffers it can cause bubbles [42], leading to a cloudy solution which behaves as if it absorbs the UV light, even though the measurement is performed at a wavelength more than the UV cut-off. The mixed mobile phase, therefore, must be degassed before use.

Water has been utilised in almost all separations by RP-HPLC. The quality of HPLC grade water must be pH 7, very low UV absorption, very low content of inorganic and organic contaminants, and contain no bacteria. When a sealed bottle of water is opened, microorganisms starts to multiply unless the water is mixed with more than 10% of organic modifier or is at very low pH (pH < 4). Bacteria can multiply in aqueous systems, for example in the pump, mobile phase reservoir, filter and column frits. Hence, special care must be taken

when dealing with low content water mobile phase.

Types of buffer are also important. Buffers, such as formate, acetate and carbonate, can absorb UV light, hence, they are not very useful when operated at short wavelengths [43]. In some circumstances, impurities in ion-pair reagents can be a source of UV-absorbing contaminants.

#### **1.4.1.2 Temperature effect**

For detection by UV spectroscopy, the detection compartment of a typical UV detector is not temperature-controlled. This is because temperature changes can only induce slight effects in the molar absorptivity ( $\epsilon_{\max}$ ) of a compound [44]. However, when the UV detector is connected to a chromatographic system, the temperature should be controlled. Temperature of the mobile phase, entering the flow cell is often different from temperature of the flow cell in a UV absorbance compartment and a temperature alteration can cause a refractive index change [45]. In a UV compartment, when the incident beam is entering the flow cell, it must pass a quartz window which possesses two interfaces, air-quartz and quartz-liquid. The light passing through quartz-liquid interface is a function of the refractive index difference between two media [45]. As the refractive index difference increases, the light is more scattered and the light reaching the detector changes, thus altering the intensity. This phenomenon produces the same effect as an absorption by a compound and then increases the noise. Refractive index is not only a characteristic of each compound but is a function of temperature, and changes by  $10^{-3}$  per degree Celsius. Hence, in the UV compartment, a heat exchanger must be placed prior to or clamped around the flow cell for thermal equilibration [46], particularly when the column oven is operated above ambient temperature. Those designs include wrapping the flow cell compartment with a long inlet narrow tubing, wrapping the inlet tubing around an aluminium block or embedding an inlet tubing coil in a lead block. However, an increase in extended tubing can cause extra band broadening.

### **1.4.1.3 Pressure effect**

As seen from Beer-Lambert law in equation (1),  $A = \epsilon bc$ , the pressure does not predominantly affect UV absorption. In HPLC, the high pressure flow cell is, however, designed to eliminate air bubbles which can cause an unstable background noise in mobile phase by increasing the pressure on the flow cell to a sufficient level to suppress the bubbles [45].

In SFC, pressure does not directly affect the absorption, but the density of liquid containing in the flow cell. The change of mobile phase density of the fluid in the flow cell can cause a fluctuation of refractive index and this contributes to an unstable baseline. This effect arises in SFC more than conventional HPLC because the fluid density change in SFC is more than HPLC. The density change is directly related to pressure and inversely reciprocal to temperature. Density programming in SFC is thereby achieved by positive pressure programming and/or negative temperature programming. With pure CO<sub>2</sub> mobile phase density programming in SFC can result a baseline drift [47-48]. To solve the problem a programmed baseline by a detector is applied to compensate the shift or adding an organic modifier to CO<sub>2</sub> may help a stabilisation of the baseline signal [47].

### **1.4.1.4 Sensitivity of UV detection**

UV detection method is moderately high sensitive [47], hence, it can be used for the analysis of trace components with chromophores. A relatively wide linear dynamic range enables it to be used for both qualitative and quantitative analysis. Due to its performance criteria, for example the selectivity and the simplicity of the method, the inexpensive cost and maintenance, etc, it enables the use of this technique to be the most popular among LC and SFC detection [39]. A comparison between UV and other method of detection in LC is given in Table 1.2.

### 1.4.2 Fluorescence detection

Use of the fluorescence method of detection in liquid chromatography (both HPLC and SFC) has increased during the last few decades. This is attributed to three aspects of fluorescence: selectivity, specificity, and sensitivity. Selectivity and specificity are realised in that they are related to compounds of which molecules or species give fluorescence (or so-called "contain fluorophore") at different excitation and emission wavelengths.

Fluorescence has many aspects in applications in both organic and inorganic compounds [49]. In general, a native fluorescent molecule has a characteristic of containing an extensive  $\pi$  electron system with rigid molecules, such as aromatics, highly conjugated molecules, polynuclear aromatic compounds, etc. However, not all rigid molecules give fluorescence. A number of applications of fluorescence to inorganic analysis involve metals, non-metals and chelates of metal ions. Applications are also to qualitative and quantitative analysis of organics, for instance, proteins and amino acids, polynuclear aromatic hydrocarbons, vitamins, drugs, steroids, and many chemicals in agriculture and the environment.

An effective and useful technique to determine a species that does not give fluorescence, is to make a fluorescent derivative (see section 1.4.2.4). Various derivatising agents are commercially available [50-51]. Some of these fluorescence derivatives are rather stable at high temperature, for instance dansyl derivatives.

The reaction of those derivatising agents with analytes is normally rapid, complete and selective for a specific functional group. Some factors that have to be considered, however, are the stability of the derivatives to hydrolysis, solvolysis, and thermal decomposition. To detect non-fluorescence compounds in HPLC, derivatisation is performed into two approaches: pre-column and post-column derivatisation. The pre-column mode is preferable

since it lessens band broadening and sample loss during dilution as in the post-column procedure.

A relationship between fluorescence intensity and the concentration of sample can be described using an equation, which was derived from the Beer-Lambert law as follows:

$$I_f \cong 2.303 I_0 \phi_f \epsilon b c \quad \dots\dots\dots(1)$$

Where  $I_f$  = the intensity of fluorescence,  $I_0$  = the intensity of incident light beam,  $\phi_f$  = quantum yield which is the fraction of photoexcited molecule to lose their excess energy via the fluorescence mechanism,  $\epsilon$  = molar absorptivity ( $l \text{ mol}^{-1} \text{ cm}^{-1}$ ),  $b$  = path length (cm), and  $c$  = the molar concentration.

From the equation, it seems that the relationship between fluorescence intensity and concentration is linear over a long range, but in practice, at very low concentrations it shows a deviation which may be caused by a breakdown in mathematical assumptions [52]. Not only the compound itself can result the effect of fluorescence, environmental effects such as solvent, oxygen quenching, pH, temperature, inner filter effect, can contribute to a dramatic decrease in fluorescence intensity [53].

#### **1.4.2.1 Solvent effect**

Fluorescence intensity and wavelength often vary with the solvent. Several factors involving the solvent, such as pH, temperature, viscosity, solvent polarity and quenching, can affect fluorescence [54].

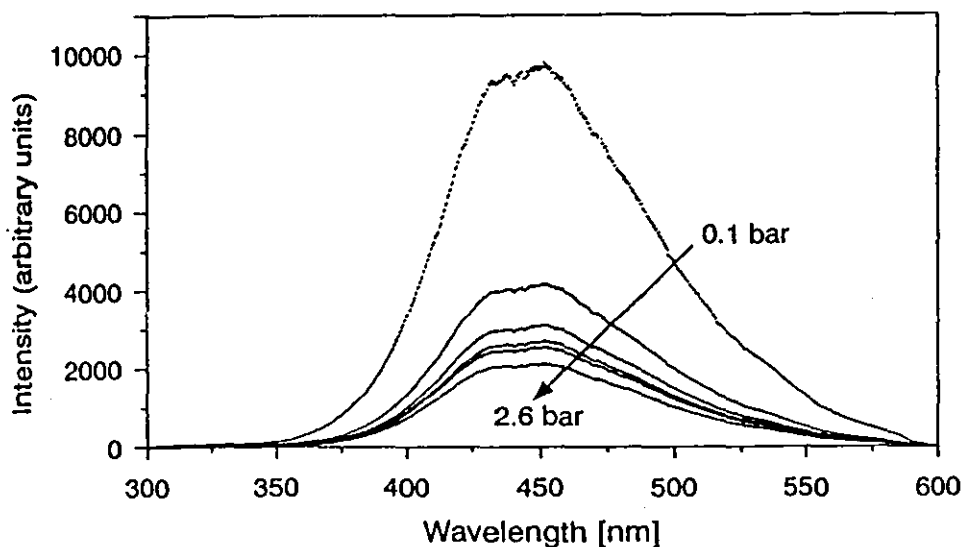
Some fluorescence compounds contains ionisable groups. Changing in the pH of a system affects the fluorescence intensity to compounds whose ionisation are in the range of pH change [38]. For example, most barbiturates fluoresce in 0.1 M base, but not in acidic media [54]. Phenol gives

fluorescence at pH 7 but at pH 12 it is converted to non-fluorescent species. Aniline fluoresces at pH 7 and 12 but when protonated at pH 2, it gives no fluorescence [38]. This can be explained by the neutral form and cationic form of aniline. In acidic solution, the nitrogen atom of aniline is protonated and then give a similar resonance form as benzene, it therefore fluoresces only in UV region. Whereas in neutral and basic solution, it generates three resonance forms, resulting a more stable excited singlet state and a longer wavelength fluorescence emission.

When most polar aromatic molecules dissolve in a polar solvent, both absorption and fluorescence spectra shift to a lower energy wavelength, called "red shift". This is a result of a stabilisation of the more polar excited state than the ground state of  $\pi \rightarrow \pi^*$  singlet state and a minimisation energy of a solute/solvent system [43, 53].

Quenching occurs by collision between fluorescence molecule and the quenching species, giving a reduction in fluorescence intensity. If the solvent molecule contains unpaired electrons or heavy atoms (especially the heavy halogens), these can act as efficient quenching agents [38, 55]. The best-known quenching compound is molecular oxygen, which is a paramagnetic species presented in most solutions.

Molecular oxygen can quench excitation singlet and triplet states of many molecules, such as aromatic hydrocarbons. It can be a major source of error in fluorescence measurement but fortunately it is reversible in many cases. Oxidation of the solute can also cause "oxygen quenching". Removal of oxygen therefore is needed by purging with a more inert gas, i.e. nitrogen, argon, etc, but in a system which is highly sensitive to oxygen, a more complicated degassing system is needed [53]. Figure 1.2 shows the fluorescence of fluoranthene quenching by oxygen [56].



**Figure 1.2** Fluorescence spectra of vapour-phase fluoranthene. On increasing the oxygen pressure, the intensity is reduced [56].

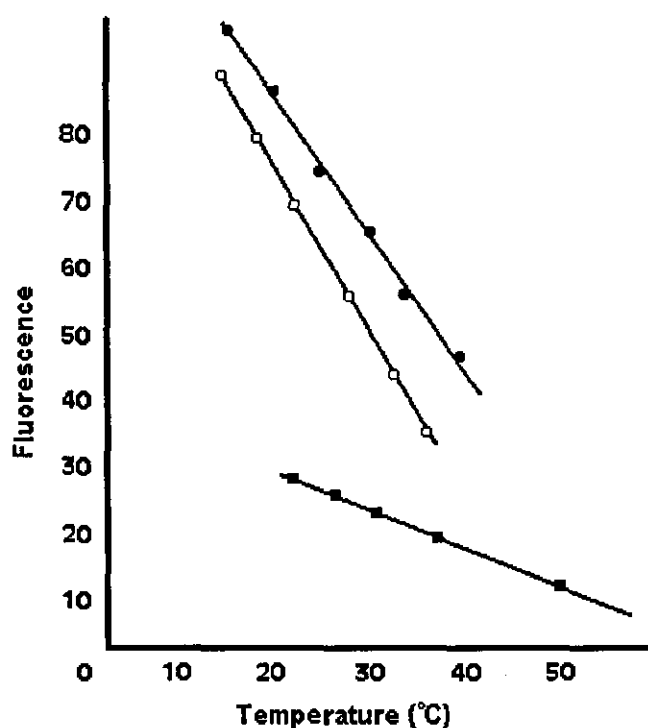
In many circumstances, water has a great effect on quenching fluorescence intensity [57], for example dansyl-tryptophan which gives a strong fluorescence intensity when dissolved in ethanol but gives a much weaker signal in water as shown in the Table 1.1. This is because the ionised dansyl-tryptophan does not fluoresce.

**Table 1.1** Fluorescence data for dansyl DL-tryptophan at a concentration of  $10^{-6}$  M. [57].

<b>Solvent dielectric constant, <math>D</math></b>	<b>Solvent</b>	<b>Quantum yield</b>	<b>Emission <math>\lambda_{max}</math>, <math>m\mu</math></b>
78.5	Water	0.068	578
31.2	Methanol	0.37	533
25.8	Ethanol	0.50	529
21.5	Acetone	0.35	513
5.14	Chloroform	0.41	508

### 1.4.2.2 Temperature effect

Many fluorescence compounds are very thermally sensitive, for example a change in temperature from 15-30 °C affects the fluorescence intensity of some compounds by 1-5% per degree C (Figure 1.3) [53]. Usually fluorescence intensity is inversely proportional to temperature, which is due to an increase in internal and external conversion and intersystem crossing to the triplet state [43]. Besides, high temperatures cause a decrease in viscosity, resulting an increase in collisional quenching in the media and thus a decrease in fluorescence intensity [52, 58]. An increase in temperature can also cause a "red shift" of the emission wavelength [43].



**Figure 1.3** Variation of the fluorescence intensity of several compounds as a function of temperature. All compounds were dissolved in 0.1 M phosphate buffer, pH 7.0 except quinine. ● Tryptophan or indoleacetic acid, ○ indoleacetic acid in buffer saturated with benzene, ■ quinine in 0.1 N sulphuric acid.



### **1.4.2.3 Pressure effect**

Fluorescence detection in HPLC has not been reported to be significantly affected by pressure. Only a few papers have been published using the fluorescence detection method in SFC [59-64] where higher pressures are used but no changes with pressure have been reported.

### **1.4.2.4 Sensitivity of fluorescence detection**

Although, the fluorescence detector is not so widely applicable as the UV detector but it is several orders of magnitude much more sensitive than UV [65]. A derivatisation method can be used when the analyte is not fluorescent [50]. This method has two practical techniques, pre-column and post-column derivatisation. If the analyte has completely reacted with a fluorescence derivatising agent before injection onto the column, it is called "pre-column" derivatisation. Less satisfactory separation on the column may come from modifying the chemical properties of the analyte. This problem does not occur in post-column technique where an excess of derivatising agent is injected into the eluate [45]. However, post-column derivatisation process can cause band broadening and sample loss due to adsorption and dilution effects.

### **1.4.2.5 Fluorescence detection in SFC**

Only a very few papers [59-64] have described the use of fluorescence detectors in SFC. This is mainly due to lack of a commercial fluorescence detectors [62]. However, the research concerning SFC-fluorescence was mostly applied to capillary column SFC. It was found that the sensitivity of the detector would be better, if the supercritical fluid was allowed to be in a liquid state before entering the detector because light is more collimated. This is because of the increased refractive index of the liquid and band compression that occurred from returning from supercritical fluid to liquid state. In addition,

the detector does not have to be heated to the same supercritical fluid temperature as the column.

Recently Grayeski *et al.* [62] developed a post-restrictor interface for SFC, allowing the use of conventional LC detectors for packed-column SFC. With their "sheathing flow interface" design, the detection limit of the fluorescence detector was much improved and a wide range of pressure could be used for separation. They extended the application of the interface to solution based chemiluminescence detection, giving a detection limit of perylene sample separated on a packed cyano column much lower than determined by fluorescence [63]. Fjeldsted and Lee [60-61] analysed carbon black extracts by capillary SFC and detected naphthalene and pyrene by fluorescence detection.

In preliminary studies in the present work of SFC, the use of a two stage pressure reduction was examined [64] and the sensitivity of propranolol detected by fluorescence detector was comparable to that obtained from HPLC with fluorescence detection.

### **Comparison of UV and Fluorescence detectors for liquid chromatography**

It is clearly seen from Table 1.2 that generally the detection limit of a fluorescence detector is approximately ten times better than UV detector.

Table 1.2 Comparison of LC detectors [39]

Factor	Ultraviolet (UV)	Refractive Index (RI)	Fluorescence	Electrochemical
Specificity	Selective	Universal	Selective	Selective
Detection limit	$10^{-10}$ g ml <sup>-1</sup>	$10^{-7}$ g ml <sup>-1</sup>	$10^{-11}$ g ml <sup>-1</sup>	$10^{-11}$ g ml <sup>-1</sup>
Gradient compatible	Yes	No	Yes	No
Major limitations	Non-UV active solvents only	Low sensitivity, precise temperature control required	Limit dynamic range	Compound adsorption, no electroactive solvents

### 1.4.3 On-line nuclear magnetic resonance (NMR) spectroscopy-liquid chromatography

Nuclear magnetic resonance spectroscopy is very powerful method for identifying the structure of organic compounds. When a radio frequency ( $\nu$ ) is applied to nuclei with a spin ( $J \geq \frac{1}{2}$ ) immersed in a magnetic field, if they absorb the energy which resonate to the energy difference ( $\Delta E$ ) between low an high energy state, it promotes a population difference of nuclei between those two states. Nuclei that are active to the radio frequency in the magnetic field are  $^1\text{H}$ ,  $^{13}\text{C}$ ,  $^{19}\text{F}$ ,  $^{31}\text{P}$  and  $^{15}\text{P}$ , etc. The energy difference ( $\Delta E$ ) between two states is given by the equation:

$$\Delta E = h\nu \quad \dots\dots\dots(3)$$

and

$$\nu = \frac{\gamma B_0}{2\pi} \quad \dots\dots\dots(4)$$

Where  $\gamma$  = the gyromagnetic ratio (a constant differing for each nucleus),  $B_0$  = magnetic field strength, and  $h$  = Plank constant.

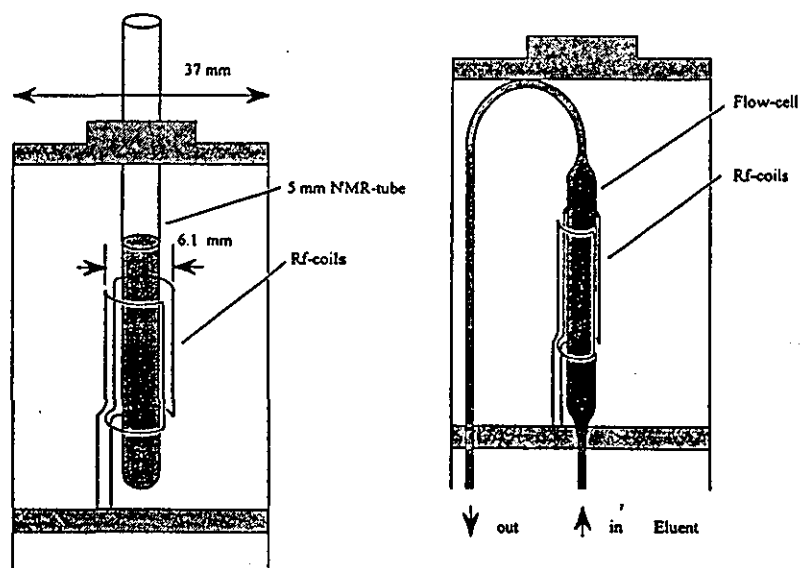
The mechanism by which nuclei transfer energy from higher to lower state is called the *relaxation* process and is characterised by a *relaxation time*,  $T$ , which is equal to the time to bring half of the nuclei back to equilibrium. In spin-lattice relaxation,  $T_1$ , the energy is lost to inter- or intramolecular component in the sample ("lattice"). This process is of importance, if it is operating efficiently; it produces narrow lines on a NMR spectrum, called *high-resolution spectra*. Spin-spin relaxation,  $T_2$ , is less important and it gives broad-line spectra. This process occurs by losing energy to neighbouring spins usually in solid state.

By collecting the current induced from energy decay to lower state as a function of time, a time-domain spectrum or generally called *free-induction decay* (FID), can be achieved. FID yields a NMR spectrum by Fourier transformation using a computerising system, allowing an increase in sensitivity and resolution of NMR as a function of time. Thus, a 2-dimensional NMR plot or a COSY (Correlated SpectroscopY) spectrum can be obtained.

The on-line coupling of liquid chromatography to NMR is very powerful, and convenient as components in a mixture can be separated and the structures can be identified simultaneously by NMR [66-75]. However, since the first on-line couplings of LC-NMR were achieved by Watanabe [67] and Bayer [68], some serious problems involved with the method have arisen, for example a lack of knowledge in the measurement of the spectra in flowing system, solvent signals problem, a low sensitivity of the technique, etc. Some factors therefore must be taken into consideration when coupling those two techniques.

There are a few requirements in the NMR probe head construction. These are a relatively large volume to accommodate the analyte concentration for

NMR measurement, and the detector volume should not exceed the volume of a separation peak, an optimal synchronisation of the flow cell geometry with the measuring coil so that no turbulent flow arises in the flow cell [68]. The configuration of a Bruker NMR flow-probe head compared to a conventional NMR probe is shown in Figure 1.4.



**Figure 1.4** Geometry of conventional and continuous-flow NMR probes [69].

A commercial “inverse” continuous-flow NMR probe from Bruker consists of a non-rotating glass tube to which the  $^1\text{H}$  radio frequency coil is directly fixed at the centre of a conventional probe body. The glass wall of the tube (2, 3, or 4 id. mm) is 18 mm long parallel to the coil and tapered at both ends to fit 0.25 mm id. PTFE tubing. The  $^1\text{H}$  coil is surrounded by an additional coaxial coil of which frequency is matched to  $^{13}\text{C}$  resonance frequency for heteronuclear  $^1\text{H}/^{13}\text{C}$  shift correlated experiments. With this probe configuration, very sensitive NMR measurements can be performed without rotation of the NMR tube. A large number of applications have been published on the coupling of LC-NMR, such as pharmaceutical [70-74], and environment samples [75].

### 1.4.3.1 Solvent effect

Changing the solvent means altering the environment of the solute, thus it may affect the chemical shift of the nuclei in a compound. This effect is found mostly in polar compounds. It arises especially if the solvent molecules arrange themselves around the solute molecules in a different orientation or if there is hydrogen bonding. Table 1.3 gives some example of chemical shift differences due to different solvents [66]. It can be seen that aromatic solvents shift the signal to higher field strength for many of the solutes, this is because the solute tends to interact mostly at the ring face of aromatic ring.

**Table 1.3** Chemical shifts  $\delta$  of solutes in different solvents [66]

Solute	Solvent				
	$\text{CDCl}_3$	$(\text{CD}_3)_2\text{SO}$	Pyridine	Benzene	$\text{CF}_3\text{COOH}$
Acetone $(\text{CH}_3)_2\text{CO}$	2.17	2.12	2.00	1.62	2.41
Chloroform $\text{CHCl}_3$	7.27	8.35	8.41	6.41	7.25
DMSO $(\text{CH}_3)_2\text{SO}$	2.62	2.52	2.49	1.91	2.98
Cyclohexane $\text{C}_6\text{H}_{12}$	1.43	1.43	1.38	1.40	1.47

Chloroform molecules as pure liquids are bound by dipole-dipole interaction but at infinite dilution in an inert solvent, the bond is weakened and the resonance then shifts to a higher field.

As solvents with protons cause difficulties in NMR measurements, to suppress the solvent signal, a deuterated solvent or solvent without proton, i.e. deuteriochloroform ( $\text{CDCl}_3$ ) or carbon tetrachloride, is usually employed

[46]. However, in some circumstances, it is unavoidable to work with aqueous media, and deuterium oxide seems to be the most suitable solvent to replace normal water, despite the trace HOD signal at ~4.8 ppm which occurs from atmospheric deuterium exchange of D<sub>2</sub>O to HOD. If this signal is large, it tends to hinder the signal of the solute, leading to some difficulties such as:

- some solute signals may be hidden.
- integration in that region is difficult and probably not possible.
- a difficulty in computer processing of weak signals with strong signals.

If the relaxation time of the solvent is greater than of the compounds, a useful method to suppress the solvent signal is by using a pulse sequence [76]. For example the water signal (H<sub>2</sub>O or HOD) has  $T_1$ -value about 3 s and is greater than the value for protons in organic molecules. By using the same pulse sequence as for  $T_1$  measurements, the delay time is chosen so that the water signal disappears. Protons of the compounds can subsequently undergo the relaxation mechanism and exhibit the signal.

Another method to suppress the solvent signal is irradiation with a field of greater amplitude at the frequency of solvent signal, resulting in a decrease in signal intensity. The drawback is that the intensity of any sample signals lying in this region will also be suppressed. An alternative to solve the solvent suppression is by switching off the decoupler of the system a few tenths second before recording data. The suppression is more effective if a reduced decoupler power is used with compensation by a cyclic repetition of irradiating and waiting phases before each pulse [76].

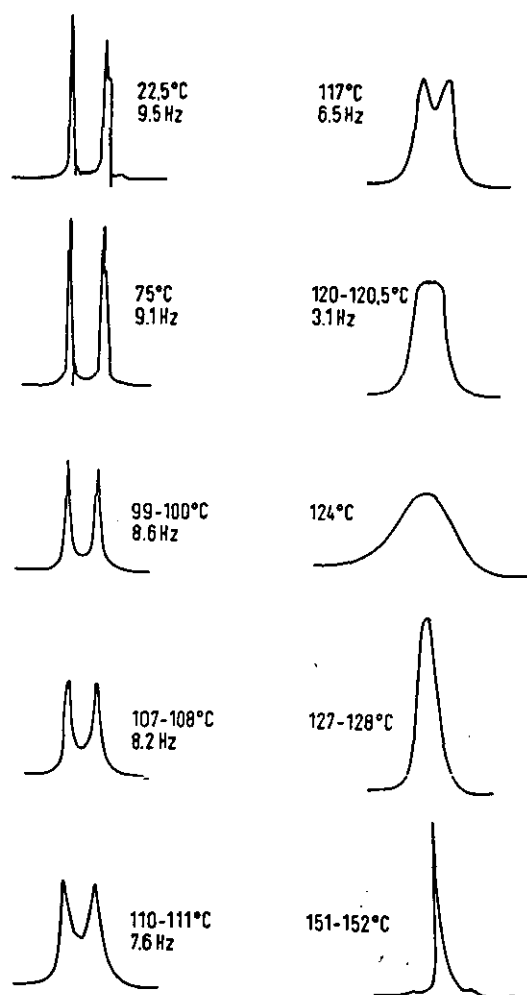
Although the change in solvent composition can affect the chemical shift of the analyte, a number of studies in LC-NMR were performed using gradient elution and then suppressing the solvent signal by a nuclear Overhauser effect spectroscopy (NOESY) pulse sequence method [70-75,77]. Lindon *et al.* [70] evaluated the effects on H-1 NMR chemical shifts of pH and of varying proportions of acetonitrile and water as occurred during the gradient elution HPLC run.

An alternative solvent for suppression of the solvent signal is the use of liquid carbon dioxide, which is generally used as a main mobile phase in SFC. The CO<sub>2</sub> fluid does not give a NMR resonance signal, when employed without any modifiers. Methods to suppress the solvent signal background are therefore unnecessary and the observation of the whole spectrum is possible [78]. However, the need of a back pressure regulator and heating system to maintain the liquid in the probe-head under supercritical CO<sub>2</sub> conditions complicates the system [69].

#### 1.4.3.2 Temperature effect

Because the resonance position of most signals is slightly effected by temperature, a typical NMR detection cell is generally kept at constant temperature. In some circumstances, a variation in temperature affects the chemical shift [79]. To understand the reason of a drift in chemical shift with temperature, we have to consider *averaged chemical shifts* of rotating isomers and their population variation with temperature. For example, in a study of dimethylformamide ((CH<sub>3</sub>)<sub>2</sub>NCHO), at +22.5 °C two methyl signals are observed at 2.79 and 2.94 ppm (Figure 1.5) [76]. When the temperature is raised to +100 °C, those two signals broaden and at 120 °C they became one broad peak. The broad peak became narrow, as the temperature is raised further. This phenomenon can be explained by a different magnetic environment of the two methyl groups at low temperature and as temperature raised the C-N bond of dimethylformamide allows rotation. The rotation rate is faster with temperature so that the two methyl groups cannot be distinguish by NMR.





**Figure 1.5** 56.4 MHz  $^1\text{H}$  NMR signals of the methyl protons in dimethylformamide, recorded at different temperatures [76]

Compounds with hydroxyl groups always exhibit the proton of OH resonance at low field (4-10 ppm). Raising the temperature can cause the OH, NH, and SH protons to resonate at a higher field [80] because it reduces the degree of hydrogen bonding. For example, water gives a very strong solvent signal and the signal is temperature dependent, at 24 °C the resonance is ca. 4.8 ppm, when the temperature raised to 80 °C the resonance is shifted to higher field (ca. 4.4 ppm) [76]. Thus, sometimes it is useful to increase or decrease the temperature to uncover a hidden peak in that region.

A change in temperature can also affect the spin-lattice relaxation,  $T_1$  [81]. For instance, in the case of dimethylformamide, at 215 K the cis- and trans-methyl group to CO exhibit the  $T_1 = 4.3$  and 1.3 s, respectively, but on raising the temperature to 304 K the  $T_1$  of both isomers increases to 17.1 and 11.4 s.

In SFC good agreement was found in an investigation by Albert *et al.* [82] that with CO<sub>2</sub> as the mobile phase, increasing the temperature caused an increase in  $T_1$  value. Changing from liquid to supercritical state also increases  $T_1$  value, owing to a decrease in viscosity; consequently data acquisition takes longer because it prolongs the time that the excited nuclei need to equilibrate back to equilibrium. For butyl-benzene, the  $T_1$  of methyl, methylene, ester and aromatic group, which are 2.8, 2.5, 2.3, and 4.1 s at 304 K increased to 4.3, 3.7, 3.0, and 7.5 s, respectively, at 321 K, at constant pressure in liquid state and then further increased to 8.0, 8.6, 8.8, and 19.6 s in the supercritical state.

With an SFC-NMR instrument, to obtain good resolution NMR spectra, the NMR probe must be a pressure-stable flow cell with a temperature controlling system in order to keep the fluid under supercritical conditions [48] for several hours, particularly when using the stop-flow mode\*. Imperfect temperature control during experiment can cause a drift of the signal in NMR contour spectrum.

An investigation by Allen *et al.* [83] was contradictory. They found that as temperature increased the spin-lattice relaxation time decreased. For example the spin-lattice relaxation time of benzene dissolved in CO<sub>2</sub>, at constant pressure 2500 psi and 296 K,  $T_1$  was 31.6 s, whereas increasing temperature to 355 K and constant pressure can decrease  $T_1$  to 6.7 s but this findings has not been confirmed. It was also noted in their experiment that NMR line broadening could be caused by a thermal gradient in SFC-NMR probe. At a

---

\* see also the section "Sensitivity of NMR detection".

flow rate of  $2 \text{ ml min}^{-1}$ , the line width increases from  $\sim 2.9 \text{ Hz}$  at ambient temperature to  $3.4 \text{ Hz}$  at  $49^\circ$  and  $69^\circ \text{C}$ .

#### 1.4.3.3 Pressure effect

Generally a NMR measurement is performed at ambient temperature and pressure, a study of pressure effect on NMR therefore is of great interest in the chemical physics field, since compression slows down all motions in normal fluids [84], leading to an investigation of the in dynamic properties of the fluids.

Changing pressure by compression has an effect on the density of a liquid, therefore the spin-lattice relaxation time ( $T_1$ ) is altered [85]. This effect is most obvious in SFC-NMR. Albert *et al.* [48, 82] revealed that on increasing the pressure of  $\text{CO}_2$  mobile phase in SFC-NMR, the signal shifts to higher field. A contour plot of proton chemical shifts of chloroform in supercritical  $\text{CO}_2$  with a pressure gradient ranging from 90 bar to 244 bar showed that the relationship was not linear and approximately inversely proportional to the pressure change. This cause could be related to only a change in density of  $\text{CO}_2$  with pressure because no other chemical process was involved. The investigation revealed that the use of on-line coupling between SFC and NMR can be done at a certain range of optimal pressure, otherwise the spectrum would exhibit an extreme signal line broadening. He also confirmed that reducing the viscosity of supercritical liquid mobile phase could cause an increase in spin-lattice relaxation time,  $T_1$  [48].

#### 1.4.3.4 Sensitivity of NMR detection

Compare to other spectroscopic method, e.g. UV or fluorescence, NMR is relatively insensitive because the energy gap between ground and excited state is very small. Therefore, developments are aimed at sensitivity improvement. From the Boltzman distribution relationship, a method to

improve the sensitivity of NMR is to increase the population by increasing the magnetic field strength. In practice, increasing the field strength from 100 MHz to 400 MHz, which is equivalent to changing field from 2.3 to 9.2 Tesla, can improve a signal to noise ratio from 50:1 to 800:1 but improving this technology causes construction and operational costs [86].

Low sensitivity of NMR detection seems to be the main problem since the early stages of the coupling to LC. Despite of the problem, Bayer [68] could detect anisole at a detection limit of 0.5  $\mu\text{mol}$  with the on-flow method.

A dramatic improvement in LC-NMR sensitivity was a contribution to NMR probe designed by Wu *et al.* [87]. Very small radio frequency coils wrapping directly around 75-530  $\mu\text{m}$  id. x ca. 1 mm fused silica capillary were used as a NMR detection cell with a volume of ca. 5-200 nL and less than 50 ng of limit of detection of amino acids were achieved for 1 min data acquisition times. With this new design, they claimed that the limit of detection of CE-NMR could be reduced to near 1  $\text{mg ml}^{-1}$  concentration of nanoliter volume of analyte. However, this design seems to be not practical for routine analysis.

Thanks to a development in Fourier Transform technology in computerising system, a sensitivity improvement can be achieved by an accumulation of a positive responses of true NMR absorption data [86]. This process however requires a long measurement time. Therefore, for an on-line separation, the LC separation is stopped when the analyte is in the NMR flow cell and the data acquisition is then started. This method is known as a stop-flow mode and is recommended for the examination low concentrations of analytes. A number of papers have been published using this method to determine samples from urine [72-73], and natural products [74]. Spraul *et al.* [77] observed that the detection limit of on-line HPLC-NMR in their experiment was ca. 1  $\mu\text{g}$  on column for a stop flow method and ca. 10  $\mu\text{g}$  for a continuous flow method. A study by Albert *et al.* [69] also confirmed that a detection limit of a continuous flow is ten times lower than a stop flow method.

Recently, on-line quantitative HPLC-NMR was achieved for the first time to analyse real environmental sample by Godejohann *et al.* [75, 88]. They used extremely low flow rate at  $0.017 \text{ ml min}^{-1}$  but with a large volume of injection (400  $\mu\text{L}$ ) of nitroaromatic compounds. They also improved the sensitivity by decreasing the flow rate of mobile phase in continuous flow HPLC-NMR, achieving a detection of 1,3-dinitrobenzene 5  $\mu\text{g}$  on column. They proposed two internal standard methods for quantitation but there were some limitations, i.e. an error of quantification results caused by integration of overlapping signals of co-eluting compounds, a relaxation time that need to be determined prior to quantification, and a drastic decrease in precision with decreasing S/N ratio.

The most novel approach in developing a NMR flow cell to improve the sensitivity is to use a saddle-type radio frequency (rf) coil (2 mm id.) wound directly on a glass tube (2 mm od.) inserted with a 60  $\mu\text{m}$  id. fused-silica capillary tube, as a NMR probe [89-91]. The configuration is different from one designed by Wu *et al.*, as the rf coil is not permanently attached to the fused silica. Therefore, the fused silica is easily exchanged without damaging the coil but the detection volume is higher (240 nL) than Wu' s design and the detection limit of 336 ng (or equivalent to 2.3 nM) of amino acid was achieved.

#### 1.4.4 Mass spectrometry (MS)

Mass spectrometry is one of the most useful methods in analytical chemistry today. Compared to other molecular spectroscopic techniques; mass spectroscopy possess a high sensitivity in determination, identification and quantification of trace amounts of compounds [65]. A useful application is extended by coupling to gas and liquid chromatography on-line for simultaneous separation and quantification [92-93].

In brief, the functions of mass spectrometry are described by the following basic tasks: (1) vaporise compounds into gas phase, (2) ionise the gaseous compounds to produce ions, (3) separate the ions according to their mass to charge ratio by a mass analyser and (4) detect and record the separated ions. In many cases, the first and second tasks are combined into one step. There are a number of ionisation methods, for instance electron impact (EI), chemical ionisation (CI), fast atom bombardment (FAB), thermospray (TS), atmospheric pressure ionisation (API), electrospray (ES), etc. The details of how to process the ions by each methods have been given elsewhere [94-96] and a comparison of each method is given briefly in Table 1.2.

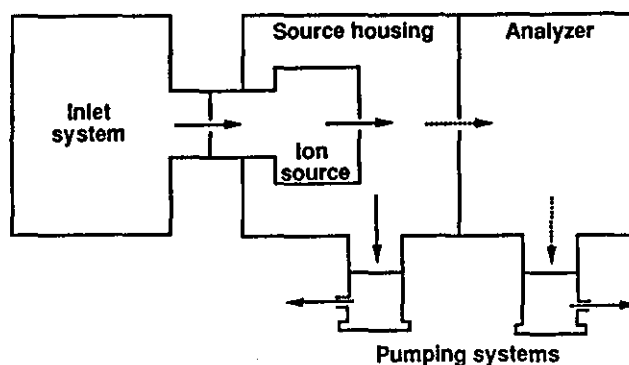
**Table 1.4** Comparison of ionisation methods for MS [97].

Ionisation method	Sample preparation for ionisation	Thermal input associated with ionisation	Information available	Sample type	Molecular weight limit
Electron impact (EI)	As vapour	Relatively high	Fragment ions and often molecular ion	Nonpolar or moderately polar	750
Chemical ionisation (CI)	As vapour	Relatively high	Molecular ion and sometimes fragment ions	Nonpolar or moderately polar	1,000
Thermospray with discharge ionisation	Dissolved in solvent	Relatively low	Molecular ion and sometimes fragment ions	Nonpolar or polar	2,500
Fast atom bombardment (FAB)	Dissolved in matrix such as glycerol	Virtually none	Molecular ion and sometimes fragment ions	Usually polar	10,000
Electrospray (or ion-spray)	Dissolved in solvent	Virtually none	Molecular ion only	Polar	50,000

#### 1.4.4.1 Solvent, flow rate and pressure

Because the molecules or ions that transfer to MS must be in the gas phase and the sample from liquid chromatography is in a liquid or solution, when coupling the LC to MS, an interface for changing the liquid sample to gaseous sample is therefore necessary. However, there is not a perfect interface and ionisation technique in all applications, since each interface and ionisation technique is appropriate in some conditions and is compound dependent. It is also extremely difficult to achieve a solvent evaporation and a solute transference to ion source at the same time without loss of sample or degradation. Evaporation of the liquid mobile phase into a gas expands the volume, for example at the flow rate  $1 \text{ ml min}^{-1}$  of mobile phase generates  $100\text{--}1000 \text{ ml min}^{-1}$  of gaseous flow [45]. A vapour flow of  $6.25 \text{ ml min}^{-1}$  is equivalent to water at a flow rate of  $5 \mu\text{l min}^{-1}$  and acetonitrile at a flow rate of  $15 \mu\text{l min}^{-1}$ . Only a small flow of vapour about  $5\text{--}7.5 \text{ ml min}^{-1}$  is admitted to the ion source under normal circumstances, hence the input of the LC effluent to the interface requires a splitting device.

All the flow that enters the ion source is ionised and then partly pumped away at the source housing (see Figure 1.6). A mass spectrometer is typically operated under high vacuum ( $1 \times 10^{-4}$  torr in the source region and  $1 \times 10^{-5}$  torr in the analyser) and the LC operates at a high pressure mode ( $>1.0 \times 10^3$  torr), therefore an evacuation system (usually between  $1\text{--}10 \text{ ml min}^{-1}$ ) in the MS instrument is necessary and the selected operating pressure depends on many factors, such as the nature of the mobile phase.



**Figure 1.6** Schematic representation of a mass spectrometer vacuum system [97].

**Table 1.5** Comparison of LC-MS interfaces in terms of allowable flow-rate and mobile phase composition [97]

<b>Interface</b>	<b>Maximum flow-rate (ml min<sup>-1</sup>)</b>	<b>Mobile phase Composition</b>
Moving-belt	2	Organic solvent
	0.5	Reversed phase solvents, no buffers
Direct liquid introduction	0.05	Reversed phase solvents, no buffers
Thermospray	2	Reversed phase solvents with volatile buffers
Continuous flow-FAB	0.015	Reversed phase solvents with volatile buffers
Particle beam	0.5	Reversed phase solvents (not too aqueous) with volatile buffers
Electrospray/Ionspray	0.5	Reversed phase solvents with volatile buffers
Heated nebulizer/APCI	2	Reversed phase solvents with volatile buffers

Non-volatile components of the mobile phase are one of the major problems in most interfaces and ion sources [96-97]. Volatile buffers can be used and generally contain ammonium acetate, ammonium formate, ammonium



hydroxide, acetic acid or trifluoroacetic acid. The long term use of non-volatile buffers, such as phosphate buffers and ion-pairing reagents, are not acceptable in most interfaces and ion sources, but some interfaces, such as atmospheric chemical ionisation (APCI) with counter-current drying gas, are more tolerant than others [96]. To meet this requirement step, such as the removal of all non-volatile modifiers or changing the mobile phase system, must be adopted for a particular application, although it is sometimes extremely difficult from the chromatographer's point of view.

Nevertheless, the recent design of some interfaces, namely electrospray or APCI, can deal with involatile buffers. The detail of electrospray interface and the mechanism of ionisation will be given later (section 1.4.4.4).

#### **1.4.4.2 Sensitivity of MS detector**

Since the sensitivity of LC-MS depends on many factors, i.e. the interface, the flow rate of mobile phase, the nature of analytes, the operating conditions, etc., hence, to identify the sensitivity of the technique by judging from one particular application is not acceptable. Also, a selection of interface to be used for one application depends on the type of application, for example in qualitative work informative fragmentation is desirable, hence, a particle beam interface with an EI source is most attractive. For a quantitative analysis, only a few peaks on a MS spectrum are sufficient and if maximum sensitivity is required, atmospheric pressure chemical ionisation (APCI) offers the best choice [97]. Table 1.4 demonstrates a comparison of detection limit with various interfaces, revealing that APCI gives the lowest detection limit for N-methyl carbamates with the highest flow rate  $1 \text{ ml min}^{-1}$ . However, some applications may be different from the trend given in the table.

**Table 1.6** Comparison of single-ion detection limits in the LC-MS analysis of *N*-methyl carbamates with various interfaces [97]

Interface	Detection limit (ng)				Flow-rate (ml min <sup>-1</sup> )
	Methomyl	Aldicarb	Carbofuran	Carbaryl	
Moving-belt (methane CI)	-	6	25	3	0.5
Direct liquid introduction	-	-	50	40	0.02
Thermospray	2.8	0.9	0.8	0.8	1.0
Ionspray	0.4	1.5	1.5	1.0	0.05 after 20:1 split
APCI	0.06	0.07	0.05	0.05	1.0
Particle-beam with EI	250	500	55	10	0.4 after 3:2 split

In this decade, electrospray has grown in application, due to biochemical studies, but it is typically only used as a sample introduction device in an on-line LC-MS.

#### 1.4.4.3 SFC-MS

In on-line coupling of SFC with MS, CI is the most favourable technique in ionisation, as the MDQ is in a range of picogram level and comparable to GC/MS [98-99]. In the case that the liquid passing through the ionising chamber is supercritical fluid such as CO<sub>2</sub>, in EI mode the detector is normally scanned from *m/z* 100 because the [CO<sub>2</sub>]<sup>+</sup> and [(CO<sub>2</sub>)<sub>2</sub>]<sup>+</sup> are formed at *m/z* 44 and 88. The formation of CO<sub>2</sub> cluster ions can be prevented by a heat expansion region in which the temperature was raised 50-150 °C higher than the mobile phase temperature. The details of the effects of temperature and pressure on CO<sub>2</sub> cluster ions have been reported [100].

A restrictor at the end of the column is also needed to maintain the pressure. It was reported that the best flow conditions of capillary SFC were obtained when short restrictors were employed [101] and additional heat must be applied to the end of restrictor to compensate for the cooling during decompression, to prevent solute precipitation and, to some degree, to initiate the vaporisation. The restrictor tip temperatures are typically 250-400 °C. If the temperature is too high, it increases in the expanding gas viscosity, resulting in a decrease in the column flow. The injected split ratio then increases and the signal disappears [47]. Therefore, the optimal temperature must be adjusted, depending on the supercritical fluid and the analyte. In addition, to improve the sensitivity in capillary SFC/MS the choice of the restrictors must be considered [101].

By increasing the ion source temperature, the fragmentation of ions can be increased [94] but the effect of temperature on fragmentation can be minimal when supercritical methane is used.

With increasing the source pressure in EI SFC/MS, a loss in sensitivity is due to the scattering of the ions from the entrance to the mass analyser by the ion source [47]. Cousin *et al.* [102] revealed that the loss in sensitivity with increasing pressure of high molecular weight compounds was because of the higher collision of the heavy ions than the lighter ions.

Since a narrow bore column generates a smaller gas volume from the mobile phase fluid than a conventional column, it gives less interface problem and allows all the eluent from SFC to pass to MS.

#### **1.4.4.4 Electrospray LC-MS**

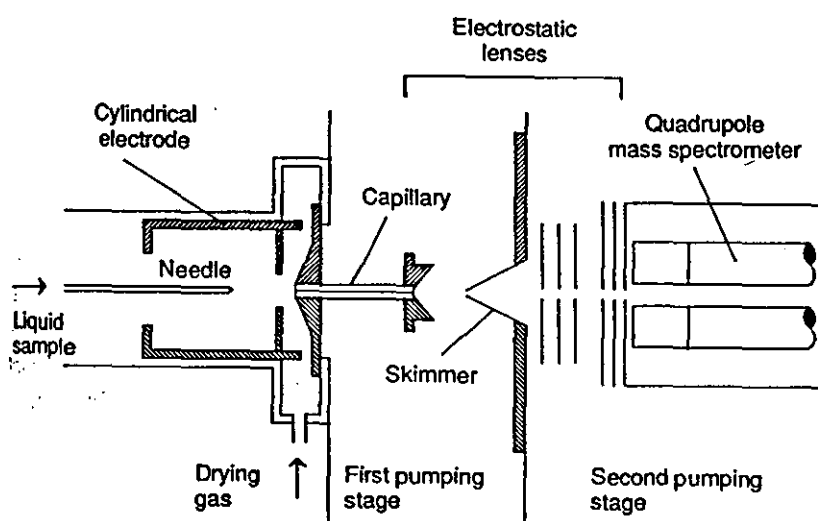
As mentioned earlier recently the application of the electrospray interface has been increasing, this is a consequence of a new exploration of a potential of the electrospray and its application to the characterisation of non-volatile

macromolecules, such as nucleotides, peptides, and proteins. A molecular weight of more than 400,000 daltons can be determined by using electrospray [103], whereas it is more difficult to ionise those molecules by other methods.

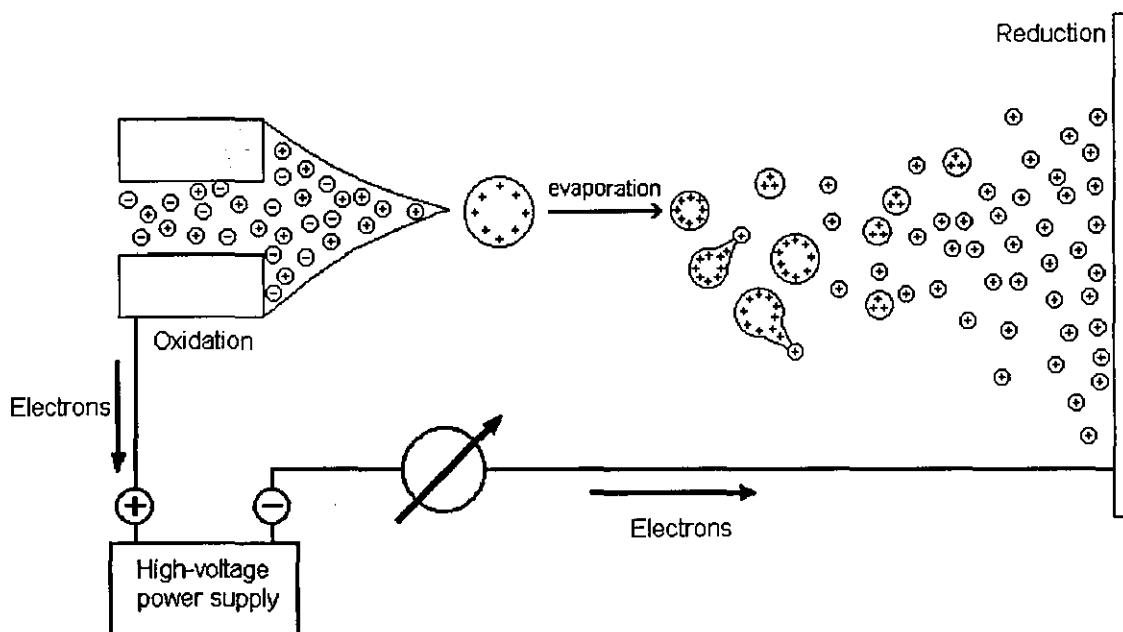
The first experiment with the electrospray as a sample introduction method for MS was carried out by Dole *et al.* [103] in 1968. At that time, heating a macromolecule could result degraded products before it evaporated. By using electrospray, as the solvent evaporates, the drop shrinks and becomes electrically unstable and breaks down into smaller drops. The charged drops repelled each other and prevent aggregation. When a macromolecule solution was electro-sprayed into a vacuum, the drops would not evaporate within less than a second because of the strong evaporative cooling of the drop, therefore, heat must transfer to the drop to accelerate the evaporation. Because of the Van de Waals attraction between macromolecules, two macromolecules colliding in the gas phase will associate and then aggregate during evaporation. However, if the macromolecules are charged, the electrostatic force will keep them apart and prevent aggregation. To distinguish between high mass macro-ions and low mass solvent molecules, a repeller grid were adopted and applied voltage on the grid would screen out due to a difference between electric repulsive energy of low and high mass ions. In this approach, macromolecules of molecular masses up to 411,000 could be detected

The first commercial electrospray interface for LC-MS was developed by Whitehouse *et al.* [104] (Figure 1.7). The sample was introduced through a hypodermic needle to the electrospray chamber with a flow rate of 5-20  $\mu\text{L min}^{-1}$ . To produce positive ions, voltages were applied to the needle (ground potential), the cylindrical electrode (-3.5 kV), the metallized inlet (-4.5 kV) and exit ends (+40 V) of the 0.5 mm. id. glass capillary, the skimmer between first and second vacuum stage (-20 V), and the ion lens in front of the quadrupole (-1.0 kV). The surface of the introduced liquid was charged by the high field at the hypodermic needle tip and became dispersed by coulombic forces into

a fine spray of charged droplets (Figure 1.8). Under the electric field potential, the droplets flowed to the inlet of the glass capillary through a hot stream (50 – 80 °C) of nitrogen gas at a pressure of ca. 1000 torr, allowing solvent evaporation from each charged droplet. The solvent vapour and uncharged droplets were swept away by the flow of bath gas, whereas each charged droplet decreased in diameter. The charge density thus increased on its surface until coulomb repulsion becomes stronger than surface tension [105]. “Coulomb explosion” fractured the droplets, forming charged daughter droplets and evaporation happened again. This process was repeated until charged molecular ions in ambient gas were formed. Some of them are entrained in dry bath gas that entered the capillary inlet and are transported to the first vacuum chamber, emerging at the exit end as a supersonic molecular beam and passing through a second vacuum chamber to the quadrupole analyser.



**Figure 1.7** Schematic diagram of the apparatus for mass spectrometry with an electrospray ion source [104].



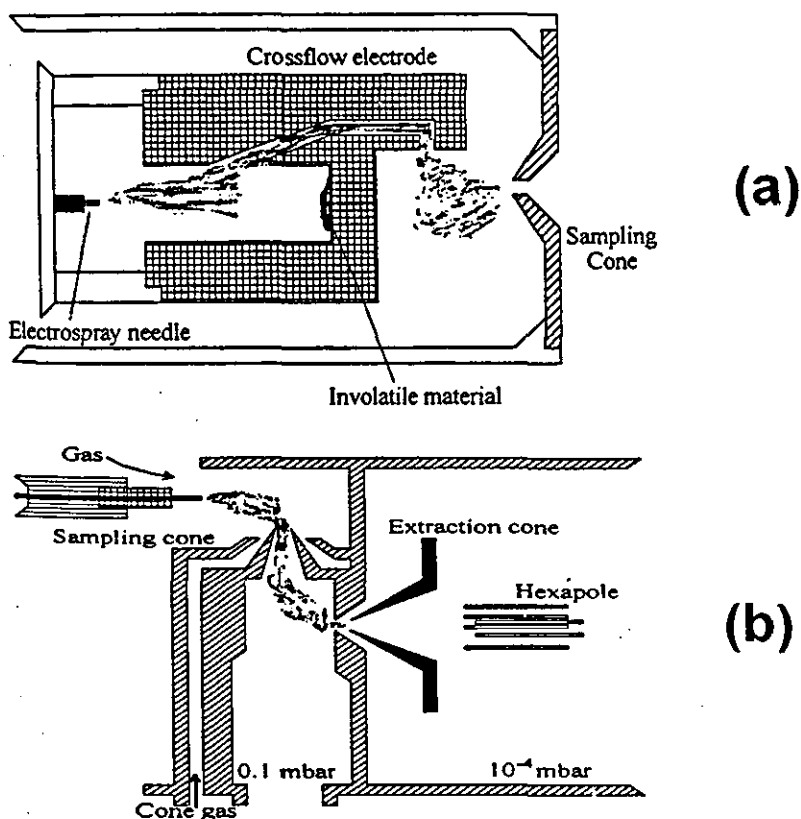
**Figure 1.8** Schematic representation of processes in electrospray MS [106]

The ion-spray source developed by Bruins *et al.* [107] in 1987 had a similar ionisation mechanism, but has the advantage of a higher flow rate over the conventional source. A flow rate of  $200 \mu\text{L min}^{-1}$  can be employed. Nitrogen gas flowed around the sample orifice to prevent clogging by non-volatile material. In some approaches, in order to improve ion transmission efficiency and to dissociate the cluster ions, three-stage differentially pumped vacuum systems were used [108-110] and a drift voltage was applied between two skimmer-shaped electrode [110]. In a system design by Vestec, ambient gas replaced nitrogen gas, no counter current gas is employed and the skimmer was heated to  $200\text{-}250 \text{ }^\circ\text{C}$  [109].

In a conventional electrospray, the spray device is positioned axially to sample orifice, as seen in Figure 1.7. An ES introduction system developed by Hewlett-Packard [111] placed the spraying device in orthogonal position. This set-up showed many advantages, i.e. a reduction in the contamination of

the orifice, more intense signals, and the use of high flow rates up to  $4.4 \text{ ml min}^{-1}$  without experimental difficulties.

To improve the tolerance for non-volatile materials, different designs of electrospray source from Micromass, such as a crossflow device (Figure 1.9 a) or "Z" spray (Figure 1.9 b), were introduced [112]. A crossflow device contains a deep well, where the non-volatile species are collected, and then the spray is blown across through the crossflow electrode to the orifice of sampling cone. In the "Z" spray device, ions are produced and orthogonally flow from the outlet into the high vacuum chamber. Mobile phases containing phosphate buffer can be used with this system.



**Figure 1.9** Schematic diagram of the Micromass (a) crossflow, and (b) "Z" spray electrospray source.

### 1.5 Aim of research

As adding modifiers to a mobile phase has a potential effect on many separations in conventional LC [113], the present work was aimed to investigate the use of modifiers, such as inorganic buffers and ion-pairing reagents, in a superheated water mobile phase. A series of sulfonamides were examined and the separation was compared to that of conventional LC separations. The  $pK_a$ s of some sulfonamides at elevated temperature were also examined and compared to those investigated under ambient conditions.

The successful on-line coupling of liquid chromatography (LC and SFC) to a number of widely used detectors, namely fluorescence, NMR and MS, lead to an interest in the feasibility of employing these coupled detection methods to superheated water chromatography. In this work, the investigation will be further expanded to the use of buffer mobile phases with the coupled system. An examination of the separation of a number of model compounds, analgesics, sulfonamides, some B-vitamins, etc., and their identification by using those detectors will be carried out. The feasibility of the hyphenation of on-line superheated water chromatography-NMR-MS will also be examined.



---

---

## Chapter 2

---

---

# Experimental

### 2.1 Chemicals

#### 2.1.1 General chemicals

Phosphoric acid ( $\text{H}_3\text{PO}_4$ ) and disodium hydrogen phosphate ( $\text{Na}_2\text{HPO}_4$ ) were of laboratory reagent grade obtained from Sigma (Sigma Chemicals, Poole, Dorset, UK).

Potassium dihydrogen phosphate ( $\text{KH}_2\text{PO}_4$ ), sodium hydroxide ( $\text{NaOH}$ ), sodium carbonate ( $\text{Na}_2\text{CO}_3$ ), acetic acid and citric acid were of laboratory reagent grade, boric acid, and sodium hydrogen carbonate ( $\text{NaHCO}_3$ ) were of analytical grade. Acetonitrile and tetrahydrofuran (THF) of HPLC grade were used without further purification. All of these chemicals were obtained from Fisons Scientific (Loughborough, UK).

Tetrabutylammonium bromide of more than 98% purity was from Lancaster Synthesis (Morecombe, England). Tetramethylammonium bromide of 98.5% purity and sodium acetate were from BDH (BDH Chemicals Ltd., Poole, England). Deuterium oxide (D<sub>2</sub>O) was of 99.9% purity from Fluorochem (Old Glossop, UK).

### 2.1.2 Standard chemicals

Sulfonamides used in this study were laboratory reagents obtained from various suppliers: sulfanilic acid, sulfacetamide and sulfisomidine (Sigma, Missouri, USA); sulfamethoxazole, sulfachloropyridazine and sulfaphenazole (Sigma, St.Louis, MO, USA); sulfanilamide (Hopkin & Williams, Essex, England); sulfaguanidine and sulfathiazole (BDH, Poole, England); sulfadiazine, sulfapyridine, sulfamerazine, succinylsulfathiazole and phthalylsulfathiazole (May & Baker, Dagenham, England); and sulfamethazine (K & K Laboratories, USA). N<sup>4</sup>-acetylsulfanilamide and N<sup>1</sup>, N<sup>4</sup>-diacetylsulfanilamide were synthetic laboratory samples.

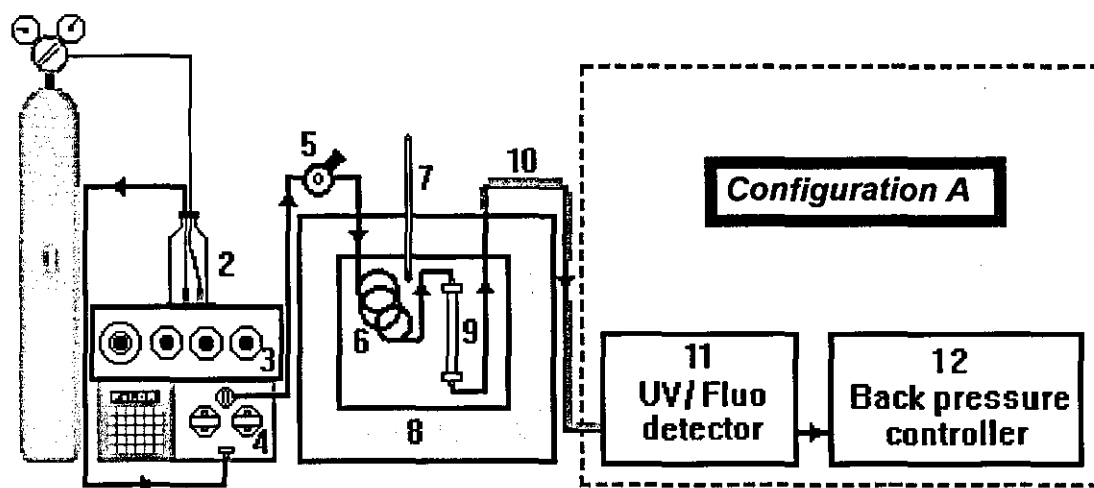
Barbitone, amylobarbitone and heptabarbitone were from the reference collection of the Home Office Forensic Science Service (Aldermaston, Berks, UK). Salicylamide, caffeine, phenacetin and dansylglycine, dansyl-DL-valine and dansyl-DL-leucine were obtained from Sigma (Sigma Chemicals Co., St.Louis, USA). Paracetamol, quinine sulfate and riboflavin were laboratory reagents from BDH (BDH Chemicals Ltd., Poole, England) and pyridoxal hydrochloride was from May & Baker (Dagenham, England).

Thiamine hydrochloride was obtained from ACROS (Acros Organics, Geel, Belgium) and 4-methyl-5-thiazole-ethanol was from Sigma-Aldrich (Aldrich-Chemical Co., Gillingham-Dorset, UK).

## 2.2 Instrumentation, Equipment and Materials

### 2.2.1 Superheated water chromatography

An initial superheated water chromatographic system composed of a typical HPLC system equipped with a GC oven is shown in Figure 2.1. In this set up the detectors were connected in 3 different configurations, A, B, and C, as follows.



**Figure 2.1** Superheated water chromatographic system with detectors as Configuration A type.

The superheated water chromatographic system comprised a LC-10AD Shimadzu pump (Shimadzu, Japan) (4) which delivered mobile phase from a reservoir (2) in a constant-flow mode ( $1.0 \text{ ml min}^{-1}$ ) to a HPLC column (9) through a preheating coil (6) made of a 100 cm x 0.01-inch i.d. stainless steel tubing. The solvent was flushed with nitrogen (1) to deoxygenate it. The

column and preheating coil were placed in a GC oven (Series 104, Pye Unicam, UK) (8) whose temperature was programmed using a programmer controller (Series 104, Pye Unicam, UK) (3) and the temperature was read using a thermometer (7). Sample was injected via a Rheodyne HPLC injector (Model 7125, Rheodyne, Cotati, USA) (5) (external to the oven) fitted with a 20  $\mu$ l sample loop. A set of copper cooling fins (3 cm x 12 cm x 0.05 mm) (10) was attached to the exit tubing to cool the mobile phase down to ambient temperature before the detector(s) (11). A back pressure controller (Jasco 880/81) set at 35 kg cm<sup>-2</sup> or a 0.13 mm i.d. x 3 m length of PEEK tubing were used to maintain the pressure of superheated water in the column (12).

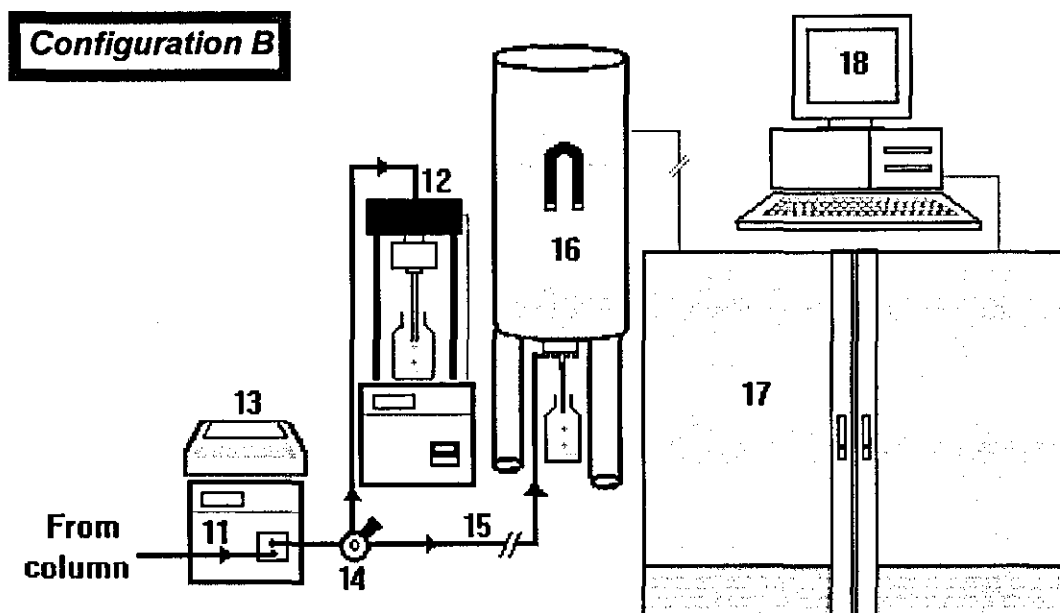
### 2.2.2 UV detector

In the configuration A of Figure 2.1, a Jasco UV/Visible detector (Model 870, Jasco, Japan) with a HP 3395 integrator (Hewlett Packard, USA) was operated at wavelength 254 nm to detect compounds.

### 2.2.3 Fluorescence detector

A SFM25 fluorescence detector (KONTRON, Switzerland) was placed between the UV detector and the back pressure regulator and the signal was detected using a HP 3396A integrator (Hewlett Packard, USA).

## 2.2.4 Nuclear Magnetic Resonance Detector



**Figure 2.2** A configuration B type extended from the superheated water chromatographic system in Figure 2.1.

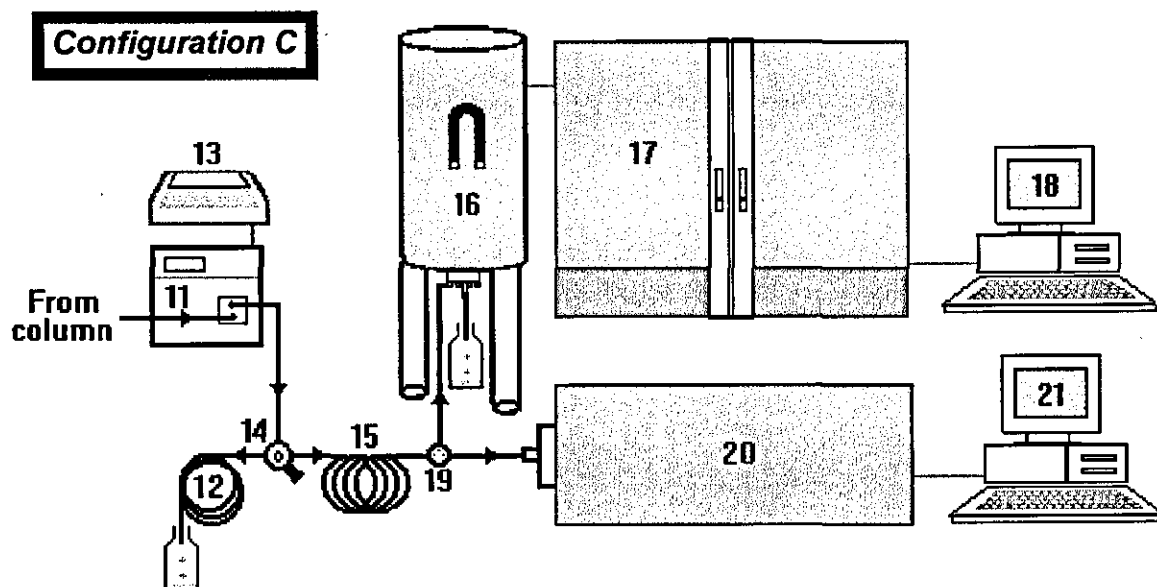
In order to connect the NMR detector to the superheated water chromatographic system, a Rheodyne injector (Model 7125, Rheodyne, USA) (14) was added after the UV detector and used as a switching valve to redirect the flow on demand to a Jasco 880/81 back pressure regulator (12) set at  $35 \text{ kg cm}^{-2}$  or to a 0.13 mm i.d. x 3 m PEEK tubing to maintain to pressure in the column. A second 0.13 mm i.d. x 3 m PEEK tubing (15) from the switching valve was led to a Bruker DRX-500 NMR spectrometer (Bruker UK Ltd., Coventry, UK) (16-18) with a detection cell volume of  $120 \mu\text{l}$ . Under these conditions the transfer time of a selected peak from UV-detector (11) to the NMR probe was 33 s at mobile phase flow rate of  $1.0 \text{ ml min}^{-1}$ .

NMR was performed in the stopped-flow mode on selected peaks and the spectra were measured at 500.13 MHz ( $^1\text{H}$ ). Free induction decays (FID)

were collected over a spectral width of 8278 Hz into 16384 data points using an acquisition of 0.99 s using the NOESY-type presaturation (NOESYPRESAT) pulse sequence (Bruker). The residual water resonance was suppressed using pre-irradiation during the relaxation delay of 2.0 s and mixing period of 0.10 s.

For the 2D-COSY NMR experiment, 1 K data points were used in the F2 domain with the number of experiments set to 256 (TD1). In both dimensions 90 pulses were used over a sweep range of 4990 Hz with a relaxation delay of 1.5 s. A sine-bell window function in both dimensions was applied and data were zero-filled in the F1 dimension, Fourier transformed, and then symmetrised about the diagonal.

### 2.2.5 NMR and Mass spectroscopic detectors



**Figure 2.3** A configuration C type extended from the superheated water chromatographic system in Figure 2.1.

The hyphenated system of superheated water chromatography-NMR-MS (Figure 2.3) comprised the chromatographic system in Figure 2.1 connected to NMR and MS by an outlet tubing from the UV detector. This was equipped with an injection valve (14) (Rheodyne model 7125, Rheodyne, USA) used as a switching valve, which was connected either to PEEK tubing (3 m x 0.13 mm i.d.) or to a second PEEK tube (3 m x 0.13 mm i.d.) (15) leading to a T-piece (19). The two outlets of the T-piece were connected to the NMR spectrometer by PEEK tubing (0.5 m x 0.13 mm) (16-18) and to a Quattro MS detector (3 m x 0.13 mm) (20-21)

The Quattro LC mass spectrometer (Micromass Ltd, Altrincham, Cheshire, UK) was fitted with a Z spray source running two cone voltages (25 and 60 V) in positive electrospray. With a 0.1 s interscan delay, at 25 V the mass range from 80 to 450 amu was scanned over 1 s and at 60 V the mass range from 35 to 450 amu was scanned also over 1 s. The capillary voltage was set at 3.45 kV. The source block temperature was maintained at 80 °C and the desolvation temperature was operated at 150 °C. The nebuliser gas flow and the desolvation gas flow were controlled at 80 and 564 l hr<sup>-1</sup>, respectively.

## 2.2.6 Chromatographic Columns

The following chromatographic columns were employed.

- 15 cm x 4.6 mm i.d. Column packed with 5 µm PRLP-S (polystyrene-divinylbenzene, PS-DVB), Polymer Laboratories, Shropshire, UK
- 15 cm x 4.6 mm i.d. Column packed with 5 µm Nova-pak C18 (octadecyl, ODS) (Waters, USA).
- 15 cm x 2.1 mm i.d. Microbore-column packed with 3 µm ZirChrom-PBD (Polybutadiene) column (ZirChrom Separations, Anoka, Minnesota, USA).

### 2.2.7 Mobile phase

Triply deionised water was treated through a HPLC purification unit (Elga Wycombe, Bucks, UK) at an output of  $>17\text{ M}\Omega$ . The pHs of buffer solutions were measured by using 3 digit pH-meter (Model 520A, Orion Research, Boston, USA).

The mobile phases were degassed by using an ultrasonic bath and/or purged with nitrogen gas (1). When an ion -pair reagent was used a guard column modified as a filter was placed between the pump (4) and the injection valve (5) to trap dust and particulates.

### 2.3 Preparation of standards

Salicylamide was prepared at a concentration of approximately  $10\text{ mg ml}^{-1}$  in acetonitrile. A mixture of analgesics consisting of  $10\text{ mg}$  of each paracetamol, caffeine and phenacetin and a mixture of  $10\text{ mg ml}^{-1}$  of the barbiturates were both prepared in  $1\text{ ml}$   $80\%$  v/v acetonitrile- $\text{D}_2\text{O}$ .

A mixture of approximately  $1\text{ mg ml}^{-1}$  of each sulfonamide in a mixture was prepared in  $20\%$  THF – water. For the NMR studies, a mixture of sulfacetamide, sulfadiazine, sulfamerazine and sulfamethazine consisted of  $10\text{ mg}$  each was prepared in  $3\text{ ml}$   $80\%$  acetonitrile- $\text{D}_2\text{O}$ .

The solutions of riboflavin, thiamine hydrochloride, 4-methyl-5-thiazole-ethanol, pyridoxal hydrochloride, quinine sulfate and dansyl amino acid were prepared by dissolving the pure standards in deionised water,  $\text{D}_2\text{O}$  or deuterated buffers.



## 2.4 Extraction Procedure of kava root sample

The dry roots of *Piper methysticum* from Suva, Fiji, were ground and approximately 1.0 g was weighed into a vial, then 10 ml methanol was added. The mixture was stirred for a few hours and subsequently filtered through Whatman Filter paper No.1. The filtrate was collected and evaporated to dryness by a stream of nitrogen or air. Afterwards, the residue was dissolved in 5 ml ethyl acetate and passed through a 10 cm Pasteur pipette column packed with silica gel 60-150 mesh followed by 5 ml ethyl acetate. The yellow eluent portion was collected, evaporated to dryness by a nitrogen stream and dissolved in ca. 1 ml methanol. The extract was further separated by superheated water chromatography with UV and NMR detection.

## 2.5 Preparation of mobile phase

### 2.5.1 Preparation of buffer pH 3-12

Phosphate buffers at a range of pH were prepared from a combination of phosphoric acid ( $\text{H}_3\text{PO}_4$ ), potassium dihydrogen phosphate, disodium hydrogen phosphate ( $\text{Na}_2\text{HPO}_4$ ) and sodium hydroxide, depending on the pH required, in deionised water or deuterium oxide. Citrate, borate, acetate and carbonate buffers were prepared from individual pairs of citric acid - sodium hydroxide, boric acid - sodium hydroxide, acetic acid - sodium acetate, sodium carbonate - sodium hydrogen carbonate, in water, respectively.

All buffers were prepared at the concentration of 1-3 mM of the anion, namely phosphate, citrate, borate, acetate or carbonate. The pH of every buffer was measured and adjusted during preparation. For example, phosphate buffer pH 7 was prepared by dissolving 0.285 g  $\text{Na}_2\text{HPO}_4$  in 1 l deionised water. The solution was stirred, measured pH and then added conc.  $\text{H}_3\text{PO}_4$  drop by drop until pH = 7.0.

### 2.5.2 Preparation of ion pairing mobile phase

*1 mM tetramethylammonium bromide (or tetrabutylammonium bromide) pH 7.0*

0.280 g Na<sub>2</sub>HPO<sub>4</sub> and 0.160 g (~1 mmole) tetramethylammonium bromide (or 0.330 g (~1 mmole) tetrabutylammonium bromide) were dissolved in 1 l deionised water. The solution was stirred and measured pH, then conc. H<sub>3</sub>PO<sub>4</sub> was added dropwise until pH = 7.0

### 2.6 A calculation of pK<sub>a</sub> value using retention factor

To calculate pK<sub>a</sub> value of the sulfonamides at elevated temperatures, the retention times at different pH were examined, then transformed into retention factors (*k*) by using an equation of retention factor,  $k = (t_R - t_0)/t_0$ , where *t<sub>R</sub>* = retention time of any analytical species and *t<sub>0</sub>* = retention time of unretained species.

The equation relating the retention factor [114] to pH is given by

$$k = \frac{k_0}{1 + \frac{K_a}{[H^+]}} + \frac{k_{-1}}{1 + \frac{[H^+]}{K_a}} \quad \dots\dots\dots(1)$$

where, *k* = retention factor at a given hydrogen ion concentration, *k<sub>0</sub>* = retention factor of the neutral species, *k<sub>-1</sub>* = retention factor of the deprotonated species, *K<sub>a</sub>* = ionisation constant, and [H<sup>+</sup>] = hydrogen ion concentration.

Then the equation (1) is derived by giving  $A = \frac{K_a}{[H^+]}$ .

Hence, 
$$k = \frac{k_0}{(1+A)} + \frac{k_{-1}}{\left(1 + \frac{1}{A}\right)}$$

$$k = \frac{k_0}{(1+A)} + \frac{k_{-1}}{\left(\frac{A+1}{A}\right)}$$

$$k = \frac{k_0}{(1+A)} + \frac{k_{-1}A}{(A+1)}$$

$$k = \frac{k_0 + k_{-1}A}{(1+A)}$$

By replacing  $A = \frac{K_a}{[H^+]}$ ; 
$$k = \frac{k_0 + \frac{k_{-1}K_a}{[H^+]}}{1 + \frac{K_a}{[H^+]}} \dots\dots\dots(2)$$

$k_0$  and  $k_{-1}$  were determined and replaced in equation (2).  $K_a$  was calculated by using Solver function from Excel computer programme. For example, if the retention time of unretained species ( $t_0$ ) was 1.29 min, the retention factors of sulfacetamide at different pH were calculated from its retention times (Table 2.1).

**Table 2.1** Retention times and factors of sulfacetamide at different pHs. The values in circles are the maximum and minimum retention factors, which were determined for the retention factors of neutral and deprotonated species, respectively.

pH	$t_R$ (min)	Retention factor ( $k$ )			
		expt.	Predicted	Difference	
3.0	22.30	16.29	19.50	-3.21	$t_0 = 1.29$
3.5	25.30	18.61	19.24	-0.63	
4.0	26.60	19.62	18.46	1.16	
4.5	22.84	16.71	16.36	0.35	
5.0	18.21	13.12	12.04	1.08	
5.5	8.81	5.83	6.59	-0.76	$k_0 = 19.62$
6.0	3.23	1.50	2.75	-1.25	$k_1 = 0.09$
6.5	2.09	0.62	1.02	-0.40	$k_1 * K_{a2} = 5.71 \times 10^{-7}$
7.0	1.54	0.19	0.39	-0.20	$K_{a2} = 6.34 \times 10^{-6}$
8.0	1.41	0.09	0.12	-0.03	<b><math>pK_{a2} = 5.20</math></b>

$k_0$  = the retention factor of neutral species which was equal to 19.62.  $k_1$  = the retention factor of deprotonated species which was 0.09. We set the equation of predicted  $k$  equal to equation (2) and used Solver function from Excel to minimise the summation of the squares of the difference between the experimental and predicted values by changing  $K_{a2}$  value. The  $K_{a2}$  was estimated to be  $6.34 \times 10^{-6}$  and hence the experimental  $pK_a$  value of sulfacetamide was 5.20.

---

---

## Chapter 3

---

---

# Effect of Additives in the Mobile Phase

### 3.1 Introduction

Recently superheated water was utilised successfully as a pure mobile phase for chromatography with a number of different columns, including Spherisorb ODS1, PRP-1, PRLP-S, PBD-zirconia and Hypercarb [32, 36], and the elution order followed reversed-phase HPLC. A study by Burgess [36] showed that a silica based column, such as Spherisorb ODS1, was not suitable because of the dissolution of silica packing material at high temperatures. A porous graphitic carbon (PGC) column gave only fair separations, whereas a polymeric column, such as PRLP-S, looked more promising because of its better stability at high temperature. However, it was the most retentive phase when using superheated water. PBD-zirconia column was the least retentive for non-polar compounds and therefore required lower temperatures. This column seems to be the most favourable. However, using pure superheated

water, the efficiency of the columns from his study had to be improved. Polar compounds, such as phenol and resorcinol, were separated on PGC column but the peaks were found to be very tailing. With the PBD-zirconia column, the strong interactions of some analytes with active sites on the stationary phase also caused poor peak shape and unresolved peaks.

To improve peak tailing, Miller and Hawthorne [32] chromatographed seven alcohols using a temperature gradient, which was similar to the use of temperature programme in GC methods. By increasing the temperature from 120-150 °C, the resolution of the three last peaks of sec-, iso- and n-butanol were improved during a 10 min run. Burgess [36] compared the use of isothermal and temperature programme in a separation of paraben homologues. With isothermal 200 °C, a mixture of parabens was separated, giving 4 tailing peaks. The peaks were much improved when using temperature programme (initial temperature 150 °C held for 10 min, followed by ramping 20 °C min<sup>-1</sup> to 240 °C).

An increase in flow rate may improve the peak tailing in HPLC at ambient temperature but not in superheated water chromatography because of a differential temperatures. The reason of this was described by Burgess [36]. He observed that with PRLP-S column at 200 °C an increase in flow rate from 0.9 to 1.6 to 2.0 ml min<sup>-1</sup> caused a peak distortion of phenol which was considered to be probably due to a differential temperature between a cooler in coming mobile phase and the hot column and/or by a viscosity difference between an organic-aqueous sample solvent and the mobile phase. However, when the study was repeated, the same effects were not observed [115].

One of the ways to improve the chromatographic qualities in RP-HPLC is to introduce additives to the mobile phase. It was of interest to determine if a number of additives, such as buffers and ion-pair reagents, which are widely

---

used in aqueous-organic mobile phases to improve peaks shape and control ionisation, would work in a superheated water system. Some questions arose; for example if those additives could work with superheated water and improve the peak shape, if they were capable of controlling ionisation at elevated temperatures as efficiently as in reversed phase LC, if the separation still followed RP-HPLC at ambient temperature or they gave a different chromatographic separation. Therefore, in this chapter we report an examination of the effects of additives.

In a preliminary investigation of the coupling of a UV detector to superheated water, we utilised a conventional HPLC system, with a flow cell with a detection volume of 4  $\mu\text{l}$ . With the system in operation the temperature of eluent leaving the column was elevated and might affect the light path through the detection flow cell and result in an unstable baseline. A set of cooling fins was therefore attached to the tubing leading from the column to detector to cool the eluent. However, if the oven temperature was greater than 120  $^{\circ}\text{C}$  and the flow rate exceeded 1  $\text{ml min}^{-1}$ , there was still a temperature increase in the flow cell, resulting in noise in the detection, as the UV detector is partially thermal sensitive [45]. It was more apparently if a temperature programme was used, since the baseline drifted more with a higher temperature ramping than with a lower one. Hence, even with the cooling fins it is recommended not to operate a flow rate more than 1.0  $\text{ml min}^{-1}$ . In this work usually the cooling fins could disperse the heat well enough to cool down the mobile phase and give a sufficiently stable baseline at the recorder.

### 3.2 Unbuffered superheated water

The preliminary investigation was to study pure superheated water as a mobile phase without additives to separate the sulfanamide compounds. Sulfonamides, a generic name for derivatives of *p*-aminobenzenesulfonamide (sulfanilamide), are antibacterial compounds that have a wide range of antimicrobial activity against gram-positive and gram-negative bacteria [116]. They are pH-sensitive and UV absorbing compounds. These drugs have attracted considerable analytical interest over many years and a great number of papers have been published on methods of determination, including GC [117-119], TLC [120-122], SFC [123-124] and HPLC [122, 125-134]. In HPLC, various methods have been used to analyse sulfonamides in both normal phase [125] and reversed phase, with silica C<sub>18</sub> bonded [126-131], CN [127], and PS-DVB [132-134] columns. With C<sub>18</sub> columns the amount of methanol or acetonitrile in mobile phase ranged from 10-25%, whereas with PS-DVB column the amount was slightly higher (10-70%) [126-134]. For an isocratic run to give the best separation of 22 sulfonamides in a mixture an optimal modifier concentration in mobile phase was 16% methanol or 10% acetonitrile [128-129]. Recently new instrumental methods such as capillary zone electrophoresis (CZE) [135-137] and capillary electrophoresis (CE) [138] have also been employed to analyse the sulfonamides.

In the present work, a set of sulfonamides were initially prepared as single components to determine the optimum conditions that gave a good symmetrical peak in each case. At a water flow rate of 1.0 ml min<sup>-1</sup> and back pressure 30 Kg cm<sup>-2</sup>, the sulfonamide compounds could be separated isothermally at a range of temperatures (Table 3.1).



**Table 3.1** The retention time of sulfonamides at different temperature of superheated water.

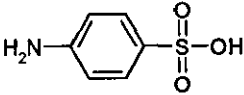
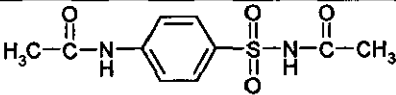
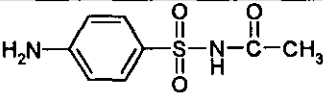
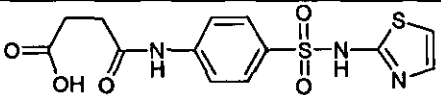
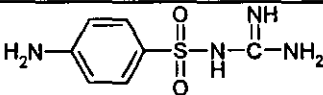
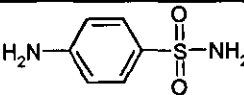
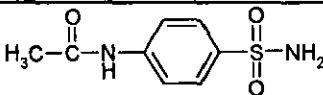
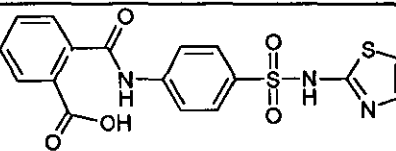
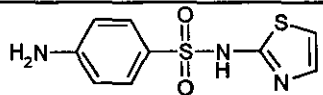
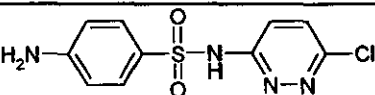
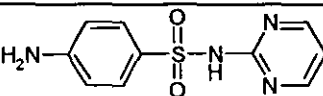
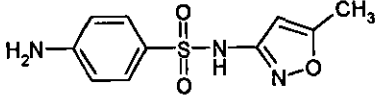
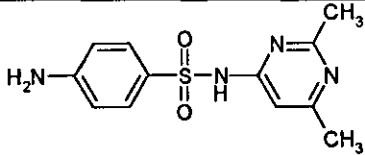
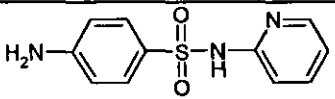
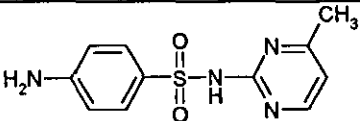
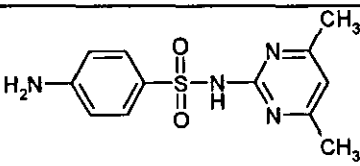
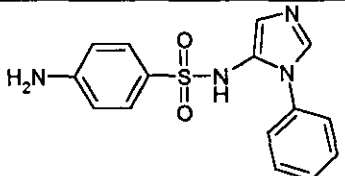
Compounds	Structure	Retention Time (min)		
		70 °C	150 °C	170 °C
Sulfanilic acid		1.0		
N <sup>1</sup> ,N <sup>4</sup> -diacetyl sulfanilamide		4.8		
Sulfacetamide		6.2		
Succinylsulfathiazole		9.3		
Sulfaguanidine		9.6		
Sulfanilamide		14.3	2.7, 8.3 (small)	
N <sup>4</sup> -acetyl sulfanilamide		29.5	3.4, 8.1 (small)	
Phthalylsulfathiazole (thalazole)			5.4	
Sulfathiazole			5.4	
Sulfachloropyridazine			5.5, 7.9 (small)	4.0
Sulfadiazine			5.9	

Table 3.1 (continued)

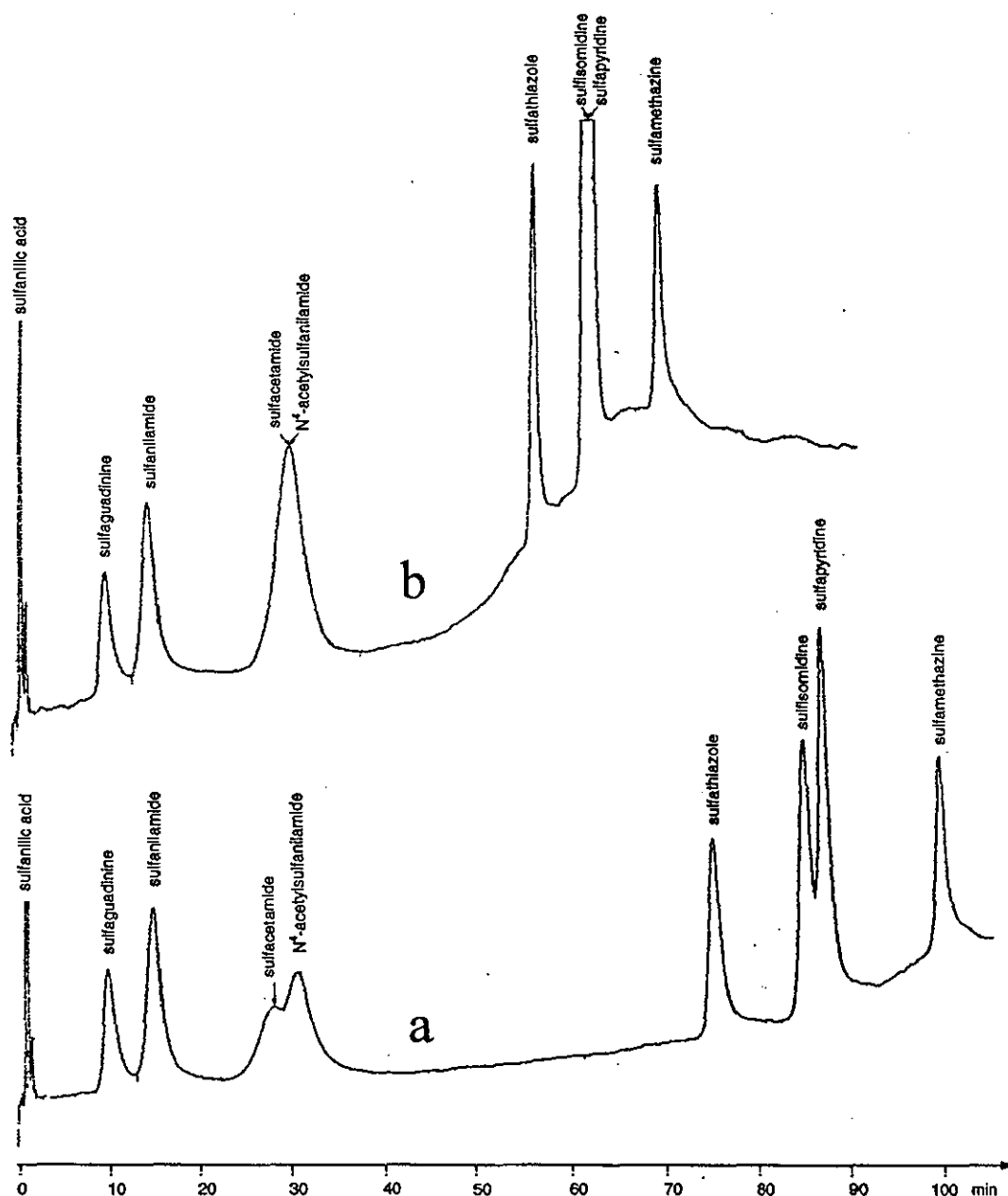
Compounds	Structure	Retention Time (min)		
		70 °C	150 °C	170 °C
Sulfamethoxazole			6.0	
Sulfisomidine			8.2	
Sulfapyridine			14.7	6.0
Sulfamerazine			15.2	
Sulfamethazine				18.3
Sulfaphenazole				19.3

As the conditions were varied to examine the optimal temperature to separate each sulfonamide, some compounds were readily eluted at a moderately low temperature (70 °C), for example, sulfanilic acid,  $N^1,N^4$ -diacetyl sulfanilamide, sulfacetamide, succinylsulfathiazole, sulfaguanidine and sulfanilamide. Whereas at 150 °C a number of compounds gave similar retention times, for example phthalylsulfathiazole (5.4 min), sulfathiazole (5.4 min), sulfachloropyridazine (5.5 min), sulfadiazine (5.9 min) and sulfamethoxazole (6.0 min). In spite of varying the temperature, the flow rate and the injection

volume, a mixture of these compounds could not be separated. At a higher temperature (170 °C) a only few sulfonamides were retained; sulfapyridine (6.0 min), sulfamethazine (18.3 min), and sulfaphenazole (19.3 min).

A number of sulfonamides, namely sulfanilic acid, sulfaguanidine, sulfanilamide, N<sup>4</sup>-acetylsulfanilamide, sulfacetamide, sulfathiazole, sulfisomidine, sulfapyridine, sulfamethazine, were selected to prepare a test mixture, which should be well resolved. Because they covered a range of elution temperatures, different temperature programmes were examined to separate the mixture of those nine sulfonamides from 70-190 °C. The results in Figure 3.1 showed that the baseline drift increased with the rate of ramping temperature. At the rate of 4 °C min<sup>-1</sup>, the sulfanilamide and N<sup>4</sup>-acetylsulfanilamide peaks were unresolved and gave only one peak, as did sulfisomidine and sulfapyridine. A better separation was obtained by using an increment of 2 °C min<sup>-1</sup>, in which the peaks of those pairs were only partially overlapped. An optimal rate 2 °C min<sup>-1</sup> was therefore selected which was enough to separate all components in the mixture. Although the increment of 1 °C min<sup>-1</sup> was possible in the instrument, the increase was too slow and it took a longer time to obtain a chromatogram.

However, as the experiment was repeated, we found that the separation pattern and retention time of these compounds were not consistent, in spite of operating the same programme conditions within the same day. It was suspected that this effect was a result of the uncontrolled pH of the water, since sulfonamides are pH-sensitive compounds. The use of a buffer in the mobile phase system to control ionisation was therefore considered.



**Figure 3.1** Chromatograms of a mixture of nine sulfonamides separated using pure superheated water chromatography.

**Conditions:** column, PRLP-S column, mobile phase, 100% water at flow rate  $1 \text{ ml min}^{-1}$ ; back pressure,  $30 \text{ kg cm}^{-2}$ ; detection, absorption wavelength,  $254 \text{ nm}$ ; oven temperature programmed at (a)  $70 \text{ }^\circ\text{C}$   $40 \text{ min}$ ,  $2 \text{ }^\circ\text{C min}^{-1}$ ,  $190 \text{ }^\circ\text{C inf}$ .

(b)  $70 \text{ }^\circ\text{C}$   $35 \text{ min}$ ,  $4 \text{ }^\circ\text{C min}^{-1}$ ,  $190 \text{ }^\circ\text{C inf}$ .

### 3.3 Buffered superheated water

Because of a decrease in the polarity of water as the temperature increases, if there were any inorganic salts present in the superheated water chromatographic system there was a real concern that they might precipitate. However, a solution of dipotassium hydrogen phosphate in water has been successfully utilised by Marshall *et al.* [139] at 100–400 °C. He reported that phosphates at extremely low concentration could be employed as corrosion inhibitors in a boiling vessel. However, their presence at high concentrations (10 – 63 wt%) can be very corrosive, as it was noticed that there was a rapid production of hydrogen gas at titanium-alloy vessels, a green colour at nickel and/or iron at stainless steel vessels and a gelatinous silica precipitate in Pyrex glass and silica tubes. Wofford *et al.* [140] also studied the titration of (0.025 m) boric acid with (0.2 m) KOH at high temperature (300–380 °C) and pressure (24.1 – 41.3 MPa) but there was no report of corrosion in the study, although a titanium titration cell with sapphire windows and titanium tubing were used. The titration of a strong acid and base, such as ( $5 \times 10^{-4}$  –  $10^{-2}$  M) sulfuric acid and (0.4465 M) ammonia, under sub- and supercritical water conditions at temperatures ranging from 200–400 °C and pressures from 3500–6000 psi were also investigated by Xiang *et al.* [141]. He found that at 380 °C and 5000 psi the system  $\text{H}_2\text{SO}_4 - \text{NH}_4 - \text{HSO}_4$  may be used as a buffer at  $\text{pH } 3.5 \pm 0.25$ . He also observed corrosion of a sapphire window that was more severe in alkaline solution ( $\text{pH} > 9$ ) than in acid or neutral solutions.

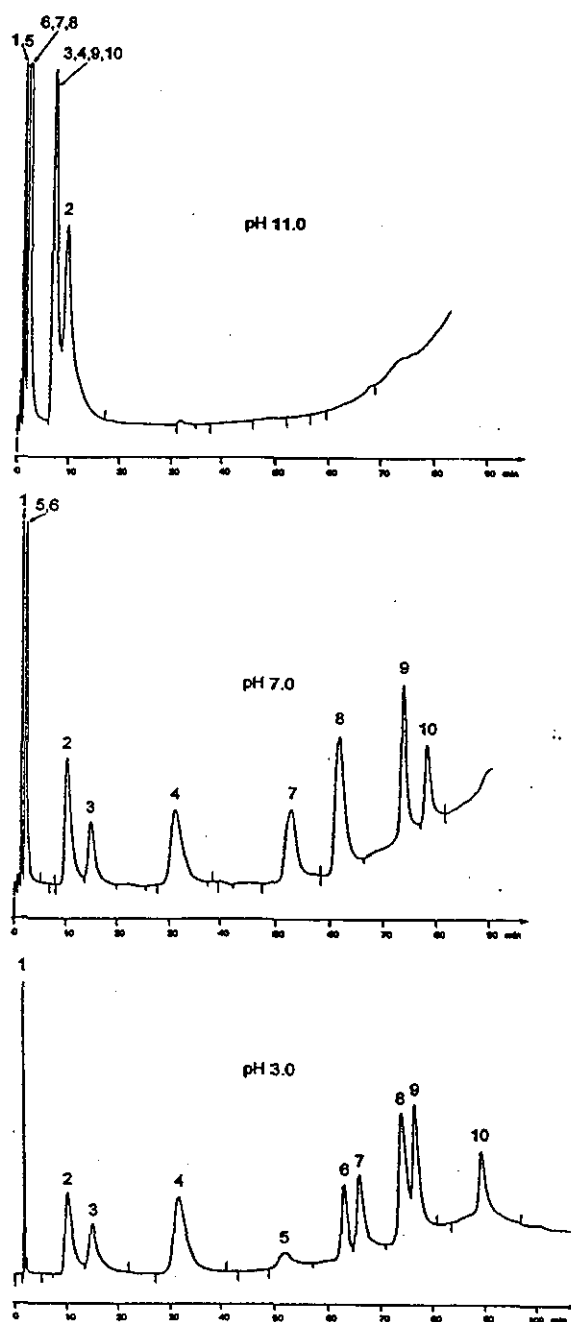
It was therefore expected that the phosphate-water buffer could be used in a superheated water chromatographic system and this could also be expanded to the use of other inorganic buffers as mobile phases in the system. In the present study inorganic buffers were thought to be preferable to organic buffers because some organic buffers might give rise to problems at elevated

temperature [142]. For example, bicarbonate/CO<sub>2</sub> buffers needed a closed system for equilibration. Several organic buffers, i.e. Tris, aliphatic amines, etc., have high temperature coefficients, thus, on raising the temperature the pHs of the buffers decrease. There was also a concern about the optimal concentration of inorganic buffer to be used. If the buffer concentration was too low, it would not be utilised to buffer the solution and if it was too high, it might cause corrosion in the hardware system.

### **3.3.1 Separation of sulfonamides in acid, neutral and basic buffered superheated water**

The mobile phase system was prepared using a low concentration (1-3 mM) of inorganic salts, sufficient to maintain the pH but low enough to prevent the precipitation and corrosion that might occur in the system if the phosphates were present at high concentration. As a result, chromatography was achieved without salt precipitation in the system.

Ten sulfonamides were prepared as a mixture and separated in acidic, neutral and basic buffers at pH 3.0, 7.0, and 11.0 prepared from phosphate salts (Figure 3.2 and Table 3.2).



**Figure 3.2** Chromatogram of a separation of 10 sulfonamides in phosphate buffer pH 3.0, 7.0 and 11.0. Conditions: column, 4.6 x 150 mm 5  $\mu$ m PRLP-S, mobile phase, 1 - 3 mM phosphate buffer at flow rate 1 ml min<sup>-1</sup>; oven temperature programmed at 70 °C 30 min, 2 °C min<sup>-1</sup>, 190 °C; back pressure, 30 kg cm<sup>-2</sup>; detection, absorption wavelength, 254 nm. Peaks: 1, sulfanilic acid; 2, sulfaguanidine; 3, sulfanilamide; 4, N<sup>4</sup>-acetylsulfanilamide, 5, sulfacetamide; 6, N<sup>1</sup>,N<sup>4</sup>-diacetylsulfanilamide; 7, sulfathiazole; 8, sulfisomidine; 9, sulfapyridine; 10, sulfamethazine

**Table 3.2** Retention times and factors (*k*) of 10 sulfonamides at different pH buffers

Compounds	Retention at pH					
	3.0		7.0		11.0	
	<i>t<sub>R</sub></i>	<i>k</i>	<i>t<sub>R</sub></i>	<i>k</i>	<i>t<sub>R</sub></i>	<i>k</i>
Sulfanilic acid	1.72	1.86	1.18	0.97	1.21, 2.18	1.02
Sulfaguanidine	9.97	15.62	10.15	15.92	9.77	15.28
Sulfanilamide	14.69	23.48	14.82	23.69	7.21	11.01
N <sup>4</sup> -acetylsulfanilamide	31.36	51.27	31.13	50.88	7.21	11.01
Sulfacetamide	51.72	85.19	1.96	2.26	1.21	1.02
N <sup>1</sup> ,N <sup>4</sup> -diacetylsulfanilamide	63.00	103.9	1.96	2.26	2.18	2.63
Sulfathiazole	65.94	108.9	53.30	87.83	1.94	2.23
Sulfisomidine	74.10	122.5	62.35	102.9	2.18	2.63
Sulfapyridine	76.66	126.7	74.61	123.3	7.21	11.01
Sulfamethazine	89.36	147.9	79.15	130.9	7.21	11.01

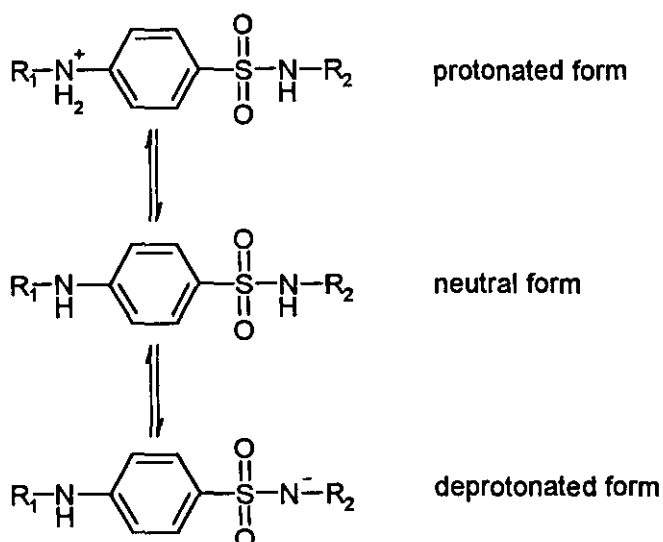
At pH 3.0, all ten sulfonamides were well separated and resolved with satisfactorily symmetrical peaks, except for sulfisomidine and sulfapyridine which slightly overlapped at 74.1 and 76.6 min. Changing the mobile phase buffer from acid (pH 3.0) to neutral (pH 7.0) altered the retention, order of elution and separation pattern. Some compounds changed retention markedly, for example sulfacetamide and N<sup>1</sup>,N<sup>4</sup>-diacetylsulfanilamide, which had been retained at 51.7 and 63.0 min in acid but were virtually unretained at neutral pH (the retention times were less than 2.0 min). A slight decrease in retention was found in sulfathiazole, sulfisomidine, sulfapyridine and sulfamethazine, whereas sulfanilic acid, sulfaguanidine, sulfanilamide and N<sup>4</sup>-acetylsulfanilamide remained unchanged. It should be noted that using buffer on a run to run daily basis, the retention times and chromatographic separation pattern of all sulfonamides were more consistent than using only



pure water. For example, at 70 °C the retention time of sulfanilamide was 15.14, 13.90 and 16.93 min within three consecutive runs when using pure water mobile phase but was 14.69, 14.82, 14.43 min when using buffer pH 7.0.

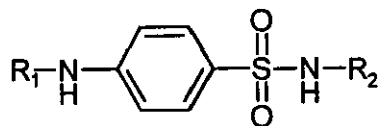
On changing the buffer to pH 11.0 the retentions of almost all of sulfonamides were greatly decreased. They were virtually unretained, poorly separated and were all rapidly eluted within 10 min. This phenomenon was possibly described by the primary pH effect over sulfonamides, according to  $pK_a$  of the compounds.

Because sulfonamides are amphoteric and have two dissociation equilibria as shown in Figure 3.3, changing the mobile phase to low pH causes protonation at the anilinium group and converts a neutral sulfonamide to be in a protonated form. Whereas changing the mobile phase to high pH results an ionisation of the sulfonamide nitrogen and transforms the neutral sulfonamide to be a deprotonated one. The dissociation constants and structures of the sulfonamides are given in Table 3.3. The  $pK_a$  of sulfanilic acid is 3.23 and the structure is given in Table 3.1.



**Figure 3.3** The association and dissociation of a sulfonamide in water.

**Table 3.3** Structure and  $pK_a$  of some sulfonamide compounds.  $pK_a$  data were obtained from references [136-137].



General structure in neutral form

Compounds	R <sub>1</sub>	R <sub>2</sub>	pK <sub>a1</sub>	pK <sub>a2</sub>
Sulfaguanidine	H		-	-
Sulfanilamide	H	H	2.36 <sup>[137]</sup>	10.43 <sup>[137]</sup>
N <sup>4</sup> -acetylsulfanilamide		H	-	-
Sulfacetamide	H		1.78 <sup>[137]</sup>	5.38 <sup>[137]</sup>
N <sup>1</sup> ,N <sup>4</sup> -diacetylsulfanilamide			-	-
Sulfathiazole	H		2.08 <sup>[136]</sup>	7.07 <sup>[136]</sup>
Sulfisomidine	H		2.68 <sup>[136]</sup>	7.26 <sup>[136]</sup>
Sulfapyridine	H		2.58 <sup>[137]</sup>	8.43 <sup>[137]</sup>
Sulfamethazine	H		2.36 <sup>[137]</sup>	7.37 <sup>[137]</sup>

At pH 3.0 each sulfonamide whose  $pK_{a1}$  is less than 3.0 and whose  $pK_{a2}$  is more than 5.0 would be in the neutral form. Therefore, these compounds should be strongly retained in the polymeric based column. The change of pH from 3.0 to 7.0 dramatically dropped the retention of the acidic sulfacetamide ( $pK_{a2} = 5.38$ ) and  $N^1, N^4$ -diacetylsulfanilamide. Although the  $pK_{a2}$  of  $N^1, N^4$ -diacetylsulfanilamide is not reported in the literature, it was presumably similar to that of sulfacetamide, as they contained the same  $-SO_2-NH-CO-CH_3$  functional group that dominates the  $pK_{a2}$  of sulfonamides. Sulfathiazole, sulfisomidine, and sulfamethazine whose  $pK_{a2}$ s are approximately 7 were partly deprotonated and were eluted faster than sulfapyridine whose  $pK_{a2} = 8.43$ . Meanwhile both sulfanilamide ( $pK_{a2} = 10.43$ ) and  $N^4$ -acetylsulfanilamide in which  $R_2$  is unsubstituted and presumably has a  $pK_{a2}$  at approximately 10, was in a neutral form and thus maintained their retention.

At pH 11.0, all of the sulfonamides were ionised; they were therefore only slightly retained in the column, resulting the drops in retention time. Nevertheless, there were two sulfonamides that did not change their retention in acid, neutral or basic circumstances. Those were sulfanilic acid and sulfaguanidine. Unfortunately, the  $pK_a$  of sulfaguanidine has not been reported. Sulfanilic acid is moderately acid and the  $pK_{a1}$  and  $pK_{a2}$  are very low, therefore it was totally ionised and deprotonated at pH less than 3.0. Hence, the sulfanilic acid was always rapidly eluted.

The elution orders of separated sulfonamides in each pH were found to be similar to those obtained by a conventional RP-HPLC method with PS-DVB columns at room temperature [132-133]. For example, with XAD-2 column and at pH 2.80 (which can be comparable to pH 3.0 in this work) Rotsch *et al.* [132] found that the elution order was sulfaguanidine<sup>(2)</sup>, sulfanilamide<sup>(3)</sup>, sulfacetamide<sup>(5)</sup>, sulfathiazole<sup>(7)</sup>, sulfapyridine<sup>(9)</sup>, and sulfamethazine<sup>(10)</sup>. At pH 6.73 (compare with pH 7.0 in this work) the elution order was sulfacetamide<sup>(5)</sup>,

sulfaguanidine<sup>(2)</sup>, sulfanilamide<sup>(3)</sup>, sulfathiazole<sup>(7)</sup>, sulfapyridine<sup>(9)</sup>, and sulfamethazine<sup>(10)\*</sup>. This result also agreed with a latter study by Lee *et al.* [133], with PRP-1 column at pH 3.1 he found the order of elution was sulfanilic acid<sup>(1)</sup>, sulfaguanidine<sup>(2)</sup>, sulfanilamide<sup>(3)</sup>, sulfathiazole<sup>(7)</sup>, and sulfamethazine<sup>(10)</sup>.

A recent study of the separation with a C<sub>18</sub> column and an isocratic run with 16% methanol - 84% 0.1 M phosphate buffer (pH 2.8), Ricci and Cross [128-129] reported an order of elution: sulfanilic acid<sup>(1)</sup>, sulfaguanidine<sup>(2)</sup>/sulfanilamide<sup>(3)</sup> (co-eluted), sulfacetamide<sup>(5)</sup>, sulfisomidine<sup>(8)</sup>, sulfathiazole<sup>(7)</sup>, sulfapyridine<sup>(9)</sup> and sulfamethazine<sup>(10)</sup>. Whilst with an isocratic 10% acetonitrile - 90% 0.001 M phosphate buffer at the same pH, they found that the elution order was sulfanilic acid<sup>(1)</sup>, sulfaguanidine<sup>(2)</sup>, sulfanilamide<sup>(3)</sup>, sulfisomidine<sup>(8)</sup>, sulfacetamide<sup>(5)</sup>, sulfathiazole<sup>(7)</sup>/sulfapyridine<sup>(9)</sup> (co-eluted), and sulfamethazine<sup>(10)</sup>. It is noticed that with the same pH but a different modifier sulfisomidine gave a different elution order. This is possibly due to the  $pK_{a1}$  of sulfisomidine (2.68) and the susceptibility of the compound to the pH of conditions. At pH 2.8 sulfisomidine was not entirely deprotonated, hence it was less retained in the column.

As the dissociation constant of water ( $pK_w$ ) is higher as the temperature is increased, the sulfonamide mixture might be being separated at different pH from ambient conditions or the dissociation of sulfonamides may have changed under superheated water conditions. Hence, it is of interest to investigate the dissociation constant of selected sulfonamides.

---

Sulfonamide<sup>(\*)</sup>: \* = the elution number that given to sulfonamide in Figure 3.2.

### 3.3.2 $pK_a$ Determinations of some sulfonamides in superheated water conditions

To examine the dissociation of sulfonamides across the temperature range from low to high, a number of sulfonamides were chosen on the basis that they were separated at different temperature and represented compounds whose  $pK_{a2}$  were acidic (sulfacetamide), neutral (sulfathiazole and sulfamethazine) and basic (sulfanilamide). The pH of the mobile phase was increased from 3.0 to 13.0 with increments of 0.5 using a range of buffers, phosphate, citrate, borate, carbonate, acetate, and the retention times and retention factors of the sulfonamides were recorded (Table 3.4). Although some sulfonamides could be separated over a range of temperature, there was a certain range of pH in which the retention changed dramatically. For example, the retention of sulfanilamide was greatly altered at a pH range of 8.0 - 12.0, but at pH 3.0 - 8.0 it was virtually constant at ca. 8.0 min when separated at 90 °C and at ca. 4.2 min when separated at 120 °C. The large retention change was a result of a change of neutral to deprotonated form.

Table 3.4 Retention time of sulfonamides at various pH

pH	Retention time (min)						
	Sulfacetamide		Sulfanilamide			Sulfathiazole	Sulfamethazine
	60 °C	90 °C	60 °C	90 °C	120 °C	120 °C	150 °C
3.0	-	22.30	-	7.90	4.24	26.23	50.00
3.5	-	25.30	-	-	-	26.28	-
4.0	-	26.60	-	-	-	26.01	49.94
4.5	-	22.84	-	8.15	4.19	25.02	-
5.0	-	18.21	-	8.50	4.30	24.91	46.25
5.5	-	8.57	-	7.97	4.19	22.88	38.79
6.0	-	3.23	-	8.00	4.16	12.70	26.55
6.5	-	2.09	-	8.17	4.21	9.58	25.16
7.0	-	1.54	21.29	7.89	4.00	5.08	14.18
7.5	-	1.41	-	-	4.13	2.59	6.61
8.0	1.68	-	21.34	-	4.00	2.10	4.31
8.5	-	-	-	-	-	-	-
9.0	-	-	18.85	-	-	1.29	2.54
9.5	1.23	-	17.82	-	-	-	2.32
10.0	1.14	-	15.98	-	-	-	2.02
10.5	1.10	-	13.91	-	-	-	-
11.0	1.13	-	9.81	-	-	-	1.54
11.5	1.25	-	5.31	-	-	-	-
12.0	1.37	-	3.14	-	-	-	-
12.5	1.55	-	2.18	-	-	-	-
13.0	-	-	1.60	-	-	-	-

In the range of pH that the retention changed, we calculated retention factors ( $k$ ) using the equation,  $k = (t_R - t_0)/t_0$ , where  $t_R$  = the retention time of the compound of interest, and  $t_0$  = the retention time of non-retained species. In this experiment, sodium nitrate was used and gave the retention time at ca. 1.29 min. The results (Table 3.4) were used to calculate the relationship between hydrogen ion concentration effect and retention factor (1) [115] by using the Solver function of Excel computer programme to model the non-linear least square relationship (see section 2.6).

$$k = \frac{k_0}{1 + \frac{K_a}{[H^+]}} + \frac{k_{-1}}{1 + \frac{[H^+]}{K_a}} \quad \dots\dots\dots(1)$$

Whereas,  $k$  = retention factor at a given hydrogen ion concentration,  $k_0$  = retention factor of the neutral species,  $k_{-1}$  = retention factor of the deprotonated species,  $K_a$  = ionisation constant, and  $[H^+]$  = hydrogen ion concentration.

The resulting equation was then used to calculate the predicted retention factors ( $k$ ) and the dissociation constant of each sulfonamide. All of the calculated values of retention factors, predicted retention factors and dissociation constants are shown in Table 3.5 - 3.8.

Table 3.5  $pK_a$  Determination of sulfacetamide ( $T = 90\text{ }^\circ\text{C}$ )

pH	$t_R$ (min)	Retention factor ( $k$ )			
		expt.	predicted	Difference	
3.0	22.30	16.29	19.50	-3.21	$t_0 = 1.29$
3.5	25.30	18.61	19.24	-0.63	
4.0	26.60	19.62	18.46	1.16	
4.5	22.84	16.71	16.36	0.35	
5.0	18.21	13.12	12.04	1.08	
5.5	8.81	5.83	6.59	-0.76	$k_0 = 19.62$
6.0	3.23	1.50	2.75	-1.25	$k_1 = 0.09$
6.5	2.09	0.62	1.02	-0.40	$k_1 * K_{a2} = 5.71 \times 10^{-7}$
7.0	1.54	0.19	0.39	-0.20	$K_{a2} = 6.34 \times 10^{-6}$
8.0	1.41	0.09	0.12	-0.03	<b><math>pK_{a2} = 5.20</math></b>

Table 3.6  $pK_a$  Determination of sulfanilamide ( $T = 60\text{ }^\circ\text{C}$ )

pH	$t_R$ (min)	Retention factor ( $k$ )			
		expt.	predicted	Difference	
7.0	21.29	15.50	15.54	-0.04	$t_0 = 1.29$
8.0	21.34	15.54	15.51	0.03	
9.0	18.85	13.61	15.24	-1.63	
9.5	17.82	12.81	14.64	-1.83	
10.0	15.98	11.39	13.02	-1.63	
10.5	13.91	9.78	9.67	0.11	
11.0	9.81	6.60	5.39	1.21	$k_0 = 15.54$
11.5	5.31	3.12	2.36	0.76	$k_1 = 0.24$
12.0	3.14	1.43	0.98	0.45	$k_1 * K_{a2} = 4.72 \times 10^{-12}$
12.5	2.18	0.69	0.48	0.21	$K_{a2} = 1.97 \times 10^{-11}$
13.0	1.60	0.24	0.32	-0.08	<b><math>pK_{a2} = 10.71</math></b>



Table 3.7  $pK_a$  Determination of sulfathiazole ( $T = 120\text{ }^\circ\text{C}$ )

pH	$t_R$ (min)	Retention factor ( $k$ )			
		expt.	predicted	Difference	
3.0	26.23	19.33	19.35	-0.02	$t_0 = 1.29$
3.5	26.28	19.37	19.32	0.05	
4.0	26.01	19.16	19.21	-0.05	
4.5	25.02	18.40	18.87	-0.47	
5.0	24.91	18.31	17.86	0.45	
5.5	22.88	16.67	15.31	1.36	
6.0	12.70	8.84	10.62	-1.78	
6.5	9.58	6.43	5.59	0.84	$k_0 = 19.37$
7.0	5.08	2.94	2.53	0.41	$k_1 = 0.60$
7.5	2.59	1.01	1.26	-0.25	$k_1 * K_{a2} = 5.24 \times 10^{-7}$
8.0	2.10	0.62	0.81	-0.19	$K_{a2} = 8.73 \times 10^{-7}$
9.0	1.29	0.00	0.62	-0.62	<b><math>pK_{a2} = 6.06</math></b>

Table 3.8  $pK_a$  Determination of sulfamethazine ( $T = 150\text{ }^\circ\text{C}$ )

pH	$t_R$ (min)	Retention factor ( $k$ )			
		expt.	predicted	Difference	
3.0	50.00	37.76	37.74	0.02	$t_0 = 1.29$
4.0	49.94	37.71	37.56	0.15	
5.0	46.25	34.85	35.88	-1.03	
5.5	38.79	29.07	32.38	-3.31	
6.0	26.55	19.58	24.78	-5.20	
6.5	25.16	18.50	14.26	4.24	
7.0	14.18	9.99	6.17	3.82	
7.5	6.61	4.12	2.31	1.81	
8.0	4.31	2.34	0.89	1.45	$k_0 = 37.76$
9.0	2.54	0.97	0.26	0.71	$k_{-1} = 0.19$
9.5	2.32	0.80	0.21	0.59	$k_{-1} * K_{a2} = 1 \times 10^{-7}$
10.0	2.02	0.57	0.20	0.37	$K_{a2} = 5.28 \times 10^{-7}$
11.0	1.54	0.19	0.19	0.00	<b><math>pK_{a2} = 6.28</math></b>

From Table 3.5-3.8, the  $pK_{a2}$  obtained from the experiment was determined to be 5.20 for sulfacetamide, 10.71 for sulfanilamide, 6.06 for sulfathiazole and 6.28 for sulfamethazine. A correlation between each sulfonamide is shown the predicted retention factors plotted against the whole range of pH in Figure 3.4. A solid line represents the extrapolation curve of the calculated retention factor obtained from the non-linear least square equation and each point represents the experimental  $k$  value. All of predicted curves fitted the experimental data set reasonably well but there is a slight deviation of the sulfanilamide data set from the predicted curve. At pH 3.0 - 4.0 the experimental data of sulfacetamide shows the decrease in retention which was possibly caused by a partial protonation of sulfacetamide at the pH range, as  $pK_{a1}$  of sulfacetamide = 1.78.

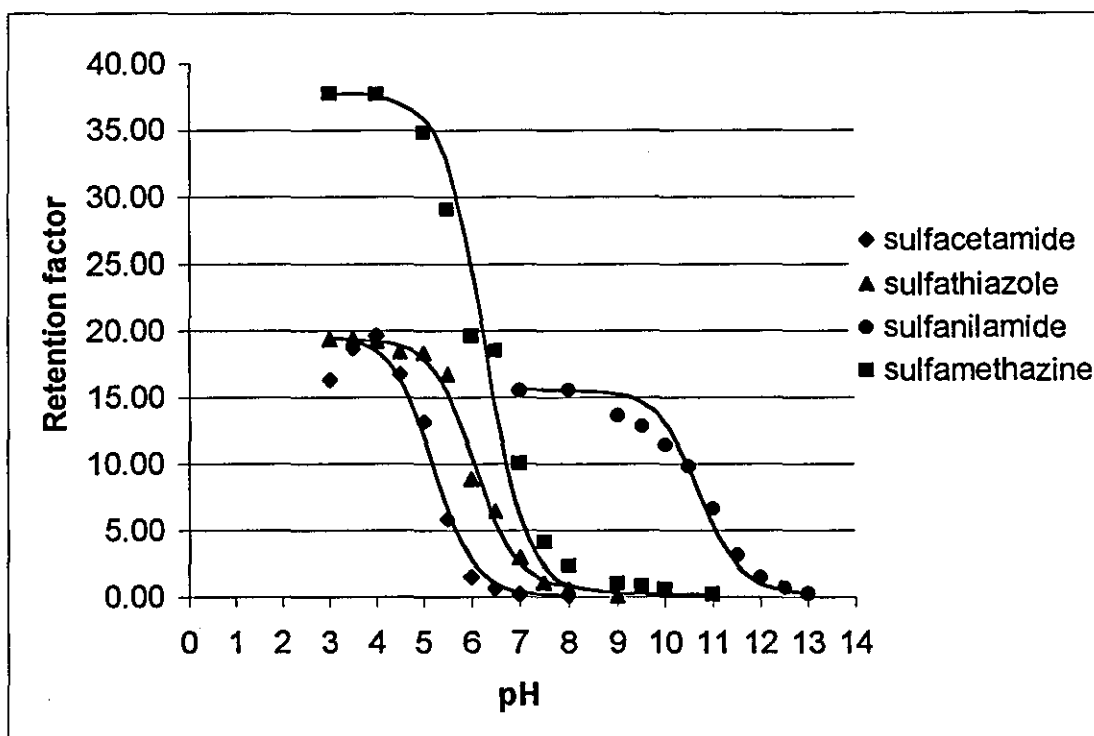


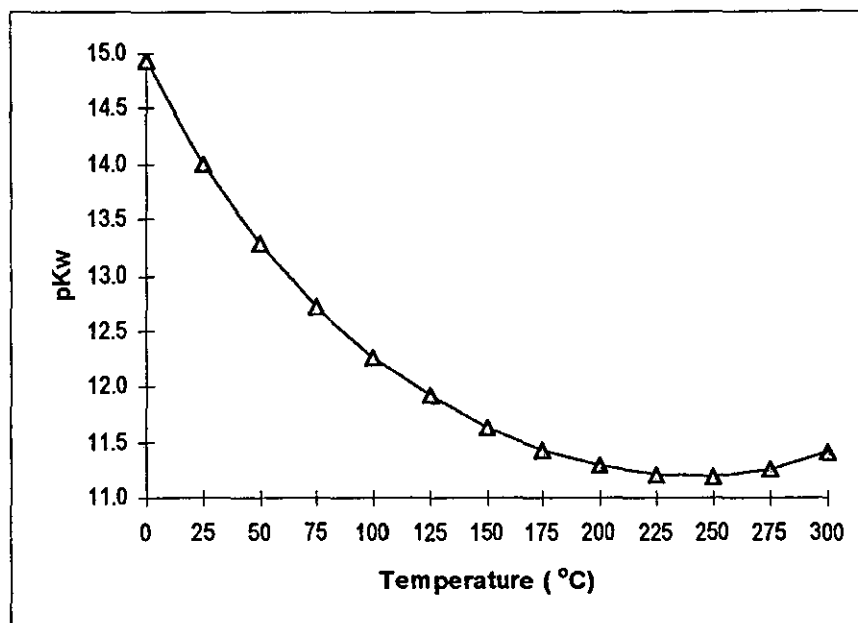
Figure 3.4 Comparison of experimental retention factors ( $k$ ) to the calculated values predicted by equation (1).

In Table 3.9, the calculated  $pK_{a2}$  of sulfonamides are compared with the reported  $pK_a$  values [136-137], and the difference between those values is also shown in the table. pH differences of  $\pm 0.2$  could arise from experimental variations but the pH difference of approximately 1.0 pH for sulfathiazole and sulfamethazine at the higher temperatures is too significant to be ignored. When relating the  $pK_a$  difference to the temperature used for separation, it is clearly noticed that as the temperature increased gradually from 60 °C to 150 °C, the  $pK_a$  difference of sulfonamide increased. In other word, as the temperature increases, the measured  $pK_a$  of the sulfonamides under superheated water conditions decreases, compare to the  $pK_a$  of the same compounds investigated under ambient conditions.

**Table 3.9** Comparison of  $pK_{a2}$  value calculated from the experiment and from the reference.

Compounds	Temperature (°C)	$pK_{a2}$ (exp.)	$pK_{a2}$ (ref.)	$pK_a$ difference
Sulfanilamide	60	10.71	10.43 <sup>[137]</sup>	+0.28
Sulfacetamide	90	5.20	5.38 <sup>[137]</sup>	-0.18
Sulfathiazole	120	6.06	7.07 <sup>[136]</sup>	-1.01
Sulfamethazine	150	6.28	7.37 <sup>[137]</sup>	-1.09

To describe this phenomenon we need to consider a few factors that possibly affect the change in  $pK_a$  determined under superheated buffered water conditions. The first factor is the pH of pure water, which also changes with temperature. As the temperature of water is raised, its dissociation increases, resulting in a decreased  $pK_w$ , as shown in Figure 3.5 [143]. In theory water dissociates into two species, hydronium and hydroxide ions, and the pH (which represents the hydronium ions concentration) of pure water at any temperature is equal to half of the  $pK_w$  at that temperature. For example, the pH of water at 150 °C is equal to 5.8 (half of  $pK_w$  (11.6) [143]) at the same temperature, as a result, the pH of water is also decreased as the temperature increases.



**Figure 3.5** Dissociation constant of water, presented in  $pK_w$ , as a function of temperature. (Data obtained from Ref.143)

The second factor is the dissociation and association at high temperature of the salts and acids added to formulate the buffers. Although we prepared the buffers to the exact pH at ambient temperature (ca. 22 °C), the dissociation of the acids and salts may be altered, as the temperature is raised. This effect was reported by Kryukov *et al.* [144], who studied the pH change of various buffers from low to high temperature. Some of the pH values in their study were summarised in Table 3.10. As the temperature was elevated from 25 °C to 150 °C, phosphate, phthalate, tartrate and tetraoxalate buffer were slightly increased in pH, except borax buffer of which pH was slightly decreased with temperature.

**Table 3.10** *pH experimental value and estimation value of various buffers in water from ambient temperature to 150 °C (Data obtained from reference [144].)*

T, °C	Tetraoxalate 0.05 M		Tartrate (sat'd at 25 °C)		Phthalate 0.05 M		KH <sub>2</sub> PO <sub>4</sub> + Na <sub>2</sub> HPO <sub>4</sub> 0.025 M		Borax 0.01 M	
	pH	pH <sub>lit.</sub>	pH	pH <sub>lit.</sub>	pH	pH <sub>lit.</sub>	pH	pH <sub>lit.</sub>	pH	pH <sub>lit.</sub>
25	1.67	1.68 <sup>†</sup>	3.57	3.56 <sup>†</sup>	4.01	4.01 <sup>†</sup>	6.86	6.86 <sup>†</sup>	9.16	9.18 <sup>†</sup>
60	1.72	1.73 <sup>†</sup>	3.57	3.57 <sup>†</sup>	4.09	4.10 <sup>†</sup>	6.83	6.84 <sup>†</sup>	8.93	8.96 <sup>†</sup>
90	1.80	1.80 <sup>†</sup>	3.67	3.65 <sup>†</sup>	4.21	4.20 <sup>†</sup>	6.90	6.88 <sup>†</sup>	8.83	8.85 <sup>†</sup>
100	1.82	-	3.69	3.68 <sup>*</sup>	4.24	-	6.92	6.88 <sup>*</sup>	8.81	8.82 <sup>*</sup>
125	1.90	-	3.79	3.80 <sup>*</sup>	4.37	-	6.96	6.92 <sup>*</sup>	8.73	8.75 <sup>*</sup>
150	-	-	3.92	3.95 <sup>*</sup>	4.50	-	7.08	7.04 <sup>*</sup>	8.66	8.65 <sup>*</sup>

† R. G. Bates. *Electrometric pH determination*. N. Y., 1954.

\* M. Le Peintre. *Bull. Coc. electriciens franc.*, 1, 9, 584 (1960).

As a result, if we considered solely the pH of the buffer it should give only a minor effect in the  $pK_a$  shift of sulfonamides. Any difference in the shift in  $pK_a$  could be mainly due to the dissociation of sulfonamides themselves at high temperature. The higher the temperature, the more dissociated is the sulfonamide. In addition, these results supported the theory that the dissociation of organic compounds varies with temperature [145]. The decrease in  $pK_a$  of sulfonamides with temperature in this study was in agreement with a decrease in  $pK_a$  of sulfanilic acid and its isomers (Table 3.11) [146]. From 0 to 50 °C, the decreases in  $pK_{a2}$  of aniline-2-sulfonic acid, aniline-3-sulfonic acid and aniline-4-sulfonic acid (or sulfanilic acid) were found to be 0.3, 0.6 and 0.5 pH-unit. The similar decrease was confirmed by

an investigation in nitrogenous bases (including alkylamines, aniline and pyridine) (Table 3.12), however, in this case the temperature change caused only a small effect to those bases [145]. Thermodynamically, we could say that the dissociation of sulfonamides in water is an endothermic reaction, since the raised temperature caused more dissociated species [147].

It should be noted that after a prolonged use of various buffers in the present system, no severe corrosion was noticed, except a slight green colour at the top of the column.

**Table 3.11**  $pK_{a2}$  of sulfanilic acid and its isomers at 0-50 °C [146]

$pK_{a2}$	Aniline-2-sulfonic acid	Aniline-3-sulfonic acid	Aniline-4-sulfonic acid (Sulfanilic acid)
0	2.63	4.07	3.52
5	2.59	4.00	3.46
10	2.55	3.93	3.40
15	2.52	3.86	3.34
20	2.49	3.80	3.28
25	2.46	3.73	3.23
30	2.43	3.67	3.17
35	2.40	3.62	3.12
40	2.38	3.57	3.08
45	2.35	3.51	3.03
50	2.33	3.46	2.99

**Table 3.12** Temperature coefficients for nitrogenous bases between 0 and 40 °C [145]

<i>If the <math>pK_a</math> is</i>	<i>Subtract for each °C rise</i>	<i>If the <math>pK_a</math> is</i>	<i>Subtract for each °C rise</i>
3.3	0.011	6.6	0.017
4.2	0.013	7.5	0.018
4.6	0.014	9.0	0.020
5.0	0.015	10.0	0.021
5.8	0.016	11.0	0.022

### 3.4 Ion-pair chromatography in superheated water

Some organic compounds are ionised in water and then, when chromatographed, they are not retained on a reversed phase column. One of many methods to analyse mixtures of these compounds is ion-pair RP-HPLC [148-149], in this method the analyte forms a complex with a counterion (from an ion-pairing reagent) or makes a cluster to neutralise the charge of the analyte. Reversed phase ion-pair chromatography has been applied to pharmaceuticals [150-154], amino acids [155], nucleotides [156], alkaloids [157], food additives [158], vitamins [159], etc.

When pure superheated water was tried to separate some of those organic compounds, such as dansyl amino acids, the resolution was very poor and chromatographic result was unfavourable. It is therefore of interest to determine if ion-pair superheated water without an organic solvent can be used as a mobile phase to separate those compounds and improve the resolution. Dansyl-glycine, dansyl-valine and dansyl-leucine were chosen as the test mixture. Dansyl amino acids are derivatised to enhance their



sensitivity for fluorescence detection and have been separated previously by ion-pair RP-HPLC [155, 160-161].

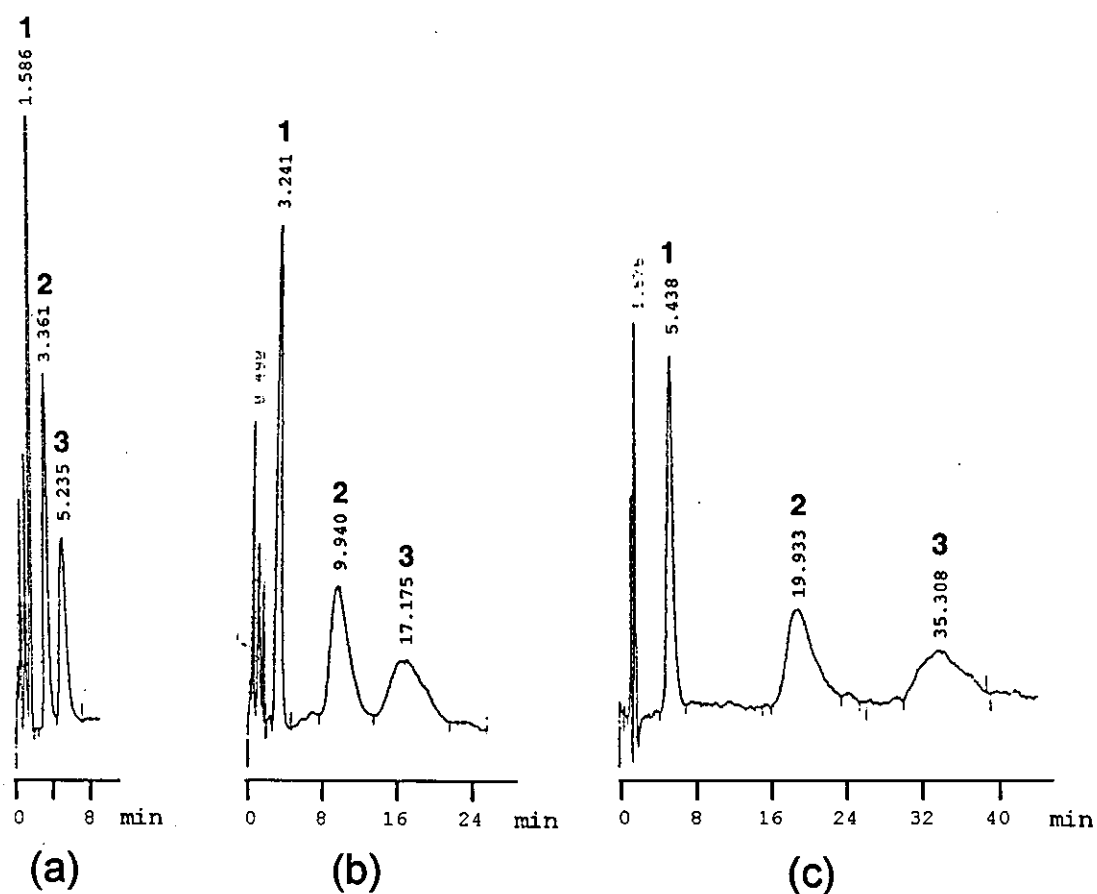
In this study the ion pairing mobile phase was prepared at the lowest possible concentrations of ion-pairing reagent, tetrabutylammonium bromide, and buffer sufficient to maintain the conditions. To investigate the separation effect in superheated water conditions, the concentration of the ion-pairing reagent was varied in a range of 0.0, 0.5, 1.0 mM. Since the ion-pair reagent caused bubbles in the pump and to eliminate this problem, a guard column replaced the filter.

It is clearly seen in Figure 3.6 that with or without the ion-pair reagent each peak was well separated and appeared in the order of increasing carbon number of the side chain of the amino acids. The retention order seemed to follow that of the ion-pair reversed-phase chromatography of dansyl amino acids studied by Grego and Hearn [161]. On a  $\mu$ Bondapak-alkylphenyl column with a gradient elution from 25-65% acetonitrile-water with 2 mM dodecylamine, 15 mM orthophosphoric acid, they found the elution order: dansyl-glycine, dansyl-valine, and dansyl-leucine.

On increasing the concentration of tetrabutylammonium bromide from 0.0 to 0.05 to 1.0 mM (Figure 3.6 a-c), the retention in superheated water increased proportionally to the concentration of the ion-pair reagent. This result also agreed with the effect in conventional ion-pair RP-HPLC that an increase in counterion concentration increases retention factors [149].

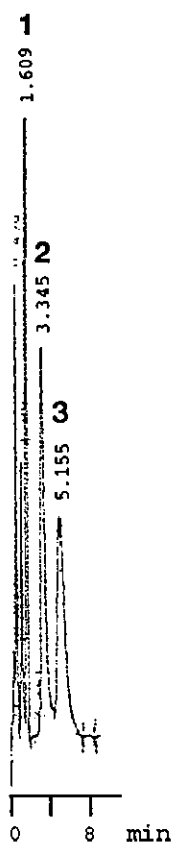
The effect of the chain length of the counterion was also studied; tetramethylammonium bromide replaced tetrabutylammonium bromide. The retention of all the components in the mixture decreased dramatically (Figure 3.7). For example dansyl leucine which gave a retention time at 35.31 min

dropped to 5.15 min when changing the counterion from tetrabutyl- to tetramethyl- ammonium ion. This effect was due to a decrease in the lipophilic moiety of the counterion, leading to less interaction with the non-polar stationary phase and corresponded to the effects which arise in a conventional ion-pair method [148]



**Figure 3.6** The chromatogram of separation of dansyl amino acid mixture in phosphate buffer pH 7.0 with 0.0 mM (a), 0.5 mM (b), and 1.0 mM (c) tetrabutylammonium bromide as ion-pair buffered superheated water. Conditions: column, 4.6 x 150 mm 5  $\mu$ m PRLP-S, mobile phase flow rate 1 ml min<sup>-1</sup>; oven temperature, 190 °C; detection, absorption wavelength, 254 nm

**Peaks:** 1, dansyl-glycine; 2, dansyl-valine; and 3, dansyl-leucine.



**Figure 3.7** *The chromatogram of separation of dansyl amino acid mixture in 1.0 mM tetramethylammonium bromide in phosphate buffer pH 7.0. Chromatographic conditions and peaks are as in Figure 3.6.*

It should be noted that after a prolong use of the Novapak C18 column, a dramatic decrease in retention was observed when using ion-pairing mobile phase more than that when using non-ion-pairing mobile phase. This could be a result of the collapse of the stationary phase due to the higher ionic strength of the mobile phase with ion-pair reagent than without ion-pair reagent. On increasing the concentration of ion-pairing reagent, the column was likely to cause more collapse. Burgess [36] explained that a temporary collapse was caused by an “unwetting” of the hydrophobic surface by water and this can be recovered, but a collapse caused by a dissolution of the silica based material was a permanent damage.

### 3.5 Summary

In initial studies we coupled a UV detector with the superheated water chromatographic system and observed the operation of the system. The detector was found to be thermally sensitive, as it exhibited a baseline drift when temperature was raised quickly. A set of cooling fins was utilised to cool down the mobile phase provided that the flow rate did not exceed  $1.0 \text{ ml min}^{-1}$  when using high temperature. Either pure water or buffer could be employed as the mobile phase but more consistency in retention and separation pattern were found when using the buffer. The use of many buffers were allowed but at low concentration in order to prevent corrosion arising in the system. However, inorganic buffers were preferable, as organic buffers possess high temperature coefficients. In addition, no severe damage of the hardware system was noticed when using buffered superheated water.

Under superheated water conditions with a low buffer concentration of 1-3 mM, the retention of sulfonamides changed with temperature and primarily with pH. The elution order of sulfonamides at pH 3.0 (acid), 7.0 (neutral) and 11.0 (alkali) followed conventional RP-HPLC at ambient conditions. The retention change of sulfonamides with pH was due to their dissociation constants. The  $pK_a$  of some sulfonamides were then examined at high temperature and compared the result at ambient condition, resulting a more understanding in a dissociation of sulfonamide that increased as temperature increased.

Not only pure buffer but ion-pair reagents with buffer could be used as additives for superheated water mobile phase. Because they caused bubbles in the pump and to eliminate this problem, the guard column was needed to replace the filter. For silica based column such as Novapak C18, the mobile phase seemed to cause a permanent collapse in the column but a similar

damage was not found when the polymeric column was employed. Using the ion-pair superheated water mobile phase, a series of dansyl amino acids were eluted in the order: dansyl-glycine, -valine and -leucine. The result showed an agreement with a separation by conventional ion-pair RP-HPLC method.

---

---

## Chapter 4

---

---

# Fluorescence Detection

### 4.1 Introduction

Fluorescence detection has been utilised successfully as a detector in liquid chromatography for decades [46] and the system has been used to analyse samples from various sources, including pharmaceuticals, agrochemical, and the environment. In this decade recently developed chromatographic techniques, such as SFC [47, 63-64], CE [162-165], CEC [165-167], have also employed fluorescence detection. Hence, the use of fluorescence detector for superheated water chromatography should be possible. As both UV and fluorescence detectors are non-destructive, those two detectors can be connected subsequently to other detector(s).

Because organic compounds give fluorescence at specific excitation and emission wavelength, a fluorescence detector is considered to be a highly selective detector [168]. The response of fluorescence detector is thermally sensitive and the fluorescence intensity may be reduced by heat. In our

configuration, the fluorescence detector was placed after the UV detector (section 2.2.4 and Figure 2.1). The heat from the eluent from the column (if any remained after the cooling fins) should be transferred to the environment and UV flow cell, before arriving the fluorescence flow cell

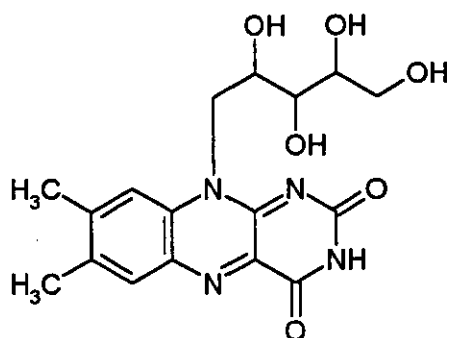
Unlike the coupling of SFC to fluorescence detection where there was a problem in keeping the temperature and pressure of the flow cell above the supercritical point or (at least retaining the eluent in the liquid state) [61-62], detection in superheated water can be carried out under ambient conditions. In our investigation, a number of fluorescent organic compounds typically analysed by LC-fluorescence spectroscopy were examined.

## 4.2 Separation of vitamins

The B group vitamins (riboflavin: B1, thiamine: B2 and pyridoxine: B6) was investigated initially as they are soluble or slightly soluble in water and give fluorescence, except vitamin B12 (cobalamine) which gives very little fluorescence. Some B vitamins are not stable in water at high temperature [170, 179-180]; for example thiamine may be oxidised and this is investigated in more detail in later chapters (see section 4.1.2 and 6.4).

### 4.2.1 Separation of riboflavin

Riboflavin (Figure 4.1) is a naturally fluorescence vitamin which functions in the body in the form of a coenzyme [169]. A lack of riboflavin caused humans to suffer from cracking at the mouth corners, to develop a shark like skin and a magenta coloured tongue [170]. Pure riboflavin is a yellow coloured solid soluble in alkaline pH but slightly soluble in ethanol and water. Only 1 gram of riboflavin is soluble in 3000-15,000 ml of water [171]. Light and alkali can decompose riboflavin [170].

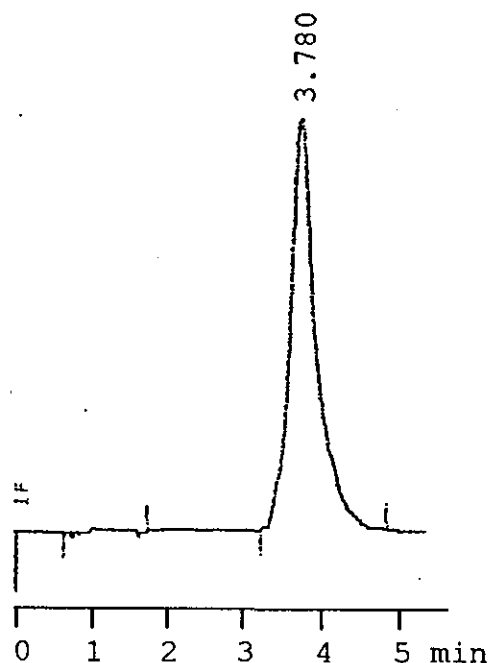


**Figure 4.1** Structure of vitamin B<sub>2</sub> (riboflavin)

Separation of riboflavin by reversed-phase HPLC with isocratic [172-173] or gradient elution [174-176] on ODS columns has been reported. With isocratic elution, the use of acetonitrile 13-25% in the mobile phase has been utilised at pH 2.7-4.0. Using superheated water mobile phase on PRLP-S column, we expected riboflavin to be more retentive.

Riboflavin was initially studied using the wavelength maxima for excitation and emission, which have been reported at 435 and 530 nm, respectively [177]. A riboflavin solution was prepared and chromatographed at 200 °C on PRLP-S column with a flow rate of 1.0 ml min<sup>-1</sup> (Figure 4.2) using a system (Figure 2.1) in which a fluorescence detector was added after the UV detector. This system gave a symmetrical fluorescence peak at 3.78 min with a very smooth background.





**Figure 4.2** Chromatogram of superheated water chromatography with fluorescence detection of  $5 \mu\text{l}$   $0.05 \text{ mg ml}^{-1}$  riboflavin, corresponding to  $0.25 \mu\text{g}$ . Conditions: column, PRLP-S  $5 \mu\text{m}$ ; mobile phase, deionised water; flow rate,  $1.0 \text{ ml min}^{-1}$ ; temperature,  $200 \text{ }^\circ\text{C}$ ; back pressure,  $15 \text{ kg cm}^{-2}$ ; detection, excitation wavelength,  $450 \text{ nm}$ , emission wavelength,  $530 \text{ nm}$ .

A number of riboflavin concentrations close to the detection limit were prepared and chromatographed to obtain the peak areas, which were averaged (Table 4.1). The responses were plotted with the mass of riboflavin on column (Figure 4.2), obtaining a linear relationship with a correlation 0.9899.

To find the limit of detection,  $5 \mu\text{l}$  of a very low concentration of riboflavin  $0.00048 \text{ mg ml}^{-1}$  (equivalent to  $2.4 \text{ ng}$  per injection) was chromatographed 10 times, then an average peak area, standard deviation (SD) and 3SD were calculated as shown in Table 4.2. By substitution the 3SD, slope ( $m$ ) and

intercept value into the equation,  $y - y_B = 3SD$ , whilst  $y$  is a signal correlated to the true detection limit and  $y_B$  is a signal correlated to the concentration of blank (or intercept in this case), and the equation  $y = mx$ , the detection limit ( $x$ ) was determined to be 3.6 ng. This detection limit was approximately 7 times higher than the LOD (0.5 ng) found for a conventional RP-HPLC method with a Spherisorb ODS column using 0.1 M phosphate buffer (pH 4) - acetonitrile (87:13) mobile phase, with the same detector ( $\lambda_{ex} = 466$  and  $\lambda_{em} = 524$  nm) [173], although the conventional method gave a sharp riboflavin peak at the longer retention time, 6.0 min.

**Table 4.1** Peak area of riboflavin mass range 4.8 – 24 ng on column detected by superheated water – fluorescence detection

Mass (ng)	4.8	9.6	14.4	19.2	24
Peak area	101652	172423	256128	305111	411719
	86478	171680	296278	295149	394409
	79281	142559	248575	296881	380507
	111946				
Average	94839	162221	266994	299047	395545

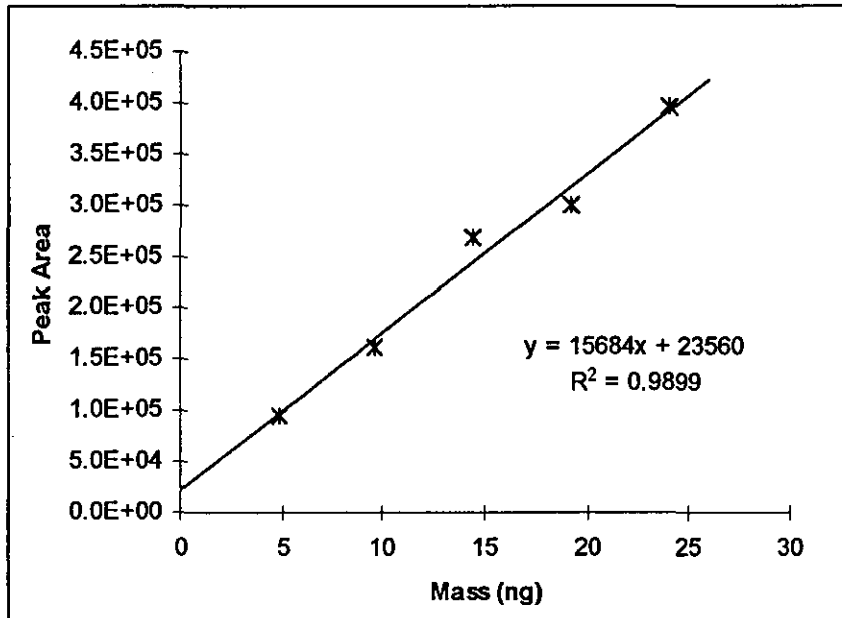


Figure 4.3 Riboflavin 4.8 – 24 ng on column plotted against peak area.

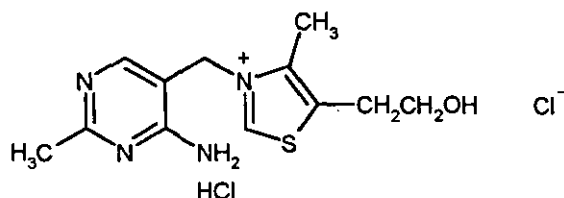
Table 4.2 Peak area of multiple injection of 2.4 ng riboflavin.

Peak area of 2.4 ng riboflavin on column	
57290	28571
30684	45697
28791	40457
36644	33282
40818	58573
Mean = 40081	
SD = 10937	
3SD = 32812	
LOD = 3.6 ng	

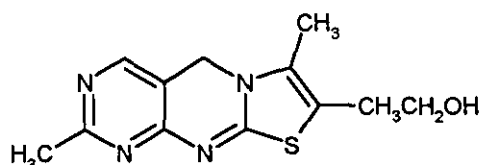
## 4.2.2 Separation of thiamine

**Vitamin B<sub>1</sub> (Thiamine)** acts as a coenzyme in carbohydrate metabolism [178]. Thiamine deficiency in humans causes beriberi, resulting loss of deep tendon reflexes, abnormal sensitivity of the skin, muscular pain and weakness, mental confusion and, in severe cases, cardiac failure [170].

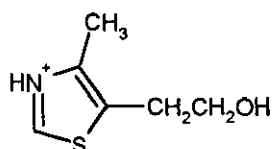
Thiamine hydrochloride (Figure 4.4) is hygroscopic and has a solubility in water of 1 g ml<sup>-1</sup> [171, 178]. Thiamine structure contains pyrimidine and thiazole rings linked with a methylene bridge. It decomposes in aqueous solution at pH > 5.5 or on heat, generating a degradation product 4-methyl-5-thiazoleethanol (Figure 4.4) [179]. Thiamine is easily oxidised to the tricyclic structure thiochrome, a strongly fluorescent compound [179-180].



Thiamine hydrochloride



Thiochrome



4-methyl-5-thiazoleethanol

**Figure 4.4** Structures of thiamine hydrochloride, thiochrome and 4-methyl-5-thiazoleethanol

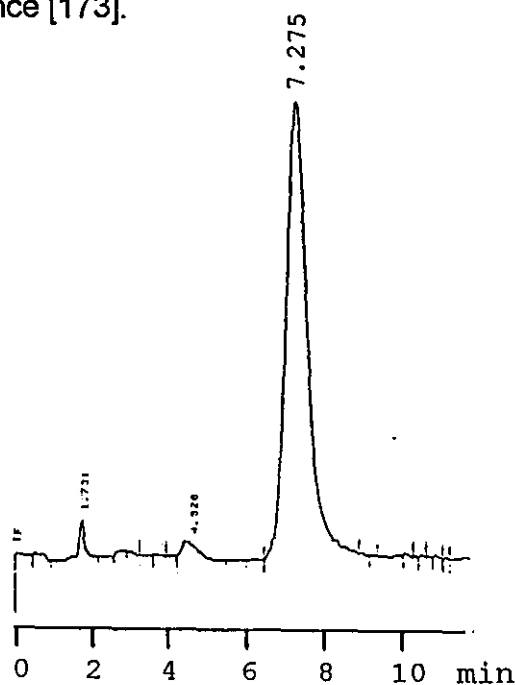
A preliminary study of thiamine hydrochloride was undertaken to investigate the fluorescence spectra, and the optimal excitation and emission wavelengths were found to be 365 and 430 nm which corresponded to literature report [181], although the UV absorption spectrum in our measurement indicated a maximum absorption at 243 nm. Thiamine hydrochloride solution was chromatographed under the conditions given in Figure 4.5 and was monitored by both UV and fluorescence detector. The resulting thiamine peak in the UV response showed a retention time at ca. 4.2 min but the fluorescence detector showed a peak with a retention time of ca. 7.0 min. The retention time difference between the peaks from two detectors was too great to assume that they were of the peaks of the same compound as the time lapse between those two detectors should be very small (6-7 sec or ca. 0.1 min). It appeared that either a partial oxidation of thiamine to thiochrome or a degradation to 4-methyl-5-thiazoleethanol was possibly occurring.

We carried out a few experiments to examine if oxidation of thiamine to thiochrome occurred, for example using the mobile phase with and without purging with N<sub>2</sub> gas. If oxygen present in the mobile phase had caused the oxidation of thiamine, we would expect the sample eluted with mobile phase without purging with N<sub>2</sub> gas to give a bigger peak than with purging N<sub>2</sub>. The results, however, were opposite. With the same concentration of thiamine sample on-column, the peak with purging N<sub>2</sub> was 3-4 times bigger than without purging N<sub>2</sub>. This was possible due to the presence of oxygen in the mobile phase. As oxygen can quench fluorescence, purging with N<sub>2</sub> could remove the oxygen therefore the fluorescence intensity was higher. We therefore tried the effect of oxidising thiamine to thiochrome.

In a conventional reversed-phase HPLC method, the determination of thiamine by oxidation to thiochrome prior to column injection has been studied [182-183]. The former method [182] needed up to 30% methanol in

the buffered mobile phase to elute thiochrome from a Polygosil 60 C18 column, whereas the later method [183] used 30% acetonitrile in phosphate buffer pH 7.0 as the mobile phase on Spherisorb C-8 column. We expected the same performance could be achieved by using superheated water without buffer and organic solvent and with the same detection method.

Oxidation of the thiamine sample by potassium ferricyanide followed by a solvent extraction [181] and subsequently injection of the oxidised thiamine resulted in a single peak ascribed to thiochrome at retention time 7.27 min, which could be seen only in a fluorescence chromatogram (Figure 4.5). We concluded that initially thiochrome had probably been a significant impurity in the thiamine sample. Even small amount of thiochrome present in a sample can give high fluorescence [173].



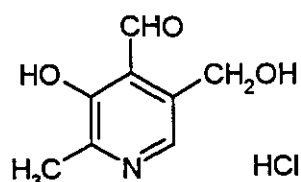
**Figure 4.5** Chromatogram of superheated water chromatography-fluorescence detection of oxidised thiamine (thiochrome). Conditions: column, PRLP-S 5  $\mu\text{m}$ ; mobile phase, deionised water; flow rate, 1.0  $\text{ml min}^{-1}$ ; temperature, 190  $^{\circ}\text{C}$ ; back pressure, 15  $\text{kg cm}^{-2}$ ; detection, excitation wavelength, 365 nm, emission wavelength, 430 nm.

Thiamine and its degradation product was further investigated using a hyphenated technique by coupling the superheated water chromatographic system to NMR and MS, yielding more information that could explain what was happening in the superheated water system (see section 6.4).

### 4.2.3 Separation of pyridoxine

**Vitamin B<sub>6</sub> (Pyridoxine)** (Figure 4.6) takes part in the metabolism of amino acids [178]. The active co-enzymes are in the form of pyridoxal-5-phosphate and pyridoxamine-5-phosphate. Deficiency symptoms in pyridoxine are similar to lack of riboflavin in humans [170].

One gram of pyridoxine hydrochloride is soluble in 4.5 ml water, giving a fluorescent solution [171]. Pyridoxine HCl is more stable when present in an acidic solution but the stability was reduced when it is exposed to light, like riboflavin [179].

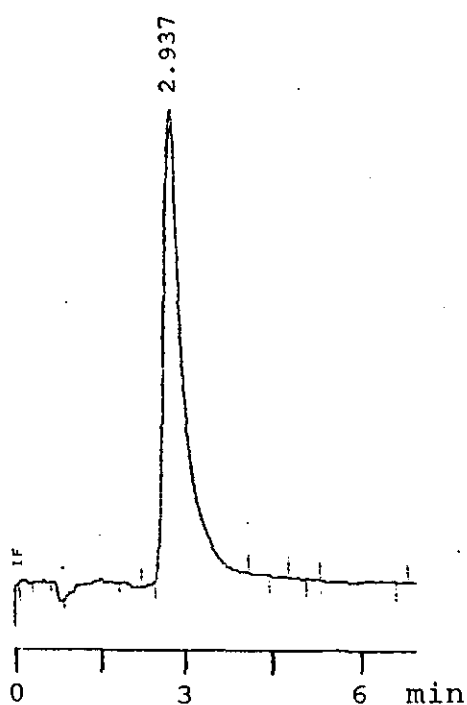


**Figure 4.6** Structure of pyridoxine hydrochloride

The determination of pyridoxine in foods and feeds has been studied previously utilising an ODS Hypersil column with a mobile phase of 0.1 M  $\text{KH}_2\text{PO}_4$  at pH 2.15 containing 3% methanol and 1.25 mM 1-octanesulfonic acid [184]. We expected pyridoxal hydrochloride would be much more retained on the PRLP-S polymeric column with pure water mobile phase at ambient temperature. The column temperature in superheated water system

needed to be raised up to 180 °C and gave a slightly tailing peak at 2.93 min (Figure 4.7).

It was noticed that all of the vitamins B had been separated using the PRLP-S column with the temperature between 180-200 °C. This corresponds to the dielectric constant of ca. 34-38 reported by Arkelof *et al.* [3] and corresponded to a 80-90% methanol-water mixture [185].

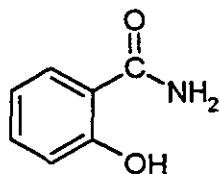


**Figure 4.7** Chromatogram of superheated water chromatography-fluorescence detection of 5  $\mu\text{l}$  0.001% pyridoxal hydrochloride, corresponding to 0.05  $\mu\text{g}$ . Conditions: column, PRLP-S 5  $\mu\text{m}$ ; mobile phase, deionised water; flow rate, 1.0  $\text{ml min}^{-1}$ ; temperature, 180 °C; back pressure, 15  $\text{kg cm}^{-2}$ ; detection, excitation wavelength, 317 nm, emission wavelength, 376 nm.



### 4.3 Separation of aspirin, salicylamide and quinine

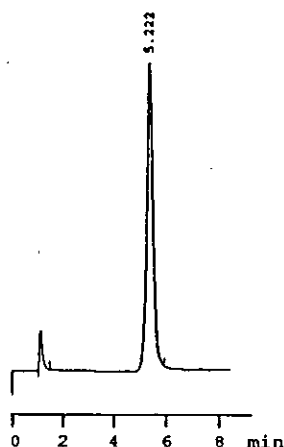
**Salicylamide** (Figure 4.8) is an analgesic, antipyretic and anti-inflammatory drug, which has similar effects to any other drugs in the salicylate group [186]. The most widely prescribed agent in these groups is aspirin (acetylsalicylic acid). Salicylamide gives not only effects similar to aspirin but sedative and hypotensive effects also [187]. Salicylamide is very soluble in alcohol, slightly in water, but it gives fluorescence in both media at excitation and emission wavelength 300 and 430 nm, respectively.



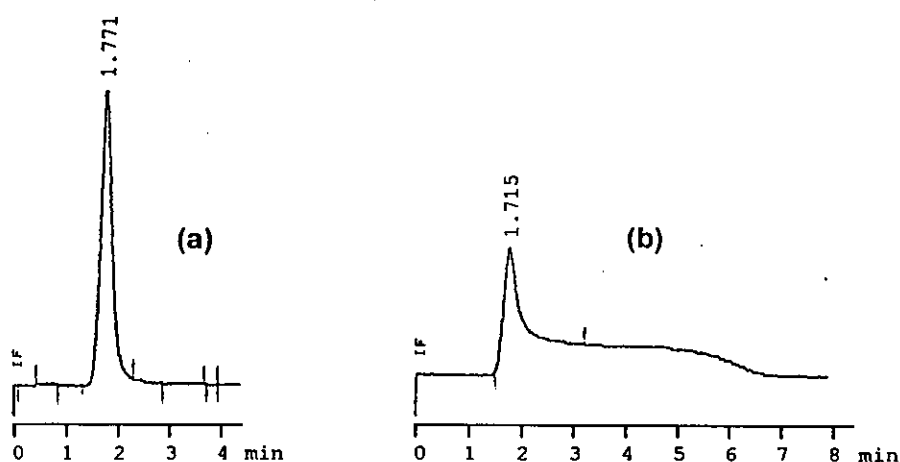
**Figure 4.8** Structure of salicylamide

Salicylamide was excellently retained by using superheated water chromatography at 180 °C, giving fluorescence at a retention time at 5.22 min (Figure 4.9). A more detailed study was subsequently carried out using one dimensional and two dimensional NMR and a MS detector (section 6.2).

**Aspirin (acetylsalicylic acid)** is classified to be in the same analgesic drug group and has a similar structure to salicylamide. When we tried to use the same conditions to separate aspirin, it was hydrolysed on the column. For example at 100 °C aspirin gave a broad tailing peak at 1.71 min, whereas salicylic acid gave a symmetrical sharp peak with similar retention at 1.77 min (Figure 4.10 a-b). If the temperature was raised to 120 °C, aspirin also gave a similar peak shape at a retention time of 1.25 min as at 100 °C but with a shorter tail and salicylic acid gave a sharp peak at 1.16 min. It was therefore thought that aspirin was probably readily hydrolysed to salicylic acid. Aspirin is known to be unstable towards hydrolysis and degrade even in the solid state [171].

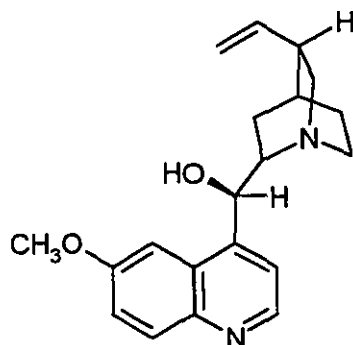


**Figure 4.9** Chromatogram of superheated water chromatography - fluorescence detection of 2  $\mu$ l 0.1060% salicylamide, corresponding to 2.12  $\mu$ g. Conditions: column, PRLP-S 5  $\mu$ m; mobile phase, deionised water; flow rate, 1.0 ml  $\text{min}^{-1}$ ; temperature, 180  $^{\circ}\text{C}$ ; back pressure, 15 kg  $\text{cm}^{-2}$ ; detection, excitation wavelength, 300 nm, emission wavelength, 430 nm.



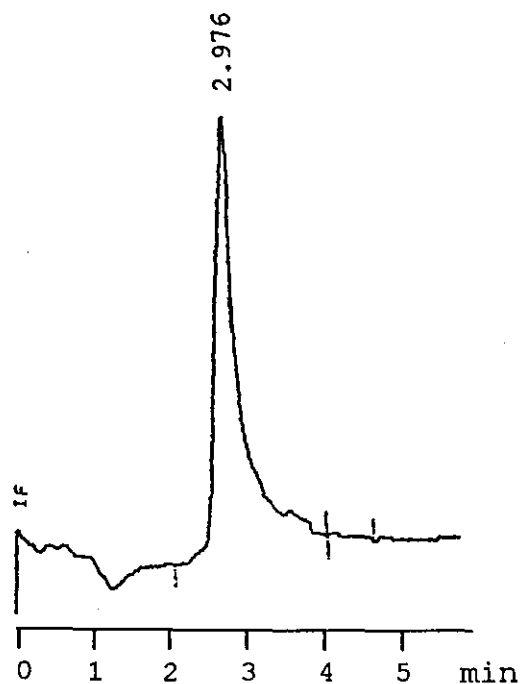
**Figure 4.10 a-b** Salicylic acid (a) and aspirin (b) separated by using superheated water chromatography with fluorescence detection. Conditions: column, PRLP-S 5  $\mu$ m; mobile phase, deionised water; flow rate, 1.0 ml  $\text{min}^{-1}$ ; temperature, 100  $^{\circ}\text{C}$ ; back pressure, 15 kg  $\text{cm}^{-2}$ ; detection, excitation wavelength, 300 nm, emission wavelength, 430 nm.

**Quinine** (Figure 4.11) is prescribed as an antimalarial drug which affects parasites, many bacteria and other unicellular organism [187]. Quinine sulphate is a white powder, soluble in water and gives UV adsorption at 347.5 nm [177]. A stability in a wide range of pH has drawn its interest to be used as a standard compound for fluorescence spectrometry [53].



**Figure 4.11** Structure of quinine

For a separation by a conventional RP-HPLC method, quinine previously needed up to 40% acetonitrile in phosphate buffer pH 2.1 containing 10 mM sodium dodecyl sulphate and 0.1 mM tetrabutylammonium bromide on an ODS column [188]. Using superheated water without additives for separation, it required a rather high temperature (240 °C) but the resulting chromatogram was satisfactory, although the peak was slightly tailing (Figure 4.12). This temperature is probably the maximum permissible temperature for the superheated water system with PRLP-S column because of softening of the stationary phase [36]. This corresponds to the use of 40% acetonitrile-water [36]. It was noticed that the chromatogram gave a more unstable baseline at very high temperature than at the moderately high temperature (<200 °C). This could be a result of an excessive heat that affected the physical properties of polymeric column and might be causing degradation, or an insufficient cooling system of eluent.



**Figure 4.12** Chromatogram of superheated water chromatography-fluorescence detection of 5  $\mu\text{l}$  0.011% quinine sulphate, corresponding to 0.55  $\mu\text{g}$ . Conditions: column, PRLP-S 5  $\mu\text{m}$ ; mobile phase, deionised water; flow rate, 0.8  $\text{ml min}^{-1}$ ; temperature, 240  $^{\circ}\text{C}$ ; back pressure, 15  $\text{kg cm}^{-2}$ ; detection, excitation wavelength, 335 nm, emission wavelength, 390 nm.

#### 4.4 Summary

In this study coupling between superheated water chromatography and fluorescence detection was achieved and lead to a comparison of the limit of detection for riboflavin with conventional HPLC. The detection limit by this method (3.6 ng) was approximately 7 times higher than the LOD (0.5 ng) found for a conventional RP-HPLC method with a Spherisorb ODS column.

In the separations of B vitamins, salicylamide and quinine on PRLP-S column with superheated water, the use of moderately high temperatures were required. Riboflavin, thiamine, pyridoxine and salicylamide needed temperature between 180-200 °C, whereas quinine needed up to 240 °C, which was close to the maximum allowable temperature of the column. This is not only because superheated water is a weak mobile phase but PRLP-S column is also highly retentive. The baseline was found to be more stable when lower temperature than 240 °C was employed. However, from the results in this chapter, it can be confirmed that superheated water could replace a mixture of organic mobile phase-water in the chromatography and gave no problem in the detection method. In superheated water conditions, there might be a decomposition and/or oxidation with sensitive analytes. In the next chapters more powerful detection methods such as NMR and MS will be coupled to the system to investigate the structure change of a number of compounds and what was happening under the superheated water condition.

---

## Chapter 5

---

# Nuclear Magnetic Resonance (NMR) Detection

When coupling on-line between liquid chromatography and NMR spectroscopy, solvent compatibility must be considered. In general, the mobile phase used for LC-NMR should be a non-proton containing solvent, for instance deuterated chloroform, methanol or acetonitrile, or carbon dioxide, because solvents with protons can mask the signals of the analyte [47]. For reversed-phase LC-NMR detection the typical mobile phase is a combination of deuterium oxide and a deuterated organic solvent. It was therefore expected that deuterium oxide would be able to be substituted for normal water mobile phase in superheated water LC-NMR. However, as the separation is performed under superheated water conditions, there is a possibility of deuteration or exchange reactions occurring. This may be determined by the NMR spectroscopy.

### 5.1 Deuterium oxide

Since the beginning of on-line coupling of conventional RP-HPLC to NMR, deuterium oxide has been employed to replace normal water as a mobile phase component. Its properties, for example the critical temperature, pressure and volume, are similar to those of water (Table 5.1). Even at elevated temperatures, deuterium oxide and water possess almost equal values of relaxation times and viscosities (Table 5.2).

**Table 5.1** Critical parameters of  $H_2O$  and  $D_2O$  [189]

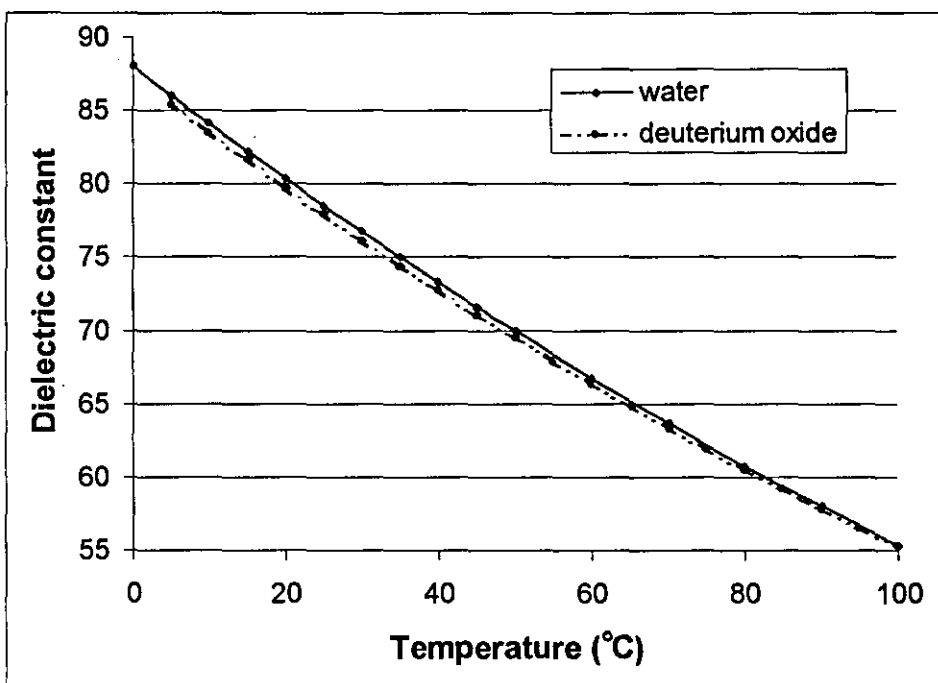
	$T_c, ^\circ C$	$P_c, \text{ bars}$	$V_c, \text{ cm}^3 \text{ mol}^{-1}$
$H_2O$ [190]	374.23	221.15	55.2
$D_2O$ [190]	371.5	217.2	54.8
$D_2O$ [191]	371.5	221.2	55.3

**Table 5.2** Comparison of relaxation times and viscosities of  $H_2O$  and  $D_2O$  [189]

$T, ^\circ C$	$\tau(D_2O)/\tau(H_2O)$	$\eta(D_2O)/\eta(H_2O)$
10	1.30	1.29
20	1.27	1.25
30	1.24	1.22
40	1.21	1.19

At elevated temperatures, it is also important to know if some important properties, such as the dielectric constants and dissociation constants, of deuterium oxide are similar to those of water. Data obtained from the CRC

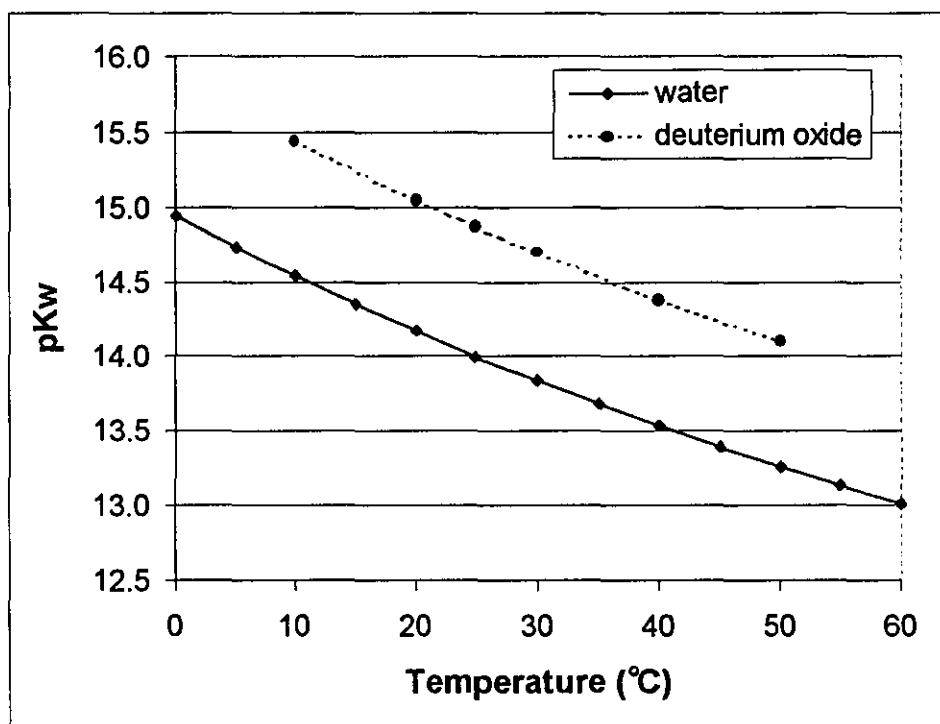
Handbook confirm the fundamental similarity in the dielectric property of water and deuterium oxide [190]. The values were plotted against temperature and are shown in Figures 5.1 and 5.2. It is clearly seen that the dielectric constants of deuterium oxide and water decrease as temperature increases and they are almost the same at each temperature, though the values at more than 100 °C were not reported.



**Figure 5.1** Comparison of dielectric constant of water and deuterium oxide between 0-100 °C (Data obtained from the reference [177]).

Figure 5.2 shows a comparison of the dissociation constants of deuterium oxide and water. It is obviously seen that between 10-50 °C the dissociation constant of deuterium oxide is approximately 1 pH lower than that of water in the same temperature range.





**Figure 5.2** Comparison of ionisation constant of water and deuterium oxide from 0 to 60 °C (Data obtained from the reference [177]).

It is postulated that most properties of deuterium oxide and water are similar. Deuterium oxide is expected to be used without any difficulties, except that it is easily converted to  $\text{H}_2\text{O}$  or  $\text{HOD}$  at ambient conditions by exchange with atmospheric water and may give a solvent interference signal at 4.7–4.8 ppm. An advantage of using deuterium oxide rather than the deuterated organic solvents for LC-NMR is that deuterium oxide is considerably cheaper (Table 5.3).

**Table 5.3** A comparison of the price of deuterium oxide and other deuterated solvents [192]

Deuterated solvent	Purity (atom %)	Price per 10 g (pounds)
Deuterium oxide	99 %	3.69
Acetonitrile- <i>d</i> 3	99 %	18.60
Methanol- <i>d</i> 3	99 %	148.40
Tetrahydrofuran- <i>d</i> 4	99 %	150.60

## 5.2 Coupling superheated water chromatography with NMR

Because of a need to position the LC away from the NMR magnet, a 3 m polyethyl ether ketone (PEEK) tubing was used to couple the UV detector to the NMR flow cell. This length also created enough back pressure to maintain a liquid state in the chromatographic column. The reported differential pressure of the 0.13 mm (or 0.005") PEEK tubing per 5-foot length is 165 psi (ca.11.4 bars) at 1 ml min<sup>-1</sup> [193], therefore over the length of the 3 m tubing, the pressure should decrease by approximately 23 bars, this pressure met the requirement of more than 15 bar in the column under superheated water conditions to maintain a liquid state. For example, at 200 °C and a flow rate of 1.0 ml min<sup>-1</sup> with 3m PEEK tubing to back-up the pressure, the column pressure is about 40 bars. The 3 m long tubing to the NMR also enabled the detection at ambient conditions because the pressure and temperature of the eluent decreased along the length of the tubing, therefore a standard low-pressure NMR probe was sufficient to handle the decreased pressure and temperature and to detect the sample. Also, the NMR results can be compared to reference spectra obtained under ambient conditions.

The transfer time between the UV flow cell and the NMR probe was first investigated. By introducing 1 mg salicylamide to the system, it was found to be 33 s with the 3 m PEEK tubing.

Samples were prepared at high concentrations because the sensitivity of NMR is moderately low [77, 194]. To increase the sensitivity, the stop-flow mode was employed by turning the switching valve to bypass the flow to the NMR spectrometer, a certain time (transfer time, i.e. 33 s) after we saw the peak appear on the UV integrator.

Initially, a back pressure regulator had been used (Figure 2.2) but we found the pressure dropped suddenly when the switching valve was turned. The same phenomenon did not happen when the regulator was replaced by a second 3 m PEEK tubing to back-up the pressure.

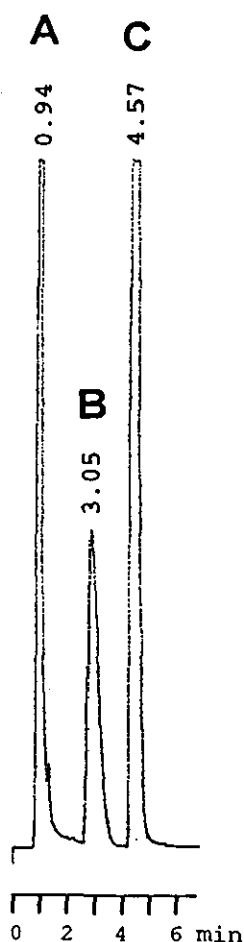
For a sample containing one major component, the NMR spectrum could be measured without any trouble using the stop-flow mode. For a mixture, not all the separated compounds could be detected in one run using the stop-flow mode, depending on the time required for signal acquisition. For example, in a chromatographic run with three major peaks at 5.0, 8.0, and 14.0 min, the NMR detection of the first peak can certainly be performed using stop-flow mode. If the NMR data acquisition time of the first peak requires less than 3.0 min, the second peak may be measured by switching back the valve, to fill the NMR flow cell with the second component. If the time requirement is between 3.0-9.0 min, measurement of the second peak is then not possible but the third peak may be trapped. Additionally, if the time required is more than 9.0 min, only first component can be achieved. Repeated injections permit the measurement of the remaining peaks.

### 5.3 Application of superheated water chromatography – NMR of analgesic and related drugs (paracetamol, caffeine, and phenacetin)

Paracetamol (or acetaminophen) and phenacetin are generally used as analgesic drugs and undergo the same function as aspirin. Both of them also have antipyretic effect but are only weakly anti-inflammatory [202]. Caffeine (or 1,3,7-trimethylxanthine) has a pharmacological action of therapeutic interest. It can relax smooth muscle, stimulate the central nervous and cardiovascular system, and enhance diuretic action. Paracetamol, caffeine and phenacetin have been extensively analysed by HPLC method [88, 195-198], particularly with octadecyl (ODS) columns [88, 197-198].

An octadecyl ( $C_{18}$ ) silica column is generally considered to be a highly efficient reproducible column. However, it is slightly less polar and considerably less thermally stable than the PS-DVB column [36]. The temperature to be used to separate the analgesics could be slightly lower than for PS-DVB column. In this experiment, to imitate the gradient elution of RP-HPLC, a temperature programme was applied for better separation. By ramping the temperature of the oven from 80 °C to 130 °C at 8 °C min<sup>-1</sup>, the mixture was well separated, giving symmetrical peaks of paracetamol (0.94 min), caffeine (3.05 min) and phenacetin (4.57 min) (Figure 5.3). The resulting chromatogram shows a successful separation on  $C_{18}$  column at the high temperature (80-130 °C). Nevertheless, subsequent runs indicated a degradation of  $C_{18}$  column, as the retentions of the analytes gradually decreased. Flushing with acetonitrile for hours afterwards did not recover the column and the retentions of all components now overlapped. On opening the column, we noticed a big void, approximately a half of column length, at the top and also a green brown colour at the column frit. However, regardless of the shorter retention, the separation patterns were reproducible, all peaks were symmetrical, sharp and the baseline was minimal. Figure 5.4

shows the NMR spectra of those analytes by operating a stop flow mode spectral collection on each peak, confirming that the compounds were separated without degradation in the column.



**Figure 5.3** Superheated water chromatogram of 100  $\mu\text{g}$  on column of each analgesic drug in a mixture: **A** = paracetamol; **B** = caffeine; **C** = phenacetin.

**Chromatographic conditions:** column, 15 cm Novapak  $\text{C}_{18}$ ; mobile phase, deuterium oxide at flow rate  $1.0 \text{ ml min}^{-1}$ ; UV absorption, 254 nm; temperature ramped at  $8 \text{ }^\circ\text{C min}^{-1}$  from  $80^\circ\text{C}$  to  $130 \text{ }^\circ\text{C}$ ; transfer time from UV to NMR detector, 33 s.

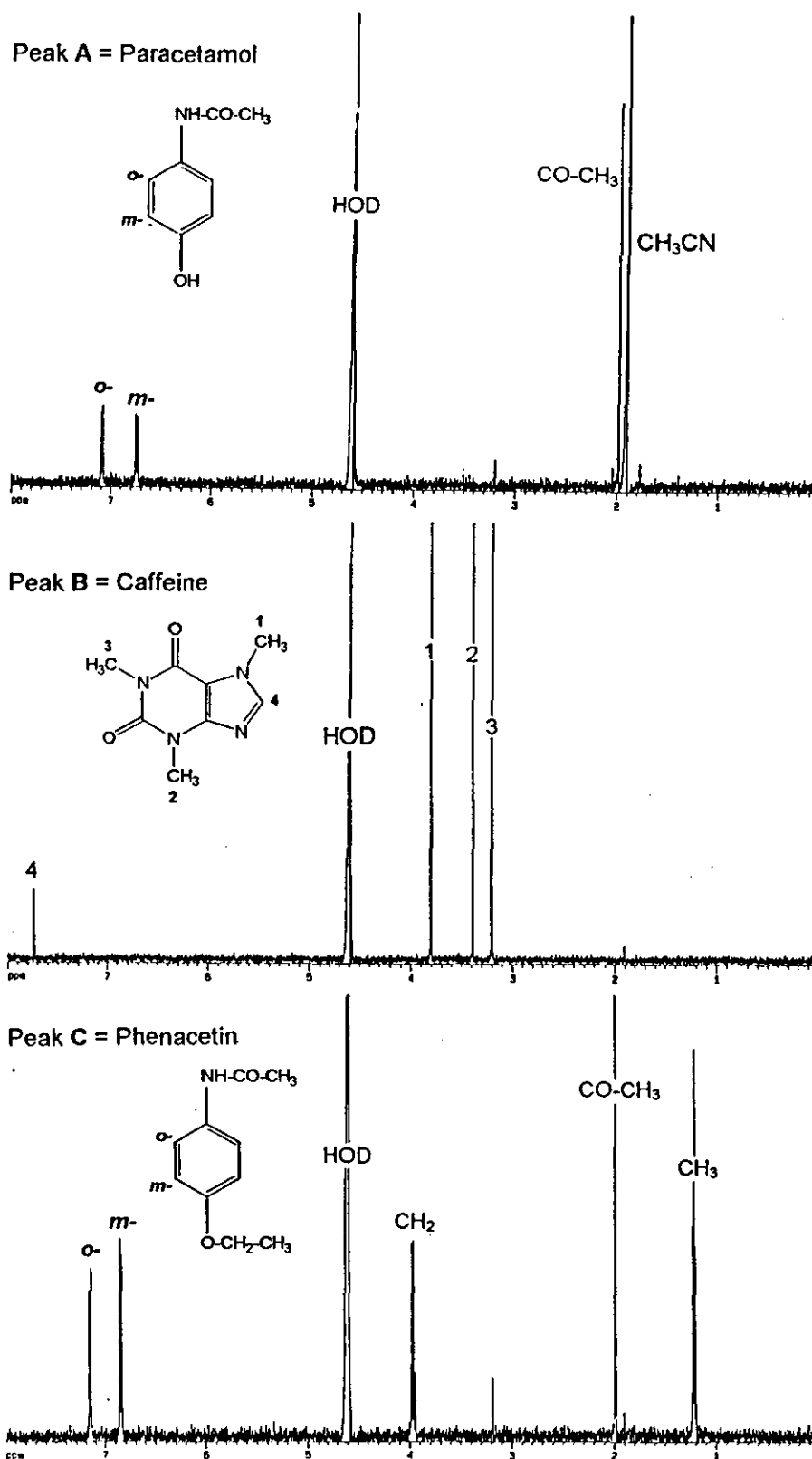


Figure 5.4 NMR spectra of each analgesics obtained using stop-flow mode for the peaks in Figure 5.3.

From the NMR spectra in Figure 5.4, the first, second and third peaks from the chromatogram in Figure 5.3 were assigned to paracetamol, caffeine and phenacetin, respectively. These could be identified by their spectral fingerprints. For example, paracetamol gave two doublets ( $J = \sim 9$  Hz) at 6.8 and 7.1 ppm, which represented H of aromatic ring, and a singlet (3H) at 2.0 ppm which corresponded to a methyl group attached to an  $-\text{NHCO}(\text{CH}_3)$  amide. Caffeine gave three singlets at 3.2, 3.4 and 3.8 ppm (Figure 5.4 b) that could be assigned to the three methyl groups on the xanthine ring, and a singlet at 7.7 ppm which was attributed to  $\text{HC}=\text{N}$  group of the xanthine. Since phenacetin is a derivative of paracetamol, NMR spectrum in Figure 5.4 c gave almost the same pattern, except for a triplet at 1.2 ppm ( $J = \sim 7-8$  Hz) and a quartet at 4.0 ppm ( $J = \sim 7$  Hz) that corresponded to the  $\text{CH}_3$  and  $\text{CH}_2$  of an ethyl group ( $-\text{OCH}_2\text{CH}_3$ ). An extra peak at 1.95 ppm in the paracetamol spectrum is attributed to  $\text{CH}_3\text{CN}$  solvent peak. All three spectra were confirmed by comparison with reference NMR spectra [199-201].

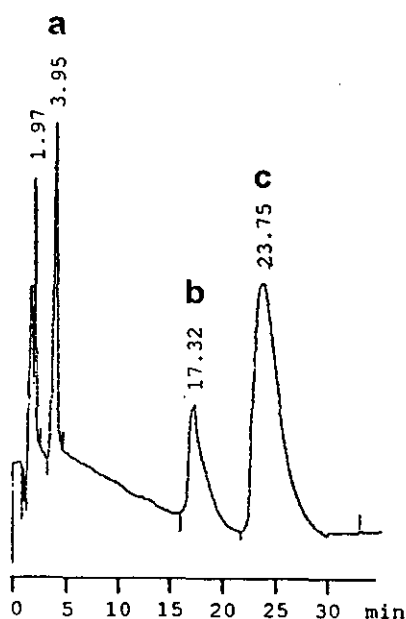
The results reflected a success in coupling superheated water chromatography and NMR spectroscopy. The study also demonstrated that deuterium oxide could substitute normal water mobile phase in superheated water chromatography without any problems. No decomposition of the drug compounds was found during the separation, as each spectrum agreed with the corresponding pure compound spectrum and no additional signals were seen, as well as the chromatogram showed pure intense peaks.

#### **5.4 Application of superheated water chromatography – NMR to barbiturates**

Since barbiturates have been introduced in 1903 as long-period sedative-hypnotic drugs [116, 202], their poisoning, such as self-poisoning, overdose, has been also reported [202]. Although the extensive use of barbiturates has now been reduced and replaced by safer drugs, some

barbiturates, such as phenobarbital and butobarbital, are still available in a combination with other drugs as a sedative for a treatment of gastrointestinal disorders, urethral inflammation, asthma, hypertension, and coronary artery disease [116].

Reversed phase LC is generally the methods to analyse barbiturates [203-205]. In earlier work at Loughborough a series of barbiturates (100  $\mu\text{g}$  of each) were separated by using superheated water chromatography with UV detection [30]. In order to confirm the structures, the same compounds separated by superheated water were detected by NMR spectroscopy. The chromatographic results and NMR spectra of three barbiturates were illustrated in Figure 5.5 and 5.6.



**Figure 5.5** Superheated water chromatogram of 100  $\mu\text{g}$  of each barbiturate in a mixture: a = barbitone; b = amylobarbitone; c = heptabarbitone.

**Chromatographic conditions:** column, 5  $\mu\text{m}$  PS-DVB column; mobile phase, deuterium oxide at flow rate 1.0  $\text{ml min}^{-1}$ ; UV absorption, 254 nm; oven temperature, 200  $^{\circ}\text{C}$ ; transfer time from UV to NMR detector, 33 s.



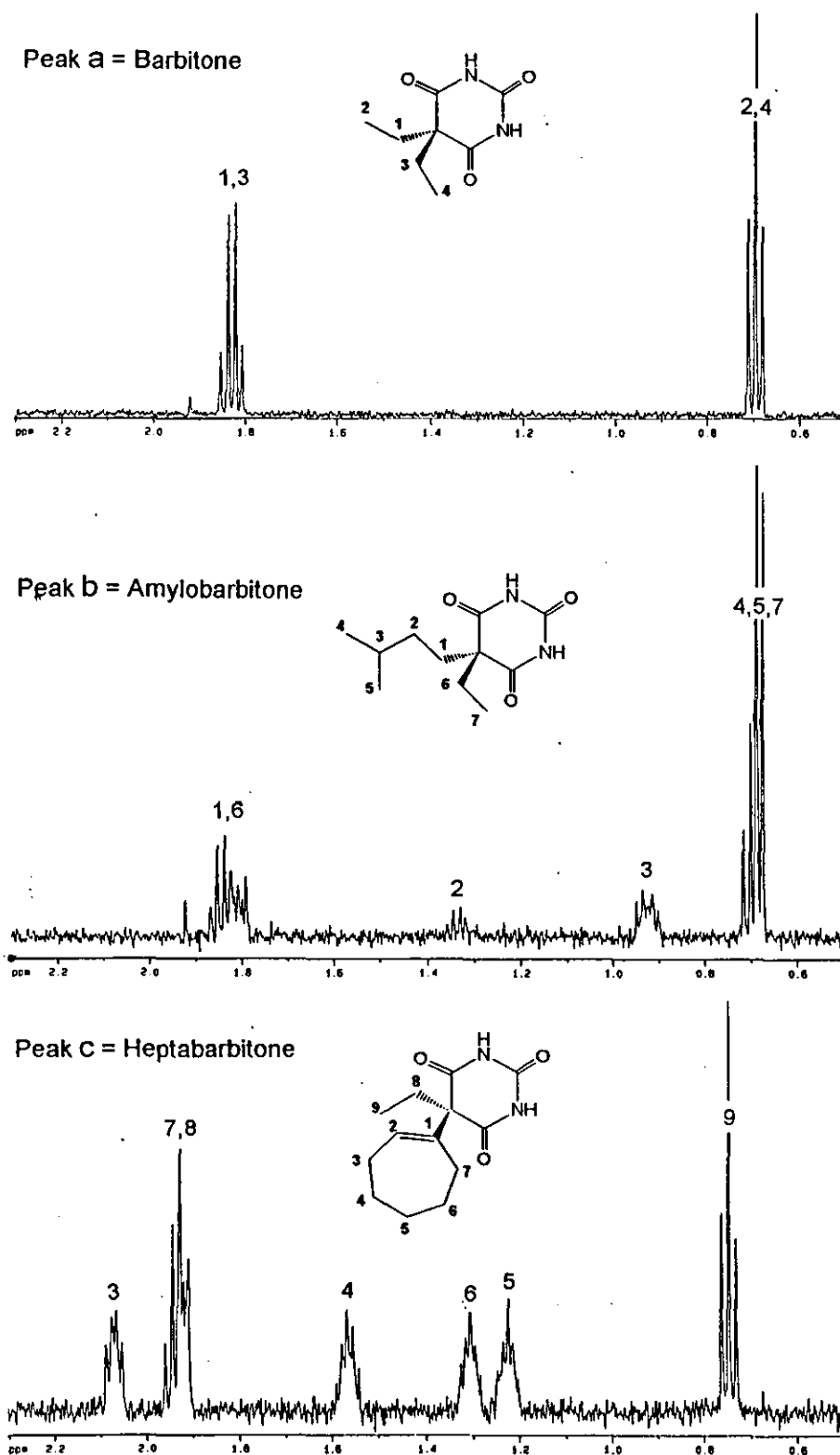


Figure 5.6 NMR spectra obtained of each barbiturate using stop-flow mode for the peaks in Figure 5.5.

The spectrum of the first peak (Figure 5.6 (a)) was easily assigned to barbitone by showing a triplet at 0.7 ppm and a quartet at 1.8 ppm, which were attributed to  $\text{CH}_2$  and  $\text{CH}_3$  of the ethyl groups of barbitone. These fingerprints matched the reference spectra [206-207]. The spectrum of amylobarbitone in Figure 5.6 (b) is slightly more complicated. The four signals near 0.7 ppm suggested the  $\text{CH}_3$  groups of both side chains of amylobarbitone; whereas a multiplet at 1.8 ppm indicated two  $\text{CH}_2$  groups attached to the ring. Meanwhile, the resonance of CH and the second  $\text{CH}_2$  of the pentyl side chain contributed to the multiplets at 0.9 and 1.3 ppm, respectively. The spectrum is similar to a 60 MHz NMR spectrum of amylobarbitone measured by Avdovich *et al.* [206], except it exhibited higher resolution fingerprints. The reference spectrum showed peaks at 0.9 ppm (doublet), 1.8 ppm (triplet) and 2.5 ppm (a small multiplet), including a moderately high background signal between 0.9-1.8 ppm.

The spectrum of the third peak (Figure 5.6(c)) was assigned to heptabarbitone. This was indicated by a triplet at 0.7 ppm ( $\text{CH}_3$  of ethyl group), a quartet at 2.1 ppm ( $\text{CH}_2$  next to olefinic bond of heptenyl ring) and three quintets at 1.2, 1.3, and 1.6 ppm ( $\text{CH}_2$  groups of the ring). A multiplet at 1.9 ppm was attributed to the overlap of  $\text{CH}_2$  peaks of ethyl group and heptenyl ring. In addition, there was a triplet at 6.0 ppm, which was attributed to the olefinic hydrogen of the side chain ring. Compared to the reference spectrum [206], some signals were matched to those of reference, for example two triplets at 0.7 and 6.0 ppm. However, because the 60 MHz NMR reference spectrum exhibited multiple broad peaks in the range of 1.0-2.5 ppm, it is not possible to match all the resonances in this work. The amide NH hydrogens attached to each N of the main barbiturate rings normally give singlets about 11.5 ppm [206], but as our working range is 0.0-10.0 ppm, it could not be seen if there was a deuterium exchange or not. Except for a weak HOD peak (~ 4.7 ppm), no additional peaks were observed.

The NMR spectra clearly show that all the barbiturates were successfully separated in the column with no degradation.

### 5.5 Application of superheated water chromatography – NMR to natural products

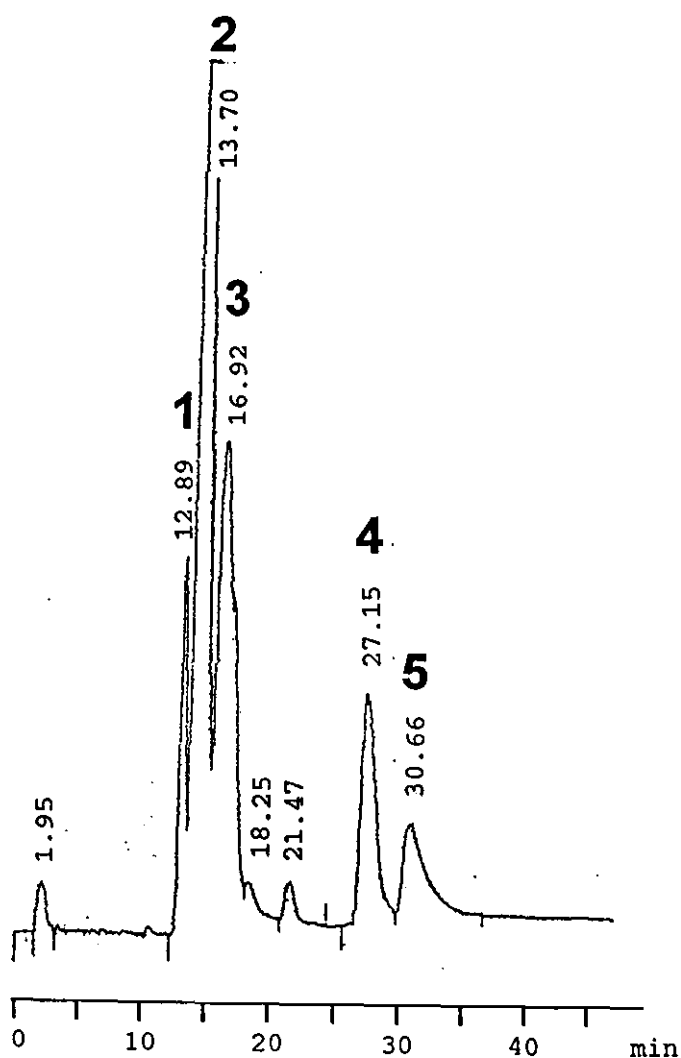
Several pharmaceutical compounds from natural products are soluble in hot water, for example, the kava lactones from *Piper methysticum* [208-209]. The root of this narcotic plant is ground, mixed with water and served as a muddy brown drink among Polynesian people [208]. Recently, this plant has attracted considerable interest. It has been processed to produce anti-depressant and sedative drugs [209]. Analysis of these products have been performed by using GC [210] and HPLC [211-212]. It is therefore of interest if the identification by using superheated water chromatography–NMR can be applied to these compounds.

In the separation of the kava extract, the polybutadiene (PBD) zirconia column was found to be the most efficient and durable column, whereas the ODS column was thermally unstable and PS-DVB column was less efficient and gave broad peaks for those extracted components. Since the PBD column had an internal diameter of 2 mm, the flow rate of mobile phase was reduced. A flow rate of 0.25 ml min<sup>-1</sup> gave a back pressure in the column on approximately 55 Kg cm<sup>-2</sup> at 80 °C. As a consequence, the transfer time between UV detector and NMR was increased to 2 min 12 s.

The temperature programme was carried out with an initial temperature of 80 °C, increasing to second level temperature at 100 °C at 8 °C min<sup>-1</sup>, then to the final temperature at 160 °C at 2 °C min<sup>-1</sup>. The temperature programme was manually operated because the programmer controller provided only one level temperature ramping program.

When 10  $\mu\text{l}$  of the root extract in methanol was analysed by superheated heavy water chromatography with UV and NMR detection, the UV spectroscopic detection showed five major peaks (Figure 5.7). The main peaks showed a retention time at 13.70 (second peak), then 16.92, 12.89, 27.15 and 30.66 min, decreasingly by size. Unfortunately the fifth peak (30.66 min) was too small to be detected by NMR. Using the stop-flow mode in NMR flow cell with a volume of 120  $\mu\text{l}$ , the first peak (12.89 min) overlapped with the second peak, the spectrum was dominated by an influx of second massive peak .

A major component that gave the large second peak in the chromatogram was identified as kawain (Figure 5.8). This was confirmed by NMR spectroscopy. Since the spectrum was complicated and has a range of interesting resonances, the entire spectrum was enlarged and divided into three ranges (Figure 5.8 a-c). The first multiplet that appeared on the spectrum at 2.7 ppm was assigned to be a geminal coupling of H5 $\alpha$  and H5 $\beta$ . The two H5 resonances also affected a vicinal coupling to H6, resulting a multiplet of H6 at 5.2 ppm. A singlet at 5.3 ppm was attributed to H3 of olefinic bond, whereas the two four resonances at 6.4 and 6.8 ppm were assigned to the coupling of H7 and H8 and a long range coupling to H6. Meanwhile, the methoxy hydrogens gave a singlet at 3.8 ppm and the aromatic ring contributed to two doublets at 7.5 ppm (*o*-) and 7.35 ppm (*p*-), and a triplet at 7.4-ppm (*m*-). A singlet at 5.9 ppm seemed to be contamination, due to an overlap between the main component and the following peak, and the singlet at 3.75 was unidentified.



**Figure 5.7** Separation of the extract of kava root in methanol by using superheated water chromatography.

**Chromatographic conditions:** column, 15 cm microbore PBD column; mobile phase, deuterium oxide at flow rate  $0.25 \text{ ml min}^{-1}$ ; UV absorption, 254 nm; oven temperature kept constant initially at  $80 \text{ }^\circ\text{C}$  then increased to  $100 \text{ }^\circ\text{C}$  ( $8 \text{ }^\circ\text{C min}^{-1}$ ) after 8 min then ramped to  $200 \text{ }^\circ\text{C}$  ( $3 \text{ }^\circ\text{C min}^{-1}$ ) after 15 min<sup>1</sup>; transfer time from UV to NMR detector, 2 min 12 s.

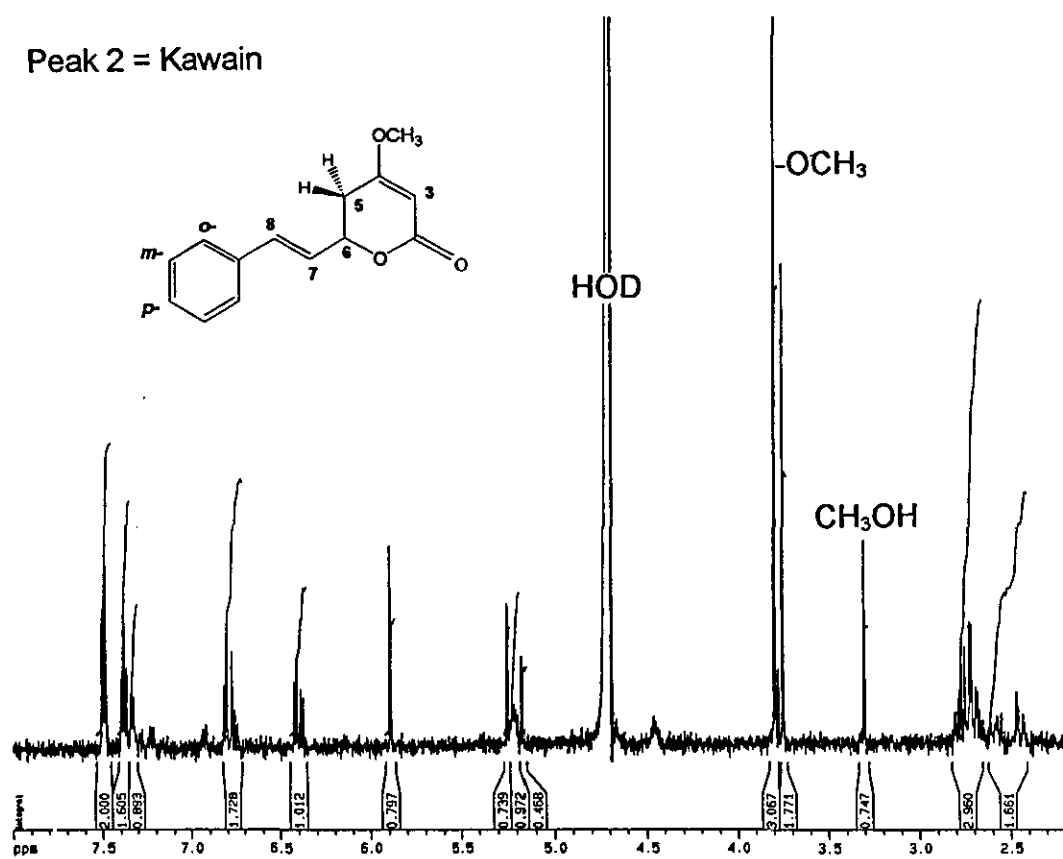


Figure 5.8 NMR spectrum obtained using stop-flow mode for the second peak in Figure 5.7.

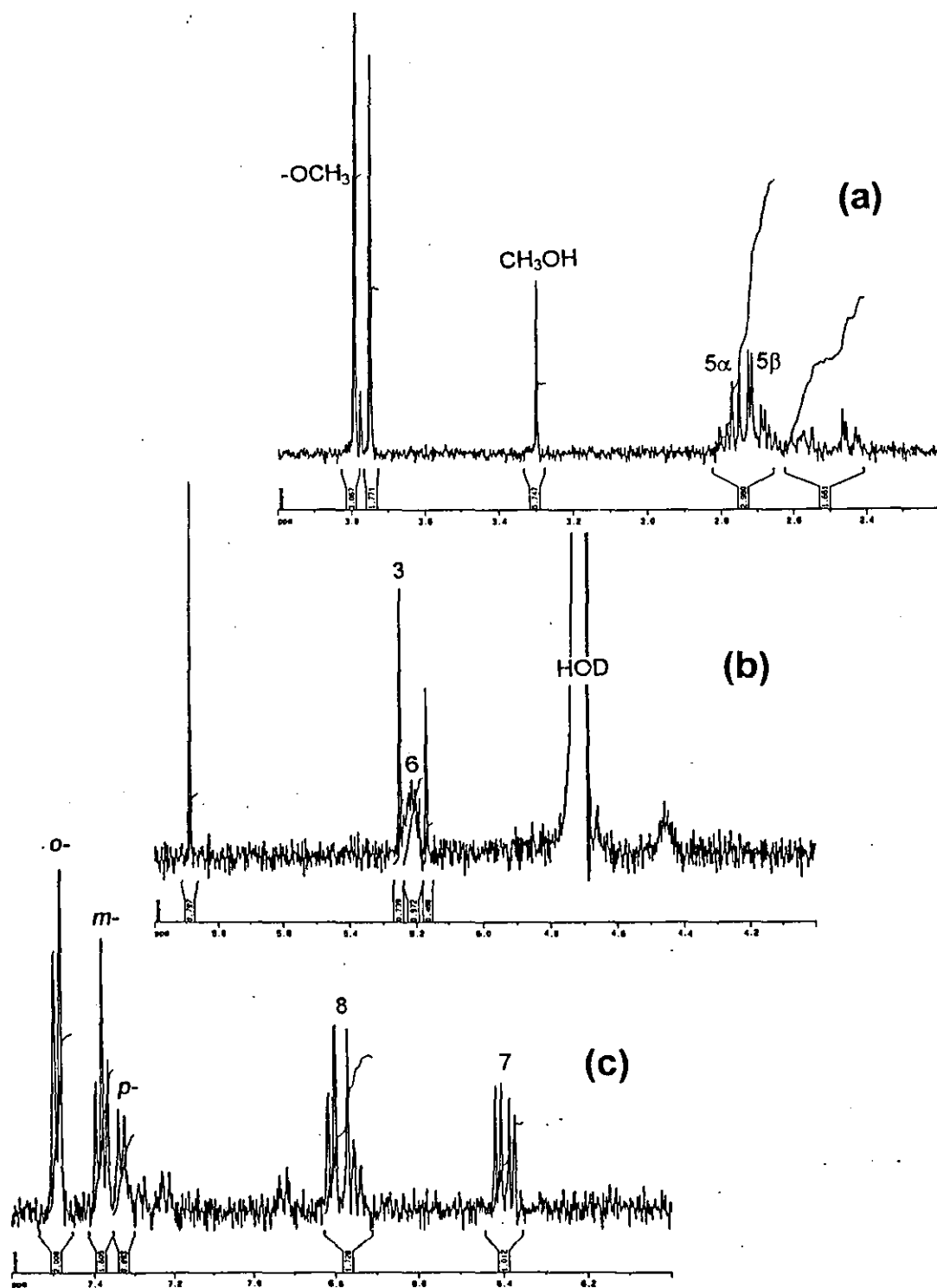


Figure 5.8 a-c NMR spectrum of Figure 5.8 enlarged in the range 2.0 - 4.0 ppm (a), 4.0 - 6.0 ppm (b), and 6.0 - 7.6 ppm (c).

The spectrum was confirmed by a comparison to a 400 MHz NMR measurement reported by Shao *et al.* [211]. Kawain resonances\* were exhibited: 2.55 ppm (dd, H5 $\alpha$ ), 2.68 ppm (dd), 3.78 ppm (s, -OCH<sub>3</sub>), 5.08 ppm (ddd, H6), 5.21 ppm (s, H3), 6.27 ppm (dd, H7), 6.74 ppm (H8), and 7.29-7.41 ppm (m, H<sub>aromatic</sub>). The resonances of kawain in this work show a similarity to those reported, except the multiplet of H5, which exhibited two double doublets at 2.55, and 2.68 ppm in the report. In addition, the resonances of H<sub>aromatic</sub> in the present work could be distinguished as two doublets of *o*- and *p*-, and one triplet of *m*-phenyl ring. This is owing to a higher efficiency of NMR magnet used (500 MHz) in this work.

The second largest peak (Peak 3) in the chromatogram was proved to be methysticin (Figure 5.9). The resonance in a range of 2.0-5.8 ppm which represented the main ring and olefinic bond of methysticin exhibited exactly the same pattern as kawain and the chemical shifts were assigned to H3, H5, H6 and methoxy group (Figure 5.9 a-b). A singlet at 5.95 ppm indicated the two H12 of dioxy 5-membered ring side chain. In Figure 5.9 c, the resonance of H7 appeared as a double doublet at 6.2 ppm. The dioxy 5-membered ring has a significant shielding effect on the phenyl group. As a result, the resonances of aromatic hydrogens shifted to higher field. This was indicated by two doublets at 6.85 ppm (H9) and 6.95 ppm (H10), and a singlet at 7.1 ppm (H11). In addition, a doublet at 6.7 ppm (H8) of conjugated olefinic bond was also slightly shifted to lower shielded frequency.

---

\* Abbreviations of the resonance: s = singlet, d = doublet, dd = double doublet, ddd = double double doublet, and m= multiplet.



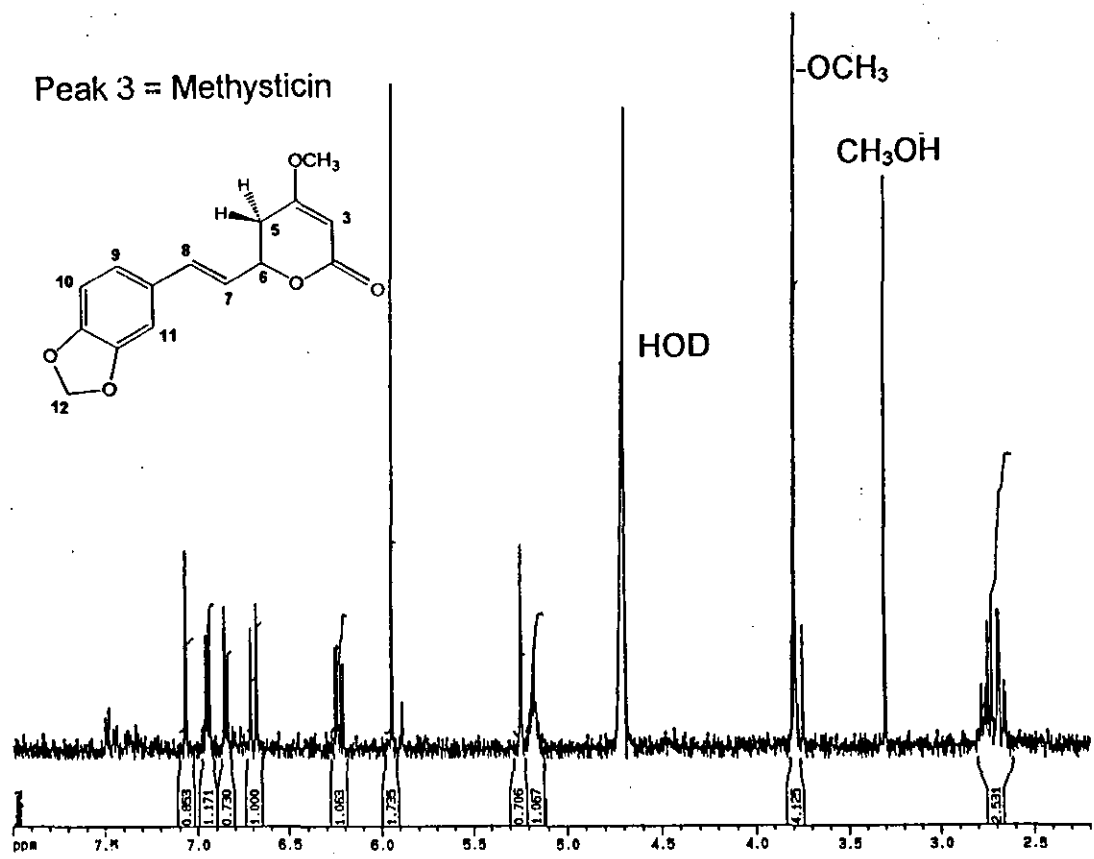


Figure 5.9 NMR spectrum obtained using stop-flow mode for the third peak in Figure 5.7.

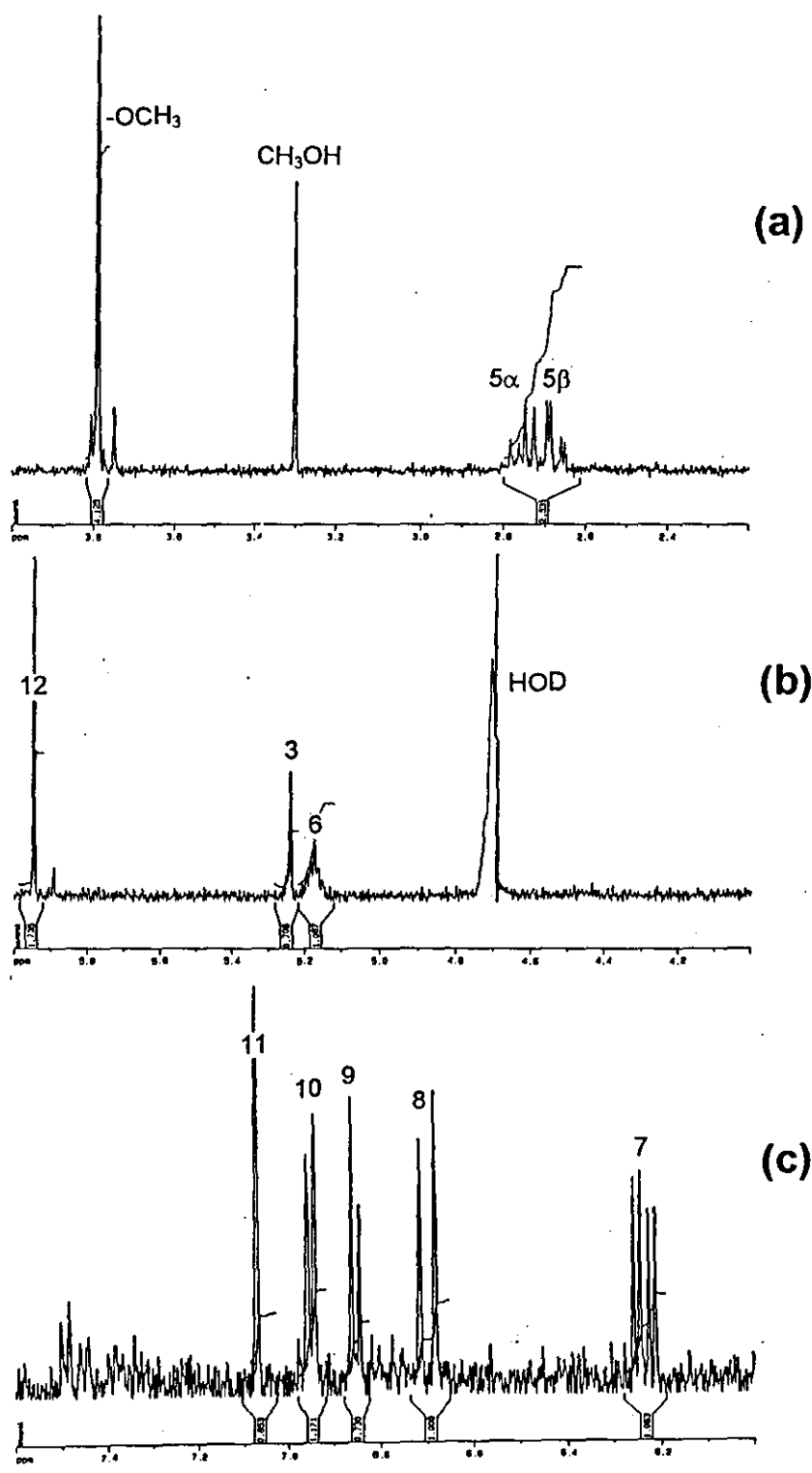


Figure 5.9 a-c NMR spectrum of Figure 5.9 enlarged in ranges of 2.2 - 4.0 ppm (a), 4.0 - 6.0 ppm (b), and 6.0 - 8.0 ppm (c).

Shao *et al.* [211] reported the resonances of methysticin\*: 2.53 ppm (dd, H5 $\alpha$ ), 2.66 ppm (dd, H5 $\beta$ ), 3.77 ppm (s, -OCH<sub>3</sub>), 5.03 ppm (ddd, H6), 5.20 ppm (s, H3), 5.97 ppm (s, H12), 6.09 ppm (dd), 6.64 ppm (d, H8), 6.77 ppm (d, H9), 6.84 ppm (d, H10), and 6.93 ppm (d, H11). A comparison between the resonances of the present work to those reported showed a similarity except for the signals of H5 at 2.7 ppm that exhibited a multiplet instead of two double doublets as reported.

Demethoxyyangonin is present in the root extract at high concentrations (ca. 21%) [212]. The NMR spectrum suggested that the third peak was likely to be demethoxyyangonin as shown in Figure 5.10. Compare to the NMR spectrum of kawain (Figure 5.8 c), the aromatic resonances gave almost the same pattern and chemical shift in the range of 7.3-7.6 ppm. The hydrogens at H5 and H6 were substituted by double bond; therefore the multiplet at 2.75 ppm disappeared and assigned a singlet at 6.7 ppm (H5) instead. A deshielding effect of the olefinic bond (C5-C6) and aromatic ring contributed to the shift of H7 and H8 resonances to lower field (6.85 and 7.5 ppm, respectively), so did the effect of olefinic bond to H3 singlet (5.7 ppm). The singlet at 2.9 ppm was attributed to a methoxy group of the main ring, like kawain spectrum.

Again, compared to the NMR spectrum of demethoxyyangonin measured by Shao *et al.* [211], the resonances\* was reported at 3.83 ppm (s, -OCH<sub>3</sub>), 5.01 ppm (d, H3), 5.96 ppm (d, H5), 6.59 ppm (d, H7), and 7.34-7.54 ppm (m, H8 and H<sub>aromatic</sub>). The spectrum in this work is slightly different from that reported. The H3 and H5 exhibited two singlets instead of two doublets and a doublet assigned to *o*- aromatic hydrogen could be distinguished from the multiple resonance of H8, *m*- and *p*- aromatic hydrogen.

---

\* Abbreviations are as previously described.

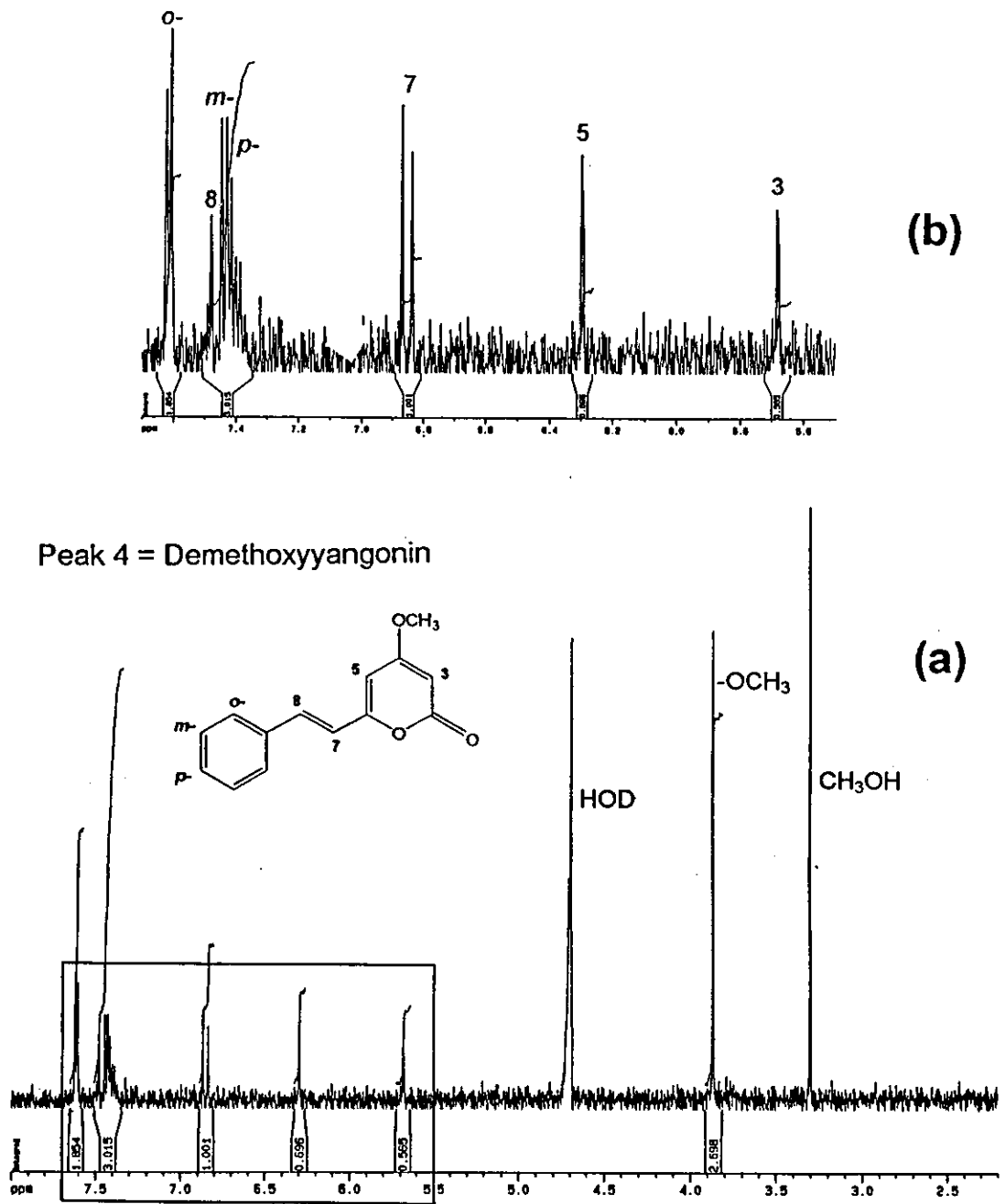


Figure 5.10 NMR spectrum obtained using stop-flow mode for the fourth peak in Figure 5.7.

(a) = A whole range spectrum between 2.3 - 8.0 ppm.

(b) = An enlarged spectrum of (a) in a range of 5.5 - 7.7 ppm.

The spectra of the major component peaks of kava extract confirmed by comparison with reference spectra demonstrated that the separation and simultaneous identification using superheated water chromatography-NMR method for natural products were feasible. Applications of the method for environmental, food, industrial and other real samples may also be possible.

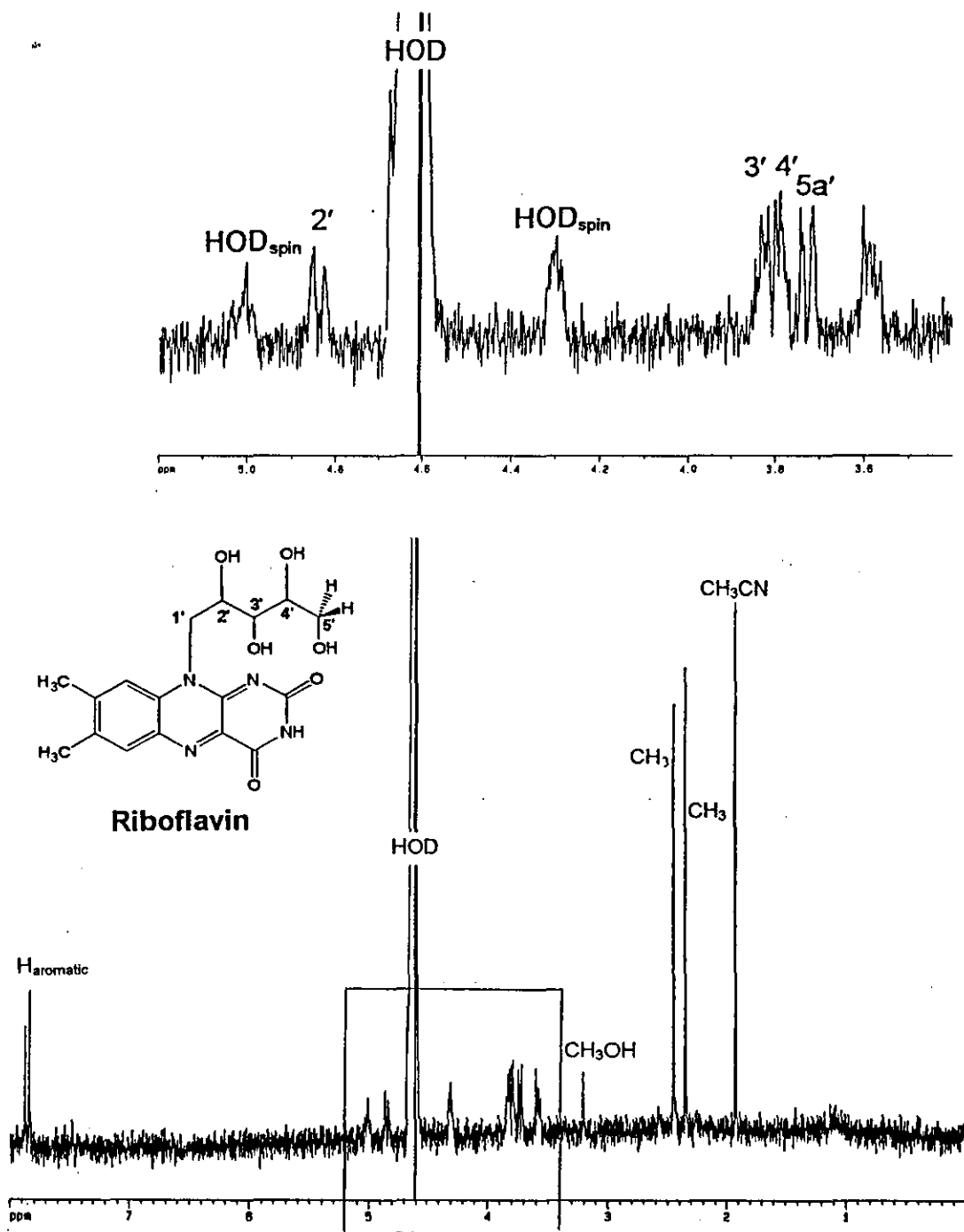
### **5.6 Application of superheated water chromatography – NMR to riboflavin**

Riboflavin analysed by superheated water chromatography with NMR detection method is more of interest, since riboflavin may change under the superheated water conditions. Riboflavin has a very low solubility in water (1 g / 3000-15,000 ml water) [171] and negligible solubility in any organic solvents, resulting in difficulties in preparing a riboflavin solution for identification by NMR.

As the solubility of riboflavin in water is very low, the saturated solution of riboflavin in deuterium oxide was prepared and introduced to the system under the same conditions (e.g. 200 °C) as previously mentioned in Figure 4.2. The data acquisition time needed to be longer to obtain NMR spectrum (Figure 5.11). As with many other NMR spectra of compounds detected at very low concentration, water (HOD) peak was always present at 4.6–4.7 ppm with two spinning side bands at 4.3 and 5.0 ppm. The singlets at 2.35 and 2.45 ppm were assigned to two methyl groups on the aromatic ring, and aromatic hydrogens resonated as two singlets at ca. 7.9 ppm. A more complicated signal in a region of 3.4 to 5.2 ppm, (Figure 5.11), represents the proton on the ribityl side chain of riboflavin. The four resonances at 3.6 ppm were attributed to 5b' and the split doublet peak at 3.7 ppm was assigned to 5a'. This was the result of the magnetic inequivalence of the two geminal hydrogens at position 5'. The multiplet at 3.75-3.9 ppm was ascribed to an

overlapping of the two resonances of H3' and H4' of the side chain. However, the spectra assigned to the structure of ribityl side chain and its analogs has been studied [213]. An extra peak appeared at 1.95 ppm was attributed to CH<sub>3</sub>CN peak which was a carryover of solvent residue from the instrument. All resonances corresponded to those from reported NMR spectrum of the ribityl side chain of riboflavin measured under ambient conditions [213].

Unexpectedly, the spectrum shows a doublet at 4.85 ppm of H2' resonance instead of a quartet and no resonance for two H1' which were expected to be at 5.0-5.1 ppm from earlier work [213]. Hence, it was thought that there might be a deuterium exchange of two H1' hydrogens. As there was no information by mass spectrum or other methods, the reaction could not be confirmed. However, no degradation product of riboflavin was found in our investigation.



**Figure 5.11** NMR spectrum of riboflavin separated by superheated heavy water chromatography. Enlarged NMR spectrum is in the range of 3.4 - 5.2 ppm.

## 5.7 Summary

The coupling of superheated water chromatography to NMR spectroscopy was highly successful, although there was a little trouble with the difference in UV and NMR sensitivity. Compare to UV detection, the sensitivity of NMR is very low. The detection was carried out by using the stop-flow mode with an exact transfer time and a preparation of high concentration sample. Due to the use of a 3 m PEEK tubing for system connection and for supporting the pressure, the detection was carried out at ambient conditions. With the on-line method, compounds can be separated and simultaneously identified by NMR. As a result, the perfect spectra of separated components, such as analgesics and barbiturates, were achieved and compared to literature. The comparison showed a similarity in resonance frequencies and patterns of sample and reference spectra for each compound. An application of the method to separate and identify kava lactone natural products was also achieved, demonstrating the feasibility of the method for other applications, for example environmental, food, industrial, etc. No degradation products were found but a deuteration of riboflavin was possible. To confirm the deuterium exchange reaction additional information, such as mass spectrum, may be needed. In the next chapter, a hyphenated method of on-line coupling between superheated water-NMR and mass spectrometry (MS) will be demonstrated and some reactions that might take place will be explained.



---

---

## Chapter 6

---

---

# Hyphenated Methods of Detection

In the previous chapter, we demonstrated the coupling of superheated water chromatography to NMR spectroscopy. The chromatographic and NMR results showed that the hyphenated system worked well. A further coupling of the system to mass spectrometer (MS) can be more interesting, since MS provides additional information to confirm the identification, particularly if a reaction occurs under superheated water conditions.

### 6.1 Coupling superheated water to NMR and mass spectrometer (MS)

The configuration of the instruments was changed to couple the MS instrument to the superheated water chromatography-NMR system (Figure 2.3). Because MS is very sensitive technique and requires only a very small amount of sample, a T-piece for splitting the eluent was inserted before the NMR spectrometer, one way leading to the NMR spectrometer (20 cm) and the other way to the MS (200 cm). In addition, there was a capillary leading

to the ionisation chamber of MS, giving a split ratio of the eluent of 20:1 between the NMR and the MS. Because the time for the sample to reach the NMR spectrometer was shorter, when the flow was stopped to measure the NMR spectrum (in stop-flow mode) the sample being transferred to the mass spectrometer was still residing in the connecting tubing. When the flow was resumed, the sample was then transferred to the MS and detected.

Although many mass spectrometers have a problem if there are any solid salts in the eluent, the instrument used in the present study has a Z configuration (Figure 1.9 b) so that the buffer salts accumulated on a guard plate [112].

## 6.2 Application to salicylamide

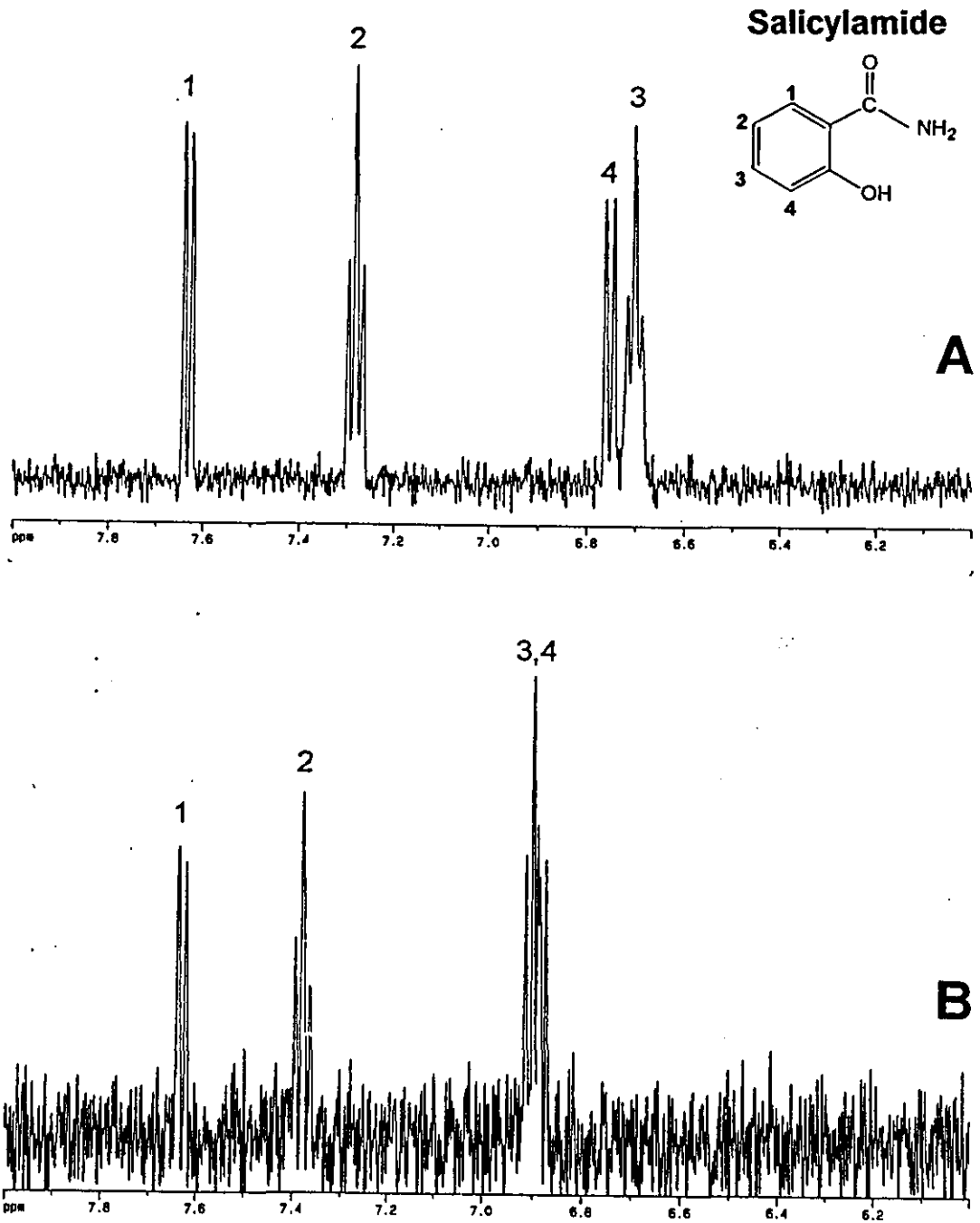
Salicylamide was successfully separated using superheated water chromatography with fluorescence detection as shown earlier (Section 4.2). Using these conditions it was decided to use salicylamide to demonstrate that a separation by superheated deuterium oxide could yield 1D and 2D-NMR spectra and MS detection.

For the first trial with salicylamide, a deuterium oxide mobile phase was employed, resulting a well-shaped peak at a retention time of 4.7 min with UV detection at 254 nm. The peak was very similar to the one detected by the fluorescence detector in Figure 4.5. The eluent was then transferred for NMR and MS detection. To increase the sensitivity by NMR, the stop flow mode was employed with the transfer time from UV detector to NMR of 33 s. A spectrum of salicylamide with very low background noise was then obtained (Figure 6.1 A).

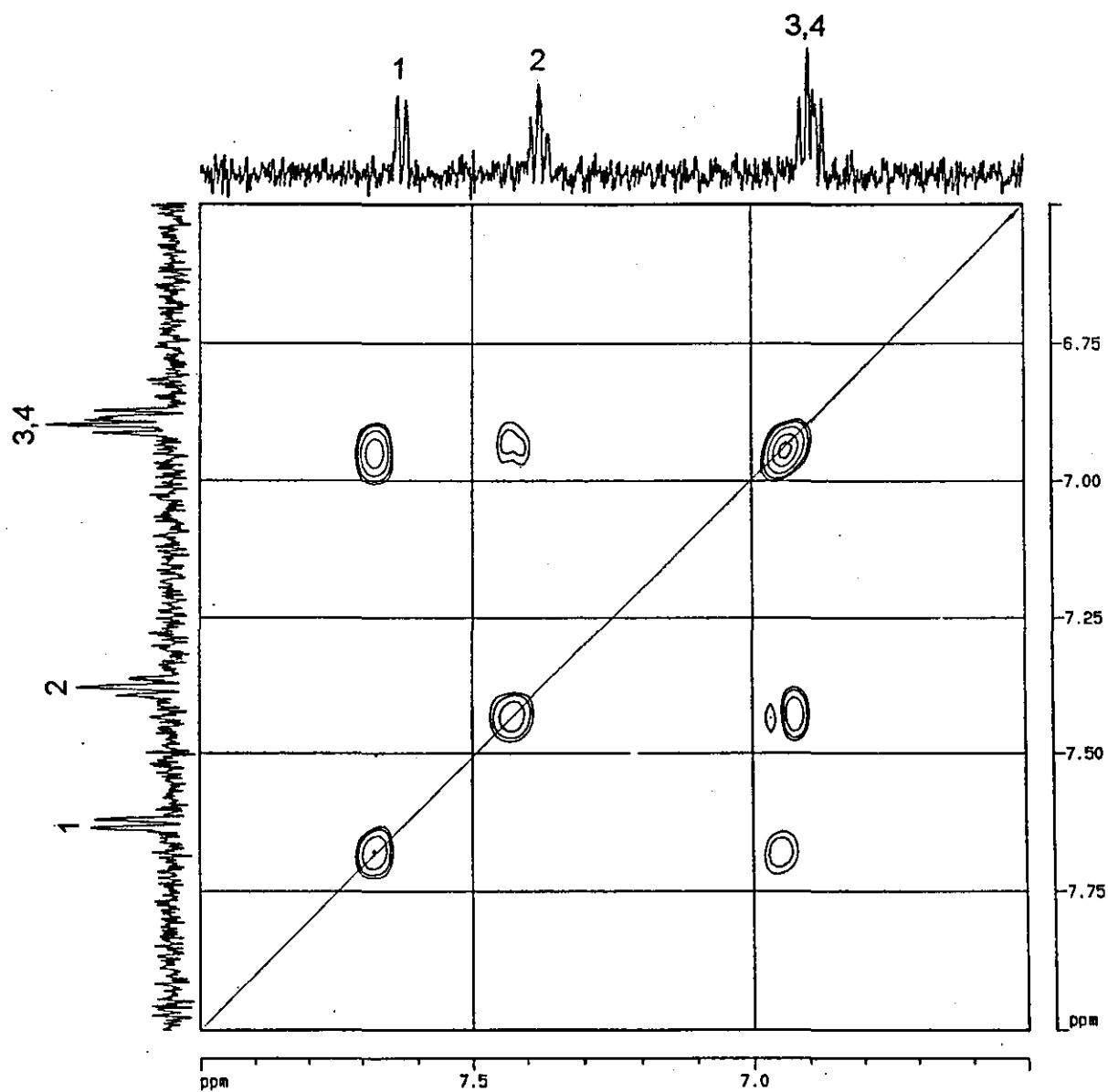
In a second trial, the mobile phase was changed to deuterated phosphate buffer pH 3.0, the temperature was raised to 190 °C isothermally and the other conditions remained the same. Under these conditions, salicylamide gave a well-shaped peak at 3.87 min. However, the NMR spectrum was slightly different from the one separated by pure superheated deuterium oxide (Figure 6.1 B).

NMR spectrum of salicylamide separated in pure deuterium oxide in the first trial showed very low background noise and high resonance intensity (Figure 6.1 A). All resonances could be assigned: two triplets at 6.7 ppm (H3) and 7.1 ppm (H2), two doublets at 6.75 ppm (H4) and 7.6 ppm (H1). However, the chemical shifts of many compounds can be affected by the solvent or the mobile phase used [66, 214]. As the dissociation constant of salicylamide is  $4.3 \times 10^{-9}$ , in unbuffered water, salicylamide is present in its undissociated molecular form [214]. Changing the mobile phase to deuterated phosphate buffer pH 3.0 caused a change in the ionic strength of the mobile phase. In this spectrum the H3 triplet and H4 doublet overlapped at 6.9 ppm (Figure 6.2 B) and H2 resonated at higher field (7.4 ppm). The signals showed a good agreement with the reference spectrum [199].

The collection of two-dimensional NMR spectra have been reported by the on-line coupling of SFC-NMR and HPLC-NMR [48, 69]. It was of interest to determine if such spectrum could be obtained by using superheated water chromatography coupled to NMR. Salicylamide is not symmetrical compound, as the structure shown in Figure 6.1, it was therefore used as an example for the demonstration.



**Figure 6.1** NMR spectra obtained using stop-flow mode for 100  $\mu\text{g}$  salicylamide separated on elution by  
A = deuterium oxide  
B = deuterated phosphate buffer



**Figure 6.2** Two dimensional NMR spectra obtained using stop-flow mode for 100  $\mu\text{g}$  salicylamide separated on the column with deuterated phosphate buffer pH 3.0 mobile phase.

From the contour spectrum (Figure 6.2), the spectra at the upper and the left edges of the plot are the normal one-dimensional spectra. Three resonances on the diagonal line correspond to the three signals on the normal spectrum. From off-diagonal peaks, it is clear that the H3 and H4 coupled with both H1 and H2, whereas the H1 and H2 did not coupled to each other. It is assumed that, by choosing appropriate experimental conditions, on-line separation and COSY spectrum of more complicated compounds could be achieved using the same technique, and a long range coupling of small resonances could be seen.

When the eluent flow was resumed, the MS experiment was performed, yielding the signals from mass spectrometric detector shown in Figure 6.3. The resulting spectrum showed strong signals at  $m/z$  ratio of 142, 163, and 179. The molecular mass of salicylamide is 137 but once salicylamide was dissolved and separated in acidic deuterium oxide, deuterium exchange occurred at the amino ( $-\text{NH}_2$ ) and hydroxy groups ( $-\text{OH}$ ) and a  $\text{D}^+$  adduct was formed. As a result, the molecular ion was increased to 142 which indicated a deuterated salicylamide ion ( $[\text{MD}]^+$ ). Since the buffer contained also sodium and potassium phosphate to adjust the pH, with the use of electrospray MS, the  $\text{Na}^+$  and  $\text{K}^+$  adducts of salicylamide were also formed (by replacing  $\text{D}^+$ ) and formed the MS peaks at  $m/z$  163 ( $[\text{MNa}]^+$ ) and 179 ( $[\text{MK}]^+$ ), respectively (Figure 6.3).

Thus a demonstration using salicylamide as an example has shown a successful on-line coupling of a superheated water chromatography-NMR-MS hyphenated system. With the stop-flow NMR, the salicylamide spectrum could be obtained and the resonances agreed with those of the reference. A demonstration to obtain COSY spectrum of salicylamide was also performed. The MS result showed a successful use of phosphate buffer mobile phase with the electrospray, resulting the  $m/z$  of  $\text{D}^+$ ,  $\text{Na}^+$  and  $\text{K}^+$  adduct of

salicylamide. It should be noted that although buffers was used, there was no contamination of the ion source because of the "Z" spray design)

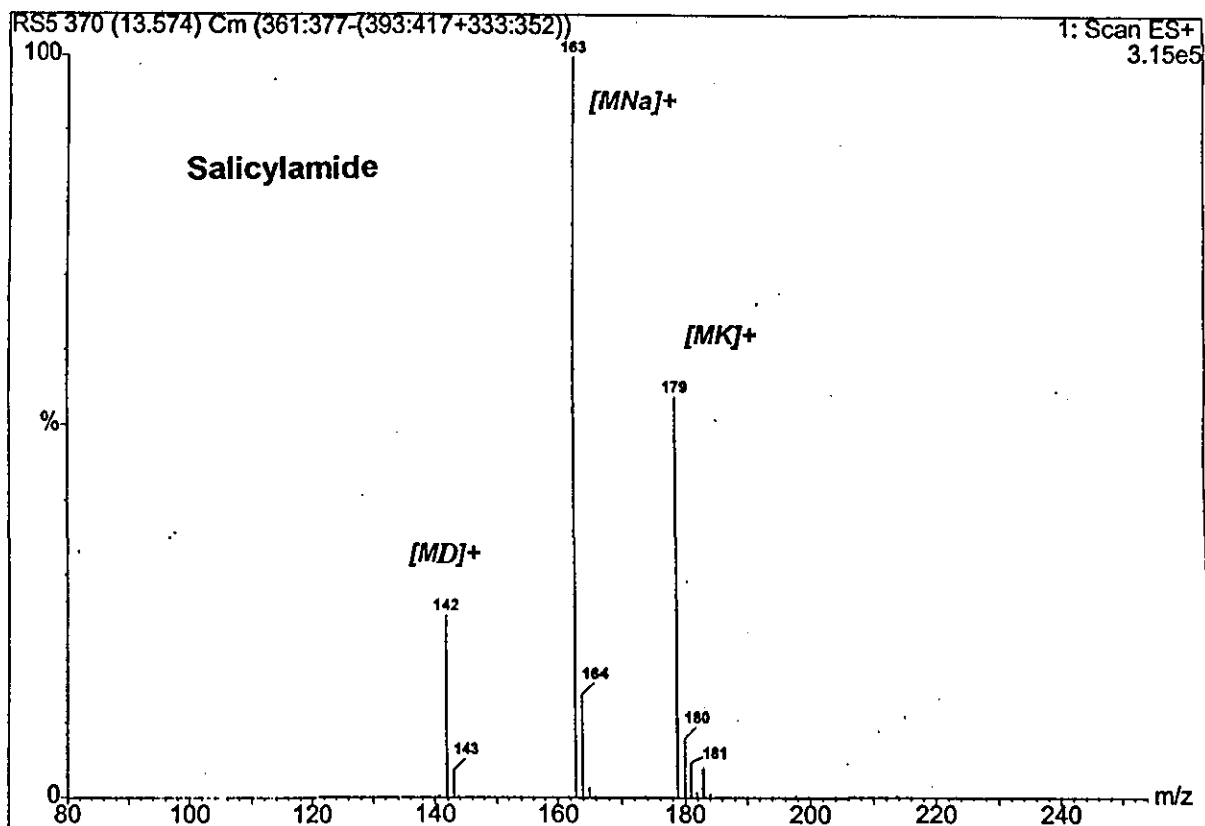


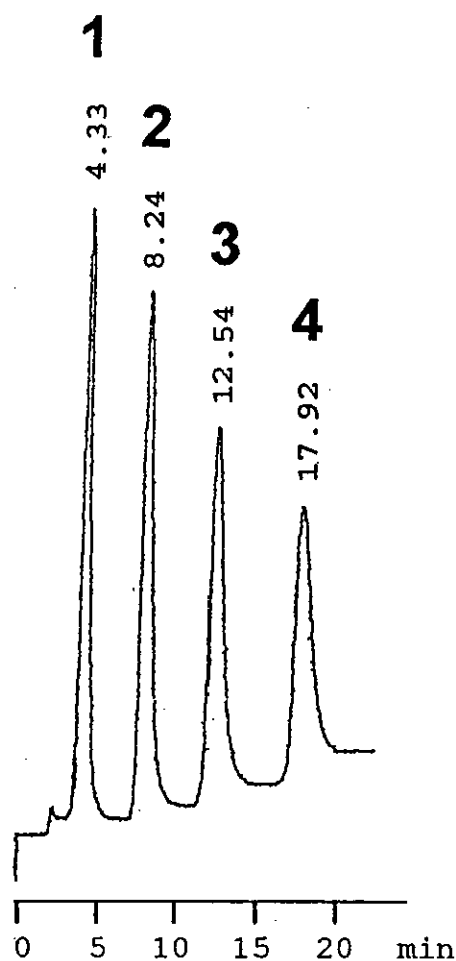
Figure 6.3 MS spectra of salicylamide separated using deuterated phosphate buffer pH 3.0.

### 6.3 Application to sulfonamide compounds

The sulfonamide compounds were previously investigated in Chapter 3. They were successfully separated on PS-DVB column using both pure and buffered superheated water as a mobile phase with ultraviolet detection. In addition, the  $pK_a$  of some sulfonamides were determined under the superheated conditions.

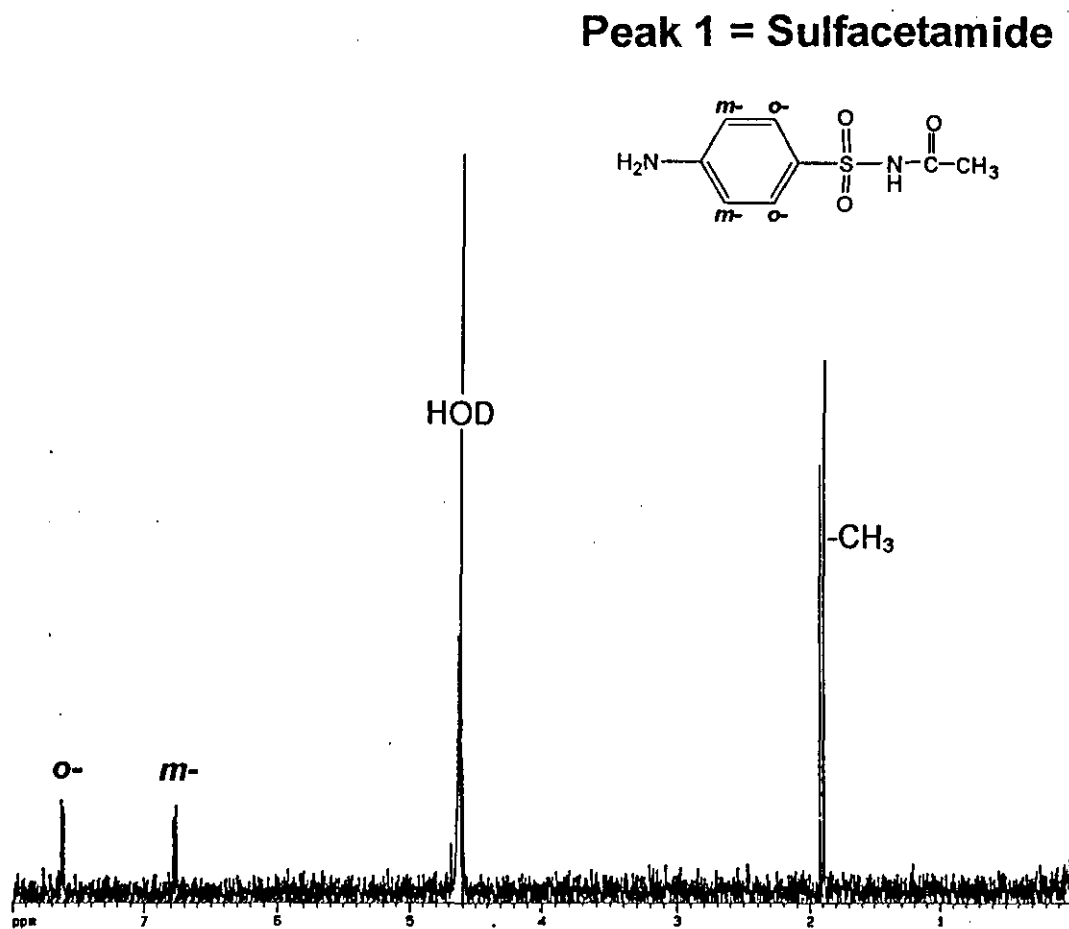
In this section, some homologous and isomeric sulfonamides were studied in the coupled system. Sulfacetamide, sulfadiazine, sulfamerazine, and sulfamethazine were separated by using buffered deuterium oxide pH 3.0 and with a temperature programme (Figure 6.4). A good separation was obtained as well as using normal buffer in the previous experiment and 4 well-resolved peaks could be assigned to sulfacetamide, sulfadiazine, sulfamerazine and sulfamethazine at retention times of 4.33, 8.24, 12.54, and 17.92 min, respectively (Figure 6.4). With a stop flow mode, NMR spectral data of the first and third peak were collected on the first chromatographic run and on the second run the spectral data collection of the third and fourth peak were performed (Figure 6.5-6.8). In each case the MS spectra were determined (Figure 6.9).



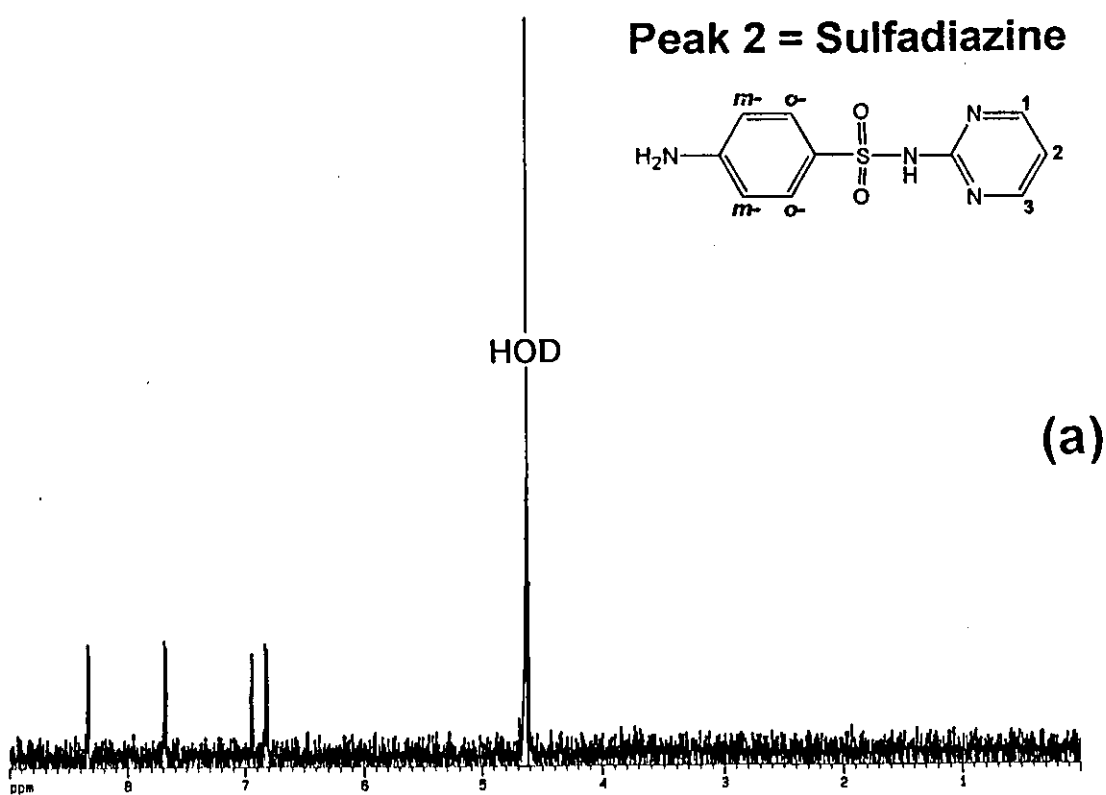
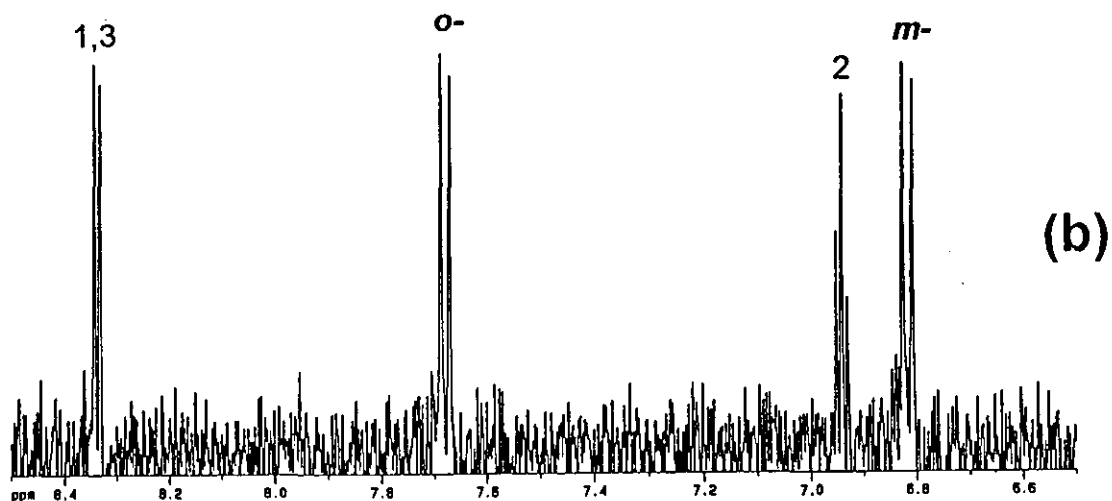


**Figure 6.4** Chromatogram of a mixture of each 100  $\mu\text{g}$  sulfonamide on column separated by using superheated deuterium oxide pH 3.0: 1 = sulfacetamide; 2 = sulfadiazine; 3 = sulfamerazine; 4 = sulfamethazine.

**Chromatographic conditions:** column, 5  $\mu\text{m}$  PS-DVB column; mobile phase, deuterated phosphate buffer pH 3.0 at flow rate 1.0  $\text{ml min}^{-1}$ ; oven temperature programmed at 160  $^{\circ}\text{C}$  then increased to 200  $^{\circ}\text{C}$  at 2  $^{\circ}\text{C min}^{-1}$ ; UV absorption, 254 nm; transfer time between UV and NMR, 33 s.



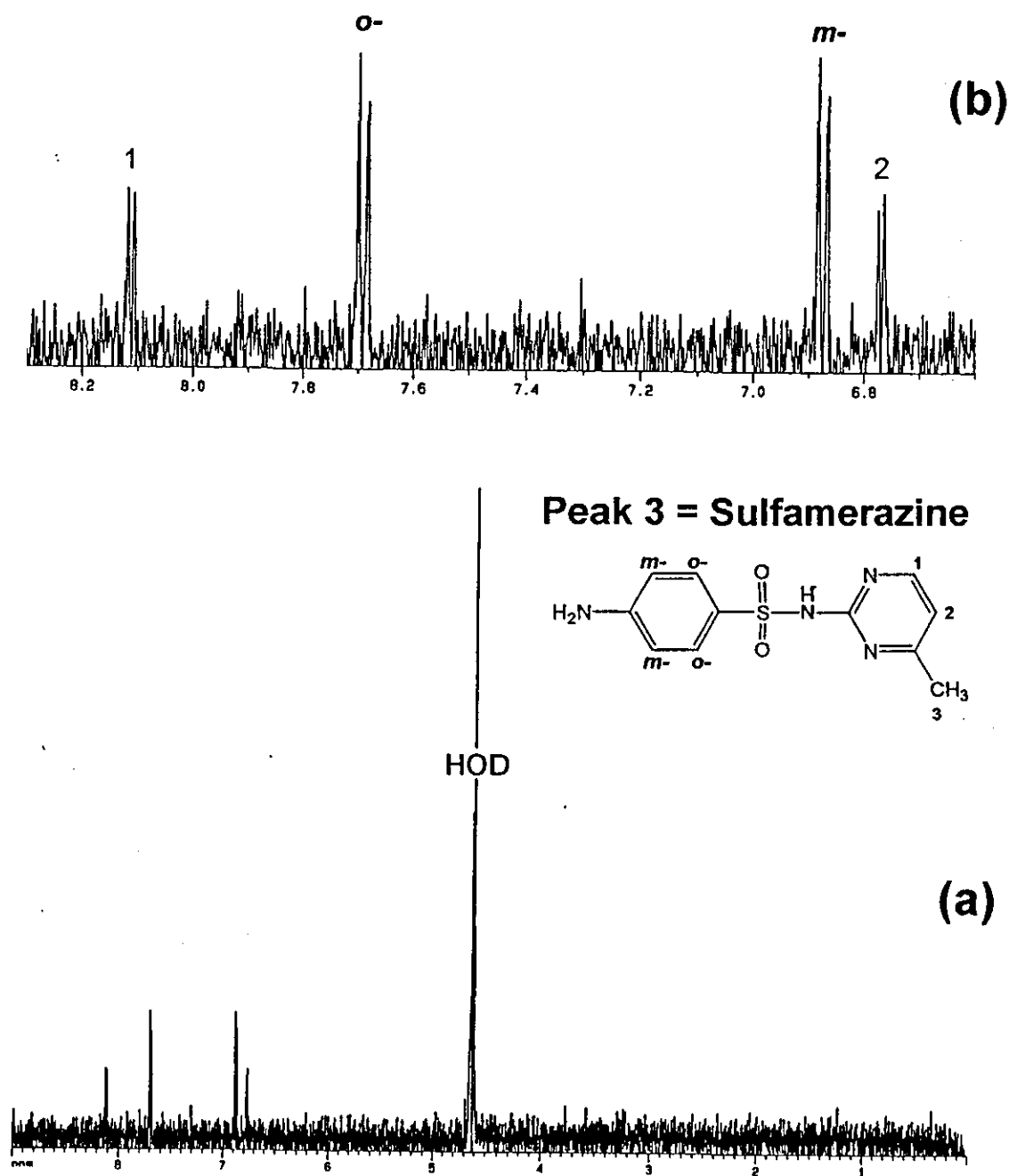
**Figure 6.5** NMR spectrum obtained using stop-flow mode for the first peak in Figure 6.4, corresponding to sulfacetamide.



**Figure 6.6** *NMR spectrum obtained using stop-flow mode for the second peak in Figure 6.4, corresponding to sulfadiazine.*

*(a) = 0.0 – 9.0 ppm.*

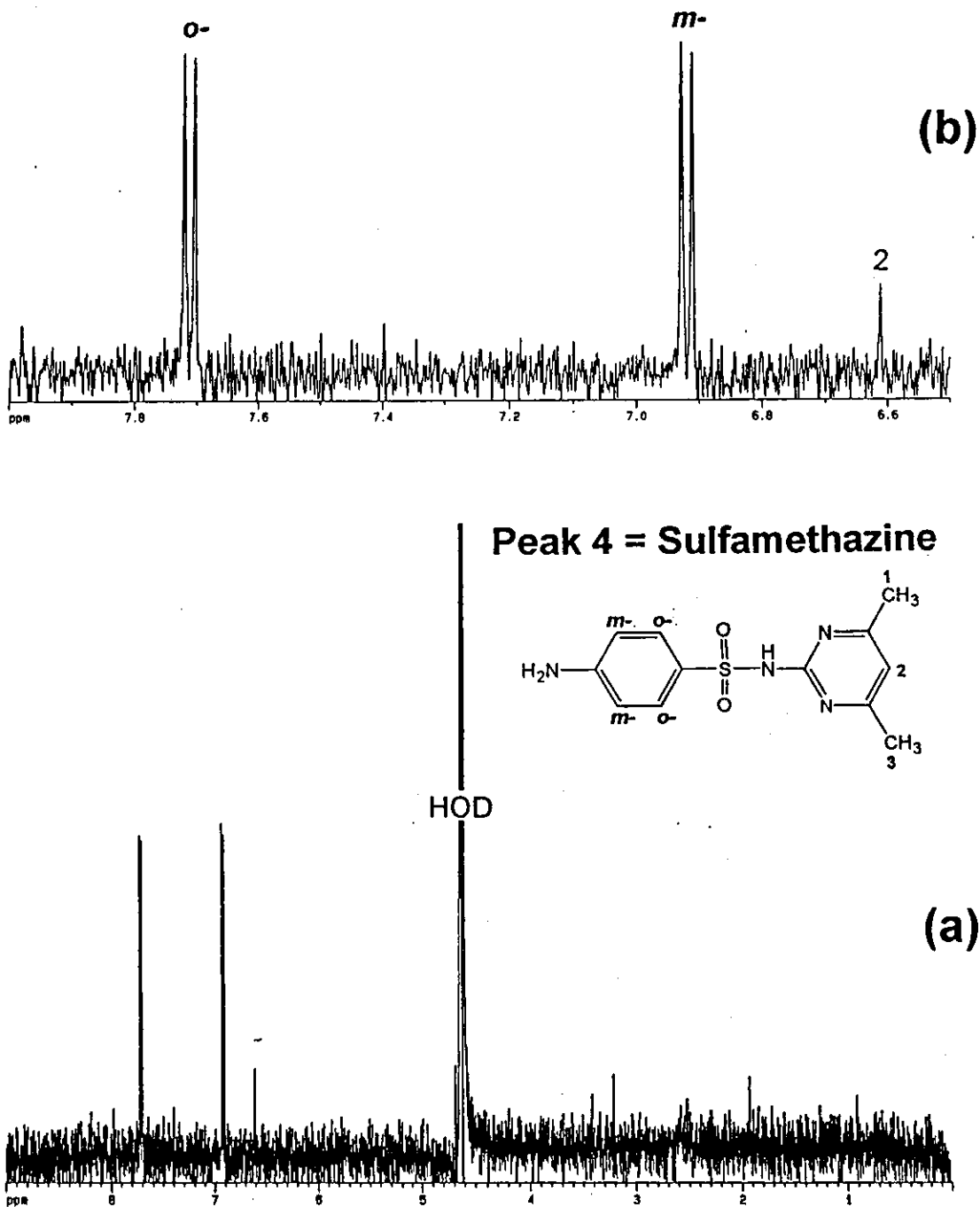
*(b) = Enlargement of the spectrum in a range of 6.5 – 8.5 ppm.*



**Figure 6.7** NMR spectrum obtained using stop-flow mode for the third peak in Figure 6.4, corresponding to sulfamerazine.

(a) = 0.0 – 9.0 ppm.

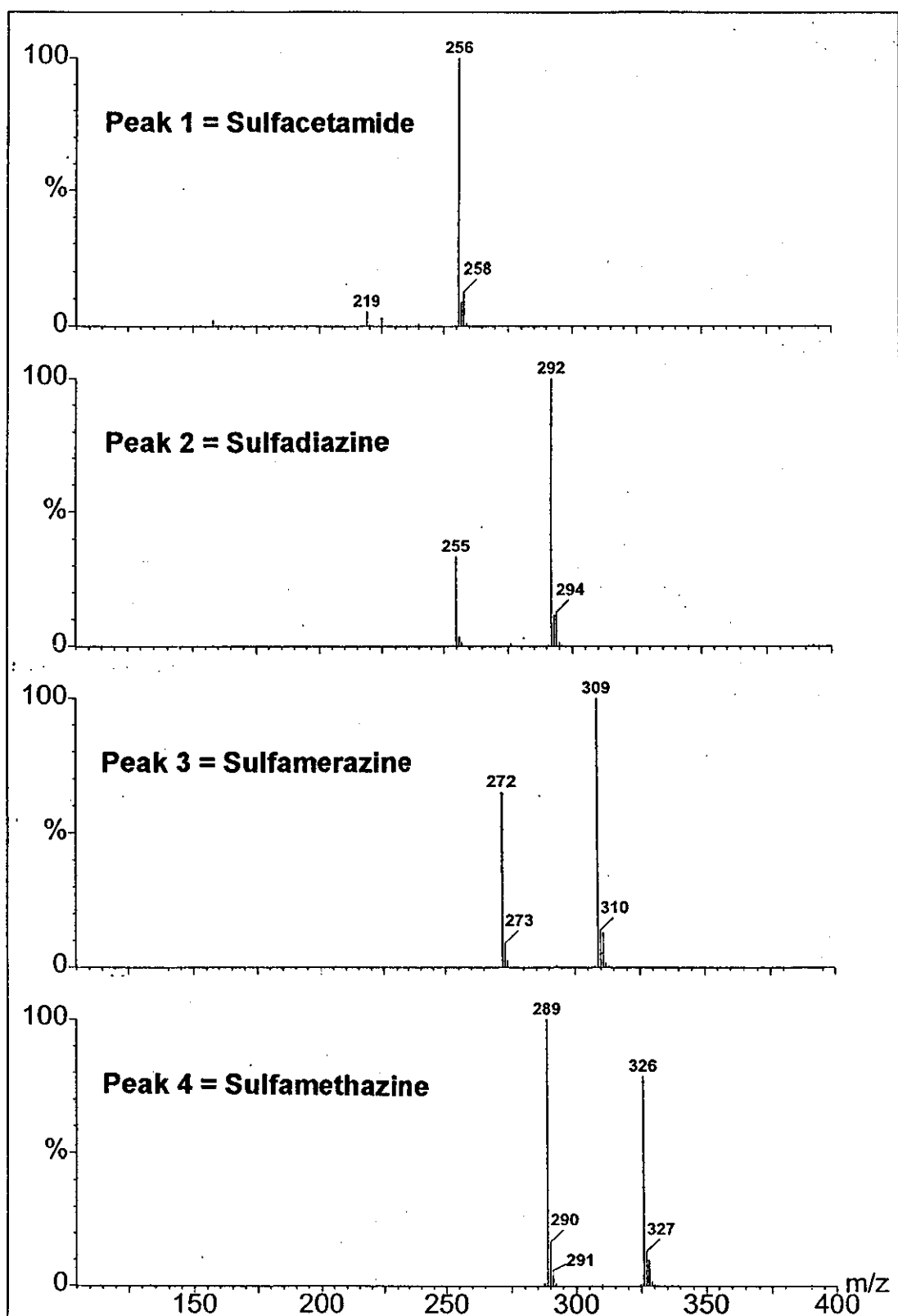
(b) = Enlargement of the spectrum in a range of 6.6 – 8.3 ppm.



**Figure 6.8** NMR spectrum obtained using stop-flow mode for the second peak in Figure 6.4, corresponding to sulfamethazine.

(a) = 0.0 – 9.0 ppm.

(b) = Enlargement of the spectrum in a range of 6.5 – 8.0 ppm.



**Figure 6.9** MS spectra obtained for four sulfonamide mixture separation in pH 3.0 phosphate buffered superheated deuterium oxide.

The NMR spectra of the first and second peaks were interpreted to be sulfacetamide and sulfadiazine, respectively. In acid buffer, the  $\text{NH}_2$  and  $-\text{CO-NH}-$  groups of each sulfonamide were deuterated very quickly. Hence, no signals were observed from those groups.

In Figure 6.5, the acetyl  $\text{CH}_3$  of sulfacetamide gives a strong intensity singlet at 1.9 ppm. Two doublets at 7.65 and 6.8 ppm indicated the *o*- and *m*-hydrogens of aromatic ring. For sulfadiazine (Figure 6.6), those aromatic hydrogens also resonated at similar frequencies, 7.7 (*o*-) and 6.8 (*m*-) ppm. The nitrogens of the pyrimidine ring resulted in a deshielding effect on the attached H1 and H3 hydrogens. As a result, the doublets of H1 and H3 shifted to higher field, 8.35 ppm. In addition, the triplet at 6.95 ppm indicated the H2 of pyrimidine ring. These results agreed with those signals of sulfacetamide and sulfadiazine in the NMR reference spectra [199].

The MS spectra of the first and second peaks also indicated sulfacetamide and sulfadiazine. The molecular mass of sulfacetamide and sulfadiazine are 214 and 250. However, because of the deuterium exchange at  $\text{NH}_2$  and  $-\text{SO}_2\text{-NH}-$  groups, including a  $\text{D}^+$  adduct, the molecular ions appeared at  $m/z$  219 for sulfacetamide and  $m/z$  255 for sulfadiazine. In addition, since the buffer was prepared by using potassium hydrogen phosphate and tripotassium phosphate, a  $\text{K}^+$  adduct of sulfonamides could be formed. Hence, the major peak of sulfacetamide appeared to be  $m/z$  256 and of sulfadiazine at  $m/z$  292.

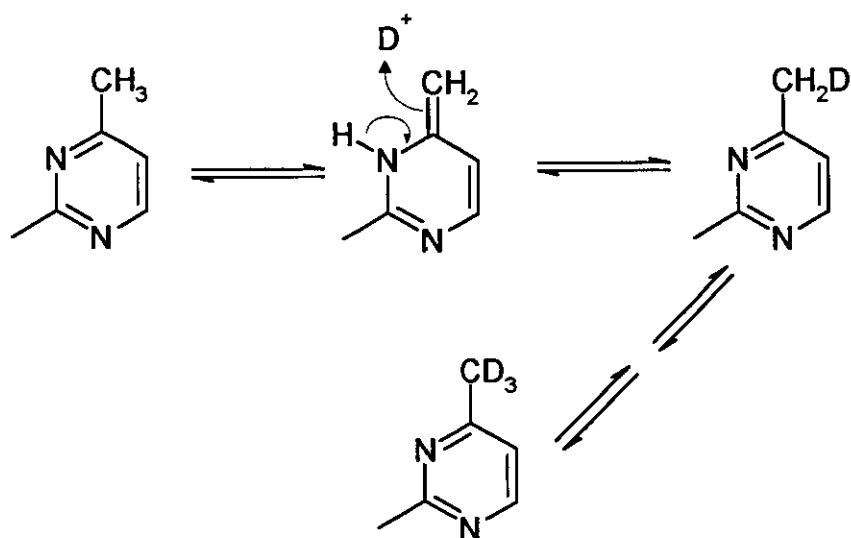
NMR spectra of both the third and fourth peaks (Figures 6.7 and 6.8) showed two doublets at 7.7 and 6.9 ppm that were attributed to *o*- and *m*- aromatic hydrogens of sulfamerazine and sulfamethazine. In Figure 6.7 two doublets at 8.1 and 6.75 ppm were assigned to H1 and H2 of pyrimidine group of sulfamerazine and in Figure 6.8 a singlet at 6.6 ppm was of H2 of sulfamethazine. The fingerprints in aromatic regions were as expected, as

they were similar to the reference NMR spectra [199]. However, the spectrum of sulfamerazine, which was expected to contain a singlet peak for the methyl group of pyrimidine at 2-3 ppm, as given in the reference spectra, showed no such resonance. A similar finding was found for sulfamethazine where there should be two methyl group signals but both were absent.

Interestingly, the MS spectra of the third peak show ions at  $m/z$  272 and 309 and of the fourth peak at  $m/z$  289 and 326. Both masses were higher than expected for sulfamerazine and sulfamethazine molecular mass (264 and 278, respectively) even allowing for the anticipated deuterium exchanges. It was, therefore, suspected that deuteration was occurring not only at the  $\text{NH}_2$  and  $-\text{SO}_2\text{-NH}-$  groups but also at the methyl groups attached to pyrimidine ring of both compounds. Included the  $\text{D}^+$  adduct, the molecular mass would increase to 269 for sulfamerazine and 283 for sulfamethazine. Because of the deuteration of the methyl group(s), the molecular ion of sulfamerazine increased further to  $m/z$  272, and for sulfamethazine to  $m/z$  289. Like sulfacetamide and sulfadiazine, the  $\text{K}^+$  adduct of sulfamerazine and sulfamethazine also contributed to the spectra at  $m/z$  309 and 326, respectively.

The protons of methyl groups at C2, C4 and C6 of pyrimidines are labile and chemically active [215-216], in comparison to those of normal methyl groups on aromatic rings. The deuteration could occur via tautomerisation of the methyl pyrimidine (Figure 6.10). This suggested tautomerism agreed with a study of the base catalysed deuteration of pyrimidine (pH 5-11) by Batterham *et al.* [215]. Other studies revealed that the hydrogens of heteroaromatic compounds could be deuterated under superheated water conditions [217-219], for example at 80-120 °C, 48-52 % of the methyl groups of 2,4,6-trimethylpyridine was deuterated using polymer supported acidic catalysts [218].





**Figure 6.10** A predicted deuteration of methyl group of pyrimidine ring.

The deuteration of methyl group(s) was confirmed by changing the mobile phase to (1:1) buffered deuterium oxide/ $\text{H}_2\text{O}$  and the sulfonamide compounds were detected by mass spectrometer (Figure 6.11). As expected, the sulfonamide mass ions showed peaks with discrepancies for partial deuteration and adduct formation. For example, protonated sulfamerazine, which has  $m/z$  265 without deuteration and  $m/z$  272 with deuteration, gave equal intensity of mass ions at  $m/z$  268 and 269, 167 and 270, 166 and 271, decreasing by size. Whereas the  $\text{K}^+$  adduct ( $m/z$  303 without deuteration and 309 with deuteration) showed the highest intensity peak at  $m/z$  306 which was a result of half deuteration.

The same phenomenon occurred in sulfamethazine. A highest peak at  $m/z$  284 was a result of a half deuteration and  $\text{D}^+$  adduct of sulfamethazine ( $m/z$  279 without deuteration and  $m/z$  289 with deuteration). The peaks at  $m/z$  321 and 322 occurred in the same way when the  $\text{D}^+$  adduct was substituted by  $\text{K}^+$  adduct.

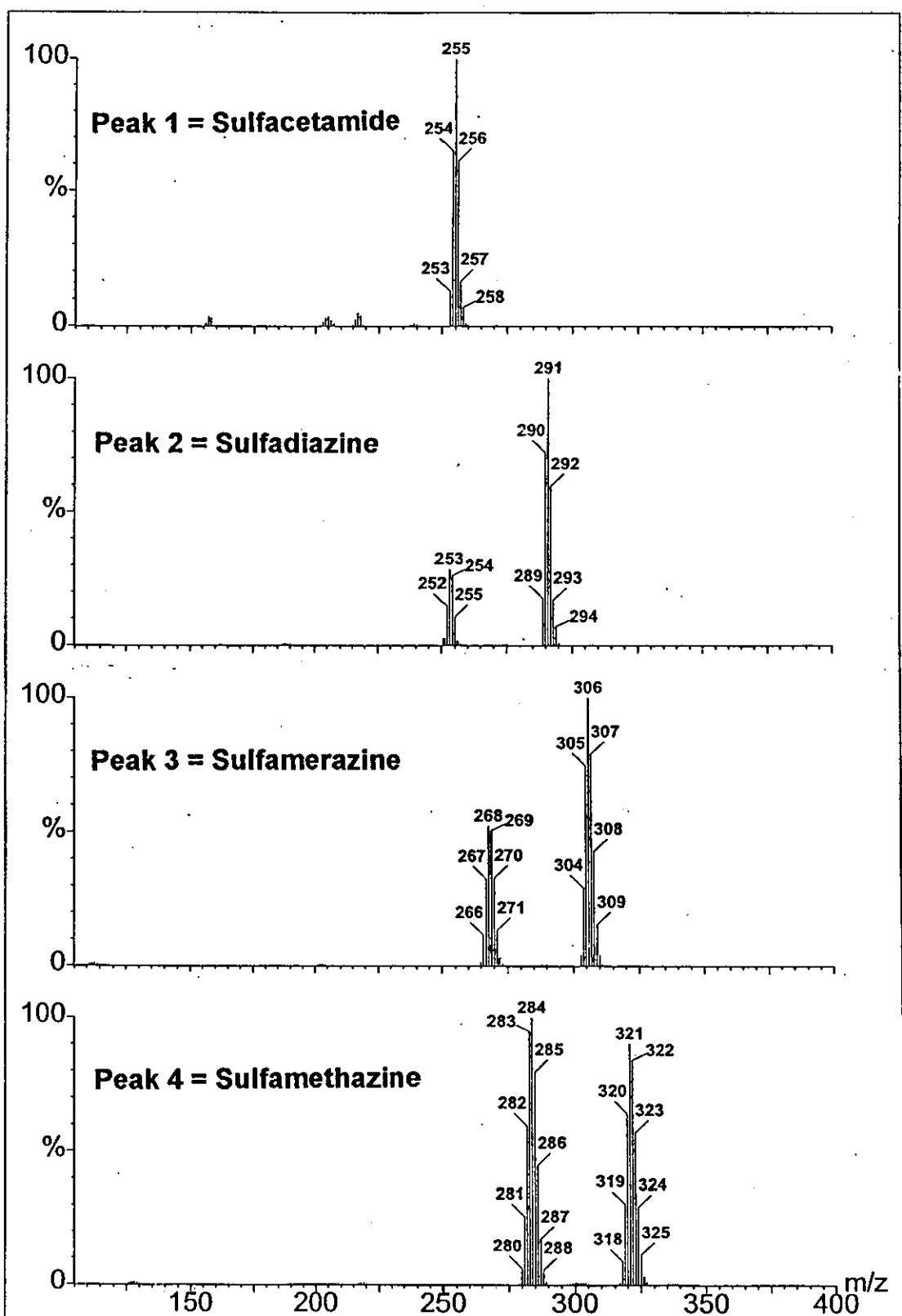
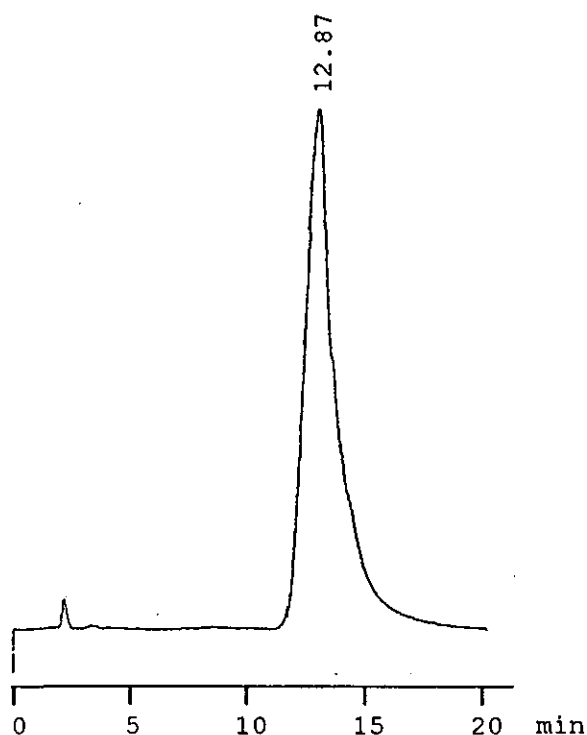


Figure 6.11 MS spectra obtained using (1:1) buffered superheated deuterium oxide – superheated  $H_2O$  as an eluent for four sulfonamide mixture.

For sulfacetamide and sulfadiazine, the deuterium exchange occurred at only  $\text{NH}_2$  and  $-\text{SO}_2-\text{NH}-$  groups, the mass difference between deuterated and non-deuterated compounds was 3 m/z. Hence, sulfadiazine gave the highest intensity of  $\text{D}^+$  and  $\text{K}^+$  adduct peak at m/z 253 and 291, or about a half deuterium exchange (m/z 252 and 289 without exchange and m/z 255 and 292 with exchange), respectively. Similarly, sulfacetamide yielded the  $\text{K}^+$  adduct peak at m/z 255 which was a result of a half of deuterium exchange.

The deuteration of the methyl group of pyrimidine ring was also confirmed by a study of sulfisomidine. Sulfisomidine or  $\text{N}'-(2,6\text{-dimethyl-4-pyrimidinyl})$  sulfanilamide is an isomer of sulfamethazine ( $\text{N}'-(4,6\text{-dimethyl-2-pyrimidinyl})$ sulfanilamide) and was also separated previously by buffered superheated water (Chapter 3). In this experiment, it was chromatographed using deuterated phosphate buffered pH 3.0 at 160 °C, resulting a chromatogram with a peak at 12.87 min (Figure 6.12). Using a stop flow mode, the NMR spectrum was obtained (Figure 6.13). MS detector also detected the peak, yielding a spectrum (Figure 6.14).

The NMR spectrum of sulfisomidine (Figure 6.13) showed similar aromatic resonances to the spectrum of sulfamethazine (Figure 6.8), the two doublets at 7.60 and 6.75 ppm were attributed to *o*- and *m*- aromatic hydrogens and a singlet at 6.5 ppm was assigned to  $\text{H4}'$  of pyrimidine ring. Nevertheless, a singlet at 1.9 ppm seemed to be due to partially deuterated methyl groups of pyrimidine ring ( $\text{H1}'$  and  $\text{H3}'$ ), since it showed one singlet instead of two singlets [199] and the signal was weaker than expected without deuteration. The MS spectrum also confirmed the deuteration, as shown the m/z 289 and 326, which were the same mass ions as those of deuterated sulfamethazine (Figure 6.9). The m/z 289 was a  $\text{D}^+$  adduct of sulfisomidine deuterated at  $\text{NH}_2$  and  $-\text{SO}_2-\text{NH}-$  and two methyl groups of pyrimidine ring. In addition, the m/z 326 was a  $\text{K}^+$  adduct of the deuterated sulfisomidine.



**Figure 6.12** Chromatogram of 106  $\mu\text{g}$  sulfisomidine on column

**Chromatographic conditions:** column, 5  $\mu\text{m}$  PS-DVB column; mobile phase, deuterated phosphate buffer pH 3.0 at flow rate 1.0  $\text{ml min}^{-1}$ ; oven temperature 160  $^{\circ}\text{C}$ ; UV absorption, 254 nm; transfer time between UV and NMR, 33 s.

It can be concluded that the deuteration occurred at  $\text{NH}_2$  and  $-\text{SO}_2\text{-NH}-$  and two methyl groups of pyrimidine ring of sulfanilamide derivatives under superheated water conditions, as the NMR resonances in the expected region were very weak or disappeared. MS spectra also confirmed the reaction, as shown the ions with extra masses from deuteration. On-line NMR and MS technique worked perfectly and provided very useful information for the reaction that happened.

It should be noted that if the experiment was repeated using off-line mode NMR, we found the deuterated methyl groups were stable at room temperature and did not exchange back even in undeuterated water [115].

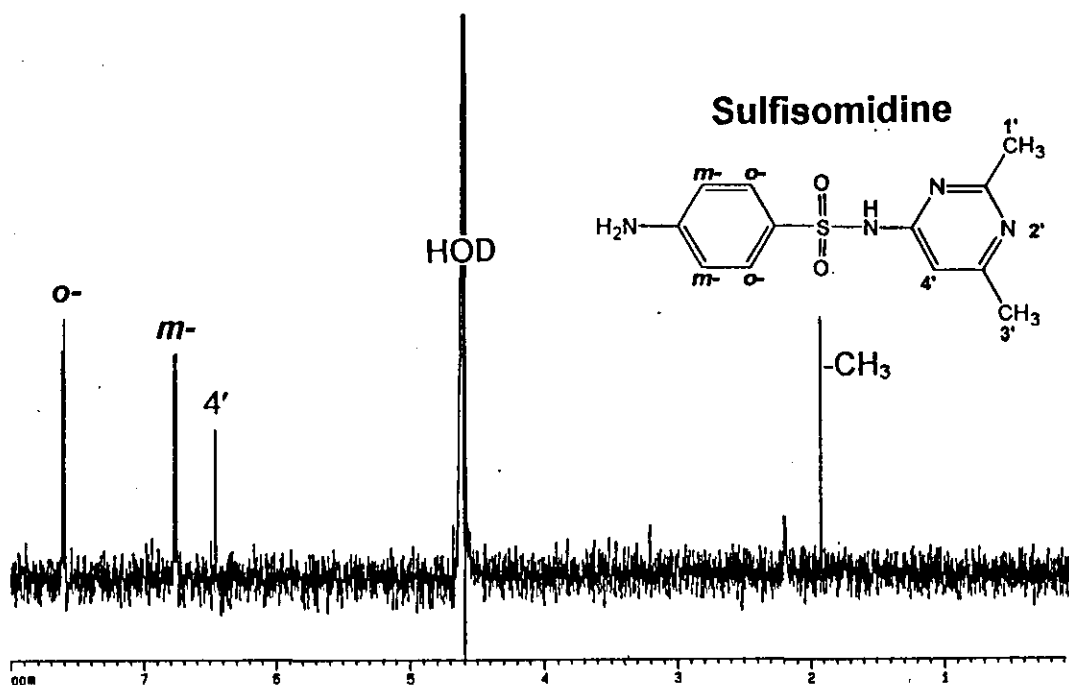


Figure 6.13 NMR spectrum obtained using stop-flow mode for sulfisomidine in Figure 6.12.

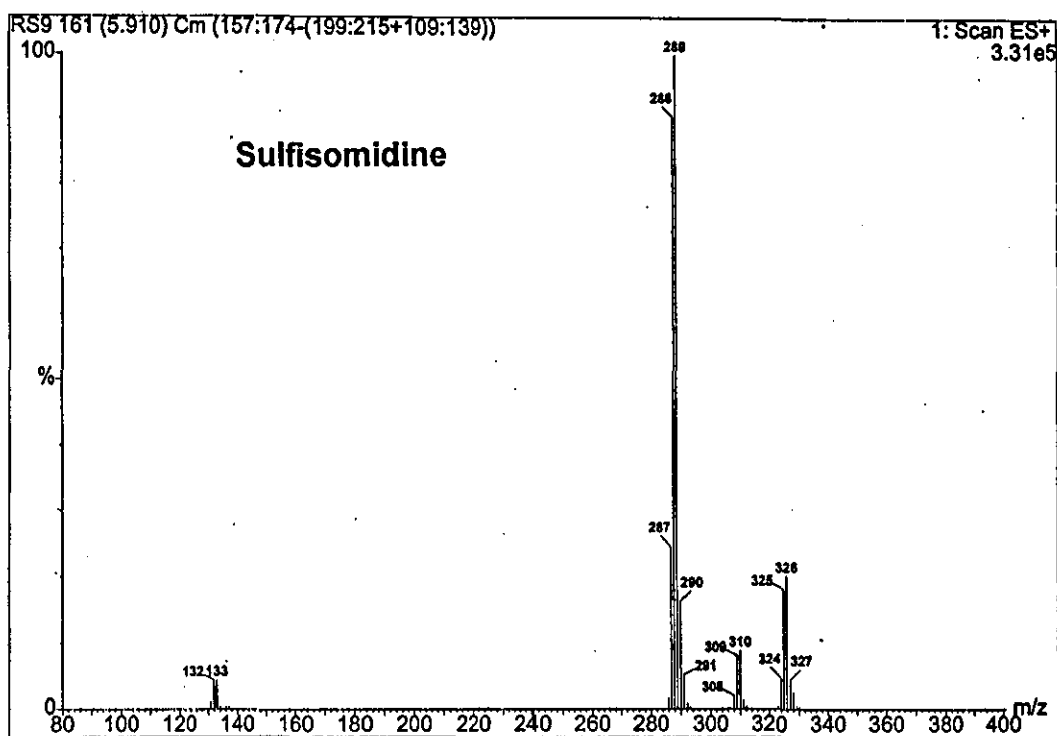


Figure 6.14 MS of sulfisomidine separated by buffered superheated deuterium oxide pH 3.0 in Figure 6.12.

## 6.4 Application to thiamine

Thiamine, an essential vitamin B, contains pyrimidine and thiazole groups linked by a methylene bridge as the structure shown in Figure 4.19 and Figure 6.17. Thiamine was separated using superheated water chromatography with fluorescence detection as previously mentioned in section 4.1.2. According to the difference in retention time of the major peak detected by UV and fluorescence, it was thought that the two signals were the result of the oxidation of thiamine to thiochrome and that the two different compounds respond in the different detectors.

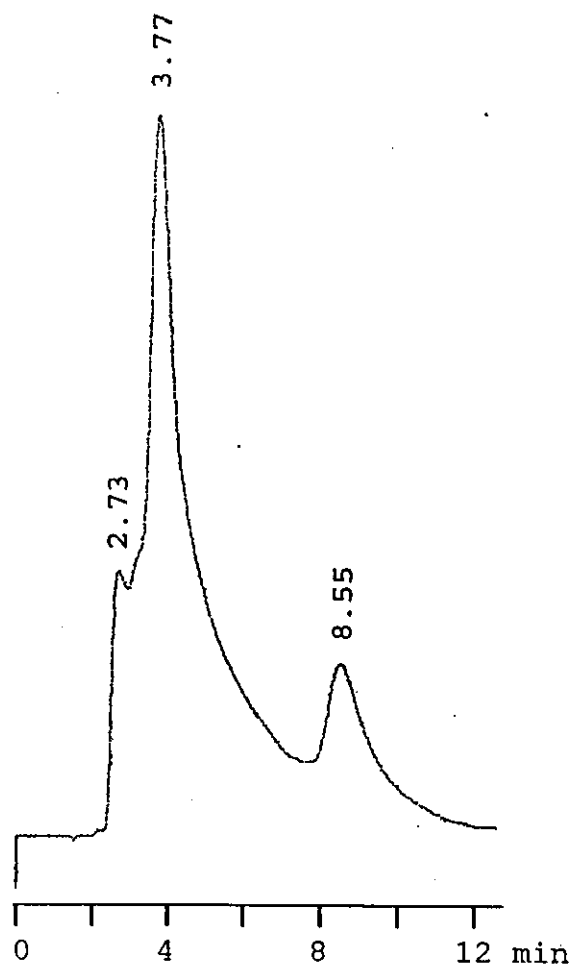
Thiamine is decomposed by heat or in basic solution [179]. Its degradation generates more than 60 products, some contain aromas and many of them remained unidentified [220-221]. A list of several degraded products has been reported [220-223].

### 6.4.1 Separation at 160 °C with buffered superheated deuterium oxide

Freshly prepared thiamine was re-examined on the superheated water chromatography-NMR-MS system at 160 °C (Figure 6.15), resulting a chromatogram with a big tailing peak at 3.77 min slightly overlapping with a small tailing peak at 8.55 min. By using a stop flow mode for the main peak at 3.77 min, the NMR spectrum was obtained (Figure 6.16). When the flow was started again, MS detection was performed and a spectrum obtained (Figure 6.18).

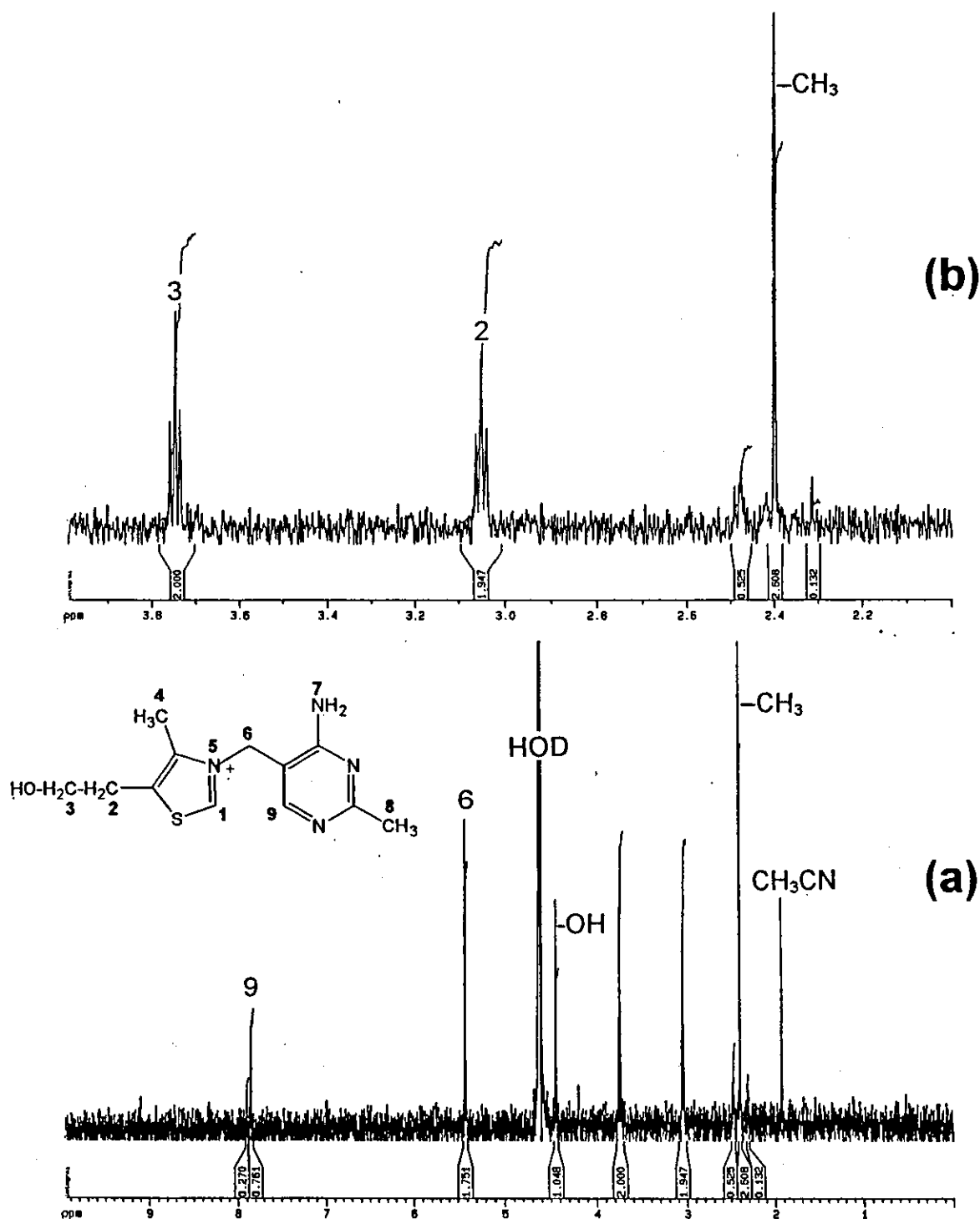
The NMR spectrum of pure thiamine in cold deuterium oxide without the superheated water separation (Figure 6.17) was also measured and all the resonances matched the reference NMR spectrum [199]. The resonances were assigned: two singlets at 2.5 and 2.6 ppm (methyl H4 and H8 of thiazole

and pyrimidine ring), two triplets at 3.2 and 3.8 ppm (H2 and H3 of ethanolic group), three singlets at 5.5 ppm (H6 of methylene bridge), 8.0 ppm (H9 of pyrimidine ring) and 9.7 ppm (H1 of thiazole ring).



**Figure 6.15** Chromatogram of 105  $\mu\text{g}$  thiamine on column eluted by deuterated phosphate buffer pH 3.0.

**Chromatographic conditions:** column: 5  $\mu\text{m}$  PS-DVB column; mobile phase, deuterated phosphate buffer pH 3.0 at flow rate 1.0  $\text{ml min}^{-1}$ ; oven temperature 160  $^{\circ}\text{C}$ ; UV absorption, 254 nm; transfer time between UV and NMR, 33 s.

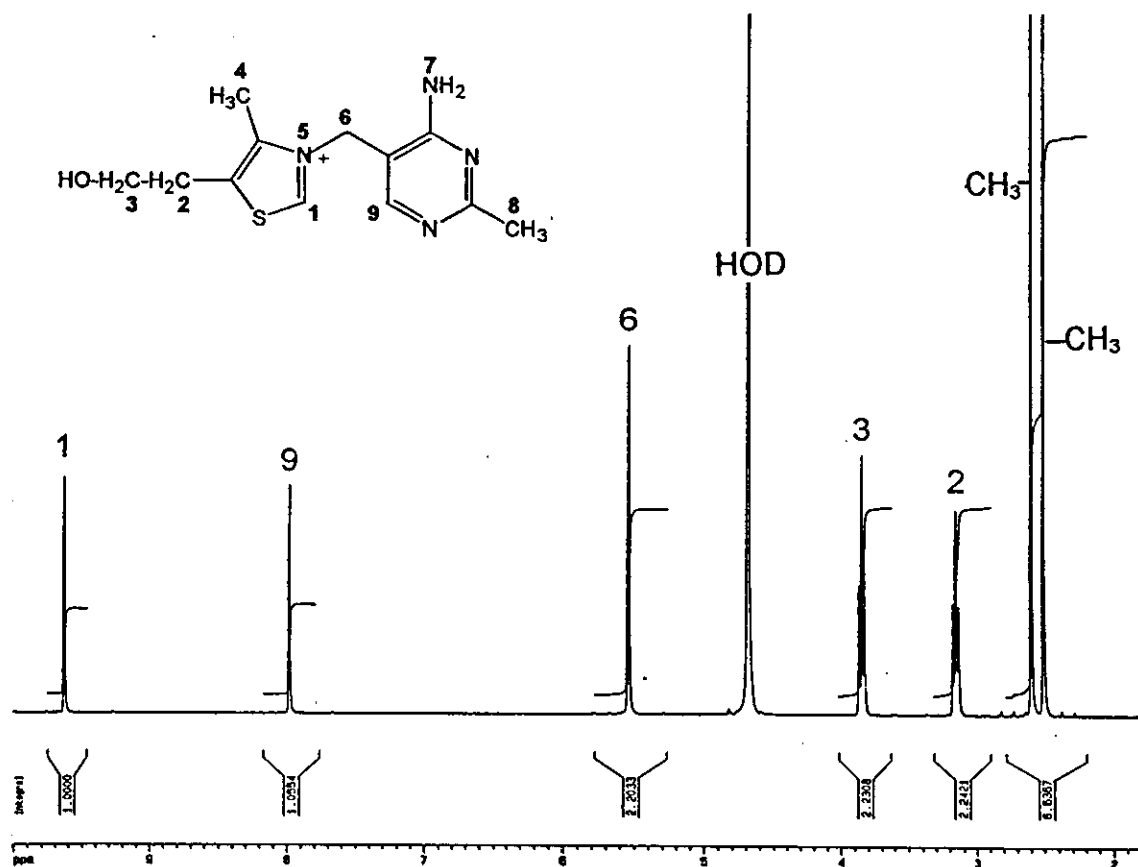


**Figure 6.16** NMR spectrum obtained using stop-flow mode for the first large peak in Figure 6.15.

(a) = 0.0 – 10.0 ppm.

(b) = Enlargement of the spectrum in a range of 2.0 – 4.0 ppm.





**Figure 6.17** NMR spectrum of pure thiamine.

The resonances of the separated thiamine NMR spectrum (Figure 6.16) were then compared to those of non-separated thiamine spectrum. Similar resonances were found: two triplets at 3.05 ppm (H2) and 3.75 ppm (H3), two singlets at 5.45 ppm (H6) and 7.85 ppm (H9), and a singlet of methyl H4. Interestingly, the resonances of H1 (hydrogen of thiazole ring) and H8 (methyl group of pyrimidine ring), which had been expected at ~9.5 and ~2.6 ppm, respectively, were absent. It was believed that those two groups were deuterated because methyl protons of pyrimidine ring (H8) were labile and active for deuteration [215], as happened to sulfonamides in the previous section, and H1 was also labile.

Mass spectra were measured at different retention times (Figure 6.18 a-c). At 3.56 min, it showed  $m/z$  144, 145, 146 and 172 (Figure 6.18 a), and at 4.26 min the ions at  $m/z$  136, 146, 147 and 269-274 were analysed (Figure 6.18 b). Scanned at 7.85 min (Figure 6.18 c), higher mass at  $m/z$  161, 177, 283, and 299 were detected.

In order to assign the peaks in Figure 6.18, the MS spectrum of pure thiamine without separation was obtained. Fresh prepared thiamine in  $D_2O$  was directly introduced to the MS, resulting in two main peaks of thiamine molecular ion ( $[C_{12}H_{17}N_4OS]^+$ ,  $m/z$  265) and its fragmented ion ( $m/z$  144) (Figure 6.19). The small peaks at  $m/z$  266, 267, and 268 were likely to be the first, second and third deuterium exchange of thiamine at H7 of amino and -OH of ethanolic group. A very small peak at  $m/z$  287 was a  $Na^+$  adduct of deuterated thiamine, as sodium phosphate buffer was used. Since thiamine can be decomposed to generate a major product, 4-methyl-5-thiazoleethanol ( $C_6H_9NS$ ,  $m/z$  143) [179], the peak at  $m/z$  144 seemed to be the mass of protonated 4-methyl-5-thiazoleethanol ( $[C_6H_{10}NS]^+$ ). In addition, the product was deuterated, showing  $m/z$  145, 146, and 147. The  $m/z$  122 corresponded to the mass of the pyrimidine fragment.

A mass spectrum of 4-methyl-5-thiazoleethanol in  $D_2O$  buffer was also investigated (Figure 6.20). By directly introducing the solution to the MS, the result showed a main peak at  $m/z$  146 which was thought to be a result of a deuterium exchange at the ethanolic group and  $D^+$  adduct of 4-methyl-5-thiazoleethanol,  $[C_6H_8D_2NS]^+$ . The  $Na^+$  and  $K^+$  adduct were also formed, giving  $m/z$  167 and 183, as sodium and potassium hydrogen phosphate buffer were used.

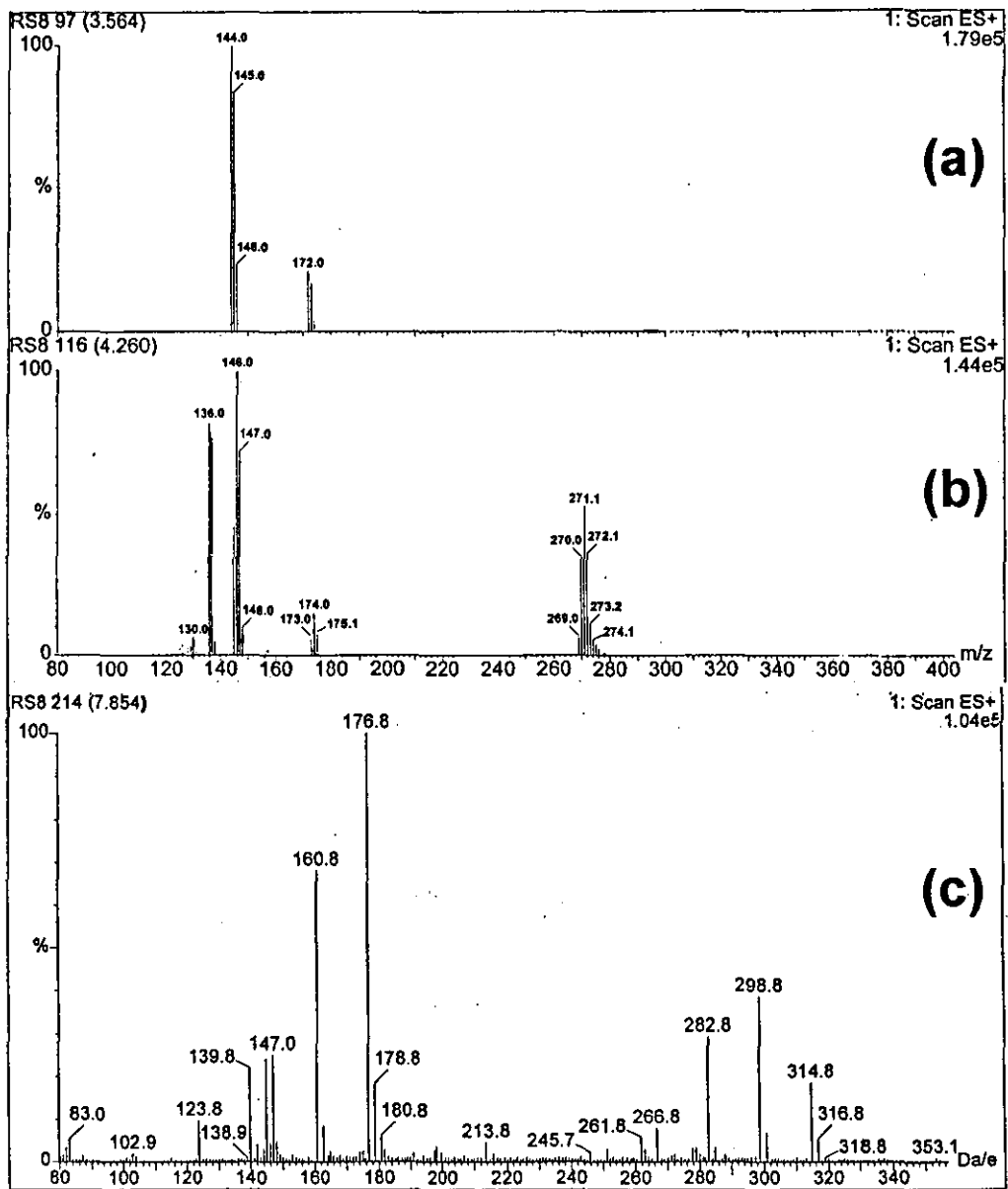


Figure 6.18 a-c MS spectra obtained for the first large peak (a and b) and the second following peak (c) in Figure 6.15.

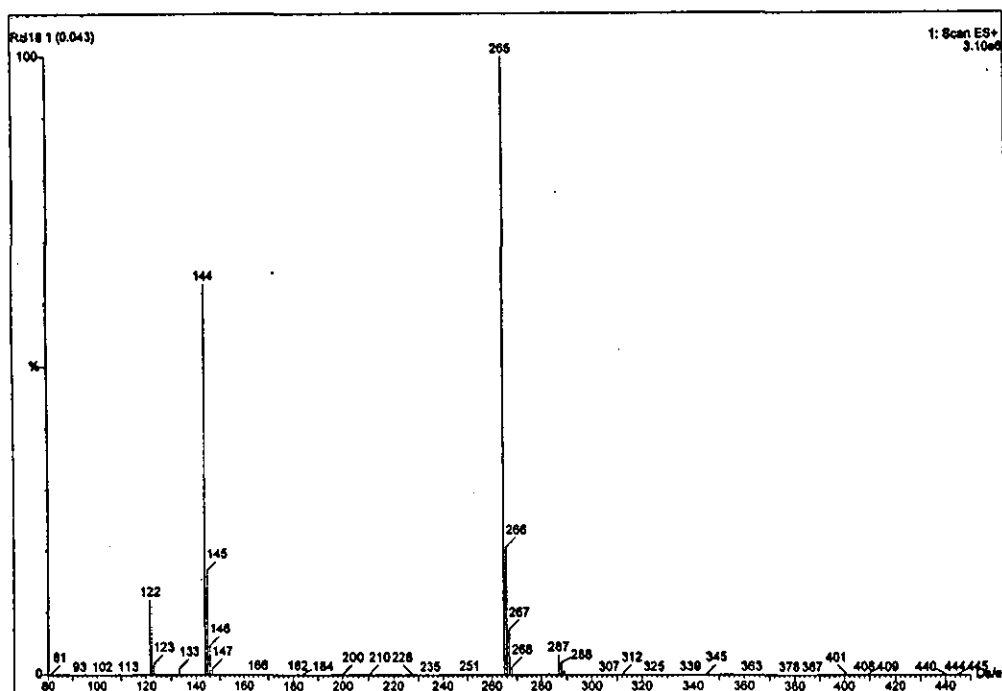


Figure 6.19 MS spectra of thiamine in deuterated phosphate buffer pH 3.0 and injected directly to MS.

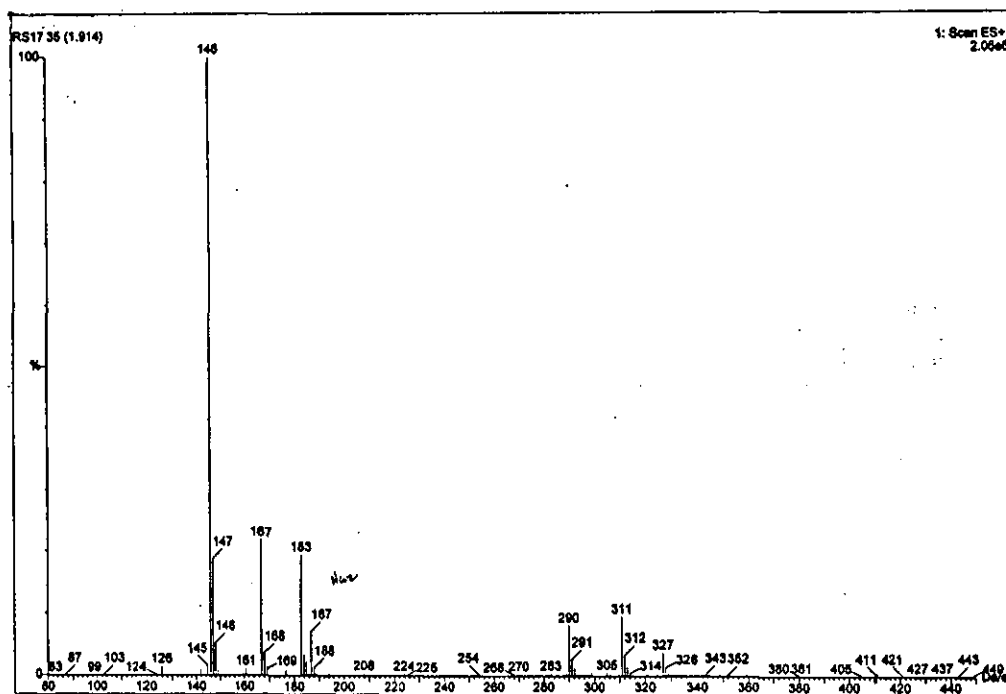
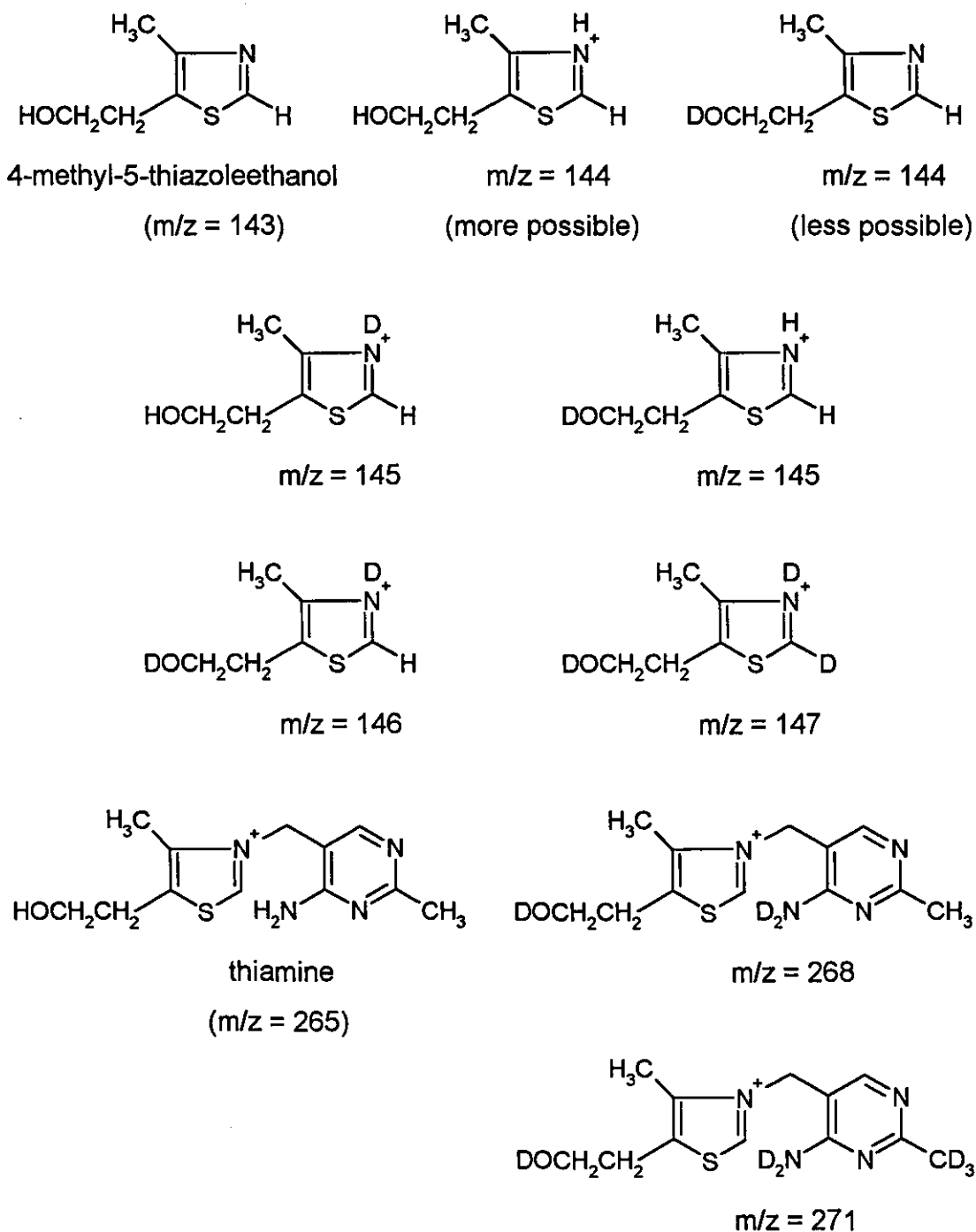


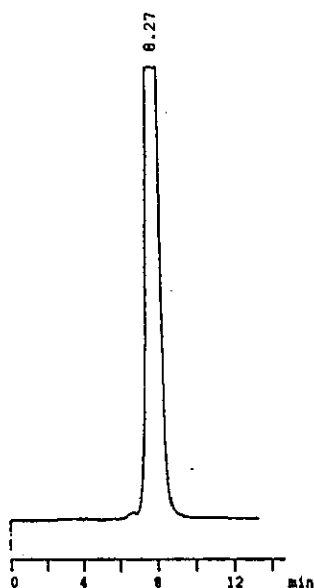
Figure 6.20 MS spectrum of 4-methyl-5-thiazoleethanol in deuterated phosphate buffer pH 3.0 and injected directly to MS.

Hence, by comparing the peaks of the MS spectrum in Figure 6.18 (a-b) with those of Figure 6.19 and 6.20, the  $m/z$  144 was a protonated 4-methyl-5-thiazoleethanol ( $[C_6H_{10}NS]^+$ ), whereas,  $m/z$  145 and 146 were its deuterated products and  $D^+$  adduct  $[C_6H_9DNS]^+$  and  $[C_6H_8D_2NS]^+$ . The  $m/z$  147 could occur from deuteration at the ethanolic group and H1 hydrogen of thiazole ring, including a  $D^+$  adduct,  $[C_6H_7D_3NS]^+$ . As there was trace of methanol in the mobile phase, the  $m/z$  172 was thought to be a formylation of 4-methyl-5-thiazoleethanol, however, there was no further evidence for this addition. Figure 6.18 b also showed ions at  $m/z$  269-274 which confirmed that molecular thiamine existed after the separation. The  $m/z$  271 peak corresponded to  $([C_{12}H_{11}D_6N_4OS]^+)$  that indicated deuteration at the methyl group of pyrimidine (H8), amino hydrogen (H7) and ethanolic hydrogen. The  $m/z$  136 ion could not be identified. In Figure 6.18 c, two main peaks at  $m/z$  177 and 299 were thought to be formylation of 4-methyl-5-thiazoleethanol and thiamine, respectively. However, the other peaks remained unidentified, since they were not matched the reported thiamine degraded products [220-223].



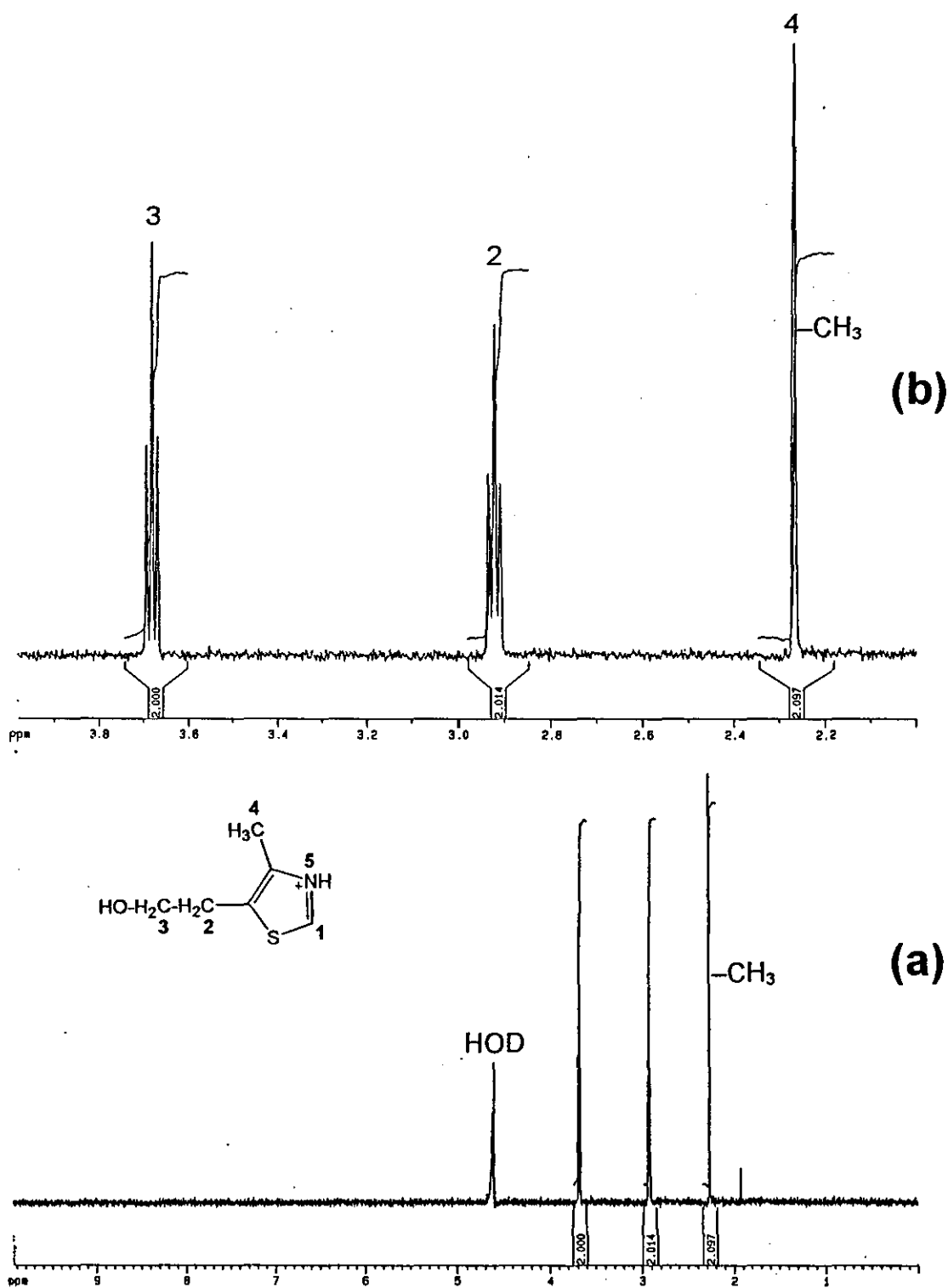
**Figure 6.21** Thiamine and 4-methyl-5-thiazoleethanol and their deuterated product.

The separation of 4-methyl-5-thiazoleethanol by buffered superheated deuterium oxide and on-line detection by NMR and MS was also studied. The experiment was carried out by introducing 4-methyl-5-thiazoleethanol solution in phosphate buffer to the system at 160 °C. The resulting UV chromatogram showed only one large peak with a retention at 8.27 min (Figure 6.21). The NMR spectrum (Figure 6.22) exhibited two triplets of the ethanolic group at 2.9 ppm (H2) and 3.7 ppm (H3), and a singlet of methyl group (H4) at 2.25 ppm. All resonances matched the reference NMR spectrum of 4-methyl-5-thiazole-ethanol [199], except two singlets at ~8.5 ppm (-OH) and at ~4.0 ppm (H1) were absent. Since the hydroxy hydrogen and H1 were labile, it was postulated that deuterium exchange occurred at both positions. This confirmed by the MS spectra of 4-methyl-5-thiazoleethanol (Figure 6.23) which gave only one peak at  $m/z$  147 of a  $D^+$  adduct of deuterated 4-methyl-5-thiazoleethanol,  $[C_8H_7D_3NS]^+$ .



**Figure 6.22** Chromatogram of 100  $\mu$ g 4-methyl-5-thiazoleethanol on column eluted by deuterated phosphate buffer pH 3.0.

**Chromatographic conditions:** 5  $\mu$ m PS-DVB column; mobile phase, deuterated phosphate buffer pH 3.0 at flow rate 1.0 ml  $min^{-1}$ ; oven temperature 160 °C; UV absorption, 254 nm; transfer time between UV and NMR, 33 s.

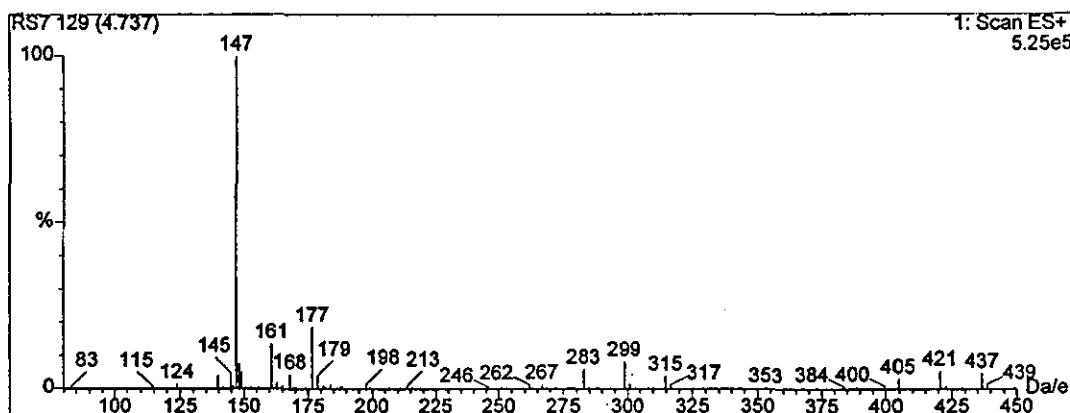


**Figure 6.23** NMR spectrum obtained using stop-flow mode for 4-methyl-5-thiazoleethanol in Figure 6.21.

(a) = 0.0 – 10.0 ppm.

(b) = Enlargement of the spectrum in a range of 2.0 - 4.0 ppm.





**Figure 6.24** MS spectra obtained for 4-methyl-5-thiazoleethanol separated by buffered superheated deuterium oxide in Figure 6.21.

It was concluded that under buffered superheated water conditions at 160 °C, thiamine was partly degraded on the column, resulting in 4-methyl-5-thiazoleethanol. The main peak (3.77 min) on the chromatogram showed that thiamine was the main constituent but it was deuterated at  $-\text{NH}_2$ ,  $-\text{OH}$ , and methyl hydrogens of pyrimidine ring. The methyl hydrogens of pyrimidine are also very active [215], as detailed in the previous section. This was confirmed by the NMR spectrum. When introduced to the ES-MS, (deuterated) thiamine was further degraded to (deuterated) 4-methyl-5-thiazoleethanol and some unidentified products. It could not be determined if the deuteration was taking place before the degradation or afterwards.

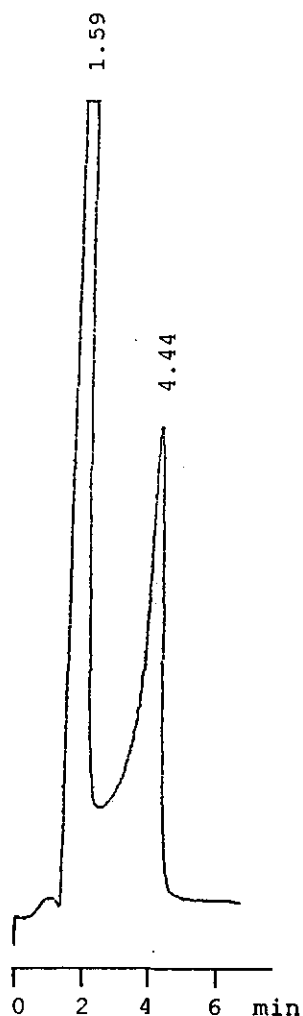
#### 6.4.2 Separation at 190 °C with buffered superheated deuterium oxide

The experiment was further investigated by raising the temperature to 190 °C. Freshly prepared thiamine was chromatographed, resulting a major large peak (1.59 min) and a fronting minor peak (4.44 min) (Figure 6.25).

The NMR measurement could be only obtained from the first large peak of chromatogram (Figure 6.26). By comparing the resonances of separated thiamine (Figure 6.16) and the separated 4-methyl-5-thiazoleethanol (Figure 6.22), it was thought that this peak contained a mixture of thiamine and 4-methyl-5-thiazoleethanol and the spectrum was a result of an overlap of the two spectra. The resonances were assigned for deuterated thiamine at singlets at 5.4 (H6) and 7.9 (H9) ppm and the triplets at 3.05 (H2) and 3.75 (H3) ppm, whereas, a singlet at 2.35 (H4), two triplets at 3.0 (H2) and 3.7 (H3) ppm were of 4-methyl-5-thiazoleethanol. This was confirmed by MS spectra in Figure 6.27 a, the large peak at 1.59 min on the chromatogram contained  $m/z$  144, 145, and 146, which were protonated and deuterated 4-methyl-5-thiazoleethanol, and  $m/z$  269-272, which were deuterated thiamine.

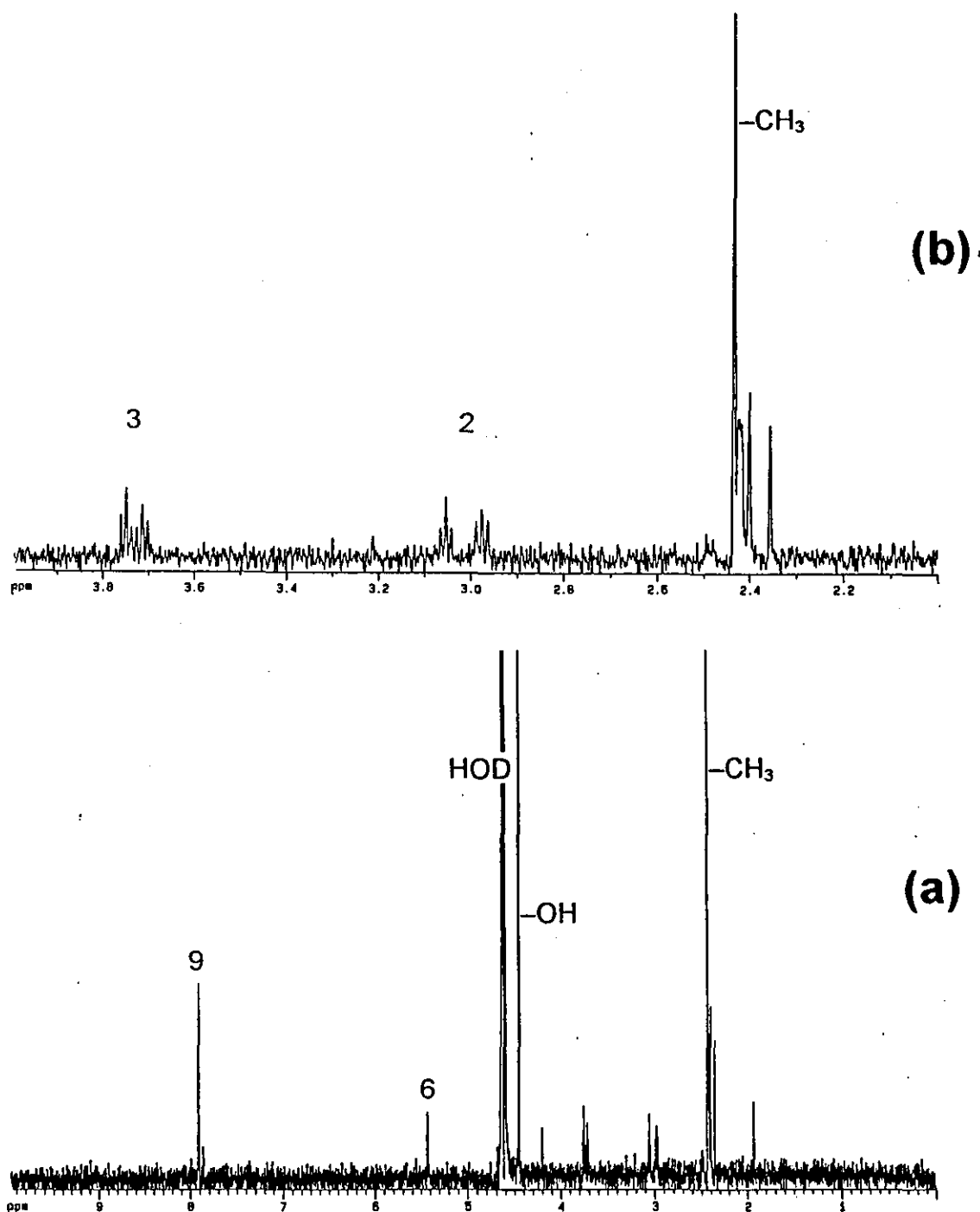
Figure 6.27 b is the MS spectrum of the second fronting peak at 4.44 min on the chromatogram in Figure 6.25. It is obviously seen that there was only one component in the peak. It was deuterated 4-methyl-5-thiazoleethanol, as its  $D^+$  adduct showed  $m/z$  147.

It can be summarised that in phosphate buffer pH 3.0 at 190 °C, thiamine was degraded and separated, resulting the first large peak which contained a mixture of deuterated thiamine and protonated 4-methyl-5-thiazoleethanol, whereas, and the second peak contained only deuterated 4-methyl-5-thiazoleethanol.



**Figure 6.25** Chromatogram of 100  $\mu\text{g}$  thiamine on column eluted by deuterated phosphate buffer pH 3.0.

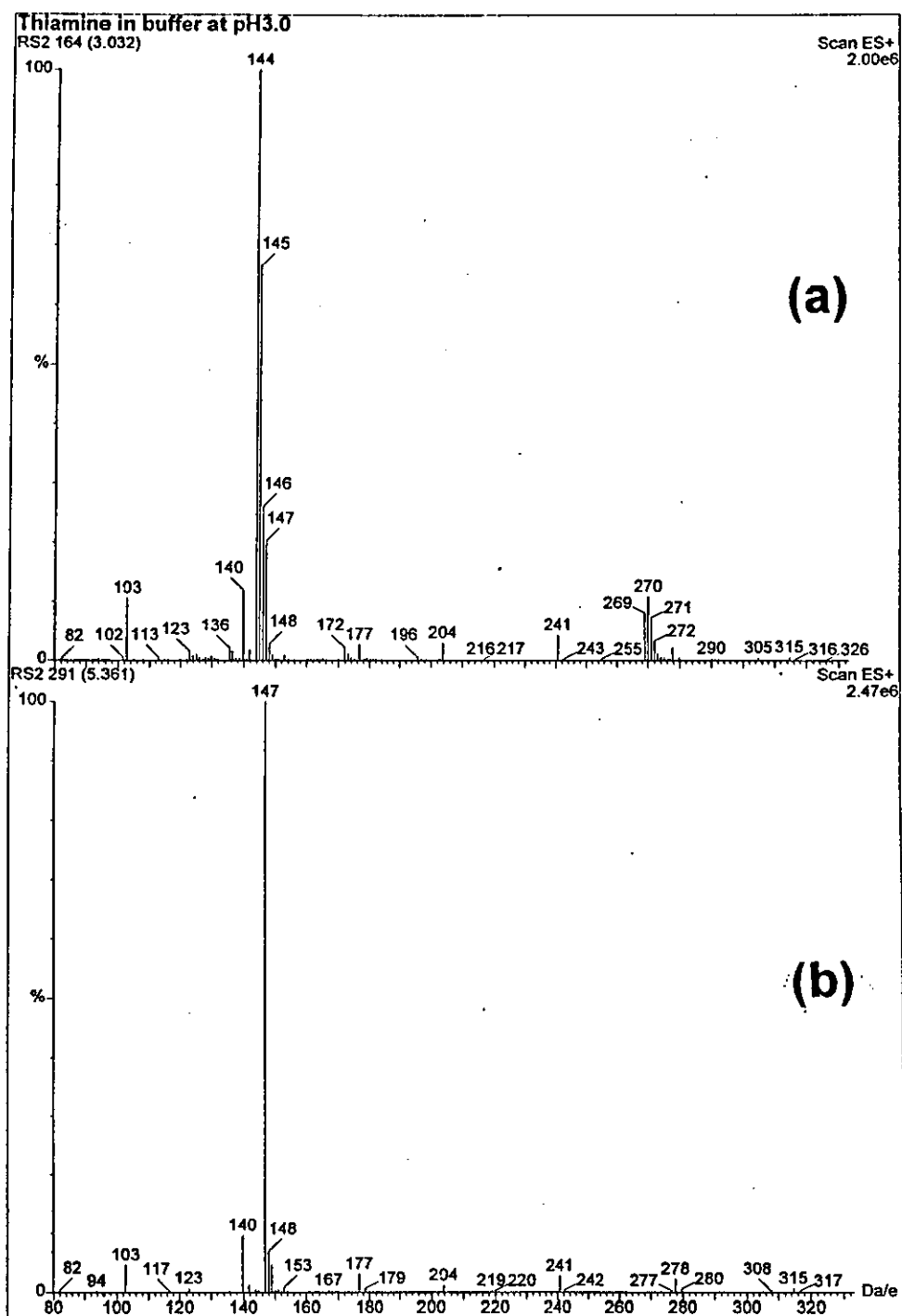
**Chromatographic conditions:** column, 5  $\mu\text{m}$  PS-DVB column; mobile phase, deuterated phosphate buffer pH 3.0 at flow rate 1.0  $\text{ml min}^{-1}$ ; oven temperature 190  $^{\circ}\text{C}$ ; UV absorption, 254 nm; transfer time between UV and NMR, 33 s.



**Figure 6.26** NMR spectrum obtained using stop-flow mode for the first large peak in Figure 6.24.

(a) = 0.0 – 10.0 ppm.

(b) = Enlargement of the spectrum in a range of 2.0 – 4.0 ppm.



**Figure 6.27** MS spectra of the first and second peak of thiamine hydrochloride separated in buffered superheated deuterium oxide at 190 °C in Figure 6.24.

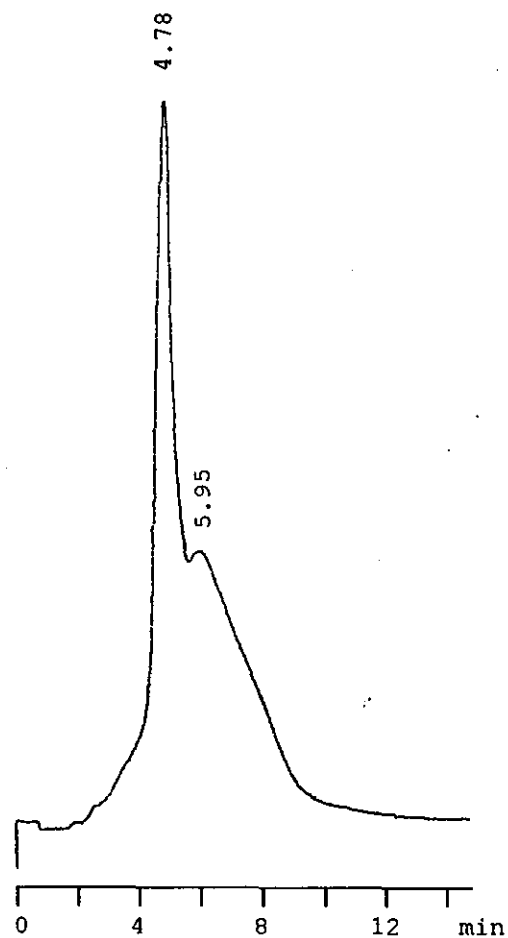
(a) = The first large peak

(b) = The second peak

### 6.4.3 Separation at 190 °C with unbuffered superheated deuterium oxide

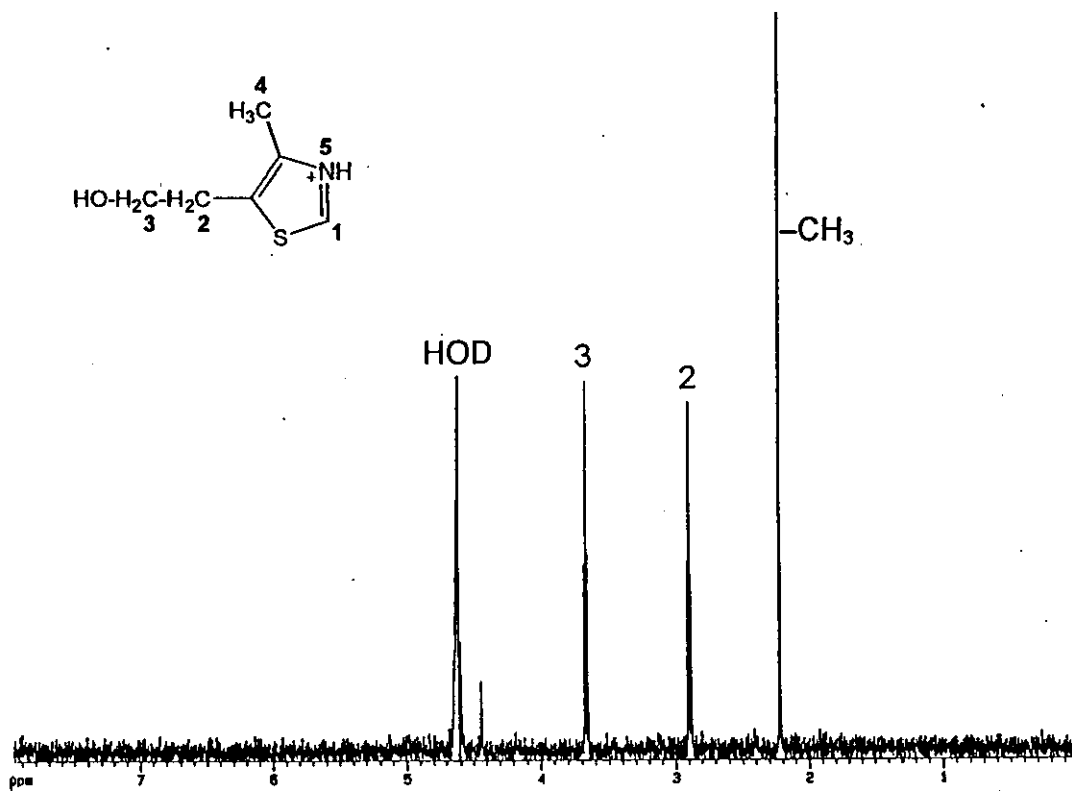
Further investigation was carried out using pure superheated deuterium oxide mobile phase at 190 °C. The resulting UV chromatogram of thiamine showed a major peak (4.78 min) overlapping with an unresolved smaller broad peak (5.95 min) (Figure 6.28). The NMR measurement could be performed only on the major peak, yielding a spectrum (Figure 6.29) whose fingerprint was exactly the same as that of deuterated 4-methyl-5-thiazoleethanol spectrum (Figure 6.22). The second broad peak (5.95 min) of the chromatogram gave very weak NMR signal, therefore, it could not be identified. The main component contained in the major peak was, therefore, deuterated 4-methyl-5-thiazoleethanol which was confirmed by MS spectrum of the major peak with  $m/z$  147, (Figure 6.30 a).

The mass spectrometer could detect peaks of  $m/z$  268, 269 and 270 (which corresponded to deuterated thiamine) at 5.6 min after the first peak detection. Intensities of these peaks were approximately 20 times lower than of 4-methyl-thiazoleethanol. This suggests that *ca.* 95% thiamine had been degraded and deuterated during the separation in superheated deuterium oxide at 190 °C, resulting in the product, deuterated 4-methyl-thiazoleethanol which was eluted as the first major peak. While a small amount (~5%) of thiamine remained undegraded and was separated later as deuterated thiamine.



**Figure 6.28** Chromatogram of 105  $\mu\text{g}$  thiamine on column eluted by deuterium oxide.

**Chromatographic conditions:** column, 5  $\mu\text{m}$  PS-DVB column; mobile phase, deuterium oxide at flow rate 1.0  $\text{ml min}^{-1}$ ; oven temperature 190  $^{\circ}\text{C}$ ; UV absorption, 254 nm; transfer time between UV and NMR, 33 s.; MS split ratio, 20:1.



**Figure 6.29** NMR spectrum obtained using stop-flow mode for the first major peak in Figure 6.27.



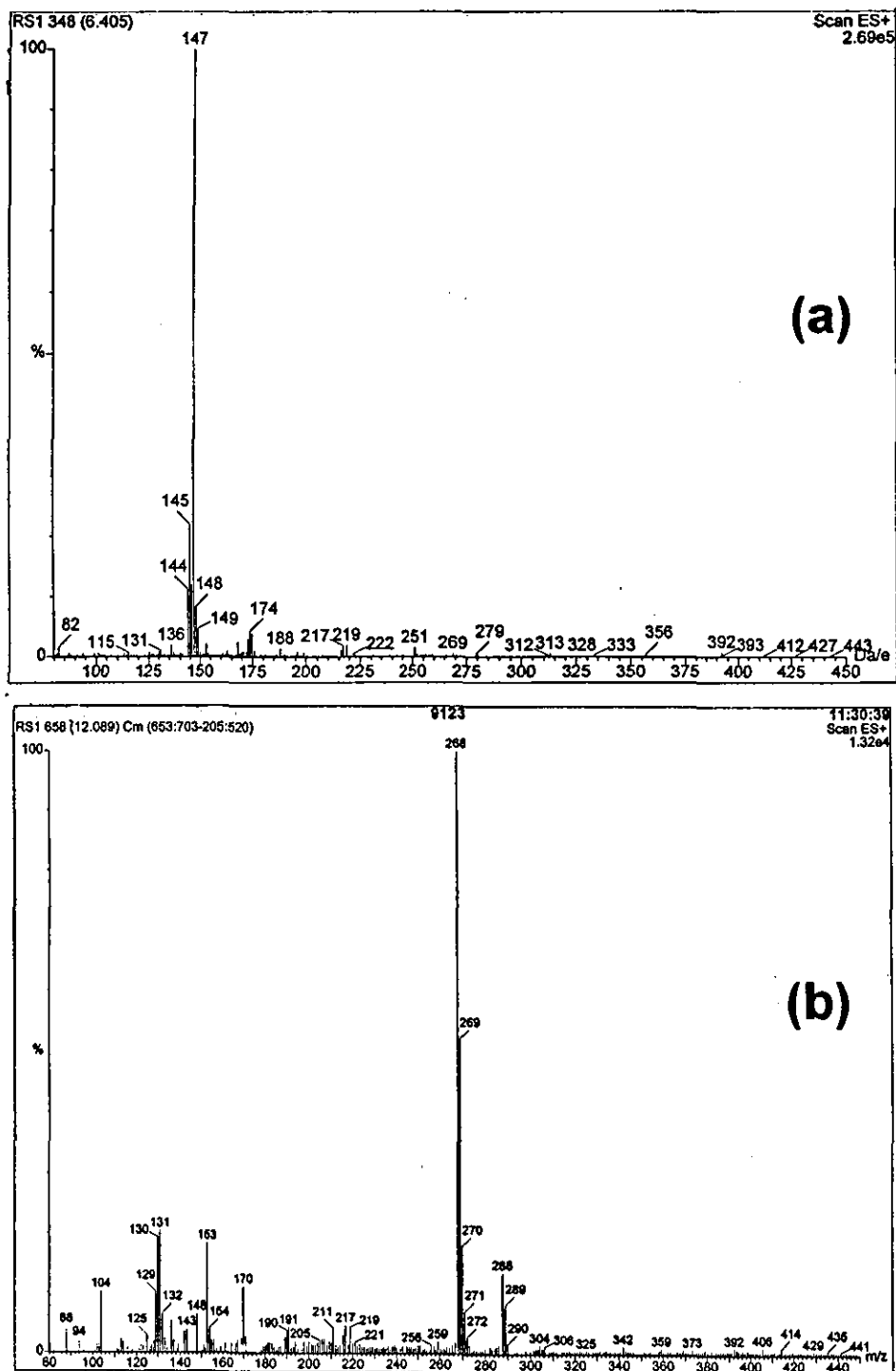


Figure 6.30 a-b MS spectra of thiamine hydrochloride separated in superheated deuterium oxide: (a) = Degraded thiazole, (b) = Thiamine

It can be concluded that thiamine was separated under buffered pH 3.0 superheated deuterium oxide, at 160 °C, resulting in the main product, deuterated thiamine, 4-methyl-5-thiazoleethanol and some unidentified products. Thiamine was deuterated at  $-\text{NH}_2$ ,  $-\text{OH}$ , and the methyl hydrogens of the pyrimidine ring and 4-methyl-5-thiazoleethanol was deuterated at  $-\text{OH}$  and at the hydrogen on thiazole ring. On raising the temperature to 190 °C, thiamine seemed to degrade more, giving a mixture of deuterated thiamine and 4-methyl-5-thiazoleethanol contained in the main peak and a small following peak containing deuterated 4-methyl-5-thiazoleethanol. When the mobile phase was changed to deuterium oxide at 190 °C, thiamine degraded even more, as the NMR spectrum no longer showed the resonances of thiamine and the MS spectrum of the main peak showed only deuterated 4-methyl-5-thiazoleethanol peak. A trace of deuterated thiamine was found in a very small amount (5%) by MS detection. The result of degradation of thiamine agreed with reports that thiamine can be degraded by heat or in basic solution at  $\text{pH} > 5.5$  [179]. Its degraded products are more than 60 components, including the main component, 4-methyl-5-thiazoleethanol [225-226]. Although, many degraded products have been characterised, only a few of them matched the degraded compounds in this work. In addition, the oxidation of thiamine to thiochrome was not found in this experiment. This was probably because thiochrome was initially present in thiamine sample at low proportion.

## 6.5 Summary

The on-line coupling of superheated water chromatography-NMR was expanded to the use of MS spectroscopy as an additional on-line detector. The detection of reactions occurring in superheated water conditions was possible, as NMR and MS provided very useful information. No problem in the use of buffer were found with ES technique, but the buffer salt ion adducts were formed, i.e.  $D^+$ ,  $Na^+$ , and  $K^+$  adduct. The great success of the hyphenated system was shown by the separation and identification of salicylamide, sulfonamides and thiamine. Two-dimensional NMR spectra was achieved using a stop-flow mode NMR for salicylamide and the resonances of the compound matched the reference spectrum. A number of sulfonamide samples, namely sulfacetamide, sulfadiazine, sulfamerazine, sulfamethazine and sulfisomidine, were investigated. NMR and MS could detect deuteration of the compounds under superheated conditions, as some expected NMR resonances disappeared and the ions detected by MS showed extra mass. We found deuterations occurred at  $NH_2$  and  $-SO_2-NH-$  and methyl groups of the pyrimidine rings.

NMR and MS could also trace the reaction and degradation of thiamine under the conditions. In buffer pH 3.0 at 160 °C, thiamine was deuterated and partly degraded to 4-methyl-5-thiazoleethanol and other trace components. At higher temperature (190 °C), thiamine was further degraded and the degraded product, 4-methyl-5-thiazoleethanol, was also deuterated. The degradation increased when changing the mobile phase from pH 3.0 to normal deuterium oxide. All of the results from these experiments were owing to a successful on-line separation and detection by superheated water chromatography-NMR and MS spectroscopy.

---

---

## **Chapter 7**

---

---

# **Conclusions and Future Work**

Superheated water has been utilised successfully as a mobile phase for liquid chromatography. The application of buffers, the effects of additives to the mobile phase and the feasibility of coupling of the chromatography to a number of detection methods: UV, fluorescence, NMR and MS were demonstrated.

### **7.1 Using modifiers and buffers**

Buffered (i.e. phosphate, borate, etc.) water was shown to be attractive for the separation of ionisable compounds as it could control the pH during separation, without salt precipitation in the system. The separations were more consistent on a run to run basis and no damage was found in the hardware system. A comparison between the separation with buffered superheated water

chromatography and a conventional reversed-phase chromatography showed that the retention order of compounds was very similar. It was shown that there was little change in the pH of the buffer at elevated temperature. The dissociations of model compounds increased at elevated temperature, compared to those measured at room temperature.

Ion-pair reagents, could also be added to the mobile phase and the separations of ionised analytes followed those the conventional reversed-phase LC mode.

Most of the work was performed on PS-DVB columns because ODS columns collapsed. It was found that the superheated water caused a permanent damage to silica-based column.

## **7.2 Detection methods**

Most LC spectroscopic detectors were found to be compatible with the superheated water chromatographic system. Both UV and fluorescence detection methods were employed. However, the fluorescence of some compounds, i.e. dansyl amino acid, was quenched by heat from the system. The response for riboflavin using a fluorescence detection was linear and the sensitivity of this method was comparable to a conventional RP-HPLC.

Despite of the sensitivity difference between UV and NMR detection, the on-line linking of superheated heavy water chromatography-UV with NMR was very successful. The sensitivity of NMR was improved by using the stop flow method. Unlike SFC-NMR, the detection could be carried out at room temperature and pressure. This provides additional benefits as the spectra can be compared to

reference spectra obtained by conventional NMR measurement. Deuterium oxide proved to be a perfectly substitute for water when on-line coupled to the NMR. The NMR spectra of a series of model compounds, such as barbiturates, some analgesics, and a separated kava extract were confirmed by the reference spectra and demonstrated successful separation and simultaneous identification. By using the stop-flow mode, COSY spectrum of salicylamide could be obtained. An extension of superheated water LC-NMR to MS detection was also achieved, as we could monitor reactions occurring under superheated water conditions. Separation and on-line identification of a series of sulfonamides and thiamine were studied. The deuteration of sulfonamide compounds and a degradation and deuteration of thiamine were observed. The spectra of the separated sulfonamides showed that protons of methyl group(s) of pyrimidine ring were exchanged. A similar reaction occurred to the methyl group on pyrimidine ring of thiamine. Thiamine might be oxidised to thiochrome during separation. The NMR and MS results showed that the major degradation product was 4-methyl-5-thiazoleethanol and both compounds were further deuterated under superheated water conditions. The NMR measurement of separated riboflavin resulted in a spectrum which corresponded to those of the reference but a signal was absent. Since the separation was under superheated water conditions, we suspected those hydrogens had been exchanged with deuterium. As the time was limited, a confirmation by MS result could not be performed but should be the subject of further study. As the spectra obtained from NMR and MS were very informative for structural elucidation, this method could be applied to a study of natural products. No problem was found in using buffered superheated deuterium oxide in the hyphenated system.

## **Future work**

Although quite a number of detection methods were demonstrated in the present work, some detectors were not examined, for example refractive index (RI) detector. As the RI detector is very thermally sensitive [45], we postulated that it might not be suitable for the detection system, unless a highly efficient cooling system can be used. Other detection methods, such as infrared (IR) spectrometer, electrochemical detector, etc. may be possible. Problems that may arise when coupling to IR detector are an unavoidable strong –OH transmission band of superheated water mobile phase [45], the low sensitivity of IR detection [46], a suitable water resistant flow cell, etc. Electrochemical detector would be more suitable, however, it is necessary to have an extremely pure mobile phase with free of oxygen [46]. Other detection techniques, including flame ionisation detector (FID), thermionic detector (TID) and flame photometric detector (FPD), from gas chromatography may be of more interest. Recently, superheated water chromatography with FID has been exploited in a separation and detection of volatile and non-volatile compounds [32, 227-228].

Applications of the coupled superheated water LC-NMR-MS system to complicated or unknown compounds, such as hormone and drug identifications is a positive future role. As well as the coupling of the system to  $^1\text{H}$  NMR, coupling to  $^{19}\text{F}$  NMR may be possible, though the sensitivity of  $^{19}\text{F}$  NMR is lower. As deuteration occurred under superheated water conditions, this reaction could be employed to form deuterated compounds which might make an internal standard for mass spectroscopy.

Pawlowski *et al.* added very small amount of organic additives, such as acetonitrile to superheated water to improve the peak shape. [35]. They

revealed that by using PRLP-S column and an addition of 1% acetonitrile in superheated water could reduce the interfacial tension and promote the mass transfer but it did not change the solvation properties of water. Similar experiment will be also interesting for PBD-zirconia and other columns. However, a major problem still facing superheated water is a good thermally stable column.



## REFERENCES

- [1] Christopher M., AP Dictionary of Science and Technology, Academic Press Inc., 1996.
- [2] Franks, F., *WATER, A comprehensive Treatise*, Plenum Press, London, 1972, Vol 1, Ch. 10.
- [3] Akerlof, G. C., Oshry, H. I., The Dielectric Constant of Water Temperatures and in Equilibrium with its Vapor, *J. Am. Chem. Soc.*, 1950, **72**, 2844-2847.
- [4] Melander, W. R., Horvath, C., *High-Performance Liquid Chromatography – Advances and Perspectives*, Academic Press Inc., New York, 1980, Vol 2, p. 113.
- [5] Flick, E. W., *Industrial Solvents Handbook*, Noyes Data Corporation, New Jersey, 4<sup>th</sup> ed., p. 269.
- [6] Walsh, D., *Chemical Safety Data Sheet*, Royal Society of Chemistry, Cambridge, Vol 1, 1989.
- [7] Pump.Net - *Steam Data*, 1998. (<http://pump.net/otherdata/steam.htm>)
- [8] Savage, P. E., Organic Chemical Reactions in Supercritical Water, *Chem. Rev.*, 1999, **99**, 603-621.
- [9] Chandler, K., Deng, F., Dillow, A. K., Liotta, C. L., Eckert, C. A., Alkylation Reactions in Near-Critical Water in the Absence of Acid Catalysts, *Ind. Eng. Chem. Res.*, 1997, **36**, 5175-5179.
- [10] Xu, X., Antal, M. J., Anderson, D. G. M., Mechanism and Temperature-Dependent Kinetics of the Dehydration of Tert-Butyl Alcohol in Hot Compressed Liquid Water, *Ind. Eng. Chem. Res.*, 1997, **36**, 23-41.
- [11] Lee, J. H., Foster, N. R., Direct Partial Oxidation of Methane to Methanol in Supercritical Water, *J. Supercrit. Fluids*, 1996, **9**, 99-105.
- [12] Scientific American, *Anatomy of the Vent*, 1998. (<http://www.sciam.com/explorations/1998/070698atlantis/vent.html>)

- [13] Getting to the Bottom, *Scientific American Explorations*, 1998, June 29.
- [14] Thomson, T. B., Modell, M., Supercritical Water Destruction of Aqueous Wastes, *Hazardous Waste*, 1984, **1**, 453.
- [15] Berger, T. A., *Packed Column SFC*, The Royal Society of Chemistry, Cambridge, 1995.
- [16] Smith, R. M., *Supercritical Fluid Chromatography*, The Royal Society of Chemistry, London, 1988.
- [17] Hawthorne, S. B., Yang, Y., Miller, D. J., Extraction of Organic Pollutants from Environmental Solids with Sub- and Supercritical Water, *Anal. Chem.*, 1994, **66**, 2912-2920.
- [18] Yang, Y., Bowadt, S., Hawthorne, S. B., Miller, D. J., Subcritical Water Extraction of Polychlorinated Biphenyls from Soil and Sediment, *Anal. Chem.*, 1995, **67**, 4571-4576.
- [19] Yang, Y., Hawthorne, S. B., Miller, D. J., Class-Selective Extraction of Polar, Moderately Polar and Nonpolar Organics from Hydrocarbon Wastes Using Subcritical Water, *Environ. Sci. Technol.*, 1997, **31**, 430-437.
- [20] Johnson, M. D., Huang, W. L., Dang, Z., Weber, W. J., A Distributed Reactivity Model for Sorption by Soils and Sediments. 12. Effects of Subcritical Water Extraction and Alterations of Soil Organic Matter on Sorption Equilibria, *Environ. Sci. Technol.*, 1999, **33**, 1657-1663.
- [21] Crescenzi, C., D'Ascenzo, G., Di Corcia, A., Nazzari, M., Marchese, S., Samperi, R., Multiresidue Herbicide Analysis in Soil: Subcritical Water Extraction with an On-line Sorbent Trap, *Anal. Chem.*, 1999, **71**, 2157-2163.
- [22] Pawlowski, T. M., Poole, C. F., Extraction of Thiabendazole and Carbendazim from Foods Using Pressurized Hot (Subcritical) Water for Extraction: A Feasibility Study, *J. Agric. Food Chem.*, 1998, **46**, 3124-3132.
- [23] Yang, Y., Li, B., Subcritical Water Extraction Coupled to High-Performance Liquid Chromatography, *Anal. Chem.*, 1999, **71**, 1491-1495.
- [24] Jimenez-Carmona, M. M., Luque de Castro, M. D., An Approach for Monitoring Subcritical Water Extraction Kinetics of Fluorescent Analytes, *Anal. Chim. Acta*, 1997, **342**, 215-221.

- [25] Miller, D. J., Hawthorne, S. B., Gizir, A. M., Clifford, A. A., Solubility of Polycyclic Aromatic Hydrocarbons in Subcritical Water from 298 K to 498 K, *J. Chem. Eng. Data*, 1998, **43**, 1043-1047.
- [26] Miller, D. J., Hawthorne, S. B., Method for Determining the Solubilities of Hydrophobic Organics in Subcritical Water, *Anal. Chem.*, 1998, **70**, 1618-1621.
- [27] Yang, Y., Belghazi, M., Lagadec, A., Miller, D. J., Hawthorne, S. B., Elution of Organic Solutes from Different Polarity Sorbents Using Subcritical Water, *J. Chromatogr. A*, 1998, **810**, 149-159.
- [28] Hageman, K. J., Mazeas, L., Grabanski, C. B., Miller, D. J., Hawthorne, S. B., Coupled Subcritical Water Extraction with Solid-Phase Microextraction for Determining Semivolatile Organics in Environmental Solids, *Anal. Chem.*, 1996, **68**, 3892-3898.
- [29] Basile, A., Jimenez-Carmona, M. M., Clifford, A. A., Extraction of Rosemary by Superheated Water, *J. Agric. Food Chem.*, 1998, **46**, 5205-5209.
- [30] Smith, R. M., Burgess, R. J., Superheated Water-a Clean Eluent for Reversed-phase High-performance Liquid Chromatography, *Anal. Comm.*, 1996, **33**, 327-329.
- [31] Smith, R. M., Burgess, R. J., Superheated Water as an Eluent for Reversed-Phase High-Performance Liquid Chromatography, *J. Chromatogr. A*, 1997, **785**, 49-55.
- [32] Miller, D. J., Hawthorne, S. B., Subcritical Water Chromatography with Flame Ionization Detection, *Anal. Chem.*, 1997, **69**, 623-627.
- [33] Yang, Y., Jones, A. D., Eaton, C. D., Retention Behavior of Phenols, Anilines, and Alkylbenzenes in Liquid Chromatographic Separations Using Subcritical Water as the Mobile Phase, *Anal. Chem.*, 1999, **71**, 3808-3813.
- [34] Hu, W., Hasebe, K., Haddad, P. R., Temperature Effects on Retention in Reversed-phase Liquid Chromatography of Nucleosides and Their Bases Using Water as Mobile Phase, *Anal. Comm.*, 1997, **34**, 311-314.
- [35] Pawłowski, T. M., Poole, C. F., Solvation Characteristic of Pressurized Hot Water and Its Use in Chromatography, *Anal. Commun.*, 1999, **36**, 71-75.

- [36] Burgess, R. J., *Superheated Water as a Mobile Phase*, Ph.D. thesis, Loughborough University, Loughborough, 1999.
- [37] Liu, G., Xin, Z., Retention Study on Silica Gel in High-Temperature Liquid Chromatography (HTLC), *Chromatographia*, 1998, **47**, 278-284.
- [38] Willard, H. H., Merritt, Jr., L. L., Dean, J. A., Settle, Jr., F.A., *Instrumental Method of Analysis*, Wadsworth Publishing Co., California, 1988, pp. 14-17, 199-200.
- [39] Christian, G. D., O'Reilly, J. E., *Instrumental Analysis*, Prentice Hall Inc., New Jersey, 2<sup>nd</sup> ed., 1986, pp. 671, 856.
- [40] ASTM Subcommittee E19.07, Standard Recommended Practice for Testing Flame Ionization Detectors Used in Gas Chromatography (E594 – 77), *ASTM Standards on Chromatography*, American Society for Testing and Materials, Philadelphia, 1989, pp. 671-676.
- [41] Sadek, P. C., *The HPLC Solvent Guide*, John Wiley & Sons Inc., New York, 1996, pp. 1-6, 19-20.
- [42] Dolan, J. W., Marchand, D. H., Cahill, S. A., Air: Poison for Liquid Chromatography, *LC-GC Int.*, Advanstar Communications, 1997, **10**, 274-277.
- [43] Parriott, D., *A Practical Guide to HPLC Detection*, Academic Press Inc., California, 1993, pp. 39-40, 50, 53, 56-64, 118-119, 190-193.
- [44] Clark, B. J., Frost, T., Russell, M. A., *UV Spectroscopy Techniques, instrumentation, data monitoring*, Chapman & Hall Ltd., London, 1993, p. 23.
- [45] Vickrey, T. M., *Liquid Chromatography Detectors*, Marcel Dekker, Inc., New York and Basel, 1983, pp. 32-33, 165-204, 249-250, 323-329.
- [46] Scott, R. P. W., *Liquid Chromatography Detectors*, Elsevier Science Publishers B. V., Amsterdam, 2<sup>nd</sup> ed., 1986, pp. 94-95, 182-183, 210-215, 235.
- [47] Lee, M. L., and Markides, K. E., *Analytical Supercritical Fluid Chromatography and Extraction*, Chromatography Conferences, Inc., Utah, 1990, pp. 173, 207, 267.
- [48] Albert, K., Supercritical Fluid Chromatography-Proton Nuclear Magnetic Resonance Spectroscopy Coupling, *J. Chromatogr. A*, 1997, **785**, 65-83.

- [49] Christian, G.D., and O'Reilly, J.E., *Instrumental Analysis*, Allyn and Bacon, Inc., London, 1986, 2<sup>nd</sup> ed.
- [50] Haugland, R. P., *Handbook of Fluorescent Probes and Research Chemicals*, Molecular Probes Inc., Eugene, 6<sup>th</sup> ed., 1996.
- [51] Molecular Probes Inc., *Molecular Probes Literature*, 1996-1999. ([www.probes.com/lit/](http://www.probes.com/lit/))
- [52] Miller, J. N., *Standards in Fluorescence Spectrometry*, Chapman & Hall Ltd., 1981, pp. 6, 44-46.
- [53] Guilbault, G. G., *Fluorescence: Theory, Instrument and Practice*, Marcel Dekker, New York, 1967, pp. 76-86, 91-95, 99-114, 117-123.
- [54] Rendell, D., *Fluorescence and Phosphorescence*, John Wiley & Sons Inc., Chichester, UK, 1987.
- [55] Yeung, E.S., *Detectors for Liquid Chromatography, Volume 89*, John Wiley & Sons Inc., Chichester, 1986.
- [56] Haug, M., Schulpin, H., -J., Determination of the Fluorescence Lifetime and Oxygen Quenching Rate of Vapor-Phase Fluoranthene at High Oxygen Pressures, *Appl. Spectrosc.*, 1994, **48**, 969-972.
- [57] White, C. E., Argauer, R. J., *Fluorescence Analysis, a Practical Approach*, Marcel Dekker Inc., 1970, p. 181.
- [58] Homma, Y., Murase, Y., Sonehara, K., The Effect of Temperature on Fluorescence for Liquid Scintillators and Their Solvents, *Appl. Radiat. Isot.*, 1987, **38**, 91-96.
- [59] Fjeldstead, J. C., Lee, M. L., Capillary Supercritical Fluid Chromatography, *Anal. Chem.*, 1984, **56**, 619A-628A.
- [60] Fjeldsted, J. C., Richter, B. E., Jackson, W. P., and Lee, M. L., Scanning Fluorescence Detection in Capillary Supercritical Fluid Chromatography, *J. Chromatogr.*, 1983, **279**, 423-430.
- [61] Peaden, P. A., Fjeldsted, J. C., Lee, M. L., Springston, S. R., Novotny, M., Instrumental Aspects of Capillary Supercritical Fluid Chromatography, *Anal. Chem.*, 1982, **54**, 1090-1093.
- [62] Sandmann, B. W., Grayeski, M. L., Evaluation of a Detector Interface for Supercritical Fluid Chromatography Using Low-Pressure Flow Cells, *J. Chromatogr. Sci.*, 1993, **31**, 49-54.

- [63] Sandmann, B. W., Grayeski, M. L., Peroxalate Chemiluminescence Detection with Packed Column Supercritical Fluid Chromatography, *Chromatographia*, 1994, **38**, 163-167.
- [64] Smith, R. M., Chienthavorn, O., Danks, N., Wilson, I. D., Fluorescence Detection in Packed-Column Supercritical Fluid Chromatographic Separations, *J. Chromatogr. A*, 1998, **798**, 203-206.
- [65] Parker, S. P., *McGraw-Hill Dictionary of Chemistry*, McGraw-Hill Co. Inc., 1997, 454.
- [66] Akitt, J. W., *NMR and Chemistry*, Chapman & Hall Ltd, London, 1992, 3<sup>rd</sup> ed., p. 36.
- [67] Watanabe, N., Niki, E., *Proc. Jpn. Acad., Ser.B*, 1978, **54**, 194-199 (abstract).
- [68] Bayer, E., Albert, K., Nieder, M., Grom, E., Keller, T., On-Line Coupling of High-Performance Liquid Chromatography and Nuclear Magnetic Resonance, *J. Chromatogr.*, 1979, **186**, 497-507.
- [69] Albert, K., On-line Use of NMR Detection in Separation Chemistry, *J. Chromatogr. A*, 1995, **703**, 123-147.
- [70] Lindon, J. C., Farrant, R. D., Sanderson, P. N., Doyle, P. M., Gough, S. L., Spraul, M., Hofmann, M., Nicholson, J. K., Separation and Characterization of Components of Peptide Libraries Using On-Flow Coupled HPLC-NMR Spectroscopy, *Magn. Reson. Chem.*, 1995, **33**, 857-863.
- [71] Lenz, E. M., Greatbanks, D., Wilson, I. D., Spraul, M., Hofmann, M., Troke, J., Lindon, J. C., Nicholson, J. K., Direct Characterization of Drug Glucuronide Isomers in Human Urine by HPLC-NMR Spectroscopy: Application to the Positional Isomers of 6,11- Dihydro-11-Oxodibenz[b,e]oxepin-2-Acetic Acid Glucuronide, *Anal. Chem.*, 1996, **68**, 2832-2837.
- [72] Scarfe, G. B., Wright, B., Clayton, E., Taylor, S., Wilson, I. D., Lindon, J. C., Nicholson, J. K., <sup>19</sup>F-NMR and Directly Coupled HPLC-NMR-MS Investigations into the Metabolism of 2-Bromo-4-Trifluoromethylaniline in Rat: a Urinary Excretion Balance Study without the Use of Radiolabelling, *Xenobiotica*, 1998, **28**, 373-388.

- [73] Clayton, E., Taylor, S., Wright, B., Wilson, I. D., The Application of High Performance Liquid Chromatography Coupled to Nuclear Magnetic Resonance Spectroscopy and Mass Spectrometry (HPLC-NMR-MS), to the Characterisation of Ibuprofen Metabolites from Human Urine, *Chromatographia*, 1998, **47**, 264-270.
- [74] Wilson, I. D., Morgan, E. D., Lafont, R., Wright, B., High-Performance Liquid Chromatography Coupled to Nuclear Magnetic Resonance Spectroscopy Application to the Ecdysteroids of *Silene otites*, *J. Chromatogr. A*, 1998, **799**, 333-336.
- [75] Godejohann, M., Preiss, A., Mugge, C., Wunsch, G., Application of On-Line HPLC-<sup>1</sup>H NMR to Environmental Samples: Analysis of Groundwater near Former Ammunition Plants, *Anal. Chem.*, 1997, **69**, 3832-3837.
- [76] Friebolin, H., *Basic One- and Two-Dimensional NMR Spectroscopy*, VCH Publishers, New York, 1993, 2<sup>nd</sup> ed., pp.130, 145, 171.
- [77] Spraul, M., Hofmann, M., Dvortsak, P., Nicholson, J. K., Wilson, I. D., High-Performance Liquid Chromatography Coupled to High-Field Proton Nuclear Magnetic Resonance Spectroscopy: Application to the Urinary Metabolites of Ibuprofen, *Anal. Chem.*, 1993, **65**, 327-330.
- [78] Braumann, U., Handel, H., Strohschein, S., Spraul, M., Krack, G., Ecker, R., Albert, K., Separation and Identification of Vitamin A Acetate Isomers by Supercritical Fluid Chromatography-<sup>1</sup>H NMR Coupling, *J. Chromatogr. A*, 1997, **761**, 336-340.
- [79] Oki, M., *Applications of Dynamic NMR Spectroscopy to Organic Chemistry*, VCH Publishers, Inc., 1985, p. 34.
- [80] Williams, D. H., Fleming, I., *Spectroscopic Methods in Organic Chemistry*, McGraw-Hill, Ltd., London, 1987, 4<sup>th</sup> ed., p. 75.
- [81] Martin, M. L., Delpuech, J.-J., Martin, G. J., *Practical NMR Spectroscopy*, Heyden & Sons Ltd., 1980, p. 266.
- [82] Albert, K., Braumann, U., Tseng, L. H., Nicholson, G., Bayer, E., Spraul, M., Hofmann, M., Dowle, C., Chippendale, M., On-Line Coupling of Supercritical Fluid Chromatography and Proton High-Field Nuclear Magnetic Resonance Spectroscopy, *Anal. Chem.*, 1994, **66**, 3042-3046.

- [83] Allen, L. A., Glass, T. E., Dorn, H. C., Direct Monitoring of Supercritical Fluids and Supercritical Chromatographic Separations by Proton Nuclear Magnetic Resonance, *Anal. Chem.*, 1988, **60**, 390-394.
- [84] Jonas, J., Nuclear Magnetic Resonance at High Pressure, *Science*, 1982, **216**, 1179-1184.
- [85] Yoshida, K., Ibuki, K., Ueno, M., Pressure and Temperature Effects on H-2 Spin-Lattice Relaxation Times and H-1 Chemical Shifts in Tert-Butyl Alcohol- and Urea-D<sub>2</sub>O Solutions, *J. Chem. Phys.*, 1998, **108**, 1360-1367.
- [86] Gunther, H., *NMR Spectroscopy: Basic Principles, Concepts, and Applications in Chemistry*, John Wiley & Sons Inc., Chichester, England, 1992, pp. 63-64.
- [87] Wu, N., Peck, T. L., Webb, A. G., Magin, R. L., Sweedler, J. V., H-1-NMR Spectroscopy on the Nanoliter Scale for Static and Online Measurements, *Anal. Chem.*, 1994, **66**, 3849-3857.
- [88] Godejohann, M., Preiss, A., Quantitative Measurements in Continuous Flow HPLC / NMR, *Anal. Chem.*, 1998, **70**, 590-595.
- [89] Gfroerer, P., Schewitz, J., Pusecker, K., Bayer, E., On-Line Coupling of Capillary Separation Techniques with <sup>1</sup>H NMR, *Anal. Chem. News & Features*, 1999, **May 1**, 315A-321A.
- [90] Pusecker, K., Schewitz, J., Gfroerer, P., Tseng, L. H., Albert, K., Bayer, E., On-Line Coupling of Capillary Electrochromatography, Capillary Electrophoresis, and Capillary HPLC with Nuclear Magnetic Resonance Spectroscopy, *Anal. Chem.*, 1998, **70**, 3280-3285.
- [91] Albert, K., Dachtler, M., Glaser, T., Handel, H., Lacker, T., Schlotterbeck, G., Strohschein, S., Tseng, L.-H., On-Line Coupling of Separation Techniques to NMR, *J. High Resol. Chromatogr.*, 1999, **22**, 135-143.
- [92] Niessen, W. M. A., van der Greef, J., *Liquid Chromatography-Mass Spectrometry*, Marcel Dekker Inc., 1992.
- [93] Kitson, F. G., Larson, B. S., McEwen, C. N., *Gas Chromatography and Mass Spectrometry: a practical guide*, Academic Press, London, 1996.
- [94] Chapman, J. R., *Practical Organic Mass Spectrometry*, John Wiley & Sons Inc., New York, 1985, 56.



- [95] Niessen, W. M. A., Tjaden, U. R., Van Der Greef, J., Strategies in Developing Interfaces for Coupling Liquid Chromatography and Mass Spectrometry, *J. Chromatogr.*, 1991, **554**, 3-26.
- [96] Niessen, W. M. A., Tinkle, A. P., Liquid Chromatography-Mass Spectrometry General Principles and Instrumentation, *J. Chromatogr. A*, 1995, **703**, 37-57.
- [97] Parriott, D., *A Practical Guide to HPLC Detection*, Academic Press, Inc., California, 1993, pp. 39-40, 50, 53, 56-64, 177, 190-193.
- [98] Pinkston, J. D., Owens, G. D., Burkes, L. J., Delaney, T. E., Millington, D. S., and Maltby, D. A., Capillary Supercritical Fluid Chromatography-Mass Spectrometry Using a High Mass Quadrupole and Splitless Injection, *Anal. Chem.*, 1988, **60**, 962-966.
- [99] Hawthorne, S. B., and Miller, D. J., Supercritical-Fluid Chromatography-Mass Spectrometry of Polycyclic Aromatic-Hydrocarbons with a Simple Capillary Direct Interface, *J. Chromatogr.*, 1989, **468**, 115-125.
- [100] Holzer, G., Deluca, S., Voorhees, K. J., Capillary Supercritical Fluid Chromatography with Simultaneous Flame Ionization and Mass-Spectrometric Detection, *J. High Resolut. Chromatogr., Chromatogr. Commun.*, 1985, **8**, 528-531.
- [101] Smith, R. D., Fulton, J. L., Peterson, R. C., Kopriva, A. J., and Wright, B. W., Performance of Capillary Restrictors in Supercritical Fluid Chromatography, *Anal. Chem.*, 1986, **58**, 2057-2064.
- [102] Cousin, J., Arpino, P. J., Construction of a Supercritical Fluid Chromatograph Mass-Spectrometer Instrument System Using Capillary Columns, and a Chemical Ionization Source Accepting High Flow-Rates of Mobile Phase, *J. Chromatogr.*, 1987, **398**, 125-141.
- [103] Dole, M., Mack, L. L., Hines, R. L., Mobley, R. C., Ferguson, L. D., Alice, M. B., Molecular Beams of Macroions, *J. Chem. Phys.*, 1968, **49**, 2240-2249.
- [104] Whitehouse, C. M., Dreyer, R. N., Yamashita, M., Fenn, J. B., Electrospray Interface for Liquid Chromatographs and Mass Spectrometer, *Anal. Chem.*, 1985, **57**, 675-679.
- [105] Fenn, J. B., Mann, M., Meng, C. K., Wong, S. F., Whitehouse, C. M.,

- Electrospray Ionization for Mass Spectrometry of Large Biomolecules, *Science*, 1989, **246**, 64-71.
- [106] Kebarle, P., Tang, L., From Ions in Solution to Ions in the Gas Phase, *Anal. Chem.*, 1993, **65**, 972A-986A.
- [107] Bruins, A. P., Covey, T. R., Henion, J. D., Ion Spray Interface for Combined Liquid Chromatography/Atmospheric Pressure Ionization Mass-Spectrometry, *Anal. Chem.*, 1987, **59**, 2642-2646.
- [108] Chowdhury, S. K., Katta, V., Chait, B. T., An Electrospray-Ionization Mass-Spectrometer with New Features, *Rapid Commun. Mass Spectrom.*, 1990, **4**, 81-87.
- [109] Allen, M. H., Vestal, M. L., Design and Performance of a Novel Electrospray Interface, *J. Am. Soc. Mass Spectrom.*, 1992, **3**, 18-26.
- [110] Sakairi, M., Kato, Y., Multi-Atmospheric Pressure Ionisation Interface for Liquid Chromatography Mass Spectrometry, *J. Chromatogr.*, 1998, **794**, 391-406.
- [111] Imatani, K., Smith, C., An Easy-To-Use Benchtop Liquid Chromatograph Mass Selective Detector, *Am. Lab.*, 1996, **28**, 29.
- [112] Niessen, W. M. A., Advances in Instrumentation in Liquid Chromatography-Mass Spectrometry and Related Liquid-Introduction Techniques, *J. Chromatogr. A*, 1998, **794**, 407-435.
- [113] Hearn, M. T. W., *Ion-pair chromatography*, Marcel Dekker Inc., New York, 1985.
- [114] Pietrzyk, D. J., Kroeff, E. P., Rotsch, T. D., Effect of Solute Ionization on Chromatographic Retention on Porous Polystyrene Copolymers, *Anal. Chem.*, 1978, **50**, 497-502.
- [115] Personal communication from S. Saha.
- [116] Gilman, A. G., Rall, T. W., Nies, A. S., Taylor, P., *Goodman and Gilman's The Pharmacological Basis of Therapeutics*, Pergamon Press, New York, 8<sup>th</sup> ed., 1990, pp. 363, 656, 1047.
- [117] Tarbin, J. A., Clarke, P., Shearer, G., Screening of Sulphonamides in Egg Using Gas Chromatography-Mass-Selective Detection and Liquid Chromatography-Mass Spectrometry, *J. Chromatogr. B*, 1999, **729**, 127-138.

- [118] Chiavarino, B., Crestoni, M. E., DiMarzio, A., Fornarini, S., Determination of Sulfonamide Antibiotics by Gas Chromatography Coupled with Atomic Emission Detection, *J. Chromatogr. B*, 1998, **706**, 269-277.
- [119] Mooser, A. E., Koch, H., Confirmatory Method For Sulfonamide Residues In Animal-Tissues By Gas-Chromatography And Pulsed Positive Ion-Negative Ion-Chemical Ionization Mass-Spectrometry, *J. AOAC Int.*, 1993, **76**, 976-982.
- [120] Tomankova, H., Vasatova, M., Zyka, J., A TLC-Densitometric Determination of Sulfonamide Chemotherapeutics, *Anal. Lett.*, 1988, **21**(12), 2227-2240.
- [121] Unruh, J., Schwartz, D. P., Barford, R. A., Quantitation of Sulfamethazine in Pork Tissue by Thin-Layer Chromatography, *J. AOAC Int.*, 1993, **76**, 335-341.
- [122] Lin, C. L., Hong, C. C., Kondo, F., Simultaneous Determination of Residual Sulphonamides in the Presence and Absence of p-Aminobenzoic Acid by High-Performance Liquid Chromatography, *Microbios*, 1995, **83**, 175-183.
- [123] AshrafKhorassani, M., Combs, M. T., Taylor, L. T., Willis, J., Liu, X. J., Frey, C. R., Separation and Identification of Sulfonamide Drugs via SFC/FT-IR Mobile-Phase Elimination Interface, *Appl. Spectrosc.*, 1997, **51**, 1791-1795.
- [124] Perkins, J. R., Games, D. E., Startin, J. R., Gilbert, J., Analysis of Sulfonamides Using Supercritical Fluid Chromatography and Supercritical Fluid Chromatography Mass-Spectrometry, *J. Chromatogr.*, 1991, **540**, 239-256.
- [125] Cobb, P. H., Hill, G. T., High-performance liquid chromatography of some sulfonamides, *J. Chromatogr.*, 1976, **123**, 444-447,
- [126] Cross, R. F., Narrow-bore High Performance Liquid Chromatography Separations of 22 Sulfonamides, *J. Chromatogr.*, 1989, **478**, 422-428.
- [127] Roos, R. W., High Pressure Liquid Chromatographic Determination of Sulfisoxazole in Pharmaceuticals and Separation Patterns of Other Sulfonamides, *J. AOAC.*, 1981, **64**, 851-854.
- [128] Ricci, M., Cross, R. F., High Performance Liquid Chromatographic Analysis of Sulphonamides and Dihydrofolate Reductase Inhibitors. I.

- Separations in Methanol-Modified Solutions, *J. Liquid Chromatogr. Relat. Technol.*, 1996, **19**, 365-381.
- [129] Ricci, M., Cross, R. F., High Performance Liquid Chromatographic Analysis of Sulphonamides and Dihydrofolate Reductase Inhibitors. II. Separations in Acetonitrile-Modified Solutions, Ternary Gradient Studies & Flow Programming, *J. Liquid Chromatogr. Relat. Technol.*, 1996, **19**, 547-564.
- [130] Botsoglou, N. A., Fletouris, D. J., Simeonidou, E. J., Psomas, I. E., Retention Behavior of Multiple Sulfonamides in Various Liquid Chromatographic System, *Chromatographia*, 1997, **46**, 477-482.
- [131] Jen, J. F., Lee, H. L., Lee, B. N., Simultaneous Determination of Seven Sulfonamide Residue in Swine Wastewater by High-Performance Liquid Chromatography, *J. Chromatogr. A*, 1998, **793**, 378-382.
- [132] Rotsch, T. D., Sydor, R. J., Pietrzyk, D. J., High Performance Liquid Chromatographic Study of the Retention and Sorption of Sulfas on Porous Copolymers, *J. Chromatogr. Sci.*, 1979, **17**, 339-344.
- [133] Lee, D. P., Reversed-Phase HPLC from pH 1 to 13, *J. Chromatogr. A*, 1982, **20**, 203-208.
- [134] Bugge, C. J. L., Guatam, S. R., Parke, L. E., Mason, J. T., Garcia, D. B., *J. Pharm. Sci.*, 1990, **79**, 1095.
- [135] Lin, C. E., Chang, C. C., Lin, W. C., Migration behavior and separation of sulfonamides in capillary zone electrophoresis II. Positively charged species at low pH, *J. Chromatogr. A*, 1997, **759**, 203-209.
- [136] Lin, C. E., Chang, C. C., Lin, W. C., Migration behavior and separation of sulfonamides in electrophoresis III. Citrate buffer as a background electrolyte, *J. Chromatogr. A*, 1997, **768**, 105-112.
- [137] Cross, R. F., Cao, J., Salt Effect in Capillary Zone Electrophoresis III. Systematic and Selective Factors in the High Ionic Strength Separation of Sulfonamides in Sodium Phosphate Buffers, *J. Chromatogr.*, 1998, **818**, 217-229.
- [138] Lin, C. E., Lin, W. C., Chen, Y. C., Wang, S. W., Migration behavior and selectivity of sulfonamides in capillary electrophoresis, *J. Chromatogr. A*, 1997, **792**, 37-47.

- [139] Marshall, W. L., Hall, C. E., Mesmer, R. E., The System Dipotassium Hydrogen Phosphate-Water at High Temperatures (100-400 C); Liquid-Liquid Immiscible and Concentrated Solutions., *J. Inorg. Nucl. Chem.*, 1981, **43**, 449-455.
- [140] Wofford, W. T., Gloyna, E. F., Johnston, K. P., Boric Acid Equilibria in Near-Critical and Supercritical Water, *Ind. Eng. Chem. Res.*, 1998, **37**, 2045-2051.
- [141] Xiang, T., Johnson, K. P., Wofford, W. T., Gloyna, E. F., Spectroscopic Measurement of pH in Aqueous Sulfuric Acid and Ammonia from Sub- to Supercritical Conditions, *Ind. Eng. Chem. Res.*, 1996, **35**, 4788-4795.
- [142] Perrin, D. D., Dempsey, B., *Buffers for pH and Metal Ion Control*, Chapman and Hall Ltd., London, 1974, pp. 56-57, 157-163.
- [143] Marshall, W. L., Franck, E. U., Ion Product of Water Substance, 0-1000 °C, 1-10,000 Bars New International Formulation and Its Background, *J. Phys. Chem. Ref. Data*, 1981, **10**, 295-304.
- [144] Kryukov, P. A., Perkovets, V. D., *et al.*, Standardization of pH values of Buffer, *Izv. Sib. Otd. Akad. Nauk. Sssr, Ser. Khim. Nauk*, 1966, **2**, 29-34 (Russian).
- [145] Albert, A., Serjeant, E. P., *Ionization Constants of Acids and Bases*, Butler & Tanner Ltd., London, 1962, p. 14.
- [146] Perrin, D. D., *Dissociation Constants of Organic Bases in Aqueous Solution*, Butterworth & Co. (Publishers) Ltd., London, p. 367.
- [147] Atkins, P. W., *Physical Chemistry*, Oxford University Press, Oxford, 6<sup>th</sup> ed., 1998, p. 224.
- [148] Hearn, M. T. W., *Ion-Pair Chromatography*, Marcel Dekker, Inc., New York, 1985.
- [149] Brown, P. R., *HPLC in Nucleic Acid Research*, Marcel Dekker, Inc., New York, 1984, pp. 162-174.
- [150] Argekar, A. P., Shah, S. J., Simultaneous Determination of Cinnarizine and Domepiridone Maleate from Tablet Dosage Form by Reverse Phase Ion Pair High Performance Liquid Chromatography, *J. Pharm. Biomed. Anal.*, 1999, **19**, 813-817.

- [151] Kaniou, I., Tsoukali, H., Epivatianos, P., Sulfonamides Determination in Animal-Tissues by Ion-Pair HPLC, *Spect. Lett.*, 1993, **26**, 969-973.
- [152] Yamashita, K., Motohashi, M., Yashiki, T., Sensitive High-Performance Liquid Chromatographic Determination of Propranolol in Human Plasma With Ultraviolet Detection Using Column Switching Combined with Ion-Pair Chromatography, *J. Chromatogr.*, 1990, **527**, 196-200.
- [153] Shen, J., Wanwimolruk, S., Hung, C. T., Zoest, A. R., Quantitative Analysis of  $\beta$ -Blockers in Human Plasma by Reversed-Phase Ion-Pair High-Performance Liquid Chromatography Using a Microbore Column, *J. Liq. Chromatogr.*, 1991, **14**, 777-793.
- [154] Rustum, A. M., Measurement of ibuprofen in human whole blood by reversed-phase ion-paired high-performance liquid chromatography using a pH-stable polymeric column, *J. Chromatogr.*, 1990, **526**, 246-253.
- [155] Adell, A., Tusell, J. M., Artigas, F., Martinez, E., Sunol, C., Gelpi, E., Fluorometric-Determination of Tryptophan and Its Brain Indoleamine Metabolites by Ion-Pair HPLC, *J. Liq. Chromatogr.*, 1983, **6**, 527-541.
- [156] McKeown, A. P., Barrett, D. A., Shaw, P. N., Investigating the Retention Behaviour of Oligonucleotides by Reversed-Phase Ion-Pair HPLC, *Abstr. Pap. Am. Chem. Soc.*, 1998, **216**, 68.
- [157] Kato, A., Moriyasu, M., Ichimaru, M., Nishiyama, Y., Juma, F. D., Nganga, J. N., Mathenge, S. G., Ogeto, J. O., Isolation of Alkaloidal Constituents of *Zanthoxylum Usambarense* and *Zanthoxylum Chalybeum* Using Ion-Pair HPLC, *J. Nat. Prod.*, 1996, **59**, 316-318.
- [158] Henderson, S. K., Henderson, D. E., Reversed-Phase Ion-Pair HPLC Analysis of Sugar Phosphates, *J. Chromatogr. Sci.*, 1986, **24**, 198-203.
- [159] Ivanovic, D., Popovic, A., Radulovic, D., Medenica, M., Reversed-Phase Ion-Pair HPLC Determination of Some Water-Soluble Vitamins in Pharmaceuticals, *J. Pharm. Biomed. Anal.*, 1999, **18**, 999-1004.
- [160] Tapuhi, Y., Schmidt, D. E., Lindner, W., Karger, B. L., Dansylation of Amino Acids for High-Performance Liquid Chromatography Analysis, *Anal. Biochem.*, 1981, **115**, 123-129.
- [161] Grego, B., Hearn, M. T. W., High-Performance Liquid Chromatography of Amino Acids Peptides and Proteins XXXIX. Reversed-Phase High-

- Performance Liquid Chromatographic Analysis of Dns-Amino Acids: Comparison of Several Different Elution Systems, *J. Chromatogr.*, 1983, **255**, 67-77.
- [162] Shamsi, S. A., Danielson, N. D., Warner, I. M., Flavin Mononucleotide for Indirect Laser-Induced Fluorescence Detection of Anions Separated by Capillary Electrophoresis, *J. Chromatogr. A*, 1999, **835**, 159-168.
- [163] Couderc, F., Causse, E., Bayle, C., Drug Analysis by Capillary Electrophoresis and Laser-Induced Fluorescence, *Electrophoresis*, 1998, **19**, 2777-2790.
- [164] Timperman, A. T., Sweedler, J. V., Capillary Electrophoresis with Wavelength-Resolved Fluorescence Detection, *Analyst*, 1996, **121**, R45-R52.
- [165] Heegaard, N. H. H., Nilsson, S., Guzman, N. A., Affinity Capillary Electrophoresis: Important Application Areas and Some Recent Developments, *J. Chromatogr. B*, 1998, **715**, 29-54.
- [166] Rebscher, H., Pyell, U., In-Column versus On-Column Fluorescence Detection in Capillary Electrochromatography, *J. Chromatogr. A*, 1996, **737**, 171-180.
- [167] Dadoo, R., Zare, R. N., Yan, C., Anex, D. S., Advances in Capillary Electrochromatography: Rapid and High-Efficiency Separations of PAHs, *Anal. Chem.*, 1998, **70**, 4787-4792.
- [168] Bender, G. T., *Principles of Chemical Instrumentation*, W. B. Saunders Co., London, 1987, pp. 81-93.
- [169] Combs, G F., Jr., *The Vitamins, Fundamental Aspects in Nutrition and Health*, Academic Press Inc., London, 1992, p. 277.
- [170] Verderame, M., *CRC Handbook of Hormones, Vitamins and Radiopaques*, CRC Press, Inc., Florida, 1986, p. 248.
- [171] Budavari, S., *The Merck Index*, Merck & Co. Inc., New Jersey, 12<sup>th</sup> ed., 1996.
- [172] Valls, F., Sancho, M. T., FernandezMuino, M. A., Checa, M. A., Determination Of Total Riboflavin In Cooked Sausages, *J. Agric. Food Chem.*, 1999, **47**, 1067-1070

- [173] Johansen, K., Edlund, P. O., Determination of Water-Soluble Vitamins in Blood and Plasma by Coupled-Column Liquid Chromatography, *J. Chromatogr.*, 1990, **506**, 471-479.
- [174] AndresLacueva, C., Mattivi, F., Tonon, D., Determination of Riboflavin, Flavin Mononucleotide and Flavin-Adenine Dinucleotide in Wine and Other Beverages by High-Performance Liquid Chromatography with Fluorescence Detection, *J. Chromatogr. A*, 1998, **823**, 355-363.
- [175] Papadoyannis, I. N., Tsioni, G. K., Samanidou, V. F., Simultaneous Determination of Nine Water and Fat Soluble Vitamins after SPE Separation and RP-HPLC Analysis in Pharmaceutical Preparations and Biological Fluids, *J. Liq. Chromatogr. Relat. Technol.*, 1997, **20**, 3203-3231.
- [176] King, B., Switaiski, L., Ribble-Garlick, E., Henry, R. A., BetaBasic and Aquasil HPLC Columns for the Analysis of Water-soluble Vitamins, *UK Lab.*, June 1998, 16.
- [177] *CRC Handbook of Chemistry and Physics*, The Chemical Rubber Co., Cleveland, OH, 48<sup>th</sup> ed., 1967-68.
- [178] Kutsky, R. J., *Handbook of Vitamins and Hormones*, Van Nostrand Reinhold Co., New York, 1973, pp. 39-40, 55.
- [179] Connors, K. A., Amidon, G. L., Stella, V. J., *Chemical Stability of Pharmaceuticals: A Handbook for Pharmacists*, John Wiley & Sons, New York, 1986, pp. 764-765.
- [180] Robinson, F. A., *The Vitamin Co-factors of Enzyme Systems*, Pergamon Press Ltd., London, 1966, pp. 38-39.
- [181] Helrich, K., *Official Methods of Analysis of the Association of Official Analytical Chemists*, Vol 2, Association of Official Analytical Chemists Inc., Arlington, VA, 1990, 15<sup>th</sup> ed., p.1050.
- [182] Kneifel, W. and Sommer, R., Determination of Thiamin in Milk and Milk Products by Means of HPLC, *Ernaehrung (Vienna)*, 1986, **10**, 459-464 (abstract).
- [183] Valls, F., Checa, M. A., FernandezMuino, M. A., Sancho, M. T., Determination of Thiamine in Cooked Sausages, *J. Agric. Food Chem.*, 1999, **47**, 170-173.



- [184] vanSchoonhoven, J., Schrijver, J., vandenBerg, H., and Haennen, G., Reliable and Sensitive High-Performance Liquid-Chromatographic Method with Fluorometric Detection for the Analysis of Vitamin-B-6 in Foods and Feeds, *J. Agric. Food Chem.*, 1994, **42**, 1475-1480.
- [185] Akerlof, G., Dielectric Constants of Some Organic Solvent-Water Mixtures at Various Temperatures, *J. Am. Chem. Soc.*, 1932, **54**, 4125-4139.
- [186] Bowman, W. C., Rand, M. J., *Textbook of Pharmacology*, Blackwell Scientific Publications, Oxford, 1980, 2<sup>nd</sup> ed., 16.18.
- [187] Goodman, L. S., and Gilman, A., *GOODMAN and GILMAN's The Pharmacological Basis of Therapeutics*, Macmillan Publishing Co., London, 1985, 7<sup>th</sup> ed., pp. 680-689, 1041-1044.
- [188] Wanwimolruk, S., Wong, S.M., Zhang, H., Coville, P.F., Simultaneous Determination of Quinine and a Major Metabolite 3- Hydroxyquinine in Biological Fluids by HPLC without Extraction, *J. Liq. Chromatogr. Relat. Technol.*, 1996, **19**, 293-305.
- [189] Franks, F., *Water, A comprehensive treatise*, Plenum Press, London, 1972, Vol 1, pp 304, 398.
- [190] Eck, H., *Phy. Z.*, 1939, **40**, 3
- [191] Reisenfeld, E. H., Chang, T. L., *Z. Physik. Chem.*, 1935, **B30**, 61.
- [192] <repeat Fluor-ref.> *CRC Handbook of Chemistry and Physics*, The Chemical Rubber Co., Cleveland, OH, 48<sup>th</sup> ed., 1967-68.
- [193] Creighton, A. J., Smith, R. W., *Aldrich, Catalogue Handbook of Fine Chemicals*, Sigma-Aldrich Co. Ltd., Dorset, UK, 1996-7.
- [193] *Catalog of Chromatography and Fluid Transfer Fittings*, Upchurch Scientific, Oak Harbour, WA, 1998, 48-49.
- [194] Parker, S. P., *McGraw-Hill Dictionary of Chemistry*, McGraw-Hill Co. Inc., 1997, 454.
- [195] Indrayanto, G., Sunarto, A., Adriani, Y., Simultaneous Assay of Phenylpropanolamine Hydrochloride, Caffeine, Paracetamol, Glycerylguaiacolate and Chlorpheniramine Maleate in Silabat(TM) Tablet Using HPLC with Diode Array Detection, *J. Pharm. Biomed. Anal.*, 1995, **13**, 1555-1559.

- [196] Yurdakul, G., Ersoy, L., Sungur, S., Comparison of HPLC and Derivative Spectrophotometric Methods for the Determination of Paracetamol and Caffeine in Tablets, *Pharmazie*, 1991, **46**, 885.
- [197] DeOrsi, D., Gagliardi, L., Bolasco, A., Tonelli, D., Simultaneous Determination of Triprolidine, Pseudoephedrine, Paracetamol and Dextromethorphan by HPLC, *Chromatographia*, 1996, **43**, 496-500.
- [198] Ivanovic, D., Medenica, M., Radulovic, D., Djugumovic, Z., Pharmaceutical Analysis of Beta-Methyldigoxin in Dosage Forms Using RP-HPLC, *Drug Dev. Ind. Pharm.*, 1995, **21**, 1789-1797.
- [199] Pouchert, C. J., Behnke, J., *The Aldrich Library of <sup>13</sup>C and <sup>1</sup>H FT NMR Spectra*, Aldrich Chemical Co., Milwaukee, USA, 1993, Vol 2-3.
- [200] Alexander, T. G., Maienthal, M., Assignment of the N-Methyl Hydrogen NMR Peaks of Caffeine, *J. Pharm. Sci.*, 1964, **53**, 962-963.
- [201] Bhacca, N. S., Johnson, L. F., Schoolery, J. N., *NMR Spectra Catalog*, Varian Associates, California, 1962.
- [202] Matthew, H., Acute Barbiturate Poisoning, Excerpta Medica Monograph, Amsterdam, 1971.
- [203] Gill, R., Moffat, A. C., Smith, R. M., Hurdley, T. G., A Collaborative Study to Investigate the Retention Reproducibility of Barbiturates in HPLC with a View to Establishing Retention Databases for Drug Identification, *J. Chromatogr. Sci.*, 1986, **24**, 153-159.
- [204] Ryan, T. W., Resolution of the Nonspecific Spectra of Barbiturates by UV-Photodiode Array Detection, *J. Liq. Chromatogr.*, 1993, **16**, 315-329.
- [205] Kuroda, N., Inoue, K., Mayahara, K., Nakashima, K., Akiyama, S., Application of 3-(1,8-Naphthalimido) Propyl-Modified Silyl Silica Gel as a Stationary Phase in High Performance Liquid Chromatography of Barbiturates and Diastereomeric Compounds, *J. Liq. Chromatogr. Rel. Technol.*, 1996, **19**, 2867-2881.
- [206] Avdovich, H. W., Neville, G. A., Applications of Proton Magnetic Resonance Spectroscopy to Pharmaceuticals II., *Can. J. Pharm. Sci.*, 1969, **4**, 51-64.
- [207] Rucker, G., Qualitative Analysis of Barbiturate Derivatives, *Arch. Pharm.*, 1966, **299**, 688-94.

- [208] Duke, J. A., *CRC Handbook of Medicinal Herbs*, CRC Press Inc., Florida, 1985, p. 381.
- [209] Lewis, W. H., Elvin-Lewis, M. P. F., *Medical Botany: Plants Affecting Man's Health*, John Wiley & Sons Inc., 1977, p. 439.
- [210] Smith, R. M., Kava Lactones in *Piper Methysticum* from Fiji, *Phytochemistry*, 1983, **22**, 1055-1056.
- [211] Shao, Y., He, K., Zheng, B., Zheng, Q., Reversed-Phase High-Performance Liquid Chromatographic Method for Quantitative Analysis of the Six Major Kavalactones in *Piper methysticum*, *J. Chromatogr. A*, 1998, **825**, 1-8.
- [212] Smith, R. M., Thakrar, H., Arowolo, T. A., Shafi, A. A., High Performance Liquid Chromatography of Kava Lactones from *Piper methysticum*, *J. Chromatogr.*, 1984, **283**, 303-308.
- [213] Williamson, G., Edmondson, D. E., *Methods in Enzymology*, 1986, **122**, 240-248.
- [214] Edwards, L. J., Salicylamide: Thermodynamic Dissociation Constant. Solubility and Quantitative Estimation by U.-V. Absorption Spectrophotometry, *Trans. Faraday Soc.*, 1953, **49**, 234-236.
- [215] Batterham, T. J., Brown, D. J., Paddon-Row, M. N., Simple Pyrimidines. Part IX. Deuterium Exchange of C-Methyl Protons, *J. Chem. Soc.*, 1967, **B**, 171-173.
- [216] Brown, D. J., Evans, R. F., Cowden, W. B., Fenn, M. D., *The Pyrimidines*, John Wiley & Sons Inc., Chichester, 1994, pp. 264-265.
- [217] Junk, T., Catallo, W. J., Preparative Supercritical Deuterium Exchange in Arenes and Heteroarenes, *Tetrahedron Lett.*, 1996, **37**, 3445-3448.
- [218] Junk, T., Catallo, W. J., Hydrogen Isotope Exchange Reactions Involving C-H (D, T) Bonds, *Chem. Soc. Reviews*, 1997, **26**, 401-406.
- [219] Yao, J., Evilia, R. F., Deuteration of Extremely Weak Organic Acids by Enhanced Acid-Base Reactivity in Supercritical Deuterioxide Solution, *J. Am. Chem. Soc.*, 1994, **116**, 11229-11233.
- [220] Ames, J. M., Hincelin, O., Apriyantono, A., Novel Volatile Thermal Degradation Products of Thiamine, *J. Sci. Food Agric.*, 1992, **58**, 287-289.
- [221] Guntert, M., Bruning, J., Emberger, R., Kopsel, M., Kuhn, W., Thielmann, T., Werkhoff, P., Identification and Formation of Some Selected Sulfur-

- Containing Flavor Compounds in Various Meat Model Systems, *J. Agric. Food Chem.*, 1990, **38**, 2027-2041.
- [222] Ebel, S., Herboth, M., Werner-Busse, A., Analysis of Degradation Products of Thiamine (Vitamin B1) by Means of Chromatography, *Fresenius Z. Anal. Chem.*, 1985, **320**, 724-725.
- [223] Hesse, M, Bild, N., Schmid, H., *Helv. Chim. Acta*, 1967, **50**, 808-813, (German).
- [224] Pouchert, C.J., Behnke, J., *The Aldrich Library of NMR Spectra*, Aldrich Chemical Co., Milwaukee, USA, 1974, p. 47.
- [225] Ames, J. M., Hincelin, O., Apriyantono, A., Novel Volatile Thermal Degradation Products of Thiamine, *J. Sci. Food Agric.*, 1992, **58**, 287-289.
- [226] Guntert, M., Bruning, J., Emberger, R., Kopsel, M., Kuhn, W., Thielmann, T., Werkhoff, P., Identification and Formation of Some Selected Sulfur-Containing Flavor Compounds in Various Meat Model Systems, *J. Agric. Food Chem.*, 1990, **38**, 2027-2041.
- [227] Ingelse, B. A., Janssen, H. G., Cramers, C. A., HPLC-FID with Superheated Water as the Fluent: Improved Methods and Instrumentation, *J. High Resol. Chromatorgr.*, 1998, **21**, 613-616
- [228] Smith, R. M., Burgess, R. J., Chienthavorn, O., Bone, J. R., Superheated Water: A New Look at Chromatographic Eluents for Reversed-Phase HPLC, *LC-GC North America*, 1999, **17**, 938-945.

## PAPERS AND PRESENTATIONS

### **Papers:**

- Smith, R. M., Chienthavorn, O., Wilson, I. D., Wright, B., Superheated Deuterium Oxide Reversed-Phase Chromatography Coupled to Proton Nuclear Magnetic Resonance Spectroscopy, *Anal. Commun.*, 1998, **35**, 261-263.
- Smith, R. M., Burgess, R. J., Chienthavorn, O., Stuttard, J. R., Superheated Water; A New Look at Chromatographic Eluents for Reversed-Phase Liquid Chromatography, *LC-GC Int.*, 1999, **12**, 30-35.
- Chienthavorn, O. and Smith, R. M., Buffered Superheated Water as an Eluent for Reversed-Phase High Performance Liquid Chromatography, *Chromatographia*, 1999, **50**, 485-490.
- Smith, R. M., Chienthavorn, O., Wilson, I. D., Wright, B., Taylor, S. D., Superheated Heavy Water as the Eluent for HPLC-NMR and HPLC-NMR-MS of Model Drugs, *Anal. Chem.*, 1999, **71**, 4993-4997.
- Smith, R. M., Chienthavorn, O., Wilson, I. D., Wright, B., Taylor, S. D., Selective Deuterium Exchange during Superheated Heavy Water Chromatography-NMR-MS of Sulfonamides, (in preparation).

### **Presentations:**

- Smith, R. M., Chienthavorn, O., Danks, N., "Fluorescence Detection in SFC Separations", presented at HPLC'97, 21st International Symposium on High Performance Liquid Phase Separations and Related Techniques, Birmingham, June 22<sup>nd</sup>-27<sup>th</sup> 1997.

- Chienthavorn, O. and Smith, R.M., "Subcritical Water Chromatography with Fluorescence Detection" presented at Research and Development Topics in Analytical Chemistry meeting organised by the Analytical Division, Royal Society of Chemistry, University of Northumbria, Newcastle, July 2<sup>nd</sup>- 3<sup>rd</sup> 1997.
- Chienthavorn, O. and Smith, R.M., "pH Effect in Superheated Water Chromatography", 1998 National Congress, and 35th Research and Development Topics in Analytical Chemistry, University of Durham, April 6<sup>th</sup>-7<sup>th</sup>, 1998.
- Chienthavorn, O. and Smith, R.M., "pH effects in Superheated Water Chromatography", presented at 8th International Symposium on Supercritical Fluid Chromatography and Extraction, St. Louis, USA, July 12<sup>th</sup>-16<sup>th</sup> 1998.
- Smith, R. M., Chienthavorn, O., Wilson, I. D. and Wright, B., "Coupling Superheated Heavy Water Chromatography and Nuclear Magnetic Resonance Spectroscopy", presented at 8th International Symposium on Supercritical Fluid Chromatography and Extraction, St. Louis, USA, July 12<sup>th</sup>-16<sup>th</sup> 1998.
- Chienthavorn, O., Smith, R. M., Wilson, I. D., Wright, B., and Taylor, S. D., "High Performance Superheated Water Chromatography - Proton Magnetic Resonance Spectroscopy", presented at 36<sup>th</sup> Research and Development Topics in Analytical Chemistry, organised by the Analytical Division, Royal Society of Chemistry, University of Greenwich, London, April 12<sup>th</sup>-14<sup>th</sup> 1999.
- Chienthavorn, O., Smith, R. M., Wilson, I. D., Wright, B., "Examination of Complex Mixtures Using Superheated Heavy Water LC-NMR Spectroscopy" presented at the Australian International Symposium on Analytical Science, (incorporating 15 AC and Chromatography '99), organised by the Royal Australian Chemical Institute, Analytical Chemistry Division and the Scientific Suppliers Association of Australia, Melbourne, July 4<sup>th</sup>- 9<sup>th</sup> 1999



