

LOUGHBOROUGH
UNIVERSITY OF TECHNOLOGY
LIBRARY

AUTHOR/FILING TITLE

MOHSIN, M V

ACCESSION/COPY NO.

005991/02

VOL. NO.

CLASS MARK

6 JUL 1981 LOAN COPY

000 5991 02



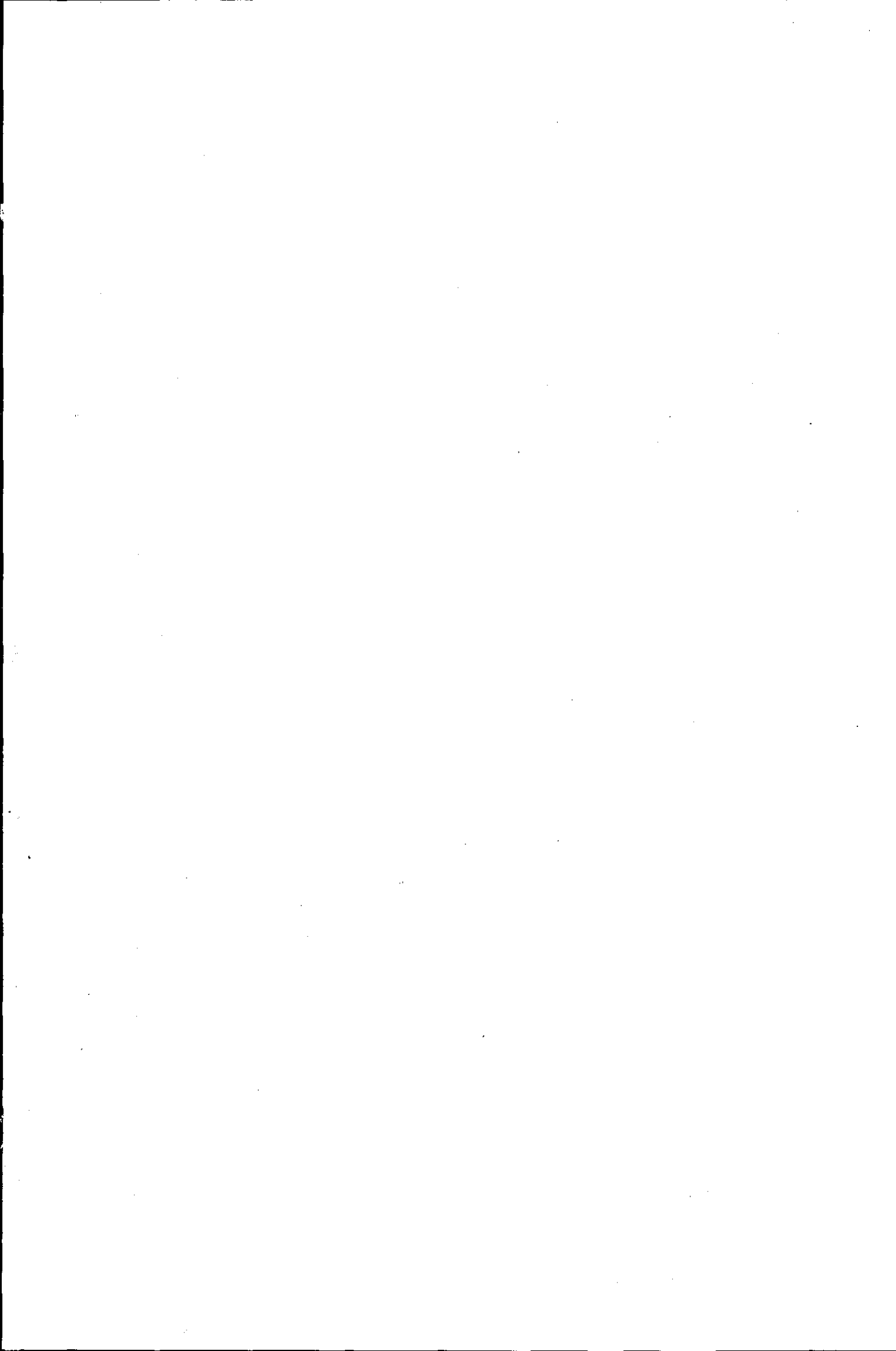

SOME ASPECTS OF THE HOT ATOM CHEMISTRY
OF LIQUID AROMATIC HALOGEN COMPOUNDS

BY

MAJID K. MOHSIN

A Master Thesis Submitted in partial fulfilment
of the requirements for the award of the degree of
M. Phil. of Loughborough University of Technology

March, 1983

Supervisors: Mr. Graham Oldham

(c) By Majid. K. Mohsin, 1983

Loughborough University
of Technology Library
Dx. No. NW 84
Class.
Acc. No. 005991/02

ABSTRACT

The chemical reactions following nuclear reactions have been studied for some liquid aromatic halogen compounds with and without I_2 present as radical scavenger as well as in highly diluted mixtures with a variety of organic solvents, such as simple aliphatic hydrocarbons and aromatic hydrocarbons.

The results obtained in these systems suggest an interaction between the molecules making up the solvent cage with the intermediates forming the substituted product. This interaction consists most likely of an H abstraction by the halogen radical in the solvent cage, which competes with the reactions of thermal halogens leading to radio-halogen substitution products, resulting in reduced yields of the latter types of compound. In the present study an attempt has been made to determine the role of cage recombinations competing with the hot radio-halogen-for-non-radio halogen compounds. The effect of I_2 scavenger present in a small amount (0.5 Mole%) has been compared with the effect of solvents possessing different reactivities towards thermal halogen atoms, the solvents being present in high concentrations of about (90 Mole %).

ACKNOWLEDGEMENTS

I wish to express my thanks to my supervisors;

Prof. F. Wilkinson, Mr. G. Oldham, Dr. D.S. Brown, and Dr. P. Warwick.

for their invaluable guidance throughout the course of this work.

If not expressed in words, the gratitude is most certainly present in feeling.

My thanks to the laboratory staff, Mr. E. Miller, Mr. T. Mistry and Mr. R. Owen for their assistance and co-operation and to Mrs. Linda Brook for typing this thesis.

I acknowledge with thanks the IRAQI atomic Energy Commission for their scholarship, without which this research would not have been possible.

finally, I would like to express my sincere gratitude to my parents, my brothers and sisters and last but not least, to my wife, for her continuous moral support.

Majid K. Mohsin.

March 1983

Chemis. Dept.,
LOUGHBOROUGH UNIVERSITY OF TECHNOLOGY

CONTENTS

	Page No.
ABSTRACT	i
CHAPTER 1	
INTRODUCTION	1
1.1 Literature Survey	1
1.2 The Object of this Work	19
CHAPTER 2 .. PRINCIPLES	
2.1 Summary	21
2.2 Techniques for the Production of Hot Atoms	22
2.3 Identification of Hot Processes	28
2.4 Theories of Hot Atom Reactions	31
2.5 Hot Atom Reactions of Halogens	33
CHAPTER 3 .. EXPERIMENTAL	
3.1 Materials	43
3.2 Purification of Materials	44
3.3 Production of Radioactive Isotopes by Neutron Irradiation	45
3.4 Neutron Generator	45
3.4.1 The Positive Ion Accelerator	46
3.4.2. Power Supply	52
3.4.3. Control Console	52
3.4.4. Shielding	53
3.4.5. Setting up Procedure of the Neutron Generator	54
3.5 Sample Transfer System	55
3.6 Neutron Irradiation of Sample Compounds	58
3.7 Analysis	63

	Page No.
3.7.1. Extraction Procedure	63
3.7.2. Gas-Liquid Chromatography	64
3.7.2.1. Column	65
3.7.2.2 High Pressure Liquid Chromatography	85
3.8 Determination of Activity	90
3.8.1. Liquid Scintillation Counter	90
3.8.1.1. Sample Container	99
3.8.1.2. Cerenkov Radiation	101
 CHAPTER 4 .. RESULTS	
4.1 Scavenger Study	102
4.2 Caging Effect	113
4.3 The Szilard-Chalmers Effect on o-Iodotoluene	123
 CHAPTER 5 .. DISCUSSION	
5.1 Scavenger Effects	139
5.2 Caging Effect	142
5.3 Szilard-Chalmers Effects	146
 CONCLUSIONS	149
REFERENCES	150

LIST OF TABLES

	Page No
CHAPTER 3	
Table 1	Isotopes of Iodine 59
Table 2	Isotopes of Bromine 61
Table 3	The Effect of Range (Sensitivity) on Peak Height 70
Table 4	The Effect of Column Temperature on Retention Time 71
CHAPTER 4	
Table 5	Effect of Pyridine as a Scavenger on o-Iodotoluene 104
Table 6	Effect of Oxygen as a Scavenger on o-iodotoluene 105
Table 7	Effect of Bromine as a Scavenger on o-iodotoluene 106
Table 8	Effect of Iodine as a Scavenger on o-iodotoluene 107
Table 9	Effect of Diluent on the organic yield of o-bromotoluene (Without I ₂ Scavenger) 115
Table 10	Effect of Diluent on the organic yield of o-bromotoluene (With 0.5 Mole % of I ₂) 116
Table 11	Effect of Diluent on the organic yield of m-bromotoluene (Without I ₂ Scavenger) 117
Table 12	Effect of Diluent on the organic yield of m-bromotoluene (With 0.5 Mole% of I ₂) 118
Table 13	Effect of Diluent on the organic yield of o-iodotoluene (Without I ₂ Scavenger) 119
Table 14	Effect of Diluent on the organic yield of o-iodotoluene (With 0.5 Mole % of I ₂) 120
Table 15	Effect of Diluent on the organic yield of m-iodotoluene (Without I ₂ Scavenger) 121

		Page No
Table 16	Effect of Diluent on the organic yield of m-iodotoluene (With 0.5 Mole % of I ₂)	122
Table 17	The percent organic yield from irradiation of 2 ml of o-iodotoluene	126
Table 18	The activity under peaks collected from injected, a) 5 μ l of organic layer b) 15 μ l of mixture of 50 μ l each (iod.13 + o-iod.t in pet.ether)	127
Table 19	Recovery of the activity of an irradiated sample	128
Table 20	Effect of solvents on counting efficiency	129
Table 21	Variation of number of counts with volume using 25% solution	130
Table 22	Variation of number of counts with volume using 15% solution	131
Table 23	Variation of number of counts with volume using 15% solution	133
Table 24	Variation of number of counts with time	134
Table 25	Organic yield from irradiated o-iodotoluene	135
Table 26	Activity from 2 minutes GLC sample of 15% solution	137
Table 27	Activity of irradiated sample of o-iodotoluene before and after extraction	138

LIST OF FIGURES

	Page No
CHAPTER 3	
Figure 1	Schematic of generator 47
Figure 2	P.I.G. Ion Source 48
Figure 3	An illustration of the target disc 51
Figure 4	Sample insertion and reversal system 57
Figure 5	Front view of A-700 66
Figure 6	Automatic control unit A-700 67
Figure 7	Cutaway views of injector input and output check valves A-700 68
Figure 8	25 μ l of a mixture of CH_3I , $\text{C}_2\text{H}_5\text{I}$, $\text{C}_3\text{H}_7\text{I}$ and $\text{C}_4\text{H}_9\text{I}$ in ether 72
Figure 9	25 μ l of a mixture of CH_3I , $\text{C}_2\text{H}_5\text{I}$, $\text{C}_3\text{H}_7\text{I}$ and $\text{C}_4\text{H}_9\text{I}$ in ether 73
Figure 10	25 μ l of a mixture of CH_3I , $\text{C}_2\text{H}_5\text{I}$, $\text{C}_3\text{H}_7\text{I}$ and $\text{C}_4\text{H}_9\text{I}$ in ether 74
Figure 11	200 μ l of 15% solution of Iodobenzene + Iodotoluene in Hexane 76
Figure 12	300 μ l of 15% solution of Iodobenzene + Iodotoluene in Hexane 77
Figure 13	400 μ l of 15% solution of Iodobenzene + Iodotoluene in Hexane 78
Figure 14	500 μ l of 15% solution of Iodobenzene + Iodotoluene in Hexane 79
Figure 15	Iodotoluene in Hexane 200-360 80
Figure 16	Standard absorption graph of Iodotoluene at 259 nm 81
Figure 17	Iodobenzene in Hexane 200-400 82
Figure 18	Standard absorption graph of Iodobenzene in Hexane at 259 nm 83
Figure 19	Absorption graph from 2 Min. (G.L.C.) samples (200 μ l) 84

Figure 20	Typical bench placement of the model 300 and accessories	86
Figure 21	Flow diagram	87
Figure 22	High pressure sample injection valve flow pattern	89
Figure 23	20 μ l of 5% of Iodotoluene + Iodoethane in methanol	91
Figure 24	20 μ l of 10% of Iodotoluene + Iodoethane in methanol	92
Figure 25	20 μ l of 15% of Iodotoluene + Iodoethane in methanol	93
Figure 26	20 μ l of 20% of Iodotoluene + Iodoethane in methanol	94
Figure 27	20 μ l of 25% of Iodotoluene + Iodoethane in methanol	95
Figure 28	Front panel of SL 20 liquid scintillation spectrometer	96

CHAPTER 4

Figure 29	Effect of pyridene on the organic yield	108
Figure 30	Effect of oxygen on the organic yield	109
Figure 31	Effect of Bromine on the organic yield	110
Figure 32	Effect of Iodine on the organic yield	111
Figure 33	Effect of Scavenger on o-Iodotoluene	112
Figure 34	15 μ l from the organic layer injected directly in the G.L.C.	124
Figure 35	5 μ l from a mixture of the organic layer and Iodobenzene in ether	125
Figure 36	20 μ l of 15% solution of Iodoethane + Iodobenzene in methanol	132

CHAPTER 1
INTRODUCTION

1.1 Literature Survey

The Szilard-Chalmers Chemistry of Alkyl halides has been studied extensively in a wide variety of systems. Reviews by Willard⁽¹⁻³⁾, Wolf⁽⁴⁾, Siuda⁽⁵⁾ and Campbell⁽⁶⁾ provide an extensive survey of the work done in this field. Therefore only the literature which is directly pertinent to the present work will be mentioned here. The subject discussed will be the mechanism by which labelled organic products are formed following the neutron capture by halogens in liquid aromatic systems, and the role played by failure of bond rupture and by caging effects. The work reported is an attempt to study these questions in liquid halogen compounds, particularly the ortho and meta halo-toluene systems.

The high binding energy of neutrons in halogens, as in most nuclides with masses in the range from (20 - 150 atomic mass units) makes it highly probable that a halogen atom recoiling from the gamma rays emitted following neutron capture by halogens will have a kinetic energy far in excess of the energy required for it to break its chemical bond and escape from its parent partner. Although it is possible for partial cancelling of recoil energies to occur in a multi-gamma emission process, it is generally observed that the probability of failure of bond rupture that follows the (n, γ) process is very low.

Gordus and co-workers⁽⁷⁾ have determined the probability of bond rupture following radiative neutron capture for gaseous organic halides.

The highest value⁽²³⁾ for the fraction of capture events which do not lead to bond rupture was 1.1% in the case of $\text{CH}_3\text{-I}$. These results are consistent with earlier gas phase work by Gordus and Willard⁽⁸⁾ and Wexler and Davies⁽⁹⁾.

In the liquid phase, it is possible that the fraction of recoil atoms which fail to escape their parent fragment may be increased by the caging effect of the surrounding molecules which keeps the fragments in close proximity to one another, thus increasing the probability of recombination. The energy distribution of the recoil atoms produced via n, γ reactions is not known. However, since the maximum possible recoil energies for atoms produced by radiative neutron capture are typically of the order of 100 eV or more, it is not probable that a sufficiently high fraction of the atoms are produced with energies that are low enough for the caging effect to be important.

Thus, it is unlikely that caging can result in a large increase in retention in the liquid phase over that seen in the gas phase.

Retention resulting from caging effects cannot be distinguished from that resulting from failure of bond rupture.

A study of the failure of the bond rupture after neutron capture by the iodine in aqueous CH_3I has been interpreted as indicating that an appreciable fraction of the recoil atoms failed to

escape their parent partner.

Sturn and Davis⁽¹⁰⁾ irradiated solutions containing (0.09) mole fraction⁽¹¹⁾ methyl iodide in water, and I_3^- which was added as a scavenger. They observed that 12% of the ^{128}I produced by the $^{127}I (n, \gamma) ^{128}I$ process is found in organic combination independent of the scavenger concentration in the range of 1.8×10^{-3} to 1.8×10^{-8} mole fraction. They state that, since the only source of organic fragments in the system was methyl iodide, and since the higher concentrations of I_3^- were sufficient to scavenge all the organic radicals which escaped recombination with their partners, these results must indicate that 12% of the ^{128}I atoms either fail to rupture the parent carbon-iodine bond following the neutron capture or recombine with the parent fragment. Results of other work in the liquid phase indicate that it is improbable that the failure of bond rupture and geminate retention could account for the results observed by Sturn and Davis.

Iyer and Martin⁽¹²⁾ irradiated mixtures of CH_3I and C_3H_7I with the dilute component synthesized from ^{127}I . Combining the yield of the parent compound of ^{130}I formed from neutron capture by ^{129}I with the yield when I_2 was the source of the ^{130}I , they found that the percentage of neutron capture events in which the recoil atom either failed to rupture the parent bond or recombined again with the parent fragment was about 4%.

Chang and Willard⁽¹³⁾ reported that when hexane containing $I_2 (^{129}I)$ and $i-C_3H_7 ^{127}I$ or $C_2H_5 ^{127}I$ is irradiated with neutrons, the fractions of ^{128}I and ^{130}I found as $i-C_3H_7 ^{128}I$ and $i-C_3H_7 ^{130}I$

or C_2H_6 ^{128}I and C_2H_5 ^{130}I are nearly equal, indicating that there is little or no contribution to the organic yield due to geminate retention. Similarly, Shaw⁽¹⁴⁾ reports that less than 3% of the ^{128}I atoms produced by radiative neutron capture in alkyl halide-benzene solutions fail to escape their parent partners. An explanation for the organic yield observed in the aqueous methyl iodide solutions which is more consistent with evidence from other systems is suggested by results reported by Geissler and Willard⁽¹⁵⁾ for the (n, γ) activation of halogen atoms in alkyl halide-pentane solutions. They irradiated solutions of methyl iodide, ethyl iodide and propyl chloride in pentane with neutrons and they determined the yield of labelled organic products by gas chromatography. They observed that in each of the iodide solutions, the largest fraction of the ^{128}I activity from the ^{127}I (n, γ) ^{128}I reaction was in the form of the parent alkyl iodide, even in the presence of I_2 as scavenger. They also found that the relative yields of ^{128}I products are similar to those for ^{131}I produced in the ^{60}Co radiolysis of solutions of alkyl iodides in pentane containing ^{131}I scavenger. To explain this, they propose that radiolytic decomposition of the solution envelope around the I atom by electrons emitted as the atom decays to the nuclear ground state leaves the atom at the centre of a high local concentration of radicals. Thus the nature of the labelled organic products is determined by the reactions of the iodine atoms with radicals produced by its own radiations. It has been observed that at least 50% of the ^{128}I atoms produced by the (n, γ) process are

born with a positive charge⁽⁹⁾ as a result of internal conversion and Auger processes. The charge spectrum of ^{128}I ions has not been measured, but the spectrum of iodine ions from CH_3I resulting from internal conversion and Auger emission excited by the production of inner shell vacancies in iodine by X-rays has been shown⁽¹⁶⁾ to range from +1 to +13 with the maximum yield at +5.

Earlier work⁽¹⁷⁾ showed similar results for ^{131}Xe ions produced by the $^{131\text{m}}\text{Xe} \xrightarrow{\text{IT}} ^{131}\text{Xe}$ process. The electrons emitted by the atom in such a charging process, and the subsequent charge neutralization processes, could have a profound effect on the solution around the atom. Evidence^(12,13) that the $^{127}\text{I} (n,\gamma) ^{128}\text{I}$, $^{129}\text{I} (n,\gamma) ^{130}\text{I}$ and $^{130\text{m}}\text{I} \xrightarrow{\text{IT}} ^{130}\text{I}$ processes endow the daughter atoms with similar chemical activities and is consistent with the expectations of Geissler-Willard autoradiation hypothesis.

In a recent study of the pulse radiolysis of aqueous methyl iodide solutions, Thomas⁽¹⁸⁾ has obtained evidence that iodine atoms form a complex with methyl iodide molecules of the form $\text{I}(\text{CH}_3\text{I})$. If this is the case then it is possible that ^{128}I atoms which have been thermalized and neutralized following formation by the (n,γ) process could undergo thermal exchange with methyl iodide in aqueous solutions. In the decay of a complex of the form $\text{I}(\text{CH}_3\text{I})$, it is conceivable that either of the two iodide atoms could be lost. Thus the 12% organic yield for the $^{127}\text{I}(n,\gamma)^{128}\text{I}$ process observed by Sturn and Davis in the aqueous methyl iodide systems could be the result of the iodine atoms complexing with methyl iodide. Gordus and Hsiung⁽⁷⁾ found that if an isolated atom

absorbs a thermal neutron and the neutron binding energy is released as a single gamma ray, then as a result of the law of conservation of momentum, the atom will receive a recoil kinetic energy which is in excess of thermal energies. For example, the neutron-binding energy associated with the $^{127}\text{I} (n,\gamma)^{128}\text{I}$ process is 6.6 MeV; an isolated ^{128}I atom releasing this energy as a single gamma ray would acquire 182 (eV) of kinetic energy. If the atom which undergoes an (n, γ) reaction is bound chemically, it is not immediately obvious how the gamma-ray recoil is transferred to the atom or the molecule. The observations of Szilard-Chalmers, and others had shown that the majority of the atoms activated by the (n, γ) process rupture from their parent compound. This indicates that at least a fraction of the gamma-recoil momentum must be deposited in the bond joining the activated atom to the molecule. For a given isotope, the gamma-ray momentum which is required for the bond rupture should depend on the chemical radical to which the activated atom would always rupture from its parent compound. The only exception would be perhaps the case where the activated atom was bonded to an atom of small atomic weight as in the hydrogen halides, for example. However indirect experimental evidence indicates that in the (n, γ) activation of aqueous ethyl iodide ca. 1% of the ^{128}I did not rupture from the parent molecule. Such failure to bond rupture can be explained. In the (n, γ) activation, and particularly in the activation of halogens, the neutron-binding energy is released most frequently not as a single gamma-quantum, but as a gamma-ray cascade. Because of the partial cancellation of the gamma-ray momenta, some of the atoms can receive a recoil momentum

which is less than that needed for the bond rupture. Most studies of the Szilard-Chalmers effect in organic halides have been made with pure halides either alone or mixed with pure free halogen. Willard and his colleagues⁽²⁾ showed that the fraction of the radio-halogen that is present in organic combination (termed the retention) is extremely sensitive to small quantities of free halogen added to the system before the neutron irradiation process, and that the retention is approximately reduced to half by the addition of 0.05 to 0.1 mole fraction of halogen (as scavenger). Further increase in the concentration of the free halogen which is added before the irradiation causes relatively little reduction in the retention, which for many iodides and bromides⁽¹⁴⁾ shows an approximately linear decrease to zero as the halogen concentration is increased from 0.1 to 1.0 mole fraction.

Willard⁽²⁾ accounted for the general features of these variations in the retention by postulating two stages in the processes that follows the neutron irradiation (i.e. the neutron capture). In the first, an atom activated by the neutron capture process will produce free radicals by disruption of the surrounding molecules. Immediate combination with one of these forms organic species whose yield will not be sensitive to the scavenger; alternatively the atom may escape reaction with a radical at this stage, but combine later, after both have made many collisions with the surrounding molecules.

In this thermal, or diffusive stage, small concentrations of free halogen may be sufficient to intercept and react with the

radicals, so causing a disproportionate reduction in the retention.

In iodo-methane, Levey and Willard⁽³⁹⁾ and Brustad and Baarli⁽⁴⁰⁾ found that the chief organic products containing radioactive iodine atoms were mono- and di-iodomethanes and that the chief product from thermal reactions was iodomethane, the yield of di-iodomethane being relatively insensitive to the presence of small quantities of iodine. The parent compound has also been shown to be the chief product from thermal reactions in iodo-ethane⁽¹⁴⁾ and bromo-ethane⁽⁴¹⁾. The mechanism of the reactions occurring in the first (hot) stage are still obscure, but recent work on bromides⁽⁴²⁾ has shown that direct replacement reactions, first postulated by Libby⁽⁴³⁾, may also occur.

There have been relatively few studies of the Szilard-Chalmers reactions in solvent systems. One of the earliest and most systematic of these was that of Miller and Dodson⁽⁴⁴⁾ who studied systems containing carbon tetrachloride dissolved in silicon tetrachloride, benzene and cyclohexane; they attempted to explain their results in terms of a modified form of Libby's theory of replacement reactions.

Unfortunately this work preceded that of Willard, and they made no allowance for possible thermal reactions, the occurrence of which might considerably modify the conclusions drawn.

Aditya and Willard⁽⁴⁵⁾ made a systematic study of the yields of hot reactions which were greater in solvents of higher molecular weight; they also demonstrated that the hot retentions were susceptible

to change in irradiation temperature.

Macrae and Shaw⁽¹⁴⁾ have made a preliminary examination of some of iodine-benzene systems. They found that the retentions of elementary iodine dissolved in benzene showed no sharp decrease with increasing iodine concentration; a similar effect has been observed by Milman⁽⁴⁶⁾ in bromine-benzene mixtures.

Retentions of benzene solutions of iodo-methane, iodo-ethane or iodo-benzene containing a little (10^{-5} molar fraction) iodine increased sharply from 0 to 0.1 molar fractions of iodide concentration. The sharp rise in retention was shown to be due to increased yields of the parent iodide.

To account for these results, it was postulated that the activated atom caused the dissociation of benzene into hydrogen atoms and phenyl radicals which then reacted as follows:

(Ph. is phenyl radical)

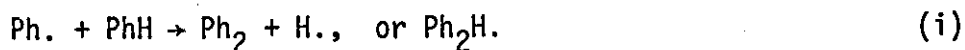

where R is methyl or ethyl and Ph. is phenyl radical



Combination of the active atom with the products from (i) would then form hydrogen iodide and so contribute to the inorganic yield whereas reaction with the products from (ii) and (iii) could lead to the formation of parent iodide. Evidence for the existence of biphenyl iodonium radicals is summarized in an earlier paper⁽¹⁴⁾. The exact nature of the activation gained by an atom after neutron capture is obscure. If the nucleus emits a cascade of a few gamma rays in random directions, the atom will be left with a distribution of recoil energies between zero and a few hundred electron volts. Such activation is generally sufficient to dissociate the atom from its parent molecule, and to cause the dissociation of some of the surrounding molecules with which it collides.

Wexler⁽⁴⁷⁾ has shown that the atom may also become highly charged owing to internal conversion followed by the emission of Auger electrons. The active atom may then cause ionisation of neighbouring molecules by abstraction of electrons, so that liquid in the vicinity of neutron capture may contain positive ions, electrons and free radicals, and may therefore not be dissimilar to that in a "spur" produced by a fast electron.

Under these circumstances, explanations of radiolytic effects in a solvent may have some features in common with those required to account for the distribution of activity from the neutron capture in the same solvent. Iodine is known to exist normally as a charged complex ($I^+ I^-$) and on neutron irradiation this complex may be expected to exist as an excited multiple charged species.

The neutron irradiation of iodine in the presence of a substance which will react either with the positively or negatively charged species of iodine should lead to a very important and interesting result. In (n,γ) reactions, one usually assumes the formation of free radicals or charged particles. However, the reactivities of the free radicals are expected to be the same for these substances. In studying the factors which affect the reproducibility of extractions using an aqueous reagent of the radio iodine from neutron-irradiated iodobenzene, P.F.D. Shaw⁽¹⁴⁾ reported that in the presence of iodine, the extractions are easily reproducible, but without iodine the amount of the extractable radio-iodine is variable because of the variable formation of aliphatic radio-iodine compounds which are probably produced on the rupture of the benzene rings by the energetic recoiling radio-iodine atoms. On the other hand, Bodo Diehn and V George Thomas⁽¹⁹⁾ in a recent study reported that the product-spectrum generated upon X-irradiation of a degassed sample of liquid iodobenzene consisted of the following compounds, listed in the order of emergence from an SE-30 gas chromatographic column:

benzene, iodine, iodobenzene, o-, m-, and para diiodobenzenes, biphenyl, o-, m-, and p-iodobiphenyls.

The authors in this study put the formation of aliphatic radio-iodine compounds that may be produced by the rupture of the benzene rings in doubt.

The low values normally obtained for the efficiency of extraction of the radio-iodine from iodobenzene compared with those obtained for other organic monohalides may be due to the formation of Iodonium, radical $\text{ph}_2 \text{I}^\cdot$. The evidence for this is that the phenyl radicals which are produced by photolysis, in iodobenzene give compounds containing the iodo-biphenyl (ph-I-ph) structure. In the case of iodobenzene there appears to be an alternative fate for any free phenyl radicals produced, namely addition to the iodobenzene molecule to form an iodonium radical. It might be expected that this will be stabilized in the following way:

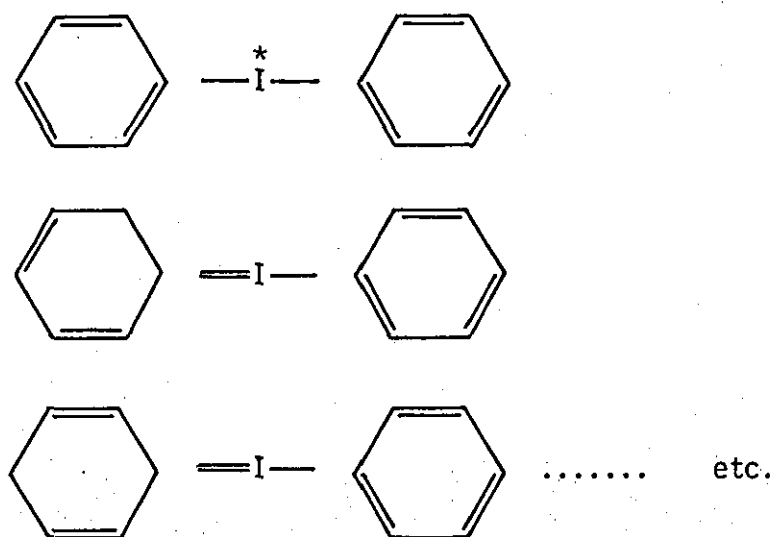

This might be possible for the phenyl radicals in iodobenzene but not in bromobenzene for example, because iodine can exist in a ter-valent state of medium stability. If this occurred, then two factors would tend to reduce the extraction efficiency in iodobenzene. These factors are:

1. The number of hydrogen and iodine atoms which might be produced by the above mechanism will be reduced.
2. The probability of the formation of the diphenyliodonium iodide molecules as shown in the following reaction:

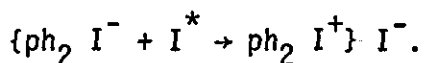

This compound (Diphenyliodonium iodide) would carry the heat of recombination and may be decomposed into two molecules of iodobenzene because it is known that the above substance has a low thermal stability and decomposes rapidly at about 120°C⁽²⁰⁾. To confirm the general validity of this argument, an attempt was made by Shaw in which he irradiated with neutrons iodine-iodobenzene solutions which had previously been saturated with nitric oxide. If the iodonium radicals were stabilized, then the above decomposition may occur slowly because it will be limited by the frequency of collisions between the radicals and the radio-iodine atoms. Thus in this case, a combination of some of the radicals with nitric oxide molecules may occur before the collisions and hence the above decomposition would be reduced, and the extraction efficiency would correspondingly increase.

Under similar conditions, no increase in efficiency of extraction was obtained with bromobenzene, indicating that in this case, the radicals capable of playing an important role in the recoil process were short-lived.

Evidence for the formation of ph-I-ph structure under similar conditions has been obtained from the photolysis of iodobenzene

using ultra-violet light. Furthermore, J E C Macrae and P F D Shaw⁽²¹⁾ explained the shape of the scavenger curve in iodobenzene by the intermediate formation of diphenyl iodonium radicals which were assumed to react very slowly with the elementary iodine.

Many scavenger experiments were carried out to decide whether at least a fraction of the diiodobenzenes that result from the neutron irradiation of iodobenzene was formed by hot reaction. It seems that the system is already scavenged by the iodine that is formed during irradiation so, in this case and according to previous studies, there will be no change in the products if a solution of iodobenzene and iodine is irradiated instead of pure iodobenzene. The scavenger effect is noticed mostly in comparisons between hot and thermal reactions. The fraction of the radiohalogen present in organic combination (retention) could be divided into two parts according to the scavenger effects:

- a. The hot reaction part which occurred during the slowing down of the recoil atoms and was not sensitive to low concentrations of scavenger.
- b. The thermal reaction part that occurred during the diffusion and was highly sensitive to scavenger.

The amount of retention that can be attributed to the hot reaction was found to be quantitatively dependent on the number/molecules.

Wilkey D. Dennis⁽²²⁾ studied the iodine exchange with methyl

iodide and confirmed the importance of exchange in the determination of the Szilard-Chalmers yield in alkyl iodides. They showed that the apparent isotropic exchange as measured by the organic retention of activity depends on iodine concentration. It is believed by the authors that the best argument for a hot mechanism of diiodobenzene formation is based on the fact that the isomeric diiodobenzenes are observed in the approximate statistically expected ratio of 2:2:1 for o-, m-, and para-isomers. This is indicative of indiscriminate attack of energetic iodine atoms on iodobenzene molecules. A general mechanistic conclusion on the reaction of recoil iodine in alkyl halides is not possible, but it would seem that large effects are due to trace impurities in the materials used as well as the exchange process between alkyl iodides and the inorganic iodine compounds. In addition, the autoradiolysis effects are very important in the determination of the final yield of the labelled products. It also depends on some other factors such as the translational excitation, the degree of ionization and the electronic state of the particle.

Aromatic systems mirror to a certain extent the effects found with aliphatic compounds i.e. greater yields from aromatic iodides than from aromatic hydrocarbons. Benzene would seem to be self-scavenging for thermal iodine atoms and other radicals. Variations in organic yields with different iodides as a source for the recoil iodine have been studied by Macrae and Shaw⁽¹⁴⁾. The organic yield from benzene is remarkably indifferent to the nuclear source of the radio-iodine: thus $^{127}\text{I} (n^*, 2n) ^{126}\text{I}$, $^{127}\text{I}(n, \gamma) ^{128}\text{I}$ and $^{130m}\text{I}(I.T) ^{130g}\text{I}$ all give comparable organic yields and very similar labelled product

yields^(23,24). This was found to be true for benzene and also for alkyl-substituted benzenes, e.g. toluene. The side-chain was found to be much more susceptible to attack by recoil iodine than the benzene ring⁽²³⁾.

Quite different and widely varying results have been found for the iodine species that are produced by β^- decay. A very high organic yield ($\sim 50\%$)⁽⁶⁸⁾ was found for the reaction of ^{131}I with benzene; the ^{131}I had been formed by β decay from ^{131}Te , which in turn was a fission product. The yield was reduced to about 20% by the addition of scavenger. Similar results have been observed for $^{125}\text{X}_g$ (E.C) ^{125}I with benzene⁽⁶⁹⁾. The reactions of ^{131}Te (β^-) ^{131}I have been studied directly using a variety of tellurium molecules as sources, e.g. dibenzyltellurium⁽⁷⁰⁾. Bond rupture was shown to occur in greater than 98% of the decay events but the yield of labelled benzene was only about 1%. Addition of scavengers to the benzene solution of labelled dibenzyltellurium did not alter this yield. Iodine was not, but allyl iodide was, an effective scavenger for thermal iodine atoms. Allyl iodide reduces the yield of iodobenzene by half. Neutron irradiation of iodobenzene gives an 80% organic yield, most of which is labelled iodobenzene⁽⁷¹⁾. Iodine causes a dramatic drop in organic yield, indicating a large contribution from radical-thermal iodine atom reactions. A variety of possible reaction mechanisms has been postulated^(71,72). The $(n^*, 2n)$ reaction gives⁽³⁸⁾ a much lower organic yield (32%). With the other halogenobenzenes recoil iodine also gives much lower organic yields; when hydrogen is replaced in these molecules para-substitution is preferred. ^{131}I from fission (via ^{131}Te β decay) reacts⁽⁷³⁾ with bromobenzene and bromonaphthalenes to give the corres-

ponding iodo-compounds and also some iodo-bromo-derivatives by hydrogen replacement. ^{125}I formed by electron capture in $^{125}\text{X}_8$ was found⁽⁶⁹⁾ to be very reactive towards $\text{C}_6\text{H}_5\text{X}$ ($\text{X} = \text{F}, \text{Cl}, \text{or Br}$; organic yields 29%, 64%, 84%) but the addition of traces of iodine scavenger (0.01%) caused these yields to drop to only 10-20%. These results are thus not dissimilar to those from (n, γ) reactions.

When organic bromides are bombarded with fast neutrons, a proportion of the radio-bromine produced can be extracted with an aqueous reagent, e.g. sulphite or bromide solutions. This is because the recoil energies of the bromine atoms from the γ -rays emitted on neutron capture are greater than the chemical bonding energies of C-Br bonds, so that dissociation occurs, leaving some radioactive bromine combined in new chemical species.

Three possible radioactive isotopes of bromine may be produced by this means:

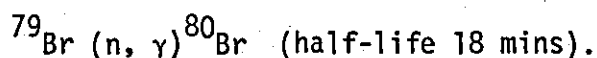
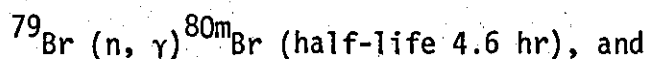
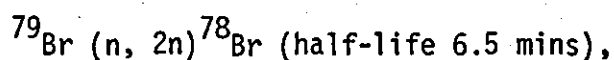

Libby and his co-authors^(31,32) working with iso- and n-propyl bromide, have reported that retentions of these isotopes are the same.

Capron and Crevecoeur⁽³³⁾ using bromobenzene found a difference in the retentions of $^{80\text{g}}\text{Br}$ and $^{80\text{m}}\text{Br}$, that the longer-lived isotope being the greater. They also found that the ratio of isotopic

retentions depended on the energy distribution of the bombarding neutrons, and concluded that the ^{80g}Br and ^{80m}Br atoms produced had different recoil energies which arose from variations in the γ -ray cascades following neutron capture. Capron and Oshima⁽³⁴⁾ and Capron and Crevecoeur⁽³⁵⁾ found similar effects in bromoform, and in iso- and n-propyl bromide. However, they admitted that the purity of the last two compounds was poor, and, as Libby and his co-workers^(31,32) have pointed out, the presence of impurities which could react with inorganic bromide to return it to organic combination would favour greater retentions for the longer-lived isotopes.

Chien and Willard⁽³⁶⁾ explained the organic retention of ^{80g}Br and ^{80m}Br in the propyl bromide, bromoform and bromobenzene and found that the isotopic retentions were the same in the aliphatic bromides, but were unable to confirm this for bromobenzene owing to the poor reproducibility of results. They concluded that the retention differences observed by Capron et al were due to impurities. Evidence for the radiolytic production of compounds causing an increased retention in bromobenzene has been given by Shaw and Collie⁽³⁷⁾ who showed that the effect of such a compound could be reduced by the addition of bromine before irradiation.

Hydrogen and halogen substitution by recoil chlorine, bromine and iodine, produced via (n,γ) and $(n, 2n)$ reactions have been studied in three liquid monohalotoluenes. Comparison between (n,γ) and $(n, 2n)$ produced recoil halogen in unscavenged $\text{C}_6\text{H}_5\text{Cl}$ and $\text{C}_6\text{H}_5\text{I}$ shows that the halogen replacement yields are considerably higher in the case of (n,γ) -reaction for both recoil chlorine and iodine. In the presence of 1 mole % I_2 scavenger⁽³⁸⁾, however the

difference between (n,γ) and $(n, 2n)$ -reaction completely disappears. Scavenger competition has been carried out⁽³⁸⁾ to obtain further information on the yield-determining factors in hot halogen replacement. It could be shown that the halogen replacement yield for recoil bromine and iodine is proportional to the geometrical cross-section and energy loss for the halogen-halogen collision and is inversely proportional to the C-halogen bond energy. The results are explained on the basis of one-step replacement reactions and immediate caged radical combinations following a hot displacement.

As in the case of recoil chlorine, hydrogen substitution by recoil bromine and iodine shows little or no selectivity and reactivity effects. The *i*-, *m*- and *p*-, isomer distribution remains practically unchanged when comparing (n,γ) - and $(n, 2n)$ -reactions. In each case almost statistical isomer distribution is observed and the results are explained on the basis of a hot homolytic aromatic substitution proceeding via a first formed π -complex.

1.2 The Object of this Work

The object of the present work is to investigate the reactions of halogen atoms activated by radiative neutron capture in the liquid phase in order to determine the role played by geminate retention in the formation of the labelled organic products. Different isomers of the halo-toluene system are selected for the work as a simple possible system in liquid aromatic halogen

compounds, in which to distinguish between the organic products which result from geminate retention, and the organic products produced by the reactions of recoil atoms after escaping from the parent partners.

An attempt has been made to determine the role of cage recombinations competing with the hot halogen atoms for non-radioactive ones as replacement in liquid aromatic halogen compounds. We compared the effect of I_2 scavenger present in a small amount (0.5 Mole %) with the effect of some solvents which possess different reactivities towards thermal halogen atoms, present in high concentrations (about 90 Mole %).

CHAPTER 2PRINCIPLES2.1 Summary

Hot atom chemistry is the study of the reactions of atoms of high translational energy. It is an aspect of a large field of physical chemistry dealing with those chemical reactions which occur above the threshold or activation energy.

It is interesting to note in passing, that the history of nuclear reactions has been almost the converse of that of chemical kinetics. Interactions of accelerated, i.e. hot nuclei, have been intensively studied for the last forty years. On the other hand, thermonuclear processes have been experimentally difficult to realise, and as a result knowledge of the threshold processes in nuclear chemistry has only evolved slowly. The recent development of the chemistry of translationally hot species has been linked to two techniques. In the case of hot ion chemistry, mass-spectrometric methods of studying ion-molecule reactions have yielded some information on the velocity dependence of these processes (48).

Recent progress in hot atom chemistry has largely depended on the use of atoms produced by recoil processes in nuclear transformations. In fact the terms "hot-atom chemistry" and "chemical effects of nuclear transformations" are sometimes considered synonymous. This is not correct; nuclear recoil processes are considered simply as one possible technique which can be applied to the

problem of the mechanism of hot atom reactions. Conversely, the nuclear activation method can be used to investigate chemical processes other than hot atom reactions.

2.2 Techniques for the Production of Hot Atoms

A. Beam methods

The ideal way to study kinetic processes is to study individual collisions. This is equally true for hot and thermal processes. The best way of studying single collisions is to produce a beam of the species in question and let it interact with another reagent.

Unfortunately results from the use of beam methods involving single mono-energetic collisions are at this point a future hope rather than a present reality. Investigations have been made using a thermal beam to study certain reactions having zero or very low energy thresholds (49).

The methods by which hot processes have been studied all involve the production of a high energy atom which is allowed to undergo successive, energy-degrading collisions in the medium in which it is to react. There is thus a continuous energy distribution of hot collisions. The initial hot atom can be produced by some kind of high energy beam method, photochemically, or by the recoil associated with nuclear transformation.

B. Photochemical Methods:

If a diatomic molecule is dissociated by a light quantum having more energy than that of the bond, the atoms produced will be hot. This technique holds considerable promise for the production of higher-energy hot atoms, as produced by radiation in the far ultra-violet.

The main advantage of photochemically produced hot atoms is that their initial kinetic energy is accurately known. If the hot atom escapes combination on its initial collisions, it may still combine in low-energy collisions. Photochemical hot atom methods however have a serious limitation. The system should absorb the light only in that mode which leads to the production of hot atoms. If this is not the case, results may be ambiguous.

C. Nuclear recoil techniques:

The great majority of hot atom studies have been made by using nuclear recoil techniques. The basic method is to mix a substance which on nuclear transformation will yield the hot atom with the compounds with which the hot atom will react. The mixture should be homogeneous on the scale of the recoil range of the hot atom. Other substances may also be present in the mixture, notably scavengers to absorb those atoms reaching thermal energies without undergoing a hot reaction, and moderators to vary the energy spectrum of reactive collisions. The sample is exposed to the appropriate nuclear particles and a very small fraction of nuclei is transformed; the irradiation being sufficiently short so that there

is no appreciable macroscopic decomposition. The transformed nuclei are generally produced as high energy ions (up to 10^8 eV). They lose energy by collision and should become neutralized well before reaching the "chemical" energy range. They then continue to lose energy and may eventually undergo a collision in which they become chemically combined. If not, they will reach thermal energies and will react as thermal atoms. The products incorporating the hot atoms are then separated and assayed. This analysis makes use of the fact that the hot atoms, and hence the molecules containing them, are radioactive and the method is actually limited to radioactive species. This is because the number of hot atoms that can be produced without extensive radiation damage is so small that only the radioactivity can be used to detect the product molecules, and to distinguish them from the possibly much higher yields of similar molecules produced by the processes not involving hot reactions.

The recoil method is characterized by the continuous energy distribution of hot atoms available for reactions. This technique is therefore limited by the lack of direct control over the reaction energy. The recoil systems, being well defined, are susceptible to quantitative kinetic treatment. Furthermore the fact that hot atoms of essentially all energies are available makes the method appropriate for studies over the entire chemical energy range.

Some types of nuclear transformation, for instance isomeric transition and low-energy beta emission, are automatically excluded because they do not usually impart an appreciable recoil energy.

However there are processes, notably radiative neutron capture (n, γ), which provide a moderate recoil energy, quite sufficient for hot atom studies, but which involve a considerable risk that the species actually being studied are ionic. As will be discussed below, such a risk that the species actually reaching the hot reaction region is ionic is minimized if the actual recoil energy is much higher than the 1-20 eV needed to study the hot reaction. The hazard of such ambiguity also exists for hot atoms of higher mass even when they are produced by particle emission processes. An obvious limitation of the recoil method is that not all elements have radioisotopes of suitable half-life, which can be produced by particle emission processes.

Radiations associated with the nuclear recoil reaction can obscure the results of hot atom reactions in two ways:⁽⁵⁰⁾

- a) Sample decomposition and consequent introduction of impurities. This should not be a great problem since the probability of hot atom reaction on collision will generally not be different in magnitude for the reagent and the impurity molecules. Thus the effect of small amounts of impurities will not be nearly as serious as it is in most of the thermal systems.
- b) Decomposition and transformation of product molecules. If the product molecules are no more sensitive to the radiation energy and to the radiation produced species than are the parents of the reagent molecules, there is generally no problem.

Even if the total radiation that is absorbed by the sample amounts to 0.1 electron volts per molecule, the fraction of reagent and product molecules affected will rarely exceed 1 per cent.

This situation holds if the product molecules have a chemical reactivity which is very similar to that of the original reagent.

D. Charge and Excitation State of Hot Species:

When a hot species is produced at energies within or above the 1-100 electron volts range where it may be expected to react, its charge state on reaction will be determined by its initial charge and by the subsequent charge exchange collisions. In order that there may be reasonable certainty about what is actually being studied, these matters must be examined carefully when considering the production of hot atoms by recoil or high energy beam techniques.

There are three factors which determine the final state of a hot species:

- i) Its primary state as it is produced by the initial nuclear transformation and associated electronic processes. This subject has been reviewed by Wexler (51).
- ii) Charge exchange processes occurring while the species is recoiling. For the high recoil energy processes most useful in producing hot atoms this factor is dominant to the extent

that factor one (the primary state) is irrelevant to the final state.

- iii) The possibility of ionization occurring subsequent to recoil because of delayed nuclear processes. Most nuclear transformations which provide enough recoil energy to be potentially useful for hot atom studies are more or less likely to yield the species as ions (51). For species with a recoil energy in the KeV region or higher so many charge exchange collisions can take place before the species reaches the hot chemical reaction region, that the initial charge state is irrelevant (52).

The recoil energy of species produced by (n,γ) reactions is however only in the region of hundreds of electron volts (51) and this energy depends on the actual de-excitation cascade (53). Thus the final state of ionization may depend on the nature of the γ -rays emitted.

If there are low energy γ -rays, particularly due to forbidden transitions, ionization by internal conversion and Auger processes are likely. In the absence of information on the γ -cascades, there will thus be a considerable uncertainty about the charge state of hot species. Very high energy species produced by nuclear recoil behave like any other particular ionizing radiation. They will rapidly become ionized, losing all those electrons with velocities less than about the translational velocity. During this stage energy is lost by electronic collisions, leading to ionization and electronic excitation of the medium. As the velocity of the particle decreases to that of electrons in a given orbital - about 25 KeV

for a proton and correspondingly higher for the outer orbitals of heavier species - electron exchange collisions with the medium become sufficiently frequent to be a major mode of energy loss.

The equilibrium or average charge of the recoil species gradually decreases until it becomes neutral. Further, energy loss of the neutral species occurs by its collision with atoms as a whole. This leads to various types of excitation of the medium but only rarely to ionizing events.

2.3 Identification of Hot Processes

A. Definitions and Criteria for Hot Reactions:

The usual definition of hot processes is the rather negative one that they are not thermal processes. A thermal process is in turn defined as a reaction taking place in a system at or near the thermal equilibrium; this means that the kinetic energy of the reacting system is usually near the lowest activation energy or threshold.

The identification of an observed reaction as being hot must, therefore, rest on the determination that it does not have the usual properties of thermal or threshold processes. An examination of the difference in properties between the thermal and hot reactions leads to several experimental criteria for distinguishing them (50). Such distinction is unnecessary if one is using beam particles reacting at a single energy only. The usual type of experimental system involves high energy atoms which, if they do

not react while hot, cascade down to and then react at thermal energies. The fact that atoms are produced hot does not mean that they all react while they are still hot, and criteria for distinguishing between their hot and thermal reactions are necessary.

Thermal processes generally have a very low collision efficiency. On the other hand, hot atom reactions must occur in the few collisions suffered by the hot atom while it is in the appropriate energy region. Addition to the reaction mixture of a small amount of scavenger, capable of reacting with the thermalized hot atoms, may therefore control thermal reactions which might be mistaken for hot processes. The scavenger will not affect hot reactions since a hot atom will encounter it during the few collisions of its chemically effective existence.

An effective scavenger has a rate constant for reaction with the thermalized hot atoms which is sufficiently large that even in very small concentrations it will remove all of them. To make sure that a scavenger is efficient the dependence of the yields on scavenger concentrations should be investigated. Scavenger techniques have the advantage that they may scavenge the reactive products of hot reaction, and thus render them observable.

B. Condensed Systems: Cage Reactions

The distinction between hot and thermal or threshold processes is very much more difficult to make in condensed than in gaseous systems. In part this is due to the purely practical difficulty of finding soluble scavengers and moderators. A more fundamental diffi-

culty is presented by "cage" reactions which are absent in the gas phase. By a cage process is meant a reaction consisting of a collision in which the hot atom produces a radical, which is trapped by the solvent in the same "cage" as the atom, becomes thermalized by collision with the cage "walls" and then undergoes thermal combination with the radical (54). Such a process will be temperature independent and, since it involves only a few molecules, will not be affected by normal concentrations of scavengers. It is interesting to note that the cage-recombination models, rather than direct hot replacement, were long considered as the basis for theories of recoil atom combination in the condensed phase (54).

The borderline between "cage" and "true" hot combination reactions is difficult to establish not only experimentally but also in principle. In a "true" hot reaction the product is formed directly on impact within the time span of one vibration.

It is, however, conceivable that the product will be formed in an excited state and must be stabilized by an immediate collisional energy transfer to survive. Such a stabilization of an excited intermediate by the collisions with the cage walls, may not be distinguishable in any qualitative sense, from combination of a caged atom with a radical which it has just created. It is probably most convenient to regard cage reactions as hot reactions, whilst recognizing that caging effects may make possible certain modes of hot reaction in the condensed phase that are not possible in the gaseous phase.

These ambiguities are the usual difficulty one may encounter when one tries to resolve an interaction with a continuous medium into separate interactions with discrete units of that medium.

Detailed studies on recoil bromine from (n,γ) reactions in liquid systems have established that scavenger effects can provide a clear distinction between hot reactions and thermal or "diffusive" processes (41). It must be recognized that in hot atom chemistry, the condensed phase is much more difficult to treat. Cage effects make the phenomena occurring more complex in character, and to study them one must do without moderator techniques.

2.4 Theories of Hot Atom Reactions

In early work, there were grave doubts as to whether the reactions of tritium, for example, were hot atom reactions or just ionic or hot ion reactions. For many years Willard et al (27) maintained that tritium was reacting as an ionic species in nuclear recoil experiments. Hamill and Williams (28) studied hot atom reactions of hydrogen in ethane and deuterium, but although they observed the production of methane, they thought that this could be accounted for by impurity in their materials. They also felt that the chain lengthened products observed in recoil experiments resulted from ion molecule reactions. Estrup and Wolfgang (29) using I_2 and Br_2 as scavengers pointed out that if ion molecule reactions were responsible for the major products then they would expect such species as CH_4^+ to react rapidly with low ionization

potential scavengers. Early theories of hot atom reactions were developed primarily for solid and liquid phase reactions where cage effects may play an important role. Libby's billiard ball model and Willard's random fragmentation theory do not appear to be well suited to the gas phase reactions. In general, until about 1957 it was held that hot atoms produced radicals on collisions and, after deactivation, combined with one of the fragments (2). The idea of a cage effect was invoked to account for the high efficiency of the hot reactions. In 1958, however, these views were criticised by Estrup and Wolfgang (30) who presented evidence to show that only 1-2% radiation damage was induced into a hydrocarbon sample. They also showed that HT production from the walls of the reaction vessel was an idea which had about come to the end of its time when they demonstrated that HT diffusion from the walls of the reaction vessel was nil at 20°C and about 5% if the sample was heated to about 60°C.

The lack of effect on the yield of changes in time of irradiation, flux density, and the effect of scavengers and the yields of products in the liquid phase etc., led Estrup and Wolfgang to propose that a hot one-step reaction was responsible for the production of several substances which could undergo secondary, thermal reactions. The first mechanistic theory developed for the gas phase reactions was the steric theory presented by Wolfgang. This theory very simply suggested that there were two principal hot tritium reactions - substitution reactions and abstraction reactions. Wolfgang has refined the steric theory in order to account for the drop in substitution products of halo-methanes as the number and

size of the halogen substituents increases. Briefly he suggested that after collision with the side of a C-X bond, the displacement of a halogen atom, the remaining methyl radical must rotate to form a bond with the tritium atom. The suggestion is that if the radical has a high moment of inertia due to heavy substituents, rotation is slowed down and the amount of successful tritium capture decreases.

2.5 Hot Atom Reactions of Halogens

The systematic investigation of the chemical consequences of nuclear transformation largely dates back to the discovery of the Szilard-Chalmers effect in liquid ethyl iodide. It is thus not surprising that much of the early work on the reactions of hot species produced by nuclear recoil dealt with halogen interactions in the liquid phase. Many of the current ideas on hot atom reaction mechanisms in liquids derive from this work. In particular the importance of cage recombination was emphasized, both by Libby in his "billiard-ball" and "epithermal" reaction models and by Willard in his "random-fragmentation" hypothesis (54). Following the work of Willard on gas-phase systems, doubts arose as to whether recoil halogen resulting from the commonly used (n, γ) process were actually reacting as atoms or as ions (8). There is a place for such doubt in the case of species produced by low recoil energy reactions such as (n, γ). The aim of much of the present work on chemical processes involving halogens produced by chemical transformation, therefore concerns elucidation

of the nature and electronic history of the reacting entities. As such it does not fall within the narrow definition of hot atom chemistry used in this review. This field of chemical processes of halogens produced by nuclear transformations has been covered by a series of reviews by Willard (54).

A. Fluorine

The chemistry of recoil fluorine is most conveniently studied using the ^{18}F isotope, which has a half-life of 112 minutes. This isotope can be produced by irradiation of ^{19}F with fast neutrons, $^{19}\text{F}(n^*, 2n)^{18}\text{F}$ or by the $^{19}\text{F}(\gamma, n)^{18}\text{F}$. ^{18}F decays by positron emission and so is easily detected by the characteristic annihilation 0.51 MeV γ -rays. Counter design is therefore much easier than for tritium, 'window' flow-counters or scintillation counters can be used.

The chemical reactions of recoil fluorine have been studied with hydrocarbons and alkyl fluorides; both 'hot' and 'thermal' reactions can be distinguished. With the simplest paraffin, methane, methyl fluoride is formed but in low yield. Todd, Colebourne and Wolfgang (57) attempted to use the Estrup-Wolfgang method of data analysis to determine reactivity integrals so that a comparison could be made between $^{18}\text{F} + \text{CH}_4$, $^{18}\text{F} + \text{CH}_3 + \text{H}^{\cdot}$ and $^{18}\text{F} + \text{CF}_4$, $^{18}\text{F} + \text{CF}_3 + \text{F}^{\cdot}$ reactions. They found that $I(^{18}\text{F} + \text{CH}_3)$ was three times as great as $I(^{18}\text{F} + \text{CF}_3)$ but this result is of little value since the 'kinetic theory' requires that all hot products be taken into account in the analysis, and the yield of H^{18}F was not determined.

When recoil fluorine reacts with ethylene, (75) highly excited fluoroethylene is formed, which decomposes to methylene and labelled fluoromethylene. Recoil fluorine can react with cyclic hydrocarbons; (76) the

excited fluoro-compounds that are formed readily isomerize.

Recoil fluorine reacts readily with aromatic molecules such as fluorobenzene (77). 36% of the ^{18}F activity is found in the labelled parent molecule and 10% in difluorobenzene. Reactions with toluene have also been studied (78). In perfluorobenzene-hydrocarbon mixtures attempts have been made (79) to relate the percentage of ^{18}F entering inorganic combinations to the ratio of hydrogen to fluorine atoms in the substrate. The reactions of recoil fluorine with perfluoro-compounds have also been observed. With perfluoromethane (80), the compounds $^{18}\text{FCF}_3$, $^{18}\text{FCF}_2$, and ^{18}FCF were detected.

Recoil fluorine is so reactive when 'hot' that possible reactions of cool or even thermal atoms are all but obscured. Rowland and his co-workers have overcome this difficulty by working with an excess of a moderator such as sulphur hexafluoride or carbon tetrafluoride. It is found that 'cool' fluorine atoms add readily to the double bond in ethylene (81), and in other unsaturated compounds.

B. Chlorine

Recoil chlorine atoms are most easily produced by irradiation of stable chlorine with thermal neutrons, $^{35}\text{Cl}(n, \gamma)^{36}\text{Cl}$ and $^{37}\text{Cl}(n, \gamma)^{38}\text{Cl}$, but the former has such a long half-life that it is of no practical use. The half-life of ^{38}Cl is about 30 minutes, which makes it a very convenient isotope. Since however, it is produced in an (n, γ) reaction its recoil energy is very low and not well defined, an average of about 500 eV. Furthermore, the atoms will be produced in an ionized and electronically excited state. The number of collisions which the atom will undergo before

it reaches 'chemical-energies' (i.e. a few eV) will be limited so that it might well react as an ion or as an electronically excited species. Recoil chlorine atoms can also be produced in other nuclear reactions with much greater recoil energies, $^{35}\text{Cl}(\gamma, n)^{34\text{m}}\text{Cl}$ and $^{40}\text{Ar}(\gamma, p)^{39}\text{Cl}$. Both of these isotopes have convenient half-lives and, because of their origins, will stand a much greater chance of eventually reacting as neutral, ground-state atoms. A comparison (82) of yields of chlorine-labelled species induced by the (n, γ) and other reactions has shown no differences - suggesting that even from the (n, γ) reaction the chlorine does react as a ground-state atom. Being heavier than fluorine it is to be expected that 'hot' reactions of chlorine will give rise to considerable vibrational excitation. The yields of stable labelled products are therefore expected to be even less than for fluorine. The C-H bonds are quite useful scavengers for thermal chlorine atoms, so that reactions in hydrocarbon and alkyl systems should be exclusively due to 'hot' atoms.

In the liquid phase the reaction of recoil chlorine with hydrocarbons gives rise to much higher yield of labelled products (83,84). The increase in yield is most simply ascribed to the ease with which excitation energy can be dissipated in the liquid, and also to the 'cage' effect which promotes radical recombination reactions.

In the liquid phase the total yield of labelled organic products increases to about 20% of the total available chlorine activity. The labelled parent molecule is usually the largest single component but a very wide range of other compounds is also formed. It is interesting to note that n- and iso-propyl chlorides do not isomerize

(85) in their reactions with recoil chlorine, which affords support for the idea that recoil chlorine reacts as an atom and not an ion.

C. Bromine

Recoil bromine species can easily be produced by thermal neutron irradiation of bromine itself. As in the case of recoil fluorine and chlorine, greatly increased yields of labelled organic molecules are observed in the liquid phase, by comparison with the gas phase. By contrast with the gas phase it is found that yields from the (I.T) processes exceed those from the (n, γ) reactions. In the presence of 5 mole% of bromine the various isomers of hexane gave organic yields of (I.T) 20-25% but of (n, γ) only 15% (86). The simple neutron irradiation of alkyl bromides gives rise to organic yields of about 35%, which can be reduced to about 20% by the addition of 1-2 mole % of bromine. A comparison of (n, γ) and (I.T) activation has been made using ethyl bromide by comparing the products from the $^{81}\text{Br}(n, 2n)^{80\text{m}}\text{Br}$ and $^{82\text{m}}\text{Br}(\text{I.T})^{82\text{g}}\text{Br}$ reactions. Little difference was found, (87) in contrast to the gas-phase result and also results from hydrocarbon systems. A detailed investigation of the chemistry of (I.T) $^{80\text{g}}\text{Br}$ in alkyl halide systems has failed to reveal (88) any differences that could be ascribed to the original partner of the recoil atom. The reactions of various bromine species in carbon tetrachloride have produced some unique conclusions. It would appear (89) that 'hot' bromine atoms do not react with carbon tetrachloride and that the reactions which are

observed are due to the formation of charged species in (I.T) processes; it is also necessary to assume, however, that charging does not result from ^{82m}Br (I.T) ^{80g}Br .

Whilst much uncertainty exists about the actual reactivities of the various bromine species and the effects which molecular environments may have, there are other types of mechanistic study which can be carried out. These deal with the addition of various amounts of scavengers to the systems being studied in an attempt to determine which products might be formed by true 'hot' reactions, which might be formed very quickly after the recoil atoms have come to rest (cage reactions), and which might involve thermalized recoil atoms freely diffusing through the bulk of the liquid. Small amounts of additives will clearly affect these later reactions. The addition of small amounts of bromine to n-propyl bromide and isopropyl bromide systems showed (90) that one reaction of a diffusing bromine atom was to produce labelled parent compound. It was found that about 40% of recoil bromine atoms did react whilst thermally diffusing through the liquid, and it was also found that 1,2 dibromo-ethylene was effective at much lower concentrations than bromine, showing that the labelled bromine atoms which are to end up in inorganic combination have much longer diffusion paths than those which are destined to form organic molecules. Shaw and various co-workers (90,91) have made a thorough and detailed investigation of the reactions of activated bromine species with ethyl bromide. The role of diffusion-controlled reactions has been investigated and the possibility of different chemical reactions being associated with (n, γ)- ^{80m}Br and (I.T) ^{82g}Br studied. Aromatic

systems react with recoil and with (I.T) activated bromine, the latter giving the higher organic yield (26%) with benzene [(n, γ) 18%] (93). The reactions of (I.T)^{82g}Br with dibromo- and chlorobromo-benzenes have also been studied (94). Competitive experiments (95) also using (I.T)^{82g}Br with benzene and nitrobenzene, toluene, etc. showed reduced reactivities for the substituted benzenes. Stamouli and Katzanos (95) showed that the total organic yields from the reaction of (I.T)^{82g}Br with a series of C₆H₅X compounds could be correlated with the C-X bond strength. In chloro- and fluoro-benzenes some preference for ortho- and para-substitution is observed (97) whilst naphthalene has been shown to be more reactive than benzene. These results do not give a clear picture but do suggest that positive bromine ions might well be playing an important role in the chemistry of (I.T) activated species with aromatic molecules.

D. Iodine

Recoil iodine is most easily made by the reaction of thermal neutrons with iodine, ¹²⁷I(n, γ)¹²⁸I, but this reaction suffers from the problems of interpretation that are bound to accompany a species of low recoil energy. It is also thought probable that ¹²⁸I is not formed in its nuclear ground state but might well enter chemical combination at the end of its recoil track before undergoing its final relaxation to ^{128g}I. As in the case of bromine, the existence of such excited states with nano- or micro-second half-lives severely complicates an understanding of the fundamental reaction processes. There is, however, a variety of nuclear reac-

tions which can produce other recoil isotopes, some with high recoil energy, e.g. $^{129}\text{I}(n^*, 2n)^{128}\text{I}$, and other reactions which enable (I.T) processes to be examined in isolation, e.g. $^{130\text{m}}\text{I}(\text{I.T})^{130\text{g}}\text{I}$. A comparison of results from a variety of different recoil isotopes should therefore give insight into the fundamental reaction processes. As in the case of chlorine and bromine, a change of phase brings about a considerable change in the fraction of recoil activity entering organic combination; gas- and liquid-phase results will therefore be considered. In the gas phase, recoil iodine $^{127}\text{I}(n,\gamma)^{128}\text{I}$ reacts with methane to give (98) an organic yield of 54%. This remarkable result was shown (99) by the addition of moderators and additives with particular ionization potentials, to be due to a variety of iodine species.

In liquid phase organic yields of 40-50% are found when dilute iodine solutions of pentane or decane are subjected to neutron irradiation (100). If the iodine concentration reaches 0.5% the yield falls by about 10%. The contrast with the corresponding vapours is dramatic. It is interesting to note, however, that at very high gas densities the organic yield from ethane increases, suggesting a smooth trend of increasing organic yield in going from vapour to liquid. The difference in total yield is also reflected in the pattern of labelled products that is found; in liquid butane (101) a 26% of yield of labelled n-butyl iodide is observed, a product which is completely absent in the gas phase. This in turn suggests that perhaps excited butyl iodide is a primary product, which decomposes in the gas phase but which is rapidly stabilized by collision in the liquid. The γ -radiolysis of pentane solutions

of alkyl iodides containing labelled iodine ($^{131}\text{I.I}$) gives a very similar distribution of labelled products (labelled with ^{131}I). This result presents a very strong case for the chemistry of 'recoil iodine' being in fact the chemistry of iodine species, probably charged, that are produced by internal conversion of an isomeric transition taking place in the iodine nucleus at the end of its recoil track.

The nature of the chemical reactions that follow neutron irradiation of alkyl iodides has been studied since the first experiment of Szilard and Chalmers with ethyl iodide. Tracer amounts of iodine have specific effects upon certain labelled products and γ -rays does also affect the observed organic yield. A general mechanistic conclusion on the reactions of recoil iodine in alkyl halides is not possible but it would seem, once spurious effects due to trace impurities have been eliminated, that, exchange processes between alkyl iodides and inorganic iodine compounds, as well as autoradiolysis effects are important in determining the final yields of labelled products.

CHAPTER 3EXPERIMENTAL

The procedure outlined below was adopted for the experimental work throughout this project:

Materials → Purification of materials →
Sample preparation → Sample irradiation →
→ Extraction → Separation → Counting
of activity. →

Each section of the above outline is discussed in detail below.

3.1 Materials

Most of the reagents (listed below) were analytical grade. Some of the organic compounds were tested on GLC and found to be of adequate purity. Other organic compounds were purified in the laboratory, and the remainder (of high stated purity) were used without further purification. All the materials used in this work are listed below under the name of the supplier.

i) Koch-Light Laboratory Limited.

o - iodotoluene

m - iodotoluene

p - iodotoluene

Ethyl iodide

Methyl iodide

Iodobenzene

O - iodobiphenyl

m - iodobiphenyl

p - iodobiphenyl

Fluorobenzene

Hexafluorobenzene

o - bromotoluene

n - bromotoluene

ii) Eastman Organic Chemicals.

o - diiodobenzene

m - diiodobenzene

p - diiodobenzene

iii) Fisons Scientific Apparatus Limited.

Bromine

Methanol

Ethanol

n - Butanol

Cyclohexane

Sodium sulphate

Carbon tetrachloride

Diethyl ether

Pyridine

3.2 Purification of Materials

Koch-Light iodotoluenes were used without further purification.

GLC analysis showed the purity to be greater than 98% for the ortho- and meta-iodotoluenes and greater or equal to 99% for para-iodotoluene.

Fisons reagent grade Iodine with a stated purity of 99.5% was used as a scavenger without further purification.

Koch-Light ortho, and para-iodobiphenyl with a stated purity of 98% (GLC) were used without further purification. Koch-Light iodobenzene with a stated purity of 99% (GLC); and Fisons ethyl iodide and methyl iodide were used as standards. The exposure of these compounds to light leads to a rapid decomposition, with the liberation of free iodine. To purify these compounds, the following procedure was used;

1. The compounds was washed four times with dilute aqueous $\text{Na}_2\text{S}_2\text{O}_3$ solution.

2. Washed four times with distilled water.
3. Dried with molecular sieve type 5A.
4. Distilled under reduced pressure.

The pure samples were stored in dark bottles to prevent their photolytic decomposition. All other compounds and materials were used without further purifications.

3.3 Production of Radioactive Isotopes by Neutron Irradiation

Throughout this project, radioactive isotopes of iodine and bromine were prepared by irradiation of iodo and bromo aromatic compounds with neutrons generated from a Kaman Nuclear Generator (type A - 1003). As the production of a suitable neutron flux is fundamental to the success of this project, suitable neutron sources are described below:

1. The use of a small laboratory neutron source. The most common laboratory sources are antimony/beryllium or radium/beryllium neutron sources which rely on γ, n reaction on beryllium to produce neutrons. Other sources such as Americium-241/beryllium or the spontaneous fission neutron source Californium 252 (the average neutron energy $\sim 2\text{MeV}$) may also be used.
2. In this work, the only neutron source available was the neutron generator which produces fast neutrons at energies of $14.7 \pm 0.3 \text{ MeV}$ by the nuclear reaction: ${}^3_1\text{H} (d,n) {}^4_2\text{He}$.

3.4 Neutron Generator

The neutron generator is basically a positive ion accelerator. It accelerates a deuteron (${}^2_1\text{H}$) beam (typically up to 2 milli-amps),

through a potential difference of up to 200 kV. The deuteron beam strikes a target containing tritium (${}^3_1\text{H}$). The following thermonuclear reaction takes place in the target:



The reaction can be written as $\text{T}(d,n){}^4\text{He}$ in the usual shorthand notation. The cross-section for the reaction is high - about 5 barns at a deuteron energy of 110 KeV.

The neutrons produced are almost monoenergetic 14.7 ± 0.3 MeV, and are emitted isotropically from the target. The neutron energy is insensitive to the angle of emission, because of the high Q of the reaction. The neutron generator, Kaman Nuclear Model 1003, used in this work is capable of producing 10^{11} neutrons per second, giving a neutron flux of 2×10^9 n. cm⁻². sec⁻¹ at a sample position directly behind the target. Under the operating conditions used in this work a flux of 5×10^8 n.cm⁻². sec⁻¹ was generally available. The generator consisted of three basic components: the positive-ion accelerator and a vacuum pump, a 200 kV power supply, and a control console.

3.4.1 The Positive Ion Accelerator

A schematic diagram of the generator is shown in Figure 1. Deuterium gas is admitted into the ion source through a heated palladium leak. The ion source is of the Penning Ion Gauge (PIG) type, with a cylindrical anode and cathodes at each end, enclosed in a glass envelope called the ion bottle, (Figure 2). Electrons, created within the gas or at one of the cathodes, are attracted towards the anode by the electric field but are prevented from reaching it by the magnetic field. The magnetic field confines the

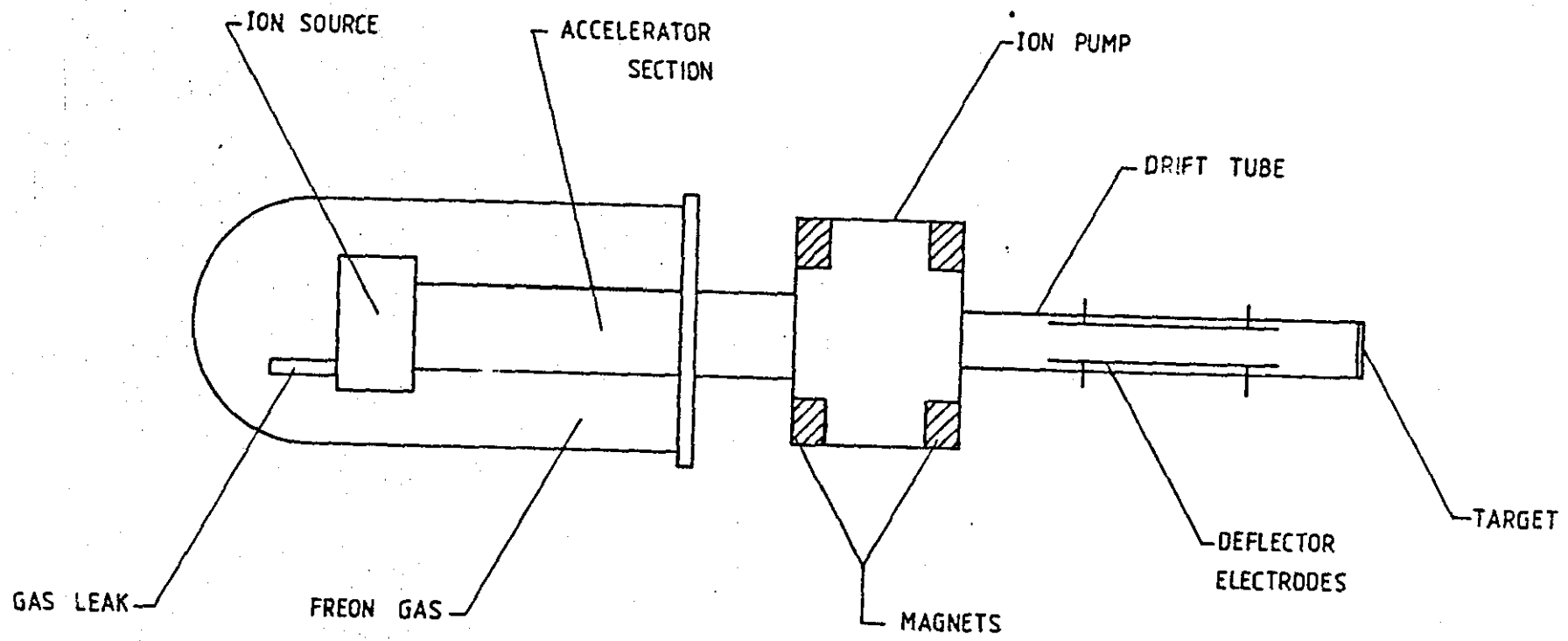
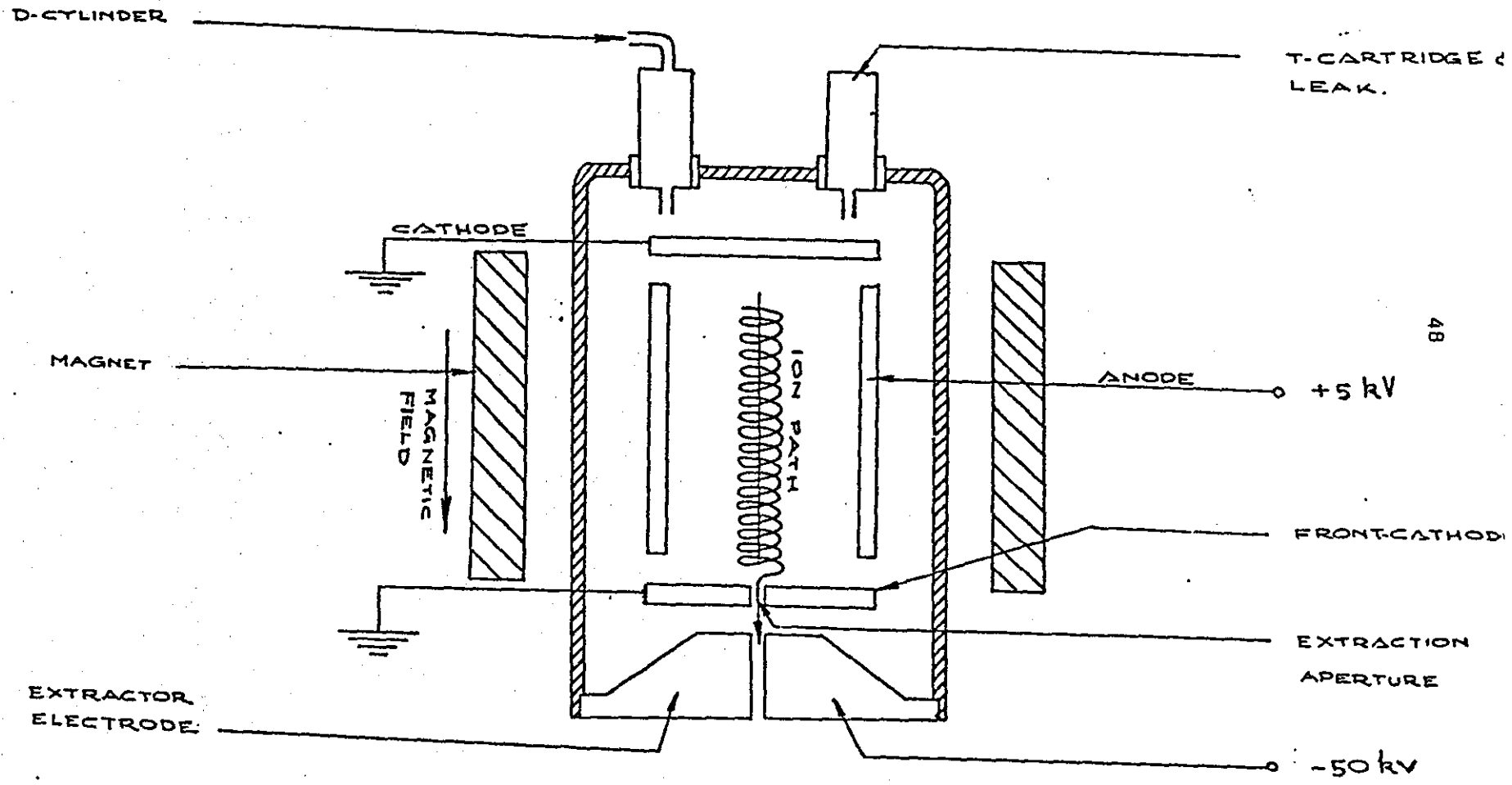

FIG 1 SCHEMATIC DIAGRAM OF GENERATOR



48

FIG-2 P.I.G ION SOURCE

electrons to a spiral path, in the central region of the ion bottle where they cause intense ionization. An extraction aperture is provided in the centre of the front cathode, through which ions are extracted by the application of a negative voltage (up to 50 kV) to the extractor electrode, placed close to the aperture. The hole in the cathode is small (about 0.07 in diameter) so that a good vacuum (about 0.01 micron) can be maintained in the accelerator whilst the ion source gas is at a higher pressure (1 micron).

The ions pass through a hole in its centre, the size of the hole is approximately the same as that of the exit aperture of the ion source. The extractor electrode is at a potential of 150 kV with respect to the ground. The cathode of the ion source is up to 50 kV above this potential. The extractor electrode, an intermediate electrode (at +75 kV) and a ground electrode from the accelerator column. The electrodes are mounted on a thick glass tube which acts as an insulator as well as a beam containment vessel. The voltage across the gaps between these electrodes accelerates the ions and focusses the beam to an appropriate size on the target. The palladium leak, ion source, and the accelerator column are enclosed in a stainless steel dome at earth potential. The dome is pressurized to 30 psig by 'Freon' gas, to prevent flash over from the high voltage terminals to the dome. This dome is essentially a safety device as it prevents accidental touching of the high voltage points. A pressure interlock prevents the application of power to the generator should the dome pressure fall below 30 psi.

A high vacuum pump, of the sputter ion type (usually called ion pump), is located between the accelerator column and the drift tube. It has a pumping speed of 140 litres per second and maintains the ion source, accelerating column, drift tube and the target at a

pressure of about 10^{-8} torr, to minimise scattering of the ion beam. The principles of operation of the ion pump are described in the literature (62). The current drawn by the pump is proportional to the pressure of the gas it pumps and this current is monitored on the control console. The accelerated ions pass through a field free region in the drift tube before they strike the target. Two deflector plates are mounted in the drift tube. A voltage of 2.5 kV is applied to the deflector plates to deflect the ion beam and hence reduce the production of the neutrons when not required. A stainless steel, high vacuum valve (called target isolation valve) is also mounted in the upper end of the drift tube. It isolates the drift tube from the rest of the system. In target changing only the vacuum of the drift tube is destroyed. The drift tube can be evacuated by a roughing pump through a valve provided and then the ion pump can take over by opening the target isolation valve.

Target

A rotating target type RTH2C (Figure 3) is made of a 1.5 inch annulus and of 6 inch o.d. and 0.10 inch thick copper foil, on which a $2.0 \text{ mgm}\cdot\text{cm}^{-2}$ layer of titanium is deposited. The titanium layer is impregnated with tritium by heating the foil, in tritium atmosphere, to temperatures of over 400°C , and gradually cooling in the same atmosphere. The target contains about 80 Curies of tritium. The ion beam dissipated about 150 watts of power in the target and forced circulation of water through a jacket at the back of the target keeps its temperature below 250°C , thus preventing the loss of tritium from the target. To prevent accidental damage to the target by the failure of the water flow, a coolant flow

DEMOUNTABLE TARGET DISC
 SERIES RTH2 - Max. Dia. 6 inch (152 mm)
 MODEL RTH.2C
 SCALE: FULL SIZE

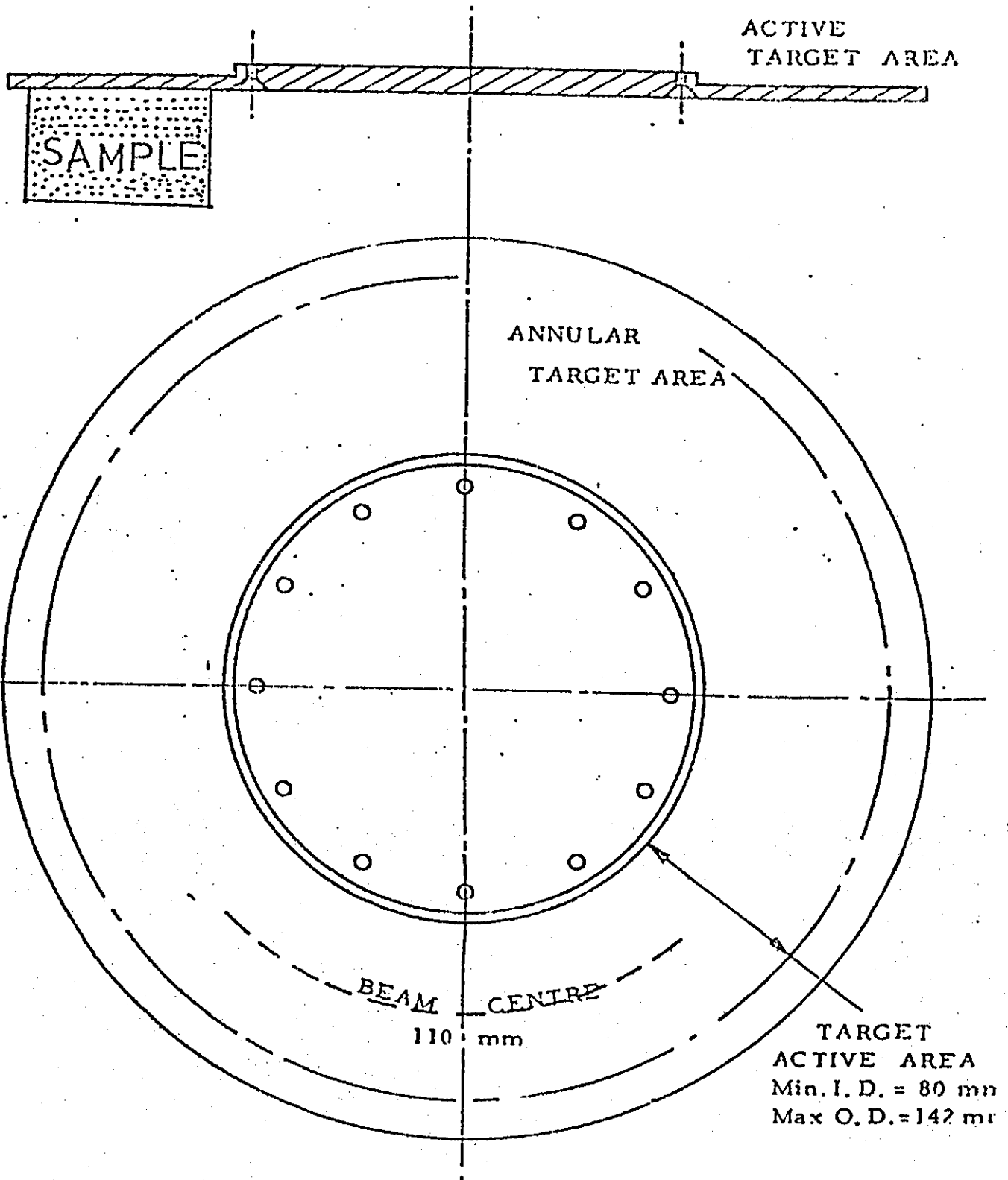

Fig. 3 An illustration of the target disc.

interlock is incorporated, which will shut down the generator. The tritium content of the target is halved after 100 hours of use. This is due to its utilization in the neutron producing nuclear reactions, its substitution by deuterium from the ion beam and its loss by evaporation from the target. The decrease of tritium concentration in turn decreases the neutron yield of the generator.

3.4.2 Power Supply

The accelerating voltage is supplied by a Cockcroft-Walton power supply. The mains voltage is boosted in 75 kV by transformer action and further doubled by a rectifier-condenser doubler circuit. The high voltage transformers, condensers and resistors are all immersed in two oil filled tanks, 24" x 24" x 28" high. A further safety measure is provided on the control console, which controls the high voltage generated, by varying the voltage applied to the transformer primary winding. Microswitches are provided in the variacs and do not allow power to be applied to the transformers unless the wipers are in the zero position. Both high voltage tanks are supplied with a gravity drop solenoid shorting bar which grounds the high voltage output when the power supply is switched off.

3.4.3 Control Console

The neutron generator, because of the radiation hazards, must be operated by remote control. The source, accelerator, extractor and leak voltages are also monitored at the console and protective cut-outs for the various power supplies are located here. Beam and target currents are indicated on the console. An irradiation

timer is also mounted on the console. This timer may be switched on by the sample delivery system as soon as the sample reaches the irradiation position. At that instant the voltage is removed from the deflector plates, allowing the deuterium beam to strike the target and generate neutrons. At the end of the irradiation time, preset on the timer, the deuterium beam is deflected, neutron production ceases, and the transfer system is actuated to suck back the sample to the counting position. Finally, the console has indicator lights corresponding to each interlock. When the interlock is functioning correctly, its light glows. In case of a faulty operating condition, the respective light goes off indicating the source of the fault.

3.4.4 Shielding

The generator is capable of producing 10^{11} n.s⁻¹. A neutron flux of 10 n.cm⁻².s⁻¹ is the permissible dosage for the 14.3 MeV neutrons, therefore the neutron flux must be reduced to permissible levels by shielding the generator. The room housing the generator measured 11' x 11'. It was fitted with high density concrete slabs along three walls of the room. The thickness of the shielding was 4.5 feet, in addition to the usual wall thickness. This leaves a hole of only two feet square and therefore the generator was mounted vertically. As a result, the target is 1.5 feet above the floor of the room. The concrete block filling reached a height of 7 feet. Two mobile tanks, 3' x 3'3" x 7' high, filled with water, and mounted on rails, provided a part of the shielding on the fourth side of the room. A wall of concrete blocks of 1' 3" thick, on the outside of the tanks completed the shielding. Removal of this mobile shield provided an access to the neutron generator for servicing processes.

K.G. Darral and G. Oldham (63), kept the neutron leakage to a minimum by keeping the bottom of the tanks only 0.25 inch above floor level and having the same clearance along the two side walls, between which the tanks move. The shielding was found to be adequate. Solid boric acid was poured into the small gap between the concrete and the walls to prevent leakage of thermal neutrons. One micro-switch is mounted over each of the two tanks. These do not allow the power to be applied to the generator if one or both tanks are removed.

3.4.5 Setting up Procedure of the Neutron Generator

The generator is started by turning the 'mains power' key switch. The cooling water and the 'Freon' pump are then switched on. The deuterium cylinder valve is opened to admit deuterium into the deuterium leak. All the interlock lights should be on at this stage. The deuterium leak is switched on and its temperature is gradually raised, by depressing the 'leak vernier' switch, in steps till the ion pump current meter reads 7.5-8 milliamperes, instead of the usual 10 microamperes in static condition. The leak vernier meter normally reads 40 volts at this stage. The ion pump current is a measure of the quantity of deuterium in the ion source. The start button is pressed. It will be held in the pressed condition if all the interlocks are working properly, and the start light will come on. The generator is now ready for application of power. The 'extractor voltage adjust' variac is then turned fully clockwise, to ensure that a broad beam hits the target. The target can be burnt if too narrow a beam hits it and causes local heating. Next the 'accelerator voltage adjust' variac is turned clockwise till the 'accelerator voltage' meter reads 100 kV. Finally, the 'source

voltage' variac is adjusted to give the peak beam current as indicated by the 'beam current' meter. The ion pump current is now checked and if any adjustment is necessary to bring it to 7.5 milliamperes, it is done by the 'leak vernier' switch. The accelerator voltage is raised to the desired acceleration voltage (usually 150 kV). The source voltage is adjusted for maximum beam current. Further optimisation of the beam current (it should be 1.5 - 2.0 milliamperes) is done by the 'extractor voltage' variac. The variac is then turned through 10 divisions on its scale to defocus the beam. The generator is now ready to deliver neutrons as soon as the voltage from the deflector plates is removed, by depressing the 'neutron manual' button or through the 'irradiation timer'.

3.5 Sample Transfer System

The sample is transferred through the shield to the generator and back to the counting position by a pneumatic transfer system. The transfer each way is accomplished in 1 to 1.5 seconds. The short transfer time is desirable for the study of activation products with short half-life. The transfer tube is of reinforced nylon, 1.25 in internal diameter, usually used in vacuum cleaners; it has a smooth uniform bore and can be bent into a curve of radius 1.5 feet without appreciable pinching or distortion. The transfer tube is fed through the concrete shield into the generator cavity through a 2.25 in diameter pipe. The tube emerges from the concrete at floor level and is bent into a 1.5 feet radius quadrant and inserted into a machined nylon end piece, rigidly clamped under the target. The bore of the nylon end piece is 0.031 in more than the outer diameter of the sample bottle, this ensures good reproducibility in the irradiation position. A thin steel annulus, screwed to the nylon end piece,

stops the sample. The sample is blown and held vertically under the target by air pressure. The source of air is a Secomack Statair blower model 37 (0.25 HP). The blower provides sufficient air to build up air pressure that will hold samples of over 50 grams weight in the irradiation position. At the end of the irradiation the direction of air flow is reversed by a solenoid operated valve, this sucks the sample from the irradiation position and brings it to the counting position. To achieve maximum counting efficiency, the sample bottle is inverted so that it falls on the crystal, with the sample container face downwards. This is accomplished as shown in Figure 4 . The sample is blown past the hole in the horizontal brass tube by its inertia, strikes the brass bars, bounces back and falls into the inclined tube and lands in the counting position with the right face down. The floor of the counting receptacle is sloping. The slope is such that the sample will slide upon it until it comes in contact with the vertical walls. This arrangement ensures reproducible positioning at the counting end. The floor of the counting receptacle is 0.028 in brass, which absorbs beta-particles without significant attenuation of gamma photons. The scintillation crystal is located directly below it. The transfer, the irradiation and the counting system is completely automatic. The sample bottle is placed in the horizontal brass tube, Figure 4 , and the hole is covered by a leak-proof rubber lined sleeve. The start button is pressed, this starts the blower, resets the neutron counter and starts an audible alarm. When the sample arrives at the irradiation position it breaks a light beam falling on a phototransistor unit. This actuates a relay circuit, which starts the neutron generation and starts the neutron monitoring counter system. At the end of the preset irradiation time, the timer terminates neutron generation and switches off the neutron flux monitor and the alarm. At the same time it actuates the solenoid

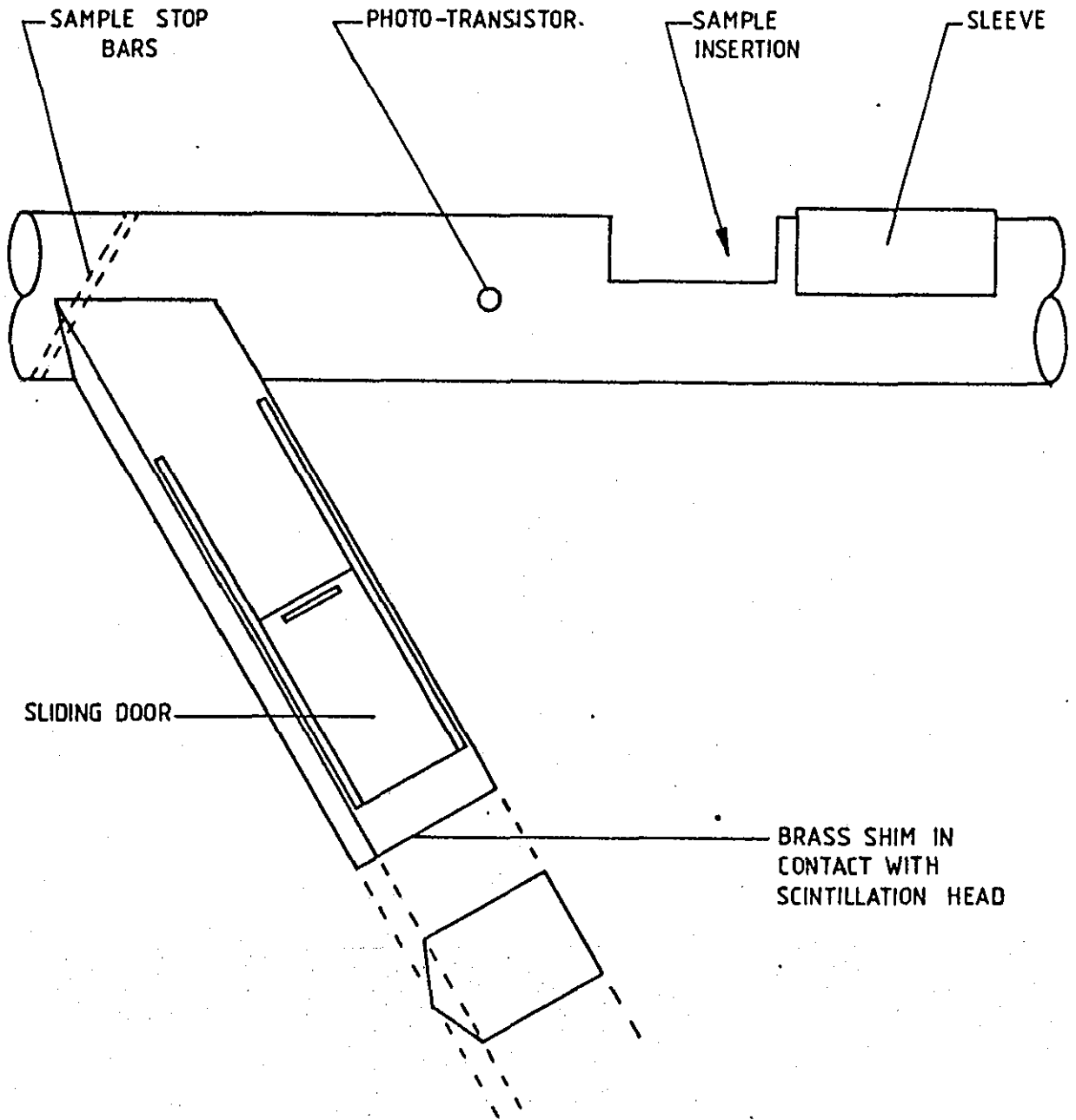

FIG 4 SAMPLE INSERTION AND REVERSAL SYSTEM

valve which reverses the direction of air flow, to suck back the sample and activates a delay relay. The delay relay starts the spectrometer counting 4 seconds after the end of the irradiation. Though the sample transfer time is only 1.5 seconds, the 4 seconds delay is introduced to correct the sample position in case it lands with the wrong face down. The returning sample intercepts a second photo-transistor light beam (near the counting end unit 1). This activates a relay circuit which switches off the blower, and switches over the recorder from the neutron measuring ratemeter to the logarithmic ratemeter monitoring the activity of the sample.

Fault lights and relay sequence lights are provided on a panel. These enable a rapid diagnosis to be made of any fault condition. As an example, if the sample bottle does not reach the irradiation position within 7 seconds a red fault light comes on.

3.6 Neutron Irradiation of Sample Compounds

Polyethylene vials of 1 ml volume containing the required volumes of iodotoluenes or the bromotoluenes, with or without degassing (degassing did not have any significant effect on the observed results), were placed at the irradiation position of the generator and irradiated for one minute unless otherwise stated in the experimental chapter.

Iodine-127 reacts with thermal neutron; therefore a piece of wax (12 cm) thick was placed between the target and the halotoluene to thermalize the fast neutrons. There are twenty-four radioactive isotopes of iodine. These isotopes and their decay modes are listed in Table 1. The known isotopes of bromine and their decay modes are given in Table 2.

TABLE 1
Isotopes of Iodine

Isotopes	$t_{\frac{1}{2}}$	Mode of Decay	Major radiations of Energies (MeV)
117	7m	β^+ [EC]	
118	13.9m	β^+ , EC	X-rays, γ .511, .55, .6, 1.15
119	19.5m	β^+ , EC	X-rays, γ .511, .78
120	1.35h	EC, β^+	β^+ , X-rays, γ , .511, .56, .62, 1.52
121	2.12h	EC, β^+	β^+ , X-rays, γ .212, .27, .32, .511
122	3.5m	β^+ [EC]	β^+ , X-rays, γ , .511, .564, .69, .78
123	13.3h	EC (No β^+)	X-rays, γ 0.159 (83%), e^- 0.127
124	4.15d	EC, β^+	β^+ , X-rays, γ , .511, .605, .644, .73, etc.
125	60.2d	EC (No. β^+)	X-rays, γ , 0.035 (7%), e^- 0.004, 0.03
126	12.8d	EC, β^- , β^+	β^- , β^+ , X-rays, γ , .386, .667
127	Stable	-	-
128	24.99m	β^- , EC	β^- , X-rays, γ , .441, .528, .743, .969
129	1.7×10^7 Y	β^-	β^- , X-rays, γ , 0.04(9%), e^- 0.005, 0.03
130	12.3h	β^-	β^- , γ 0.419, 0.538, 0.669, 0.743, 1.15
131	8.05d	β^-	β^- , X-rays, γ , .08, .364(82%) 0.284, .637, .723
132	2.26h	β^-	β^- , γ , .24, .52, .67 (144%), .77 (89%)

/Continued

TABLE 1 (continued)

Isotopes	$t_{\frac{1}{2}}$	Mode of Decay	Major radiations of Energies (MeV)
133	20.3h	β^-	β^- , γ , 0.53 (90%)
134	52.0m	β^-	β^- , γ , (many; .135-1.79)
135	6.68h	β^-	β^- , γ , (many; 0.20-3.2)
137	22s	β^-	n
138	5.9s	β^-	-
139	2.7s	β^-	-

TABLE 2
Isotopes of Bromine

Isotopes	$t_{1/2}$	Mode of Decay	Major radiations of Energies (MeV)
74	36m	β^+ , EC	β^+ (4.7), γ 0.511, 0.64
75	1.7h	β^+ , EC	β^+ (1.7), γ 0.285, 0.511
76	16.1h	β^+ , EC	β^+ (3.6), γ 0.511, 0.559, 0.65, 0.75, 0.85 etc.
77	57h	EC, β^+	β^+ (0.34), γ 0.24, 0.30, 0.52, 0.58, 0.75
77m	4.2m	IT	γ 0.108, e^- 0.094, 0.106
78	6.5m	β^+ , EC	β^+ (2.55), γ 0.511, 0.614
79	Stable	-	-
79m	4.8s	IT	γ .021
80	17.6m	β^- , β^+ , EC	β^- (2.0), β^+ (0.87), γ 0.511, 0.618, 0.666
80m	4.38h	IT	γ 0.037, e^- 0.024, 0.036, 0.047
81	Stable	-	-
82	35.34h	β^-	β^- (0.444), γ 0.554, 0.619, 0.698, 0.777, etc.
82m	6.05m	IT	γ 0.046, 0.777, 1.475, β^- , e^-
83	2.41h	β^-	β^- (0.93), γ 0.530
84	31.8m	β^-	β^- (4.68), γ 0.81, 0.88, 1.01, 1.21, 1.90 etc
85	3.0m	β^-	β^- (2.5)
86	54s	β^-	β^- (7.1) γ 1.29, 1.36 etc
87	55.6s	β^- , n	β^- (8.0), (2.6), n 0.3, γ 1.44, 1.85 etc.

/Continued

TABLE 2 (Continued)

Isotopes	$t_{\frac{1}{2}}$	Mode of Decay	Major radiations of Energies (MeV)
88	15.5s	β^- , n	γ (0.76)
89	4.5s	β^- , n	n (0.5)
90	1.6s	n	-

3.7 Analysis

The analysis procedure included the following:

- i) Extraction procedure
- ii) Separation and identification of the radioactive products
- iii) Determination of activity.

3.7.1 Extraction Procedure

Liquids are usually irradiated in enclosed capsules of quartz or glass. In this work a polyethylene bottle of 1.0 ml volume was used. After irradiation the bottles were opened and the contents discharged into a separating funnel containing 5 ml of aqueous sodium sulphite solution (0.1N). The distribution of radioactivity between the two layers was then determined and the result expressed as the percentage "organic yield" (Y),

$$Y\% = \frac{\text{activity in organic solution}}{\text{activity in organic and inorganic}} \times 100$$

The amount of radioactivity present in each solution is usually measured with a scintillator counter which is described in Section 3.

Decay corrections were applied to the data and the equation used for the corrections of the decay time is:

$$\% \text{ Remaining activity} = \frac{1}{2^{B/A}} \times 100$$

where: A = half-life

B = decay time

3.7.2 Gas-Liquid Chromatography

To separate and to identify the various labelled compounds after irradiation, gas-liquid chromatography (GLC) was used because it is applicable not only to a wider range of solutes, but also to both packed and capillary columns. When a sample containing a mixture of components is injected into the moving stream, the components move through the column at rates dependent on their respective volatilities and interaction with the non-volatile stationary phase. With a stationary phase possessing suitable properties and a column of sufficient length, the partition process between the gas and liquid phases results in a situation in which each component of the sample emerges at different times from the end of the column as a binary mixture with the carrier gas. In gas-liquid chromatography the retention values are a means for qualitative identification of the unknown components, either by calibration with known materials or comparison with relative values from the literature. In addition to indicating the minimum number of components present and providing qualitative information from retention times, quantitative data giving the amount of each component are obtained from peak area measurements and calibration of the detector. All gas-liquid chromatography analyses have been carried out with Aerograph-Autoprep Model A-700 using a thermal conductivity detector. This unit (Figure 5, Figure 6) is a modified Aerograph A-90P featuring:

- a) A low mass - low inertia heater for rapid heating and cooling of the column.

- b) A check valve (Fig. 7) just before the injector carrier gas input, preventing sample flashback.
- c) Flow controller in the carrier gas (nitrogen gas) line permitting constant mass flow through column despite pressure changes due to heating and cooling of the column.
- d) Needle valve permitting precise carrier gas flow control.
- e) Three-way switch permitting turn-off of circulating fan when changing column without shutdown of power to the remainder of the instrument.
- f) Automatic injector featuring Teflon and stainless steel parts. Injection volumes variable from 25 μ l to 1.5 ml.
- g) Automatic collection table allowing use of different collection vessels depending on sample volumes, vapour pressure and aerosol formation.
- h) Adjustable recorder signal switch permitting collection of peaks for optimum purity. Collector table actuated only by emergence of each peak, and is, therefore, not affected by minor changes in retention times.
- i) By a simple change, it is possible to convert the instrument to either analytical or preparative operations.

3.7.2.1 Column

The actual separation of sample components is effected in the column where the solid support, type and amount of liquid phase, method of packing, length and temperature are important factors in obtaining the desired resolutions. Analytical columns ordinarily were prepared using 2 to 6 mm i.d. glass tubing or

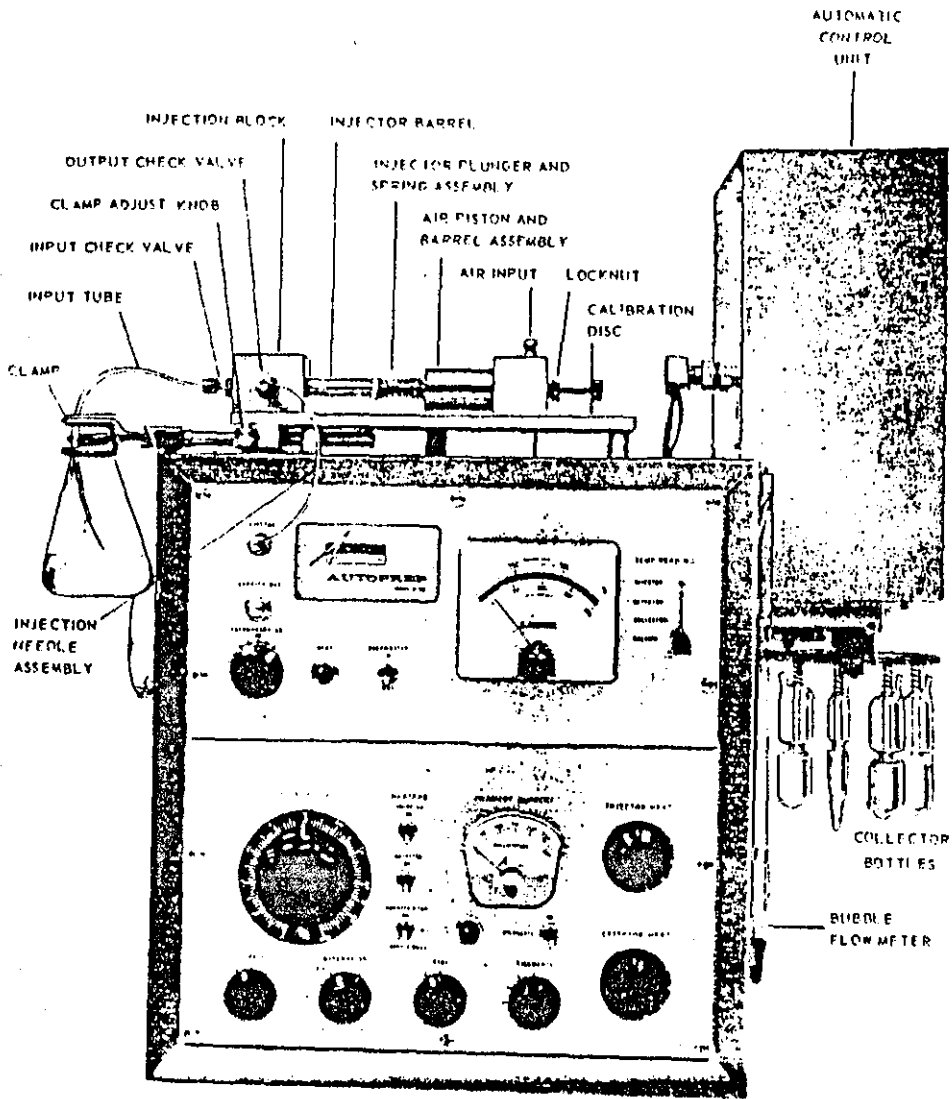

Figure 5 - FRONT VIEW A-700

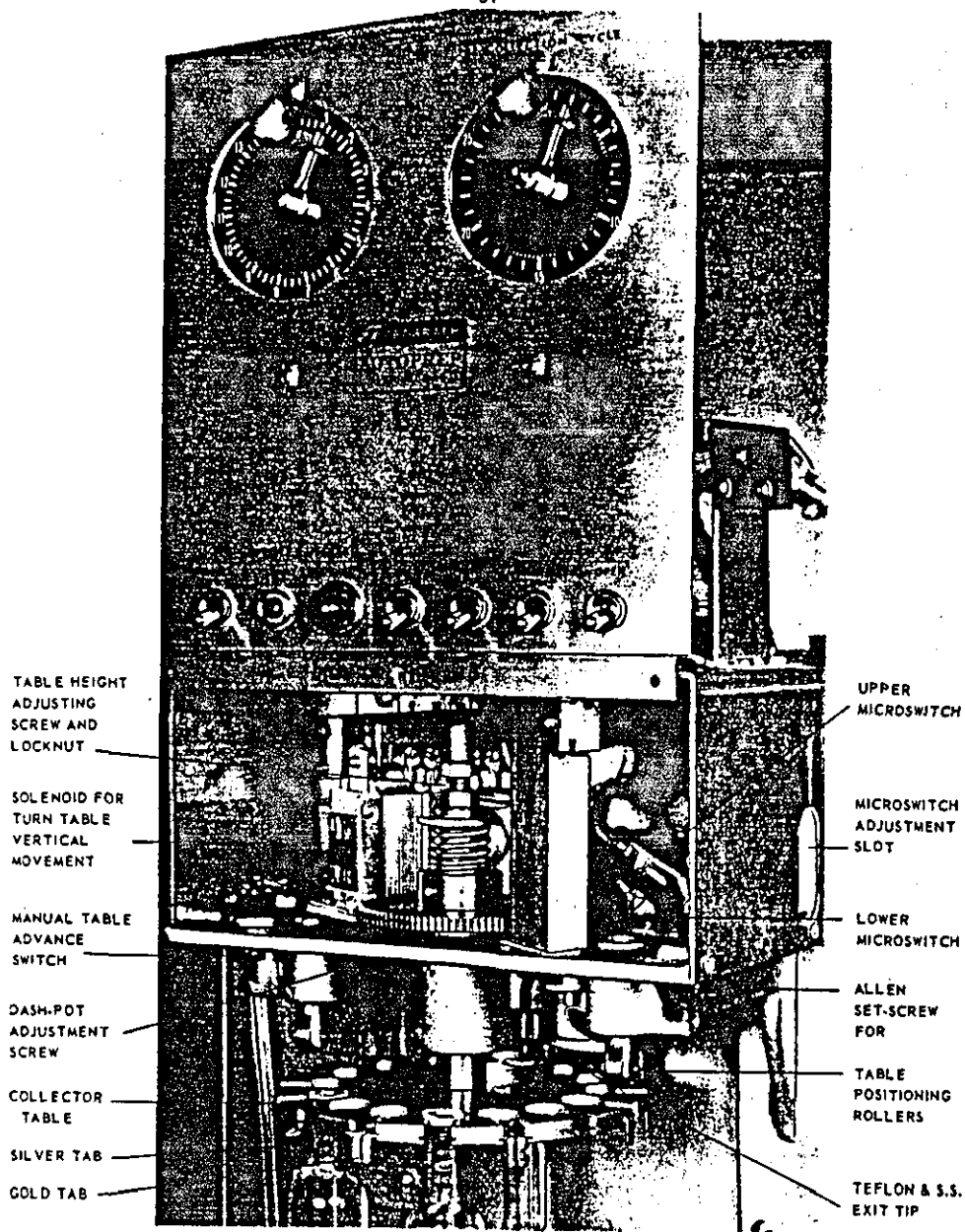

Figure 6 - AUTOMATIC CONTROL UNIT A-700

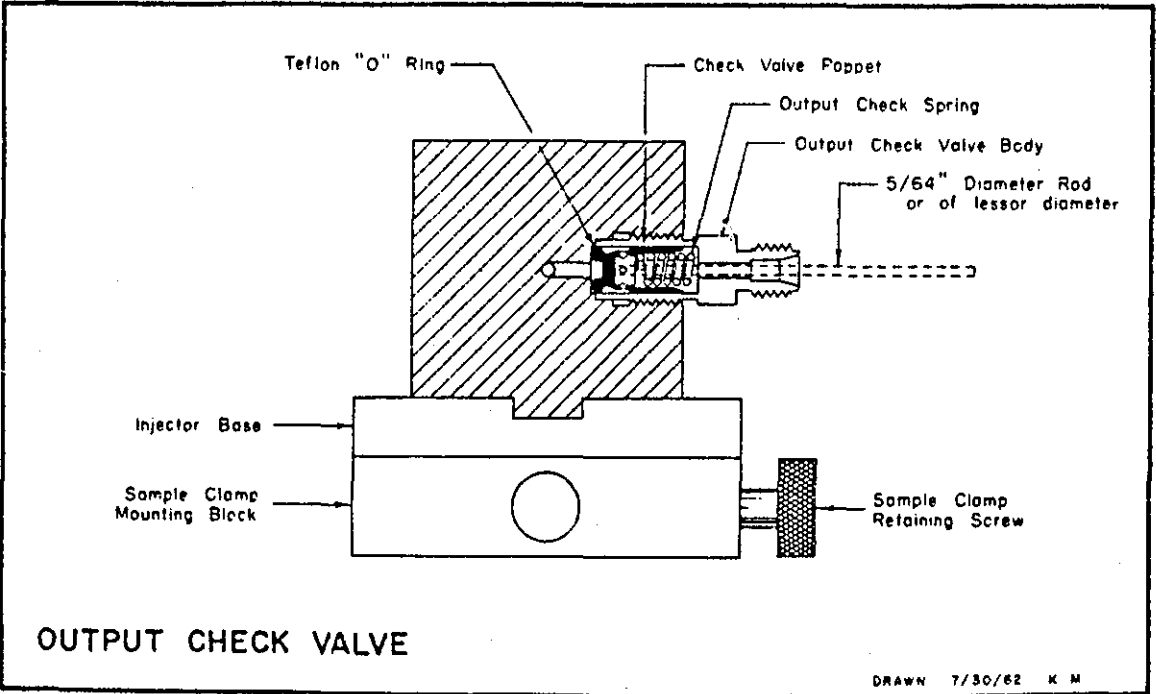
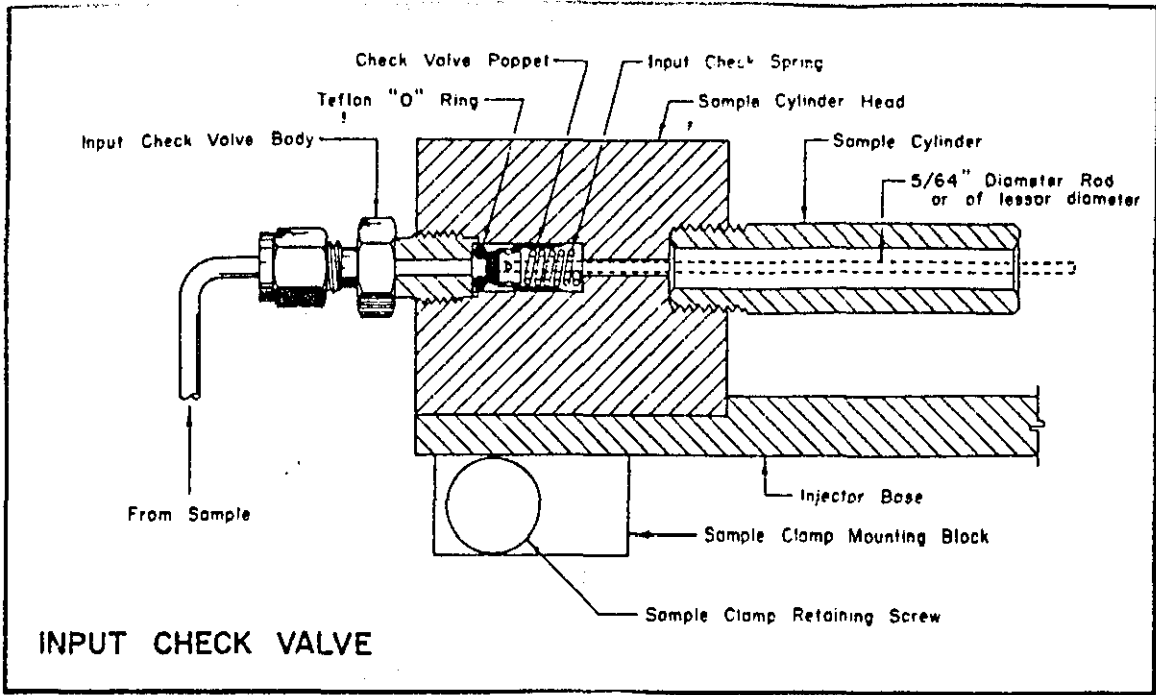

Diagram 7 - CUTAWAY VIEWS OF INJECTOR INPUT & OUTPUT CHECK VALVES A-700

1/8 to 3/8 in. o.d. metal tubing of varying length. The dimensions of the column determine the total of gas and liquid it will contain and therefore the retention time and volume for any solute. Long columns were coiled for compactness after filling and care was taken to avoid crushing the packing in the process.

Three different types of columns were used in this work depending on the chemical and physical properties of the compounds. These columns are:

1. A stainless steel column of 4mm internal diameter with length of 1.5m filled with 10% SE30 on Chromosorb W, 60-80 mesh
2. A glass column of 4m length and 2 mm internal diameter, filled with 15% Carbowax on Chromosorb P.
3. An aluminium column of 20' x 3/8" and 4m in length filled with 5% SE30 on Chromosorb W, 60-80 mesh.

To optimise the conditions required to affect the best resolution of likely products of neutron irradiation of iodotoluene and iodobenzene, the following experiments were performed:

1. The change of peak height with range (sensitivity):
20 μ l of petroleum ether was injected using different ranges and the results are shown below:

Table 3The Effect of Range (Sensitivity) on Peak Height

Range	Ether μ l	Temp. $^{\circ}$ C	N ₂ flowrate ml/min.	Peak Height cm
1				-----
2				-----
3				-----
4				-----
5	20	75 ^o	24	-----
6				-----
7				3.8
8				10.0
9				17.4
10				18.1

2. The efficiency of separation of different compounds that are expected to be produced from the neutron irradiation of o-iodotoluene was investigated at different column temperatures and the results are shown in (Fig. 8 , Fig. 9 , Fig. 10 and the table (4) below.

Table 4

The Effect of Column Temperature on Retention Time

Fraction	Temp. C ^o	Flowrate ml/min.	Retention Time min.
iodomethane			1.3
iodoethane			1.7
iodopropane	50	15	2.4
iodobutane			3.6
iodobenzene			16
iodomethane			3.2
iodoethane			5.0
iodopropane	70	15	9.6
iodobutane			17.8
iodomethane			2.6
iodoethane			3.8
iodopropane	110	15	7.0
iodobutane			12.6

$T = 50^{\circ}\text{C}$
 $R = 7$
 $F.R = 15 \text{ ml/min}$

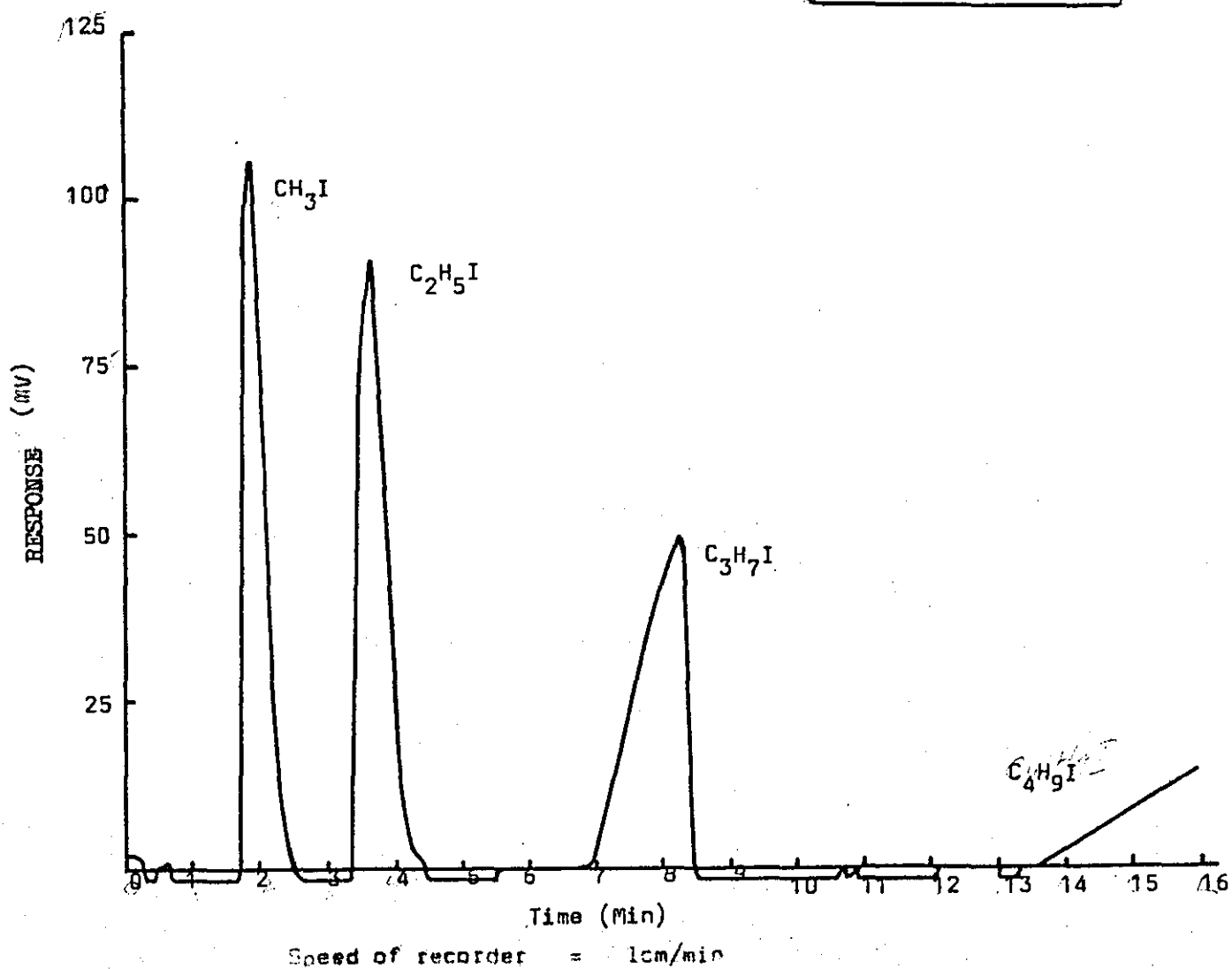

Fig 8 25 μl of a mixture of CH_3I , $\text{C}_2\text{H}_5\text{I}$, $\text{C}_3\text{H}_7\text{I}$
and $\text{C}_4\text{H}_9\text{I}$ in ether.

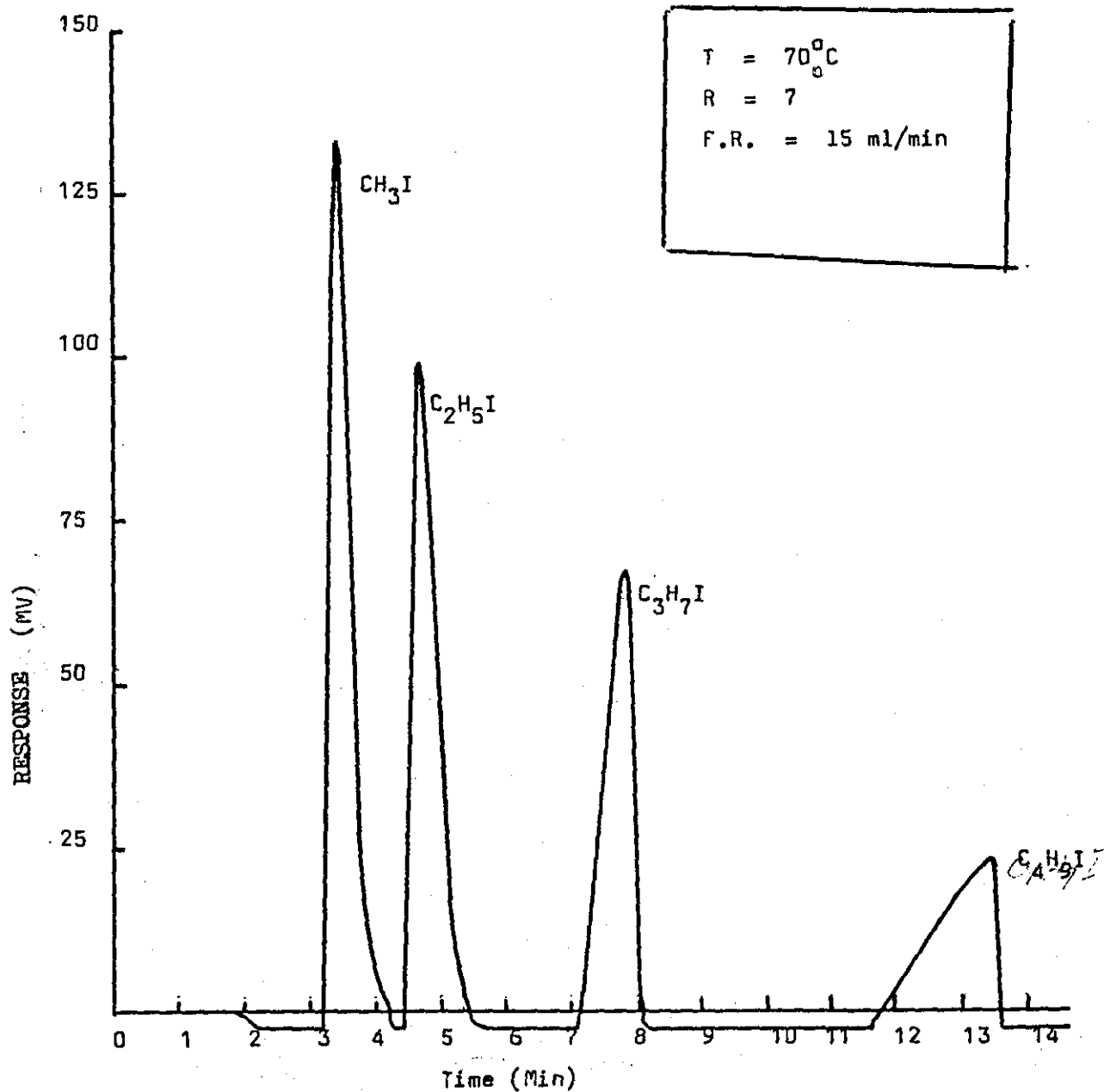

Fig (9) . 25 μ l mixture of CH₃I, C₂H₅I, C₃H₇I, C₄H₉I and ether.

T = 110°C
R = 7
F.R. = 15 ml/min

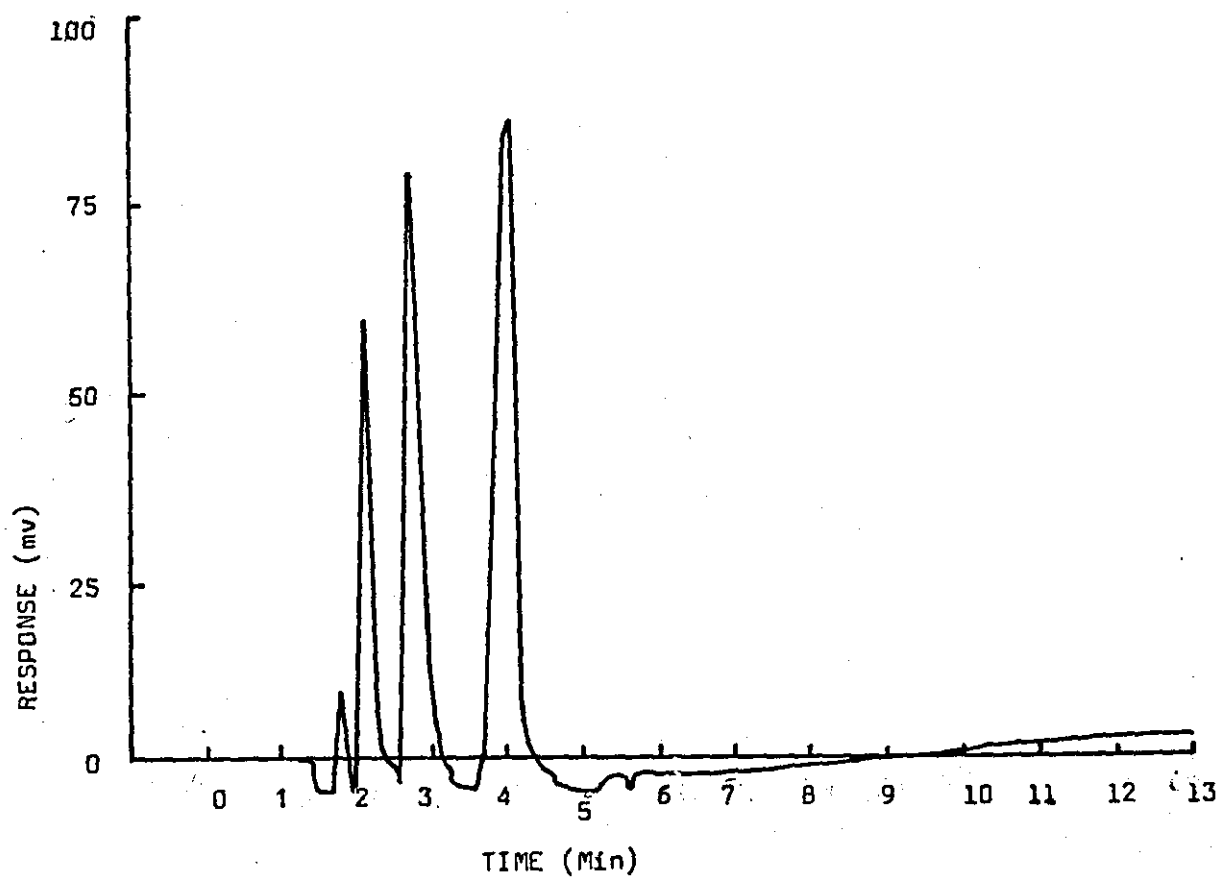

Fig (10) Mix of Ether, CH_3I , $\text{C}_2\text{H}_5\text{I}$, $\text{C}_3\text{H}_7\text{I}$, $\text{C}_4\text{H}_9\text{I}$

3. The efficiency of separation of different injected volumes of a 15% solution of *o*-iodotoluene and iodobenzene in hexane was investigated by injecting 200, 300, 400 and 500 μl of the above solution into the GLC. The results are as shown in Fig. 11, Fig. 12, Fig. 13 and Fig. 14
4. The procedure described in (4) relies on the efficient collection of the compounds eluted from the chromatographic column. To determine the efficiency of collection of such compounds the following procedure was adopted.

Solutions of 1, 2, 3, 4 and 5 μl of iodotoluene in 10 ml of hexane were prepared and the UV absorption spectra recorded on a Cecil 5095 Scanning Spectrophotometer. The solutions were scanned through the wavelength region 200 to 360 nm and hexane was used as the reference. The spectra are shown in Figure 15, and Figure 16 shows a graph of absorbance VS volume of iodotoluene added to each solution. The procedure was repeated with solutions of iodobenzene in hexane and the results are presented in Figures (17, 18).

200 μl of a solution containing 15% of iodotoluene and 15% of iodobenzene in hexane was injected into the GLC and the column effluent was passed through 10 ml of hexane contained in a glass pot. After two minutes collection time, the pot was replaced by another pot containing fresh hexane and the column effluent allowed to pass through the fresh hexane for a further two minutes. The replacement procedure was repeated for fifteen different pots (collection time two minutes each), making a total collection time of thirty minutes. Each portion of hexane was made up to 10 ml with hexane and the UV absorption

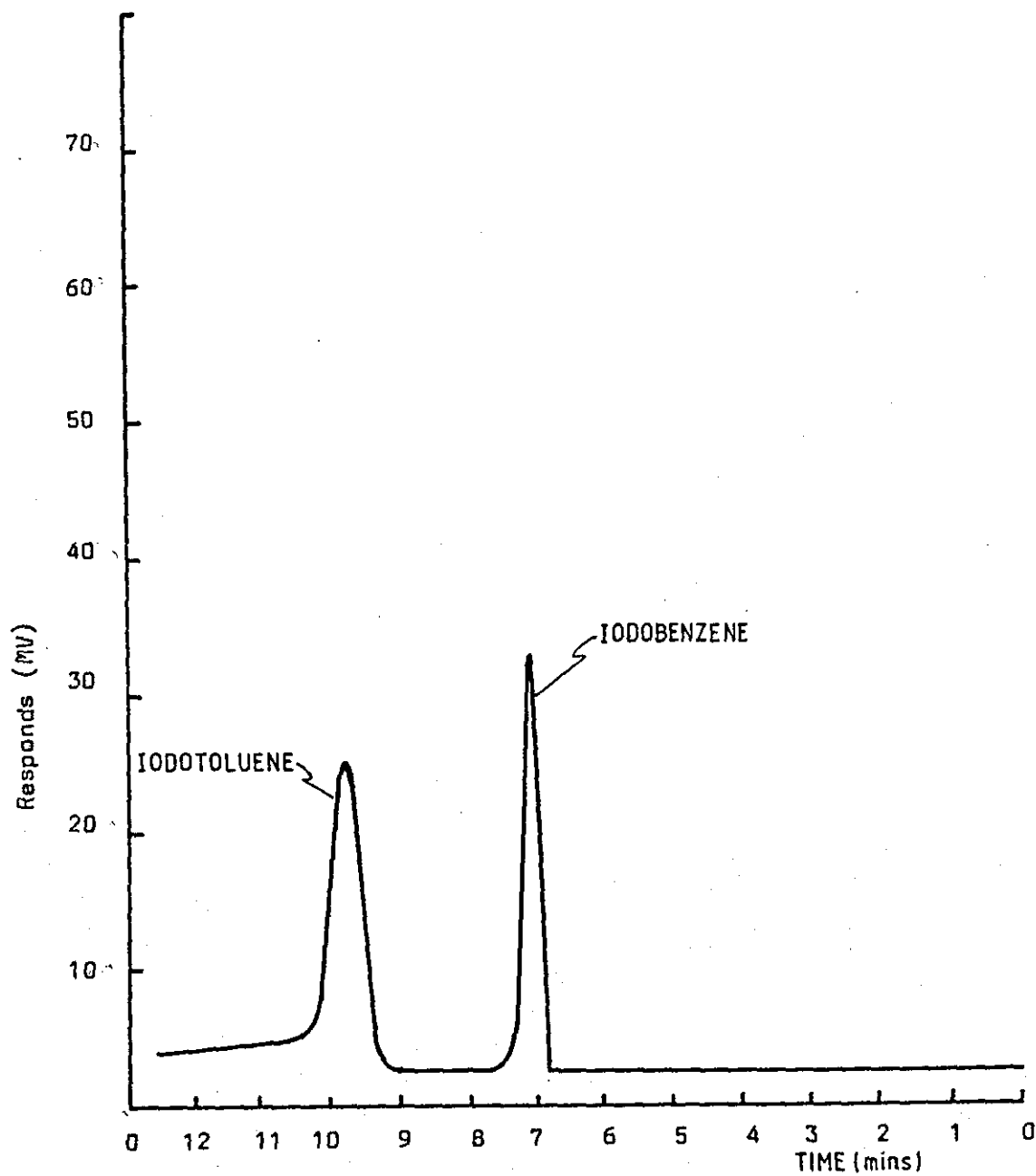

FIG. 11 200 μ l OF 15% SOLUTION OF IODOBENZENE
+ IODOTOLUENE IN HEXANE. SENS = 1.0

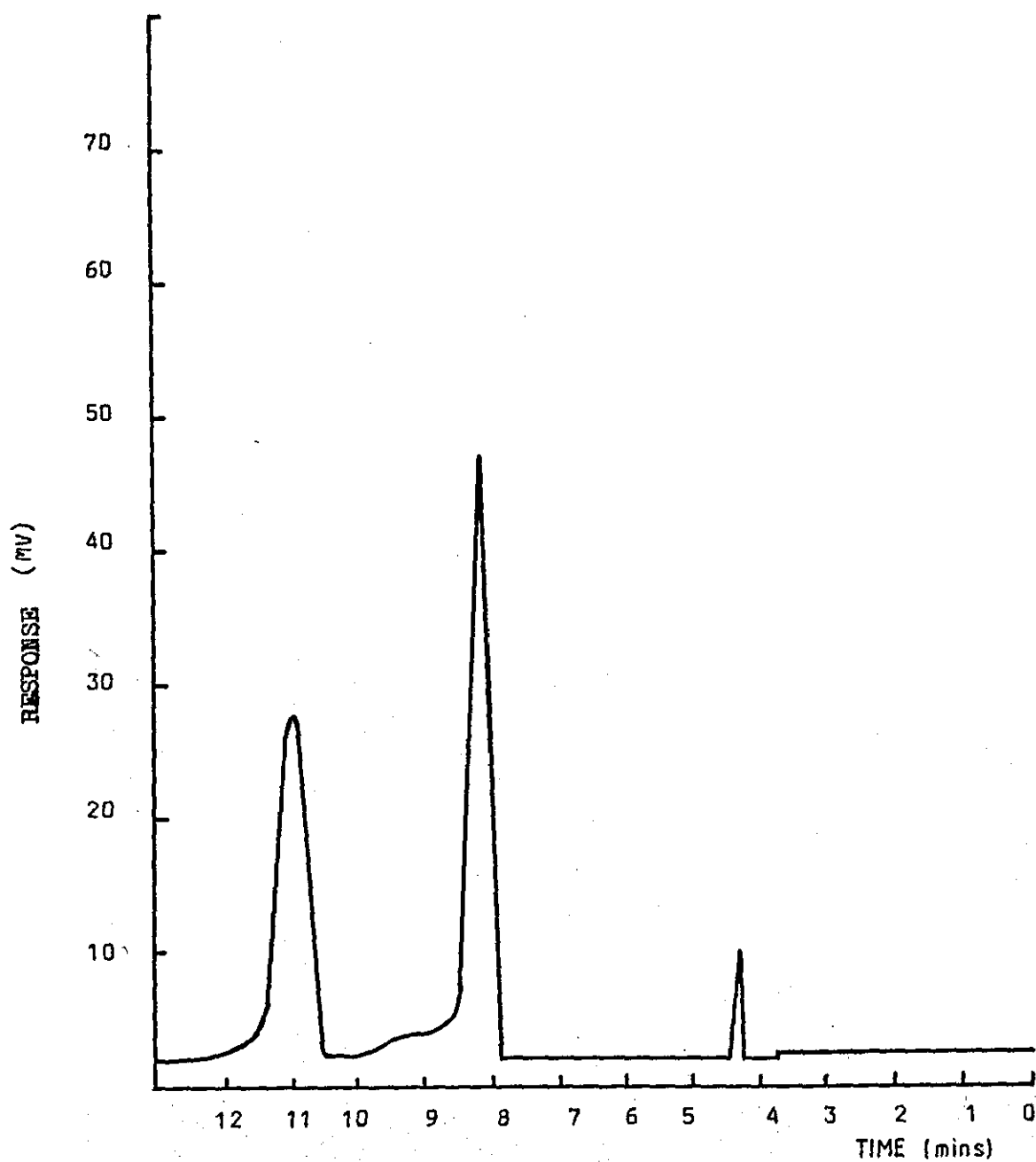

FIG. 12 300 μ l OF 15% SOLUTION OF IODOBENZENE
+ IODOTOLUENE IN HEXANE. SENS = 1.0.

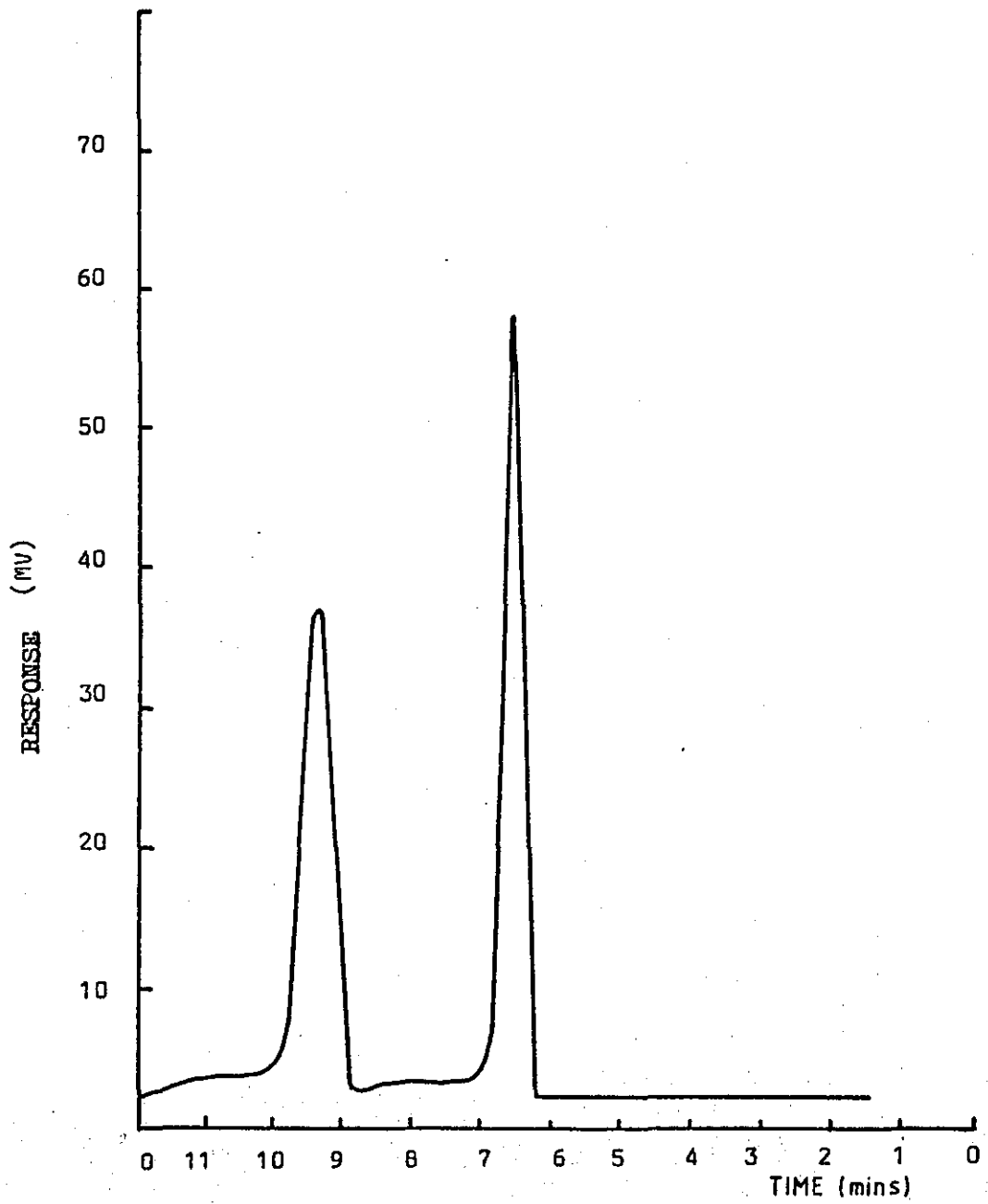

FIG. 13 400 μ l OF 15% SOLUTION OF IODOBENZENE
+ IODOTOLUENE IN HEXANE. SENS = 1.0.

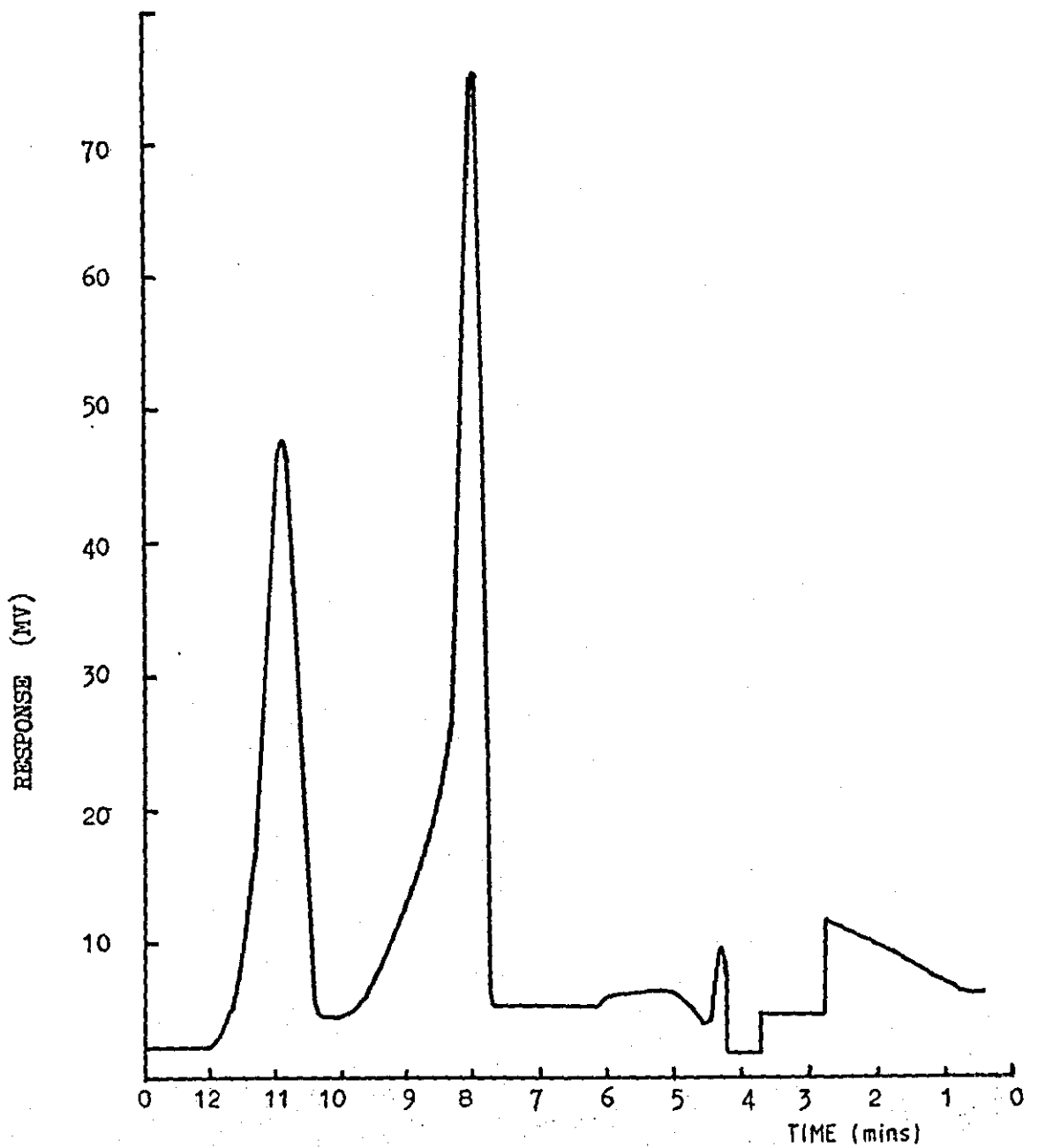

FIG. 14 500 μ l OF 15% SOLUTION OF IODOBENZENE
+ IODOTOLUENE IN HEXANE. SENS = 1.0.

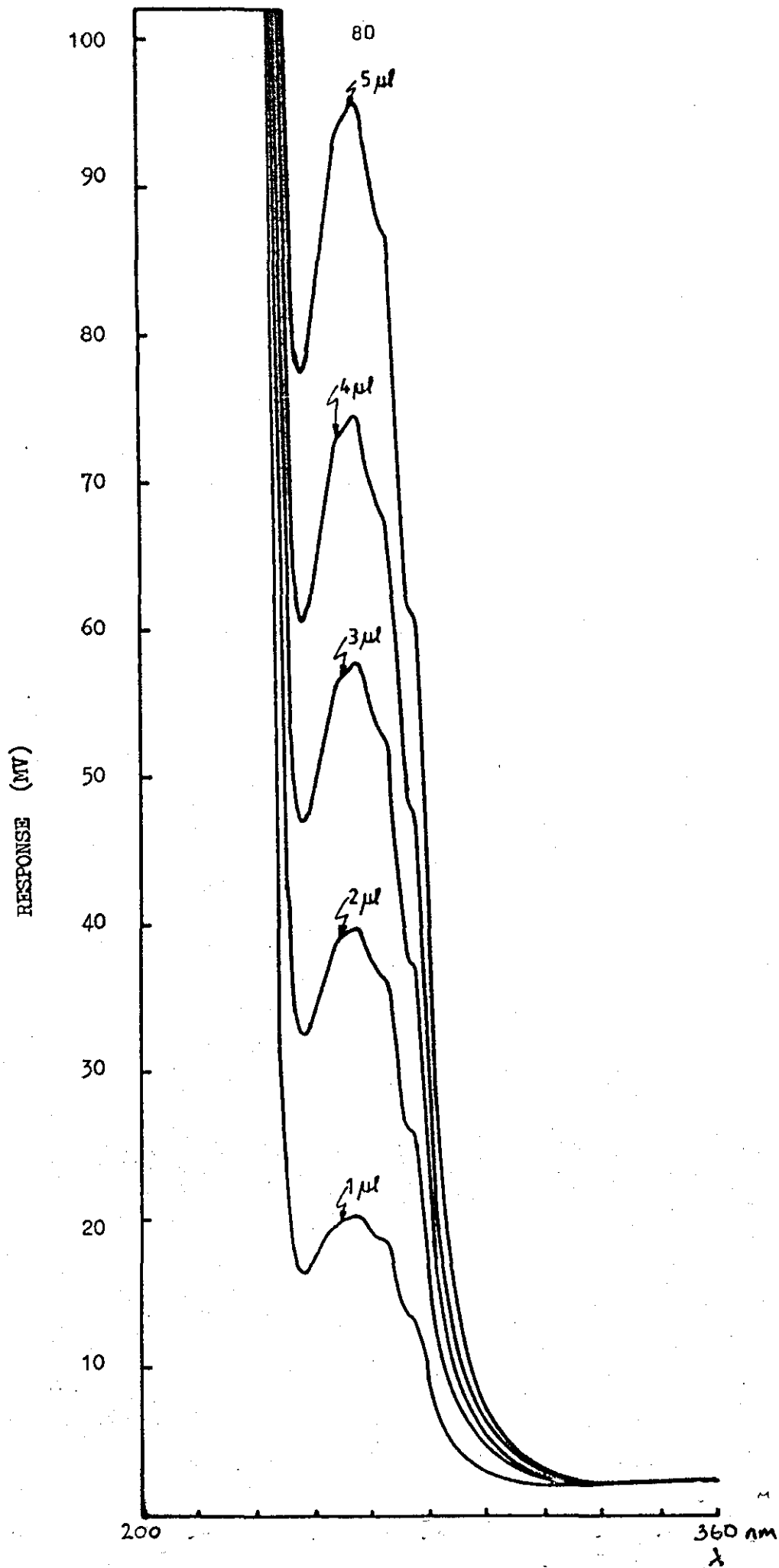

FIG. 15 IODOTOLUENE IN HEXANE 200-360

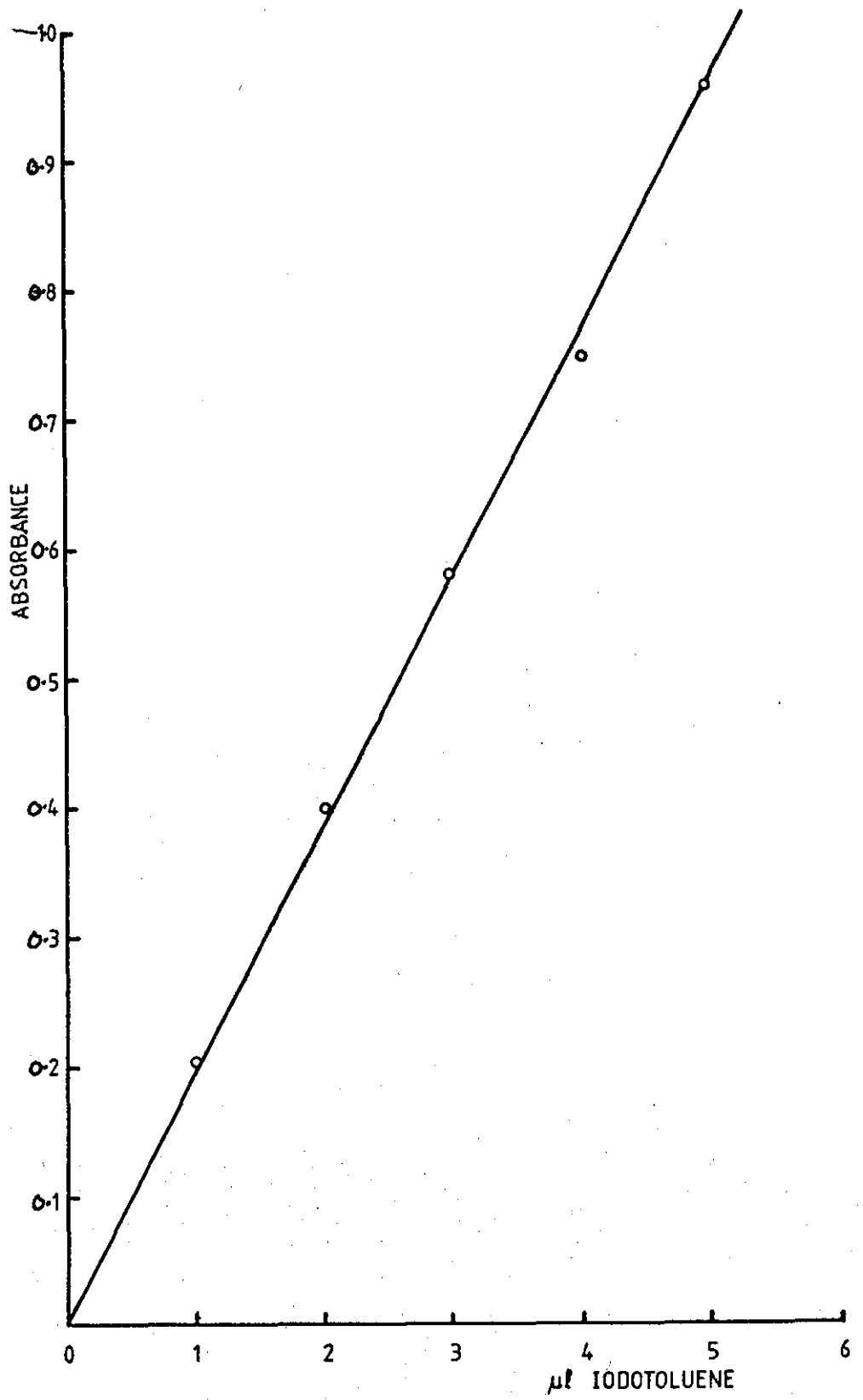

FIG. 16 STANDARD ABSORPTION GRAPH OF
IODOTOLUENE AT 259nm.
RANGE = 0.5

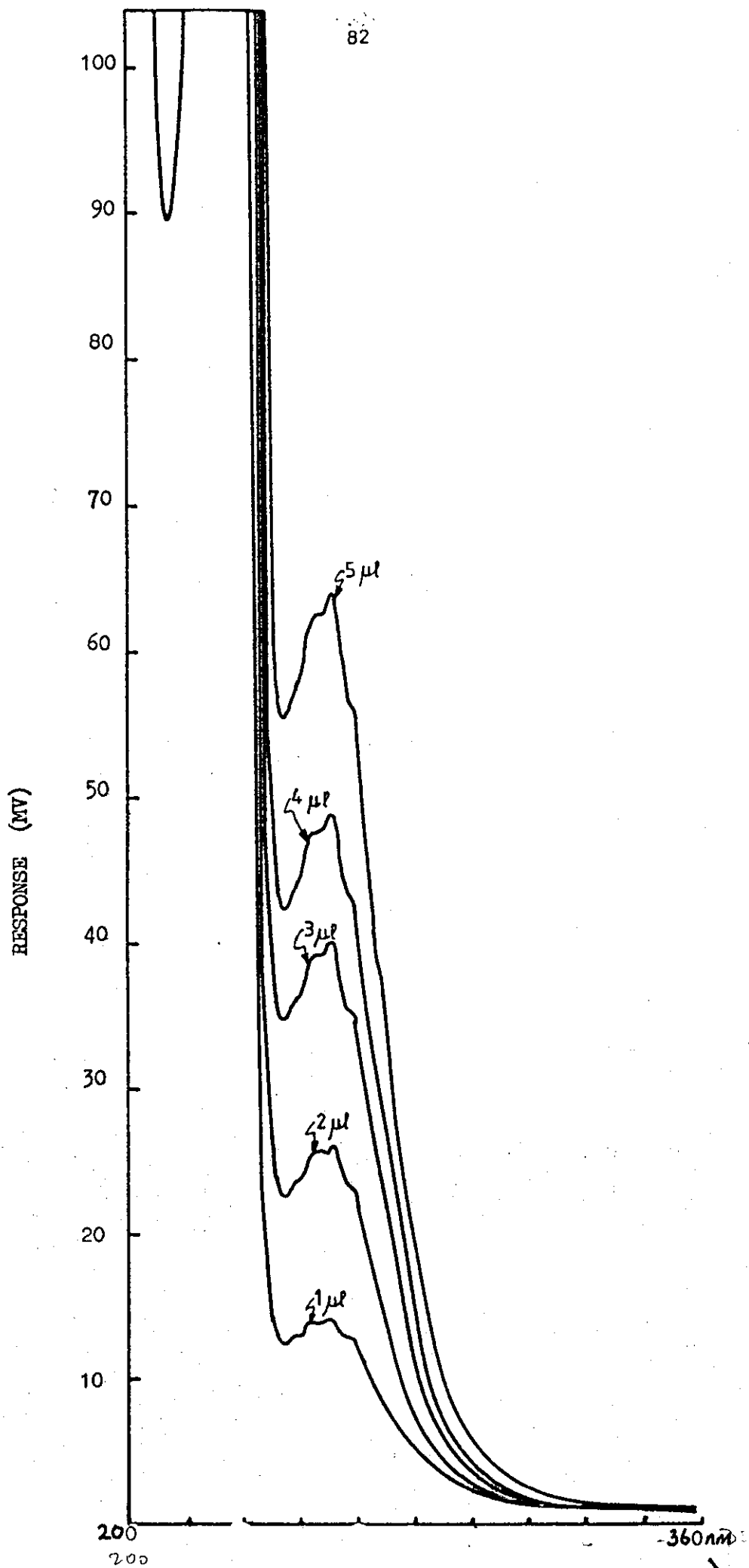

FIG. 17 IODOBENZENE IN HEXANE. 200-400

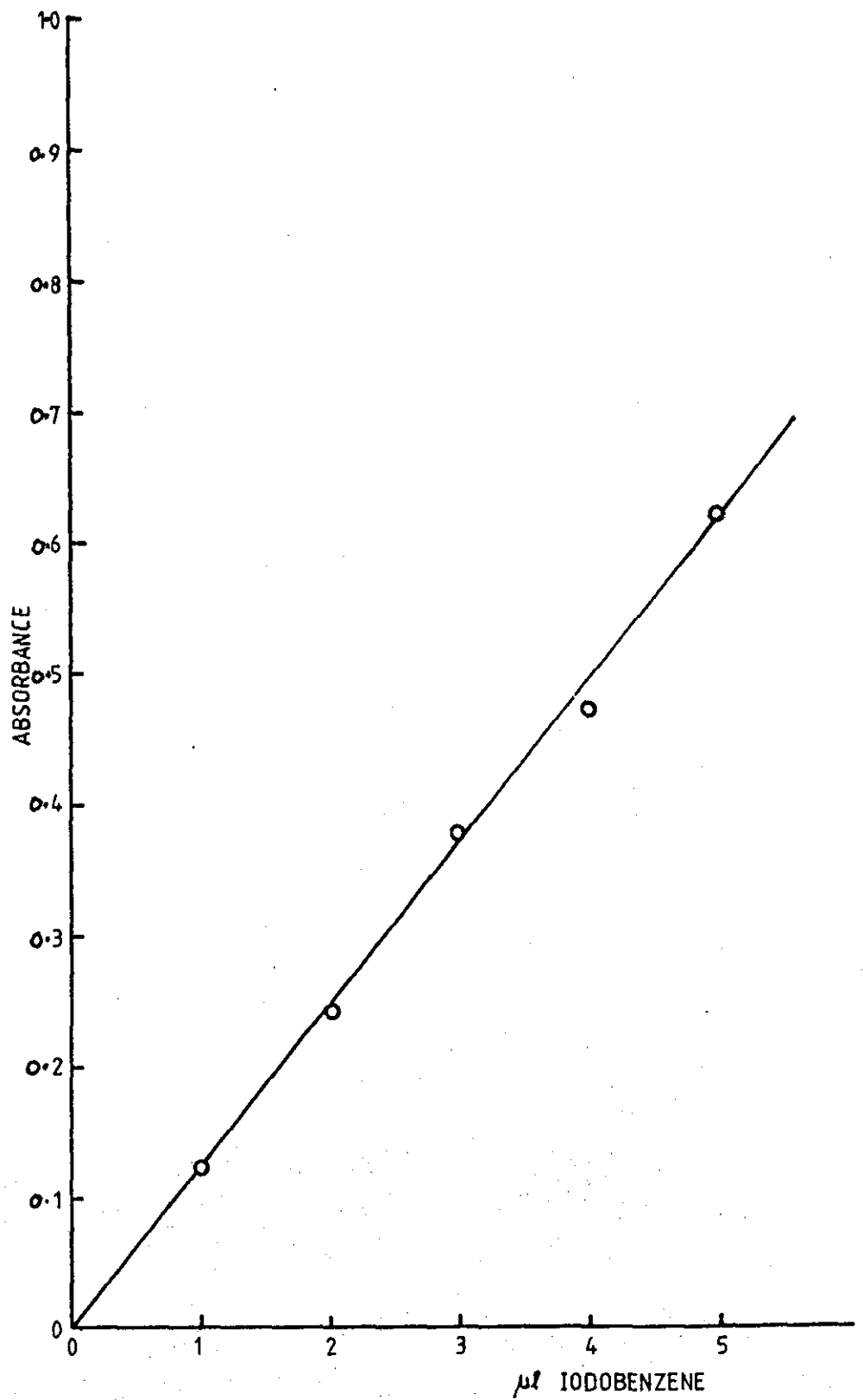

FIG. 18 STANDARD ABSORPTION GRAPH OF
IODOBENZENE IN HEXANE AT 259 nm
RANGE = 1.0

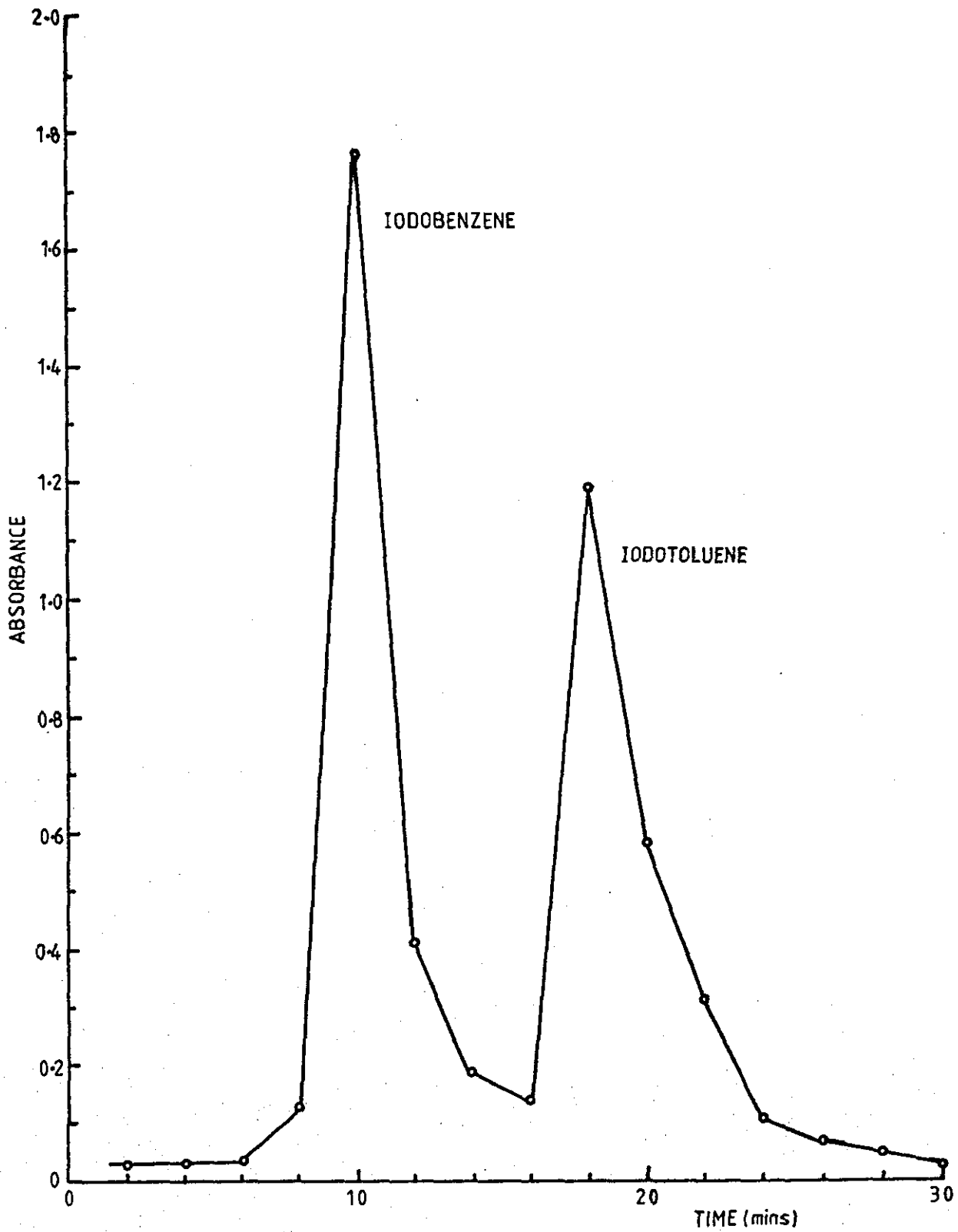

FIG. 19 ABSORPTION GRAPH FROM 2 MIN. G.L.C. SAMPLES. (200 μ l)

spectra determined. Figure 19 shows a graph of absorption against time for the collection of the two peaks.

From the standard graphs (Figures 16 and 17) and Figure 19 it may be calculated that approximately 60% of iodobenzene and 40% of iodotoluene was collected by employing the above procedure.

3.7.2.2. High Pressure Liquid Chromatography

Separation of possible products may also be achieved by H.P.L.C. The system employed during this work consisted of an Altex model 300 high pressure liquid chromatograph (Figure 20 and Figure 21), the main components of which are:

a) Pumping System:

i) Air Supply:

The pump used in this model is a constant pressure pneumatic amplifier which uses nitrogen to drive a large hydraulic piston which, in turn, drives a smaller piston to deliver the mobile phase. The amplification is 23:1, for example, an applied gas pressure of 100 psi would give 2,300 psi of liquid pressure.

ii) Air Drive Section:

The air drive section consists of one or more air driver piston assemblies, a cycling control valve, pilot valves mounted in the upper and lower end caps, a flow tube to direct flow to the top side of the air piston and a pilot tube to connect the upper and lower pilot control valves. The valve operates without springs or detents and is cycled by alternately pressurising and venting an unbalanced pressure operated spool.

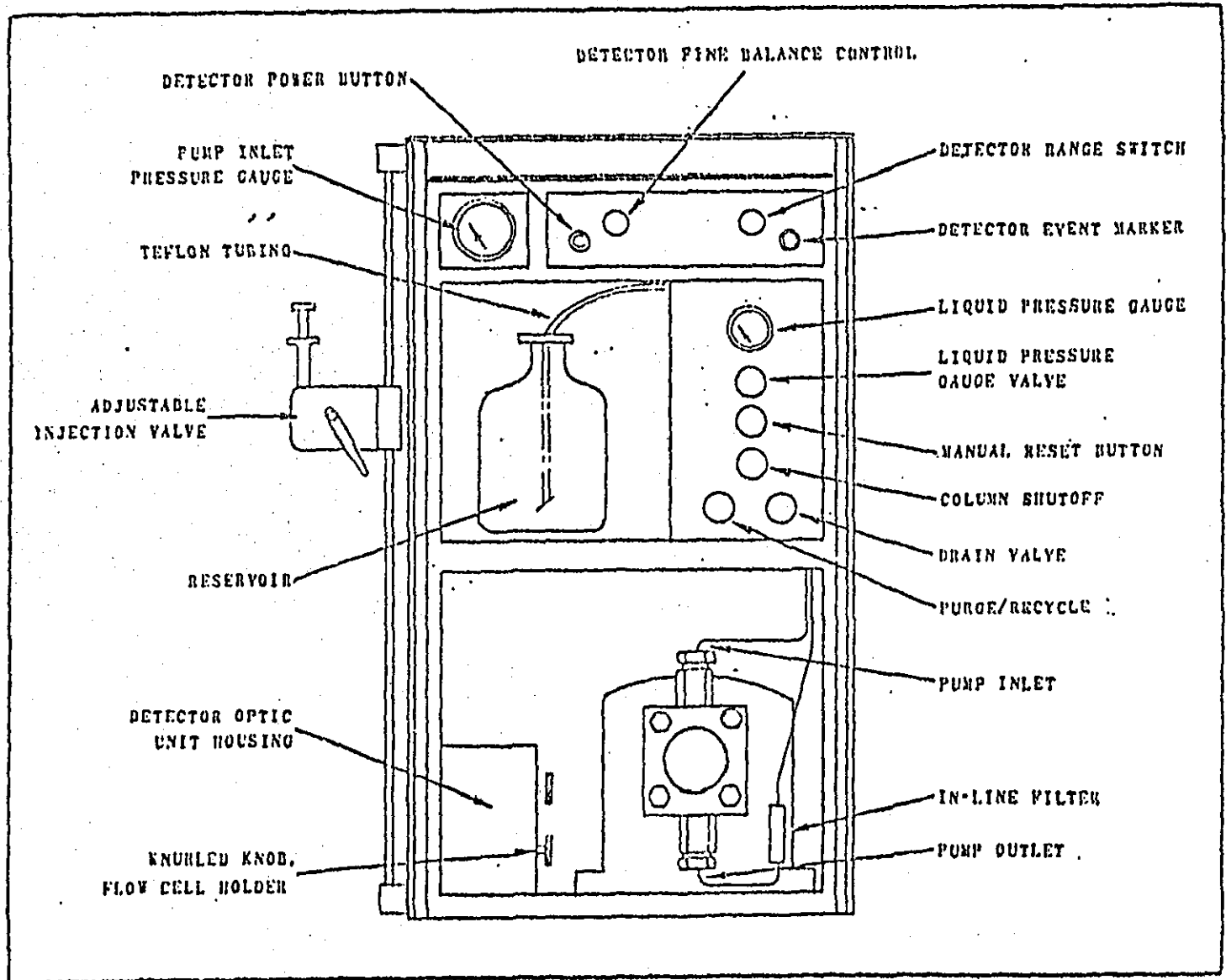
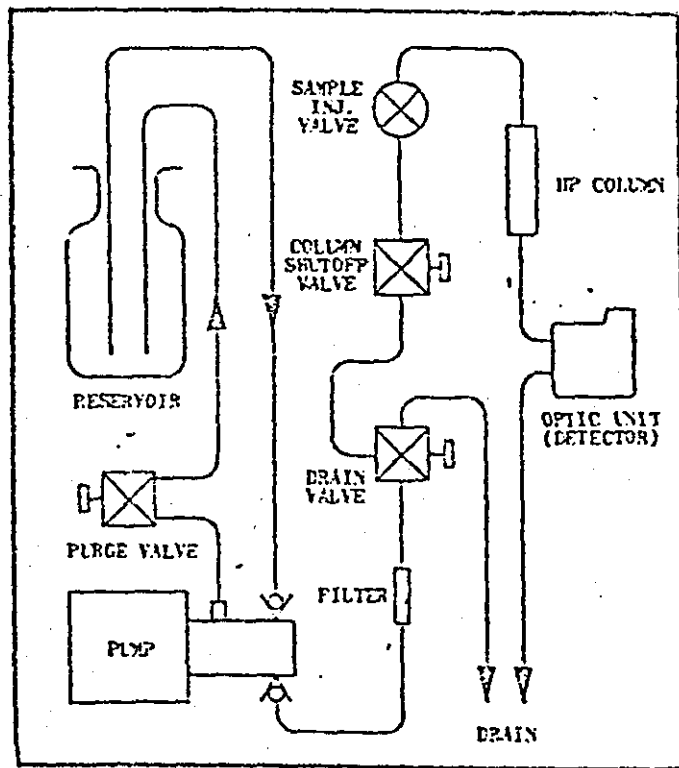

Figure 20. Typical bench placement of the Model 300 and accessories.



Flow Diagram.

FIGURE 21

iii) Hydraulic Liquid Chamber:

The hydraulic liquid chamber is 70 mls and is connected to the reservoir via a check valve. When 70 mls of the liquid has been pumped out, the air pressure is automatically reversed and the pump refills. This refill stroke takes approximately one second. The manual reset button allows the pump to be refilled at any time, e.g. before sample injection. During the refill stroke, a positive liquid flow is maintained by a check valve between the pump and column.

iv) Purge/Recycle Valve:

The three-way recycle valve, or purge valve is located between the pump and reservoir and provides for rapid solvent mixing when a modification of the mobile phase is required. This valve is also used to rid the liquid chamber of air to ensure a full 65 - 70 mls stroke.

b) UV Detector:

The mobile phase eluting from the column was monitored by an Altex Model 150 UV (254 nm) detector employing a 10 mm path length 8 μ l flow cell.

c) High Pressure Sample Injection Valve

The high pressure valve (Altex Model 905) is a rotary switching loop valve with a pressure rating of 3,000 psi, (Fig. 22) shows the flow pattern of the liquid through the valve. This valve has an external removable sample loop with a total injection volume of 500 μ l.

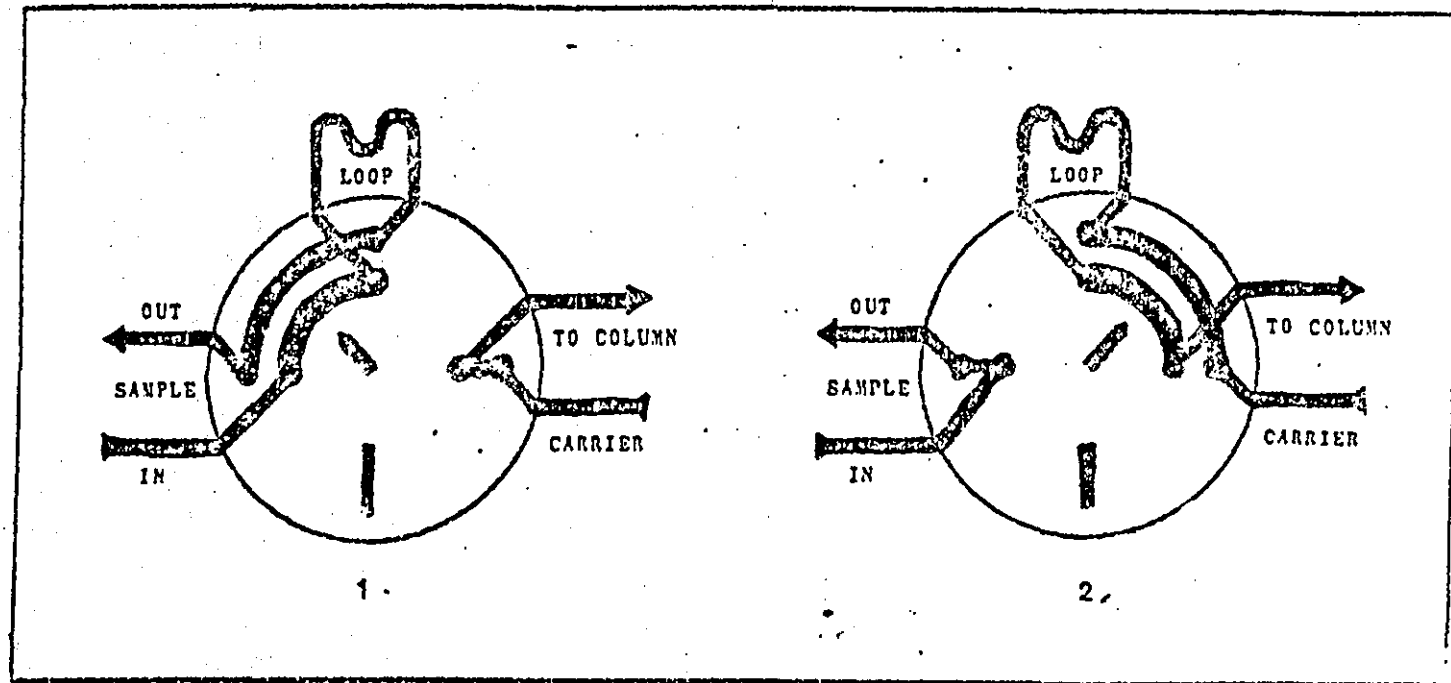

FIGURE 22

High Pressure Sample Injection Valve Flow Pattern.

d) The chromatography column employed throughout this investigation was an RP8, 30 cm x 7 mm (ID) partisil 10 μ m ODS.

K The mobile phase employed to separate iodoethane from iodotoluene was 70% methanol + 30% distilled water.

In order to determine the maximum column loading for the separation of iodotoluene from iodoethane, before the column detector becomes overloaded, the following experiment was performed. K

20 μ l of a mixture containing 5, 10, 15, 20 and 25 per cent of iodotoluene and iodoethane in methanol were injected into the mobile phase and separated in the column.

The results are shown in Figures 23, 24, 25, 26, 27, where it can be seen that column shape and resolution deteriorates at a column loading of 20%.

3.8 Determination of Activity

The amount of radioactivity present in each component after irradiation and extraction is determined by Cerenkov counting in the tritium channel of a liquid scintillation counter.

3.8.1 Liquid Scintillation Counter

A model SL20 liquid scintillation spectrometer was used (Figure 28) because it is mainly designed for counting single or doubly ^{labelled} β -emitting radioactive samples with a good detection efficiency.

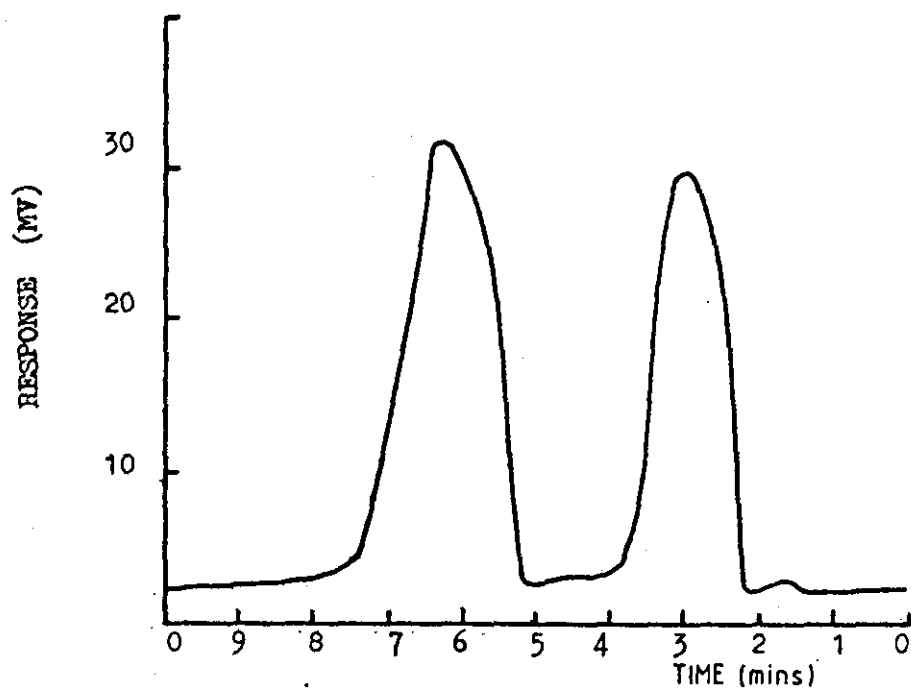

FIG. 23 20 μ l. 5% OF IDOTOLUENE + IDOETHANE
IN METHANOL. R=0.5

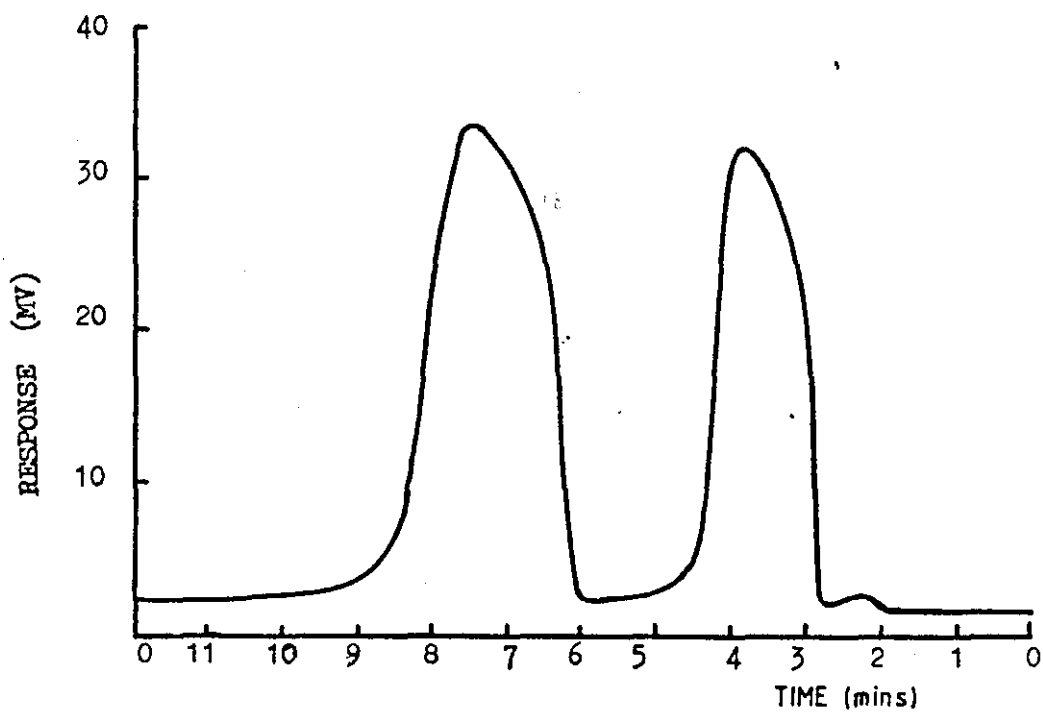

FIG. 24 20 μ l. 10% OF IODOTOLUENE + IODOETHANE IN METANOL. R = 0.5.

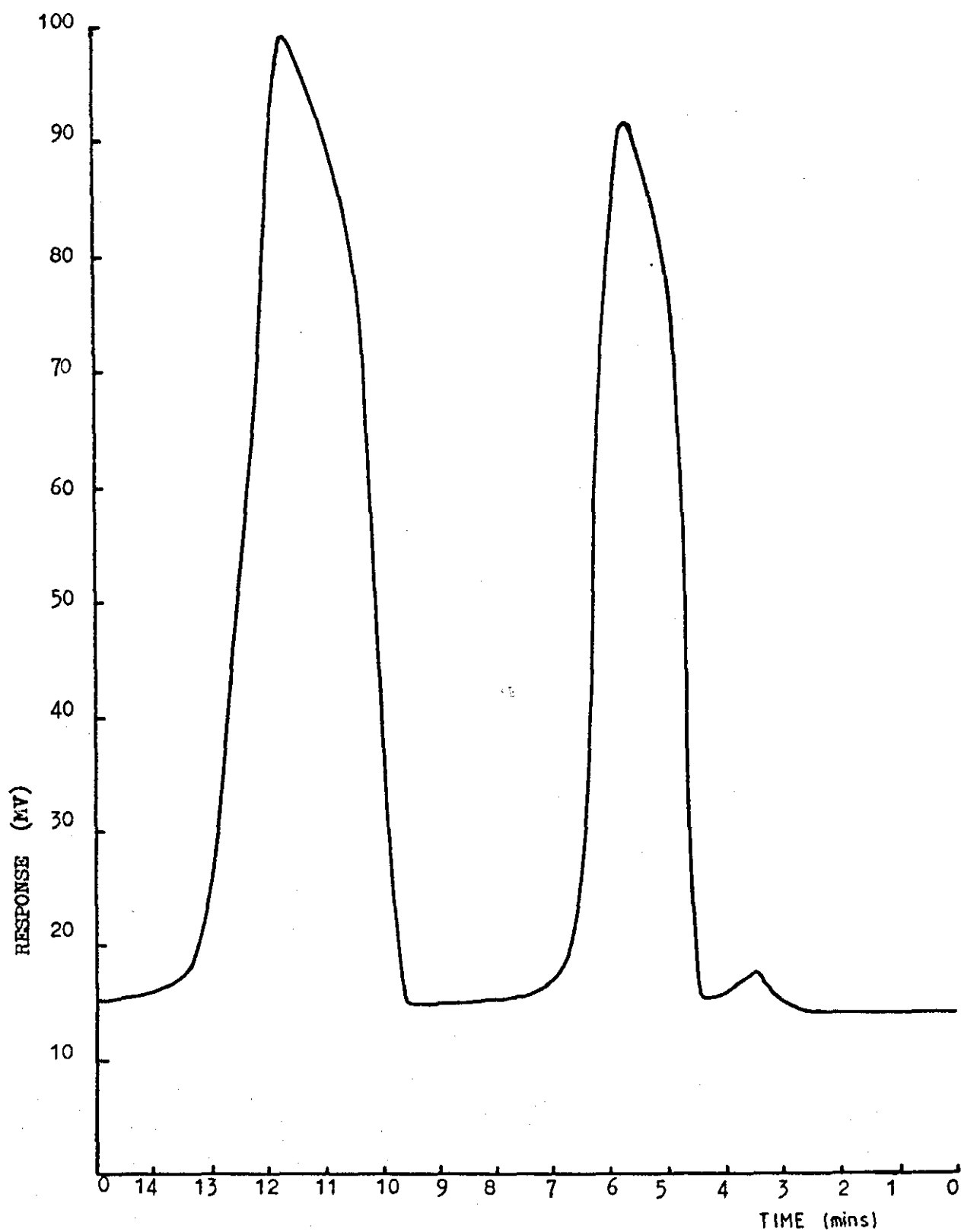

FIG. 25 20 μ l OF 15% IODOTOLUENE + IODOETHANE IN METHANE.
R = 0.2

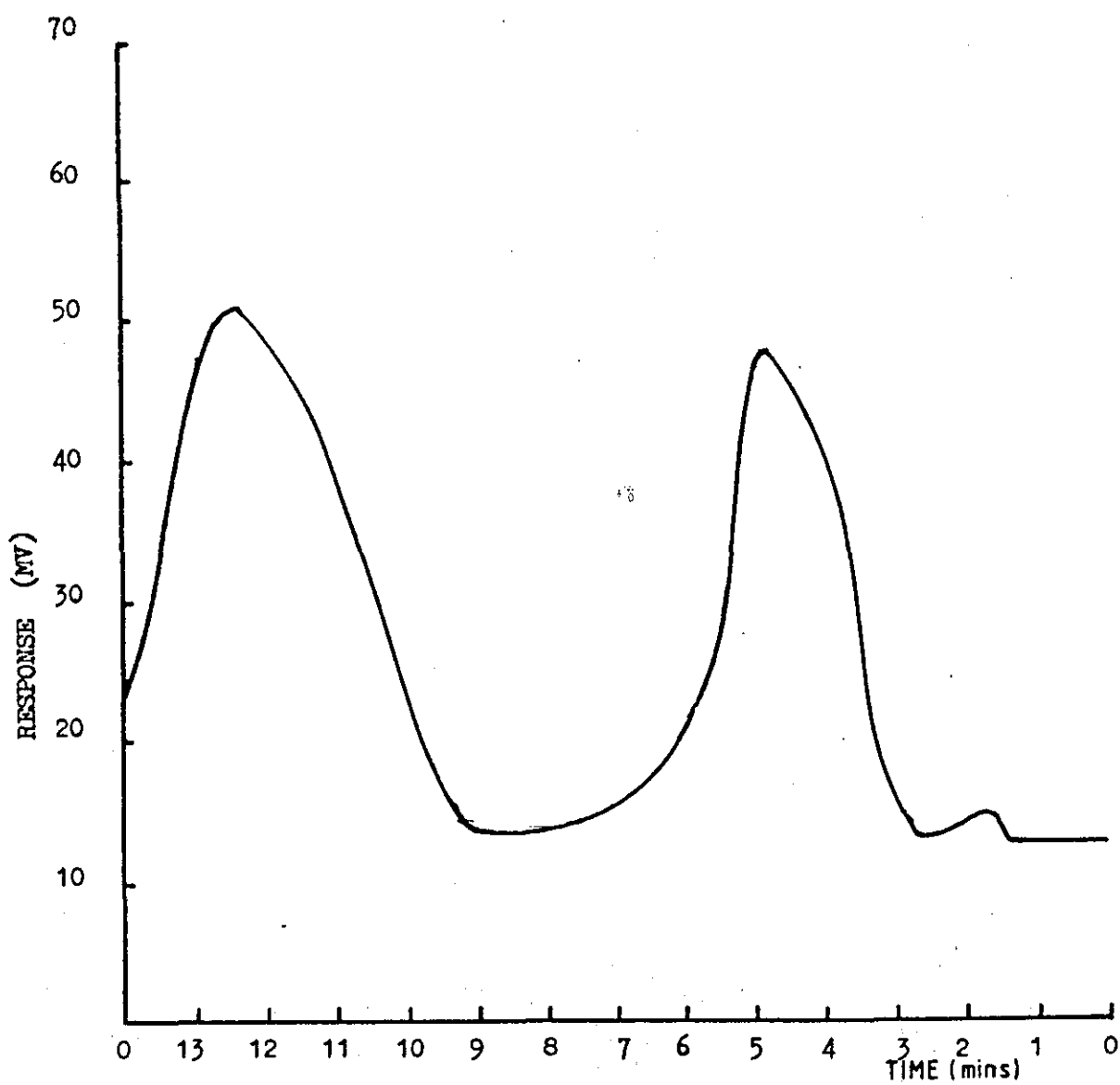

FIG. 26 20 μ l OF 20% IDOTOLUENE + IDOETHANE IN METHANOL. R = 0.5

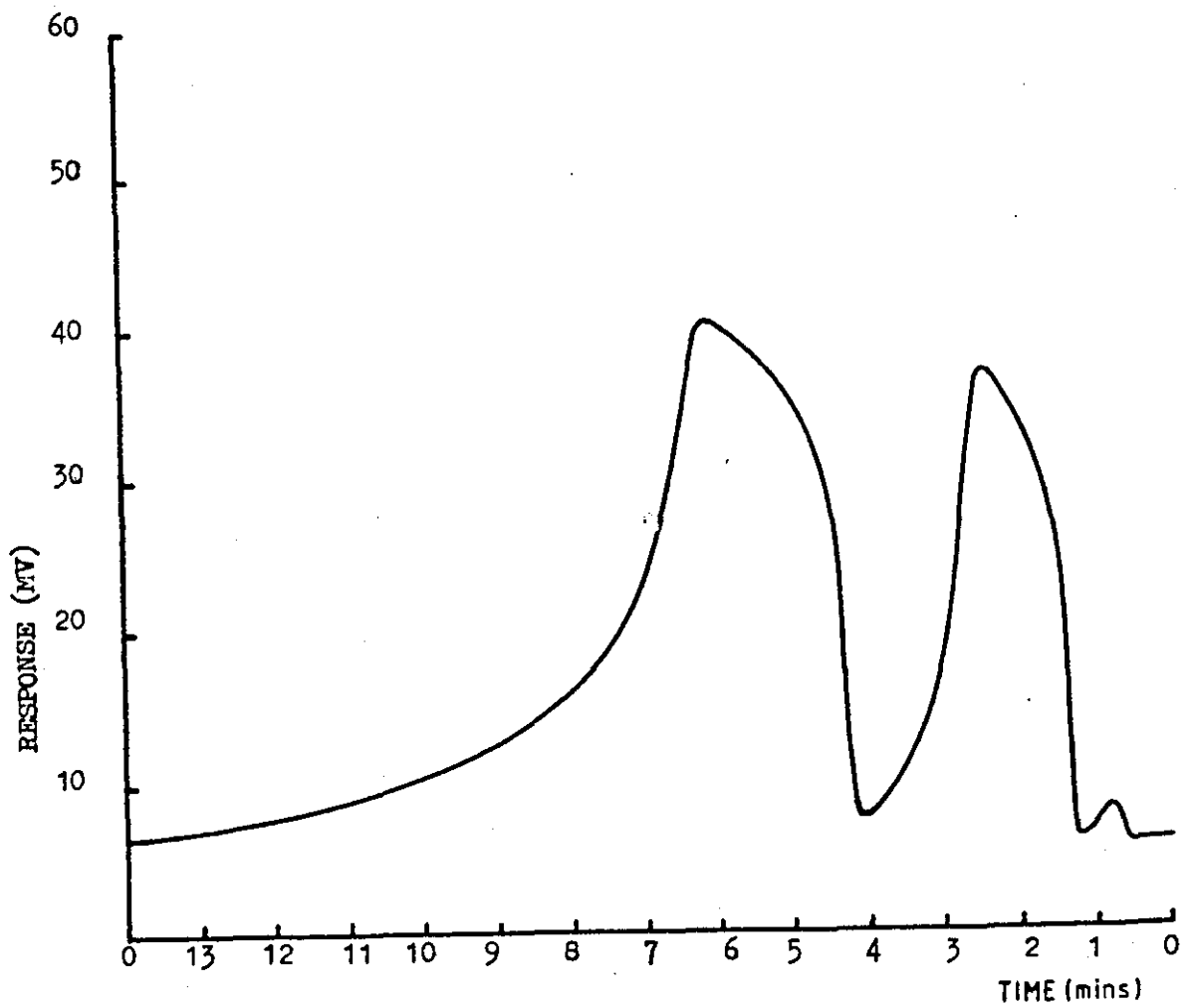

FIG. 27 20 μ l OF 25% IDOTOLUENE + IDOETHANE IN METHANOL.

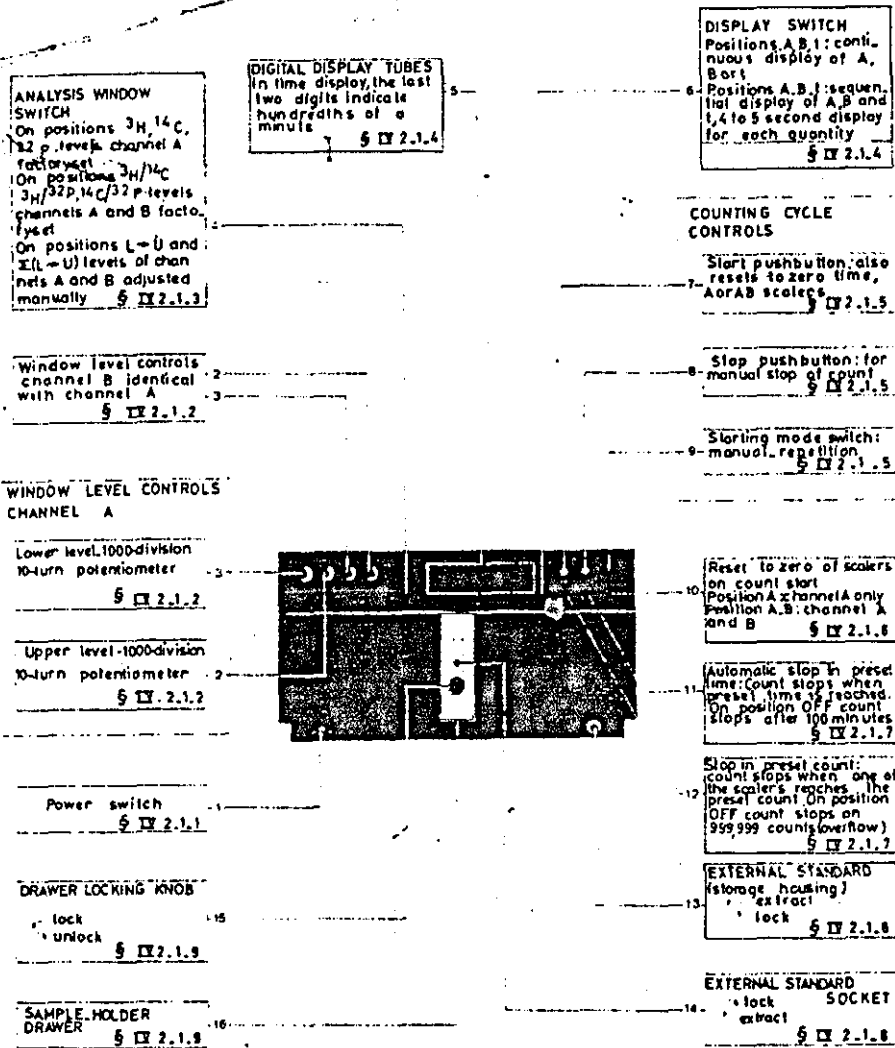

FIG. 28
FRONT PANEL OF SL20 LIQUID SCINTILLATION SPECTROMETER

The specifications of this instrument are:

1. Performances

- a) Sample labelled by a single radioactive isotope, the efficiency for ^3H 50% and the background 25 cpm.
- b) For samples labelled by two radioactive isotopes, the efficiency for ^3H is 45%

2. Detection

- a) Two matched photomultipliers.
- b) Coincidence resolving time: 20 nanoseconds.

3. Amplifier

- a) Logarithmic.
- b) Stability better than 0.02% per $^{\circ}\text{C}$ from 15 to 35 $^{\circ}\text{C}$.

4. Pulse Height Analyzers

- a) Two independent measuring channels.
- b) Counting windows adjustable to 10-turn potentiometer.
- c) Levels preset for measurement of usual isotopes (^3H , ^{14}C , ^{32}P) or for calibration with ^{137}Cs external standard.

5. Preset Count

- a) Common to both channels.
- b) Ten positions:
 $10^3 - 2 \cdot 10^3 - 4 \cdot 10^3 - 10^4 - 2 \cdot 10^4 - 4 \cdot 10^4 -$
 $10^5 - 2 \cdot 10^5 - 4 \cdot 10^5 - 10^6$ counts.

6. Preset Time

- a) Common to both channels

b) Ten positions:

0.1 - 0.2 - 0.4 - 1 - 2 - 4 - 10 -
20 - 40 - 100 minutes.

7. Display

- a) By six decimal display tubes
- b) Provision for continuous display of contents of either channel or count time.
- c) Provision for cyclic display of contents of both channels and of count time, the display time being then of 4 to 5 second for each value

8. Sample Placing

- a) The samples are manually placed into and removed from the counting chamber by operating a drawer on the instrument front panel.
- b) Maximum size of vial is 70 mm high and 20 mm diameter.

9. External Standard

- a) ^{137}Cs .
- b) Placed and removed manually.

10. Outputs Available

- a) Linear gate output pulse for operation with a multi-channel analyzer. Characteristics on 10-Kohn Load:

Polarity	.	positive
Amplitude	.	0.2V to 0.5V
Rise time	.	0.5 μsec

b) Output pulse from each channel

Polarity	.	positive
Amplitude	.	4V \pm 20%
Width	.	0.4 μ sec \pm 20%
Rise time	.	0.2 μ sec
Fall time	.	0.2 μ sec

11. High Voltage Power Supply

- a) Factory-set, from 1500 to 3000 volts.
- b) Stability: in time 0.01% per 24H; in temperature 0.002% per $^{\circ}$ C.

12. Dimensions

- a) 0.67m wide
- b) 0.42m deep
- c) 0.35m high.

3.8.1.1 Sample Container

The container plays an important part in the liquid scintillation system. It should have characteristics such as resistance of attack by solvents and a form which must be convenient etc.

Polyethylene counting vials were used as these had several interesting advantages. They contain no radioactivity and thus significantly reduce background and they are cheaper than glass vials that contain some ^{40}K , an energetic beta-gamma emitter. It has been reported that polyethylene vials also increase counting efficiency. This effect

is quite noticeable with asymmetrical electronic logic counters due to better light dispersion properties of polyethylene relative to glass.

One shortcoming is that polyethylene is attacked by toluene. Toluene has a tendency to distend the vials causing mechanical difficulties with automatic sample changers. Toluene solutions can be counted immediately after preparation and then discarded.

The specifications of the polyethylene vials used are:

1. Features

- a) Low toluene diffusion rate.
- b) Uniform wall thickness.
- c) Dimensionally stable.
- d) Low background.
- e) Self sealing caps.

2. Technical

- a) Background . less than 12 cpm
- b) Wall thickness . $1 \text{ mm} \pm 0.15 \text{ mm}$
- c) Height with cap . $61 \text{ mm} \pm 1 \text{ mm}$
- d) Weight . $5.2\text{g} \pm 5\%$
- e) Material . Linear, high density
high molecular weight,
rigid polyethylene.

3.8.1.2 Cerenkov Radiation

The radioactivity present in each compound after irradiation was measured by Cerenkov counting in the tritium channel of the liquid scintillation counter. This method is used because it does not require the use of scintillators or special solvents and the various emitters may be counted directly in aqueous solutions, suspensions or by other common methods of liquid sample preparation with reasonable efficiencies.

The advantage of this type of counting over normal scintillation counting techniques is that many problems of solubilization are avoided. Moreover it makes possible the counting of samples in strongly acid or alkaline solutions without the necessity for any preparative technique.

CHAPTER 4RESULTS4.1 SCAVENGER STUDY

Scavengers are reactive molecules which are added to systems in which hot-atom reactions are being studied in order to eliminate thermal, radical and ion reactions. Bromine, Iodine, Oxygen and nitric oxide have been widely used. It is always to be hoped that these scavenger molecules will not react to any appreciable extent with the hot species while the latter still retains excess translational energy. It is therefore important to know how much scavenger needs to be added in order that no reactions of thermal atoms shall be observed.

In view of the above findings it was felt necessary to re-investigate some of the scavengers reported in the literature in order to determine the most suitable scavenger for thermal radicals and ion reactions in the light of the scavenger competition effects.

The efficiency of various scavengers (O_2 , Br_2 , I_2 and pyridine) has been investigated for recoil iodine. The purpose of this study was:

- a) To compare our results with those reported in the literature whenever possible and to decide on a scavenger for scavenging thermal radicals and ions.
- b) To determine the optimum amount of the scavenger needed for the study and the degree of scavenger competition (if any) at that concentration and finally

- c) To compare the scavenger curves obtained for *o*-iodotoluene with different scavengers.

Thermal processes generally have very low collision efficiency. On the other hand, hot atom reaction must occur in the few collisions suffered by the hot atom while it is in the appropriate energy region. The addition of small proportion of scavenger, capable of reacting efficiently with the thermalized hot atom, may therefore control thermal reactions which might be mistaken as hot atom processes. The scavenger will not significantly affect hot reactions since a hot atom is unlikely to encounter it during the few collisions of its chemically effective existence. An effective scavenger has a rate constant for reaction with thermalized hot atoms which is sufficiently large that even in small concentrations ^{these reactions} could be investigated.

Iodine, bromine, oxygen and pyridine scavenger curves were obtained for *o*-iodotoluene as shown in Figures 29 - 33, and Tables 5, 6, 7, and 8.

TABLE 5EFFECT OF PYRIDINE AS A SCAVENGER ON O-IODOTOLUENE

Sample No.	pyridine m.f.	Time of Irradiation sec.	BF ₃ Counts	% Organic Yield
1	0.00	60.2	125420	56.26 ± 0.533
2	0.001	60.1	125113	53.53 ± 0.546
3	0.010	60.2	126557	52.61 ± 0.543
4	0.100	60.4	124046	50.72 ± 0.531
5	0.200	61.0	125003	50.91 ± 0.532
6	0.300	60.3	124194	51.08 ± 0.593
7	0.400	60.6	124229	50.59 ± 0.578

TABLE 6EFFECT OF OXYGEN AS A SCAVENGER ON O-IODOTOLUENE

Sample No.	O ₂ Mole%	Time of Irradiation sec.	BF ₃ Counts	%Organic Yield
1	0.00	60.4	127638	56.26 ± 0.423
2	0.05	61.2	128615	54.81 ± 0.505
3	0.10	60.0	125979	50.98 ± 0.442
4	0.15	59.9	126110	52.37 ± 0.529
5	0.20	60.3	132331	52.20 ± 0.511
6	0.25	61.0	133024	51.88 ± 0.498
7	0.30	59.7	127284	51.89 ± 0.465
8	0.35	60.6	127099	52.11 ± 0.487

TABLE 7EFFECT OF BROMINE AS A SCAVENGER ON O-IODOTOLUENE

Sample	Br ₂ Mole%	Time of Irradiation sec	BF ₃ Counts	% Organic Yield
1	0.0	60.1	71000	56.26 ± 0.572
2	0.5	60.3	711540	51.37 ± 0.566
3	1.0	60.3	68410	53.92 ± 0.541
4	1.5	60.8	65114	52.18 ± 0.553
5	2.0	60.4	64222	50.48 ± 0.545
6	2.5	59.8	66015	49.06 ± 0.545
7	3.0	61.1	69482	48.98 ± 0.540
8	3.5	60.0	68825	49.00 ± 0.544

TABLE 8

EFFECT OF IODINE AS A SCAVENGER ON O-IODOTOLUENE

Sample No.	I ₂ Mole%	Time of Irradiation sec.	BF ₃ Counts	% Organic Yield
1	0.00	65.6	381419	56.26 ± 0.528
2	0.001	64.1	179975	50.64 ± 0.524
3	0.010	68.3	192624	38.18 ± 0.500
4	0.100	63.0	198637	27.31 ± 0.517
5	0.200	66.0	203052	25.93 ± 0.512
6	0.300	65.3	260112	25.38 ± 0.387
7	0.400	65.9	220342	26.30 ± 0.383
8	0.500	65.4	236240	24.98 ± 0.382

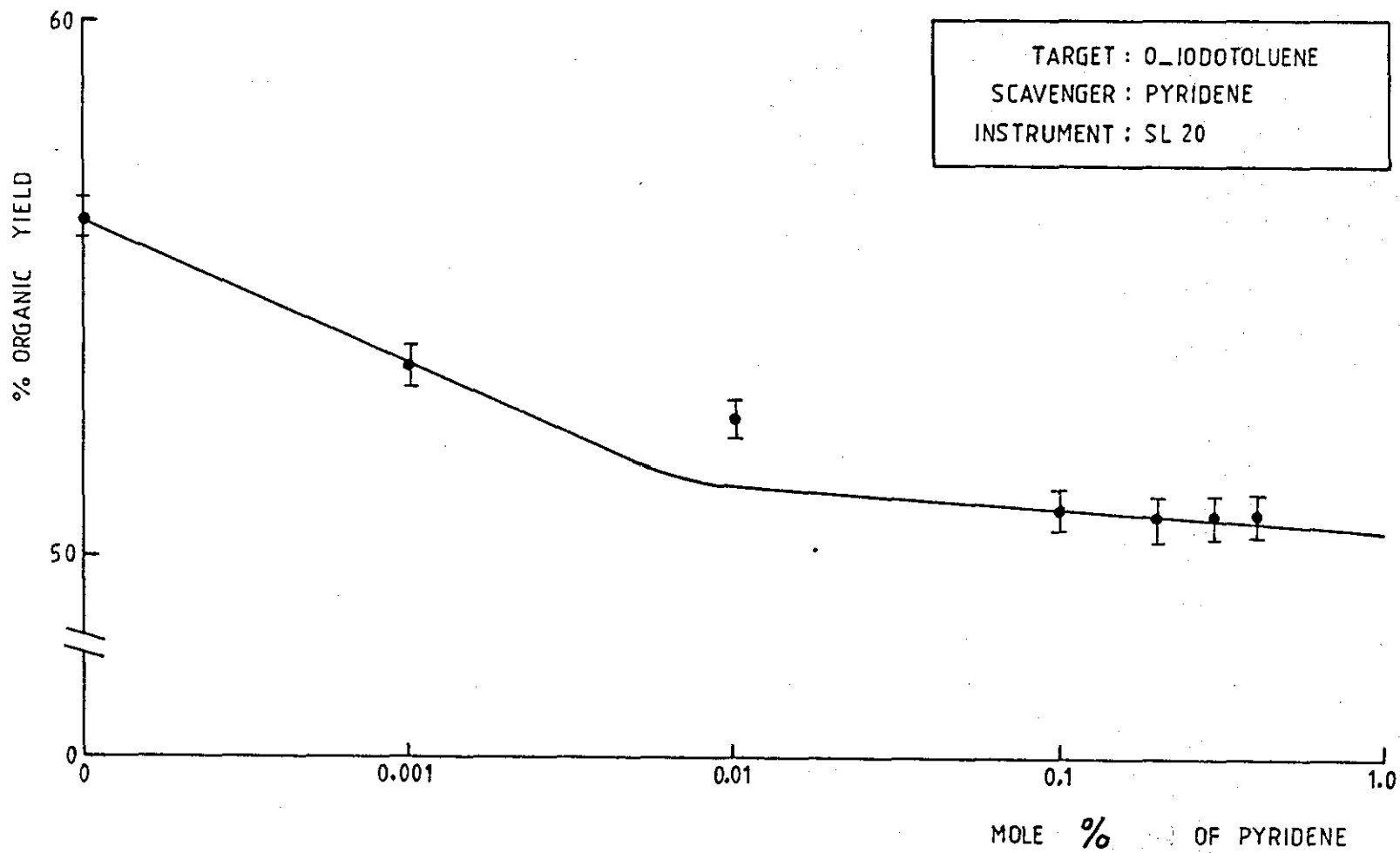

FIG. 29. EFFECT OF PYRIDENE ON THE ORGANIC YIELD.

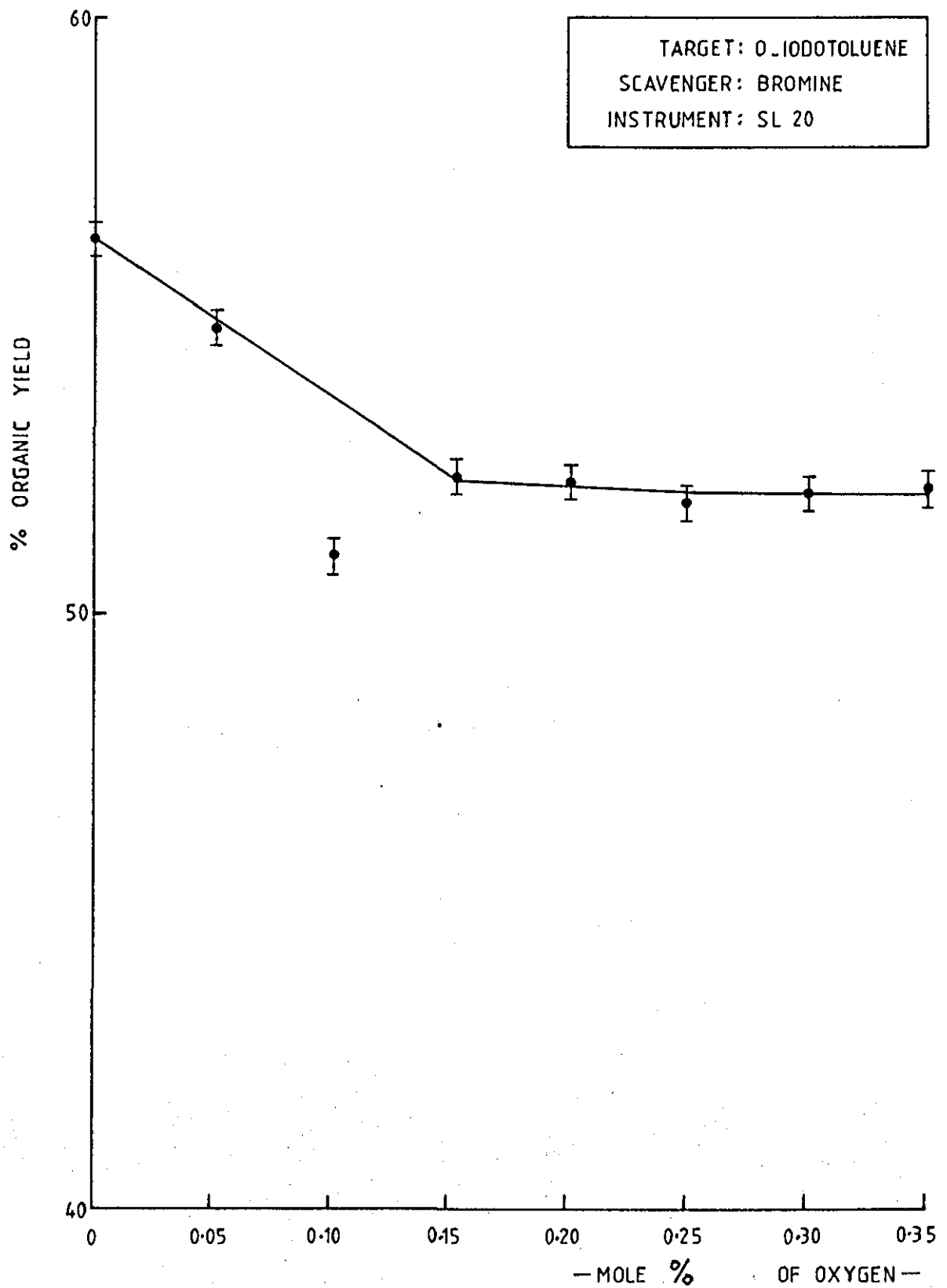

FIG. 30. EFFECT OF OXYGEN ON THE ORGANIC YIELD.

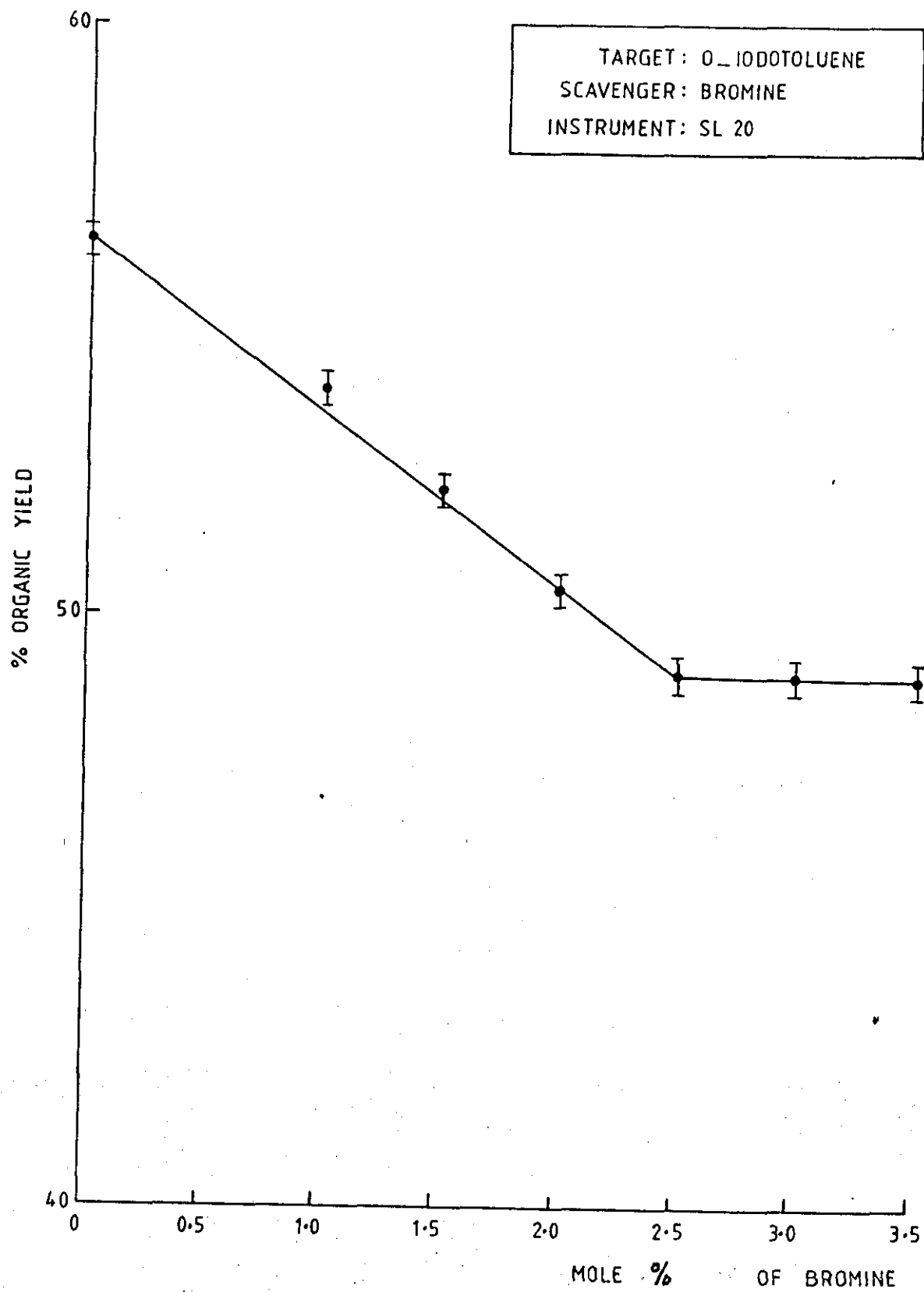

FIG. 31. EFFECT OF BROMINE ON THE ORGANIC YIELD.

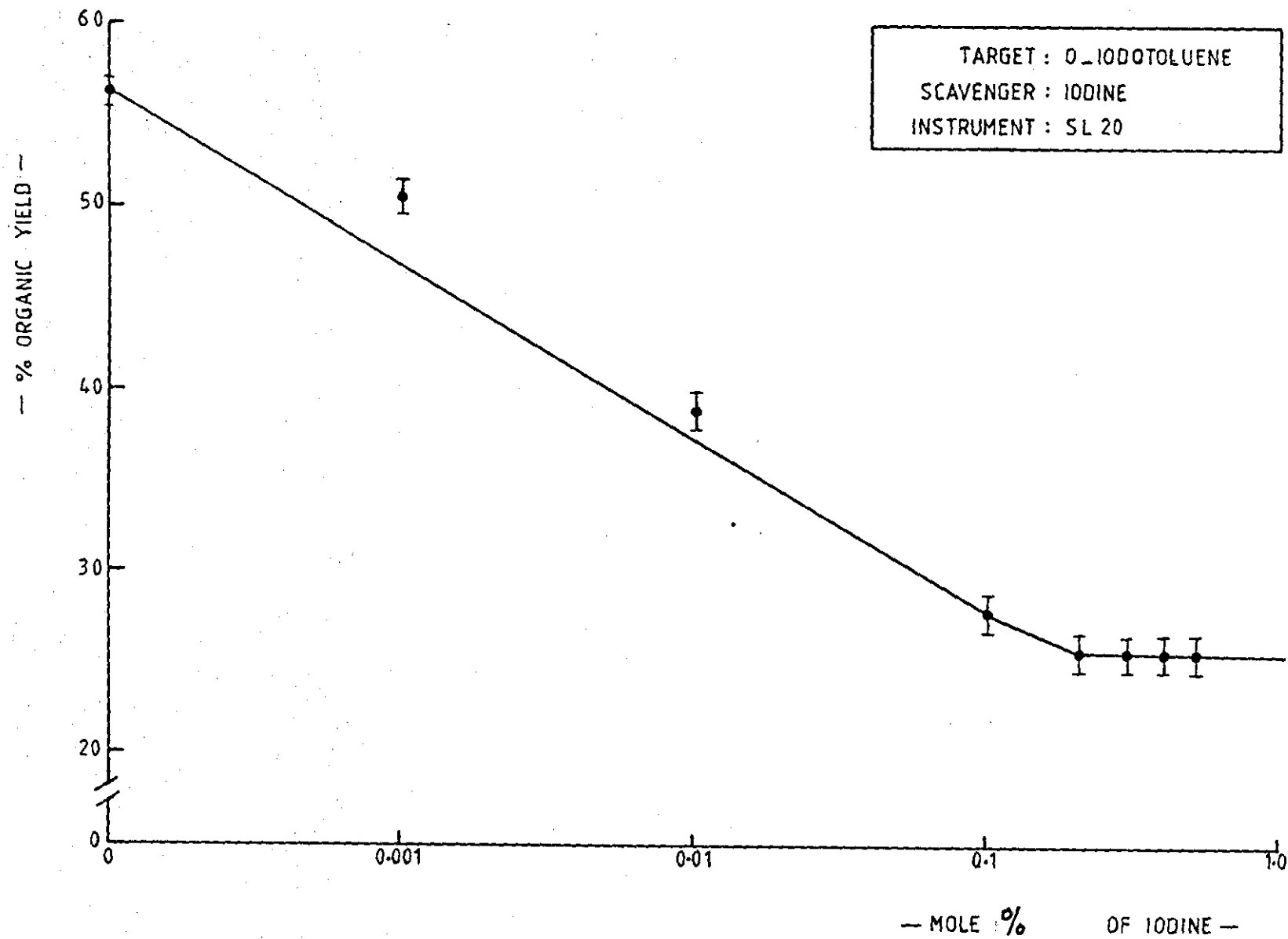

FIG.32. EFFECT OF IODINE ON THE ORGANIC YIELD.

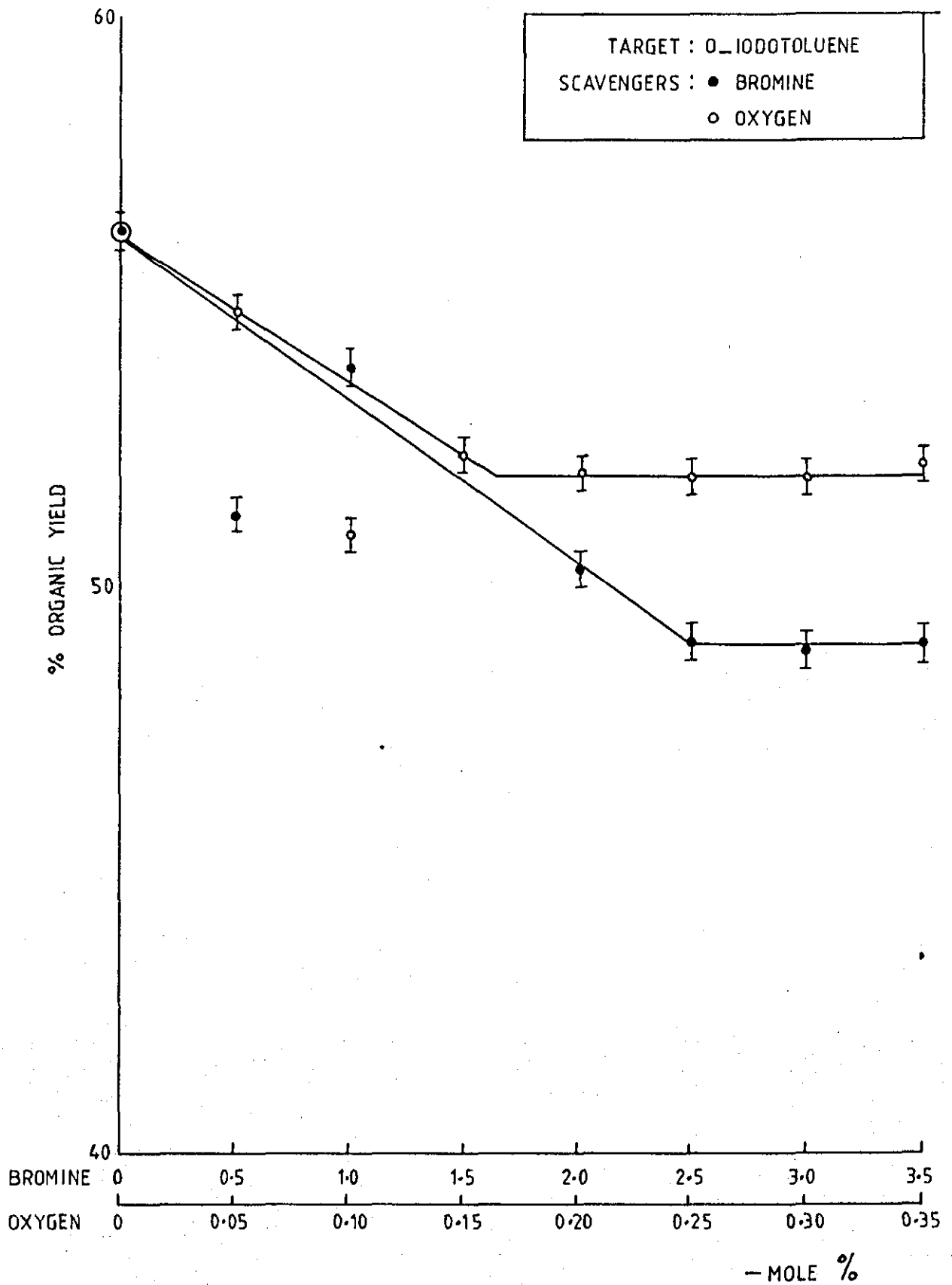

FIG. 33. EFFECT OF SCAVENGERS ON O-iodotoluene.

4.2 CAGING EFFECT

The distinction between hot and thermal processes is much more difficult to make in liquids than in gaseous systems. In part this is due to the practical difficulty of finding soluble scavengers. A more fundamental difficulty is presented by "Cage" reactions which are absent in gases. A cage process is a reaction sequence consisting of a collision in which the hot atom produces a radical (or other active species), which is trapped by the solvent in the same "Cage" as the atom. It becomes thermalized by collision with cage "walls" and then undergoes thermal combination with the radical. (43)

Such a process will be temperature independent and, since it involves only a few molecules, will not be affected by normal concentrations of scavengers. It is interesting to note that Cage-recombination models, rather than direct hot replacement, were long considered as the bases for theories of recoil atom combination in the liquid phase. (43)

The borderline between "Cage" and "true" hot combination reactions is difficult to establish not only experimentally but also in principle. In a "true" hot reaction the product is formed directly on impact, within the time span of one vibration. It is however, not noticeable that the product will be formed in a highly excited state and must be stabilized by immediate collisional energy transfer to survive. Such stabilization of an excited intermediate by collision with the cage walls, may not be distinguishable in any qualitative sense, from combination of a caged atom with a radical. It is probably most convenient to regard "cage" reactions as hot reactions, but recognizing that caging effects may make possible certain modes of hot reaction in liquid phase that are not possible in gases.

In the present study an attempt was made to further evaluate the effect of solvents, especially of "inert" solvents on the organic yield with respect to their effectiveness to scavenge thermal ^{128}I and ^{80}Br atoms in solvent cages.

For this purpose, liquid mixtures of o-iodotoluene, m-iodotoluene, o-bromotoluene and m-Bromotoluene with a variety of aliphatic and aromatic solvents with and without I_2 present as a scavenger^{were investigated.} These experiments should also provide us with additional insight into the details of the "hot" processes and allow us to assess the contribution made by radical-radical recombinations.

The results of these experiments are summarized in Tables (9 to 16).

These results show that the addition of 90 Mole % of aliphatic alcohols such as methanol, ethanol and n-Butanol, drastically reduce the yield.

The addition of 0.5 Mole % of I_2 scavenger to ortho and meta Bromotoluenes causes a further decrease in the organic yield (^{halved}), while the addition of this quantity of scavenger to the iodotoluene shows

little reduction in the organic yield. A somewhat different situation exists if the diluent is benzene or cyclohexane especially with bromotoluene (without I_2). In this case, a less dramatic reduction of the organic yield is observed.

TABLE 9EFFECT OF DILUENT ON THE ORGANIC YIELD OF o-BROMOTOLUENE(Without I₂ Scavenger)

System	Diluents	Diluent Mole %	% Organic Yield
			64.521
	-C6 H6	90	62.833
	-C6 H12	90	61.946
o-Bromotoluene	-CH3 OH	90	33.233
	-C2 H5 OH	90	32.086
	n-C4 H9 OH	90	29.026

TABLE 10EFFECT OF DILUENT ON THE ORGANIC YIELD OF o-BROMOTOLUENE(With 0.5 Mole % of I₂ Scavenger)

System	Diluent	Diluent Mole%	% Organic Yield
o-Bromotoluene + 0.5 Mole% of I ₂			62.436
	-C ₆ H ₆	90	47.213
	-C ₆ H ₁₂	90	46.861
	-CH ₃ OH	90	19.613
	-C ₂ H ₅ OH	90	18.346
	n-C ₄ H ₉ OH	90	16.600

TABLE 11EFFECT OF DILUENT ON THE ORGANIC YIELD OF m-BROMOTOLUENE(Without I₂ Scavenger)

System	Diluents	Diluent Mole%	% Organic Yield
			62.490
	-C6 H6	90	60.883
	-C6 H12	90	57.014
m-Bromotoluene	-CH3 OH	90	30.041
	-C2H5 OH	90	29.890
	n-C4 H9 OH	90	27.952

TABLE 12EFFECT OF DILUENT ON THE ORGANIC YIELD OF m-BROMOTOLUENE(With 0.5 Mole % of I₂ Scavenger)

System	Diluents	Diluent Mole%	% Organic Yield
m-Bromotoluene + 0.5 Mole% of I ₂			60.49
	-C6 H6	90	45.40
	-C6 H12	90	46.38
	-CH3 OH	90	18.47
	-C2 H5 OH	90	17.20
	-C4 H9 OH	90	16.01

EFFECT OF DILUENT ON THE ORGANIC YIELD OF *o*-IODOTOLUENE(Without I₂ Scavenger)

System	Diluents	Diluent Mole%	% Organic Yield
			58.47
	-CH ₃ OH	90	41.77
	-C ₂ H ₅ OH	90	38.89
<i>o</i> -Iodotoluene	n-C ₄ H ₉ OH	90	31.60
	-C ₆ H ₁₂	90	50.08
	-C ₆ H ₆	90	52.42
	-C ₆ F ₆	90	48.18
	-C ₆ H ₅ F	90	47.50

TABLE 14EFFECT OF DILUENT ON THE ORGANIC YIELD OF o-IODOTOLUENE(With 0.5 Mole % of I₂ Scavenger)

System	Diluents	Diluent Mole%	% Organic Yield
			47.96
	-CH ₃ OH	90	40.07
	-C ₂ H ₅ OH	90	37.83
	n-C ₄ H ₉ OH	90	29.81
o-Iodotoluene	-C ₆ H ₁₂	90	44.16
+			
0.5 Mole% of I ₂	-C ₆ H ₆	90	40.62
	-C ₆ F ₆	90	47.07
	-C ₆ H ₅ F	90	44.01

TABLE 15EFFECT OF DILUENT ON THE ORGANIC YIELD OF m-IODOTOLUENE(Without I₂ Scavenger)

System	Diluents	Diluent Mole%	% Organic Yield
			75.643
	-C6 H6	90	56.530
	-C6 H12	90	52.892
m-Iodotoluene	-CH3 OH	90	63.130
	-C2 H5 OH	90	59.050
	n-C4 H9 OH	90	45.493

TABLE 16

EFFECT OF DILUENT ON THE ORGANIC YIELD OF m-IODOTOLUENE(With 0.5 Mole % of I₂ Scavenger)

System	Diluents	Diluent Mole%	% Organic Yield
			66.836
	-C6 H6	90	48.340
m-Iodotoluene	-C6 H12	90	46.503
+			
0.5 Mole% of I ₂	-CH3 OH	90	58.773
	-C2 H5 OH	90	53.790
	-C4 H9 OH	90	39.873

4.3 THE SZILARD-CHALMERS EFFECT ON o-IODOTOLUENE

Hot atom chemistry had its beginning with the discovery of bond rupture of iodine-128 from neutron irradiated ethyl iodide by Szilard and Chalmers in 1934. Henceforth, because of favourable radioactivation properties, halogen reactions activated by radiative neutron capture in liquid aromatic systems became popular systems for study.

The purpose of this project is to investigate the organic products of the $^{127}\text{I}(n, \gamma) ^{128}\text{I}$ process in o-iodotoluene.

To do this the following experiments were performed;

- A. A mixture of o-iodotoluene, iodobenzene and petroleum ether (50 μl each) was prepared and 15 μl of this solution was injected into the GLC in order to check the separation.
- Two ml of o-iodotoluene was irradiated for 12 minutes. The irradiated sample was transferred into a 25 ml separating funnel containing 5 ml of 0.5 M sodium thiosulphate solution. The sample container (polyethylene vials of 1 ml volume) rinsed with petroleum ether, and the mixture was shaken for two minutes, and allowed to stand for two minutes. The organic layer (lower layer) was separated and then washed with 4 ml of tetrachloromethane and the washings separated. To 10 ml of petroleum ether in scintillation vials 50 μl from the organic layer and from the washings were added and 50 μl from the extract (aqueous layer) was added to 10 ml of distilled water and the three samples were counted.
- From the organic layer 5 μl was injected directly into the

FIGURE 34

15 μ l from the organic layer injected directly in the GLC

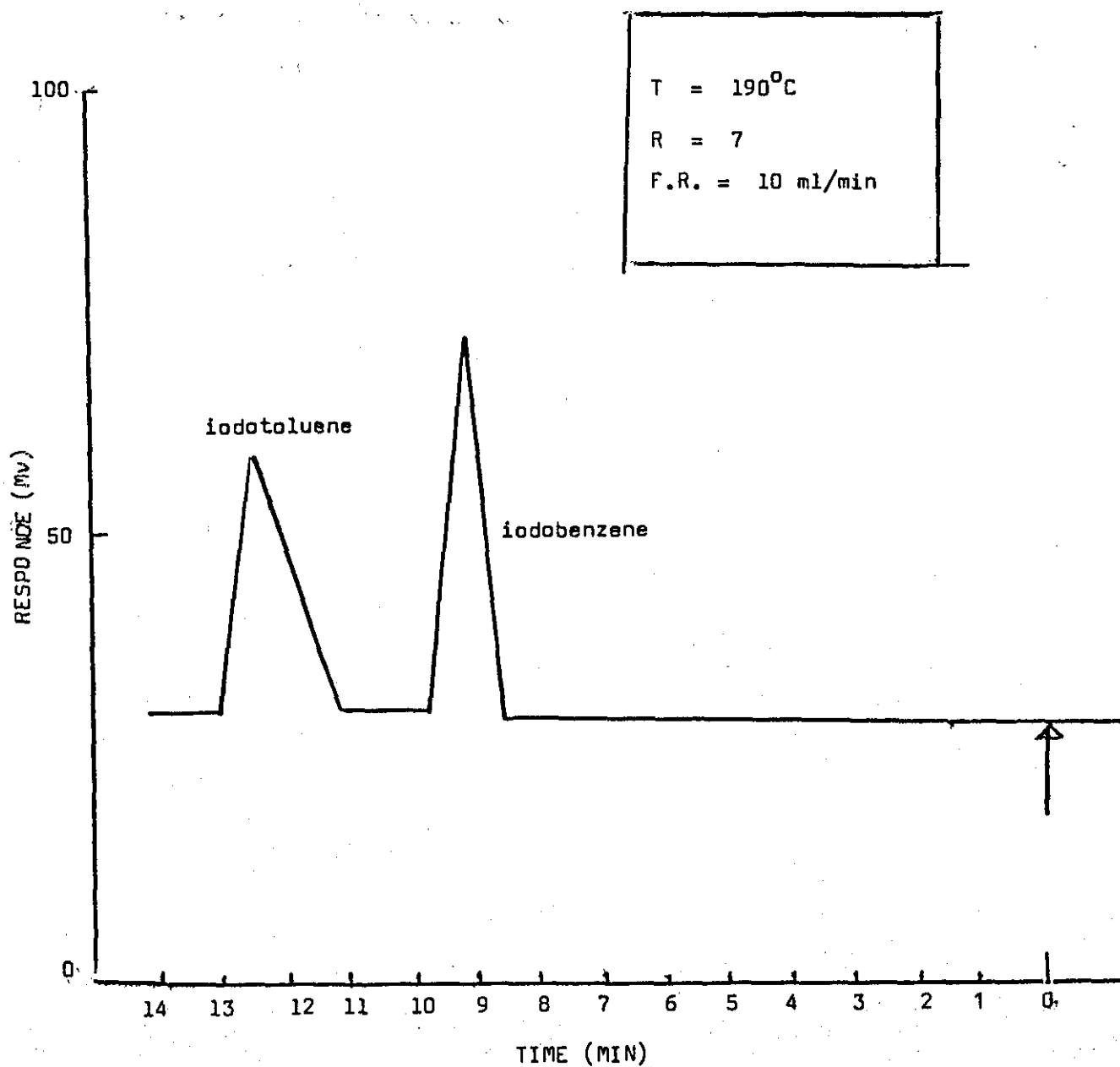
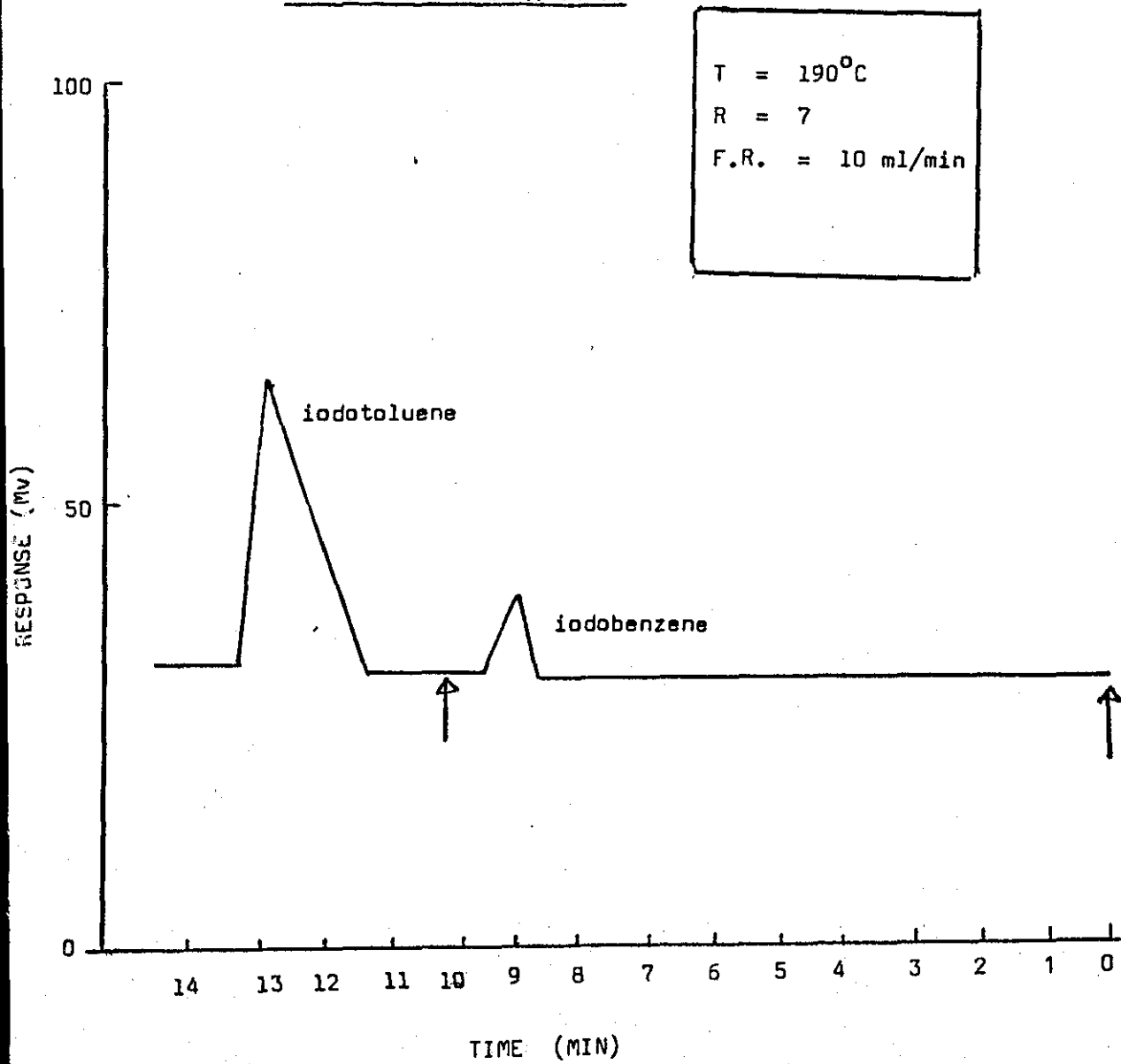

FIGURE 35

5 μ l from a mixture of organic (iodotoluene) layer
and iodobenzene in ether



GLC and the peak was collected and counted.

To 50 μ l of the irradiated *o*-iodotoluene 50 μ l of iodobenzene and 50 μ l of petroleum ether was added and from this mixture 15 μ l was injected into the GLC. The peaks were collected and the activity of each was counted. The results are shown in tables (17 and 18 and figures 34 and 35).

Table 17

The percent ORGANIC YIELD from Irradiation of 2 ml of *o*-IODOTOLUENE

Components	Time of irradiation	BF ₃ counts	cpm Corrected	% organic yield
Organic			6584	
Washings	632.5	1481535	731	75.64
Extract			2355	

Table 18THE ACTIVITY UNDER PEAKS COLLECTED FROM INJECTED SAMPLES OF:

- a) 5 μ l of ORGANIC LAYER
 b) 15 μ l of a MIXTURE of 50 μ l
 EACH (Iodobenzene + Iodotoluene in ether)

System	Time of irradiation	BF ₃ counts	cpm corrected
5 μ l of o-iodotoluene injected directly			120 \pm 10.9
15 μ l of the mixture (a) (b) of iodobenzene + iodotoluene	632.5	1481535	
A - peak 1			177 \pm 13.30
B - peak 2			153 \pm 12.36

B. To investigate the recovery of the activity of an irradiated sample, without the addition of iodine as a scavenger 2 ml of o-iodotoluene was irradiated in the neutron generator for 12 minutes and after extraction a 25 percent solution of the organic layer (iodotoluene), methanol and iodoethane was prepared from which 20 μ l were injected into the HPLC and the peaks collected and counted using a LKB Liquid Scintillation Counter.

Finally 20 μ l of the 25 percent solution were added to 5ml of the mobile phase (70% methanol + 30% distilled water), and counted results are shown in Table (19).

TABLE 19

RECOVERY OF THE ACTIVITY OF AN IRRADIATED SAMPLE

System	Time of irradiation	BF ₃ counts	Activity cpm
20 μ l of 25% solution of I.T. + I.E, and Methanol in 5 ml of mobile phase	597.1	348761	496 \pm 22
20 μ l of 25% sol.			
iodoethane - peak 1			133 \pm 11.53
iodotoluene - peak 2			368 \pm 19.18

C. To investigate the effect of solvent on the counting efficiency and the number of counts (activity) 2 ml of *o*-iodotoluene was irradiated for 12 minutes and 20 μ l from the irradiated sample was added to:

- i) 8 ml of the mobile phase (70 percent methanol + 30 percent distilled water)
- ii) 8 ml of petroleum ether

and the above two samples were counted.

Then the procedure in (B) was repeated to check the recovery of the activity. The results are shown in Table (20).

TABLE 20

EFFECT OF SOLVENTS ON COUNTING EFFICIENCY

System	Time of irradiation	BF ₃ counts	Activity cpm corrected
20 μ l in 8 ml of the mobile phase			1757 \pm 41.9
20 μ l in 8 ml of petroleum ether			1919 \pm 43.8
	570 sec	569982	
iodoethane (peak 2)			120 \pm 10.95
iodotoluene			342 \pm 18.49
20 μ l in 5 ml of the mobile phase			496 \pm 21.65

The above results (Table 20) show that when the solvent is petroleum ether the counting efficiency is slightly higher than that when the solvent is the mobile phase. The activity of iodoethane was 25.58 percent and that of iodotoluene 72.92 percent. From these results and those from procedure (B) we can conclude that there is almost complete recovery of activity.

- D. From an irradiated sample of *o*-iodotoluene 20 μ l were added to 7 ml of (methanol-water) solution and counted. Then a 25 percent solution of iodoethane and irradiated *o*-iodotoluene in methanol was prepared from which 20 μ l were injected into the HPLC and the first peak was collected for 7 min. The second peak was collected for 13 min. and then counted. Finally in order to check the variation of number of counts with the volume of solvent 20 μ l of the 25 percent solution were added to:

- i) 7 ml of (70% methanol - 30% water)
 ii) 13 ml of (70% methanol - 30% water)
 and counted. The results are shown in Table 21.

TABLE 21Variation of Number of Counts with Volume using 25 percent solution

System	Time of irradiation sec	BF ₃ counts	cpm
20 μ l o-iodotoluene in in 7ml of (methanol- water) solution			3080 \pm 55.49
20 μ l of 25% solution in 7ml of (methanol-water) solution			1360 \pm 36.88
	588	840920	
20 μ l of 25% solution in 13 ml of (methanol-water) solution			1498 \pm 38.7
iodoethane (peak 1)			642 \pm 25.33
iodotoluene (peak 2)			739 \pm 27.18

- E. The same procedure (D) was used for a 15 percent solution instead of the 25 percent solution and the results are shown below in Table (22) and Figure (36).

TABLE 22

Variation of Number of Counts With Volume Using 15 Percent Solution

System	Time of irradiation	BF ₃ counts	cpm
Background			29.00
20 μ l σ -iodotoluene in 7 ml of (methanol- water) solution.			4418 \pm 66.4
20 μ l of 15% solution in 7 ml of (methanol-water) solution.	721.7	1272653	1087 \pm 32.97
20 μ l of 15% solution in 13 ml of (methanol-water) solution.			929 \pm 30.39
Activity of iodoethane (peak 1)			158 \pm 12.56
Activity of iodotoluene (peak 2)			670 \pm 26.0

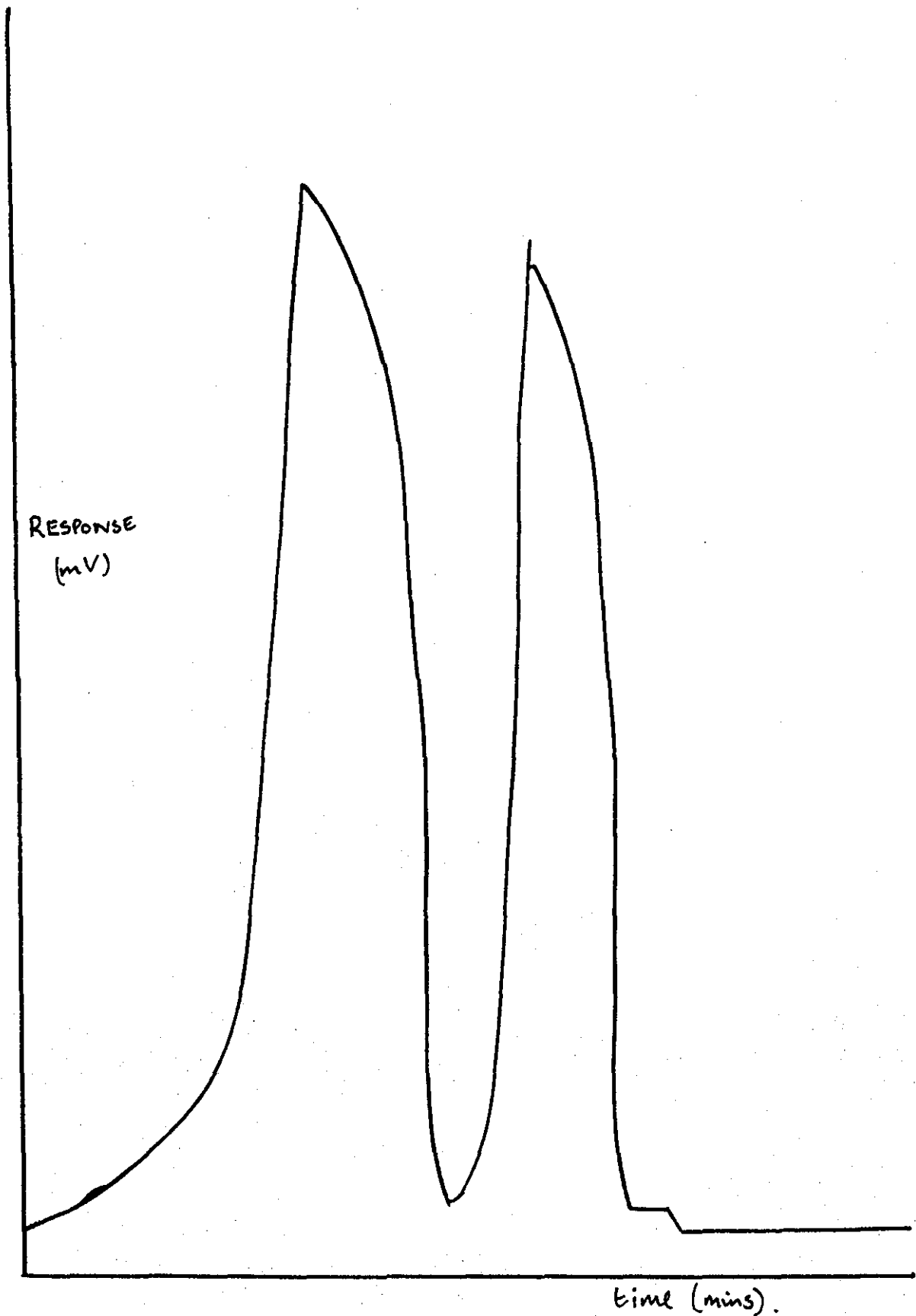

FIGURE 36. 20 μ l of 15 percent solution of Iodoethane +
Iodobenzene in Methanol

TABLE 23

Variation of Number of Counts With Volume Using 15 Percent Solution

System	Time of irradiation sec	BF ₃ counts	cpm
20 μ l of o-iodotoluene in 5 ml (70% methanol- 30%water) solution			2396 \pm 48.94
7 " " "			2377 \pm 48.75
9 " " "			2492 \pm 49.91
11 " " "	724.7	1242793	2656 \pm 51.53
13 " " "			2297 \pm 47.92
15 " " "			2272 \pm 47.66
17 " " "			2407 \pm 49.06
19 " " "			2142 \pm 46.28
20 μ l of 15% solution in 7 ml (methanol - water)			2984 \pm 57.62
20 μ l of 15% solution in 13 ml (methanol- water)			2500 \pm 50.00
Activity of iodoethane (peak 1)			259 \pm 16.09
Activity of o-iodoto- luene. (peak 2)			781 \pm 27.94

TABLE 24

System	Time of irradiation sec	BF ₃ counts	cpm
20 μ l of o-iodotoluene in 10 ml of (70% meth- anol-30% water) solut- ion. Counted repeatedly every 2 min.			
1			2793 \pm 52.84
2			2848 \pm 53.36
3			2729 \pm 52.23
4	724.7	1242793	2883 \pm 53.69
5			2613 \pm 51.11
6			2468 \pm 49.67
7			2372 \pm 48.70
8			2574 \pm 50.73
9			2462 \pm 49.61
10			2289 \pm 47.84
11			2250 \pm 47.43
12			2182 \pm 46.71
13			2350 \pm 48.47
14			2145 \pm 46.31
15			2168 \pm 46.56
16			2152 \pm 46.38

VARIATION OF NUMBER OF COUNTS WITH TIME

F. To check whether the activity from peak 1 (iodoethane) was due to elementary iodine, 2 ml of *o*-iodotoluene were irradiated for 12 min. and then washed with 6ml of 0.1 M of sodium thiosulfate solution and the previous procedure employed. To check the variation of number of counts with volume 20 μ l of the irradiated and washed sample of *o*-iodotoluene were added to 5, 7, 9, 11, 13, 15, 17 and 19 ml (70% methanol - 30% water) solution and counted. Finally 20 μ l of the irradiated sample were added to 10 ml of (70% methanol - 30% water) solution and counted repeatedly. The results are shown in Tables (23 and 24).

G. 2 ml of *o*-iodotoluene was irradiated for 12 minutes and then extracted and washed. 200 μ l of each component (organic, washings and extract) was added to 10 ml of hexane and counted and the results are shown in Table 25.

TABLE 25

Organic Yield from Irradiated *o*-Iodotoluene

Component	BF ₃ counts	Time of irradiation sec	cpm	% organic Yield
Organic			11377 \pm 106.6	
Washings			802 \pm 28	
Extract	1204941	724.2	2360 \pm 48.5	83%
200 μ l of 15% solution in 10 ml of hexane			1876 \pm 43.3	

200 μ l of a solution containing 15% of organic layer and 15% of iodobenzene in hexane was injected into the GLC and the column effluent was passed through 10 ml of hexane contained in a glass pot. After two minutes collection time, the pot was replaced by another pot containing fresh hexane and the column effluent allowed to pass through the fresh hexane for a further two minutes. The replacement procedure was repeated for twenty different pots making a total collection time of forty minutes. Each portion of hexane was made up to 10 ml with hexane and the twenty samples were counted. The results are shown in Table 26.

- H. From an irradiated sample of *o*-iodotoluene 50 μ l was added before extraction to 10 ml of hexane and the solution was counted.

After extraction 1 ml of the organic layer was added to 1 ml of iodobenzene and 50 μ l from this mixture added to 10 ml of hexane and counted. From the above mixture (1 ml iodobenzene + 1 ml of organic layer) 50 μ l were injected into the GLC and the collection of the effluent from the column started when the iodoetoluene peak appeared on the recorder. The collection time was 10 minutes and the solution then made up to 10 ml with hexane and counted. The results are as shown in Table 27.

TABLE 26

Activity From 2 Minutes G.L.C. Sample of 15 Percent Solution

Sample No.	Time after injection (min)	cpm	% Activity	Total of % activity
1	2	33 ± 5.74	1.75	
2	4	64 ± 8.0	3.41	
3	6	50 ± 7.70	2.66	
4	8	56 ± 7.48	2.89	
5	10	70 ± 8.36	3.73	
6	12	66 ± 8.12	3.51	
7	14	43 ± 6.55	2.29	
8	16	37 ± 6.08	1.97	83%
9	18	34 ± 5.83	1.81	
10	20	41 ± 6.40	2.18	
11	22	121 ± 11.0	6.44	
12	24	251 ± 15.89	13.37	
13	26	81 ± 9.0	4.31	
14	28	103 ± 10.14	5.49	
15	30	72 ± 8.48	3.83	
16	32	96 ± 9.79	5.11	
17	34	61 ± 7.81	3.25	
18	36	71 ± 8.42	3.78	
19	38	83 ± 9.11	4.42	
20	40	120 ± 10.95	6.39	

TABLE 27

System	cpm
50 μ l of irradiated sample in 10 ml hexane	4171 \pm 64.58
50 μ l of mixture in 10 ml hexane	1097 \pm 33.12
Activity under iodotoluene peak	222 \pm 14.89

ACTIVITY OF IRRADIATED SAMPLE OF σ -IODOTOLUENE BEFORE
AND AFTER EXTRACTION

CHAPTER 5DISCUSSION

The scavenger effects, caging effects and the Szilard-Chalmers effects play an important role in liquid hot atom chemistry.

In this work, an attempt was made to investigate the above effects. Since radioisotopes of short half-life (iodine-128 and bromine-80) were studied, special care was taken to ensure that the separation and analysis were rapid.

5.1 Scavenger Effects

The effect of the addition of radical scavenger, prior to neutron irradiation of a halogen containing organic compound, on the activity of the organic yield is shown in tables (5, 6, 7 and 8) and figures 29, 30, 31, 32 and 33). For the purpose of discussion, these results may be divided into two sections. Firstly, a comparison of the efficiency of different scavengers and secondly, the effect of increasing the concentration of added scavenger. The results in the above tables show that the addition of 10^{-1} mole per cent of I_2 reduced the total organic yield from 56 to 27 percent, whereas the addition of 10^{-1} mole % of pyridine or bromine only reduced the yield from 56 to 50%. A similar small reduction is found with the addition of 10^{-1} mole % oxygen (56 to 51%). These results indicate that I_2 is a better scavenger than the others.

The results shown in the graphs of organic yield against increasing concentration of added scavenger (Figures 29 - 33) may be divided into two parts, the division depending upon the slope of the graph i.e. the rate of decrease of organic yield with increase in concentration of added scavenger. The organic yield is extremely sensitive to small quantities of halogen added to the system before neutron irradiation and, in this study, it is found that the organic yield is approximately halved by the addition of 0.001 to 0.5 molar fraction of iodine. J.E.C. Macrae and P.F.D. Shaw (14) in 1962 showed that the organic yield fell extremely rapidly when the scavenger (iodine) concentration was increased from 0 to 0.05 molar fraction.

It has been found in this study that further increase in concentration of the iodine scavenger causes relatively little reduction in organic yield, which for several iodides shows an approximately linear decrease to Zero as the halogen concentration is increased. This was found to be in agreement with J.E.C. Macrae and P.F.D. Shaw (14) who found that further increase in the concentration of iodine still caused a reduction in organic yield, but the rate of decrease of the yield was reduced. The observation has been explained by Willard et al (2) who postulated that one of the processes leading to the formation of organically bound radio-iodine was the thermal combination of radicals produced by the capture event with the radio-iodine atoms. If such a combination involves the diffusion of the reacting species, small concentrations of iodine can intercept and react with the radicals, so decreasing the chance of their

reaction with the active atoms. In most cases investigated, the diffusion-controlled reactions have been shown to lead to the formation of the parent compound (14). For example Levey and Willard (101) have shown that the fall in the organic yield when small quantities of iodine are added to methyl iodide is balanced by the reduction in activity of the active methyl iodide present, over the same range of iodine concentration. The activity of other species produced, for example methylene iodide, was unaffected within experimental error. As the concentration of scavengers used in this study is increased, the organic yield becomes less sensitive to the scavenger concentration variation, and this less sensitive part of the organic yield is regarded as arising from recombination or replacement reactions which do not involve diffusive processes (14), and may be termed "hot" since presumably a considerable amount of energy from the capture event may still be available in the radio-iodine atom or the surrounding molecules. In summary, the irradiation of a liquid organic halide allows about half of the radiohalide to be extracted into an aqueous solution (102) and the organic yield is dependent on the presence of free iodine in the irradiated iodide, and falls extremely rapidly when the iodine concentration is increased. Further increase in iodine concentration still causes a reduction in the organic yield, but the rate of decrease in organic yield is reduced.

5.2 Caging Effect

Iodine - 128 and bromine - 80 produced from $I^{127} (\alpha, \gamma) I^{128}$ and $Br^{79} (\alpha, \gamma) Br^{80}$ nuclear reactions were used to study Br or H substitution in purified liquid ortho and meta iodotoluene and, ortho and meta bromotoluene. The compounds were studied with and without I_2 present as radical scavenger. In addition, highly diluted mixtures of these compounds with a variety of organic solvents, such as simple aliphatic hydrocarbons, aromatic and perfluorinated aliphatics and aromatics were studied.

The results obtained in these systems suggest an interaction between the molecules making up the solvent cage with the intermediates forming the substituted product. This interaction consists most likely of an H abstraction by the I radical in the solvent cage, which competes with the reactions of thermal iodine leading to the I - 128 - substitution products, resulting in reduced organic yields of the latter compound. In the cases of the unreactive wall molecules, e.g. perfluorinated hydrocarbons, such a reaction cannot take place and the yields of the I^{128} substitution products remain large.

Stocklin et al (38) more recently suggested that chlorination of monosubstituted benzene in the liquid phase following $Cl^{37} (\alpha, \gamma) Cl^{38}$ reaction occurs via two processes: a one-step reaction being first order with respect to the concentration of the aromatic substrate and multistep process involving at least two substrate molecules. They further postulate that both mechanisms involve complex formation. The one-step reaction proceeds via direct addition of the I^{128} to the aromatic substrate forming a σ - complex. The multistep

process, on the other hand, may involve, according to these authors, a π - to σ - complex reaction sequence. The initial π - complex formed by the interaction of the kinetically excited I^{128} atom with the aromatic substrate may rearrange to a σ - complex and eventually lead to I^{128} substitution or in a competing process a scavenger, alcohol, or alkane, may extract I^{128} from the complex. Thus the addition of alcohol or alkane effectively suppresses the σ - complex formation. These compounds should also scavenge, via hydrogen abstraction, thermal I - 128 atoms, which in the case of exothermic reactions can replace substituents in the aromatic substrates. It has been assumed that in addition to the "self-scavenging" of the I - 128 by the hydrogen containing solvents, the solvent molecules also participate indirectly in the substitution process by providing a different "cage environment" in each case, leading to a more or less effective caged radical-radical recombination. In the present study an attempt has been made to further evaluate the effect of solvents, especially of "inert" solvents, such as perfluorinated hydrocarbons with respect to their effectiveness to scavenge thermal I - 128 atoms in solvent cages and to extract I^{128} atoms from the postulated intermediate σ - complex. For this purpose the I^{128} substitution following I^{127} (α, γ) I^{128} reaction was investigated using liquid mixtures of o -, m - iodo-toluene and o -, m - bromotoluene with a variety of aliphatic and aromatic solvents with and without I_2 scavenger. The results of these experiments are summarized in tables (9 - 16) which show that the addition of 90 mole % of cyclohexane or aliphatic alcohols such as methanol, ethanol and n-butanol, reduce the organic yield. Tables (9, 10, 11 and 12) show that when 90 mole% of the diluents are added to ortho and meta bromotoluene without adding I_2 as scavenger will cause a reduction in the organic yield

In the case of alcohols as diluents the reduction of the organic

yield was found to be lower when the number of Carbons in the alcohol molecules increase (i.e. the yield was higher with CH_3OH than with $\text{C}_2\text{H}_5\text{OH}$..etc).

The addition of 0.5 mole % of I_2 as a scavenger to the system before neutron irradiation causes a reduction in the organic yield of about 15%. When aliphatic alcohols, benzene, Cyclohexane and perfluorinated hydrocarbons are added to ortho or meta iodotoluene (with or without the addition of scavenger before irradiation) they will cause a less dramatic reduction in the organic yield than that noticed in bromotoluene. Stoklin (38) indicated, as evidenced by the identical yield of 1.3% Cl^{38} dichlorobenzene in the case of o-dichlorobenzene -cyclohexane with or without 0.5 mole % I_2 scavenger present, that this decrease in the radiochemical yield of the substitution product is not affected by the presence of small amounts of I_2 scavenger.

A somewhat different situation exists if the diluent is benzene. In this case, a less dramatic reduction of the I - 128 - for - I substitution yield is observed. The effect of aliphatic hydrocarbons and alcohols can be understood by considering the relatively high reactivity of these compounds towards thermal iodine and bromine atoms. Consequently by surrounding the iodotoluene and iodobromine molecules with these compounds the probability of recombination between the (thermalized) I and Br atom with the iodophenyl or the bromophenyl radical is greatly decreased since the phenyl radicals have now to compete with the solvent molecules for I or Br atoms. The results in tables (9 - 16) suggest that benzene is a less reactive partner ^{than the other diluents} for thermal I and Br atoms.

This is because the H abstraction reaction with I and the H substitution reaction with Br are both endothermic reactions.

Radical recombination or π - complex formation leading to the substitution product is therefore possible in the unscavenged system. The effect of the iodine concentration in the pure solvents as well as with iodobromine and iodotoluene in various diluents were studied. It appears that the reaction of iodine with pure iodo and bromotoluenes is different to the reaction of iodine with diluted compounds. This suggests that during the neutron irradiation a range of iodo-compounds are formed, of which, the concentration of one species decreases with increase in iodine concentration. In (α , γ) reactions, one usually assumes the formation of free radicals or charged fragments. However, the reactivities of free radicals are expected to be the same for these substances and should more or less be independent of the diluent used.

In summary, the irradiation of a dilute solution of an organic halide in an organic solvent reduces the fraction of the radiohalide found in the parent molecule to zero as the concentration is decreased (103) but in this study, it has been noticed that the decrease of that fraction was about 33%. The results obtained in these systems suggest an interaction between the molecules making up the solvent cage with the intermediates forming the products. This interaction consists most likely of a hydrogen abstraction by the halogen radical in the solvent cage, which competes with the reactions of thermal halogen leading to the formation of I - 128 and Br - 80 substitution products, resulting in reducing the organic yield of the latter compounds. In the case of perfluorinated hydrocarbons such a reaction cannot take place because the perfluorinated hydrocarbons are known as unreactive wall molecules, thus the yield of I - 128 products remain large. The use of benzene as a diluent is less efficient in reducing the organic yield than are aliphatic compounds which may be due to the fact that benzene forms a π - complex which in terms of the caged radical-radical it cannot remove I - 128 and Br - 80 radicals and may be only by π - complex formation.

5.3 Szilard-Chalmers Effects

Most studies of the Szilard-Chalmers effects in organic halides have been made with pure halides either alone or mixed with free halogen.

When organic iodides are irradiated with neutrons they undergo the Szilard-Chalmers reaction in which part of the radio-iodine produced by neutron capture is found in organic, and part in inorganic combination. The nature of the primary event responsible for the disruption of the parent molecule is still obscure, but the diversity of new organic species produced indicates that a considerable energy from the neutron capture event is available for the chemical disruption of the neighbouring molecules.

Bodo Diehn and V. George Thomas (19) in a recent study reported that the product-spectrum generated upon X-irradiation of iodobenzene consisted of the following compounds: benzene, iodine, iodobenzene, o -, m -, and iodobiphenyls. In this study the expected compounds generated upon neutron irradiation of a purified sample of o - iodotoluene may include the above compounds. In addition any of the following compounds could be formed: iodotoluenes, benzyl iodide (which might be formed from labelling of the methyl group attached to the benzene ring with iodine), 1, 2 and 3 iodo benzyl iodides and a variety of aliphatic iodocompounds which might be formed due to the disruption of the benzene ring upon neutron irradiation. Unfortunately it was difficult to detect the expected compounds (except the parent compound i.e. o - iodotoluene) because the GLC was not sensitive enough to detect the above compounds especially those which were formed in trace amounts.

Some insight into the processes occurring after neutron capture can be obtained from the "scavenger" effect, or the fall in the organic yield observed when a radical scavenger, such as elementary iodine, is present during the irradiation.

The general procedure, as described previously, was to irradiate a 2 ml sample of the purified *o*-iodotoluene for 12 minutes and extract with a dilute aqueous solution of sodium thiosulphate and then separate the aqueous layer from the organic layer.

To investigate the activity recovered after separating the components within a sample, a mixture was injected into the HPLC or the GLC. For this purpose 20 μ l of 25% solution of *o*-iodotoluene, iodoethane and methanol in 5 ml of the mobile phase were injected onto the HPLC column. The results shown in table (19) demonstrate that the activity recovered after separation was very high (99.2%). The activity was determined by Cerenkov counting and the counting efficiency was found to be influenced by many factors such as the kind of solvent, the volume of solvent, the concentration of the solution (15% and 25% were used) and the total volume of the solution to be counted. The optimum total volume was found to be between 9 and 11 ml. The results shown in table (26) show that when 200 μ l of a mixture of 15% each of *o*-iodotoluene and iodobenzene in hexane injected into the GLC, 83% of the injected material was collected in $20 \times 10 \text{ cm}^3$ fractions of hexane (total collection time of 40 minutes). The organic yield of the parent compound is 58.63%, the remainder might be the other species produced from the neutron capture. The above experiment was repeated many times (twenty runs) under the same experimental conditions because some of the obtained results were not consistent. This was probably due to the following factors:

1. Leak problems in the GLC
2. Some difficulties in controlling the heat

3. The purity of the materials used, this is of great importance since the irradiation is very sensitive to the presence of impurities even if they are in trace amounts.
4. Iodine compounds undergo photolytic decomposition when exposed to light. For this reason care was taken to prevent, or at least to minimise, this by wrapping the container with dark paper and storing the compound in the dark. However, there is still some doubt about the complete prevention of this decomposition because each run takes about 50 minutes in day light or Neon light.
5. Variation in injection volume
6. During the collection of the column effluent, in pots containing 10 ml of hexane it was observed that the solution evaporated and the evaporated quantities were found to be different from one pot to another as well as from one run to another. To eliminate this variation, the samples were remade up to 10 ml with fresh hexane before counting the activity collected.
7. The exposure of the sample to the light causes fluorescence which results in an increase in the number of counts recorded by the liquid scintillation counter. To overcome this effect the samples were counted repeatedly and the results were corrected for decay time.

CONCLUSIONS

The objectives of this work were to investigate,

- (i) scavenger effects on o-iodotoluene.
- (ii) the caging effects on scavenged and unscavenged systems of iodotoluenes and bromotoluenes with a variety of inert diluents, and
- (iii) some Szilard-Chalmers effects on o-iodotoluene

It has been found that organic yield is significantly influenced by the presence of iodine scavenger, the total organic yield being reduced from 56 to 27% by 10^{-1} mole percent of I_2 . Pyridine, bromine and oxygen were found to have smaller effects.

The effect of dilution with aliphatic and aromatic solvents on the radiochemical yield of labelled ortho and meta iodotoluene and bromotoluene shows that the addition of aliphatic hydrocarbon or alcohol drastically decreases the yield.

The experiments to investigate the Szilard-Chalmers effect were inconclusive as the separation and detection methods employed proved to be inadequate in identifying trace amounts of possible activation products.

REFERENCES

1. J.E. Willard in "Chemical Effects of Nuclear Transformations", Vol. II, p 216-227, I.A.E.A. Vienna (1961)
2. J.E. Willard, Ann. Rev. Nuc. Sci., 3 193 (1953)
3. J.E. Willard, "Chemical Effects of Nuclear Transformations", Vol. I, p. 221, I.A.E.A., Vienna (1965)
4. A.P. Wolf, Ann. Rev. Nuc. Sci., 10 259 (1960)
5. A Suida, Chem Effects of Nuc. Trans., Polish Atomic Energy Commision, Warsaw (1963)
6. I.G. Campbell, Adv. In Inorg and radiochem., Vol V, p.135, Academic Press, New York (1963)
7. A.A. Gordus and C.J. Hsuing, J. Chem. Phys., 36, 954 (1962).
8. A.A. Gordus and J.E. Willard, J. Am. Chem. Soc., 79, 4609 (1957)
9. S. Wexler and .T.H. Davies, J. Chem. Phys., 20, 1683 (1952)
10. J.E. Sturm and D.G. Davis, paper No. 106, Am. Chem Soc. (1961)
11. A. Rex, Z. Physik. Chem., 55, 355 (1906)
12. R.M. Iyer and G. Martin, Chem. Effects of Nuc., Trans., Vol. I p. 282, I.A.E.A. Vienna (1961).
13. H.M. Chang and J.E. Willard, J. Phys. Chem. 71, 3576 (1967)
14. J.E.C. McCrae and P.F.D. Shaw, J. of Inorg. and Nuc Chem., 24, 1337 (1962)
15. P.R. Geissler and J.E. Willard, J. Phys. Chem. 67, 1675, (1963)
16. .T.A. Carlson and .R.M. White, Chem Effects of Nuc. Trans., Vol. I, p. 23, I.A.E.A., (1965)
17. M.L. Perlman and J.A. Miskel, Phys. Rev. 91, 899 (1953)
18. J.K. Thomas, in "Proceedings of the second Tohany Symposium on Radiation Chemistry", p. 115, Hungarian Academy of Science, Budapest (1967)
19. Bodo Diehn and V. George Thomas. J. Phys. Chem., Vol. 76, No. 18 (1972)
20. Hartman and Meyer, Ber. 1894, 27, 502
21. J.E.C. McCrae and P.F.D. Shaw. J. Inorg. Nuc. Chem., Vol. 24, 1327 (1962).

22. Wilkey D. Dennis (Reaction of dil. aq. CH_3I)
23. E.J. Kemnitz. PhD Thesis, University of Nebraska, Lincoln, Nebraska, U.S.A., 1971 (Microfilm 71-1949s)
24. C.E. McCauley and R.H. Schuler, J. Phys. Chem., 1958, 62, 1364
25. D.J. Malcolm-Lawes, PhD. Thesis 1969
26. R. Wolfgang, Progress in Reaction Kinetics (1963)
27. J.E. Willard. et al. *ibid*, 20, 1556, (1952)
28. R.J. Carter, W.H. Hamil and R.R. Williams. J. Amer. Chem. Soc., 74, 6007, (1952)
29. P.J. Estrup and R. Wolfgang, J. Amer., Chem. Soc., 82, 2666, (1960)
30. P.J. Estrup and R. Wolfgang, J. Phys. Chem., 62, 1356, (1958)
31. Fox and Libby, J. Chem. Phys., 1952, 20, 487
32. Rowland and Libby, *ibid.*, 1953, 21, 1495
33. Capron and Crevecoeur, J. Chem. Phys. 1952, 49, 29
34. Capron and Oshima, J. Chem. Phys. 1952, 20, 1403
35. Capron and Crevecoeur, *ibid.*, 1953, 21, 1843
36. Chien and Willard, J. Amer. Chem. Soc., 1954, 76, 4735
37. Shaw and Collie, J., 1951, 434
38. Klara Berei and G. Stocklin, Radio-Chemica Acta. 1971, 15, 39-46
39. G. Levey and J.E. Willard, J. Am. Chem. Soc., 74, 6161
40. T. Brustad and J. Baarli, J. Chem. Phys. 22, 1311, 1954
41. M. Milman and P.F.D. Shaw, J. Chem. Soc., 1303, 1310, 1317 (1957)
42. B. Knight, G.E. Miller and P.D.F. Shaw, J. Inorg. Nucl. Chem. 23, 15, (1961)
43. W.F. Libby, J. Am. Chem. Soc. 69, 2523 (1947)
44. J.M. Miller and R.W. Dodson, J. Chem. Phys. 18, 865 (1950)
45. S. Aditya and J.E. Willard, J. Am. Chem. Soc., 79, 3367 (1957)
46. M. Milman, Radiochim. Acta 1, 15, (1962)

47. S. Wexler and G.R. Anderson, *J. Chem. Phys.* 33, 850 (1960)
48. Talrose, V.L., *Pure and Applied Chemistry*, 5, 455, (1962)
49. Fite, W.L. and Datz, S., *Ann. Rev. of Phys. Chem.* 14, 61, (1963)
50. R. Wolfgang., *Progress in Reaction Kinetics*. Vol. 3, 105, (1965)
51. Wexler, S., *Actions Chimiques et Biologiques des Radiations*, ed. by Haissensky, M., Massion et cie (Paris)
52. Allison, L.K. and Garcia-Munoz, M., *Atomic and Molecular Process*, ed. by Bates, D.R., Academic Press, p.722, 1962
53. Campbell, I.G., *Advances in Inorganic Chemistry and Radiochemistry*, 5, 135, (1963)
54. Willard, J.E., *Ann. Rev. Phys. Chem.* 6, 141, 1955
55. Aten, A.H.W., J.R., Kock, B. and Kommandeur, I., *J. Am. Chem. Soc.*, 77, 5498, 1955
56. Anbar, M. and Neta, P., *J. Am. Chem. Soc.*, 84, 2673, 1962
57. Colebourne, N. and Wolfgang, R., *J. Chem. Phys.*, 38, 2782, 1963
58. Rack, E.P. and Gordus A.A., *J. Chem. Phys.* 34, 1855, 1961
59. Milman, M., *Radiochem. Acta*, 2, 180, 1964
60. Cross, R.J. and Wolfgang, R., *Radiochem. Acta*, 3, 112, 1964
61. J.T. Prud'homme: *Texas Nuclear Neutron Generators* (1964)
62. J.P. Cali et al., *Proceedings of the 1965 International Conference on Modern Trends in Activation Analysis*, Collage Station, Texas (U.S.A.) pp. 253-257
63. K.G. Darral and G. Oldham. *Nuclear energy*, pp. 189-194 (July-August 1966).
64. *Gas - Liquid Chromatography, Theory and Practice*. Stephen Dal Nogarc and Richard S. Juvet, Jr. (1962)
65. Birks, J.B., *The theory and practice of Scintillation Counting*, Pergamon Press, London (1967)
66. Bell, G.B., Hayes F.N., *Liquid Scintillation Counting*, Pergamon Press, Oxford (1957)
67. D. Ormond and F.S. Rowland, *J. Amer. Chem. Soc.*, 1961, 83, 1006
68. J. Vernois, A. Abdel-Ghani, R. Muxart and Arapaki-Strapelias, *7th International Hot Atom Symposium Jilich*, 1973, p 75
69. A. Halpern and R. Sochacka, *J. Inorg. Nuclear Chem.* 1961, 23, 7.

70. J.E.C. McCrae and P.F.D. Shaw, *J. Inorg. Nuclear Chem.*, 1962, 24, 1327
71. O.H. Wheeler and C. Lecumberry, *Radiochem. Acta*, 1970, 14, 119
72. F. Baumgartner, I.A.E.A. Vienna, 1965, 507
73. N. Colebourne, J.F.J. Todd, and R. Wolfgang. I.A.E.A. Vienna 1965, 149
74. R.L. Williams and F.S. Rowland, *J. Phys. Chem.*, 1972, 76, 3509
75. Y.N. Tang, and F.S. Rowland, *J. Phys. Chem.*, 1967, 71, 4576
76. A.H.W. Aten, B. Koch, and I. Kommador. *J. Amer. Chem. Soc.*, 1955 77, 5498
77. J.H.T. Ledrut, *Radiochem. Acta.*, 1970, 14, 55
78. H. Elias and C.L. Ndiokewre, *Radiochem Acta*, 1970, 14, 160
79. N. Colebourne, J.F.J. Todd and R. Wolfgang, I.A.E.A. Vienna, 1965 Vol. I, p. 149
80. R.L. Williams and F.S. Rowland, *J. Phys. Chem.*, 1972, 76, 3509
81. C.M. Wai and F.S. Rowland, *J. Amer. Chem. Soc.*, 1968, 90, 3638
82. J.M. Miller and R.W. Dodson, *J. Chem. Phys.*, 1950, 18, 865
83. S.S. Kontis and D.S. Urch, *Radiochem. Acta*, 1971, 15, 21
84. J.B. Evans, J.E. Quinlan, M.C. Sauer and J.E. Willard, *J. Phys Chem.*, 1958, 62, 1351
85. J.A. Merrigan, J.B. Nicholas, and E.P. Rack, *Radiochem. Acta*, 1966, 6, 94
86. T. Shiokawa, T. Sato, and K. Kondo, *Bull. Chem. Soc., Japan*, 1971, 44, 1746
87. A.J.R. de Fonseca, D. Shaw and P.F.D. Shaw, *Radiochem. Acta*, 1972 17, 81.
88. K.E. Collins, G.D. Robinson, and C.H. Collins, *J. Phys. Chem.*, 1972, 76, 3331
89. J.C.W. Chien, and J.E. Willard, *J. Amer. Chem. Soc.*, 1957, 79, 4872
90. M. Milman and P.D.F. Shaw, *J. Chem. Soc.*, 1957, 1310
91. M.D. Mia and P.F.D. Shaw, *Radiochem. Acta*, 1966, 6, 172
- 93 92. M. Milman, *Radiochem. Acta*, 1964, 2, 180
93. A Halpern, *Radiochem. Acta*, 1971, 15, 83

94. G. Gavoret and N. Wanoff, *J. Chem. Phys.*, 1953, 50, 183, 434, 524
95. M.I. Stamouli and N.S. Katsanos, *Radiochem. Acta*, 1968, 9, 13
96. K. Berei and G. Stocklin, *Radiochem. Acta*, 1971, 15, 30
97. G. Levey and J.E. Willard, *J. Chem. Phys.*, 1956, 25, 904
98. E.P. Rack and A.A. Gordous, *J. Chem. Phys.*, 1961, 34, 1855
99. A.F. Reid, *Phys. Rev.*, 1964, 69, 530
100. G. Lagards, J. Ch. Abbe, and J.M. Paulus, *Radiochem. Acta*, 1972, 17, 102
101. G. Levey & J.E. Willard. *J. Am. Chem. Soc.* 74.6161 (1953)
102. Szilard and T.A. Chalmers, *Nature*, 139, 462 (1934)
103. W.F. Libby, *J. Am Chem. Soc.*, 62, 1930 (1940)
104. Franck, J. Rabinowitch, E. Some remarks about Free Radicals and the photochemistry of solutions. *Trans-Far. Soc.*, 30, 120, (1934)

