

THE DEFINITION, PRODUCTION AND VALIDATION OF THE DIRECT VISION STANDARD (DVS) FOR HGVS

Final Report for TfL review

Prepared on behalf of Transport for London

Version 1.1

Prepared by: Dr Steve Summerskill

Dr Russell Marshall

Dr Abby Patterson

Anthony Eland

Dr James Lenard

Loughborough Design School, Loughborough University

1 CONTENTS

2	Executive Summary.....	3
3	Acknowledgments.....	4
4	Introduction	4
5	Background	5
5.1	Summary of the Lds team’s previous experience in understanding direct vision from HGVs	5
5.2	Summary of the ‘Definition of Direct Vision Standards for Heavy Goods Vehilces’ project	7
6	Project aims and objectives	9
7	Stakeholder consultation	10
8	Accident Data	11
8.1	severity of accidents between HGVs and VRUs	12
8.2	Causation data	12
8.3	First point of contact and vehicle manoeuver being performed prior to the accident for accidents where blind spot was reported as the causation factor.....	14
8.4	age of the VRU.....	16
8.5	Summary for the accident data analysis	17
9	Development of the Direct Vision Standard (DVS)	18
9.1	Virtual CAD Based Assessment Methoology	18
9.1.1	The Projection of Direct Field of View	18
9.1.2	Volumetric Assessment of Field Of view.....	22
9.1.3	Quantifying Volumetric Results Against Real World Performance	23
9.2	Vehicle Sample	24
9.2.1	Vehicle Classification N3 vs N3G.....	25
9.2.2	Cab Mounting Height	26
9.2.3	3D Vehicle Data.....	27
9.3	Vehicle Set Up.....	29
9.3.1	Eye Point Definition	29
9.4	The Definition of the Assessment Volume	36
9.4.1	The Vertical Specification of the Assessment Volume.....	37
9.4.2	The Horizontal Specification of the Assessment Volume	37
9.5	Results of the Volumetric Projections	38
9.5.1	Volumetric Results For All Vehicles.....	38
9.5.2	Correlation of Assessment zone Volumes Against VRU Distance	39
9.6	The definition of the star ratings	40
9.6.1	Star Ratings: Zero to Five Star	41
9.6.2	Impact of the Lower Door Window / REAR WINDOW on the DVS Rating	45
10	Validation exercise	45
11	Discussion.....	46
12	Appendices.....	51
A.	candidate assessment volumes	52
	The Vertical Specification of the Assessment Volume	52
	The Horizontal Specification of the Assessment Volume	53

B.	Results of The Volumetric Assessments Explored	56
	Volumetric Results For All Vehicles Using Candidate 1 (Untrimmed) Assessment Zone Volume	56
	Quantifying Volumetric Results Against Real World Performance.....	57
	Correlation Results of Candidate 1 (Untrimmed) Assessment zone Volumes Against VRU Distance	59
	Volumetric Results For All Vehicles Using Candidate 2 (Trimmed) Assessment zone Volumes.....	60
	Correlation Results of Candidate 2 (Trimmed) Assessment Zone Volumes Against VRU Distance.....	61
	Exploring Weighting of the Assessment Zones.....	62
	Exploring Ambinocular Projections	64
C.	Development of the Star Rating Scheme.....	65
	The detailed approach used to find the DVS rating of each vehicle and define the star rating boundaries considering options 1-4	66
	Results for Options 1.	68
	Results for Option 2.....	69
	Results for Option 3.....	70
	Results for Option 4.....	71
	Final Selected DVS Option Subject to Consultation.....	71
D.	DVS protocol	72

2 EXECUTIVE SUMMARY

This report presents research performed by Loughborough Design School (LDS) on behalf of Transport for London. The research has been conducted against a background of over representation of heavy goods vehicles (HGVs) being involved in road traffic accidents with vulnerable road users (VRUs) where 'failed to look properly' and 'vehicle blind-spot' are often reported as the main casual factors in the accident data. Previous work by LDS on driver's vision from HGVs has identified the need to reduce reliance on indirect vision via mirrors through the specification of a direct vision standard (DVS) for HGVs. Recent work commissioned by TfL and performed by the Transport Research Laboratory (TRL) resulted in a draft DVS. This draft DVS has been evaluated and reworked by the LDS team to produce a viable and robust method to quantify direct vision performance of an HGV together with a means to rate that vision performance against a star rating standard. Throughout this process significant stakeholder consultation has been used to support the development of the DVS.

A total of 27 vehicles representing the majority of the current Euro 6 N3 HGV fleet have been modelled in CAD. Where data were available these have been mounted at the highest, lowest and most sold heights to produce a sample of 54 test vehicles. A methodology has been developed that utilises volumetric projection of the field of view of the driver via the windows in the cab. This projection is then intersected with an assessment volume. The result is a volumetric representation of the space around a HGV cab that the driver can see to the front, driver and passenger sides. The volume of this space can be calculated to provide a rating of direct vision performance. An iterative design process was followed that explored different specifications of the assessment zone around the cab, factoring in the collision data with VRUs and the use of weightings to prioritise what needs to be seen. Two weighting schemes were evaluated one prioritising the volumes vertically, recognising the importance of being able to see closer to the ground, and a second prioritising the volumes directionally to address the prevalence of accidents being greater to the front and passenger side when compared to the driver's side. The final specification of the volumetric assessment consists of a single, unweighted zone around the cab, informed by the current coverage of mirrors specified in UNECE regulation 46. This was done to foster direct vision that aims to remove the reliance on mirrors and thus should focus on providing direct vision of the areas currently covered by mirrors. The vehicle sample was then evaluated for its performance using this assessment, providing a volumetric score for each vehicle. These volumetric scores were then quantified by correlating them with a VRU simulation. Thirteen 5th %ile Italian female VRUs were placed around the vehicle and moved laterally to a point at which their head and shoulders could be seen. This served to provide context for the volumetric results such that a particular volume could be equated to an average distance at which the small adult could be seen. Furthermore, the VRU simulations provided a means to translate the volumetric performance into star ratings.

Four star rating specifications were produced following an absolute (based on risk/safety) and a relative (based on the performance of the current fleet) approach. For both absolute and relative two iterations were proposed: 1. the VRU simulation distances were used to establish a threshold value, 2. the median volumetric result was used to establish a threshold value. The final option taken forwards used the VRU simulation distances for a 5th %ile Italian female to define the 1 star boundary. Vehicles able to provide direct vision of the VRUs at an average of <2m to the front, <4.5m to the passenger side and <0.6m to the driver's side achieved a star rating 1 star or above. All others achieved a rating of zero star. Star ratings from 1 to 5 star were sub divided equally.

The final result consists of three main outcomes:

1. A robust, repeatable and validated method for the volumetric analysis of direct vision performance using a CAD based process
2. A process to map a volumetric score for a given vehicle onto the 5 star rating scale to produce a DVS rating for any vehicle.
3. Star ratings for the majority of the Euro 6 N3/N3G HGV fleet showing that of the 41 configurations analysed, two vehicles are rated 5 star, no vehicles are rated 4 star, five vehicles are able to achieve 3 star, three vehicles are able to achieve 2 star, and six vehicles are able to achieve 1 star, the remainder 25 vehicles were rated as zero star.

3 ACKNOWLEDGMENTS

The project described in this report would not have been possible without the considerable support provided by vehicle manufacturers. Each manufacturer has allowed access to their vehicles to allow data to be captured and provided additional information that relates to the vehicle specifications. We would like to thank the following manufacturers and their representatives for their support, DAF, Dennis, Isuzu, IVECO, MAN, Mercedes, Renault, Scania and Volvo.

4 INTRODUCTION

The following report details the production of a system that can be used to rate the performance of Heavy Goods Vehicles in terms of their ability to allow drivers to see vulnerable road users (VRUs) such as cyclists and pedestrians in close proximity to the cab. This method is known as the Direct Vision Standard. In addition to this, the Direct Vision Standard has been applied to the assessment of 54 vehicle makes and models, and the results of these have been analysed to define a 'star rating system'. The rating system uses 6 star ratings from 0 to 5 where 0 designates a poor direct vision performance and 5 designates an excellent direct vision performance. In this way, the performance of a particular vehicle can be communicated in a method that is simple to understand for operators and other stakeholders such as members of the general public.

This project has been funded by Transport for London with the aim of improving safety on the streets of London by limiting access to the city for vehicles with the lowest DVS score, unless additional safety technology is fitted to the worst performing vehicles. In addition, the aim is to foster the use of vehicles which have improved direct vision, and to encourage HGV design teams to show further consideration of direct vision in the vehicle design process.

The case for direct vision has been made by TfL through a series of research projects which it has funded to explore the reasons for the disproportionate number of accidents which occur between VRUs and HGVs. These include, most notably, previous work by the LDS team which explored the size and location of blind spots for a range of existing trucks¹, leading to the recommendation of a direct vision standard for trucks, and a project by ARUP² and Leeds University, which demonstrated that direct vision is more effective than the use of mirrors in allowing HGV driver's to identify the presence of VRUs around a truck cab.

¹ SUMMERSKILL, S. ...et al., 2015. Understanding direct and indirect driver vision in heavy goods vehicles: Final report prepared on behalf of Transport for London. Loughborough: Loughborough University, pp. 1-432.

² ARUP (2016). Exploring the Road Safety Benefits of Direct vs Indirect Vision in HGV Cabs. <http://content.tfl.gov.uk/road-safety-benefits-of-direct-vs-indirect-vision-in-hgv-cabs-technical.pdf>

Over the past 3 years, HGVs were involved in 20% of pedestrian fatalities and over 70% of cyclist fatalities, despite HGVs only making up 4% of road miles in London.

The following report describes the process that has been undertaken to design, test and apply the Direct Vision Standard.

5 BACKGROUND

The following section describes a series of research projects which led to the requirement for a Direct vision standard (DVS) for trucks.

5.1 SUMMARY OF THE LDS TEAM'S PREVIOUS EXPERIENCE IN UNDERSTANDING DIRECT VISION FROM HGVs

The project to define and test the DVS is part of a series of vehicle design and assessment projects that have been performed by the LDS team over a period of 15 years including projects with Shanghai Automotive, Jaguar Land Rover, Honda, The Department for Transport (DfT), Nissan Technical Development Centre Europe, Transport and Environment (T&E, 2017) and Transport for London. As an example of the kind of work that is performed by the team, the project with Nissan, funded by Innovate UK and completed in 2015 involved the design and production of a prototype electric vehicle that allows a novel, more space efficient driving posture to be adopted. This work and other projects performed by the LDS team involve the use of the only UK based Digital Human Modelling system, SAMMIE (System for Aiding Man Machine Interaction Evaluation), which has been developed by the LDS team at Loughborough University since 1980. The use of digital human modelling allows vehicles to be simulated along with the interactions between drivers, vehicles and the wider environment.

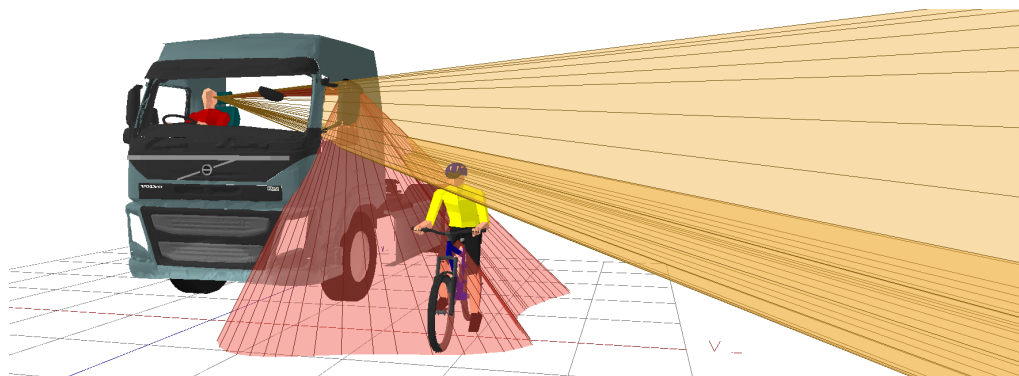

Figure 1. The projection of the Class V (look down) mirror (the red volume) and the space visible through the passenger window (the orange volume)

The LDS team first used SAMMIE to model HGV driver's vision in 2010, in a project for the DfT which resulted in the identification of a key HGV blind spot. This led to the LDS team supporting the DfT by presenting the research to the 100th meeting of the United Nations Economic Commission for Europe General Safety Committee which led to the revision of UNECE regulation 46, improving the coverage of the Class V HGV mirror. This change came onto force in July of 2015, with all new trucks in Europe being required to be fitted with an improved Class V mirror. The DfT project report produced by the LDS team in 2011 discussed the potential difficulty that HGV drivers face in the use of six mirrors and upwards of three windows in gaining situational awareness of VRU locations around the cab and advocated the need for improved direct vision in

HGVs. The CLOCS 'Modelling of HGV Blind Spots' project followed on from the DfT research, using a further developed version of the SAMMIE CAD DHM system which allows the volume of space that is visible to the vehicle driver through windows and mirrors to be visually represented and numerically quantified. See Figure 1.



Figure 2. Images of the vehicle makes and models that were produced during the project

This technique was been used in conjunction with 19 vehicle models (see Figure 2) that have been produced by the LDS team which represent the most sold configurations of HGVs in the UK along with cabs with 'high vision' designs based upon low entry cabs. The combination of the unique visualisation features of SAMMIE and the 19 vehicle models, which have been specifically produced to benefit from these features, has resulted in the analysis of the areas around a vehicle cab which can and cannot be seen by a driver through the use of windows (direct vision) and mirrors (indirect vision). These data and visualisations allow vehicle operators to identify vehicles which have improved direct vision compared to the rest of the vehicle sample and allow vehicle manufacturers to identify how they perform in comparison to competitors. The further analysis of the results identified the key features of vehicle designs which contribute to the size of areas around the vehicle which cannot be seen by the driver (blind spots). The predominant factor was shown to be the mounting height of the vehicle cab above the ground which is affected by the vehicle specification. For example, an N3G cab will generally have a higher maximum height compared to the N3 variant. However, it was also shown that the worst performing vehicle was a category N3 design, illustrating that N3G configurations are not necessarily the worst performing on the road when cabs are assessed at their most sold height. Of the 10 worst performing vehicles 5 were N3 and 5 were N3G. See Figure 3.

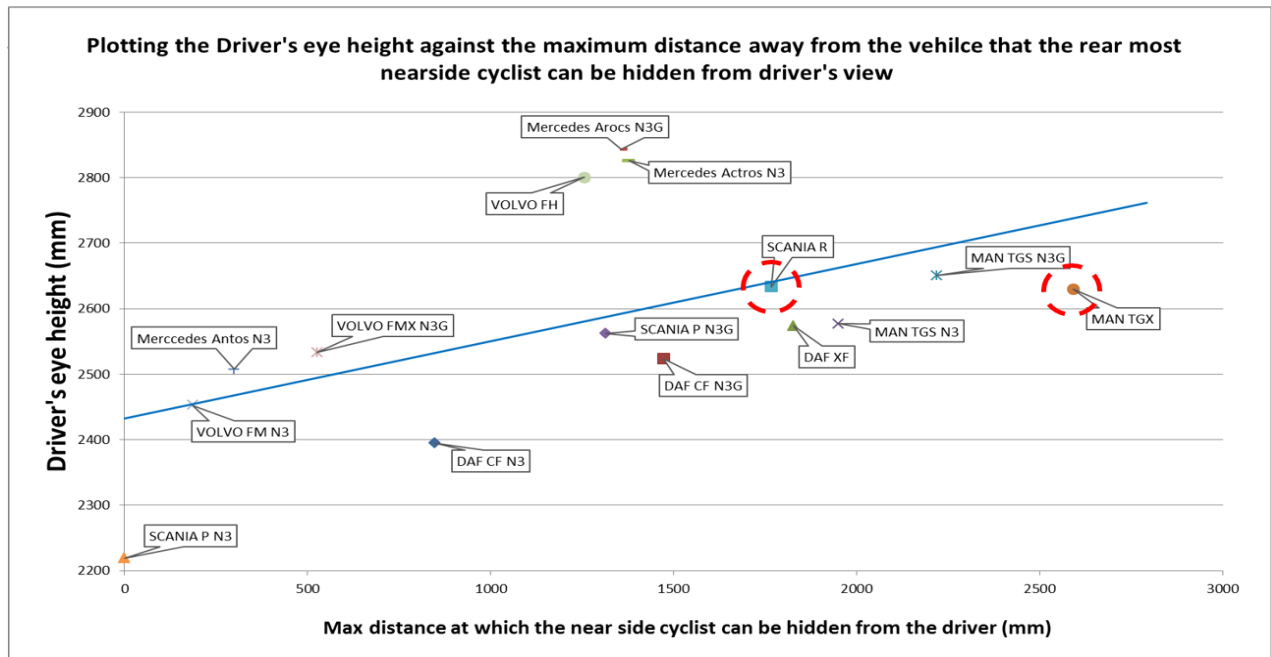

Figure 3. The comparison between the driver’s eye height and the distance away at which a cyclist adjacent to the passenger door can be hidden from the direct vision of the driver

The variability in the design of vehicle cabs with regard to these factors illustrated the need for a direct vision standard with the aim of providing a mechanism for vehicle designers to optimise their designs. This led to the current project to develop the DVS.

5.2 SUMMARY OF THE ‘DEFINITION OF DIRECT VISION STANDARDS FOR HEAVY GOODS VEHICLES’ PROJECT

The recommendation for a Direct Vision Standard by the LDS team led to TfL commissioning the Transport Research Laboratory (TRL) to define a Direct Vision Standard protocol in 2015. This draft version³ of the Direct Vision Standard established (TRL Draft DVS) a base principle of defining a volume of space around the vehicle, with the proportion of that volume that is *not* visible to the driver being the performance metric. Figure 4 shows the definition of the TRL ‘assessment volume’ placed around the truck (top left, right and bottom right images) and the result of the subtraction of the volume that can be seen by the driver (bottom left). In addition, TfL prescribed that the results of the DVS would be demonstrated through the mechanism of a five star rating system. At the start of the project the definition of the star rating system was as per the list below;

- Zero star – Vehicles with this rating would be banned from London in the year 2020
- 1 star - Vehicles with this rating would be banned from London in the year 2024
- 2 star - Vehicles with this rating would be banned from London in the year 2024
- 3 star - Vehicles would be acceptable for use in London
- 4 star - Vehicles would be acceptable for use in London
- 5 star - Vehicles would demonstrate best in class direct vision performance

³ Robinson et al (2015). Definition of Direct Vision Standards for Heavy Goods Vehicles (HGVs) Technical Report

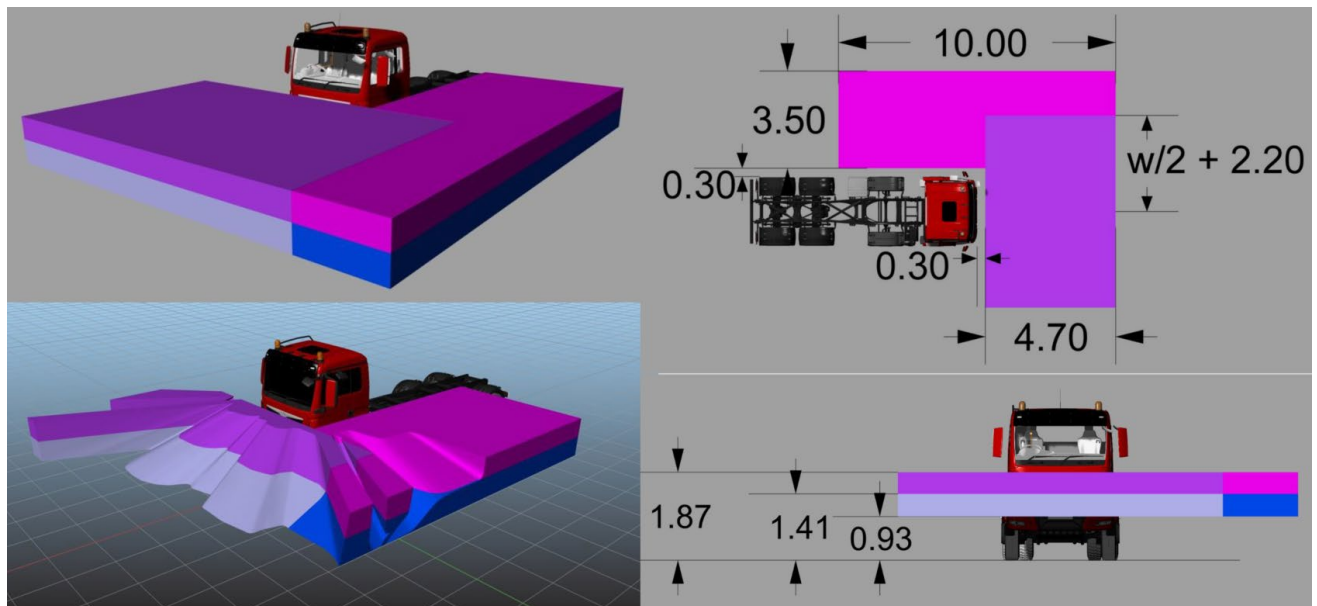

Figure 4. The TRL draft version of the Direct vision standard

The LDS reviewed the outcomes of the ‘Definition of Direct Vision Standards for Heavy Goods Vehicles’ project and identified a number of areas where the definition warranted further refinement. These were;

- The analysis and testing of the DVS had been performed using vehicle CAD data sourced from internet sites that provide visualisation models. Therefore the validity of the CAD data could not be determined. Data was not provided by manufacturers for the TRL work.
- The number of vehicles used in the process included three vehicle designs compared to, for example, the 19 vehicle designs tested in the ‘Modelling of HGV Blind Spots’ LDS project, and so a wider sample was required to ensure the definition of the standard was applicable to the whole fleet. The three vehicles were modified in the TRL study by removing the dash board to provide more conditions for the testing, a design change that would not be possible. The results for the three vehicles were used to define the star rating boundaries, which again required wider consideration for the whole fleet.
- The assessment zone did not cover the offside of the vehicle
- The assessment zone did not cover the full height range down to the floor. Whilst the accident data analysis does not indicate a high proportion of VRU accidents associated with children, wheel chair users, or scooter users, the potential to include these VRUs of all heights in the assessment zone was seen as necessary by the LDS team.
- The assessment zone definition in terms of the dimensions used was based upon a mix of data from different nationalities (North American, for the dimension 0.3m shown in Figure 4, and UK data for the dimensions 1.87m, 1.41m and 0.93m in Figure 4). Given the population of London and UK, data which reflects the anthropometric variability of the European population would be preferred.
- The plan view dimensions of the assessment zone were defined by the average walking speed of pedestrians, and the average cycling speed (which defines the 10m dimension in Figure 4). This was done in an effort to define the starting point of pedestrians and cyclists at the point at which they should be seen by a driver, including the need for a zone which could not currently ever be seen through direct vision by the driver. The specific scenarios used covered a limited number of accidents, and a limited range of actual vulnerable road user capability to move at a certain speed.

Therefore, the LDS team determined that another approach should be taken to the definition of the assessment volume.

- A method which subtracts the volume that is not visible to the driver from the assessment volume produces a contiguous volume (see Figure 4 bottom right image) that cannot be subdivided to determine the performance of the vehicle to the front, left and right separately.

The LDS team were then commissioned by TfL to perform a project which would redefine the DVS from base principles and to validate and test this standard using a sample of vehicles that reflect the UK vehicle parc. In addition, the LDS team would redefine the method by which the star ratings are defined. The following section presents the formal aims and objectives of the project.

6 PROJECT AIMS AND OBJECTIVES

The project requirements were listed in the project ITT document as follows.

- Gain an insight into the profile of existing HGVs (manufacturer and model) that are currently operating on GB roads to establish a representative sample to be modelled against the DVS
- Review, validate and test the DVS assessment protocol to ensure the star rating thresholds are realistically calibrated, redefining the DVS as required
- Ensure the DVS assessment protocol is legally defensible and stands up to the scrutiny of regulators, vehicle manufacturers and representative bodies
- Model a baseline representative sample of HGVs against the DVS star rating that is relevant to their prevalence in the current GB operating market
- Secure the support of the eight principal HGV manufacturers that supply vehicles to the GB market, to encourage application and adoption of the DVS

Upon the winning the contract the LDS team further detailed the project objectives as shown below.

- To perform an analysis of the accident data both nationally and with respect to accidents in London to establish the area of greatest risk around the truck
- This analysis was specified to use the UK STATS 19 accident database with the additional use of 'causation' data which is collected at the scene
- To explore the potential of using the accident data and the areas of greatest risk to 'weight' the volumetric scores for particular areas around the truck cab
- To develop a CAD based methodology from base principles and develop a range of candidate assessment volumes to be tested with a full sample of vehicles
- To define the required sample using vehicle registration data
- To engage with vehicle manufacturers and other stakeholders to explain the DVS process and secure access to CAD data for the vehicles, or access to vehicles for 3D scanning
- To test the candidate rating schemes against the sample and refine the assessment methodology based upon the results that are achieved
- To define a method that quantifies the abstract nature of the assessment volume scoring system using a methodology that reflects the real-world problem
- The use of the combination of all data to define a star rating system

The following sections section describe how each of the objectives have been achieved.

7 STAKEHOLDER CONSULTATION

The project has been supported by the vehicle manufacturers and other stakeholders through a stakeholder consultation process. A range of engagement activities have been performed to ensure that the LDS and Tfl teams were aware of the design processes and constraints involved in vehicle design, aware of the efforts that certain manufacturers already place into the design of vehicles to improve direct vision and aware of range of types of trucks that are produced.

Many of the manufacturers had reviewed the draft TRL DVS prior to the project starting, and so it was important to clarify with manufacturers that this was not the definitive version and inform them of the further work that LDS team would be performing to move the DVS forward. The following in a chronological list of visits and meetings that have been held during the course of the project.

- Dr Steve Summerskill visited the SCANIA development centre in Stockholm, Sweden, in Sept of 2016 and presented the LDS previous work, along with the draft DVS, to the whole development team of engineers and human factors/HMI engineers
- Dr Steve Summerskill (LDS), Hannah White (Tfl) and Ben Plowden (Tfl) and Dr Russell Marshall (LDS) visited the Volvo development team (headed by Avedal Claes) in Gothenburg, Sweden, in December of 2016. Representatives from Renault Trucks were also present. This visit included a review of how the Volvo staff had tried to implement the draft TRL DVS and had identified the issues relating to the difficulty associated with combining ambinoocular projections, and the complexity of the eye point projection used in the DVS.
- The DAF development team (headed by Johan Broeders) visited the LDS team at Loughborough University. Tfl staff Hannah White and Glen Davies were also in attendance. The DAF team raised a number of issues for consideration including the same issues raised by the Volvo/Renault teams, and the issues of how the DVS would deal wind screen wipers.
- Dr Summerskill Visited Phil Rootham (Scania, Milton Keynes) in February of 2017.
- A stake holder event took place at Loughborough University in March of 2017 during which progress regarding the accident data analysis and the definition of candidate DVS schemes was presented to representatives of all manufacturers, The UK Department for Transport, The SMMT, and the FTA.
- Dr Steve Summerskill (LDS) and Hannah White (Tfl) visited the Daimler cab development team (Led by Stefan Huegin) in Stuttgart in March of 2017 in an effort to secure CAD data for the Mercedes vehicles. This was a successful meeting which improved the understanding of the Mercedes range by the LDS team and led to access to CAD data.
- A stakeholder event was held in London in June of 2017 with representatives of all manufacturers, The SMMT, The UK Department for Transport, ARUP and the FTA. During this meeting a draft version of the DVS process and results were presented. This presentation was widely accepted with a positive attitude from manufacturers with some suggestions for improvement in the process including the use of a DVS rating to all sides of the vehicle as discussed in section 8.
- A stakeholder event was held in London in October of 2017 which explored an emerging issues associated with the none standard approach that manufacturers use to standardise the seat position in the cab. This variability led to the redefinition of the DVS eye point.
- A stakeholder event was held in London in December of 2017 which reviewed the proposed eye point definition redesign and reviewed the results of the analysis that was performed.

- A stakeholder event was held in London in February of 2018 which reviewed the proposed inclusion of the passenger side window rear of the B-pillar (PWSRBP) in the analysis at the request of the manufacturers.
- A stakeholder event was held in London in February of 2018 which reviewed the proposed inclusion of the passenger side window rear of the B-pillar (PWSRBP) in the analysis at the request of the manufacturers.
- A stakeholder event was held in London in May of 2018 which reviewed the draft DVS protocol
- A stakeholder event was held in London in August of 2018 which reviewed the draft DVS protocol

Further engagement has been performed with the European Union through the mechanism of the UNECE VRU PROXI group (an informal committee that supports the development of standard at the UNECE). The LDS and TfL teams were asked to join this committee in an effort to support the potential adoption of the TfL DVS in Europe. The TfL and LDS teams have attended three meetings at the time of writing, which has led to further in the development of the DVS.

In addition to these face to meetings there have been regular phone calls and emails to manufacturer representatives and members of design teams. This included a valuable validation exercise performed with one manufacturer in September of 2017 as discussed in section 10.

8 ACCIDENT DATA

The accident data analysis started with the sourcing of the STATS 19 data base results from the UK Department for Transport (DfT). This analysis was performed for all accidents between 2010 and 2015 due to the quality of the data that is available for that date range compared to earlier available data. Nationally this involves 2443 accidents. Each accident is categorised and recorded by a police officer using the STATS 19 accident recording form which is used when someone has been injured or killed on the highway. There are numerous accident categories including data on accident causation which had to be specially requested by the LDS accident data analyst. The accident database that we have in the UK is widely regarded as being the most detailed in Europe. The data contains a wide range of fields which can be used to explore specific issues. For this project we have used the following fields;

- Accident causation data (e.g. Blind spot, did not look properly etc.) extra layer of data that must be requested from DfT
- The severity of the accident (Fatal, serious or slight)
- The vehicles and other people involved (e.g. HGVs above 7.5 tonnes, pedestrian, cyclist)
- The Police force which has captured the data which allows us to compare the data in London and nationally
- First point of contact between the vulnerable road user and the vehicle
- Category of vehicle (e.g. rigid or articulated)
- Vehicle manoeuvre being performed when the accident occurred (e.g. turning left, going straight on)
- Junction type
- Vehicle make and year of first registration
- Speed limit on the road where the accident occurred
- Lighting and weather conditions
- Age of the casualty

The analysis of the UK accident database (STATS 19) for accidents between Vulnerable road users and HGVs above 7.5 tonnes has been performed. The processing of the accident data allows the analysis of specific scenarios, such as the number of accidents that occur between HGVs and cyclists or pedestrians, the severity of those accidents, the first point of contact between the vehicle and the VRU, and the causation that has been assigned by the attending police officer. The following sections describe the manner in which the data has been interrogated and the results which were derived.

8.1 SEVERITY OF ACCIDENTS BETWEEN HGVs AND VRUS

The analysis of the results initially highlighted the severity of the accidents that occurred between VRUs and HGVs through a comparison to the whole STATS 19 database for all accident types.

For accidents between HGVs and cyclists and HGVs and pedestrians the following figures were derived for the number and percentage of accidents in the sample that were rated as fatal, serious or slight.

- Cyclists: 93 fatal (8%) – 336 serious (27%) – 773 – slight (64)%
- Pedestrians: 226 fatal (18%) – 362 serious (29%) – 653 – slight (53)%

Therefore 35% of accidents between HGVs and cyclists and 47% of accidents between HGVs and pedestrians involve some being killed or seriously injured (KSI). This was compared to the whole STATS 19 database for all accident types which showed the following results.

- 1732 fatal (1%) – 22137 Serious (12%) – 162340 slight (87%)

Therefore 13% of all accidents recorded in STATS 19 involve someone being killed or seriously injured. Clearly the consequences of an accident between an HGV and a VRU are more severe.

8.2 CAUSATION DATA

The causation data that has been requested from the DfT is shown below. Table 1 shows the causation data for all accidents between HGVs and pedestrians. This shows that the predominant causation factor linked to these accidents were “Failed to look properly” and “ Vehicle blind spot”. Table 2 shows the causation data for all accidents between HGVs and cyclists. This shows that the predominant causation factor linked to these accidents was “Failed to look properly” with a high occurrence of “ Vehicle blind spot”.

Whilst it is possible that some of the cases labelled as “Failed to look properly” involved a blind spot without the knowledge of the Police officer, the LDS team have not made such assumptions.

Table 3 shows the causation data for accidents between HGVs and cyclists for London in the stated period. Here we see that the main causation factor was “ Vehicle blind spot” with a high occurrence of “Failed to look properly”.

Causation data for the top 95% of accidents with pedestrians and HGVs above 7.5 tonnes (2010 – 2015)	
<i>No. of accidents</i>	<i>Causation category</i>
284	Failed to look properly
125	Vehicle blind spot
105	Poor turn or manoeuvre
101	Passing too close to cyclist
80	Careless
50	Failed to judge other person's path or speed
39	Other – Please specify below
31	Overloaded or poorly loaded vehicle or trailer
26	Stationary or parked vehicle(s)
23	Road layout (eg. bend)
12	Temporary road layout (eg. contraflow)
12	Vehicle travelling along pavement
11	Disobeyed pedestrian crossing facility
11	Junction restart (moving off at junction)
10	Travelling too fast for conditions
9	Aggressive driving
8	Illegal turn or direction of travel
8	Swerved
7	Distraction outside vehicle
6	Road layout (eg. bend)
6	Rain
6	Sudden braking
6	Dazzling sun
6	Slippery road (due to weather)
5	Loss of control
5	Vehicle door opened or closed negligently
4	Animal or object in carriageway
4	Poor or defective road surface
4	Junction overshoot
4	Exceeding speed limit
4	Driver using mobile phone
4	Distraction in vehicle
3	Vegetation

Table 1. The causation data for accidents between HGVs and Pedestrians

Causation data for the top 95% of accidents with cyclists and HGVs above 7.5 tonnes (2010 – 2015)	
<i>No. of accidents</i>	<i>Causation category</i>
723	Failed to look properly
357	Failed to judge other person's path or speed
321	Passing too close to cyclist horse rider or pedestrian
257	Poor turn or manoeuvre
219	Careless reckless or in a hurry
159	Vehicle blind spot
77	Loss of control
58	Cyclist entering road from pavement
39	Cyclist wearing dark clothing at night
36	Following too close
34	Other – Please specify below
33	Swerved
28	Road layout (eg. Bend hill narrow carriageway)
27	Junction restart (moving off at junction)
26	Vehicle door opened or closed negligently
24	Travelling too fast for conditions
23	Not displaying lights at night or in poor visibility
22	Failed to signal or misleading signal
21	Dazzling sun
19	Disobeyed 'Give Way' or 'Stop' sign or markings
18	Impaired by alcohol
17	Sudden braking
16	Stationary or parked vehicle(s)
16	Slippery road (due to weather)
16	Disobeyed automatic traffic signal
15	Nervous uncertain or panic
15	Aggressive driving
12	Rain sleet snow or fog
11	Vehicle travelling along pavement
10	Junction overshoot
10	Learner or inexperienced driver/rider
10	Poor or defective road surface
10	Fatigue

Table 2. The causation data for accidents between HGVs and Cyclists

London Only data	
47	Vehicle blind spot
21	Failed to look properly
4	Junction restart (moving off at junction)
4	Passing too close to cyclist horse rider or pedestrian
3	Poor turn or manoeuvre
3	Careless reckless or in a hurry
2	Temporary road layout (eg. contraflow)
1	Stationary or parked vehicle(s)
1	Illegal turn or direction of travel

Table 3. The causation data for accidents between HGVs and Cyclists in London

In either the case for the national data or the London data, a key issue that has been highlighted by the causation data is that a lack of ability to see the VRU is a contributory factor in accidents.

8.3 FIRST POINT OF CONTACT AND VEHICLE MANOEUVRE BEING PERFORMED PRIOR TO THE ACCIDENT FOR ACCIDENTS WHERE BLIND SPOT WAS REPORTED AS THE CAUSATION FACTOR

Following on from the analysis of the severity of the accidents, the first point of impact data were interrogated. These data are important as they highlight the location of the VRU in respect to the HGV at the point of impact. In the case of pedestrians, they highlight the locations around the vehicle in which the pedestrian should have been seen by a driver using either direct vision through the windows or indirect vision through the mirrors. For cyclists, the potential variation of the speed of the cyclist make the interpretation of the cyclist location seconds before impact more uncertain. For example, if the first point of impact is the left-hand side of the cab adjacent to the cab there are two example accident scenarios considered. The first is that the cyclist was stationary and next to the vehicle at the point of impact (not seen by the driver in the Class V mirror or windows). The second is that the cyclist was approaching the HGV from the rear at speed, and down the left-hand side of the cab. The first situation can potentially be improved by better direct vision, the second will rely upon the ability of the driver to look in the left-hand Class II and Class IV mirrors at the correct time to see the cyclist.

- For the national data, first point of impact for cyclists = 16% to the front, 74% to passenger side and 11% to the driver's side
- For the national data, first point of impact for pedestrians = 56% to the front, 35% to passenger side and 9% to the driver's side

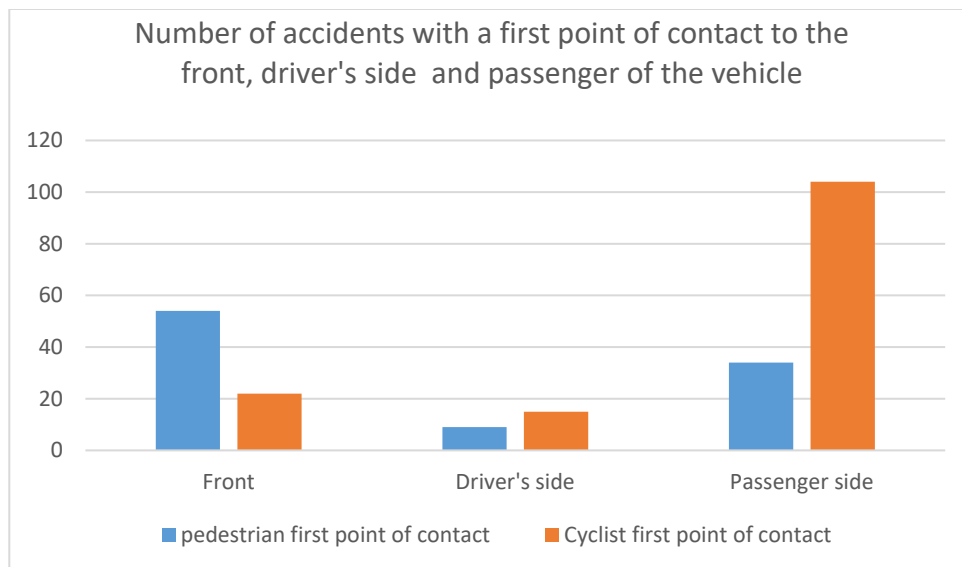

	Pedestrian first point of contact	Cyclist first point of contact	Combined	Percentage
Front	54	22	76	32
Driver's side	9	15	24	10
Passenger side	34	104	138	58
Total	97	141	238	

Figure 5. Number of accidents with a first point of contact to the front, offside and nearside of the vehicle

The cyclist and pedestrian data were combined to produce the percentage of accidents occurring in each of three zones as shown in Figure 6.

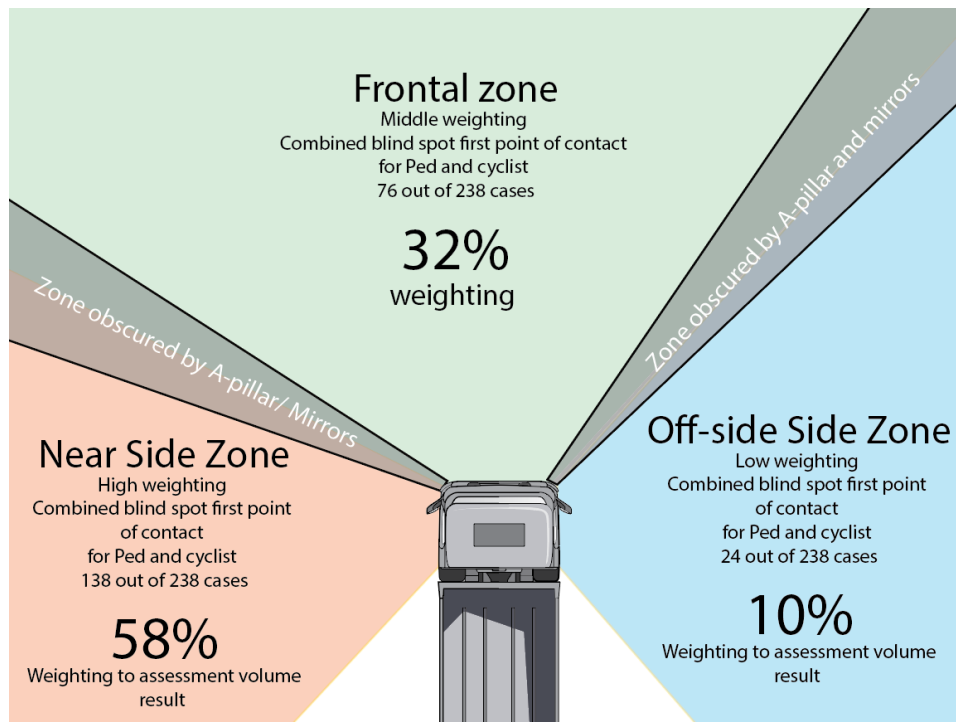

Figure 6. The combined % of accidents which occur to the front, left and right of a right hand drive vehicle in the UK

During the initial stages of the project it was anticipated that these percentages could be used as weighting factor for the volumetric results for trucks. Appendix B shows the exploration of the benefits of these weightings.

The vehicle manoeuvres that are being performing during accidents with vulnerable road users are presented below for the cases where a blind spot was specified for the causation factor for national data.

Vehicle manoeuvre prior to accident: Cyclist		
No of incidents	Manoeuvre	% for each type
71	Turning left	46.71
20	Going ahead other	13.16
19	Moving off	12.5
13	Overtaking moving vehicle - offside	8.55
10	Turning right	6.58
6	Parked	3.95
3	Changing lane to left	1.97
3	Going ahead left-hand bend	1.97
2	Waiting to go - held up	1.32
1	Reversing	0.66
1	Slowing or stopping	0.66
1	U-turn	0.66
1	Overtaking static vehicle - offside	0.66
1	Overtaking - nearside	0.66

Table 4. Vehicle manoeuvre being performed during the accident: Cyclist

Vehicle manoeuvre prior to accident: Pedestrian		
No of incidents	Manoeuvre	% for each type
52	Moving off	41.6
25	Reversing	20
25	Going ahead left-hand bend	20
16	Going	12.8
15	Turning left	12
9	Turning right	7.2
2	Waiting to go - held up	1.6
2	Waiting to turn left	1.6
2	Going ahead left-hand bend	1.6
2	Going ahead other	1.6
1	U-turn	0.8
1	Going ahead right-hand bend	0.8

Table 5. The causation data for accidents between HGVs and Cyclists in London

The data for the manoeuvre that the HGV is making during the accident indicates that for cyclists the situation with the most casualties is associated with the vehicle turning left at junctions. Based upon the first contact data it can be inferred that left turning accidents where the cyclist is on the left-hand side of the vehicle are common accident scenarios.

The data for the manoeuvre that the HGV is making during the accident indicates that for pedestrians the situation with the most casualties is associated with the vehicle moving off from a stand still. Again, this matches with the first contact data which shows that the front of the vehicle is the most common first point of contact.

8.4 AGE OF THE VRU

The final analysis explored the age of the VRUs involved in accidents. The graph in Figure 7 shows a peak in the data for cyclists around the age of 25, as might be expected for the age of cyclists that are willing to commute in the capital. There is also an increase in pedestrian casualties for pedestrians above the age 60. However, there is no reason that pedestrians should have a higher prevalence of over 60's. It can be inferred that people over the age of 60 are disproportionately represented when one considers the most common point of contact and manoeuvre, i.e. to the front, and moving off respectively. Therefore, there is the potential for older people to be unable to move out of the way of truck that is moving off at a pedestrian crossing or junction.

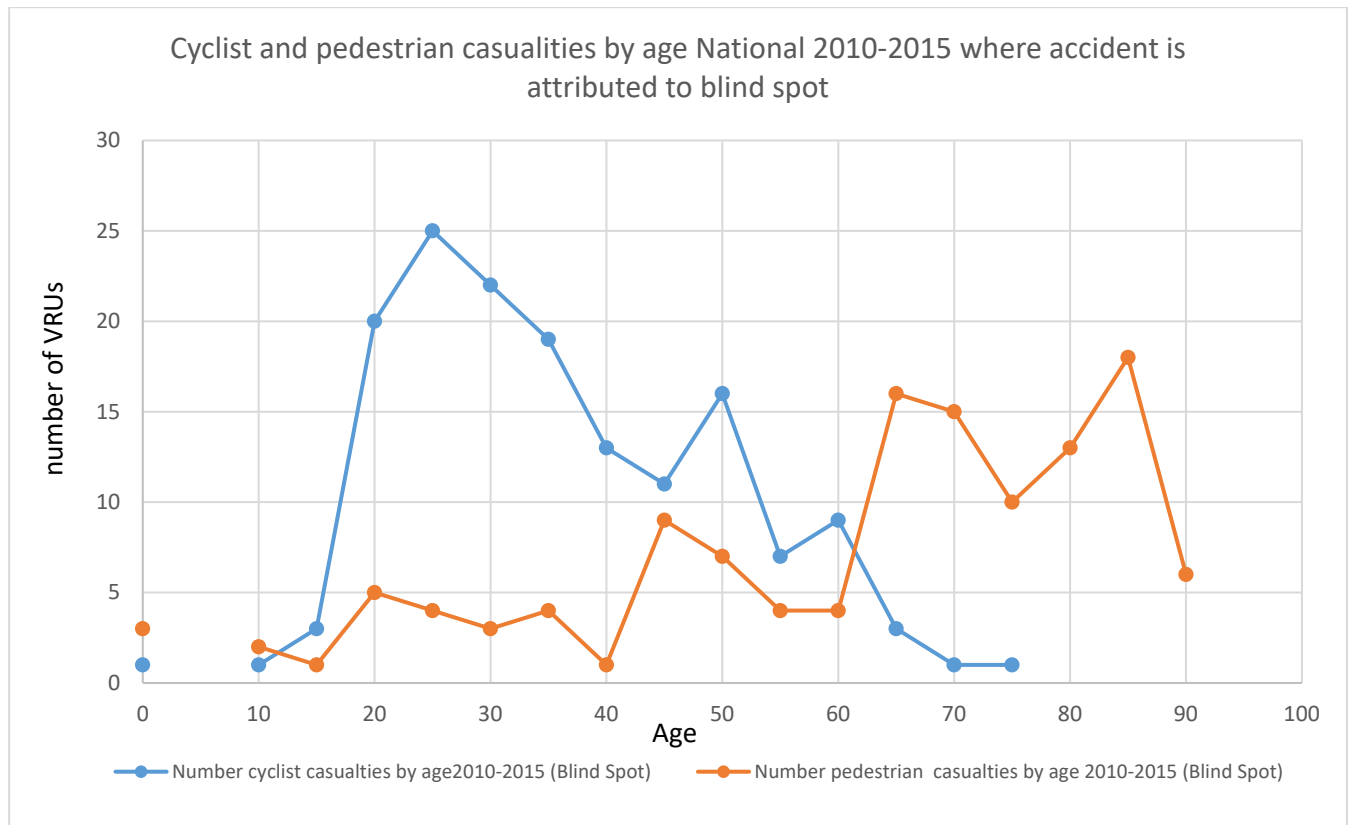

Figure 7. The number of VRU involved in accidents where blind spot was attributed as the contributory factor by age

8.5 SUMMARY FOR THE ACCIDENT DATA ANALYSIS

The accident data analysis has highlighted the following issues;

- The severity of an accident between VRUs and an HGV is higher than the severity of accidents in general with 35% of accidents between HGVs and cyclists and 47% of accidents between HGVs and pedestrians involve someone being killed or seriously injured, compared to 13% for all accidents
- For the national data associated with cyclist and pedestrian accidents the most common causation factors are associated with not seeing the VRU
- The frontal area is the most common first contact point for pedestrians
- The Passenger side area is the most common first contact point for cyclists
- The combination of the cyclist and pedestrian first contact points creates data which can be used to determine the areas of greatest risk around the vehicle, with the nearside having 58% of accidents, the front have 32% of accidents. 10% of accidents have a first contact point on the offside
- These data have the potential to be applied as weightings to the volumetric data if the volumetric data is subdivided to the front, right and left of the cab
- The most common manoeuvre being performed during an accident is moving off for pedestrians and turning left for cyclists
- The age of pedestrian casualties is disproportionately skewed to the older population.
- These summary points have been used in the development of the DVS as described in the following sections.

9 DEVELOPMENT OF THE DIRECT VISION STANDARD (DVS)

As introduced in Section 5.2 the initial method for establishing the DVS exhibited the following characteristics:

- A virtual assessment
- A volumetric assessment of the field of view
- The volume would be limited to key areas around the vehicle

The following sections detail the development of the DVS from these characteristics through to the final proposal through consideration of the following variables.

- The Projection of Direct Field of View
- Volumetric Assessment of Field Of view
- Quantifying Volumetric Results Against Real World Performance

9.1 VIRTUAL CAD BASED ASSESSMENT METHODOLOGY

The Draft TRL DVS protocol developed by TRL⁴ that details the initial DVS approach outlines the use of a CAD based methodology that provides a virtual assessment of direct field of vision performance. Previous work by LDS including blind spot evaluations for the UK Department for Transport⁵ and understanding direct and indirect vision from HGVs for TfL⁶ demonstrated the efficacy of this virtual approach. Building upon that work the DVS would also exploit a virtual assessment using a CAD based method that would allow the direct field of view from a 3D model of any HGV to be evaluated and rated against the standard. It was also deemed to be important to develop a method that would be accessible by the industry. In previous work the DHM tool SAMMIE, a tool developed by the LDS team, was used for the majority of evaluations. However, it was considered important for this project to develop generic methods using industry standard tools that would be applicable by all stakeholders.

9.1.1 THE PROJECTION OF DIRECT FIELD OF VIEW

The evaluation of field of view in a CAD environment consists of a number of key elements. These elements consist of: an eye point, a series of apertures and / or mirrors from which to project the field of view, and a means to extrapolate from the eyepoint, through the apertures (or mirrors) to produce a projection of the visible area or volume of space afforded the driver as shown in Figure 8.

For the DVS the projections would only be assessing direct vision (via windows) and so mirrors would not be projected as part of the field of view, though they would be considered as part of the obscuration to direct vision where they impinge on the field of view from the windows. As already discussed it was important to develop an accessible methodology that could be implemented using equivalent tools in industry standard

⁴ Robinson, T., et al., (2015). Definition of Direct Vision Standards for Heavy Goods Vehicles (HGVs) Technical Report

⁵ Cook, S. E., et al., (2011). The development of improvements to drivers' direct and indirect vision from vehicles. Phase 2. Loughborough University. Report for Department for Transport.

⁶ Summerskill, S., et al., (2015). Understanding direct and indirect driver vision in heavy goods vehicles. Loughborough University. Report for Transport for London.

CAD systems. The process developed below illustrates the method developed for the volumetric projection of direct vision demonstrated in the CAD software Rhino⁷.

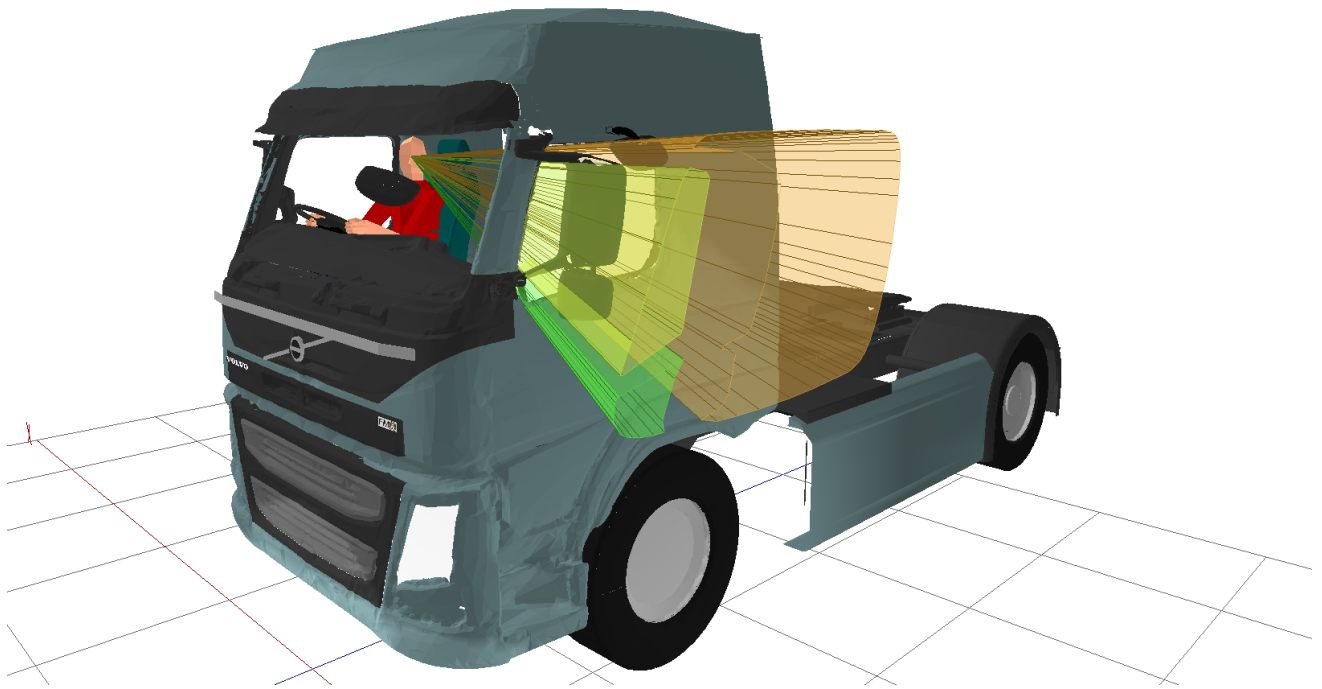

Figure 8. Volumetric projection of the nearside window illustrating the projection of the visible volumes around the obscuration caused by the mirrors.

The process begins with the definition of an eye point. The process for defining an eye point is detailed later in Section 9.3.1. From this eye point an outline must be produced that represents the limits of a given aperture through which the driver would be able to see. Figure 9 shows the view from the eye point through the windscreen. For the projection, the inner path of the visible portion of the windscreen glass needs to be traced taking account of any obscuration from mirrors, steering wheel, windscreen wipers etc. Figure 10, Figure 11, Figure 12 and Figure 13 show how this is performed in the Rhino CAD software. This process uses a tool called MeshOutline to automatically trace the relevant area. The way in which this is performed is not relevant in this instance but it is important that the continuity of the curves is high with sufficient points to capture the complex curvature accurately. In addition, care must be taken to outline all visible areas such as those between the wipers and the frit (fade off) and through the steering wheel. Tiny areas such as those shown in Figure 11 caused by small gaps in the wiper arms can be ignored as their contribution to direct vision is effectively zero.

⁷ Rhinoceros. Robert McNeel & Associates (2017). Available at: <https://www.rhino3d.com/>

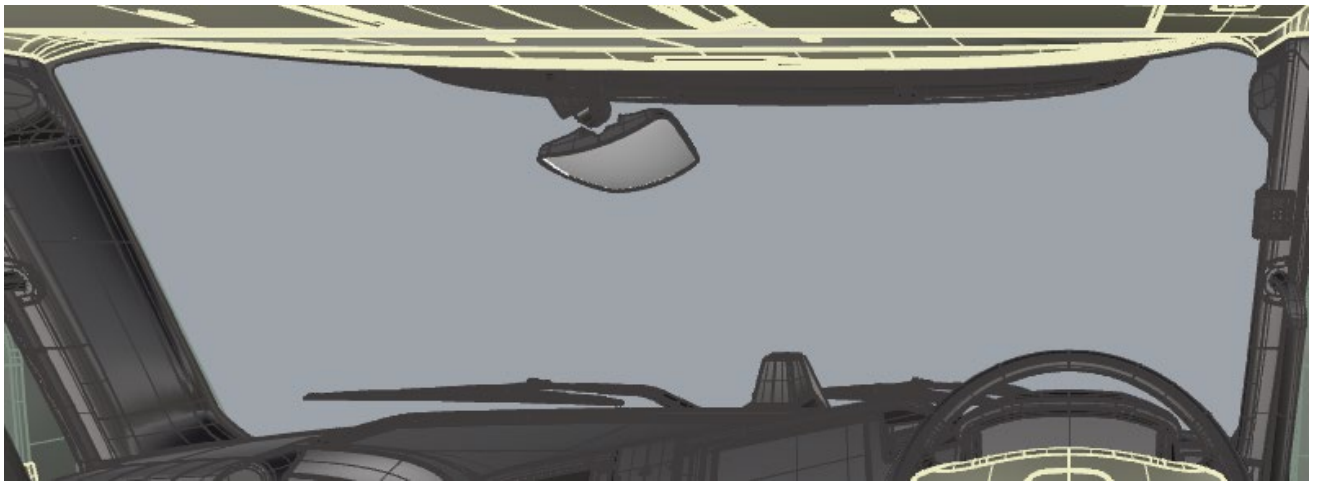

Figure 9. View from the eye point through the front windscreen

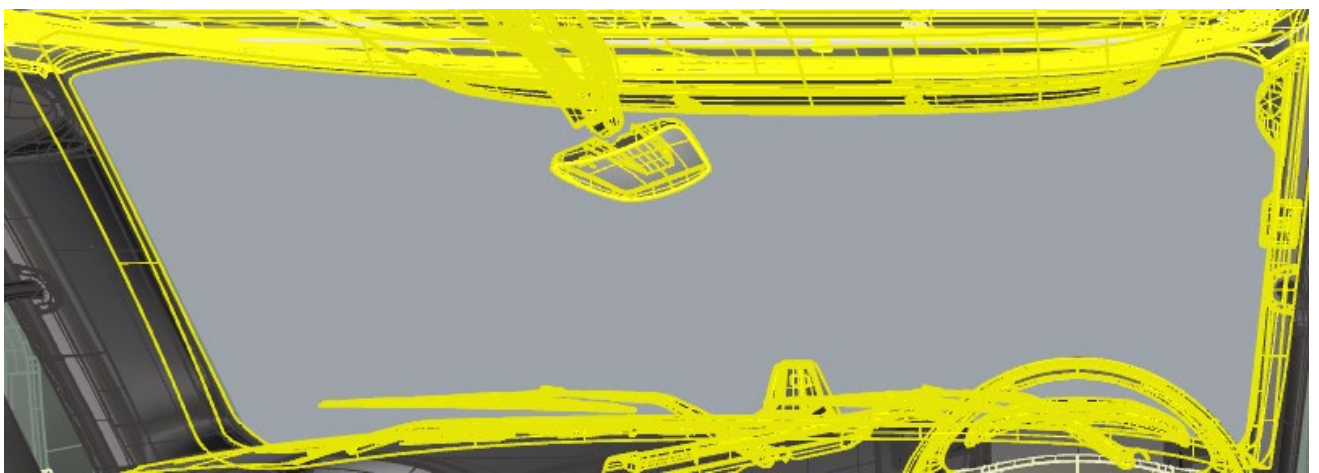

Figure 10. Relevant geometry selected for outlining



Figure 11. Outline of relevant geometry after use of the Rhino MeshOutline tool

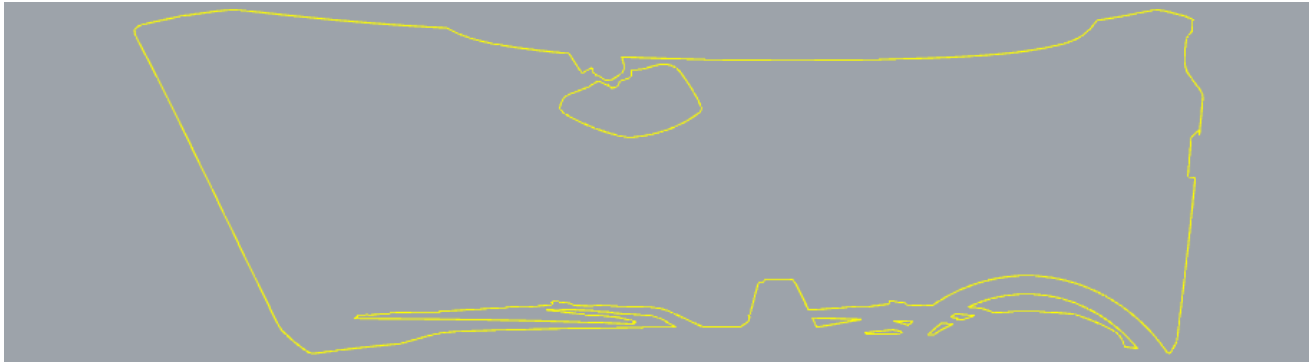

Figure 12. Outlines reduced to the visible areas using the Rhino Curve Boolean tool

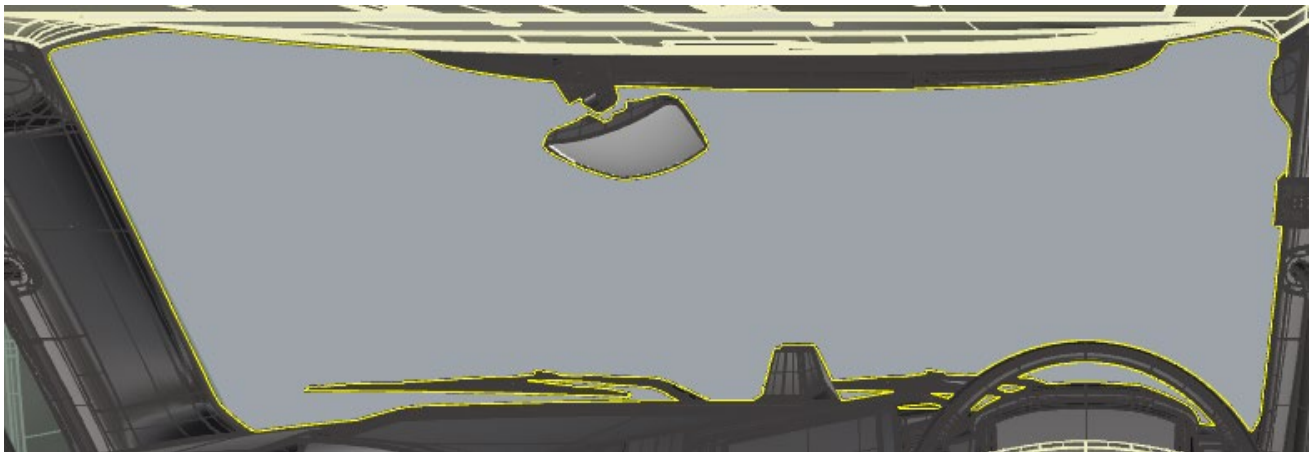

Figure 13. Illustration of the visible outlines mapped onto the CAD geometry

Once the visible area has been defined this is converted into the volumetric projection. In the example tool Rhino, this involves extruding the curves back to the eye point as shown in Figure 14 and Figure 15. Once the basic projection has been produced it can be scaled from the eye point to extend the projection if required.

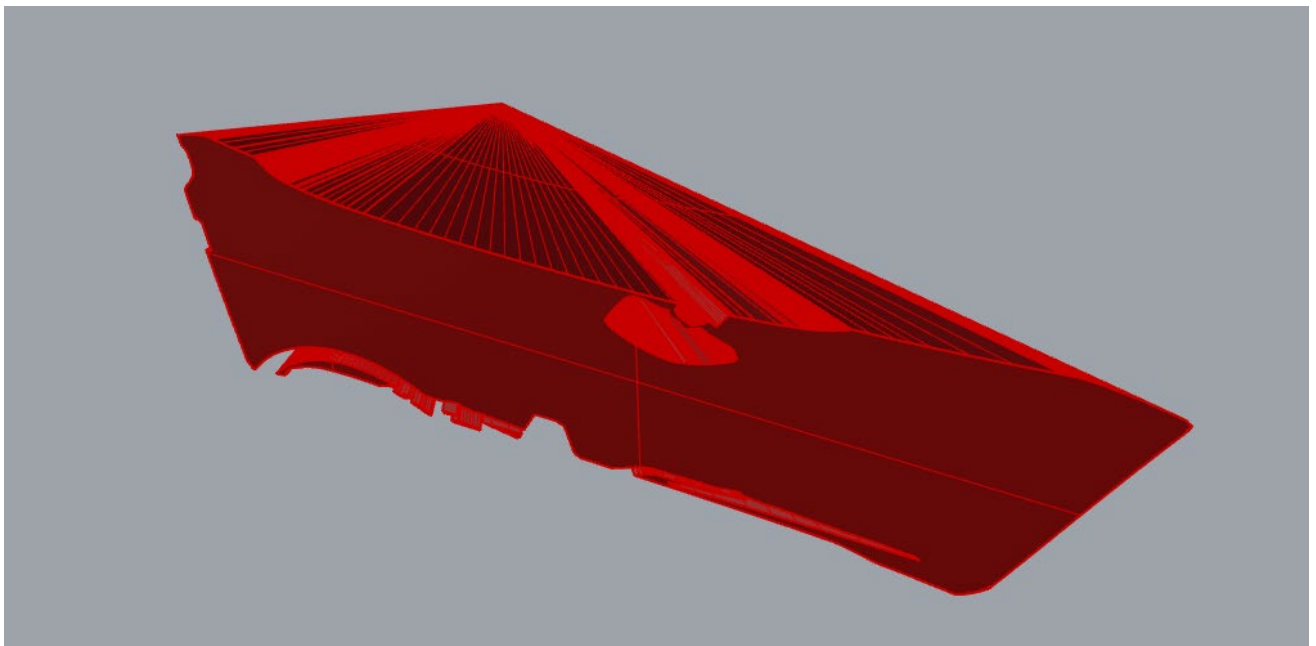

Figure 14. Volumetric projection of the visible outline from the eye point using the Rhino Extrude Planar Curve to Point tool

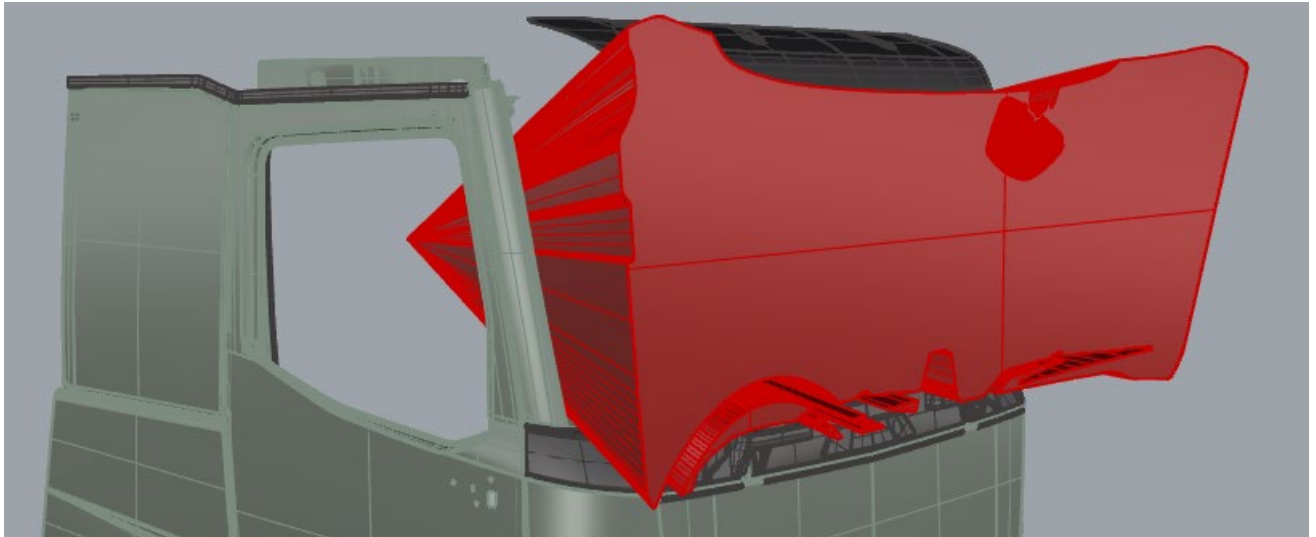

Figure 15. Illustration of the volumetric projection extending from the windscreen area of the cab

The process is then repeated for each window including the driver's side, passenger side and any lower door window that may be present as shown in Figure 16.

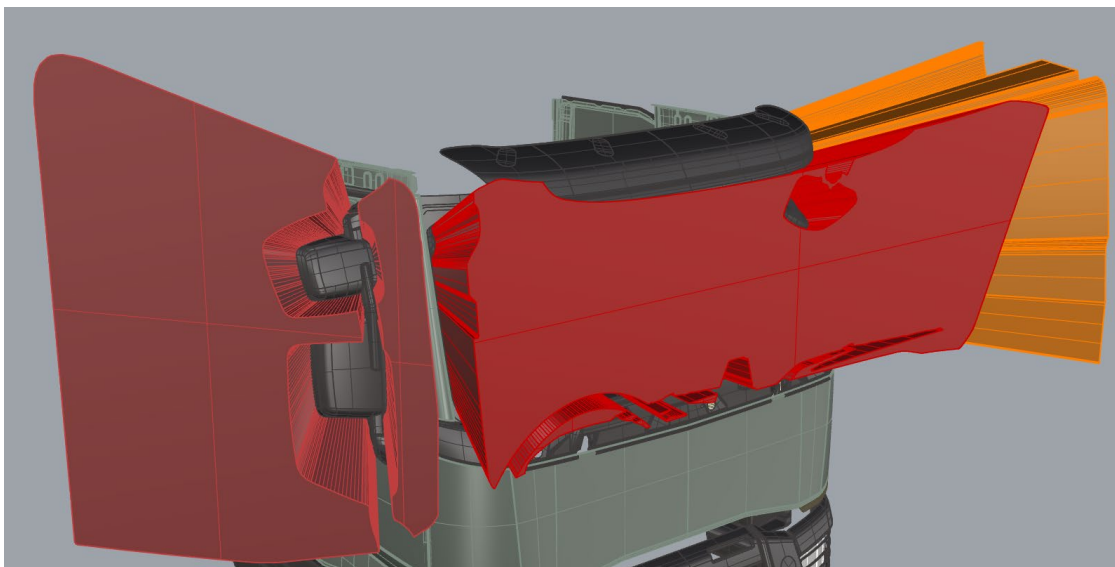

Figure 16. Complete set of projections for the three windows of this vehicle

9.1.2 VOLUMETRIC ASSESSMENT OF FIELD OF VIEW

In order to provide a volumetric evaluation of the field of view from the vehicle the projections as detailed in Section 9.1.1 would need to be intersected with an assessment volume. In contrast to the method proposed in the TRL Draft DVS, the process here would evaluate the visible volume, rather than the volume that cannot be seen. The advantages of this approach are that three discrete volumes are produced that allow weighting to be applied for front, left and right if required. In addition, they produce much more accessible results in which visualisations are much more meaningful if stakeholders are presented with an image of what can be seen rather than a more abstract image of what cannot be seen as shown in Figure 17. The projection and the assessment volume are intersected using a common CAD operation called a Boolean intersection. The resulting geometry can then have its volume calculated to provide a rating. The development of the assessment volumes is detailed in Section 9.4

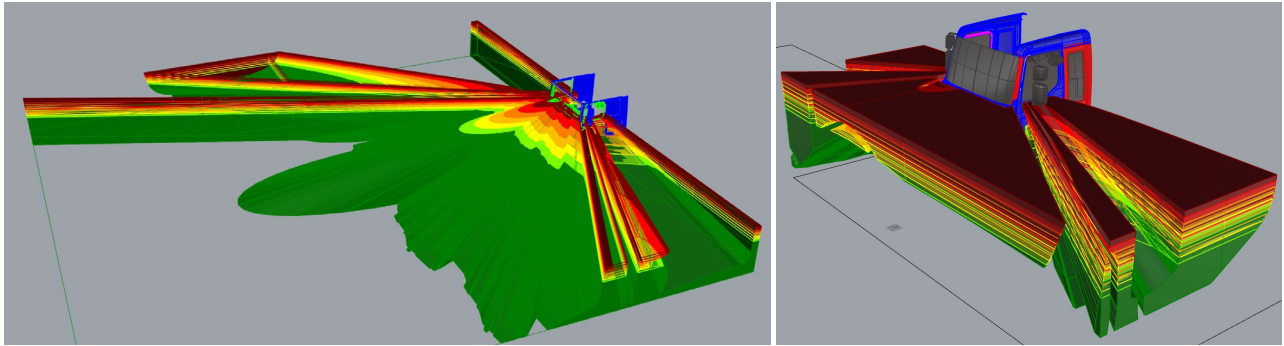

Figure 17. Example of the volumetric assessment process with an assessment showing what cannot be seen on the left and what can be seen on the right

9.1.3 QUANTIFYING VOLUMETRIC RESULTS AGAINST REAL WORLD PERFORMANCE

The volumetric evaluation provides a high resolution assessment of the field of view afforded to the driver. However, the volumetric score is rather abstract in nature a difficult to relate to real world performance. It was deemed appropriate to quantify the volumetric results against real world performance using VRU simulations following a methodology established in previous work by the LDS team. The quantification consists of pedestrian VRU simulations (human models of a given stature) placed around the vehicle and moved laterally to a point at which their head and shoulders is visible to the driver as shown in Figure 18. A number of candidate VRU assessments were explored in order to define the chosen approach, these are detailed in Appendix B.

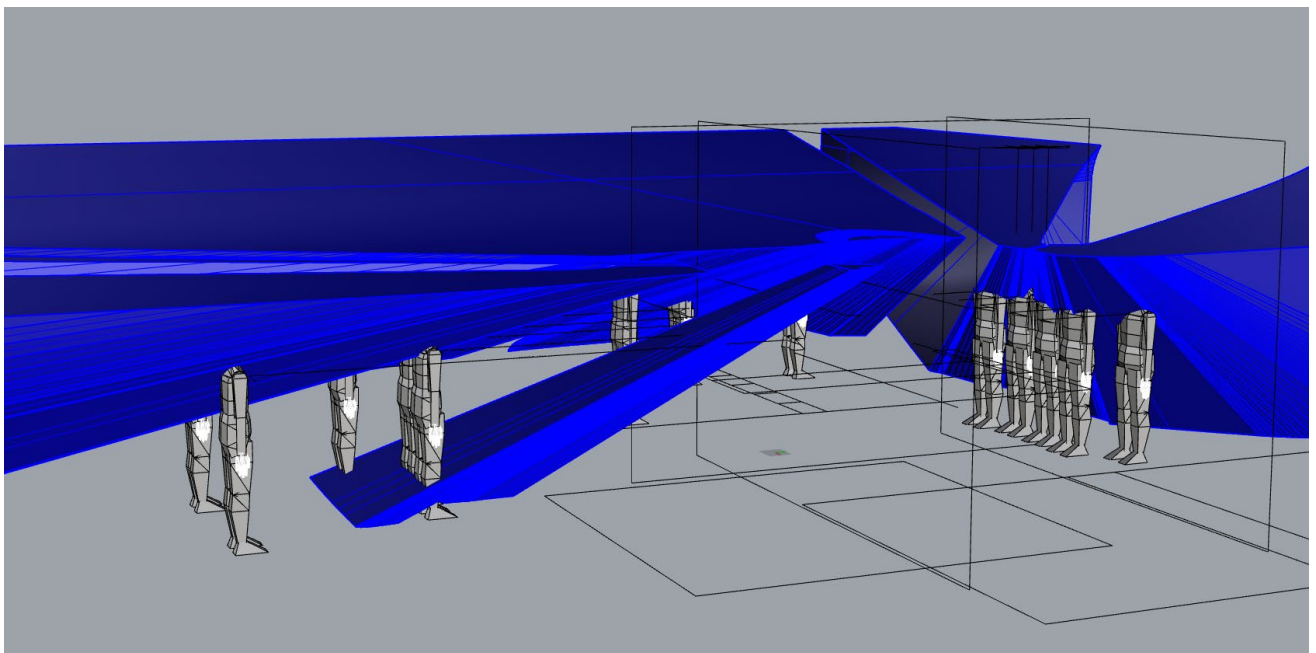

Figure 18. Intersection of the VRU simulations with the projection volumes. VRUs positioned such that the head and shoulders intersect with the projections and thus head and shoulders are visible in these locations.

The VRU assessment configuration is shown in Figure 19. Thirteen VRU simulations are positioned around the vehicle: three to the front and five to both the left and right of the cab. Each VRU is in a standing posture and is sized to a 5th %ile Italian female stature (1500mm high). This VRU height was selected as the Italian

female is the shortest population in Europe for the Anthropometric data set used in the project⁸, therefore, over 99% of the European adult population would be visible, if a 5thile Italian female is visible. The VRU array down each side of the cab is positioned in the X-axis with reference to the Front eye point (FEP). The far right VRU (see Figure 19) is offset from eye point by one body width. Each VRU to the left of the far right VRU is then offset from the adjacent VRU by 30mm. The front VRU array is aligned to the outside extends of the cab on the left and right-hand side, and the centre of the windscreen. In this manner the X-Axis position of the side VRU arrays, and the Y-axis position for the front VRU array, are consistently and repeatably positioned for each cab design. The performance of a vehicle in the VRU test is determined by the average VRU distance away from cab at which the head and shoulders can be seen by the driver where the side VRU arrays are moved in the Y-Axis only and the front VRU arrays are moved in the X-Axis only.

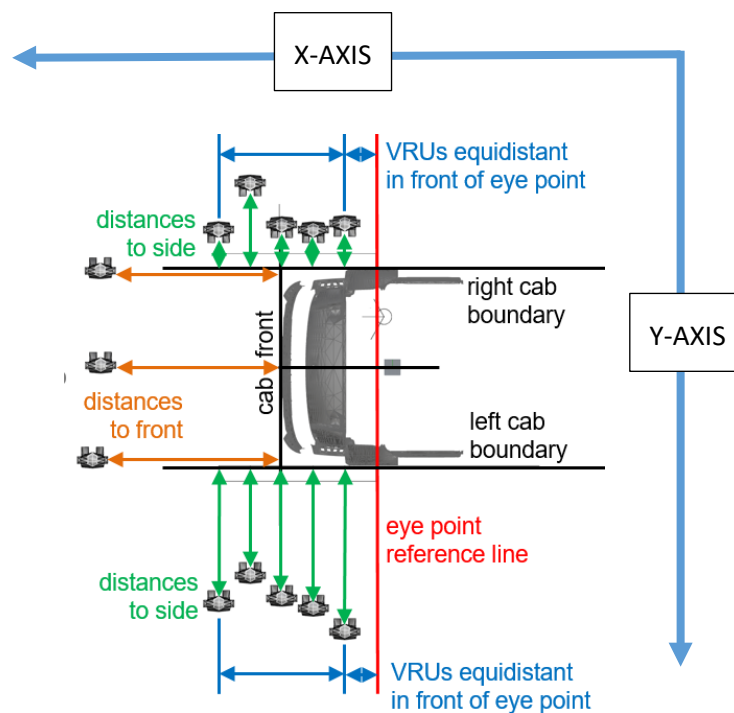

Figure 19. VRU simulations positioned around the vehicle to provide quantification of the volumetric analysis

9.2 VEHICLE SAMPLE

The definition of the sample of HGVs to be used in the project had two main requirements. The first was to ensure that the sample was sufficiently broad to ensure that any method developed for the evaluation of direct vision performance was capable of assessing all configurations of vehicles. The second was to assess the current most recent (Euro 6) HGVs on UK roads. During the course of the project these two requirements were combined, and it was decided that the most expedient approach was to evaluate the broadest range of vehicles representing all of the major manufacturers. The LDS team sourced sales data from the Society of Motor Manufacturers and Traders (SMMT) with the summary of sales number being produced as per Table 6.

⁸ PEEBLES, L. and NORRIS, B. 1998 Adultdata. The handbook of adult anthropometric and strength measurements - Data for design safety. (London: Department of Trade and Industry), DTI publication 2917/3k/6/98/NP URN 98/736.

Manufacturer	Sales
DAF TRUCKS	9,092
MERCEDES	5,989
SCANIA	5,837
VOLVO	5,281
MAN	3,570
RENAULT TRUCKS	2,589
IVECO	1,291
Dennis	821
Other	111

Table 6. Sales data for Category N3 trucks from SMMT

The final vehicle sample list included vehicles from all of the manufacturers listed in Table 6 and represented over 99% of the HGV fleet for Category N3 vehicles. The full list is shown in Table 7 below:

DAF	Dennis	Isuzu	Iveco	MAN	Mercedes	Volvo	Renault	Scania
DAF XF	Elite 6	Isuzu F120	Iveco Stralis	MAN TGX	Mercedes 2.5m Cab	Volvo FH	Renault T	SCANIA R
DAF CF				MAN TGS	(Actros, Arocs, Antos)	Volvo FM	Renault K	SCANIA P
DAF LF				MAN TGM	Mercedes 2.3m Cab	Volvo FMX	Renault C 2.5m Cab	
				MAN TGL	(Actros, Arocs, Antos)	Volvo FL	Renault C 2.3m Cab	
					Mercedes Atego	Volvo FE	Renault D	
					Mercedes Econic	Volvo FE LEC		

Table 7. Full vehicle sample evaluated in the development of the DVS

Note that the project only assessed Right Hand Driver (RHD) vehicle configurations.

9.2.1 VEHICLE CLASSIFICATION N3 VS N3G

One of the starting points of this research concerned the over representation of construction vehicles in KSI accidents between HGVs and vulnerable road users. HGVs designed for a construction role are designated as N3G. After a thorough review of the vehicle fleet it was determined that in all cases the cab of an N3G vehicle is identical to its N3 (distribution) variant in the features that would affect direct vision e.g. seating position (eye point), window apertures and dashboard. The only differences demonstrated by some manufacturers is the inclusion of modified mirrors and mirror mounting arms between the N3G and N3 variants, and additional bumpers and wheel arches. However, the largest differentiator between N3G and N3 vehicles was found to be their cab mounting height as shown in Figure 20.

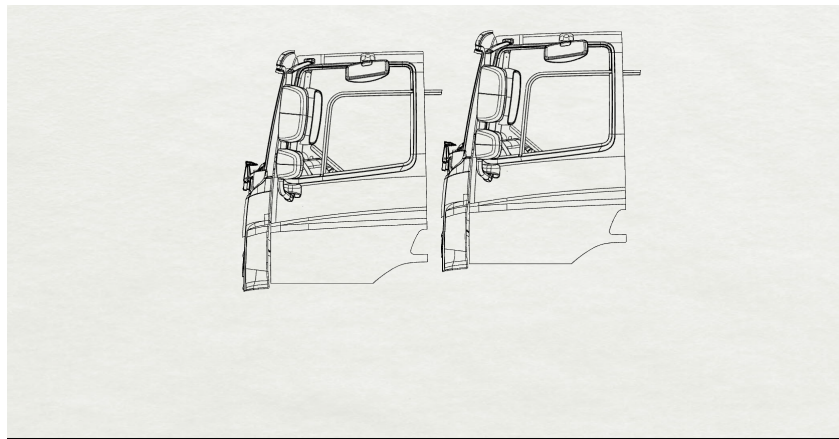

Figure 20. Mounting height difference between the lowest possible DAF CF N3 (left) vs the lowest possible DAF CF N3G (right)

9.2.2 CAB MOUNTING HEIGHT

For the majority of HGVs the cab can be mounted at different heights from the ground. There are a number of variables including axle configuration, suspension type, and tyre profiles that can affect this height. In addition, whether the vehicle is laden or unladen also has an effect. As an example, a single vehicle may have the ability to vary by 320 mm in height due to these variables.

Previous work by the LDS team as part of the Understanding Direct and Indirect Vision from HGVs project demonstrated that height correlates directly with direct vision performance as shown in Figure 21.

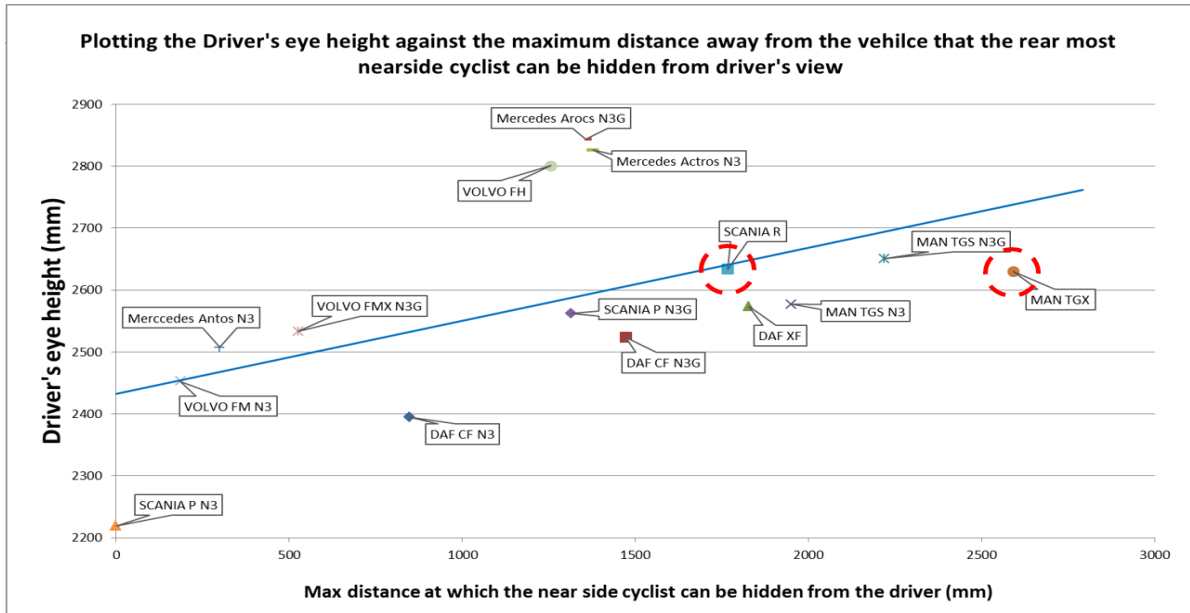

Figure 21. The comparison between the driver's eye height and the distance away at which a cyclist adjacent to the passenger door can be hidden from the direct vision of the driver

Thus, it was important that cab mounting height was addressed in the method and ultimately the DVS with an appropriate analysis sample selection. All vehicles were therefore evaluated at their maximum and minimum mounting heights, and at 1mm increments between these extremes. In some cases where the difference between minimum and maximum heights were large, this led to over 800 separate DVS results.

This provided a much greater understanding of the performance of the fleet and was ultimately important for defining the DVS.

When referring to maximum and minimum mounting heights the project used the unladen values. This was deemed appropriate as it represented the worst-case configuration. Later it was agreed that all vehicles should be rated by their proxy-average height as discussed in Section 11. Therefore, all vehicles were analysed for height values between the minimum and maximum heights at 1mm increments, with an additional 200mm height range to ensure that the proxy average height data would be available for all possible configurations.

9.2.3 3D VEHICLE DATA

The vehicle sample assessed during the project was ultimately obtained using two methods: 3D CAD data directly from manufacturers and data collected from 3D scanning of real vehicles. Ideally CAD data would have been obtained for all of the sample however data of this nature is commercially very sensitive, and it was understood that not all manufacturers would be willing or able to share these data. Manufacturers that were able to provide CAD data include: DAF, Dennis, Iveco, Mercedes, Renault and Volvo, manufacturers for which 3D scan data were obtained include: MAN and Scania. The following table highlights the type of data used for each manufacturer.

Make & model	CAD DATA	Height data
DAF CF N3, N3G (Highest, Lowest & Most Sold)	CAD data provided	All height range data
DAF XF (Highest lowest & most sold)	CAD data provided	All height range data
DAF LF	CAD data provided	All height range data
Dennis Eagle Elite 6	CAD data provided	All height range data
MAN TGS N3, N3G (Highest, lowest & most sold)	Scan data used	Body builder data used
MAN TGX N3, N3G (Highest & lowest)	Scan data used	Body builder data used
MAN TGL N2/N3 (Highest and Lowest)	Scan data used	Min/max only
MAN TGM N2/N3 (Highest and Lowest)	Scan data used	Min/max only
Mercedes 2.3 (Highest & lowest)	CAD data provided	Min/max only
Mercedes 2.5 (Highest & lowest)	CAD data provided	Min/max only
Mercedes Atego ((Highest & lowest)	CAD data provided	Min/max only
Mercedes ECONIC	CAD data provided	single height
Renault D 2.3 (Highest & Lowest)	CAD data provided	Min/max only
Renault C 2.5 (Highest & lowest)	CAD data provided	Min/max only
Renault K (Highest & lowest)	CAD data provided	Min/max only
Renault T RM (Highest & lowest)	CAD data provided	Min/max only
Scania P (Highest & lowest)	Scan data used	Min/max only
Scania R (Highest & lowest)	Scan data used	Min/max only
Volvo FE LEC (Most Sold)	CAD data provided	Min/max only
Volvo FE (Highest & lowest)	CAD data provided	Min/max only
Volvo FH (Highest & lowest)	CAD data provided	Min/max only
Volvo FL (Highest and Lowest)	CAD data provided	Min/max only
Volvo FM (Highest & lowest)	CAD data provided	Min/max only
Volvo FMX (Highest & lowest)	CAD data provided	Min/max only
Iveco Stralis	CAD data provided	All height range data

Table 8. Summary of the data obtained for the sample

9.2.3.1 MANUFACTURER CAD DATA

For the purposes of evaluation only the necessary CAD data were requested. These included:

- The internal vehicle cab structure with window apertures and seats. Including anything which may obscure the view of the driver e.g. the windscreen frit (fade off), windscreen wipers, dashboard, steering wheel, etc.
- The seat reference point (SgRP) or the R point
- The steering wheel to be in its neutral adjustment position
- The external vehicle cab structure including the basic external panels, mirrors and mirror mounting arms

Figure 22 shows an example of the data requested.

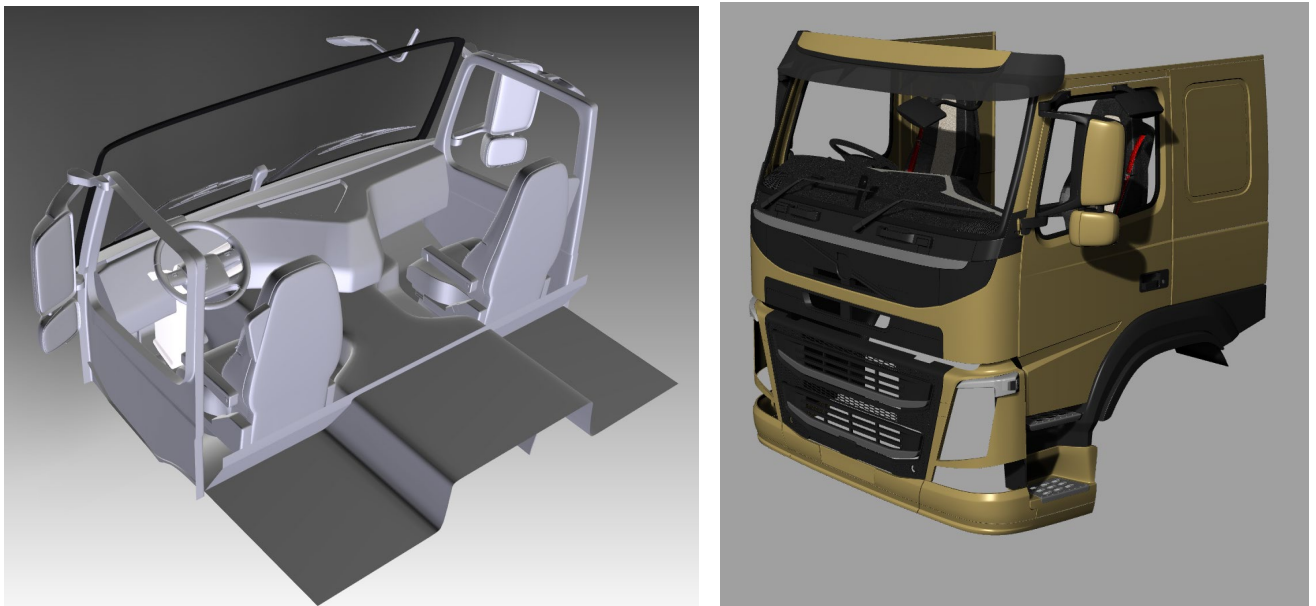

Figure 22. Exemplar CAD model of a HGV cab including the necessary elements for evaluation (left interior, right exterior)

9.2.3.2 3D SCANNED DATA

Scan data had to be obtained where manufacturer CAD data were not available. For the two manufacturers, MAN and Scania, scan data were already available for the Euro 6 models from previous work (see Figure 23 left). However, it was deemed important to refine these existing models through the additional capture of high-resolution data of the interior. Thus dashboards, A and B-pillars and relevant interior fittings (grab handles, rain sensors) were captured using a combination of Artec Eva and Artec Space Spider light-based scanners (see Figure 23 right). The additional data were integrated into the existing models to produce final assessment vehicles.

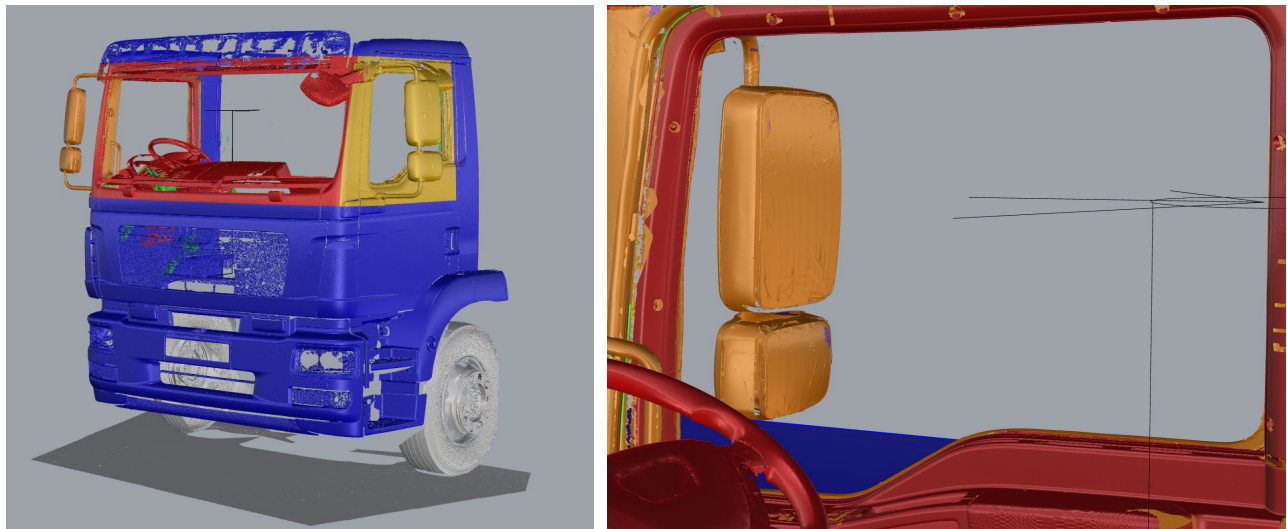

Figure 23. Existing scan data (left) augmented with additional interior scan data (right)

9.3 VEHICLE SET UP

Once data had been obtained either from manufacturers or via the scanning process each vehicle had to be prepared for evaluation. Setup included ensuring that the steering wheel was in its mid/neutral adjustment position, that passenger seats were fully rearwards, and wipers were in their parked position. The final and most critical element of the set-up process was the definition of an eye point.

9.3.1 EYE POINT DEFINITION

There are potentially many ways in which an eye point could be established for the projection of the field of view. Previous work by the LDS team⁹ utilised digital human models in the SAMMIE DHM system of different sizes including: 5th %ile UK female and 50th and 99th %ile UK Male, with their hip point located at the standard seating reference point (SgRP) and placed in a driving posture. These eye points were subsequently validated against Reed's eyellipse data (2005¹⁰) for HGVs with height adjustable seats. The initial approach considered for the DVS project was to employ Reed's method again, however with input from relevant stakeholders it was decided that wherever possible existing standards should be utilised as these would be familiar to those in the industry and are already factored into vehicle design and evaluation by manufacturers. Furthermore, any specification of an eye point should be as simple as possible to minimise error and aid ease of use of the standard.

The definition of an eye point required consideration of three main factors:

- Vertical (Z) position relative to the SgRP to account of the height of the driver
- Horizontal (X/Y) position relative to the SgRP to account for the direction of view of the driver
- Whether a single (monocular) or double eye ((am)binocular) point(s) would be used

⁹ SUMMERSKILL, S. ...et al., 2015. Understanding direct and indirect driver vision in heavy goods vehicles: Final report prepared on behalf of Transport for London. Loughborough: Loughborough University, pp. 1-432.

¹⁰ Reed, M.P. (2005). Development of a New Eyellipse and Seating Accommodation Model for Trucks and Buses. Technical Report UMTRI-2005-30. University of Michigan Transportation Research Institute, Ann Arbor, Michigan.

For the vertical position it was decided to adopt the eye point definition derived from UNECE Regulation 46¹¹ which states a driver's ocular point(s) as being "635mm vertically above the point R [SgRP] of the driver's seat". For the horizontal position it was decided to adopt the eye point definition derived from SAE J1050¹² which allows for a "head turn about a vertical axis (of) a maximum of 60 degrees to the left or to the right from the straight ahead position." as shown in Figure 24. In order to position the 60 degree rotation a neck point was also defined, again using SAE J1050. This defines the neck point (P) as 98mm rearwards of the mid point between the left and right eye points (E) shown in Figure 24.

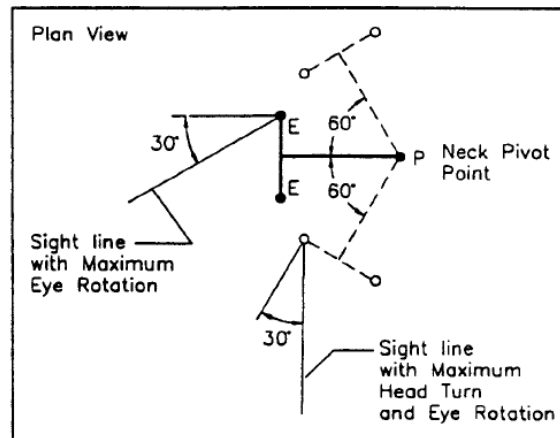

Figure 24. Sight lines and eye point rotation from SAE J1050.

However, on review of the SgRP data supplied by the manufacturers, it was noted that the definition of the SgRP varied significantly, contrary to how the SgRP is defined in the automotive industry. This led to significant variability across manufacturers and thus the volumetric assessments were not just a function of cab design but also the interpretation of the SgRP which was deemed unacceptable as this provided certain manufacturers with an advantage over others.

Therefore, a new method for the definition of the eye point was required. The criteria for this new definition were as follows;

- The eye point definition should be achievable in all current designs.
- It should present a fair and equitable method that can be easily applied by all manufacturers

The first part of the process that was followed to define the new eye point examined the potential to define a single hip point which could be achieved by all existing vehicles, which would replace the SgRP used in the previous method. To this end all of the H-Point envelopes for the vehicles in the sample were overlaid with reference to a common Accelerator Heal Point (AHP) definition shown in Figure 25. This showed that there was a common h-point area that could be met by all vehicles designs.

¹¹ UN ECE Regulation 46 – Revision 6 (2016). Uniform provisions concerning the approval of devices for indirect vision and of motor vehicles with regard to the installation of these devices. UN ECE Vehicle Regulations. 2016.

¹² SAE J1050 (2009). Describing and Measuring the Driver's Field of View. SAE Surface Vehicle Recommended Practice. SAE International.

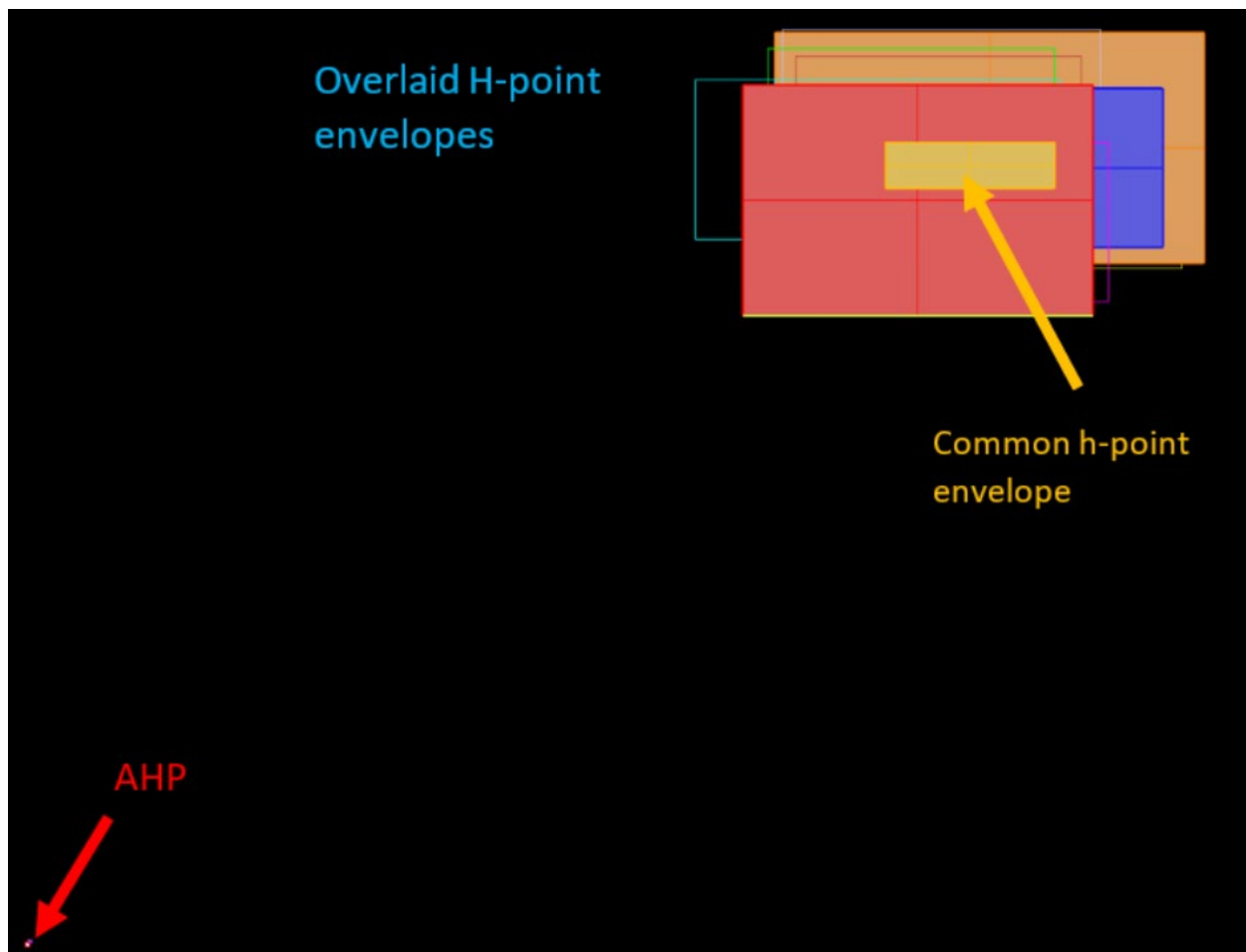

Figure 25. The plotting of all H-point envelopes to determine a common area of application

This process showed that there was a common area in all of the H-point envelopes. The process for defining a hip point within the common h-point envelope was then explored using calculations derived from SAE J1516: Accommodation Tool Reference Point for Class B Vehicles, SAE J1517: Driver Selected Seat Position for Class B Vehicles - Seat Track Length and SgRP, and the from the work of Matt Reed (2005): Development of a new Eyellipse and Seating Accommodation Model for Trucks and Buses. All approaches define an offset from the Accelerator Heel Point (AHP) to a h-point, notably the Accommodation Tool Reference Point (ATRP) that can vary in position based upon a supplied H30 value (vertical offset between the AHP and the Hip point).

SAE J1516 and J1517 use the following equations for a 90:10 Male:Female ratio:

$$x = 855.31 - 0.509z \quad 50^{\text{th}} \text{ \%ile (SAE J1516)}$$

$$x = 922.49 - 0.494z \quad 95^{\text{th}} \text{ \%ile (SAE J1517)}$$

The equations were used to plot the hip point location lines for a series of points between the maximum and minimum H30 values.

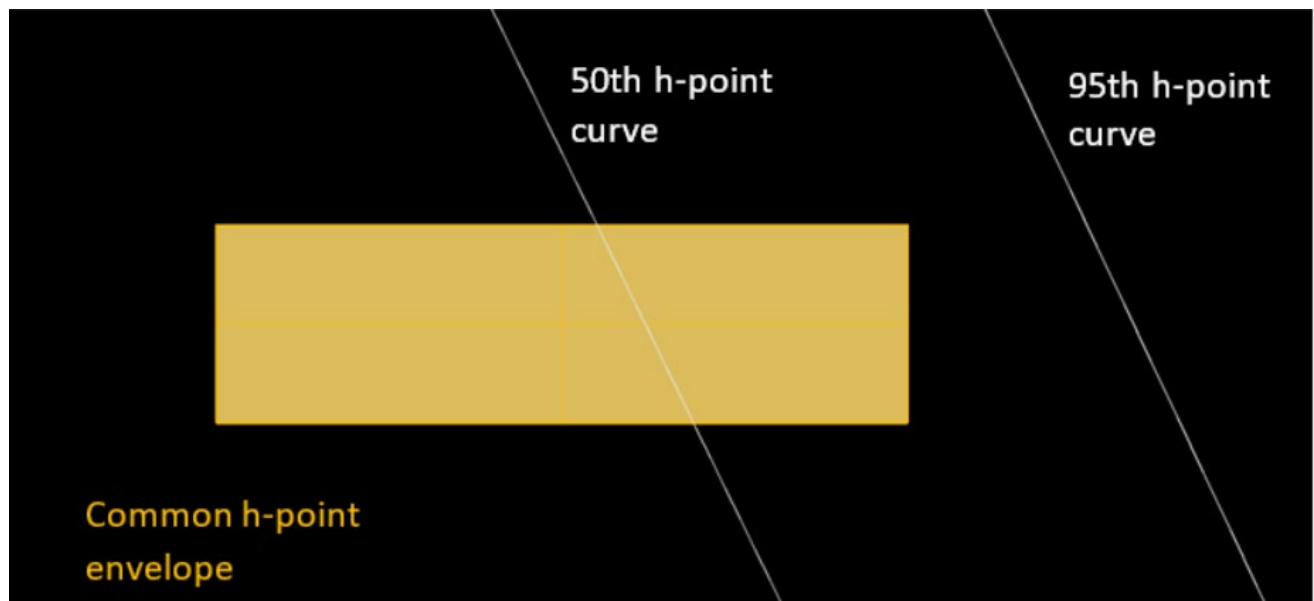

Figure 26. The plotting of the 50th and 95th H-point curves and the intersection with the common H-point envelope

As can be seen from Figure 26 above, the 95th h-point curve does not coincide with the common h-point envelope and so the 50th h-point curve was used.

The intersection of the 50th percentile h-point curve and the common h-point envelope was then used to define a single reference point. As the h-point curve was based on 50th percentile anthropometry the midpoint between the maximum and minimum common H30 (z) values was used as shown in Figure 27.

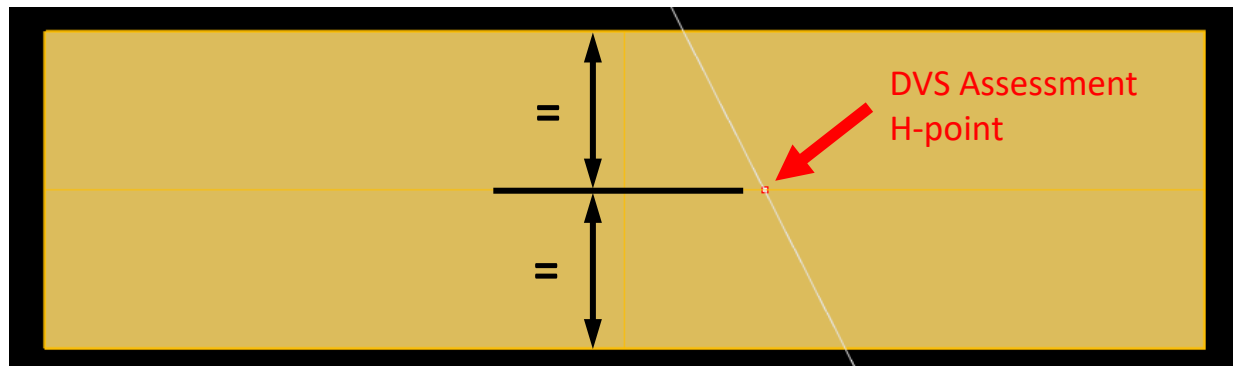

Figure 27. The selection of the location within the common h-point envelope using the 50th percentile h-point curve

One of the criticisms of J1516 / J1517 is that the steering wheel used when deriving the method was in a fixed position and the heights of the H30 values used do not extend as high as current vehicles. In order to address this Reed (2005) proposed a modified version of that contained in J1516. In order to understand the implications of the updated methodology, the points defined by the Reed process were overlaid onto those of J1516. As the Reed method requires the identification of the mid-point of the steering wheel adjustability it defines a series of discrete points rather than a line. These points are the centroid of a h-point accommodation ellipse with a 90:10 Male:Female split as above and so can be equated to the h-point of the 50th percentile of the 90:10 split shown above from J1516.

Of the three vehicles assessed the points generated from Reed's (2005) methodology in relation of that of J1516 are shown below:

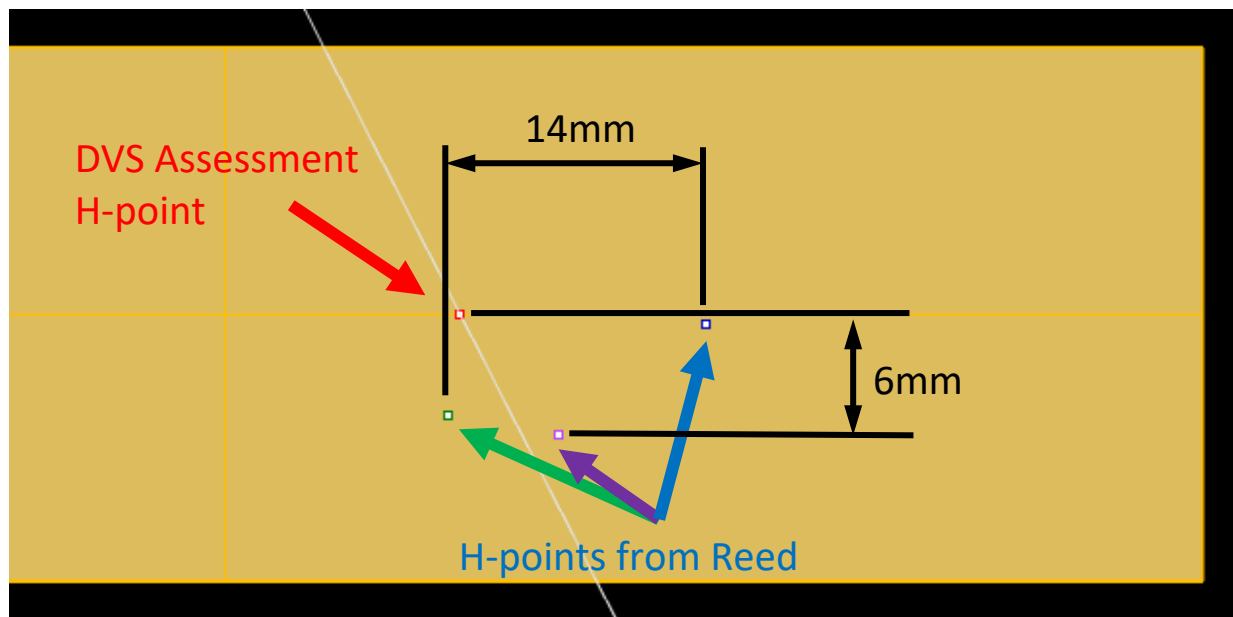

Figure 28. The points generated from Reed's (2005) methodology in relation of that of J1516

As shown in the figure there is good correlation between the points generated using both methods. It was therefore proposed to use the simpler definition in SAE J1516 to define the DVS assessment H-point (DAHP). There are both positives and negatives to the approach taken for the definition of the common H-point that were discussed extensively over a number of meetings of the stakeholder group. The method as defined does provide the definition of a single H-point which can be consistently used by all manufacturers. But does provide some variability with regard to relative position in each manufacturer's H-point envelope. The method was seen as a pragmatic compromise by the vehicle development teams that were part of the stakeholder group. The new H-point definition was accepted by all.

With a H-point defined it was then determined where the front eye point (FEP) location would be with reference to the DVS assessment H-Point. The average European eye height above hip-point (Z-axis), and rearwards offset between the hip and eye location (X- axis) was defined with a back rest angle of 18 degrees (as agreed by the stakeholder group and defined as a mid-point in the variability in back rest angle used for the driving position as defined by each manufacturer) and the average value was found for 50thile digital human models. The sample included 50thile male and female offsets identified for UK, Germany, Holland, France, Italy and Sweden (See Figure 29, data source Peebles 1998¹³) and then this was averaged with a 90:10 male female split to reflect the proportion of male and female drivers that was acceptable to the stakeholder group which reflects the values used in other standards. The result is an eye point that is 673.5mm above the h-point and 71.9mm rearwards of the hip point in X.

¹³ PEEBLES, L. and NORRIS, B. 1998 Adultdata. The handbook of adult anthropometric and strength measurements - Data for design safety. (London: Department of Trade and Industry), DTI publication 2917/3k/6/98/NP URN 98/736.

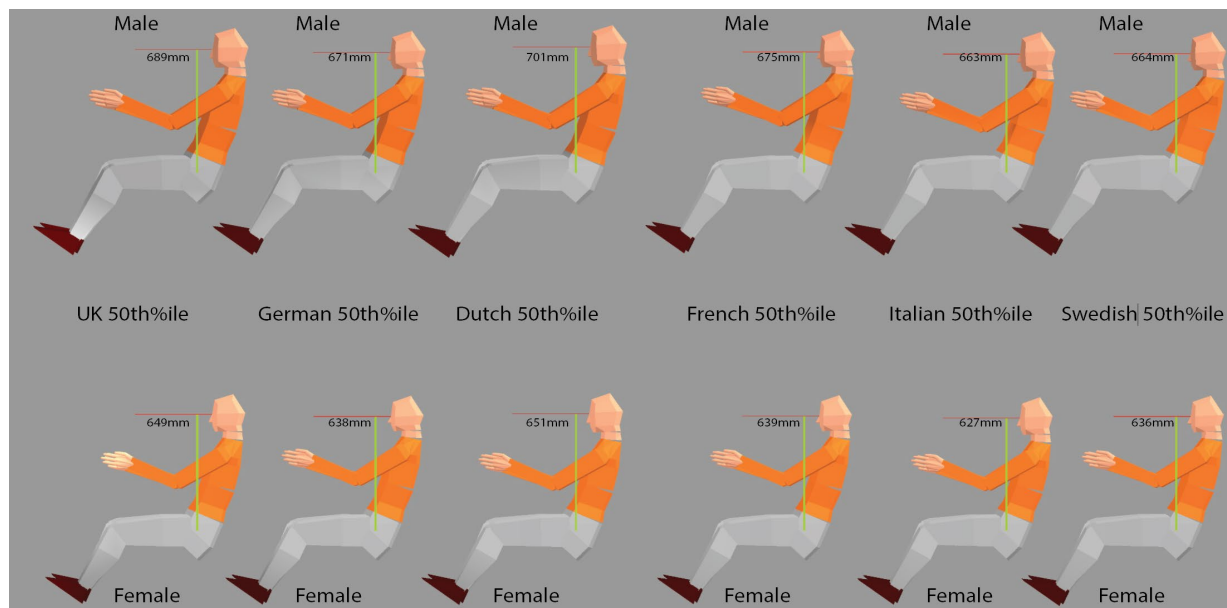

Figure 29. Defining the FEP using DHMs that represent average sized Europeans from the UK, Germany, the Netherlands, France, Italy and Sweden with a 90:10 male female split

Therefore the proposed eye point is 1163.25mm above the AHP and 678mm rearwards of the AHP. This single point would be used for all vehicles and used in the testing. With the FEP defined the analysis went on to explore whether the eye points used would be binocular, ambinoocular or monocular. Both Regulation 46 and J1050 define two ocular points (eye points) and so the impact of using binocular, ambinoocular or monocular vision had to be carefully considered. An ambinoocular assessment is arguably the truest representation of human sight and has the potential to recognise designs of features such as a-pillars that may have been optimised for binocular vision. However, the concern raised by stakeholders was the complexity of the projection process when combined with an ambinoocular process.

With two eye points and three head positions (forward, left and right as per Figure 24) a total of six projections are required. These projections would then need to be combined to create a composite projection. In evaluating this possibility two issues arose:

The first issue concerned what would be projected from each eye point. In its simplest form this would restrict each of the three eye points to only project through the window to the relevant side. Thus the eye point at the position of 60 degrees to the right would only be used to project through the driver's side window. The eye point straight ahead only used for the windscreen and the eye point 60 degrees to the left used to project through the passenger side window. However, in limiting the eye points in this manner much of the benefit of binocular vision is removed. Ideally the field of view from an eye would be the limiting factors for what is projected. Figure 30 shows the three views for an exemplar vehicle. This image shows that in each case it is possible to see through adjacent window apertures. Thus, for the left view the projections could be produced for both the passenger side window, but also for part of the windscreen. This raises two difficulties, the further proliferation of projections, and also how to project a partial view. The projection could be constrained by the angular field of view of an eye and / or the limits of movement of a human eye. The result is a potentially complex process for generating a projection, for which standard CAD tools are not currently available.

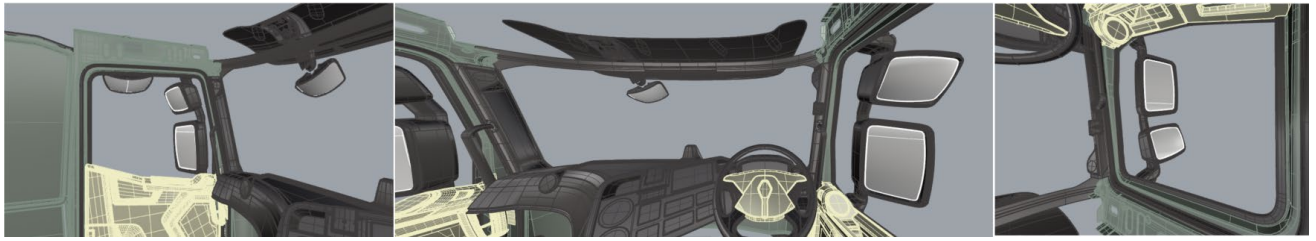

Figure 30. Left, front and right views from the three proposed eye points for evaluation

The second issue is then the management of multiple projections. If three projections are used from a single eye point in each case and limited to the aperture in the direction of view, the projections produce three discrete non-intersecting projections as shown in Figure 31.

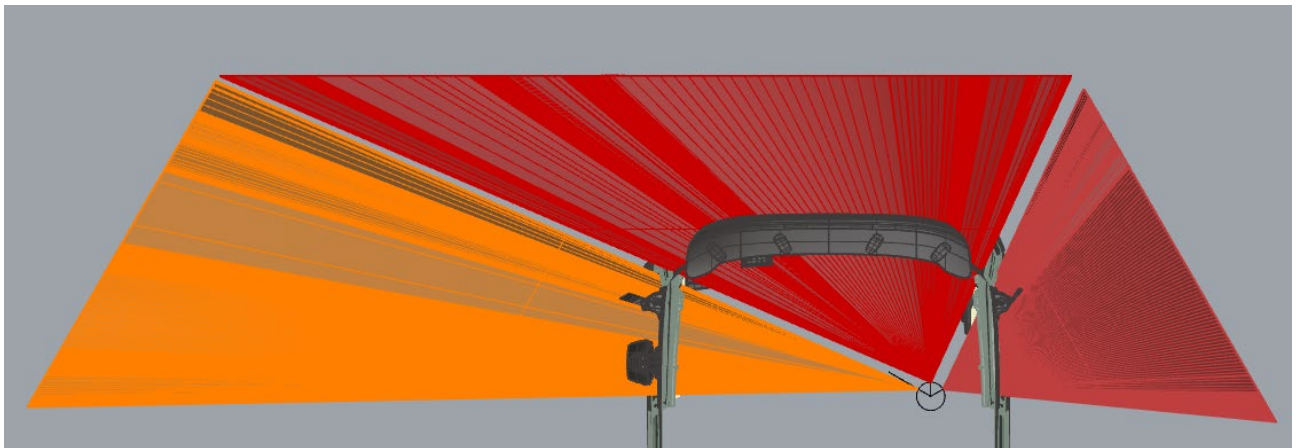

Figure 31. Three projections from three eye points, one each for the passenger side, windscreen and driver's side

If more projections are produced from two eye points the projections can intersect as shown in Figure 32. Once projections intersect the complexity increases as the projections have to be combined to generate a composite projection in order to calculate a single volume that does not include areas of overlap and thus double counting of volume. In tests performed by the LDS team and by one of the manufacturers (Volvo), the process of combining the projected volumes was extremely complex and time consuming. In some cases projections could not be combined using standard CAD tools and had to be manually rebuilt using surface modelling.

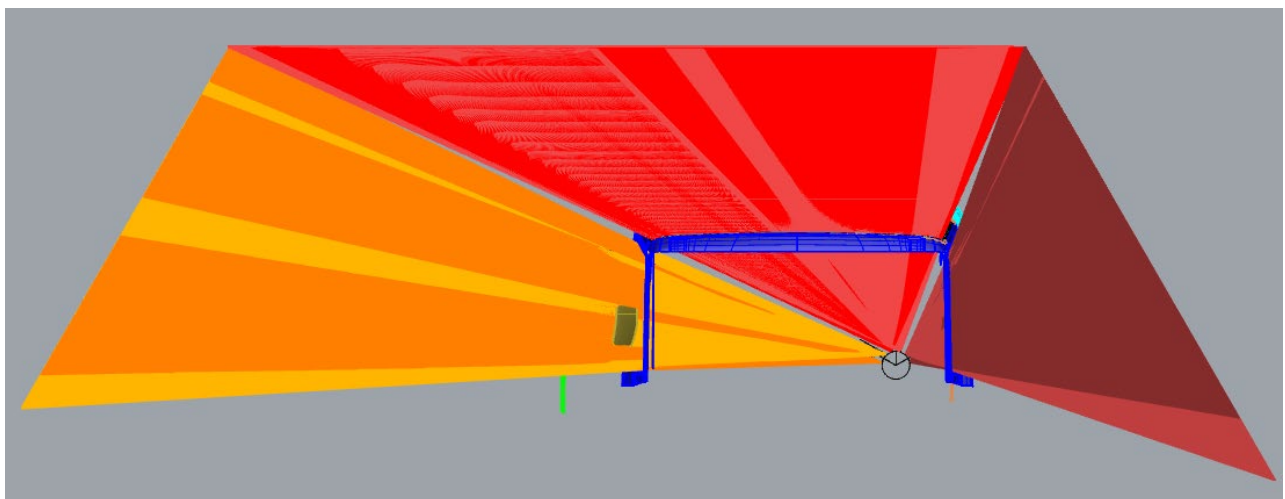

Figure 32. Six projections from six eye points, two each for the passenger side, windscreen and driver's side

The result of this evaluation was the decision to prioritise a monocular projection with agreement from the majority of manufacturers.

The final eye point definition used in the method to evaluate the direct field of view is shown in Figure 33.

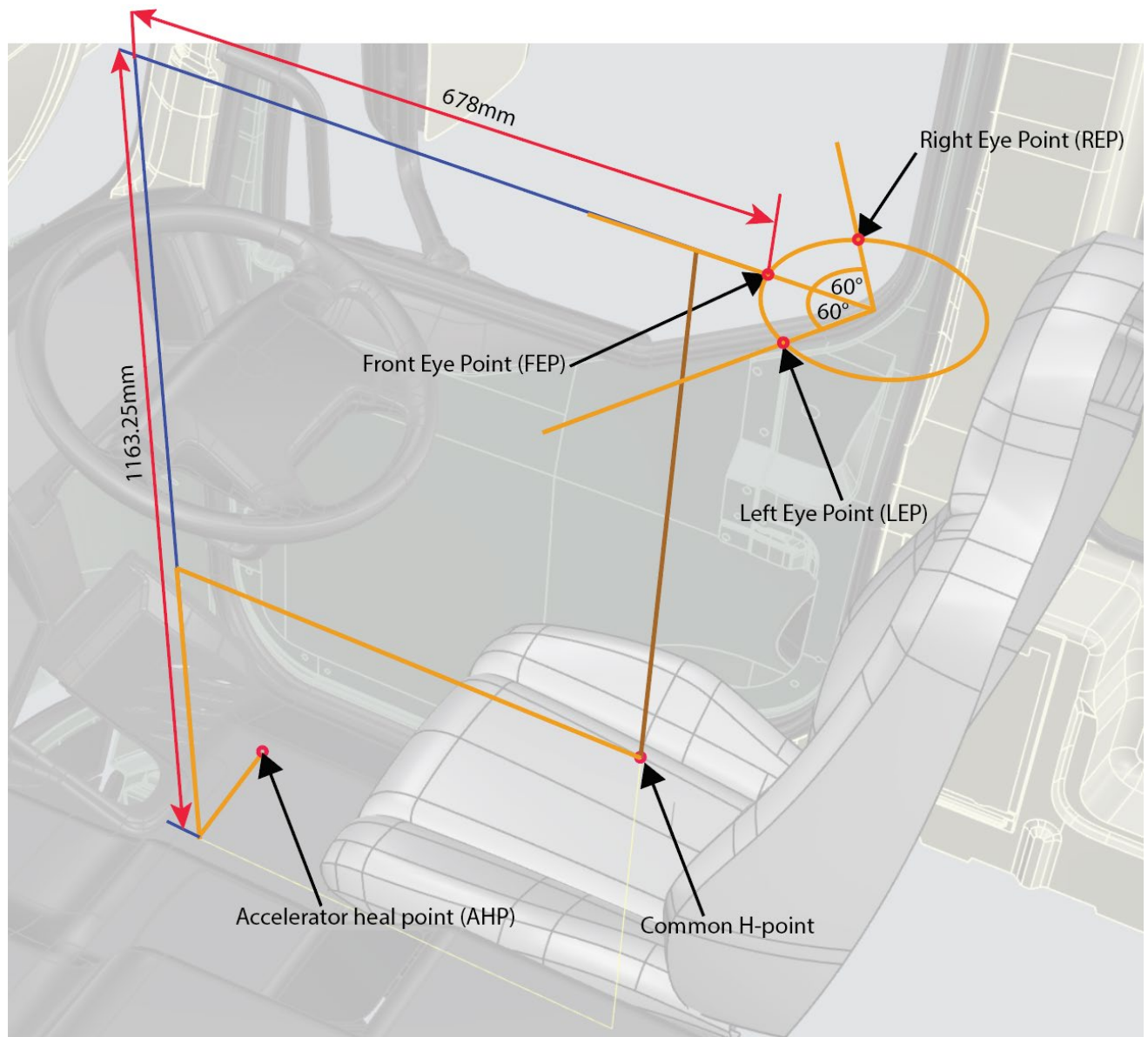

Figure 33. The final eye point definition (eye rig)

9.4 THE DEFINITION OF THE ASSESSMENT VOLUME

The volumetric projections can theoretically extend for any distance beyond the cab of the vehicle. In the Draft TRL DVS the initial proposal was to constrain the projections to a defined assessment volume. A key part of this project was to explore potential assessment volumes and justify the most appropriate candidate.

During the iterative development of the DVS a number of assessment volumes were evaluated. These varied in size, their position around the vehicle and whether the volume was subdivided to allow different weightings to be applied to different zones. The results from the evaluations were then compared to understand the implications of the different assessment configurations. The final selected assessment volume is documented in Section 9.4.1, the alternatives explored are documented in Appendix B.

9.4.1 THE VERTICAL SPECIFICATION OF THE ASSESSMENT VOLUME

The assessment volume is defined by a single volume that extends from 1.602m to the ground. It was deemed important for the assessment volume to extend to the ground, unlike the Draft DVS proposal, to account for smaller VRUs such as children and to challenge future designs to attempt to maximise direct vision. The height is specified to provide an assessment of visibility from the ground to a height representative of the tallest European population. The shoulder height of the Dutch Male population was used on the premise that seeing the head and shoulders of a person would allow them to be recognised by the driver. This resulted in an upper limit value of 1.602m as shown in Figure 34.

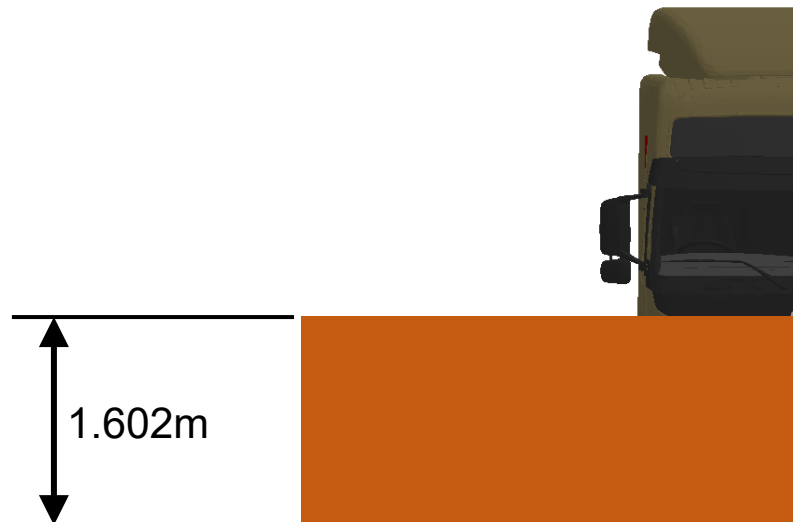

Figure 34. The vertical specification of the assessment zone

9.4.2 THE HORIZONTAL SPECIFICATION OF THE ASSESSMENT VOLUME

The layout of the assessment volume is primarily defined by the exterior surfaces of the cab offset by specific distances to the front, passenger and driver's sides. The selected version adds a volume to the driver's side that was originally omitted from the Draft TRL DVS. The zone extends to the passenger side by 4.5m, to the driver's side by 2m, to the front by 2m, and 1m to the rear of the eye point as shown in Figure 35.

The zone is defined by the areas around the vehicle in close proximity in which accidents with VRUs are known to occur. Whilst it is acknowledged that this would not then account for direct vision issues further away from the cab it prioritised the main focus of the research on direct vision of VRUs in the area of greatest risk, the zones adjacent to the cab as identified in the accident data. The limits to the left, right and front of the cab were defined by the coverage of the mirrors, as defined in Regulation 46. The Class V mirror has a requirement (for mounting heights above 2.4m) to be able to see a zone 4.5m from the passenger side of the cab at ground level. The Class VI mirror needs to be able to see a zone 2m to the front of the cab. There is no equivalent mirror for the driver's side but it was considered appropriate to extend the 2m requirement from the front to also cover this area. Whilst it may seem counter-intuitive to use an indirect vision requirement to specify a direct vision standard it provides a rationale for how far direct vision should be assessed from the vehicle. If current vehicles are designed such that mirrors are required to cover up to 4.5m from the passenger side of the cab it follows that direct vision should be afforded beyond this distance. The direct vision standard aims to remove the reliance on mirrors and thus should focus on providing direct vision of the areas currently covered by mirrors.

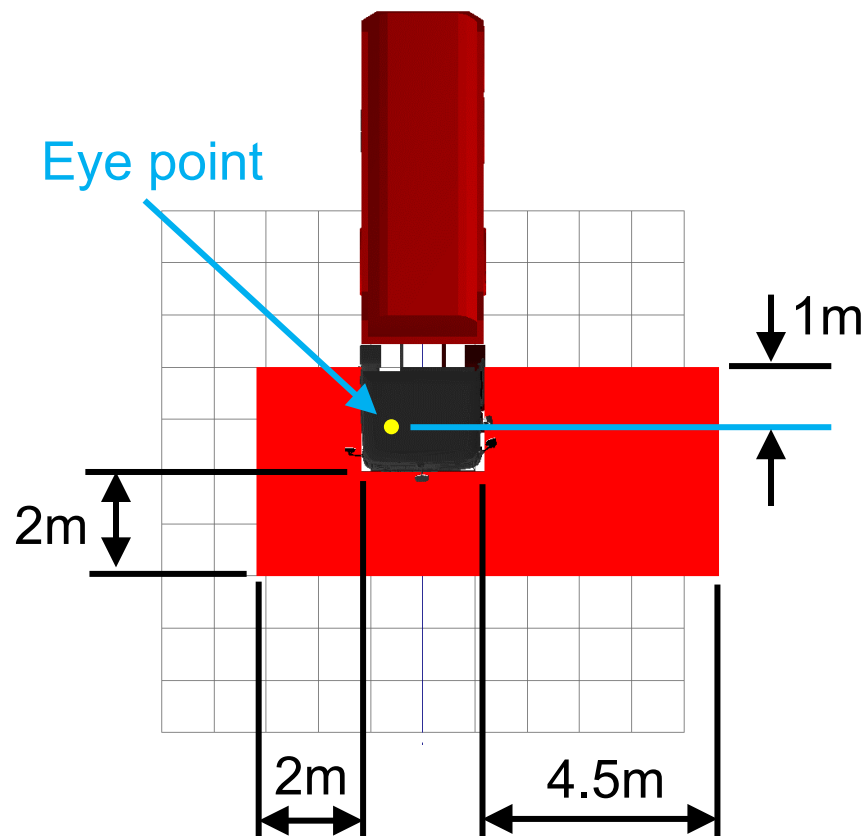

Figure 35. The horizontal specification of the assessment zone

9.5 RESULTS OF THE VOLUMETRIC PROJECTIONS

The following sections present the results from the application of the volumetric assessment of field of view as described in Section 9.1.1 and Section 9.1.2 applied to the assessment zone described in Section 9.4.

9.5.1 VOLUMETRIC RESULTS FOR ALL VEHICLES

Figure 36 shows the volumetric results for all vehicles for the assessment volume described in Section 9.4

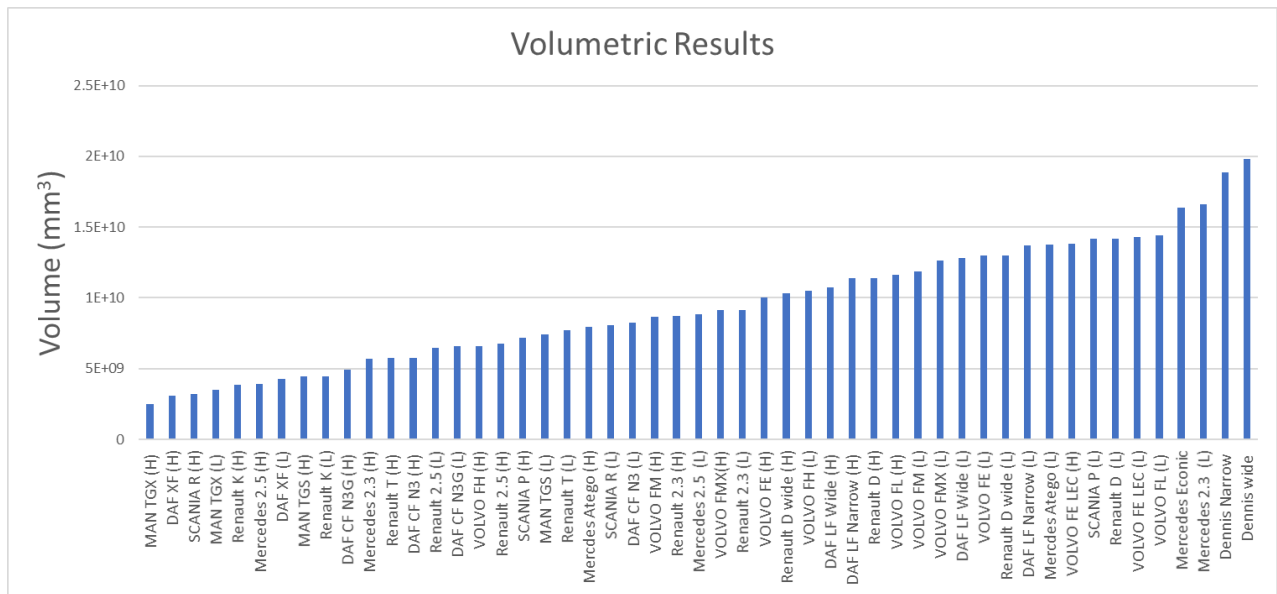

Figure 36. Results for the volumetric assessment

9.5.2 CORRELATION OF ASSESSMENT ZONE VOLUMES AGAINST VRU DISTANCE

As described in Section 9.1.3 the volumetric results were then compared to the results from the VRU analysis. As shown in Figure 37 the use of the VRU simulations provided a quantification of the volumetric results. For example, the Dennis Eagle Wide exhibited a volumetric result of $1.98 \times 10^{10} \text{ mm}^3$. The volume itself is then placed into a real-world context such that the average distance at which the head and shoulders of a 5th %ile Italian female is visible to the driver is 0.45m. Conversely the MAN TGX at its highest mounting height (H) achieved a volumetric result of $2.48 \times 10^9 \text{ mm}^3$ which equates to a VRU performance such that the average distance at which the head and shoulders of a 5th %ile Italian female is visible to the driver is 3.84m.

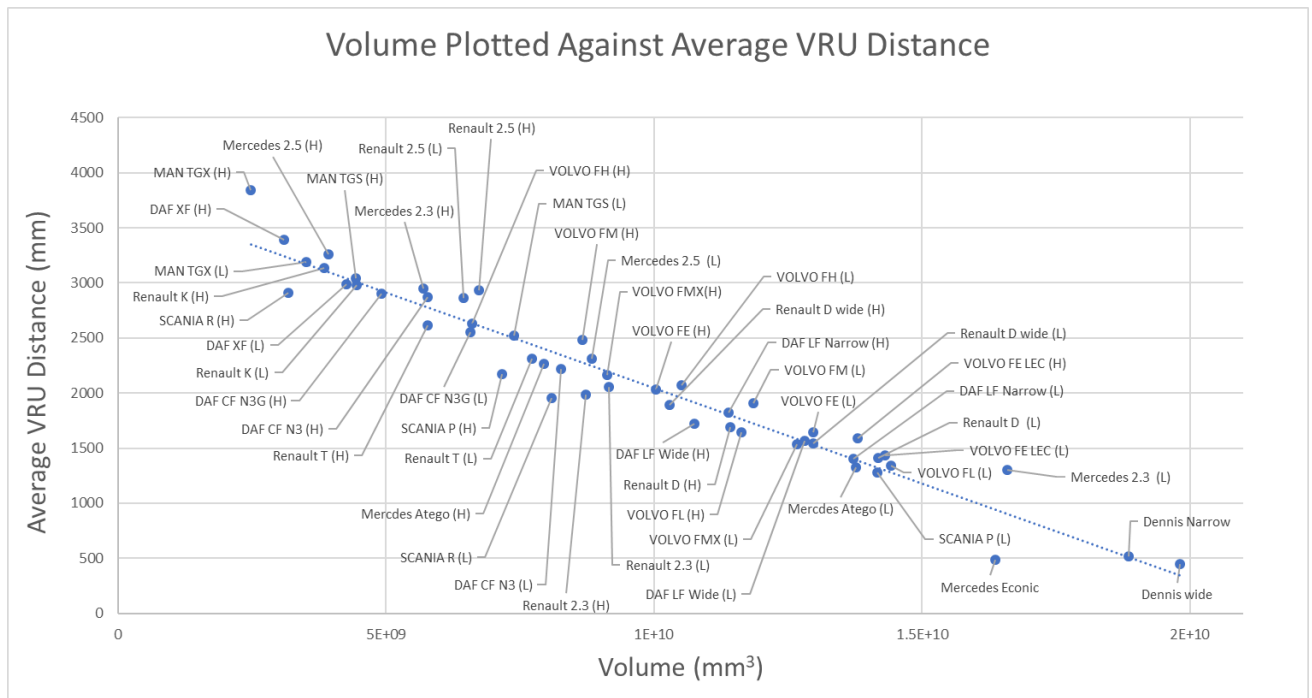

Figure 37. Graph showing the volumetric results correlated with the average distance of the 13 VRU simulations

9.6 THE DEFINITION OF THE STAR RATINGS

Once the results of the volumetric evaluation had been collated and these quantified with the VRU analysis the next stage was to define the star rating scheme. The aim of these ratings was to define a minimum performance threshold (zero / one star boundary) and a number of performance differentiator bands up to a maximum of five star.

It was considered important that the pseudo real world evaluation embodied in the VRU analysis be used to define the minimum threshold of acceptability regarding the position(s) around a vehicle in which a VRU can be located and be visible to the driver. Through discussion with the stakeholder group and the TfL team a process was defined for the production of four possible ways in which the DVS could be defined. These four candidates would have two variants each of an 'Absolute approach' and a 'Relative approach' and these are detailed in full in Appendix B.

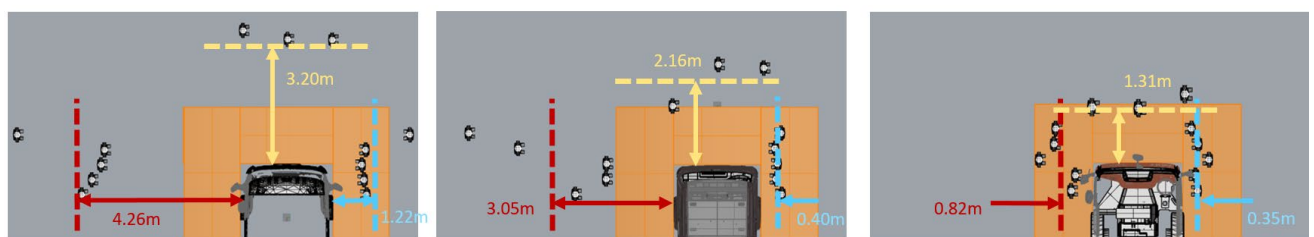

Figure 38. Images show average distances VRUs can be seen to each side of the cab for three vehicles

The VRU analysis of each vehicle provided the distance away that the VRUs could be placed (as per Figure 38) whilst being able to see the head of shoulders of the human as discussed in Section 9.1.3. These results were processed to see how many vehicles allowed the 5th %ile Italian female VRU to be seen to intersect with volumetric projection within the assessment zone. The concept here was that if a VRU cannot be seen within the assessment zone (which also covers the area that can be seen in mirrors) then there would be locations around the vehicle that would allow the VRU to be invisible to the driver, as they would potentially be between the volume of space that is visible to the driver through windows and the mirrors. Effectively they would be in a blind spot. Figure 39 shows an example of a truck cab with a low volumetric projection total (anonymised) which does not allow the head and shoulders of the VRU to be seen. What this means is, a small person cannot be seen directly through the windows when they are 4.5m to the passenger side of the driver's cab, or 2m in front of the driver's cab, and they cannot be seen through the mirrors. If this person moved closer to the truck, they still would not be seen through the windows, but they may be seen in the close proximity mirrors (Class V and VI), if the driver looks in those mirrors at the right time. The situation where a blind spot of this sort exists was seen as unacceptable, and therefore any vehicle which cannot allow, as a minimum the head and shoulders of a small Italian female (5th%ile) to be visible at the edge of the assessment volume will be considered inappropriate to use in an Urban environment and therefore will have a rating of zero star. This establishes a limit of acceptability.

In Figure 40 we see a vehicle with a high volumetric projection total (anonymised) which allows the head and shoulders of small Italian female (5th%ile) to be visible when she is 450mm from the front of the truck and 200mm from the passenger side of the truck. This demonstrates the result for a high vision cab which can allow small adults to be visible to the driver even at close proximity to the side of a vehicle. The results for the whole sample varies between these two extremes.

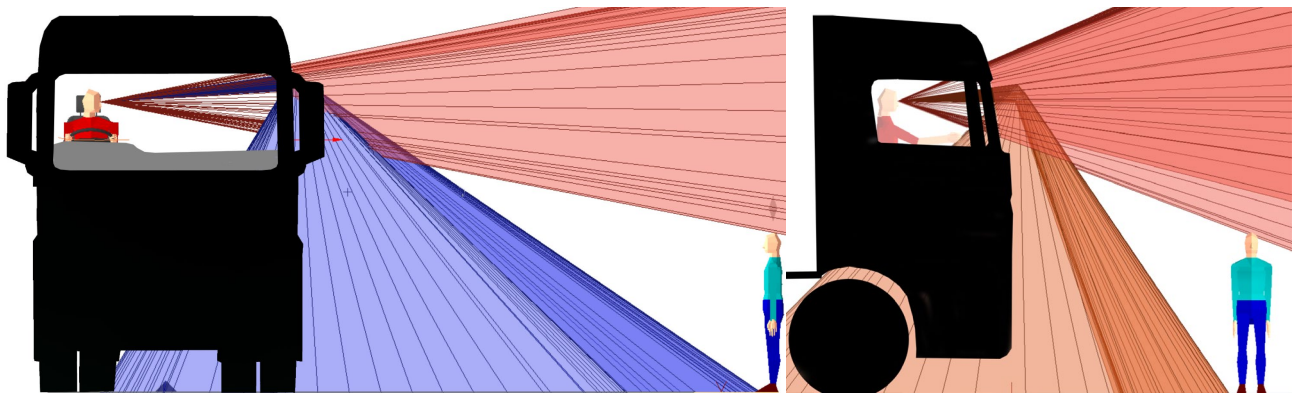

Figure 39. An example of a cab design which does not allow a small Italian Female (5thile) to be visible. The red projection shows the volume of space visible to a driver through the window. The purple and orange projections show the volume of space visible to a driver through the class V and class VI mirrors respectively.

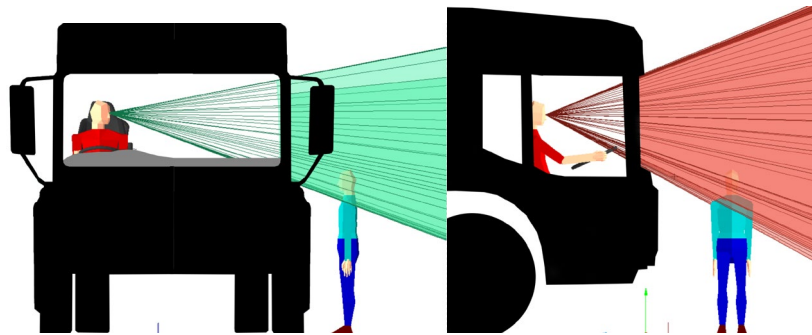

Figure 40. An example of a cab design which does allow the head and shoulders of a small Italian Female (5thile) to be visible within the assessment volume. This shows the result for the cab which achieved the highest rating in the DVS assessment

9.6.1 STAR RATINGS: ZERO TO FIVE STAR

The approach for defining the five star ratings is summarised in Appendix C. The approach is defined by the combined performance of all three of the areas around the cab, with the 1 star rating boundary being defined by direct vision performance in the VRU test.

The benefits of this approach are that the VRU distances have been used as a performance metric to identify a volumetric score which equates to a star boundary for each the three directions separately. This uses the VRU data to help quantify the results, but does not require VRU testing in the future application of the standard.

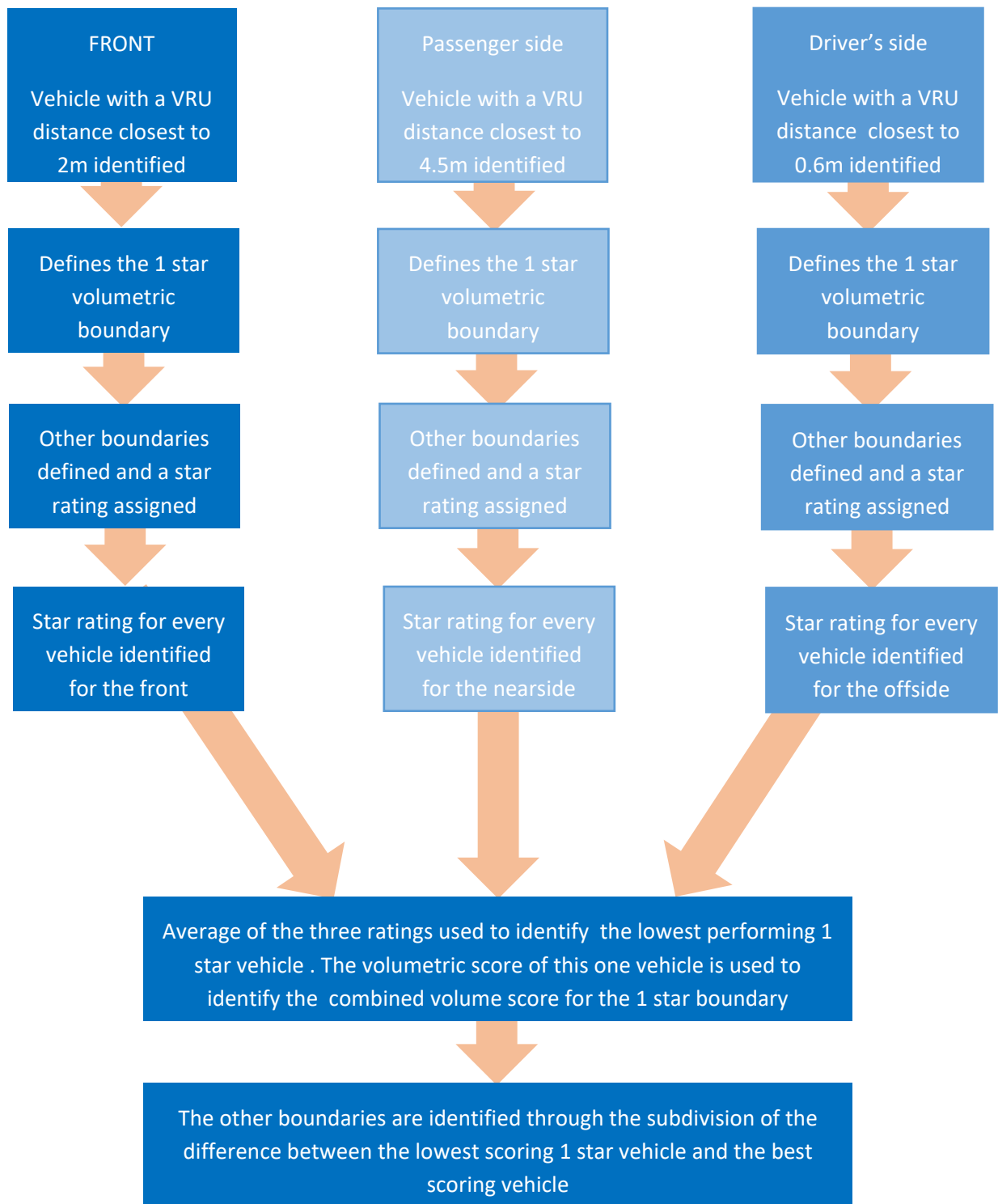

Figure 41. A flow chart illustrating the process used to create the star boundaries

The selected option (option 3 in the Appendix B) resulted in the boundaries shown below. The 1 star boundary is defined by the ability to see the head and shoulders of a 5thile Italian female at an average distance of 4.5m to the passenger side, 2m to the front, and 0.6m to the driver's side of the cab. Figure 42 shows the total volumes plotted against the average VRU distances with a correlation of $r=0.97$ (Pearson's correlation coefficient where $r=1$ is perfect, correlation scores above $r=0.5$ are considered strong). Figure 43 shows the total volumes only and Table 9 shows the raw data.

Rating	Make, Model (and height)	Total volume (mm ³)
5 Star	Dennis Eagle Elite 6 wide	19813840293
5 Star	Dennis Eagle Elite 6 Narrow	18853555211
5 Star	Mercedes Econic Bus door (H)	1.83E+10
4 Star	Mercedes 2.3 (L)	16589904045
4 Star	Mercedes Econic Bus Door (L)	16368311421
4 Star	Mercedes Econic Slam Door (L)	1.60E+10
3 Star	Mercedes Econic Slam door (H)	1.50E+10
3 Star	VOLVO FL (L)	14500510638
3 Star	Volvo FE LEC (L)	14474156267
3 Star	Renault D (L)	14234980078
3 Star	SCANIA P (L)	14165325539
3 Star	Volvo FE LEC (H)	13967653800
2 Star	Mercedes Atego (L)	13769578327
2 Star	DAF LF Narrow (L)	13727381203
2 Star	Renault D wide (L)	13129996278
2 Star	VOLVO FE (L)	13115030951
2 Star	DAF LF Wide (L)	12811626518
2 Star	VOLVO FMX (L)	12663603226
1 Star	VOLVO FM (L)	11855908329
1 Star	VOLVO FL (H)	11678800018
1 Star	Renault D (H)	11455750189
1 Star	DAF LF Narrow (H)	11399828403
1 Star	DAF LF Wide (H)	10761706258
1 Star	VOLVO FH (L)	10511654059
1 Star	Renault D wide (H)	10402176610
1 Star	VOLVO FE (H)	10127570823
Zero Star	Renault 2.3 (L)	9238384792
Zero Star	VOLVO FMX(H)	9132682259
Zero Star	Mercedes 2.5 (L)	8845126225
Zero Star	Renault 2.3 (H)	8804207119
Zero Star	VOLVO FM (H)	8668453255
Zero Star	DAF CF N3 (L)	8273715327
Zero Star	SCANIA R (L)	8093612976
Zero Star	Mercedes Atego (H)	7944783753
Zero Star	Renault T (L)	7728093989
Zero Star	MAN TGS (L)	7388448541
Zero Star	SCANIA P (H)	7162295300
Zero Star	Renault 2.5 (L)	6738102584
Zero Star	VOLVO FH (H)	6608404299
Zero Star	DAF CF N3G (L)	6573001643
Zero Star	Renault 2.5 (H)	6455719206
Zero Star	DAF CF N3 (H)	5782332846
Zero Star	Renault T (H)	5773068474
Zero Star	Mercedes 2.3 (H)	5694463671
Zero Star	DAF CF N3G (H)	4921947683
Zero Star	Renault K (L)	4459080036

Zero Star	MAN TGS (H)	444000000
Zero Star	DAF XF (L)	4256445749
Zero Star	Mercedes 2.5 (H)	3936848288
Zero Star	Renault K (H)	3845336123
Zero Star	MAN TGX (L)	3519466704
Zero Star	SCANIA R (H)	3178067200
Zero Star	DAF XF (H)	3098598556
Zero Star	MAN TGX (H)	2477996700

Table 9. Table detailing the final volumetric results and the star boundaries

9.6.2 IMPACT OF THE LOWER DOOR WINDOW / REAR WINDOW ON THE DVS RATING

For a number of the vehicles assessed in the sample a lower door window (LDW) and / or window rear of the b-pillar (WRBP) was present. In order to explore the impact of these additional windows the volume increase for an example window set was calculated. Table 10 shows an example using the Volvo FM that has both windows available.

The specification of a lower door window increases the volumetric projection results between 4-9% based upon the mounting height of the vehicle. Critically this represents between 27-36% of the volume between star rating boundaries. The fitment of the window rear of the B-pillar has much less of an effect, an increase in volume up to 0.07% which is equivalent to 0.4 of a star rating boundary. This highlights that the LDW increases the visibility of the area of greatest risk by a good proportion, whereas the WRBP affords very little view of this critical area.

ADDITIONAL WINDOW CONTRIBUTION	Total Volume (mm ³)	Increase (mm ³)	% Increase	% of Star Rating
Volvo FM (High)	7.9552E+09			
Volvo FM (Low)	1.1320E+10			
VOLVO FM LDW (High)	8.6685E+09	7.1325E+08	8.97	36.49
VOLVO FM LDW (low)	1.1848E+10	5.2774E+08	4.66	27.00
VOLVO FM WRBP (High)	7.9552E+09	0.0000E+00	0.00	0.00
VOLVO FM WRBP (Low)	1.1328E+10	8.1123E+06	0.07	0.42

Table 10. Table showing the increase due to a lower door window (LDW) and window rear of the b-pillar (WRBP) in volume, as a percentage and as a percentage of a star rating (e.g. % of volumetric range between 1 and 2 star)

10 VALIDATION EXERCISE

As part of the DVS development process one manufacturer offered to recreate the DVS volumetric ratings for a specific vehicle in an effort to see how repeatable the LDS results were.

This involved the manufacturer applying the DVS analysis protocol using the same CAD data that they had supplied to the LDS team. The manufacturer wished to use their direct vision assessment tool, which is a plugin called CAVA for the CATIA CAD tool. This was seen as a positive approach to determining if the process of the DVS could be recreated in another CAD system with an analysis of any volumetric differences in the results.

This process highlighted the importance of the detailed description of key stages of the DVS protocol, including the alignment of the assessment volume. Initially there a difference in placement of the assessment zone of 0.446mm to the front of the cab between the LDS and manufacturer implementations which resulted in a 1% difference in the volumetric results.

This was corrected which led to a percentage difference between the results of the two CAD systems of 0.07%. A further analysis using the data to higher number of decimal places produced a result percentage difference of 0.01%. This difference was considered to be negligible by all parties involved.

This process improved the definition of the DVS protocol and demonstrated that the technique could be applied in two separate CAD systems with the same result. This process has subsequently been performed with three other manufacturers with the same result.

11 DISCUSSION

The methodology and results in this report present an overview of what was a highly iterative process as presented in detail in the Appendices. The method of assessment and in particular the quantification of the volumetric results and ultimately the use of these data to produce the star rating boundaries was produced in parallel with data collection. The collection of data as summarised in Table 8 was beholden on the ability of manufacturers to supply the data in CAD form or provide access to vehicles. In some cases this needed considerable internal negotiation to obtain the clearance to make this sensitive data available to support the project. As such the sample was increasing as the methodology evolved.

In addition, as can be seen from the volumetric results and more clearly, the VRU simulation distances the performance of the vehicle fleet is extremely poor. The vast majority of the fleet cannot see a small adult via direct vision within an average of 2m of the cab. Because of this, and its potential impact on the industry many alternative solutions were considered. Whilst it is not the purpose of this report to detail every option considered in full, some of the considerations evaluated are summarised below:

It was acknowledged that the trimmed assessment zone of 4.5m to the passenger side could still be considered to be too large given the focus on direct vision of VRUs. When considering the scenarios of accidents to the passenger side it is likely that the pedestrian or cyclist would need to be seen much closer to the vehicle. However, reducing the assessment zone on the passenger side to less than 4.5m would have left most vehicles in the sample (and the fleet) with almost no projected volume and thus differentiation would have been much more difficult.

The 5th %ile Italian female lower threshold was used in an attempt to provide a lower limit based on population data. The 5th %ile female provides context in terms of Europe by being representative of more than 99% of the adult population. The results show that this threshold proved to be extremely challenging for the vehicles in the sample with many performing very poorly. As discussed earlier alternatives were considered. A 50th %ile UK male was also evaluated. This produced improved but still largely poor results in terms of the distance away that a VRU could be seen. Using a larger VRU simulation also eroded the message regarding safety. If the assessment is based upon an 'average' sized threshold value all it really does is suggest that it is not important to be able to see half of the population. In reality defining the head and shoulders of a small adult still potentially excludes the vision identification of wheel chair users, children and scooter users. This has been considered through review of the accident data which highlights that these

VRUs are rarely involved in accidents with HGVs. A compromise has been derived which allows the vehicle design to be differentiated.

The use of head and shoulders for visibility of the VRU simulations was a challenging part of the project. In previous work the LDS team had deliberately avoided the complexity of determining how much of a VRU was enough to enable recognition by a driver by positioning the VRU simulations at a point where they were just not visible. This is particularly challenging in the more complex areas of the field of view, such as around the mirrors when 'most' of a head and shoulder could be visible but not all. There is no data to be able to determine how much of a VRU is enough to enable recognition as the research has not been done and thus a consistent approach was taken in the placement of VRUs in these situations. However, it should be noted that in adverse weather conditions, poor lighting, dark clothing, situations of high driver workload through busy traffic, job pressures etc. that it could still be possible that a driver may not recognise the head and shoulders of a VRU in proximity to the vehicle.

The VRU simulations were introduced to provide a quantification of the volumetric results. In addition, the VRU simulations provide context and accessibility of the volumetric results. In isolation the volumetric results are rather arbitrary and have little meaning in an absolute sense. However, they a very high resolution evaluation of the direct vision performance of a vehicle. In contrast the VRU results have high impact, they clearly demonstrate the capability of a vehicle. However, the VRU results are relatively low resolution, with arguably only 13 data points, compared to the many thousands of data points that the complexity of the projection paths produced demonstrate. As such they are an approximation of the high resolution volumetric data and thus are only used to augment the volumetric assessment, not replace it.

A number of the vehicles assessed can be fitted with lower door windows that have been added to vehicle from the start of the vehicle design process. Some vehicles were therefore evaluated with and without the door window. The lower door window can therefore make a direct contribution to improving the volumetric result as described in Section 9.6.2. However, the lower door windows were not considered in the VRU simulations. As the VRU simulations required head and shoulders to be seen the lower door windows in the vehicles assessed played no part in affording this view. In some instances the lower door window provided a view of the legs or torso of the VRU however this was considered to be too difficult to evaluate in terms of the benefit to the driver in terms of recognition of a VRU. The result is that lower door windows are considered to be a positive offering for direct vision and thus they are included in the volumetric results and will contribute to improving a vehicle's performance and potentially its star rating but they were not used for determining the star boundaries.

Once the threshold vehicle and thus threshold volume was determined in the production of the star rating boundaries the remaining data were equally subdivided. In the case of option 3, this subdivided the data between the threshold and the best performing vehicle's volume into five. The division could have been into four equal sections, to represent the performance between 1-2, 2-3, 3-4 and 4-5 star. However, five divisions were considered to be more appropriate to reduce five star performance being reliant on a single vehicle; to ensure there was an opportunity for there to be more than one vehicle in the fleet that could be rated as five star, and encourage manufacturers to develop improved future vehicles aspiring to a five star rating.

The use of an equal subdivision of the volumetric results to define the star rating boundaries beyond 1 star (in the case of option 3) was a pragmatic decision to aid understanding and in acknowledgement of the lack of data to inform anything more strategic. Ideally, all of the thresholds would have been based on real world performance via the VRU simulations. However, as already discussed the data to suggest exactly what needs to be seen, and where in proximity to the vehicle, is not understood. As such, performance values in a

manner that would allow differentiation to five levels cannot be reliably and meaningfully determined. In absence of these data, a simple even subdivision of the data was considered to be appropriate.

The eye point definition detailed in Section 9.3.1 changed during the development of the DVS. The initial proposal used an offset from the R-point (SgRP) of the seat, based upon UN ECE Regulation 46. It was the assumption that using standardised references and procedures would fit with industry standard practices. However, on review of the R-point supplied by the manufacturers, it was noted that the definition of the R-point varied significantly, contrary to how the R-point is defined in the automotive industry. This variability led to significant variability across manufacturers and thus the volumetric assessments were not just a function of cab design but also the interpretation of the R-point which was deemed unacceptable. Thus, the final proposed eye point definition was developed to remove this inconsistency and agreed by the stakeholder group. Due to the timing of this change in the development process of the DVS, the results presented in the Appendices utilise the original (R-point based) eye point. Results in the main body of the report utilise the new eye point.

The definition of vehicle height was a topic of considerable discussion by the stakeholder group. The vehicle height over and above the specification of the vehicle is subject to variability based upon load. Load is a function of the vehicle structure and any cargo it is carrying. Thus, the height for a single configuration was agreed to be defined by a proxy average to take into account the effects of loading, and the frame and cab should be horizontal.

The proxy average (Z_p) is defined as the mean value between the technical design maximum, by axle, (Z_{dm}) and the unladen chassis cab (Z_u) as shown in Figure 45. Thus, for a given nominal cab height h , the proxy average is given by the following equation:

$$Z_{ph} = (Z_{uh} - Z_{dm}h) / 2$$

Each nominal height shall be determined by the manufacturer's specifications for axle and suspension.

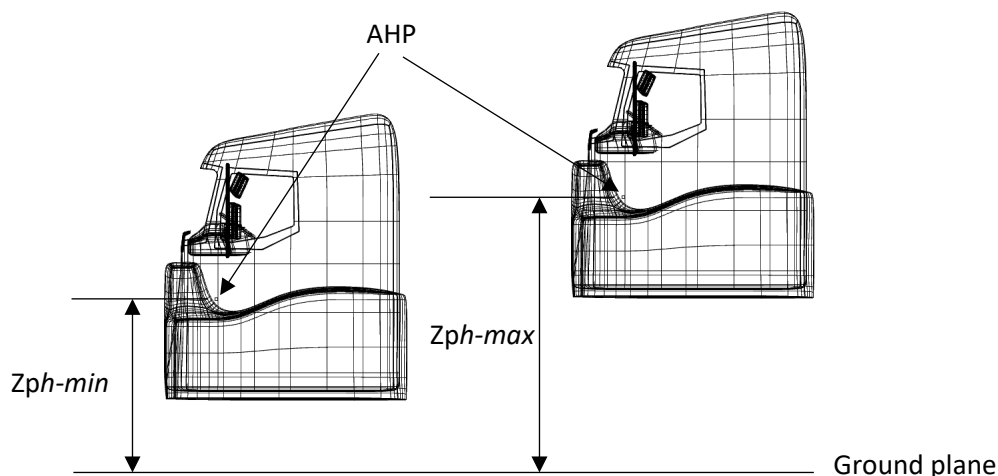

Figure 44. Assessment height range between the proxy average maximum vehicle height (Z_{ph-max}) and the proxy average minimum vehicle height (Z_{ph-min})

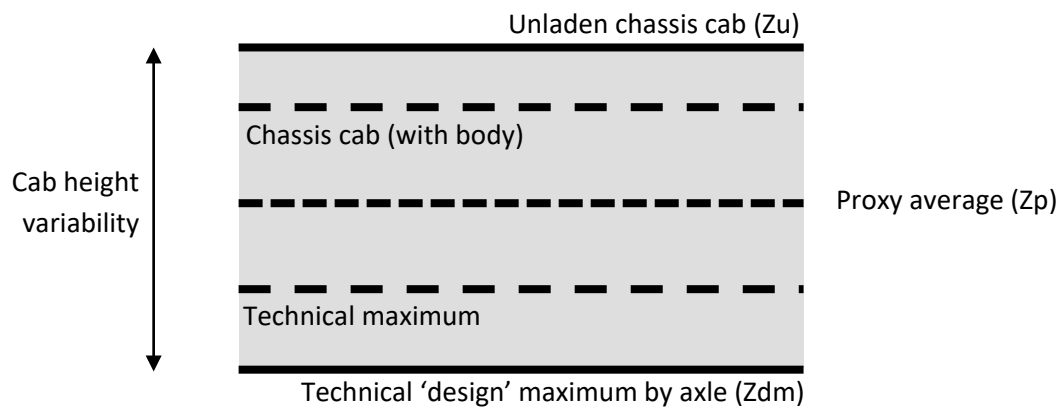

Figure 45. Proxy average cab height definition

The complexity of the assessment methodology and its repeatability on different CAD systems was a key factor. As has already been discussed some considerations were ultimately discounted due to complexity. The resulting method is a simplification of the field of view afforded to a driver in the real world. However, a proliferation of eye points in terms of both the head direction and (am)binocular vision increases the complexity of the evaluation exponentially. In some cases the evaluation becomes nearly impossible in any sensible timeframe. For the example of ambinoocular projection described in Appendix B, additional vehicles beyond the two presented were attempted but could not be completed as the projections would have needed to have been recreated manually to produce the combined ambinoocular projection. This processing would have taken days of effort to produce only one result. This complexity was also highlighted by the stakeholders who advocated simplicity wherever possible.

The project has resulted in two main outcomes, a rating methodology for the evaluation of the direct vision performance of an HGV together with the definition of a star rating system that together form the DVS. The evaluation methodology of a vehicle has been detailed in a DVS protocol that will allow anyone to evaluate a vehicle with the appropriate data and plot the results against the DVS star ratings.

The detail of the protocol has evolved through the consultation phase performed in the Autumn of 2017 when manufacturers applied the protocol in a range of CAD systems.

As described earlier some elements of vehicle geometry such as the windscreen wipers result in mathematically determined 'apertures' that could be projected to contribute to the volumetric result. However, some are so small as to not contribute to direct vision performance. This could be addressed by specifying a limit to the area that can be counted but there is no data to inform such a limit. The danger is that designs could be envisaged in which volumetric performance is augmented through mesh like surfaces. The collective small apertures may result in substantial volumetric results but afford poor direct vision. This needs to be avoided and there has to be a baseline of a spirit of the DVS protocol in addition to letter of the DVS protocol.

At the start of the project the use of accident data to identify the areas of greatest risk and to then apply weightings to the DVS volumetric results to reflect the importance of direct vision to certain locations around the cab was seen as a valuable approach. The project has highlighted that this approach did not improve the applicability of the DVS scores and so the data has not been weighted.

The DVS project and the final DVS system definition is the result of a concerted effort by TfL and LDS staff in the involvement of all key stakeholders in the design process. The process has included visits to the design teams for VOLVO, Daimler, SCANIA, and DAF. The open and constructive approach taken by the vehicle manufacturers has been invaluable to the project teams. This has resulted in a standard which has real potential to improve the safety of the urban environment in London and further afield. In addition the standard has the potential to influence the future design of truck cabs with regard to the detailed consideration of direct vision.

The TfL and LDS teams would like to thank the following stakeholders for their valuable contributions to the project.

DAF

Johan Broeders

Philip Moon

Piet Kuylaars

Roger Bosmans

Mercedes

Ross Paterson

Rupert Barnard

Martin Tebbe

Stefan Huegin

Bob Gowans

Volvo

Claes Avedal

John Comer

Hanna Degerman

Michael Dahl

Hannah Burgess

Mari Eriksson

SCANIA

Phillip Rootham

Jorge Soria Galvarro

Hanna Staf

MAN

Les Bishop

Ashlea Awbery

Renault

Andrew Scott

Mike Stringer

IVECO

Stuart Badcock

Martin Flach

12 APPENDICES

A. CANDIDATE ASSESSMENT VOLUMES

The sections below describe the iterative process and the options considered in defining the assessment volume for the volumetric evaluation.

THE VERTICAL SPECIFICATION OF THE ASSESSMENT VOLUME

The Draft TRL DVS proposed a vertical arrangement of the assessment volume that consisted of two zones that extended from a point 0.93m from the floor to 1.41m from the floor and from 1.41m from the floor to 1.87m from the floor as shown in Figure 46.

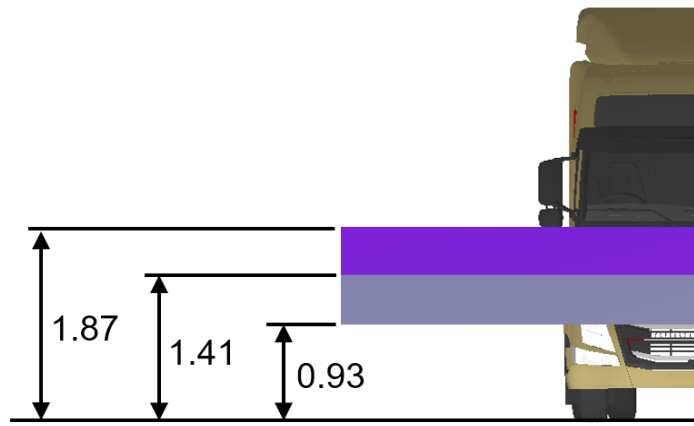

Figure 46. Vertical specification of the assessment zone as proposed in the Draft TRL DVS

Whilst this approach would cover the majority of vulnerable road users it was considered to be limiting in that the assessment zone did not extend to the floor. The lower zone was considered important to provide assessment of vision performance nearer to the ground where VRUs such as children may be present. Furthermore, an increased assessment zone in the most challenging area for HGVs and would both foster and provide a means to evaluate new designs that maximised direct vision. To account for these issues two alternate zones were proposed.

The first option was a single volume that extended from 1.602m to the ground as detailed in Section 9.4.1 and shown in Figure 47.

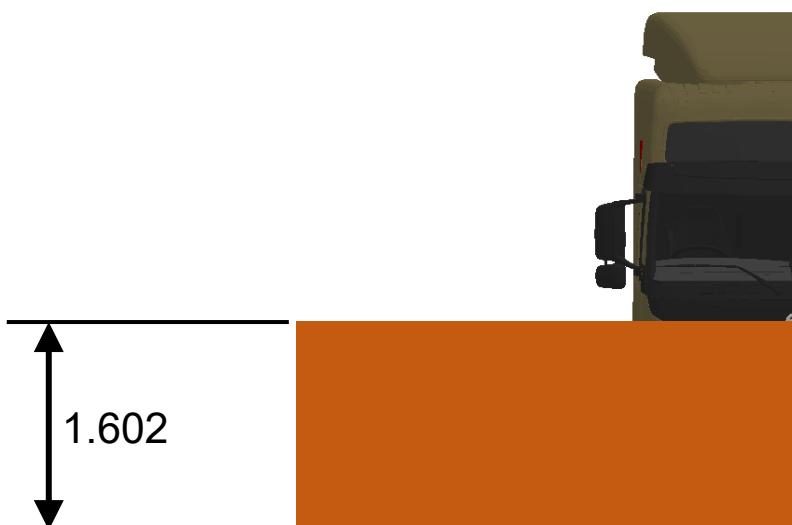

Figure 47. First option for the vertical specification of the assessment zone

The second option divided option 1 into a series of layers. The layers were introduced to allow weightings to be subsequently explored in the assessments. For example, the layers would allow more emphasis to be placed on being able to see lower and therefore rewarding vehicles with better direct vision performance. The layers represented a differentiation in equal segments between the shoulder height of the smallest population in Europe (Italian females) through to the same upper limit represented by the tallest European population (Dutch males). Figure 48 shows the zones in this option with a large zone extending from the floor to 1.177m from the floor and then five equal zones between 1.177m and 1.602m. The figure also shows how this is representative of other %iles and populations from across Europe.

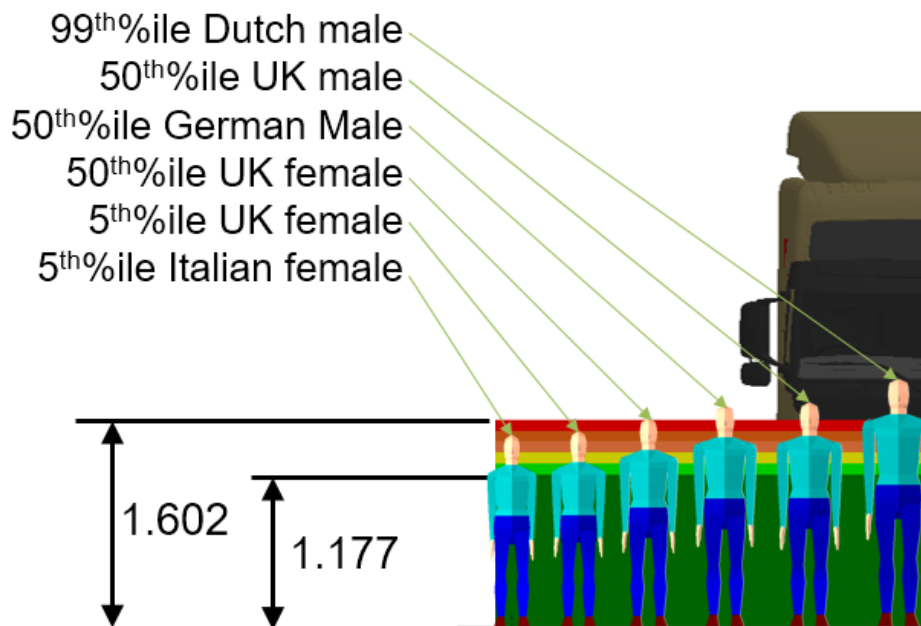

Figure 48. Second option for the vertical specification of the assessment zone

THE HORIZONTAL SPECIFICATION OF THE ASSESSMENT VOLUME

The Draft TRL DVS proposed a horizontal arrangement of the assessment volume that consisted of an area extending across the passenger side and front of the cab as shown in Figure 49. The specification of this zone included a number of features:

- The zones are offset from the sides of the cab by 0.3m representing the hip breadth of a large US female
- The zone extends to the nearside 3.5m to cover a standard road lane width
- The zone extends to the front by 4.7m based upon the evaluations carried out by TRL on the assessment vehicles

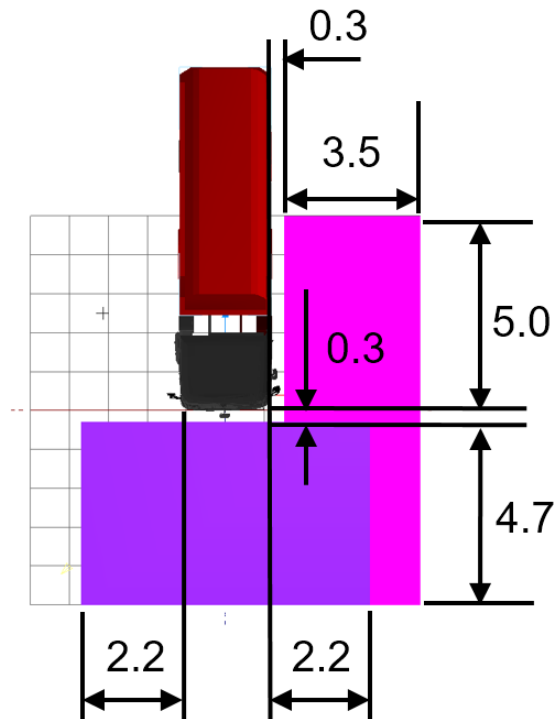

Figure 49. Horizontal specification of the assessment zone as proposed in the Draft TRL DVS

This approach was considered to be limited for a number of reasons as outlined in Section 5.2 however the primary issues were the lack of driver side zone, the large assumptions made about the movement of VRUs about the vehicle, and the offset of the zone from the side of the vehicle using hip breadth as a measure for where the visible part of a VRU would be positioned. To account for these issues two alternate zones were proposed.

The first candidate was a large 20m by 20m zone centred on the driver's eye point laterally such that 10m extended to the left and right of this point. The zone extends 1m to the rear of the eye point and there is no gap between the outer surfaces of the cab and the zone to both the front and sides as shown in Figure 50. The premise for this candidate was to ensure that all vehicles no matter their direct vision performance would produce projections that intersected the assessment volume. The large size would also account for direct vision performance where blind spots are known to exist at considerable distances from the cab due to issues such as A-pillar obscuration. In addition, the candidate accounted for front, driver and passenger sides, and allowed all of the possible area around the cab to be evaluated with no offset.

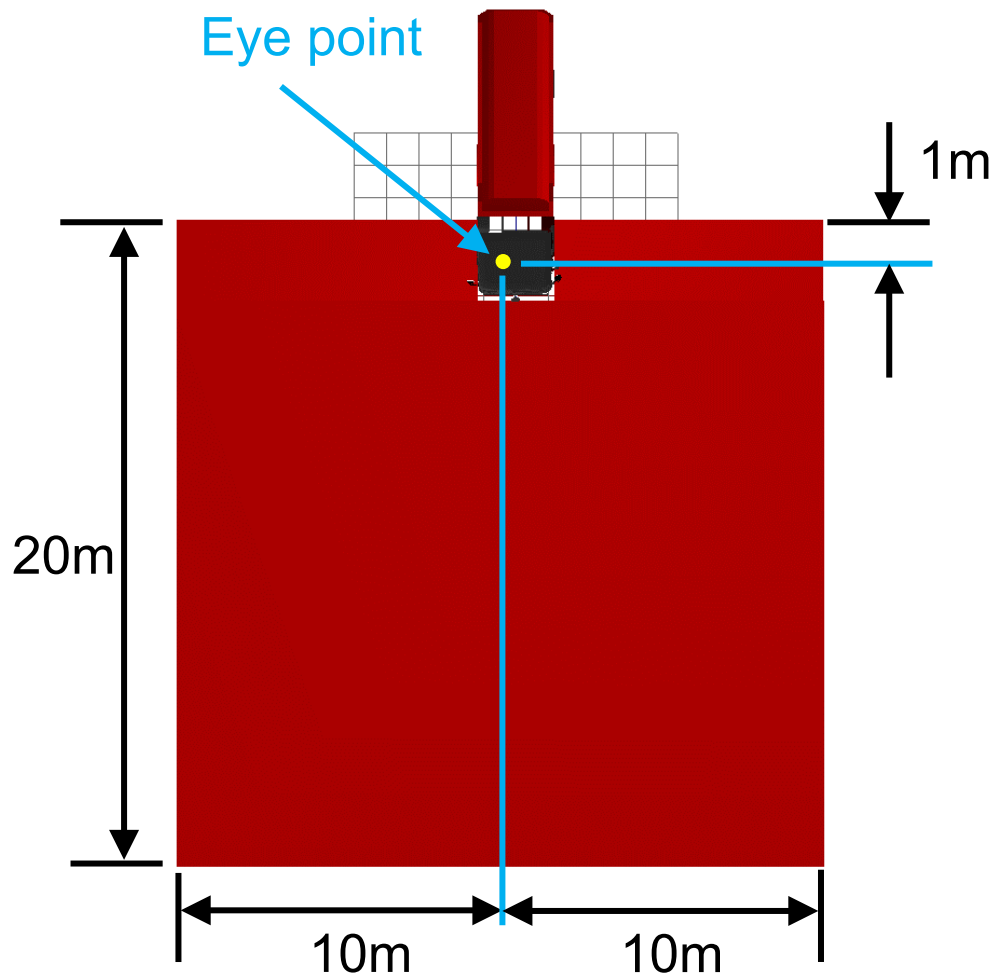

Figure 50. Candidate 1 for the horizontal specification of the assessment zone

The second candidate was effectively a trimmed version of candidate 1 as detailed in Section 9.4.2 and shown in Figure 51. See section 9.4.2 for rationale for the definition of the size and orientation of Candidate 2.

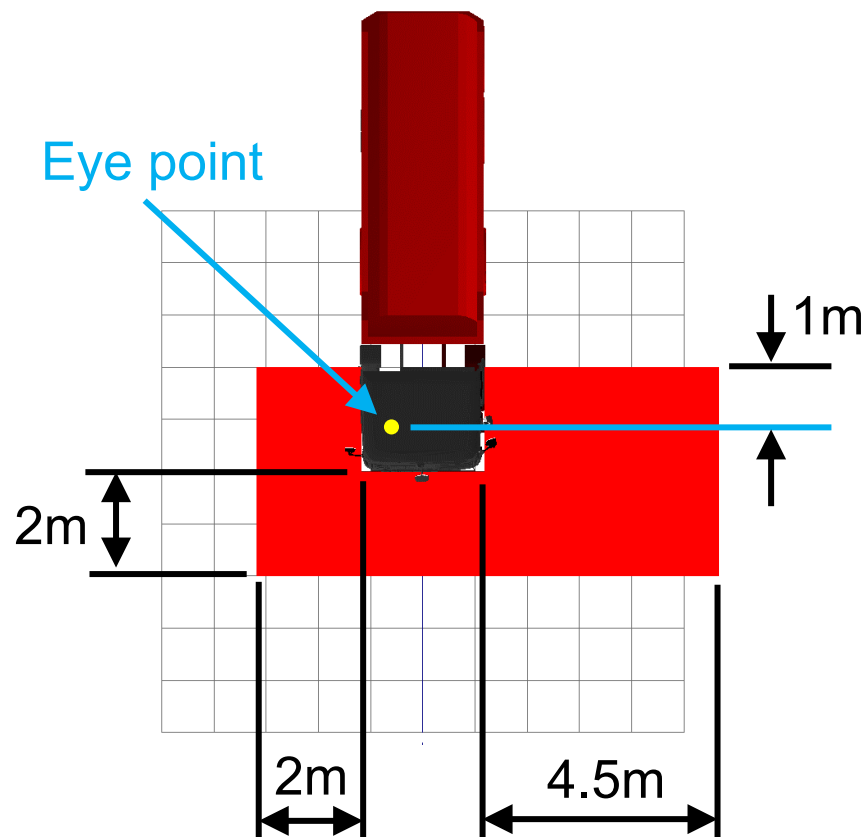

Figure 51. Candidate 2 for the horizontal specification of the assessment zone

B. RESULTS OF THE VOLUMETRIC ASSESSMENTS EXPLORED

The Sections below describe the range of assessments explored and the resulting volumetric score generated in defining the final version of the DVS.

It should be noted that the results presented here represent the thinking and process being applied at that point in the development of the DVS. Thus the vehicle sample and the volumetric results for any given vehicle may differ from the final results shown in Section 9.6.1.

VOLUMETRIC RESULTS FOR ALL VEHICLES USING CANDIDATE 1 (UNTRIMMED) ASSESSMENT ZONE VOLUME

Figure 36 shows the results for the candidate 1 assessment volume (see Figure 52) with single vertical section (see Figure 34).

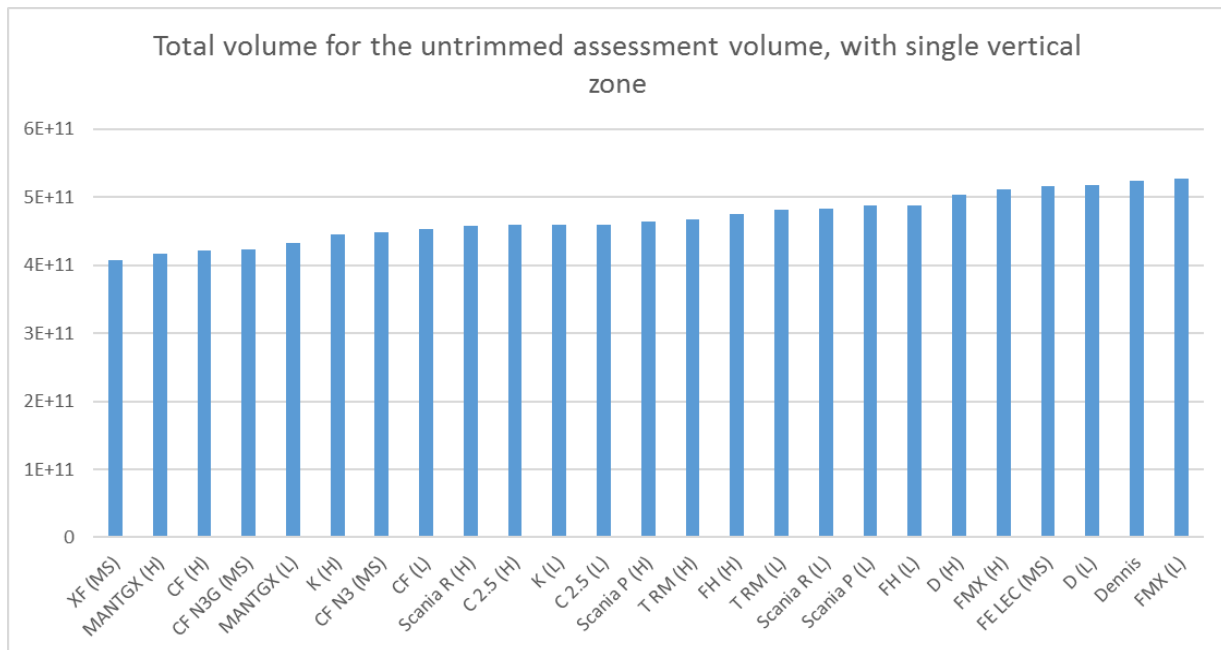

Figure 52. Results for the candidate 1 (untrimmed) assessment zone volumes with single vertical section

At this stage in the evaluations it was clear that a method was required to place the volumetric results into context relevant to the direct vision of VRUs in proximity to the cab. In order to provide this a VRU simulation similar to that applied in previous work by the LDS team was used¹⁴.

QUANTIFYING VOLUMETRIC RESULTS AGAINST REAL WORLD PERFORMANCE

Continuing the methodology of the need to be able to see the head and shoulders of a VRU introduced in Section 9.4.1 a process to quantify the volumetric results against real world performance was developed. This quantification took the form of a number of VRU simulations (human models of a given stature) placed around the vehicle and moved laterally to a point at which their head and shoulders is visible to the driver as shown in Figure 18.

¹⁴ See Summerskill et al., (2015). Understanding Direct and Indirect Driver Vision in Heavy Goods Vehicles, Final Report. Section 3.4 concerning VRU visibility analysis.

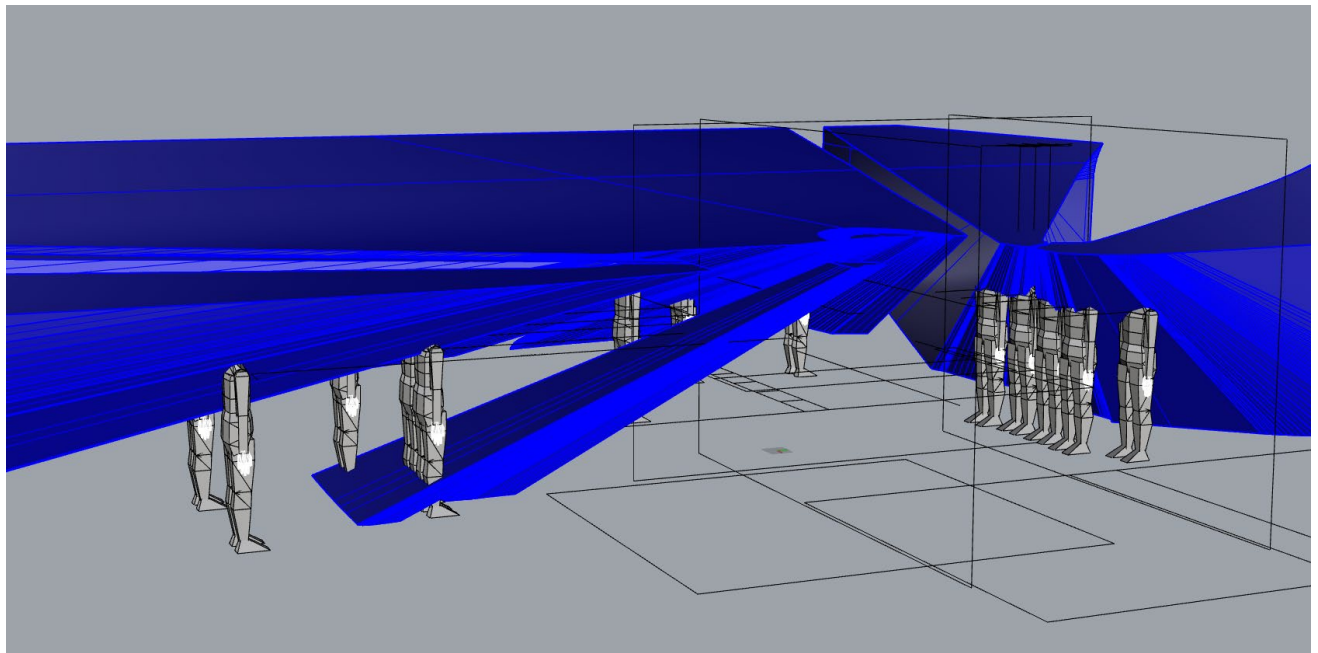

Figure 53. Intersection of the VRU simulations with the projection volumes. VRUs positioned such that the head and shoulders intersect with the projections and thus head and shoulders are visible in these locations.

A number of variants of this method were evaluated including nine VRU simulations (three to the front, and three to both the left and right of the cab) and thirteen VRU simulations (three to the front and five to both the left and right of the cab), VRU simulations with a 5th %ile Italian female stature (1500mm high) and VRU simulations with 50th %ile UK male stature (1755mm high).

After an evaluation of the various options the configuration detailed in Section 9.1.3 and shown in Figure 19 was adopted using 5th %ile Italian female VRUs to ensure that performance is evaluated and rated against a threshold that represents over 99% of the European population.

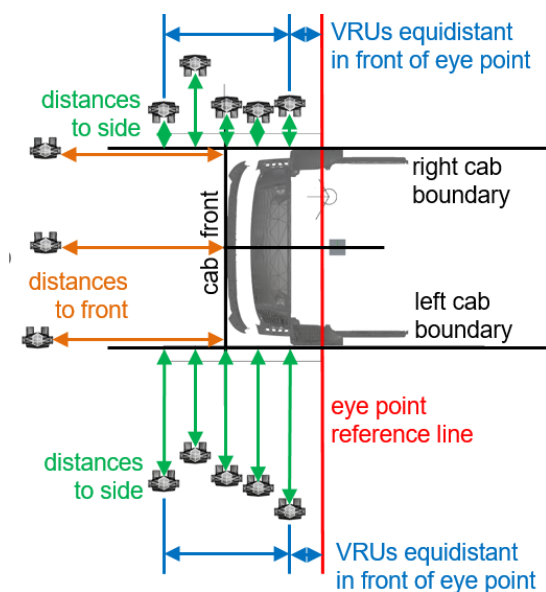

Figure 54. VRU simulations positioned around the vehicle to provide quantification of the volumetric analysis

CORRELATION RESULTS OF CANDIDATE 1 (UNTRIMMED) ASSESSMENT ZONE VOLUMES AGAINST VRU DISTANCE

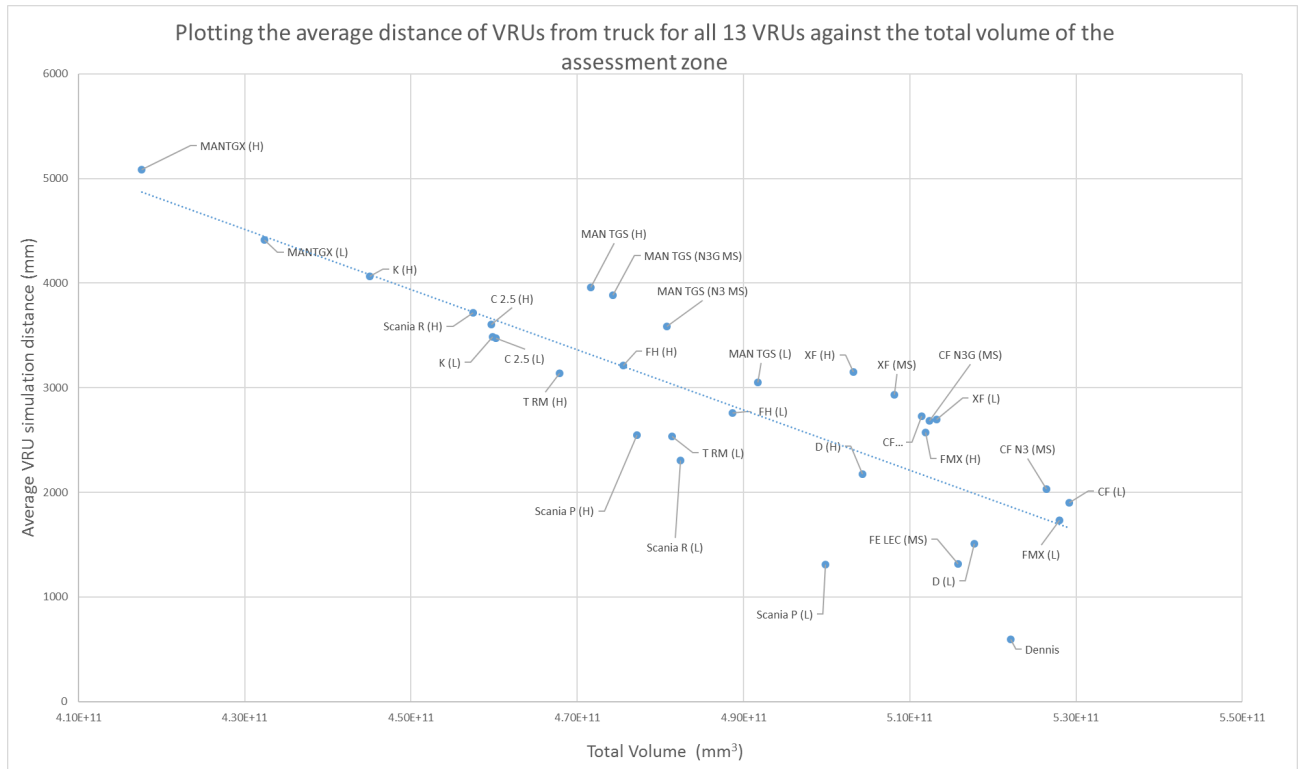

Figure 55. Graph showing the volumetric results from candidate 1 assessment zone (untruncated volumes) with single vertical section correlated with the average distance of the 13 VRU simulations

As shown in Figure 55 and documented in Section 9.5.2 the use of the VRU simulations provided a quantification of the volumetric results. This quantification addressed not only the issue of accessibility of the results but also provided a means to later determine thresholds for star ratings.

One of the observations of the results was that whilst the correlation of volume to VRU distances was successful for quantifying the volumetric results, there were some characteristics of the data that were not ideal. Figure 56 shows the same graph as shown in Figure 55 with two pairs of vehicles highlighted. In both of these cases two vehicles can be observed to have similar volumetric performance and yet different VRU performance. It was acknowledged that this is due to the resolution of the two assessment methods. The volumetric assessment performance is considered to be a high-resolution evaluation taking account of all of the field of view afforded the driver. However, the VRU assessment could be argued to be a low-resolution evaluation having effectively only 13 data points. The phenomenon observed in Figure 56 is therefore not surprising but does pose some potential challenges when ultimately determining and justifying star rating boundaries. In order to attempt to improve the data to differentiate between vehicles a range of evaluations were performed exploring the options outlined in previous sections with the candidate 2 assessment zone and volume weighting.

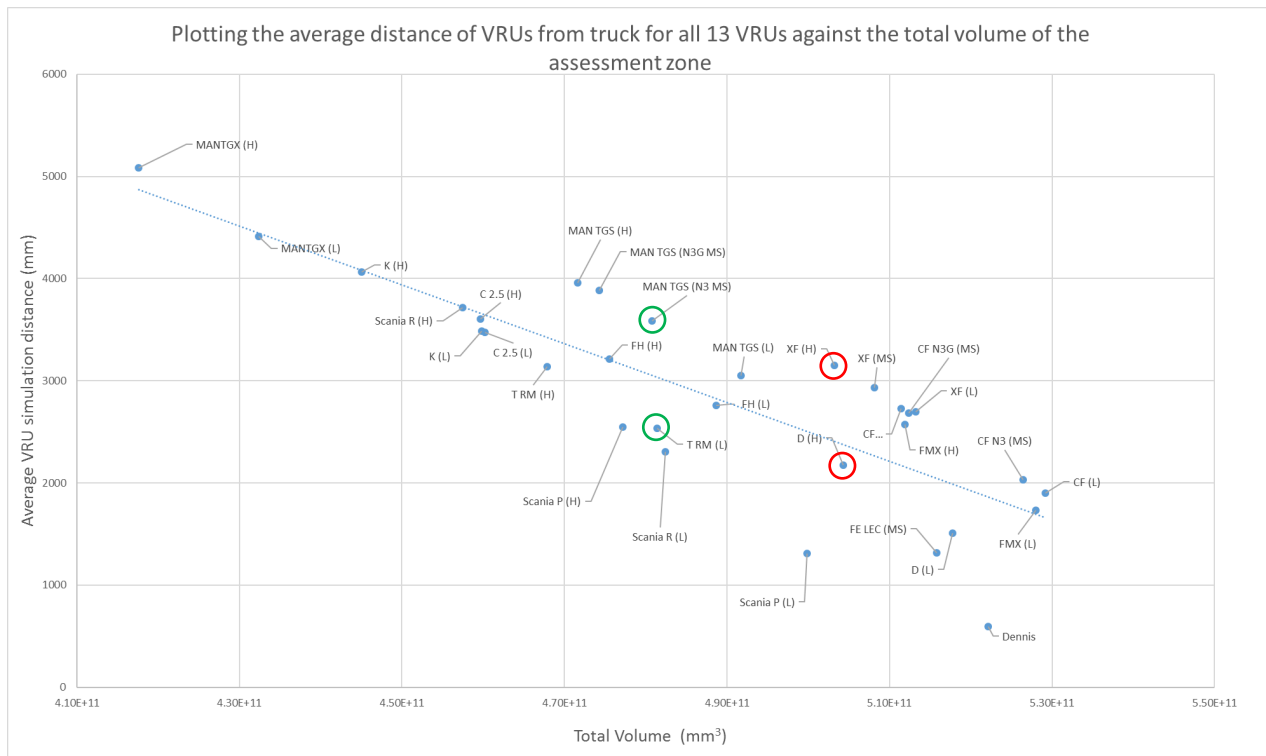

Figure 56. Volumetric results from candidate 1 assessment zone (untrimmed volumes) with single vertical section correlated with the average distance of the 13 VRU simulations. Highlighted vehicles have similar volumetric performance but different VRU performance.

VOLUMETRIC RESULTS FOR ALL VEHICLES USING CANDIDATE 2 (TRIMMED) ASSESSMENT ZONE VOLUMES

Figure 57 shows the results for the candidate 2 assessment zone volumes (see Figure 51) with single vertical section (see Figure 47).

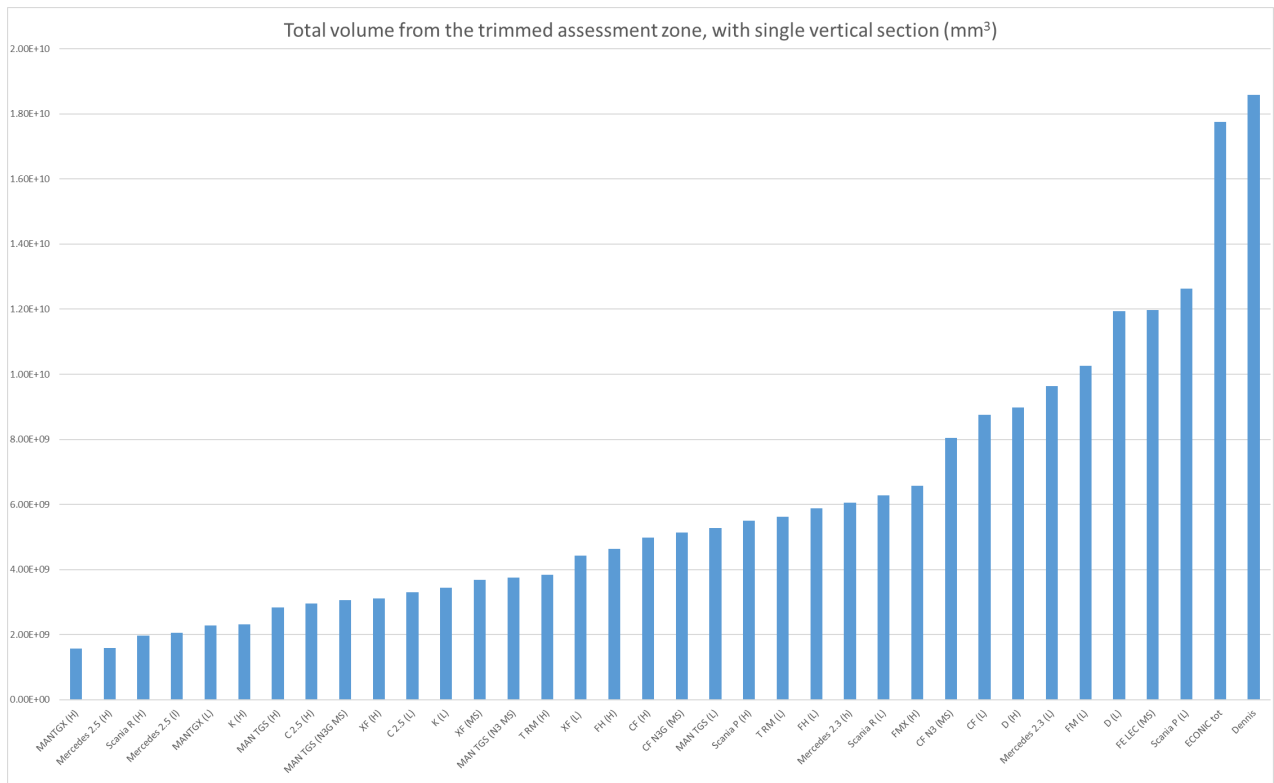

Figure 57. Results for candidate 2 assessment zone (trimmed) volumes with single vertical section

What can be seen from the results of candidate 2 assessment zone on the volumetric evaluation is much greater differentiation between vehicles than that demonstrated by candidate 1 assessment zone shown in Figure 52.

CORRELATION RESULTS OF CANDIDATE 2 (TRIMMED) ASSESSMENT ZONE VOLUMES AGAINST VRU DISTANCE

Figure 58 shows the correlation of candidate 2 assessment zone volumetric results to the average of the 13 VRU distances. The issues observed in Figure 56 were largely removed by trimming candidate 1. The correlation augments the volume graph shown in Figure 57 by highlighting the performance of the best vehicles (low entry cabs) which are significantly distanced from the majority of the fleet.

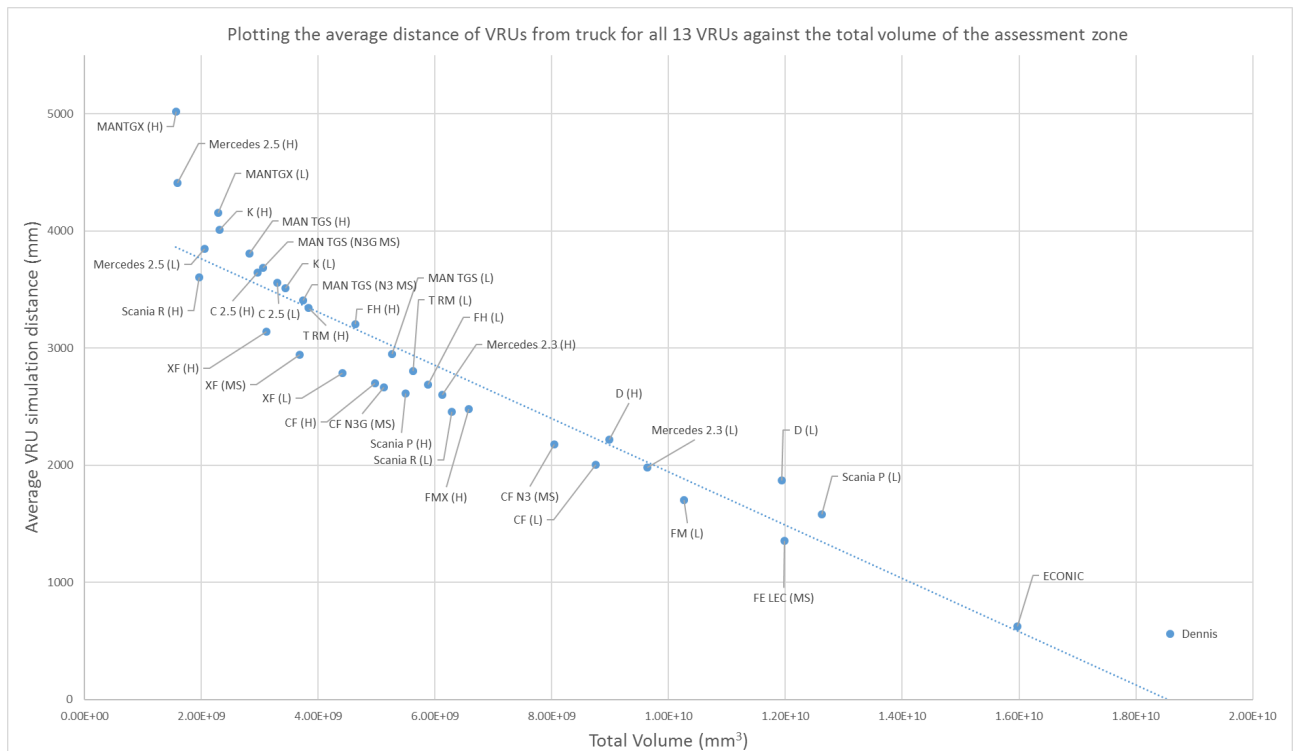

Figure 58. Graph showing the volumetric results from the candidate 2 assessment zone (trimmed) with single vertical section correlated with the average distance of the 13 VRU simulations

EXPLORING WEIGHTING OF THE ASSESSMENT ZONES

In an attempt to further refine the spread of the volumetric results a range of weighting options were explored. These included:

Weighting the multiple vertical layers shown in Figure 48. The weightings applied halved the importance of each layer from the bottom to the top.

Colour name	Weighting	Colour shown
Red	1/64	
Orange	1/32	
Gold	1/16	
Yellow	1/8	
Green	1/4	
Dark Green	1/2	

Weighting by direction, taking into account the areas of greatest risk shown in Figure 6

The result of the vertical weighting applied to the candidate 2 assessment zone volumes is shown in Figure 59. The weighting further exaggerated the differences between the best and worst performing vehicles but also bunched the majority of vehicles to the left of the graph. This reduced the ability to differentiate between vehicles and so was ultimately rejected.

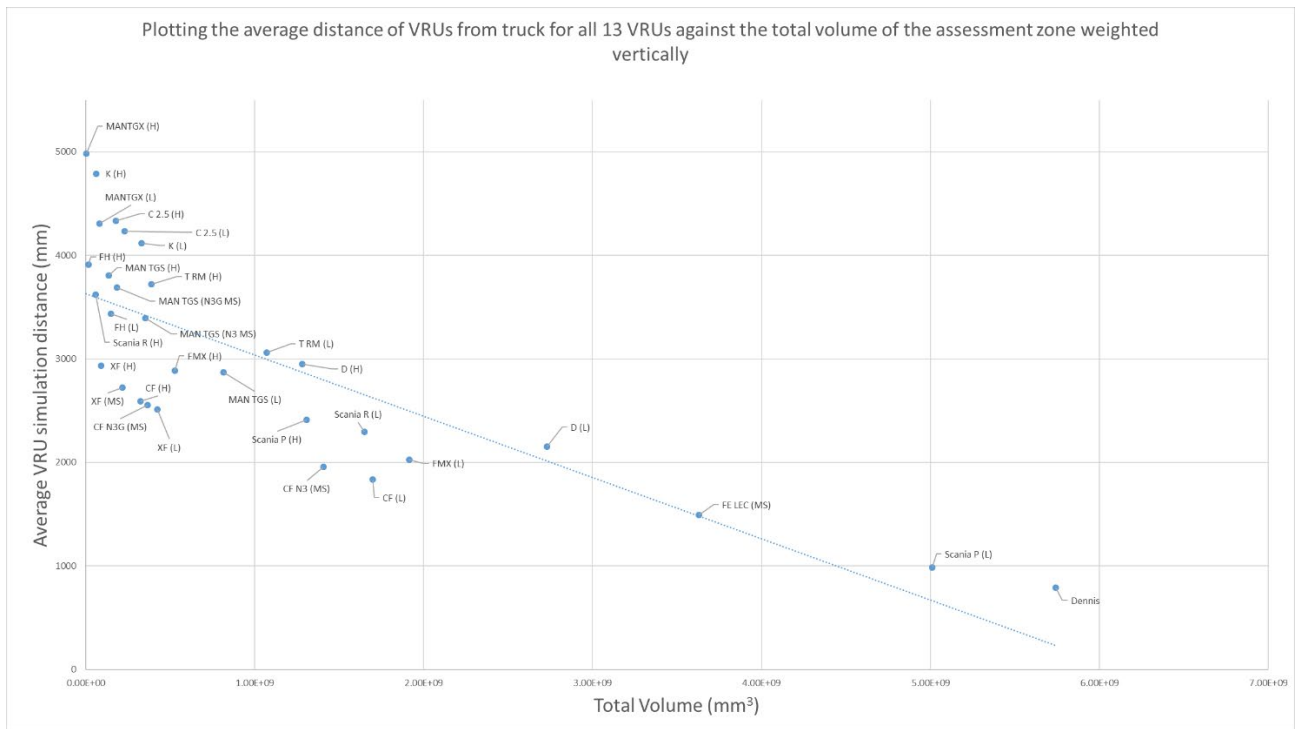

Figure 59. Graph showing the volumetric results from candidate 2 assessment zone (trimmed) with multiple vertical sections weighted of decreasing importance from bottom to top, correlated with the average distance of the 13 VRU simulations

The result of the weighting by direction based upon the accident data and the area of greatest risk applied to the candidate 2 assessment zone volumes is shown in Figure 60. As seen with the vertical weight, the weighting by direction also led to the majority of vehicles to be bunched to the left of the graph, though to a lesser extent. Again, this reduced the ability to differentiate between vehicles and so was rejected.

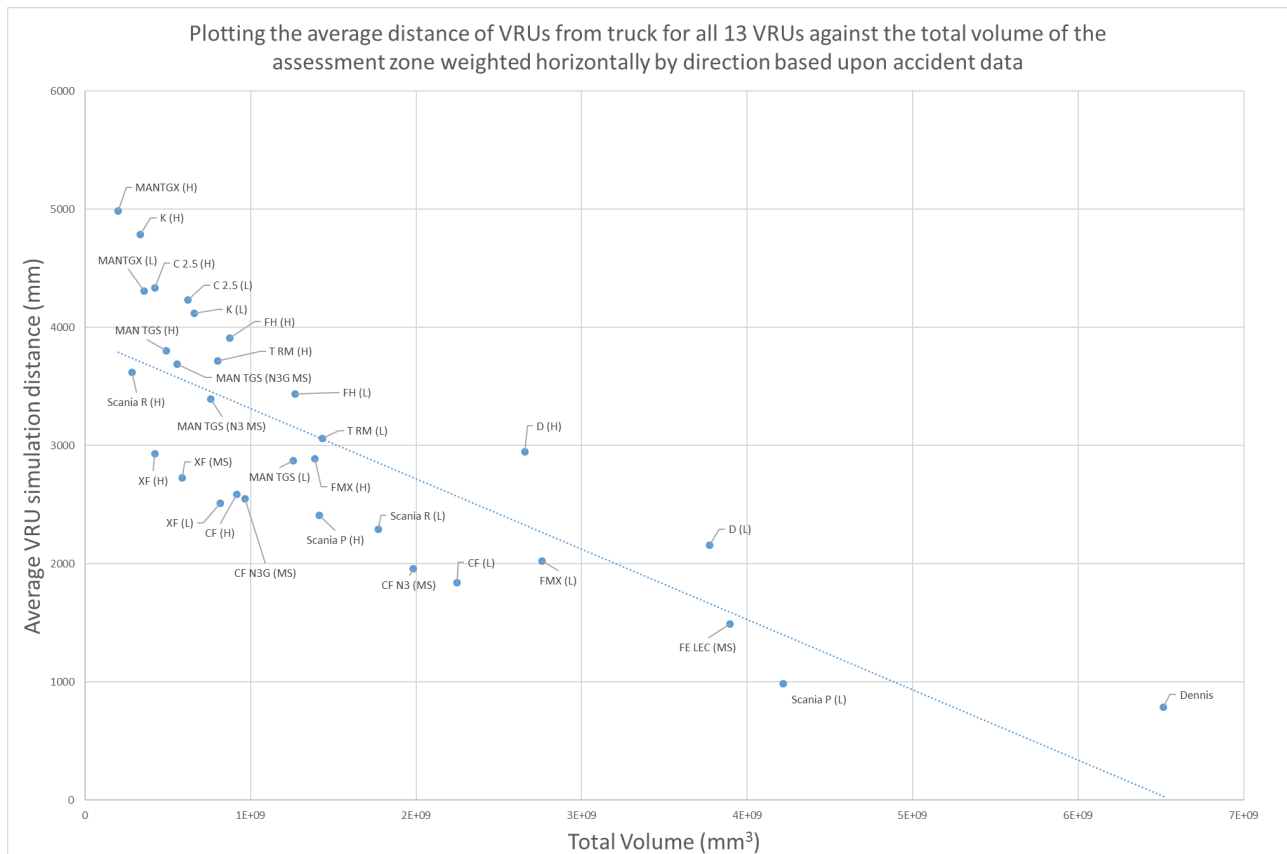

Figure 60. Graph showing the volumetric results from the candidate 2 assessment zone (trimmed) with single vertical section weighted by direction (front, left and right) based upon accident data, correlated with the average distance of the 13 VRU simulations

EXPLORING AMBINOCULAR PROJECTIONS

As discussed in Section 9.3.1 the projections used in the evaluations could be generated using a single or pair of eye points. Whilst it was believed that a monocular eye point was optimal, the impact of using an ambinocular projection was explored. Three vehicles were assessed using a pair of eye points as specified in SAEJ1050. The projection volumes using the two methods on two sample vehicles: DAF XF (MS) and the Renault T (H) are shown in Table 11 below. The vehicles selected for assessment were selected due to their similarity in their volumetric results and proximity in the correlation graph as shown in Figure 61 (left).

	Total Volume (mm ³)		Difference (mm)	Difference (%)
	Monocular	Ambinocular		
DAF XF (MS)	3.69E+09	4.30E+09	6.13E+08	16.61
Renault T (H)	3.84E+09	4.41E+09	5.74E+08	14.97

Table 11. Volumetric results comparing monocular projection to ambinocular projection

The results in Table 11 show that for the vehicles assessed there is a 15.0 – 16.6% increase when moving to an ambinocular assessment. Whilst this increase can be considered substantial what is also clear is that both results increased, and they both increased by a similar amount. Critically the ambinocular results do not

change the order of the results as shown in Figure 61 (right) and when the increase is compared to the total candidate 2 assessment zone the increase is only 0.01 %.

This lack of change in the order of the results combined and the small increase in volume when compared to the assessment volume, the considerable additional work in generating ambinocular projections was not considered to be a worthwhile addition to the method for evaluating the performance of an HGV. This decision was reviewed with the expert panel with the majority of stakeholders in agreement. Some stakeholders stated that they did have processes which allowed ambinocular projections in an affective manner. The shared view by the majority of stakeholders was that the benefits did not outweigh the costs associated with the extra time required to produce ambinocular DVS ratings.

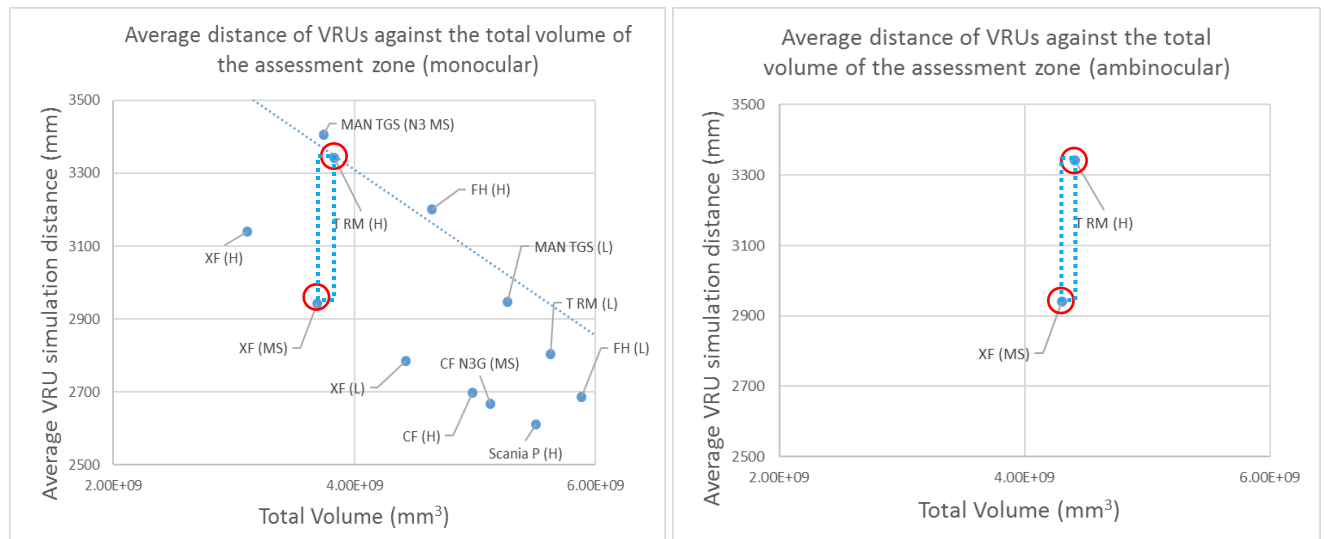

Figure 61. Sample of the full correlation of the volumetric results from the candidate 2 assessment zone (trimmed) with single vertical section with the average distance of the 13 VRU simulations – highlighting the vehicles evaluated for ambinocular projections. Left image shows the monocular volumes. Right image shows the ambinocular volumes.

C. DEVELOPMENT OF THE STAR RATING SCHEME

With an assessment volume and VRU approach defined the next phase of the project was to explore how the star rating boundaries of the DVS would be set. Four candidates were considered split into two options for an ‘Absolute approach’ and a ‘Relative approach’. These were defined as:

The Absolute approach: In which the star rating boundaries would be defined based upon a minimum performance which was inclusive of the whole European population and was considered to represent a **desired** level of direct vision from a risk perspective

The Relative approach: In which the star rating boundaries would be defined based upon the **current performance of existing vehicles** in the fleet

The relative and absolute approaches were defined to allow a comparison of the outputs in terms of the safety benefit, and the cost to the haulage industry, manufacturers and other stakeholders that would be determined in an impact assessment study performed separately. In addition, it was agreed that for each approach there would be a version of the star rating based system based upon the VRU distance technique to define the minimum requirement, and also a version which was based upon the median volumetric score. That is, one version based upon VRU distance, and one version based upon the volumetric data alone.

The four different approaches were there defined as the following;

Absolute approach

Option 1: Testing the distance away that an average sized UK male (50thile = 1755mm tall) could be seen to the front, offside and passenger side of the truck

Option 2: Testing the distance away that a small Italian female (5thile = 1500mm tall) could be seen to the front, offside and Passenger side of the truck (see Figure 62).

Relative approach

Option 3: The median volumetric score defines the 3 star boundary

Option 4: The median volumetric score defines the 1 star boundary

The two different sizes of human were initially selected to allow an exploration of whether there were fundamental differences between the way that vehicles performed close to the vehicle and further away from the vehicle, based upon the fact that a taller person would be able to stand closer to a vehicle and still be seen. This test was done for the full sample and there were no fundamental differences in the pattern of distances for 13 VRUs for taller and shorter human models i.e. the order of the results for performance for each model were the same.

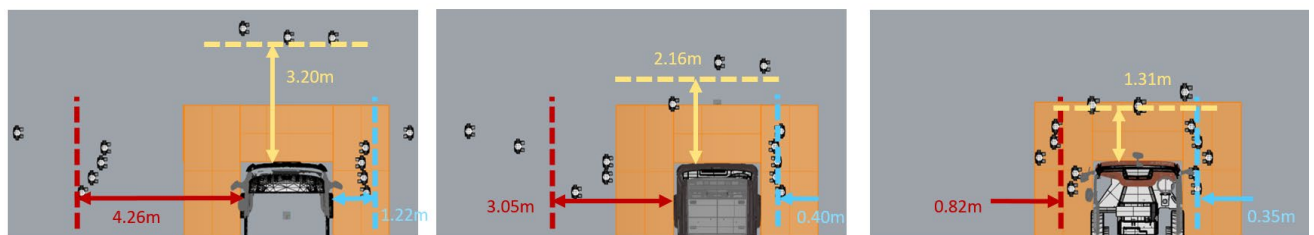

Figure 62. Images show average distances VRUs can be seen to each side of the cab for three vehicles using Option 2

THE DETAILED APPROACH USED TO FIND THE DVS RATING OF EACH VEHICLE AND DEFINE THE STAR RATING BOUNDARIES CONSIDERING OPTIONS 1-4

Options 1 and 2 consider the location of the VRUs as a way to quantify the volumetric scores, with the allocation of the boundary vehicles to a 1 star or 3 star boundary based upon the absolute or relative approach respectively. Options 3 and 4 consider the volumetric data alone, and apply either a 1 star or a 3 star the median volumetric value based upon the absolute or relative approach respectively. The following description of the methodology followed describes the approach for option 2. This option was selected as the approach that would be adopted for the DVS by the TfL Board in August of 2017. The decision was based upon the need to have an absolute approach which is seen to be as inclusive as possible. For example, if the option 1 had been adopted it would not be clear how the performance of the DVS would be quantified for the approximately half of the European population that are shorter than the 50thile UK male. In addition the absolute approach was defined as the preferred option as it uses a real world metric, the size of a set of humans that are visible to the driver from a certain distance, which varies based vehicle design, to determine a DVS score. Given than the final results for option 2 shown in section ++ highlight that over half of the vehicle sample were unable to meet the minimum requirement of 1 star, it was clear that vehicle design needs to improve to support direct vision. This effect is not demonstrated by a relative approach.

The approach that has been defined utilises and combines the results for the three directions of view (front, offside and nearside) that have been used in the volumetric assessment process, as suggested by manufacturers in the June 2017 stake holder event discussed in Section 7. Initially a threshold vehicle was identified which just meets the test of acceptability defined in Section 9.6 for each of the three viewing directions that have been included in the volumetric measurement of direct vision performance i.e. the front, passenger side and driver’s side of the truck.

This was done by taking the average of the VRU distances from the front, passenger side and driver’s side of the truck. For example, for the passenger side, the truck which had an average VRU distance value closest to the 4.5m cut off shown in Figure 51 was identified. In this case the value was 4.437m. All other trucks produced average VRU distances where the head and shoulders could be seen for the 5 nearside VRUs that were below 4.43m, or above 4.5m. The volume of the projection for the Passenger side for this one vehicle was then found from the data. This set a threshold volume for the Passenger side which was equated to the one star boundary for Option 3. The volumetric difference between the 1 star boundary limit and the highest volume was then subdivided equally to create the 2 star, 3 star, 4 star and 5 star boundaries. In the case of option 3, this subdivided the data between the threshold and the best performing vehicle’s volume into five. The division could have been into four equal sections, to represent the performance between 1-2, 2-3, 3-4 and 4-5 star. However, five divisions were considered to be more appropriate to reduce five star performance being reliant on a single vehicle; to ensure there was an opportunity for there to be more than one vehicle in the fleet that could be rated as five star, and encourage manufacturers to develop improved future vehicles aspiring to a five star rating. This is shown in Figure 63 (anonymised).

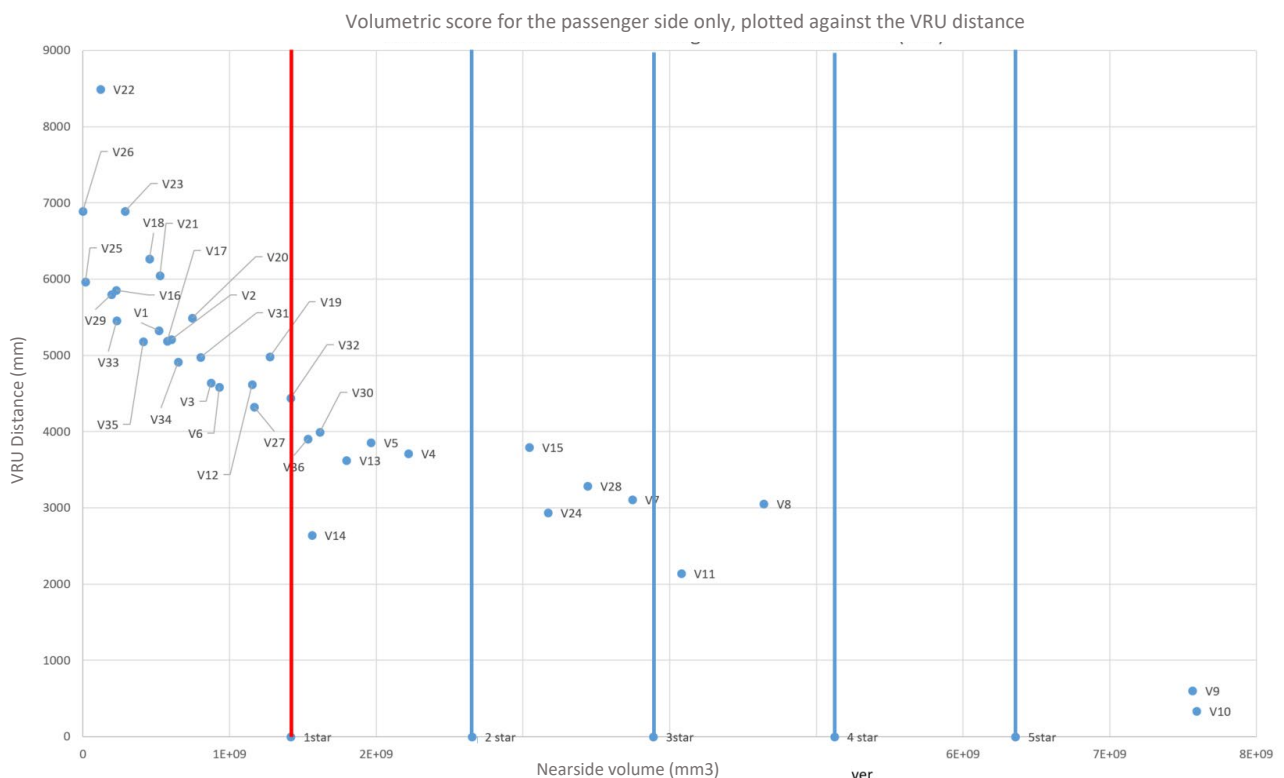

Figure 63. A graph showing the Average VRU distance to the Passenger side against the volumetric score for the Passenger side projections. The red line shows that V32 defined the 1 star boundary, with the other boundaries being created by a subdivision of the volume between V32 and the best performing vehicle, V10.

The star rating was then tabulated for each vehicle by seeing within which boundaries each vehicle falls as per Figure 63. This process was recreated for the front and offside projection data providing three separate star ratings for each vehicle. It was a requirement to do each side separately in this manner, as the front, offside and nearside all had different offsets which determined acceptability, (e.g. 4.5m to the nearside, and 2m to the front).

With the three star ratings produced it was then a requirement to combine the data to form an overall rating for each vehicle. The star ratings to the front, Passenger side and driver's side were then averaged to give an overall rating for each vehicle. The vehicle with the lowest volume result that achieves an average star rating of 1star was identified. The vehicle with the 1 star rating for the average of all sides, was then used to identify the volumetric result associated with 1 star for the combination of all three volumes. The volumetric difference between the 1 star boundary limit and the highest volume was then subdivided equally to create the 2 star, 3 star, 4 star and 5 star boundaries.

Therefore a vehicles final star rating is defined by the combined performance to all three of the areas around the cab, with the 1 star rating boundary being defined by direct vision performance in the VRU test.

The results for each of the four options are presented in the following sections.

RESULTS FOR OPTIONS 1.

The processing of the results for option 1 follows the method described in section 9.6.1 except that where boundary vehicles were assigned to a 1 star rating in Option 3, they were assigned a 3 star rating in Option 1.

Option 1 – Relative. Where the 3 star performance equates to the ability to see the head of an average sized UK male (50th%ile)

2m to the front of the cab, 600mm to the right and 3.25m to the left of the cab

3.25m was selected as the mid point between the two possible class V mirror coverage zones (2m or 4.5m) based upon Class V mirror height (see UNECE Regulation 46)

These criteria were used to produce a star rating for each of the sides which was then averaged to provide an overall rating which then defined the 3 star boundary in the graph below

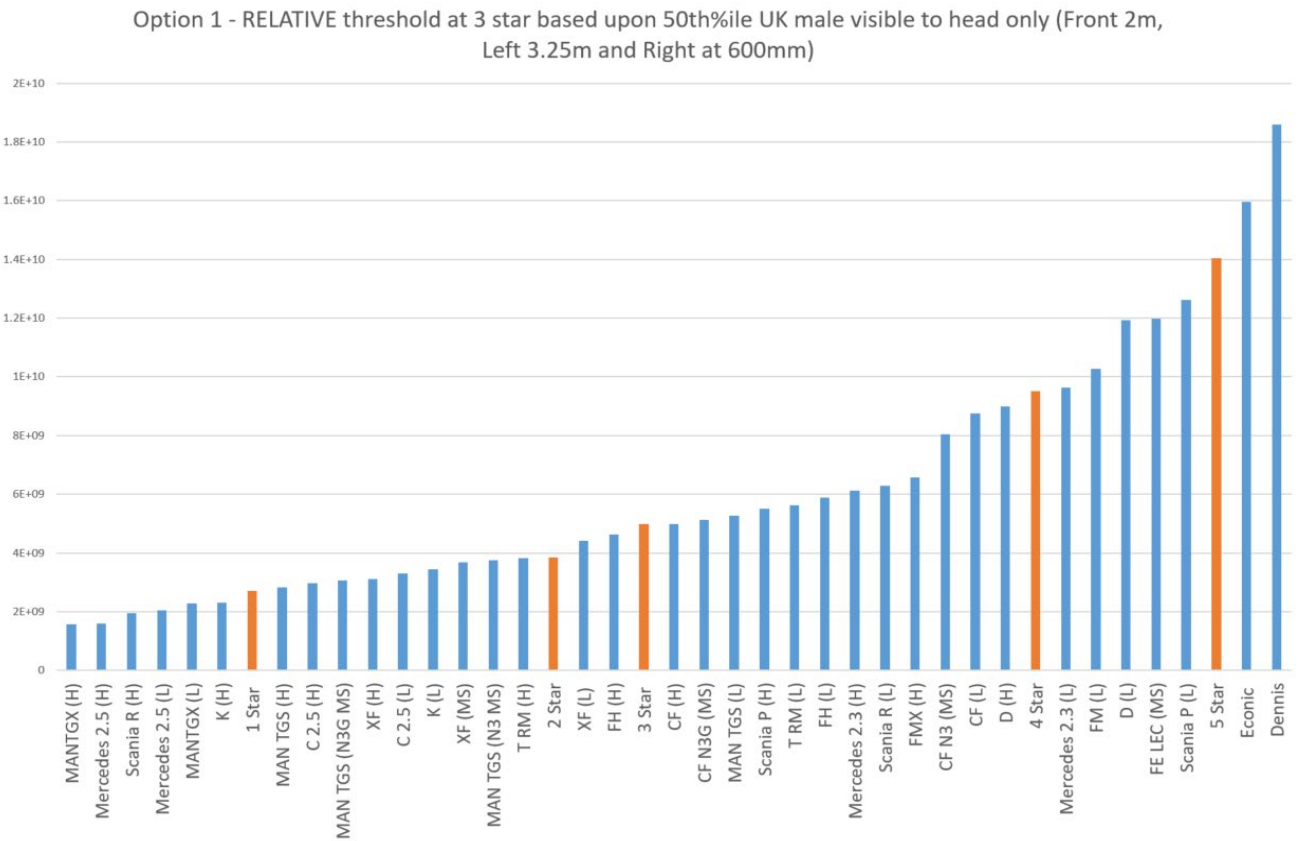

Figure 64. A graph showing the placement of the star boundaries for Option 1.

RESULTS FOR OPTION 2.

Option 2 – Absolute. Where the 1 star performance equates to the ability to see the head and shoulders of a 5thile Italian female

2m to the front, 600mm to the right and 4.5m to the left of the cab, linked to the Class V and VI Mirrors

These criteria were used to produce a star rating for each of the sides which was then averaged to provide an overall volume which then defined the 3 star boundary in the graph below

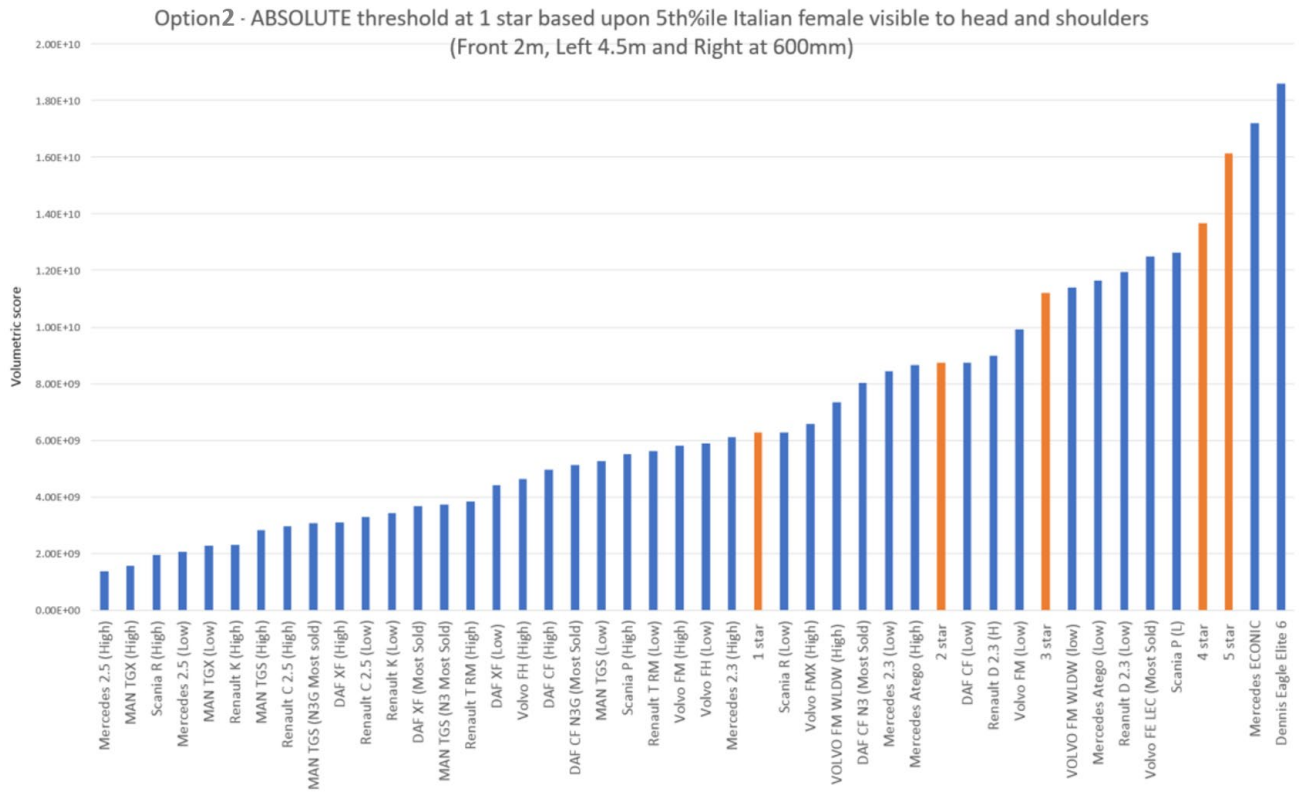

Figure 65. A graph showing the placement of the star boundaries for Option 3

RESULTS FOR OPTION 3.

Option 3 – Relative. Where the median volume for all trucks was used to define the 3 star boundary and the volume to the left and right of this boundary was equally divided

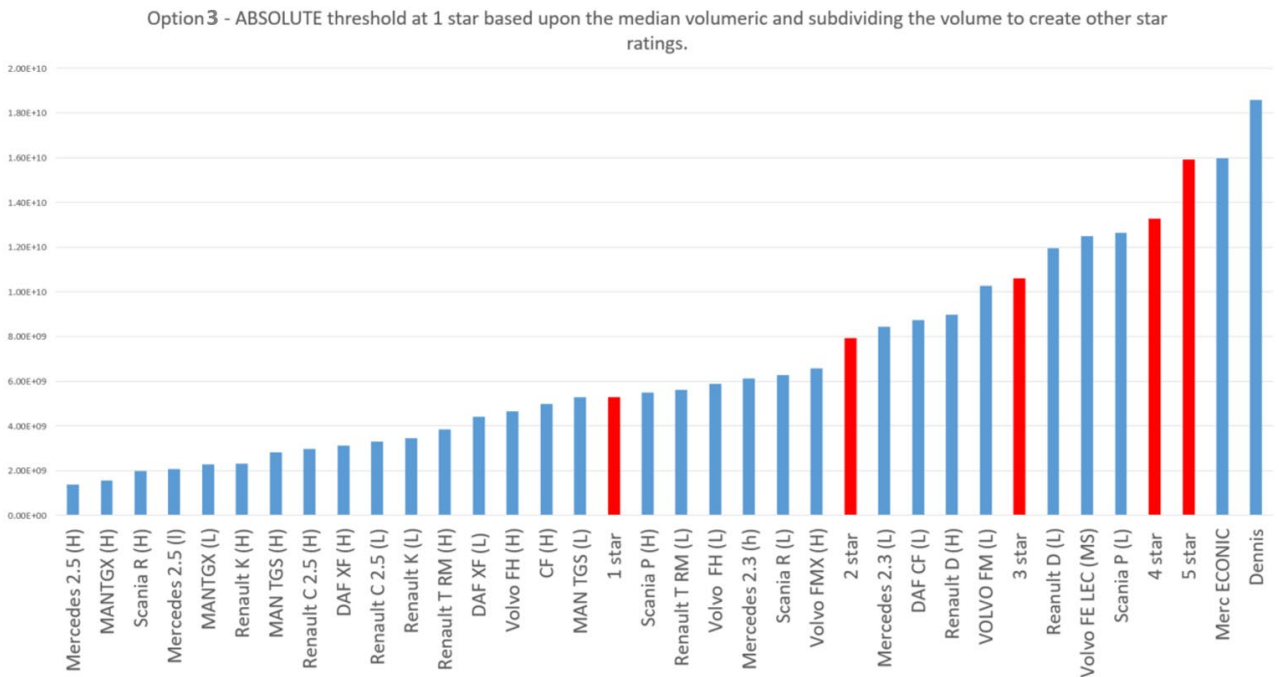

Figure 66. A graph showing the placement of the star boundaries for Option 2

RESULTS FOR OPTION 4.

Option 4 – Absolute. Where the median volume for all trucks was used to define the 1 star boundary and the volume to the left and right of this boundary was equally divided

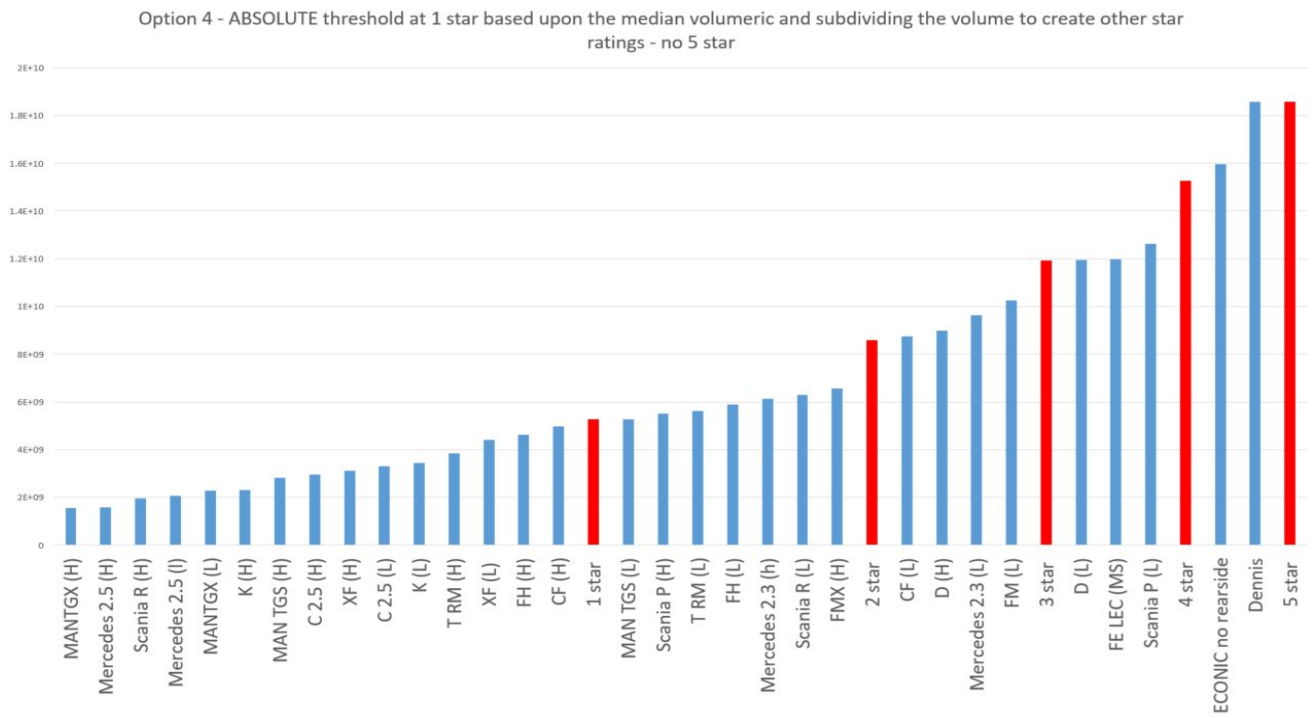

Figure 67. A graph showing the placement of the star boundaries for Option 4

FINAL SELECTED DVS OPTION SUBJECT TO CONSULTATION

As described in Section 9.6.1 the option selected by the TfL board was option 2. Option 2 utilises candidate 2 assessment zone with no weightings to generate the volumetric projection scores. Using an absolute approach meant that the DVS rating performance was based on what needs to be seen, rather than how well the vehicles currently on the road perform. This ensured that the DVS focused solely on safety and not on the current state of the industry. This approach was subsequently presented and agreed by all stakeholders.

D. DVS PROTOCOL

TFL DIRECT VISION STANDARD PROTOCOL V 3.0

Prepared on behalf of Transport for London

Prepared by: Dr Steve Summerskill
Dr Russell Marshall
Dr Abby Patterson
Anthony Eland
Dr James Lenard

Loughborough Design School, Loughborough University

TABLE OF CONTENTS

1	Definitions.....	3
1.1	Heavy Goods Vehicle (HGV).....	3
1.2	Vulnerable Road User (VRU).....	3
1.3	Direct field of View.....	3
1.4	Monocular Field of View	3
1.5	Day Light Opening (DLO) / Transparent Area	3
1.6	Sight Line	3
1.7	Vision Opening Line (VOL).....	3
1.8	Neck Pivot Point (P)	3
1.9	Cyclopean Eye Point	3
1.10	Eye Points (E POINTS).....	3
1.11	Accelerator Heel Point (AHP).....	4
1.12	Coordinate System.....	4
1.13	Ground Plane	4
1.14	Vehicle Running Order for Assessment	4
1.15	A pillar or B pillar	4
1.16	Cab height	4
1.17	Proxy Average Cab Height.....	5
1.18	Assessment Volume.....	5
1.19	Visible Volume.....	5
1.20	Direct Vision Volume	5
1.21	Measurement units.....	5
2	Direct Vision Standard: CAD Procedure.....	5
2.1	Introduction.....	5
2.2	Validating the CAD software being used to rate vehicles by manufacturers and other parties	5
2.3	Setting up a vehicle for the Evaluation	7

2.3.1	Preparing the cad data	7
2.3.2	Black off and fade off.....	7
2.3.3	Passenger seat adjustment position.....	8
2.3.4	the accelerator HEEL point (AHP).....	8
2.3.5	Steering Wheel Position	8
2.3.6	Mirror Adjustment.....	9
2.3.7	Proxy average Cab Height and ground plane	9
2.3.8	eye point locations.....	10
2.3.9	assessment volume.....	12
2.3.10	Producing three projections which represent the volume of space that is visible to the driver	14
2.3.11	Extruding visible shapes to eye point location to create visible volumes.....	16
2.4	Generating the Direct Vision Volumes.....	17
2.4.1	Calculating the volumetric score	18
2.5	Using the generic truck model to validate the use of CAD tools	18
2.6	Comparing the results found to the DVS standard rating boundaries.....	18
2.7	Method of reporting results to TfL.....	19
2.8	Appendix 1-the items excluded in the alignment of the assessment volume- From UNECE reg 46	20

1 DEFINITIONS

1.1 HEAVY GOODS VEHICLE (HGV)

A vehicle used for the carriage of goods and having a maximum mass exceeding 3.5 tonnes (defined as category N2 and N3 vehicles)

1.2 VULNERABLE ROAD USER (VRU)

Pedestrians, Pedal Cyclists and motorcycle riders.

1.3 DIRECT FIELD OF VIEW

The field of view seen without the aid of any devices

1.4 MONOCULAR FIELD OF VIEW

The field of view that can be seen by one eye. (Reference SAE J1050a)

1.5 DAY LIGHT OPENING (DLO) / TRANSPARENT AREA

An area of a vehicle, windscreen or other glazed surface, whose light transmittance measured at right angles to the surface is not less than 70 per cent. As defined in UN ECE Regulation 125.

1.6 SIGHT LINE

A line representing the driver's line of sight from an eye point or a V point to a target point or at a given angle.

1.7 VISION OPENING LINE (VOL)

What the driver actually perceives as the DLO. It is the intersection of a surface of interest and a sight line from a vision reference point, tangent to the first body component obstructing these sight lines (i.e., window mouldings, seals, ceramic paint, concealed wipers, front end surface, etc.)

1.8 NECK PIVOT POINT (P)

Point about which a driver's head turns on a horizontal plane. See Figure 8.

1.9 CYCLOPEAN EYE POINT

Midpoint between left and right eye points at centerline of driver.

1.10 EYE POINTS (E POINTS)

Three points representing the cyclopean eye point, used in conjunction with a Neck Pivot Point to describe specific viewing tasks. FEP= front eye point, LEP = left eye point, REP = right eye point. See Figure 8. The point from which sight lines may originate.

1.11 ACCELERATOR HEEL POINT (AHP)

A point on the shoe located at the intersection of the heel of shoe and the depressed floor covering, when the shoe tool is properly positioned. (Essentially, with the ball of foot contacting the lateral center line of the undepressed accelerator pedal, while the bottom of shoe is maintained on the pedal plane). As defined in SAE J1100.

1.12 COORDINATE SYSTEM

The three-dimensional vehicle coordinate system is that established in SAE J182.

1.13 GROUND PLANE

Horizontal plane parallel (XY) at ground level.

1.14 VEHICLE RUNNING ORDER FOR ASSESSMENT

The vehicle for evaluation should be defined in the appropriate running order including:

- the suspension enabling the vehicle ground clearance to be adjusted, if applicable, is set to the recommended setting for normal driving or, if this is not defined or defined as a position that is considered by the technical service unlikely for use by most drivers, the setting closest to its medium range between highest and lowest position
- the specified tyres should be at their minimum available ETRTO diameter for the tyre profile and tread type specified at the point of purchase.
- the tyre pressures are set according to manufacturer's recommendations
- the fuel tank is filled to at least 90% of the capacity specified by the manufacturer
- other fluid levels, such as lubricants, coolants, etc., are set according to manufacturer's recommendations
- the driver's seat is occupied with a driver of 75 kg mass
- no additional payload or passenger's ballast is added

The mass of a vehicle in running order includes the mass of the vehicle and its body with cooling fluid, lubricants, fuel, 100 per cent of other liquids, and driver. The mass of the driver is evaluated at 75 kg, in accordance with UN ECE Regulation 51. The fuel tank contains 90 per cent and the other liquid-containing appliances 100 per cent of the capacity declared by the manufacturer.

1.15 A PILLAR OR B PILLAR

Roof supports including non-transparent items such as windscreen mouldings and door frames, attached or contiguous to such a support.

1.16 CAB HEIGHT

Vertical height in Z between the ground plane and the AHP.

1.17 PROXY AVERAGE CAB HEIGHT

The proxy average height is defined as the mean height between the maximum loaded state of a vehicle (technical design maximum) and the minimum unloaded state of a vehicle (unladen chassis cab) as shown in Figure 6.

1.18 ASSESSMENT VOLUME

A volume around the evaluation vehicle defining the volume of space that needs to be seen by the driver in order to view VRUs within the area of greatest risk. The assessment volume is defined by accident scenarios and by the area of indirect vision requirements defined in UN ECE Regulation 46.

1.19 VISIBLE VOLUME

A representation of the visible volume of space afforded the driver through a VOL from the relevant eye point.

1.20 DIRECT VISION VOLUME

The resulting volume representing the proportion of the assessment volume that can be seen by the driver to the front, left and right. Formed by intersecting the assessment volume with the visible volumes.

1.21 MEASUREMENT UNITS

Linear measurements are all stated in mm. Angular measurements are stated in degrees. Volumetric measurements are stated in m³.

2 DIRECT VISION STANDARD: CAD PROCEDURE

2.1 INTRODUCTION

The protocol describes the method by which a TfL Direct Vision Standard (DVS) rating can be determined for single configuration of an HGV cab design. The DVS is a method by which the direct vision performance of a cab design can be compared to a minimum performance standard of a 1 star rating, with performance above the minimum requirement being defined by star ratings between 2 and 5. The methodology by which the star rating system has been defined can be reviewed in the final project report.

2.2 VALIDATING THE CAD SOFTWARE BEING USED TO RATE VEHICLES BY MANUFACTURERS AND OTHER PARTIES

The TfL DVS standard rating protocol can be tested using a variety of CAD based systems. There is a requirement to ensure that the results from these different systems are equivalent.

Therefore, the authors of the protocol have created a generic truck model (see Figure 1) which can be tested with any CAD system, and the result can be then be compared to results generated by the authors of the protocol. The authors of the protocol have performed the DVS testing process using Rhinoceros V5 (<https://www.rhino3d.co.uk/>). This is the recommended tool for the analysis. The result which should be

matched by CAD systems other than Rhinoceros V5 can be seen in section 2.5. A range of other tools can complete the analysis to the recommended level of resolution, including RAMSIS and CATIA (when used with the additional CAVA addon).

Figure 1 shows the generic truck cab that has been produced and highlights the key features that have been included.

This generic truck model should be tested using the manufacturers systems before ratings are attempted.

The following sections outline the test protocol.

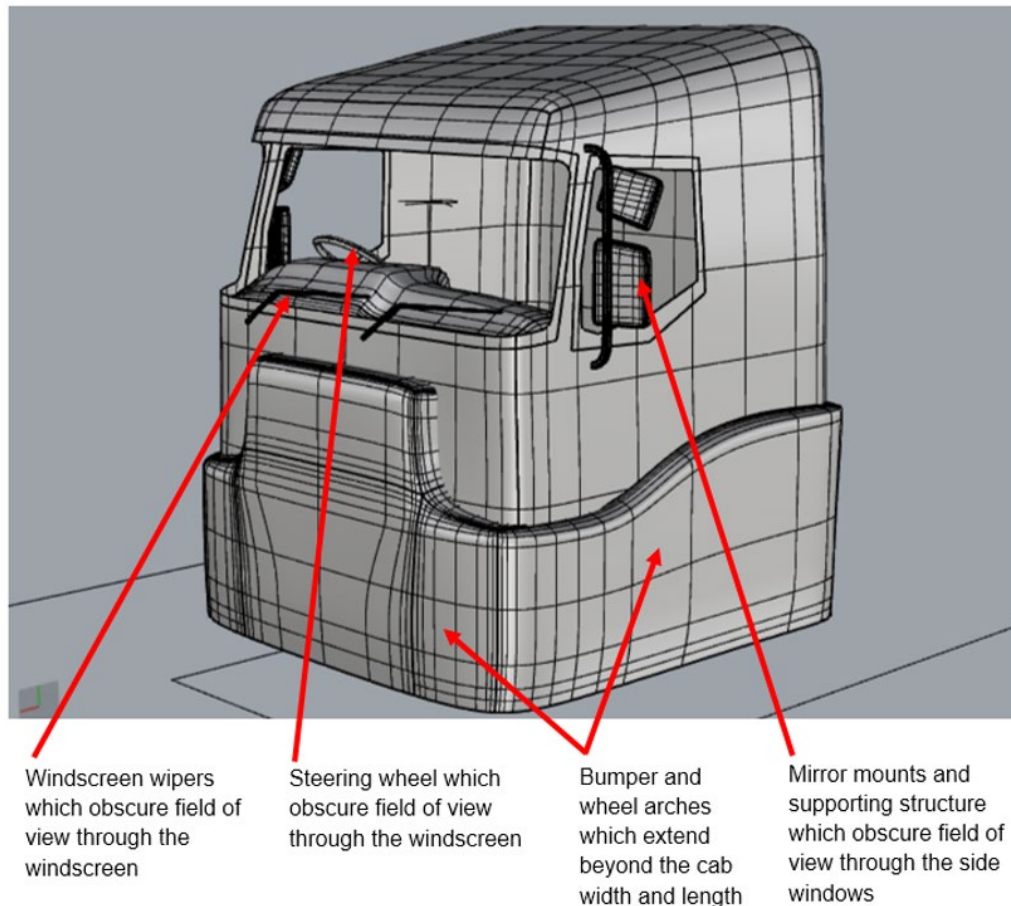

Figure 1. The key features of the generic truck cab model

2.3 SETTING UP A VEHICLE FOR THE EVALUATION

The Vehicle shall be set up in running order as defined in section 1.14. The assessment vehicle shall be configured in the following manner to enable evaluation of its direct vision performance and generation of its DVS rating.

2.3.1 PREPARING THE CAD DATA

It is essential that the model used for the evaluation includes all necessary geometry to provide a representative interior and exterior cab. The model file should include any geometry which can obscure the field of view from the driver's position, see Figure 2. In particular the model should include the following elements:

- Exterior panels that bound any transparent area
- Exterior panels that define the extents of the vehicle to the front (bumper) and sides (wheel arches)
- Exterior elements that may occlude driver vision including mirrors and mirror arms, wipers and any other manufacturer fit feature or equipment
- Interior surfaces that may occlude driver vision including: the dashboard, window seals / rubbers, trim panels on doors, A-pillars, B-pillars, grab handles
- A representation of the boundary of the windscreen black off / fade off
- Interior equipment that may occlude driver vision including rain sensors, screens or other controls or displays.
- Key elements of the driver packaging including seats (driver and passenger), steering wheel, AHP



Figure 2. Example CAD data that is required for the DVS assessment

2.3.2 BLACK OFF AND FADE OFF

The window frit or 'fade off & black off' shall be included in the analysis and be considered opaque. Thus, the assessment aperture is defined by the inner boundary of any patterned area, see Figure 3.

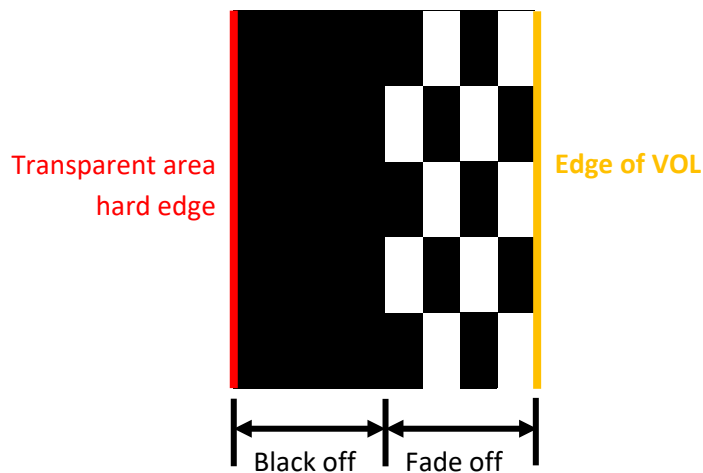

Figure 3. Black off and fade off of a transparent area and its impact on the VOL

2.3.3 PASSENGER SEAT ADJUSTMENT POSITION

The passenger seat may present an obscuration to driver vision for any of the passenger side windows and should therefore be considered in the evaluation.

For vehicles where a range of passenger seat types may be specified, the seat selected for evaluation is at the discretion of the manufacturer. The seat must also be a genuine option available for purchase, it cannot be a custom specification purely for the purposes of the DVS.

If the position of the seat is adjustable the passenger seat shall be placed at its rearmost lowest position with a backrest angle of 18 degrees from vertical.

Where a foldable passenger seat is available the seat may be in the in-use (deployed) or the not-in-use (stowed) position at the manufacturers discretion.

Where adjustable armrests are available these may be in the in-use (deployed) or the not-in-use (stowed) position at the manufacturers discretion.

Head restraints shall be in the lowest deployed position.

2.3.4 THE ACCELERATOR HEEL POINT (AHP)

An AHP shall be included in the CAD model. The AHP is a key reference point for the definition of the eye points used for the evaluation and shall be defined as per the process documented in SAE J1516, SAE J1517 and SAE J1100.

2.3.5 STEERING WHEEL POSITION

The steering wheel shall be located in the central adjustment position for all types of adjustability as shown in Figure 4.

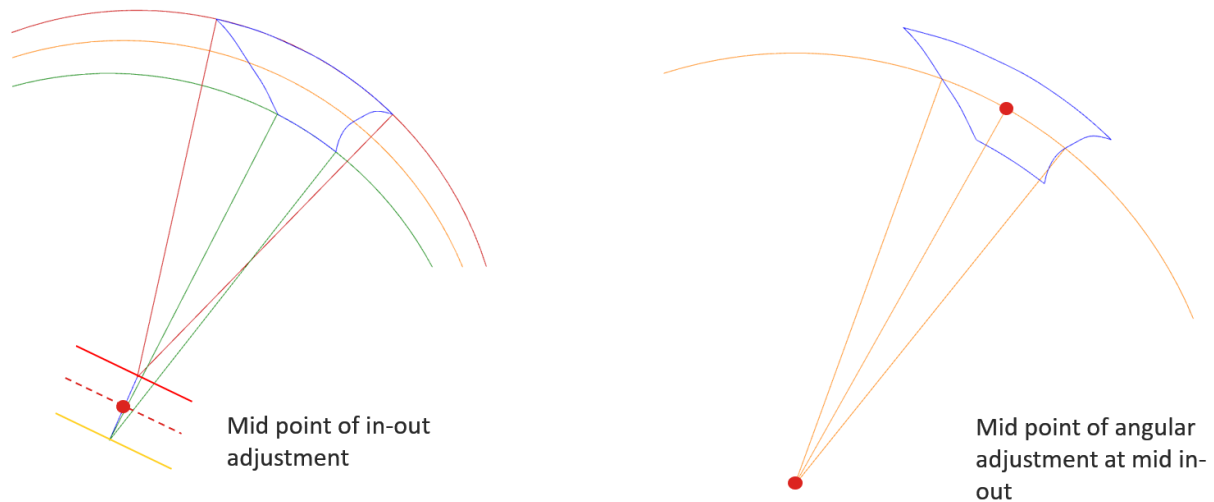

Figure 4. The steering wheel shall be adjusted to the mid-point of all adjustable ranges (in-out adjustment and angular adjustment).

2.3.6 MIRROR ADJUSTMENT

Mirrors shall be adjusted to meet the view requirements specified in UN ECE Regulation 46.

2.3.7 PROXY AVERAGE CAB HEIGHT ABOVE GROUND PLANE

For a given vehicle to be evaluated the assessment should be performed for the range of cab mounting heights of the AHP above the ground plane (Figure 5). The height range available will be subject to the manufacturers specified axle, suspension and tyre configurations. The height for a single configuration shall be defined by a proxy average to take into account the effects of loading, and the frame and cab should be horizontal. In addition the running order definition shown in section 1.14 shall be applied.

The proxy average (Z_p) is defined as the mean value between the technical design maximum, by front axle only, (Z_{dm}) and the unladen chassis cab (Z_u) as shown in Figure 6. Thus, for a given nominal cab height h , the proxy average is given by the following equation:

$$Z_{ph} = (Z_{uh} - Z_{dm}h) / 2$$

Each nominal height shall be determined by the manufacturer's specifications for axle and suspension.

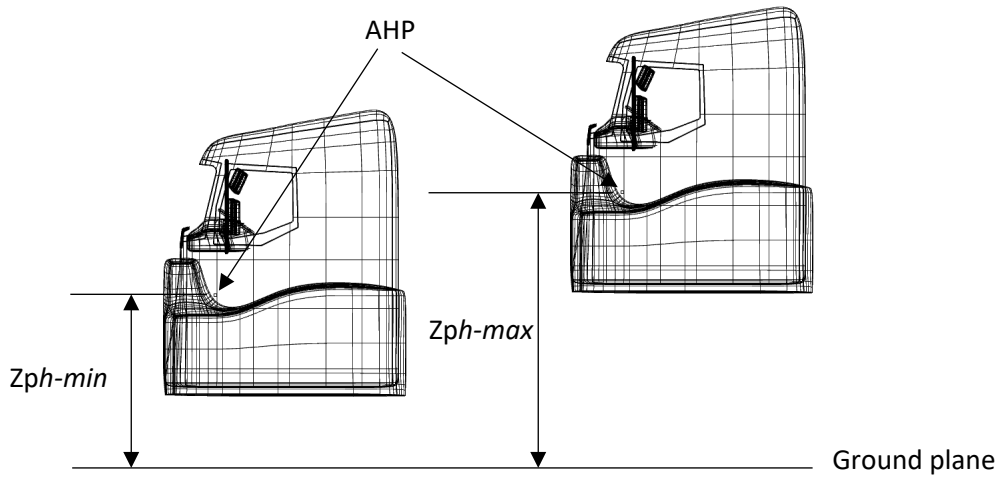

Figure 5. Assessment height range between the proxy average maximum vehicle height (Z_{ph-max}) and the proxy average minimum vehicle height (Z_{ph-min})

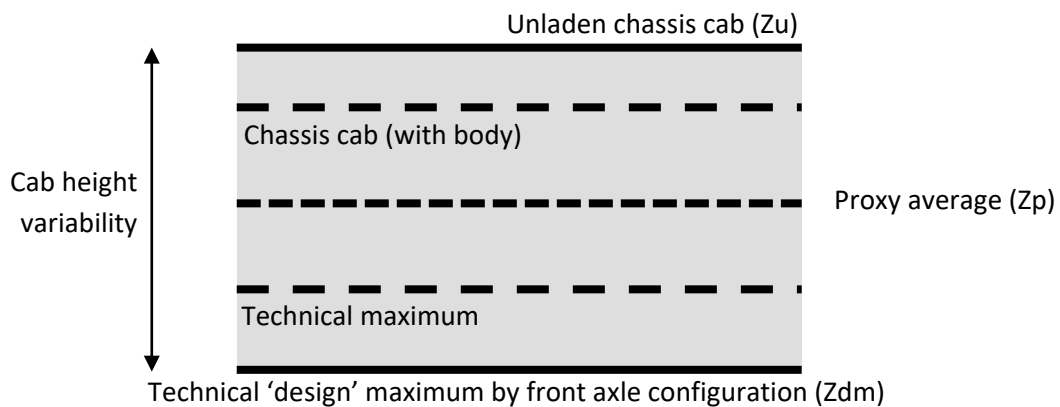

Figure 6. Proxy average cab height definition

Tyre height shall be taken as the make and profile specified at the point of purchase. The Proxy average height calculation shall include the variability in tyre diameter at the extremes of loading by the Chassis cab with body, and the technical maximum loading.

2.3.8 EYE POINT LOCATIONS

The field of view of the driver shall be defined by cyclopean monocular vision from a total of three eyepoints from which sight lines will originate. The three eyepoints represent a forward field of view and a head turn to the left and right respectively.

The global forward eye point (FEP_{xg} and FEP_{zg}) shall be defined as an offset from the AHP (AHP_{xg} and AHP_{zg}) according to the following equations:

$$FEP_{xg} = AHP_{xg} + 678$$

$$FEP_{zg} = AHP_{zg} + 1163.25$$

The eye point is located in the Y axis in line with the central plane of the seat.

The forward eye point (FEP) is defined as an offset from the AHP of 678mm in X and 1163.25mm in Z as shown by Figure 7.

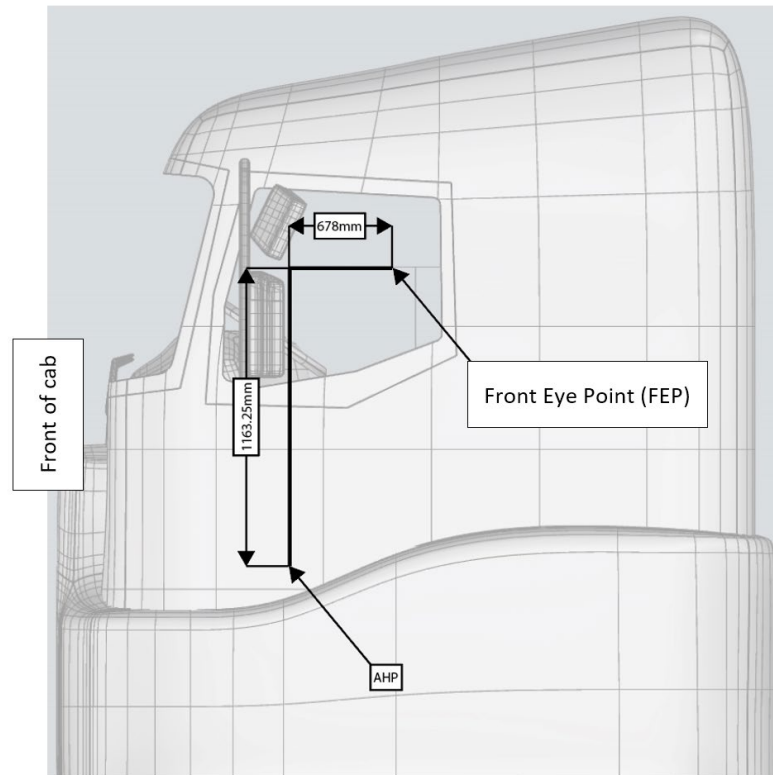

Figure 7. The vertical and horizontal offset from the AHP to the eye point

Head rotation is accounted for through the left and right eye points. These shall be established by the determination of a neck pivot point P according to SAE J1050. The point P is located 98mm rearwards of FEP.

The left (LEP) and right eye (REP) points are defined by a 60 degree rotation of the head about the neck as shown in Figure 8.

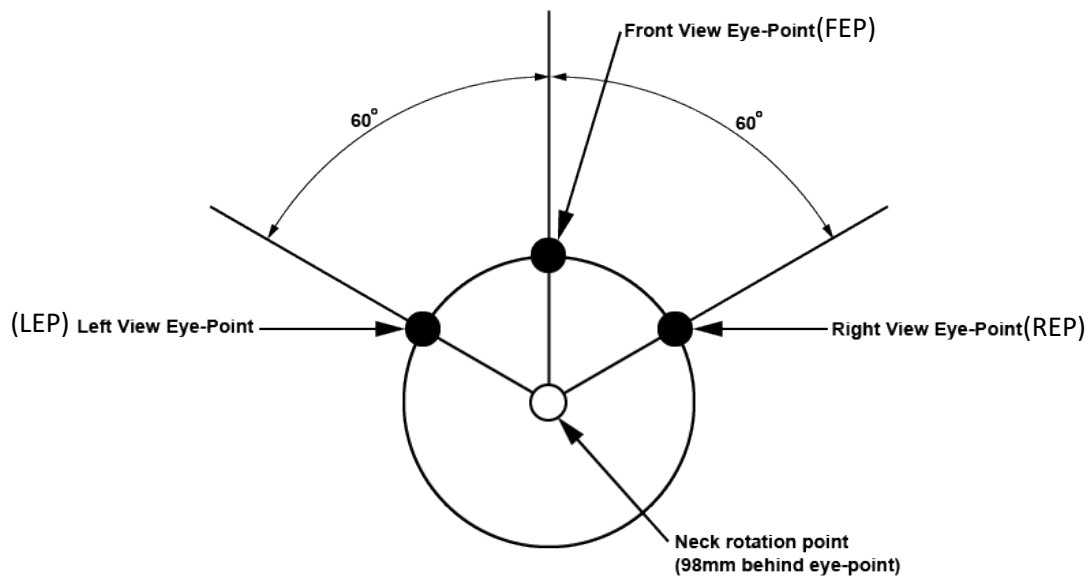

Figure 8. Plan view of the three eye point definitions

2.3.9 ASSESSMENT VOLUME.

The assessment volume shall be defined as an offset from the extents of the vehicle as shown in Figure 9.

The extents of the vehicle shall be used to define an exclusion area from which the assessment volume is offset.

- The front limit of the exclusion area is defined by a plane parallel to ZY, perpendicular to the ground plane, which is touching the foremost point of the vehicle structure.
- The passenger and driver side limits of the exclusion area are defined by planes parallel to ZX, perpendicular to the ground plane, which are touching the most lateral points of the vehicle structure.
- The limits of the vehicle shall include bumpers, and mud guards but exclude all features listed in Appendix 1.

The assessment volume covers an area analogous to the area specified in UN ECE Regulation 46 for indirect vision:

- The area is offset from the front of the cab by 2m in X
- The area is offset from the driver's side of the cab by 2m in Y
- The area is offset from the passenger side of the cab by 4.5m in Y
- The area extends 1m rearwards of the FEP

The assessment volume shall be formed through inclusion of the defined area at a height of Z=0 through to Z=1602mm as shown in Figure 9.

Right hand drive vehicle (UK, Japan, etc)

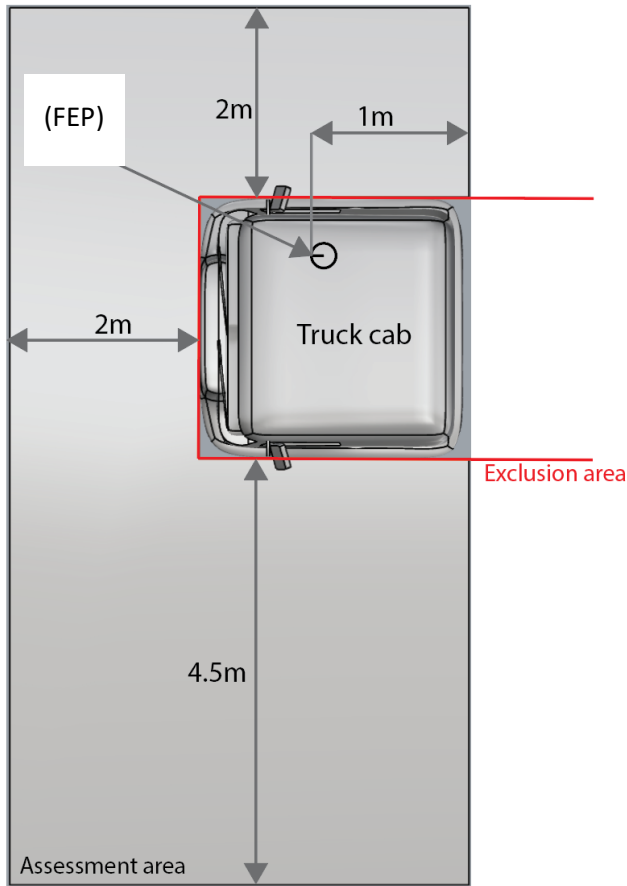

Left hand drive vehicle (EU, USA, etc)

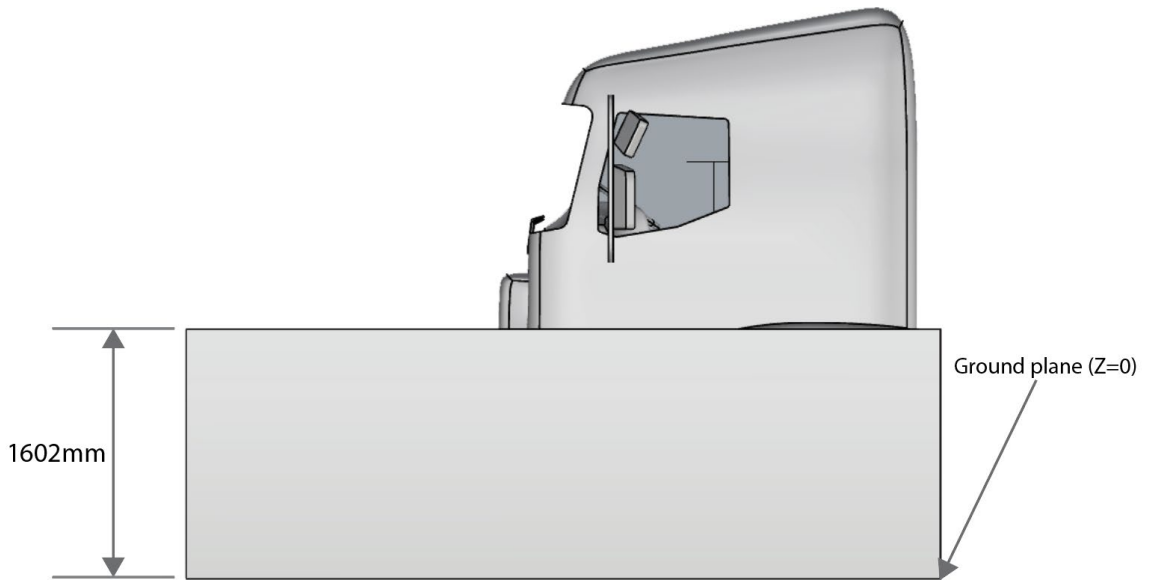
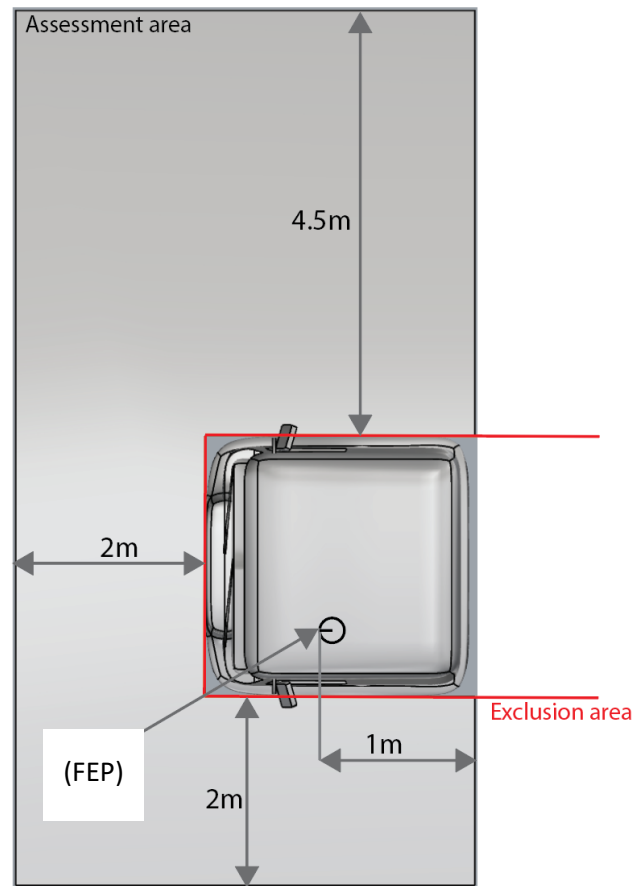

Figure 9. The definition of the assessment volume

2.3.10 PRODUCING THREE PROJECTIONS WHICH REPRESENT THE VOLUME OF SPACE THAT IS VISIBLE TO THE DRIVER

Using appropriate software tools (e.g. CAVA in CATIA, Mesh Outline in Rhinoceros 3D, RAMSIS or other such tools in Computer Aided Design software packages) create VOLs for each DLO set as defined in Figure 13. See Figure 10, Figure 11 and Figure 12 for the VOLs.

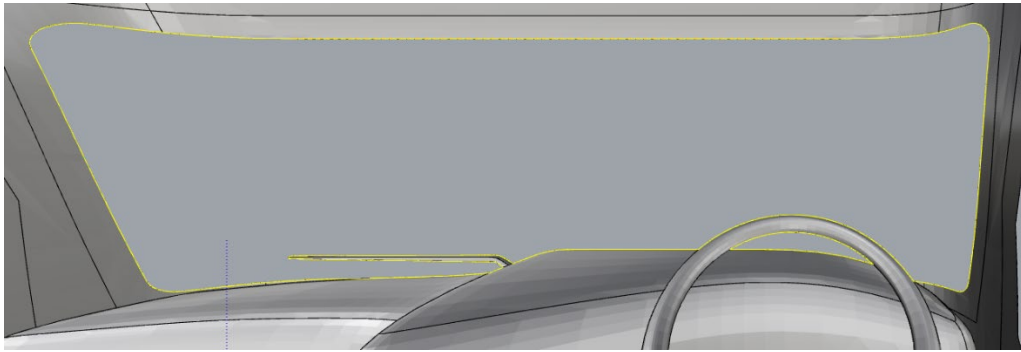

Figure 10. Creating the VOL (yellow path) for the windscreen, including the space between the steering wheel and the dashboard and accounting for the obscuration effect of the windscreen wiper

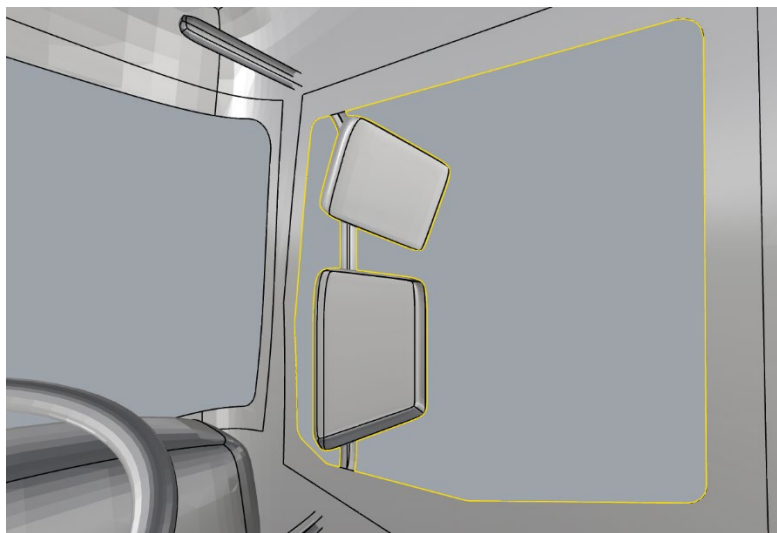

Figure 11. The result of the VOL generation for the driver's window (yellow path)

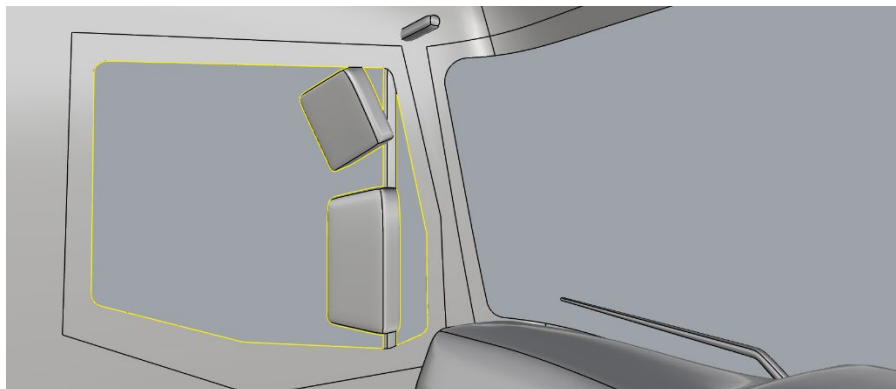

Figure 12. The result of the VOL generation for the passenger side window (yellow path)

The VOLs must be defined from the relevant eye point.

- The front view will involve the projection of the windscreen VOL only using the FEP
- The left view will involve the projection of the left DLOs using the LEP
- The right view will involve the projection of the right DLOs using the REP
- On the passenger side of the vehicle any DLO can be included in the analysis
- On the driver’s side of the vehicle any DLOs forward of the B-pillar can be included in the analysis
- Any DLO within the split A-pillar should be considered as part of the respective side projections i.e. Left split a-pillar DLO should be projected with the LE and the right split A-pillar DLO should be projected with the REP. See Figure 13.

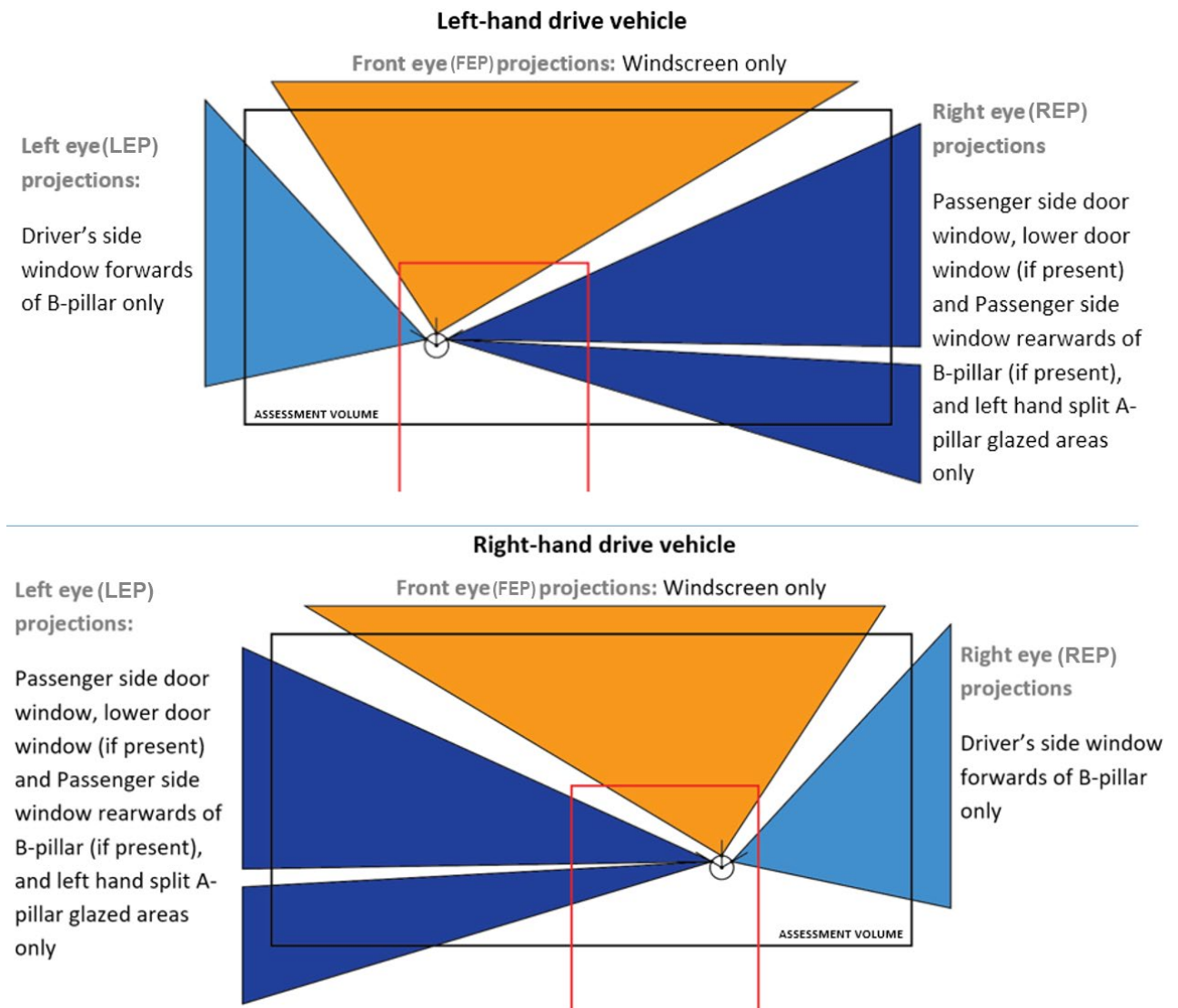

Figure 13. Left-hand and right-hand drive vehicles: Plan view of the windows which should be projected with each eye point

2.3.11 EXTRUDING VISIBLE SHAPES TO EYE POINT LOCATION TO CREATE VISIBLE VOLUMES.

Using the VOLs that have been produced a solid object should be generated by extruding the outlines to the relevant eye point location to define a visible volume. The sight lines that define the VLO must project beyond the limits of the assessment volume as shown Figure 14, Figure 15 and Figure 16.

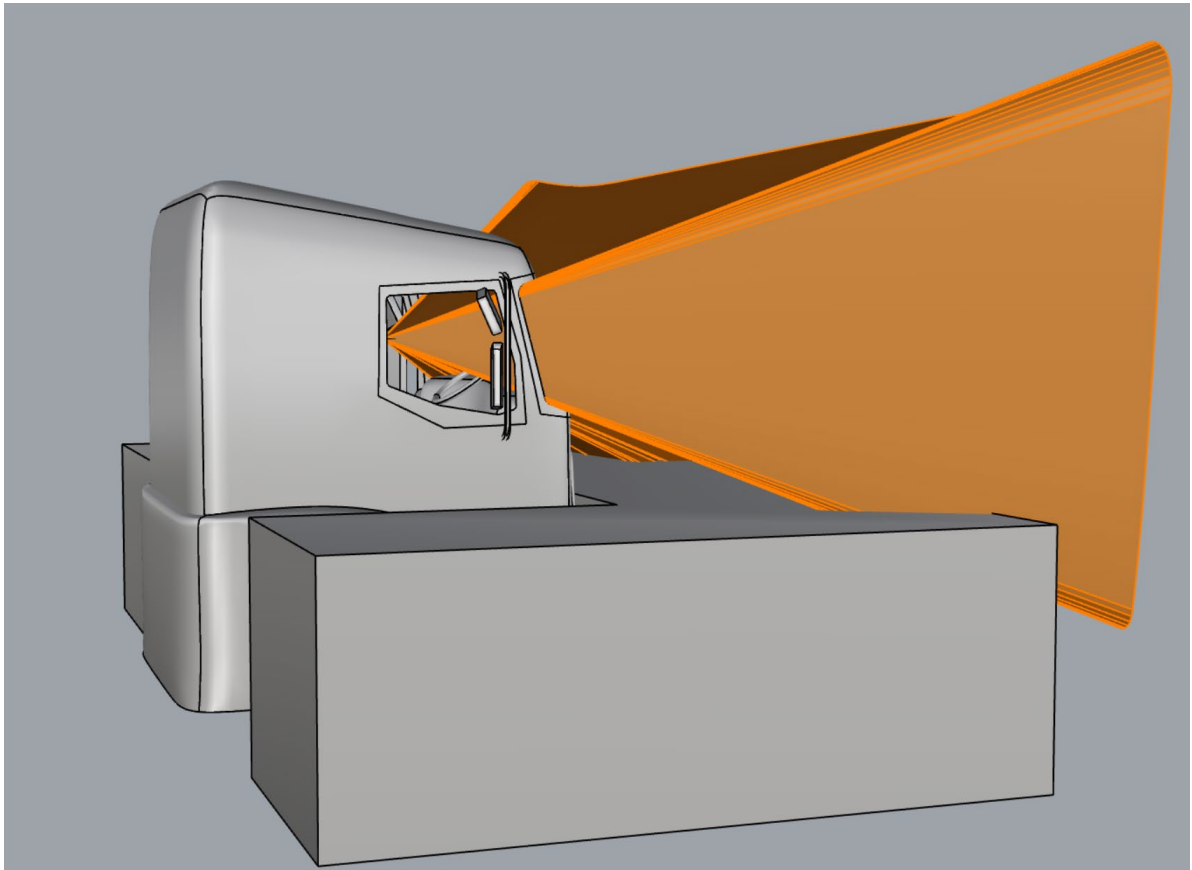

Figure 14. The windscreen VOL and Front Eye-point (FEP) used to create the front visible volumes.

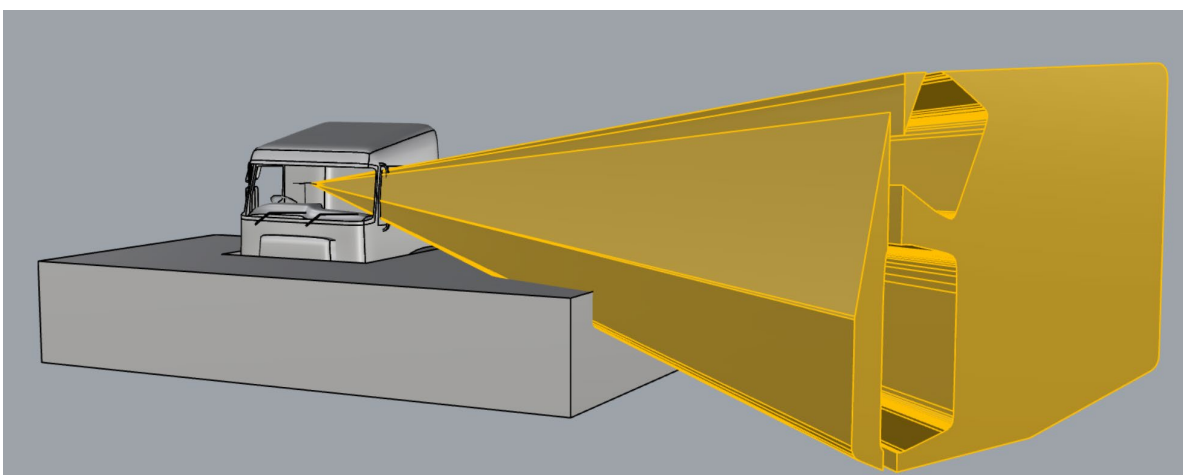

Figure 15. The left side window VOLs and Left Eye-point (LEP) used to create the left visible volumes.

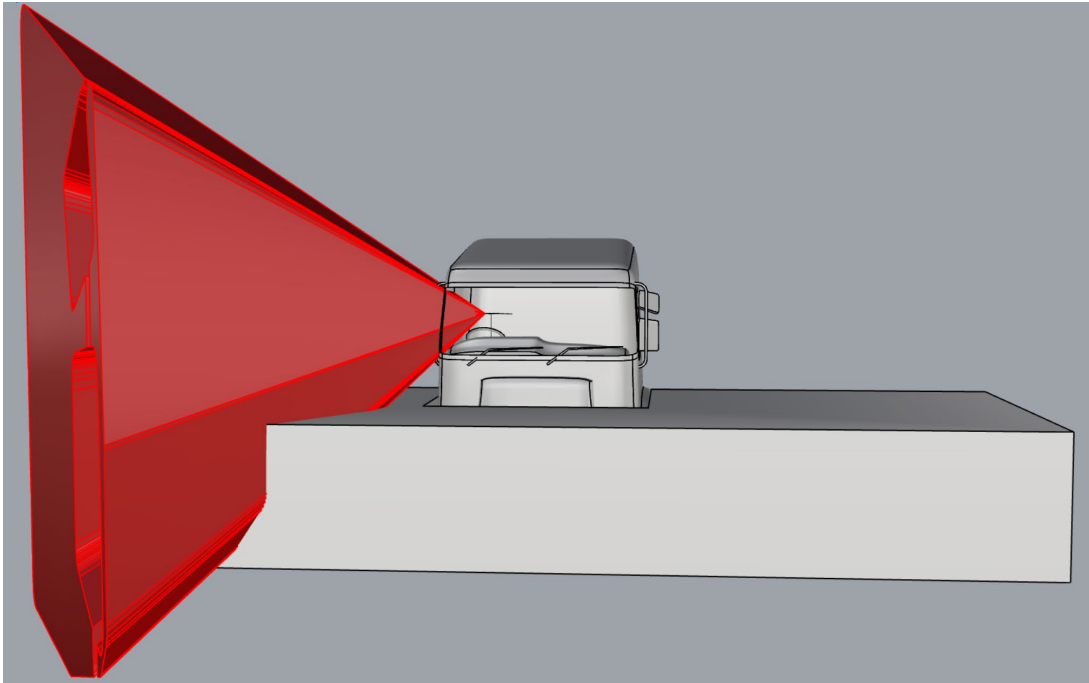

Figure 16. The right side window VOLs and Right Eye-point (REP) used to create the right visible volumes.

2.4 GENERATING THE DIRECT VISION VOLUMES.

The visible volume and assessment volume should be intersected (Boolean intersection operation – i.e. common volume) to define the direct vision volumes i.e. the sections of the assessment volume which are visible from the defined eye points (LEP, FEP and REP). The Front, Left and Right visible volumes should be intersected with copies of the assessment volume and should not be combined (to account for overlap of volumes behind the A pillars). The result is shown in Figure 17.

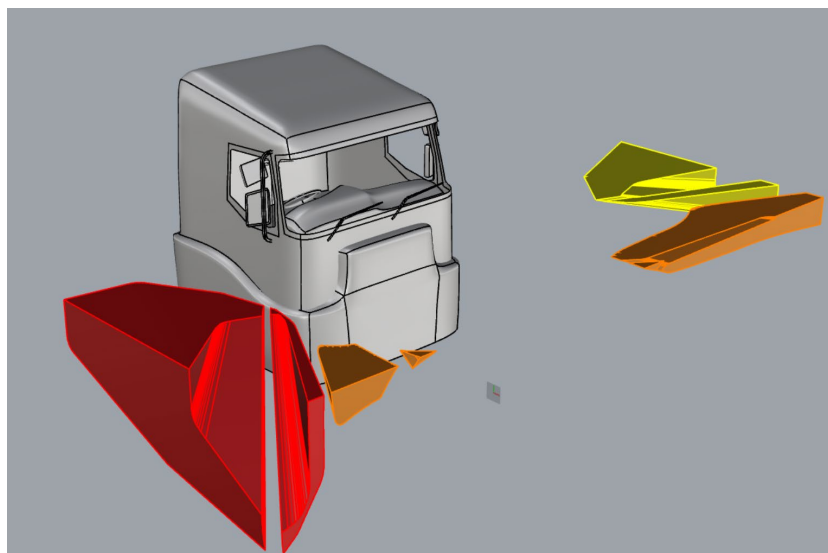

Figure 17. The direct vision volumes. Red volume (right), orange volume (front), and the yellow volume (left)

2.4.1 CALCULATING THE VOLUMETRIC SCORE

The size of the direct vision volumes should be calculated and recorded.

2.5 USING THE GENERIC TRUCK MODEL TO VALIDATE THE USE OF CAD TOOLS

The assessment process shall be verified through the use of the generic truck CAD model to ensure consistency between applications of the protocol in different software. The protocol should be applied in the same manner as per a manufacturers vehicle. The predetermined nominal volume results for the direct vision volumes for the three directions are shown in Table 1.

View direction	Nominal Volume (mm ³)	Allowable limits (mm ³)	
		≥	≤
Front	403613754	391505341	415722167
Right	1979890250	1920493543	2039286958
Left	664547484	644611059	684483909
Total	3048051488	2956609943	3139493033

Table 1. The volumetric results for the direct vision volumes generated from the generic truck

In order for a CAD tool to be deemed suitable for the production of DVS ratings it must produce results that are no greater than $\pm 0.3\%$ different from the nominal volumes. The limits of acceptable variability are shown in the right hand columns of Table 1.

2.6 COMPARING THE RESULTS FOUND TO THE DVS STANDARD RATING BOUNDARIES

The result for the combined total direct vision volumes for the front, left and right views for each analysis should be compared to the values found in Table 2 to allow a star rating to be determined. The table shows the star rating boundaries volumetric values.

To account for unspecified variability within the DVS process in addition to the limits shown in Table 1 all of the star boundaries include a 1% tolerance below the nominal boundary volumes.

	Star boundary volumes ≥ (m ³)	Limits including 1% tolerance (m ³)	
		≥	<
1 star	10.041212266	9.940800143	11.875780493
2 star	11.995737871	11.875780493	13.810760842
3 star	13.950263477	13.810760842	15.745741191
4 star	15.904789082	15.745741191	17.680721540
5 star	17.859314687	17.680721540	

Table 2. The star rating boundaries (mm³)

Therefore, a volumetric score that is, for example, between 11.875780493 m³ and 13.810760842 m³ would be rated 2 star, a volumetric score that is greater than 17.680721540 m³ would be rated 5 star and a volumetric score that is less than 9.940800143 mm³ would be rated zero star.

2.7 METHOD OF REPORTING RESULTS TO TFL

The following should be submitted to TfL.

1. The maximum Proxy Cab height for each vehicle model
2. The minimum Proxy Cab height for each vehicle model
3. The specific results that are associated with each vehicle for which an operator has requested a star rating.

These should be submitted using the table shown in Table 3.

Vehicle Make	Vehicle Model	Date			
Maximum Proxy Cab height (ground to AHP)	Right Volume (m ³)	Front Volume (m ³)	Left Volume (m ³)	Total (m ³)	Star Rating
Minimum Proxy Cab height (ground to AHP)					
Proxy Cab height for a Specific vehicle as requested by a customer					

Table 3. DVS Results reporting form

The table submission to TfL should include three screen shots taken from the three eye points RE, FE, LE clearly showing the driver's view of the cab and the VOLs as shown in Figure 10, Figure 11 and Figure 12 if this is possible in the software used to generate the results. If this is not possible then submit perspective views of the final visible volume.

Note: The Loughborough University team have defined a process by which the calculation all volumetric results for all possible cab mounting heights can be completed automatically in Rhinoceros 3D using the Grasshopper addon. This takes approximately 2 seconds per height value at increments of 1mm. This can improve the workflow associated with calculating multiple DVS results. Please contact the Loughborough University Design School team for more information. (s.j.summerskill2@lboro.ac.uk)

2.8 APPENDIX 1-THE ITEMS EXCLUDED IN THE ALIGNMENT OF THE ASSESSMENT VOLUME- FROM UNECE REG 46

1.1. "Structural length" means a dimension which is measured according to ISO standard 612-1978, term No 6.1. In addition to the provisions of that standard, when measuring the vehicle structural length the following devices shall not be taken into account:

- wiper and washer devices,
- front or rear marker-plates,
- customs sealing devices and their protection,
- devices for securing the load restraint(s)/cover(s) and their protection,
- lighting and light signalling devices,
- mirrors or other devices for indirect vision,
- reversing aids,
- air-intake pipes,
- length stops for demountable bodies,
- access steps and hand-holds,
- ram rubbers and similar equipment,
- lifting platforms, access ramps and similar equipment in running order, not exceeding 300 mm,
- coupling and recovery towing devices for power driven vehicles,
- trolleybus current collection devices in their elevated and retracted positions,
- external sun visors,
- de-mountable spoilers,
- exhaust pipes.

1.2. "Overall length" means a dimension so as to take the devices mentioned in paragraph 1.1. into account.

2. Vehicle width

2.1. "Structural width" means a dimension which is measured according to ISO standard 612-1978, term No. 6.2. In addition to the provisions of that standard, when measuring the vehicle structural width the following devices shall not be taken into account:

- customs sealing devices and their protection,
- devices for securing the tarpaulin and their protection,
- tyre failure tell-tale devices,
- protruding flexible parts of a spray-suppression system,
- lighting and light signalling devices,
- for buses, access ramps, lifting platforms and similar equipment in their stowed position.
- rear-view mirrors or other devices for indirect vision,
- tyre-pressure indicators,
- retractable steps,

- the deflected part of the tyre walls immediately above the point of contact with the ground,
- external lateral guidance devices of guided buses,
- running boards,
- de-mountable mudguard broadening.