

**DOSIMETRIC EVALUATION OF BLADDER AND  
RECTAL RADIATION DOSE IN CARCINOMA CERVIX  
PATIENTS USING ORTHOGONAL RADIOGRAPHS  
AND CT PLANNING IN HDR BRACHYTHERAPY**

*Institution*

**DEPARTMENT OF RADIOTHERAPY  
BERNARD INSTITUTE OF  
RADIOLOGY & ONCOLOGY  
MADRAS MEDICAL COLLEGE**

**&**

**GOVERNMENT GENERAL HOSPITAL  
CHENNAI – 600 003.**

*Dissertation submitted in partial fulfillment of*  
**MD BRANCH IX (RADIOTHERAPY) EXAMINATION**

**APRIL 2010**



**The Tamil Nadu Dr. M.G.R. Medical University  
Chennai – 600 032.**

## **CERTIFICATE**

This is to certify that the dissertation entitled  
**“DOSIMETRIC EVALUATION OF BLADDER AND RECTAL  
RADIATION DOSE IN CARCINOMA CERVIX PATIENTS  
USING ORTHOGONAL RADIOGRAPHS AND CT PLANNING IN  
HDR BRACHYTHERAPY”** is a bonafide work done by  
**DR. S. Madhumathi**, Post Graduate Student, Department of  
Radiotherapy, Madras Medical College, Chennai-3, in partial  
fulfillment of the University Rules and Regulations for the award of  
MD Branch – IX (RADIOTHERAPY) , under our guidance and  
supervision, during the academic period from May 2009 to April  
2011.

**Prof. S. Shanmuga Kumar, M.D., R.T.**  
Professor & Head,  
Department of Radiotherapy  
Madras Medical College &  
Government General Hospital  
Chennai – 3

**Prof . J. MOHANASUNDARAM, M.D.,**  
**Dean,**  
Madras Medical College,  
Government General Hospital,  
Chennai – 600 023

## **DECLARATION**

I solemnly declare that the dissertation entitled **“DOSIMETRIC EVALUATION OF BLADDER AND RECTAL RADIATION DOSE IN CARCINOMA CERVIX PATIENTS USING ORTHOGONAL RADIOGRAPHS AND CT PLANNING IN HDR BRACHYTHERAPY”** is done by me at Department of Radiotherapy, Govt Arignar Anna Memorial Cancer and Research Institute, Kancheepuram and Madras Medical College, Chennai-3 during June 2010 to August 2010 under the guidance and supervision of Prof. S. Shanmuga Kumar, M.D., to be submitted to The Tamilnadu Dr M.G.R Medical University towards the partial fulfillment of requirements for the award of M.D DEGREE IN RADIO THERAPY BRANCH-IX.

Place:

Date:

**Dr. S. MADHUMATHI**  
M.D. RADIO THERAPY  
Department of Radiotherapy,  
Madras Medical College,  
Chennai.

## **ACKNOWLEDGEMENT**

I express my profound gratitude to **Dr. J. Mohanasundaram, M.D.**, Dean, Madras Medical College and Research, Institute of Government General Hospital, Chennai who with his vast knowledge and experience has been a great source of inspiration.

I express my heartfelt gratitude to **Dr. Veni, M.D.O.G.**, Medical Superintendent, Madras Medical College, Government General Hospital, Chennai for her timely help whenever approached.

I am extremely thankful to **Prof. Dr. Vanitha, M.D.R.D.**, Director, Bernard Institute of Radiology and oncology, Madras Medical College, for the inspiration and encouragement she gave throughout the study.

I express my heartfelt gratitude to **Dr. M. Balu David, M.D.R.T.** Director, Regional Cancer Centre, Kancheepuram for enabling me to utilize the facilities of this institution for conducting this study and for his advice and guidance in making this work complete.

I am extremely grateful to **Prof. S. Shanmuga Kumar M.D.R.T.**, Professor and Head, Department of Radiotherapy, Government General Hospital Chennai for having devised the study, for his encouragement

and guidance throughout the study and the prompt help rendered whenever approached.

I am extremely thankful to **Prof. P. Balasubramaniam, M.D.R.T.**, Department of Radiotherapy, Government General Hospital who helped me with his timely advise and encouragement during this study.

I express my deep gratitude to **Prof. Dr. P. Kaliappan**, Professor of Radiology Physics R.C.C. Kancheepuram, **Mrs. B. Gowri**, Assistant Professor (Radiology Physics) for their inspiration, encouragement and guidance throughout the study and the prompt help rendered whenever approached, for their comments and guidance to complete the study.

I am extremely thankful to Professors **Dr. K. Bhaskaran, M.D.R.T., D.M. (Onco), Dr. S. Kalaivanan, M.D.R.T., Dr. V.R. Venkatagiri, M.D.R.T., Dr. Chitra Chandran, M.D.R.T.**, for helping me with their guidance and help during this study.

I am extremely thankful to Assistant Professors of Radiotherapy **Dr. N.V. Kalaiyarasi, M.D.R.T., D.CH., Dr. B. Ramkumar, M.D.R.T., D.M., Dr. R. Giridharan, M.D.R.T., D.M.R.D., DR. B. Antoinette Mary Nithya, M.D.R.T., D.CH., and Dr. K. Bhaskar, M.D.R.T., DR. P. Rajkumar, D.M.R.T., DR. P. Janarthinakani M.D.R.T.**, for

guiding me with their time, corrections and prompt help rendered whenever approached.

I am also indebted to **Dr. K. Thayalan**, Professor of Radiology Physics and Assistant Professors of Radiology Physics, **Dr. S. Sakthivel**, **Mr. M. Thirumavalavan M.Sc.**, **Mrs. A. Kopperun Devi** for giving me their valuable time and help

I also thank all the postgraduate students for their cooperation which enormously helped me in the study.

Last but not the least I wish to acknowledge the support of my family members and the co-operation of my patients and the blessings of the Almighty without which this work would have been highly impossible.

# CONTENTS

<b>S.NO.</b>	<b>PARTICULARS</b>	<b>PAGE</b>
1.	INTRODUCTION	01
2.	REVIEW OF LITERATURE	04
3.	AIM OF THE STUDY	42
4.	MATERIALS AND METHODS	43
5.	RESULTS AND ANALYSIS	52
6.	DISCUSSION	56
7.	CONCLUSION	62
8.	BIBLIOGRAPHY	63
9.	ANNEXURES	
	I. CONSENT FORM	
	II. ETHICAL COMMITTEE APPROVAL	
	II. ABBREVIATIONS	

## INTRODUCTION

Carcinoma of the uterine cervix is the second most common cancer among global women and the first most common cancer in Indian women. The main stay of treatment in locally advanced inoperable carcinoma Cervix is combination of external beam radiotherapy (EBRT) and intracavitary brachytherapy ICBT. Brachytherapy forms an integral part and cornerstone of radiation therapy for both the local control rates and toxicities.

Intracavitary brachytherapy has a high therapeutic index by delivering a high dose to the primary cervical lesion and lower dosed to critical structures namely, bladder, rectum resulting in increased local control and survival without increase in toxicity. However, the dose deliver to critical structures are difficult to quantify accurately.

In present Indian Scenario dosimetry of ICBT is carried out using orthogonal radiographs where point doses to critical structures are calculated according to the ICRU 38<sup>(1a)</sup> recommendations. This traditional methods have yielded high control rates of tumor and acceptable complications of normal tissue. But the point doses may not represent the dose received by the volume of the organs. It has been reported that the ICRU point doses do underestimate doses received by the rectum and



bladder.<sup>(4-7)</sup> The ratio of maximum dose to the rectum and bladder from the CT planning to that obtained from radiograph based planning has a wide range.<sup>(4-6)</sup>

**STATE OF ART** - Over the previous two decades, with the advent of better imaging modalities (USG, CT, MRI, PET scan) Radiation technology and its successful implementation in external beam radiation therapy (3D CRT, IMZRT, IGRT etc) is a success story today. However, implementation of these advances in brachytherapy has been rather sluggish. Published data on 3D Image based brachytherapy in cervical cancers from India is sparse but it does not preclude its use.

In developing countries including India, locally advanced cervical cancer being a major problem - appropriate, adequate and quality treatment to all patients is the key to success. In India, there has been a rapid improvement in radiation facilities like CT scanner / simulators for RT planning in government sectors. There is an urgent need to generate robust data on CT, MRI-3D image based brachytherapy planning and suitable evidence through clinical studies to resolve the issues.

In an attempt to achieve a better understanding of the treatments, **we compared two treatment planning methods based on orthogonal radiographs and CT Plan.** The comparison was based on point doses

defined by the orthogonal X-rays and dose volume histograms (DVHs) from 3D planning (CT Plan).

I hope the study will give us accurate understanding of the dose received by dose limiting structures like bladder and rectum. It may contribute in improving the therapeutic index both in terms of treatment outcome and reducing the complications.

## REVIEW OF LITERATURE

### EPIDEMIOLOGY

#### INCIDENCE

There is a wide geographical variation in incidence of cancer cervix. The highest incidence rates are reported from Asia, South America and Africa. In India cancer cervix is the commonest malignancy among women with an incidence of over 100,000 new cases annually. It constitutes 20 - 50% of all cancers detected in our women. The AAR of cancer cervix among the various cancer registries of the country ranges from 19-44 per 100,000 women (mean 31.4 per 100,000 women.) According to MMTR 2007 (Madras Metropolitan Tumor Registry) among 2632 women cancer patients 380 were CA cervix patients. The incidence rate in 2007 was 16.4 per lacks. The peak incidence of cervical cancer occurred between 55 to 59 years of age. A significantly decreasing trend in incidence of cervical cancer was forth coming during 1988-2008 with an average annual change of 2%.

Most of the women belong to lower socioeconomic stratum.

The predisposing factors include

#### **1. Female sexual behavior**

- Sexual intercourse - This is the major prerequisite for the development of cancer cervix.

- Age at first coitus - Women who start their sexual life at an early age particularly before 18 years are at higher risk (1.4 to 1.9 times increased risk) of developing cancer cervix.
- Multiple sexual partners - Cancer cervix patients usually give a history of multiple sexual partners. The risk is doubled for women with 6 sexual partners.
- Parity - Risk factors related to parity include first childbirth at an early age and multiparity.

## **2. Male sexual behavior (high risk male)**

High risk male sexual habits, the presence of which is associated with a higher incidence of cancer cervix in their spouses are

- Sexual promiscuity: >3 extra marital partners
- History of sexually transmitted disease
- History of cancer penis (increases risk of cancer cervix in wife by 3 - 6 times)
- History of cancer cervix in first wife (increases risk of cancer cervix second wife 2 fold)
- Poor penile hygiene, Causative role of cigarette smoking in male and the protective effect of male circumcision are controversial.

### 3. Lower socio-economic group

Women from a lower socio-economic group have a higher incidence (about 3 fold) of cervical malignancy due to early marriage, early onset of sexual life and lack of genital hygiene.

### 4. Viral etiology

- **HPV (Human Papilloma Virus)** - Among various agents, the HPV virus is considered to be the most likely candidate for etiological responsibility. Infection with HPV serotypes 16 & 18 are highly prevalent in CIN-II, III and invasive cancer cervix. HPV exerts its effect by P-53 gene suppression and inhibition of cell mediated immunity.
- **HIV (Human immune deficiency virus)** - Women who are HIV positive have a 10 fold risk of cervical cancer in comparison with matched controls. Prevalence of cancer cervix in HIV positive patients below the age of 50 years is 19%.
- **HSV (Herpes simplex virus)** - There is much data suggesting an association between cancer cervix and HSV but no conclusive proof is available.

**5. Smoking** - Smoking appears to double the risk of developing cervical cancer.

## NATURAL HISTORY

Squamous cell carcinoma of the uterine cervix originates at the squamo columnar junction (transformation zone) of the endocervical canal and portio of the cervix. The lesion is frequently associated with severe cervical dysplasia and carcinoma in situ usually progressing over 10 to 20 years. The malignant process breaks through the basement membrane of the epithelium and invades the cervical stroma. The lesion may eventually manifest as superficial ulceration, exophytic tumor in the exocervix, or extensive infiltration of the endocervix. Later on the tumor may spread to the vaginal fornices or to the paracervical and parametrial tissues with eventual direct invasion of the bladder, rectum or both.

The cervix is richly supplied by lymphatics. The cervix is drained by parametrial, cardinal and uterosacral ligament routes into the following regional lymph nodes: Parametrial, Paracervical, Obturator, Internal iliac (hypogastric), External iliac, Common iliac, Sacral, and Presacral. The lymph nodes involvement depends on the tumor bulk and the depth of penetration. The probability of lymph node metastasis in FIGO stages IA1, IA2, IB, IIB and IIIB is approximately 1%, 5-8%, 15%, 30%, 50% respectively.

Hematogenous spread occurs through the venous plexus and paracervical veins. Most frequently involved sites are lung, paraaortic

lymph nodes, spines (lumbar, thoracic), abdominal cavity, supraclavicular lymph nodes. Distant metastasis is mostly seen in cases of advanced disease and in recurrences.

## **CLINICAL PRESENTATION**

- CIS and early invasive carcinoma can be detected before it becomes symptomatic by cytological smears.
- Frequent and first manifestation of cancer cervix is post coital bleeding which may increase to metrorrhagia or menorrhagia.
- Serosanguineous or yellowish foul-smelling discharge is also noted.
- Fatigue, weakness related to anemia if chronic bleeding occurs.
- Pain in pelvis or hypogastrium due to tumor necrosis or associated pelvic inflammatory disease.
- Lumbosacral pain due to para aortic node involvement.
- Hematuria, rectal bleeding may appear due to bladder or rectal invasion by the tumor.

## **PATHOLOGY**

Over 90% of tumors are squamous cell carcinomas. There are 3 types: large cell keratinizing and non-keratinizing and small cell type. They are sub divided according to the degree of differentiation into well, moderately or poorly differentiated. Verrucous carcinoma is a variant of a

very well differentiated SCC which has a tendency to occur locally but not to metastasize.

Adenocarcinoma arises from the cylindrical mucosa of the endocervix or the mucous secreting endocervical glands. Approximately they form 7-10% of cervical tumors. Mucinous is the most common sub type. Other sub types are endometrioid adenocarcinoma, clear cell adenocarcinoma, adenosquamous carcinoma, adenoid cystic carcinoma, and adenoid basal cell carcinoma.

Small cell carcinoma, neuroendocrine tumors, undifferentiated carcinomas, lymphomas and sarcomas are also reported rarely.

## **SCREENING RECOMMENDATIONS**

The American Cancer Society has recommended that asymptomatic women 20 years of age and older and those younger than 20 years who are sexually active should have Papanicolaou smear annually for 2 consecutive years, if normal at least one every 3 years until the age of 65 years.

The American College Of Obstetricians and Gynecologists strongly recommend that Pap smear should be obtained on an annual basis.

High risk women should undergo annual Pap smear examination.



## **DIAGNOSTIC WORK-UP FOR CERVICAL CANCER GENERAL**

History, Physical examination including bimanual pelvic and rectal examinations.

## **DIAGNOSTIC PROCEDURES**

Cytological smears (Pap smear if no bleeding), Colposcopy, Conization (sub clinical tumor), Punch Biopsies (edge of gross tumor, 4 quadrants), Dilatation and curettage

Cystoscopy and Rectosigmoidoscopy (stages IIB, III, IVA)

## **RADIOGRAPHIC STUDIES STANDARD**

Chest radiography, Intravenous pyelography, Barium enema (stages III and IVA and in earlier stages if symptomatic) Ultrasound abdomen

CT scan abdomen and pelvis or MRI, Lymphangiography, PET scan (optional – if affordable)

## **LABORATORY STUDIES**

Complete blood count, Blood chemistry, Urinalysis

## STAGING

TNM	FIGO	
TX		Primary tumor cannot be assessed
TO		No evidence of primary tumor
TIS	*	Ca in situ
T1	I	Cervical Ca confined to uterus
T1a	IA	Invasive Ca diagnosed only by microscope
T1a1	IA1	Stromal invasion not greater than 3mm the depth and 7mm horizontal spread
T1a2	IA2	Stromal invasion >3.mm and not more than 5 mm with 7mm or less horizontal spread.
T1b	IB	Clinically visible lesions confined to Cervix or microscopic extension > IA
T1b1	IB1	Visible lesion 4cm or less in greater dimension
T1b2	IB2	Visible lesion > 4cm in greatest dimension
T2	II	Tumor invades beyond uterus but not to pelvic wall or lower 1/3 vagina
T2a	IIA IIA1 IIA2	Without parametrial invasion IIA1 clinically visible less than 4 c.m. IIA2 Clinically visible more than 4 cm.
T2b	JIB	With parametrial invasion
T3	III	Tumor extends to pelvic wall or involves lower 1/3 vagina causes hydronephrosis or non functioning kidney
T3a	IIIA	Tumor involves lower 1/3 vagina not extending to pelvic wall
T3b	IIIB	Tumor extending to pelvic walls or causing hydronephrosis or non-functioning kidney
T4	IVA	Tumor invades the mucosa of the bladder or rectum and or extends beyond the true pelvis
N0		No regional lymph nodes metastasis
N1		Regional lymph nodes metastasis
M0		No distant metastasis is found.
M1	IVB	Distant metastasis

\* FIGO staging no longer includes stage 0 (TIS)

## **OVERVIEW OF TREATMENT POLICY IN CANCER CERVIX**

All the three standard modalities of oncology namely radiation, surgery and chemotherapy have stamped their role in the treatment of different stages of the disease.

### **ROLE OF SURGERY IN CANCER CERVIX THERAPY**

The role of radical surgery is limited to pre-invasive and early stages of invasive growth.

### **ROLE OF RADIATION IN THE THERAPY OF CANCER CERVIX**

Right from the time of its discovery nearly a century ago, radiotherapy has been the predominant modality used in the therapy of cancer cervix. Radiation finds a place in the management of all stages of the disease. In early-disease it is an effective curative alternative to surgery. In locally advanced disease it is the primary curative modality. In metastatic disease radiation palliates local and distant, complications. Radiation is delivered as brachytherapy alone, as ICA (intracavitary application) in stage I disease or with ideally sequenced combinations of external beam radiation (EBRT) and brachytherapy in other stages. As the size of the lesion and the proportion of the cervix involved increases, the risk of lymph node involvement also increases and one has to irradiate

the whole pelvis, covering the primary tumor, its local extension within the pelvis and the pelvic lymph nodes in contiguity.

A homogenous dose distribution over such a large volume can be achieved only by teletherapy. The external beam radiation is followed by ICA to achieve the highest local control rate possible and this sequence is also ideal in that the tumor shrinkage caused by the initial EBRT will bring the anatomy to near normal resulting in an optimal and uniform dose distribution from a subsequent ICA. EBRT is delivered before brachytherapy in patients with bulky primary tumors, exophytic bleeding tumors, necrotic or infected tumors and tumors with parametrial involvement.

### **PRINCIPLE OF EBRT**

EBRT aims at producing a homogenous dose to the target volume which includes the primary tumor (uterus with cervix), paracervical and parametrial tissue, vagina if involved and regional lymph nodes. EBRT can be delivered by conventional fractionation or by hyperfractionated radiotherapy techniques.

### **PRINCIPLE OF ICA**

ICA delivers a very high dose to the central tumor volume including the cervix and adjacent tissues with maximum tumor control

without crossing the tolerance of surrounding normal tissue. This is possible because the normal uterus and vaginal vault are relatively radio-resistant and tolerate relatively high doses of radiation and there is a rapid fall of dose at a distance from the cervix protecting the rectum, bladder and small bowel.

Intracavitary brachytherapy can be delivered by low dose rate (LDR), moderate dose rate (MDR) and high dose rate (HDR) dose delivery systems. The dose rate of LDR is 0.4- 2Gy/ hr., MDR is 2-12 Gy/hr. and HDR is > 12 Gy/hr.

As many studies have demonstrated comparable local control, survival and morbidity HDR-ICA has been widely incorporated as a component in the treatment of cancer cervix.

## **THE AMERICAN BRACHYTHERAPY SOCIETY DOSE**

### **RECOMMENDATIONS<sup>28</sup>**

The ABS recognizes that the whole pelvic EBRT dose varies from institution to institution. The HDR fraction size and number depends on the EBRT dose. The ABS recommends keeping the total treatment duration to less than 8 weeks so it is recommended to interdigitate HDR applications during EBRT (but EBRT is not given on the day of HDR). When EBRT and HDR brachytherapy are combined, the goals are to treat

Point A to an LDR equivalent of 80-85 Gy for early stage disease and 85-90 Gy for advanced stage. Early disease is defined as nonbulky stage I/II, less than 4cm diameter; advanced stage is defined as greater than 4 cm or stage III B. The pelvic sidewall dose recommendations are 50-55 Gy for smaller lesions and 55-60 Gy for larger lesions.

### **Suggested doses of EBRT and HDR brachytherapy in treating late cervical cancer**

<b>EBRT (Gy) @ 1.8 Gy/#</b>	<b>No. of HDR fractions</b>	<b>HDR dose/fraction</b>
45	5	6.5
45	6	5.8
50.4	4	7.0
50.4	5	6.0
50.4	6	5.3

### **SOURCES FOR HDR INTRACAVITARY BRACHYTHERAPY**

A radionuclide with high specific activity (activity per unit mass; Ci/g) is needed so that treatment dose rates of at least 12 Gy/hr can be achieved without sacrificing the level of miniaturization needed to support intracavitary and interstitial brachytherapy. A source no larger than 1mm in diameter by 4mm long with an exposure rate of at least 1R/sec at 1cm is required. The exposure rate achieved by a small source

depends on the chemical form (i.e. relative mass of non radioactive atoms) of the source, its density, exposure rate constant of the radionuclide and photon self absorption.

## **SOURCES**

The need for high specific activity sources limits the number of radio isotopes suitable for HDR remote after loaders. Most HDR units use Iridium-192 ( $^{192}\text{Ir}$ ) or cobalt 60 ( $^{60}\text{Co}$ ).  $^{192}\text{Ir}$  offer smaller source sizes but sources must be changed frequently. Most centers exchange their  $^{192}\text{Ir}$  sources every 3 or 4 months (half life 73.8 days) whereas a similar decay fraction for  $^{60}\text{Co}$  takes 5-8 years (half life 5.26 years).  $^{60}\text{Co}$  is used as an intracavitary HDR sources in the form of small spherical pellets emits two high energetic  $\gamma$  rays (1.17 & 1.34 MeV). The smaller  $^{192}\text{Ir}$  sources permit access to more body sites via interstitial or intraluminal applications.  $^{60}\text{Co}$  and Cesium- 137( $^{137}\text{Cs}$ ) sources are suitable only for intracavitary and some intraluminal treatment such as for esophagus.

Based solely on specific activity considerations  $^{192}\text{Ir}$  is the optimal choice for HDR brachytherapy and is the widely used radionuclide for this application.

## **HIGH DOSE RATE- Iridium-192**

Iridium-192 (alloy of 30% Ir and 70% Pt) sources are fabricated in the form of thin flexible wires which can be cut to desired lengths. Nylon ribbons containing iridium seeds 3 mm long and 0.5 mm in diameter, spaced with their centers 1 cm apart, are also commonly used. Both the wires and the seed ribbons are quite suitable for the after loading technique.  $^{192}\text{Ir}$  has a complicated  $\gamma$  ray spectrum with an average energy of 0.38 MeV (0.136-1.06MeV) Because of the lower energy, these sources requires less shielding for personnel protection. The Exposure rate constant ( $\tau$ ) for  $^{192}\text{Ir}$  is  $4.69 \text{ Rcm}^2 \text{ h}^{-1} \text{ mCi}^{-1}$ .

## **REMOTE AFTERLOADER**

Remotely controlled after loading devices are now available that eliminate the direct handling of the radioactive sources. A HDR remote after loading unit contains a single source of high activity (~10 Ci or 370 GBq).

The  $^{192}\text{Ir}$  source used in HDR is a small line source welded to the end of a flexible drive cable. The cable with the source attached at the end is also called source wire. The after loader drives the source to programmed location in the applicator (dwell positions) and holds it in place there for programmed intervals (dwell times). The term stepping



source is applied to the design. The possibility of programming the dwell position and times individually permits more control over the dose distributions and is the prerequisite for many of the optimization techniques. The dimensions of the source vary between 0.3 to 0.6 mm in diameter and 3.5 to 10 mm in length, depending on the HDR model. The source wire, when not extended, is stored in a shielded safe of the HDR unit. In compliance with the NRC regulations, the leakage radiation levels outside the unit do not exceed 1 mR/h at a distance of 10 cm from the nearest accessible surface surrounding the safe with the source in the shielded position.

The HDR unit is equipped with several channels and an indexer system to direct the source to each channel. Applicators or catheters implanted in the patient are connected to the channels by catheters called transfer tubes or transfer guides. Before the active source wire is extended for treatment, a dummy wire is extended to verify that the path is clear of any obstruction.

The source wire (or dummy wire) can be advanced or retracted through individual channels, transfer tubes and applicators by a remote computer controlled drive mechanism consisting of stepper motors. The positioning of the source at the programmed dwell positions in the applicators is accomplished in precise increments by the stepper motors.

The positioning accuracy of the source is specified at  $\pm 1$  mm. The dose control precision is provided by a 0.1-second dwell time resolution.

Some of the commercially available remote afterloading systems include the Curietron, the micro-Selectron, the Gamma Med, Omnitron 2000 and Buchler unit.

## **HIGH DOSE RATE APPLICATORS**

Brachytherapy applicators used for low dose rate implants can also be used for HDR. For example, some of the most commonly used applicators, for a variety of HDR applications, are:

### **Fletcher-Suit or Fletcher-Suit-Delco's**

These applicators are used for the treatment of gynecological malignancies of the uterus, cervix and pelvic side walls. The applicator set typically consists of three rigid intrauterine tandems, with curvature of 15-, 30-, and 45-degree angles, and a pair of ovoids or colpostats with shields in place to reduce dose to rectum and bladder. The tandem and the ovoids (or the colpostats) are made of stainless steel and then secured to hollow handles to permit afterloading of the sources. The colpostats in the Fletcher-Suit applicator are partially shielded at the top and the bottom to provide some protection to bladder and rectum. However, dosimetrically it is difficult to demonstrate the extent of protection actually provided by these shields.

## **DOSE SPECIFICATION: CANCER OF THE CERVIX**

No single system has been devised that can meet all the criteria of dose specification, three systems are described that are most commonly used in many forms and combinations.

### **A. Milligram-Hours**

One of the oldest systems of dose specification for the brachytherapy treatment of cervix is the milligram-hours, that is, the product of total source strength and the implant duration. It lacks the information on source arrangement, position of tandem relative to the ovoids, packing of the applicators, tumor size, and patient anatomy, with large uncertainties in the dose distribution from patient to patient. Although the milligram-hours are an important treatment parameter, it cannot be made the sole basis of dose-response curve.

### **B. The Manchester System**<sup>31,32</sup>

The Manchester system is one of the oldest and the most extensively used systems in the world. It is characterized by doses to four points: point A, point B, a bladder point, and a rectum point. The duration of the implant is based on the dose rate calculated at point A, although the dose at the other points is taken into consideration in evaluating a treatment plan. With the availability of the treatment planning computers,

most users of the Manchester system examine the isodose distributions in the frontal and sagittal planes in addition to obtaining dose at the four designated points. Point A still remains the point of dose prescription.

Point A was originally defined as 2 cm superior to the lateral vaginal fornix and 2 cm lateral to the cervical canal. Later, it was redefined to be 2 cm superior to the external cervical os (or cervical end of the tandem), and 2 cm lateral to the cervical canal. Point B is defined 3 cm lateral to point A.

Ideally, a point A represents the location where the uterine vessels cross the ureter. It is believed that the tolerance of these structures is the main limiting factor in the irradiation of the uterine cervix. Point B represents obturator node.

Original definition of points A and B, according to the Manchester system.

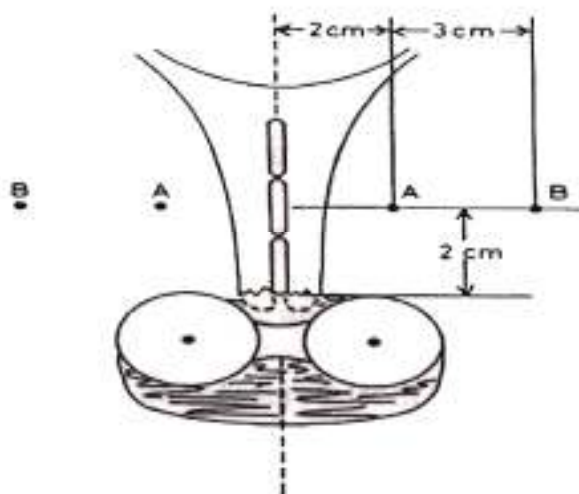

### **C. The International Commission on Radiation Units and Measurements System<sup>3</sup>**

The ICRU has recommended a system of dose specification that relates the dose distribution to the target volume, instead of the dose to a specific point. The dose is prescribed as the value of an isodose surface that just surrounds the target volume.

#### **DATA REQUIRED FOR REPORTING INTRACAVITARY THERAPY IN GYNECOLOGY (ICRU)<sup>3</sup>**

- 1. Description of the Technique:** Minimum information should include the applicator type, source type and loading and orthogonal radiographs of the application.
- 2. Total Reference Air Kerma.** By this parameter, is meant the total air kerma strength of sources times the implant duration. This is similar to the total milligram-hours of radium or total mg-Ra eq-h except that the sources are calibrated in units of air kerma strength, that is,  $\mu\text{Gy m}^2 \text{ h}^{-1}$ .
- 3. Reference Volume.** The reference volume is the volume of the isodose surface that just surrounds the target volume. The prescription isodose value of 60 Gy includes the dose contribution

from the external beam. The reference volume for the intracavitary part of the treatment should be identified and its dimensions recorded. The figure below shows how the height ( $d_h$ ), width ( $d_w$ ), and thickness ( $d_t$ ) of the pear-shaped reference volume can be measured from the oblique frontal and oblique sagittal planes. The reference volume is approximated by ( $d_h \times d_w \times d_t$ ).

### Plane a

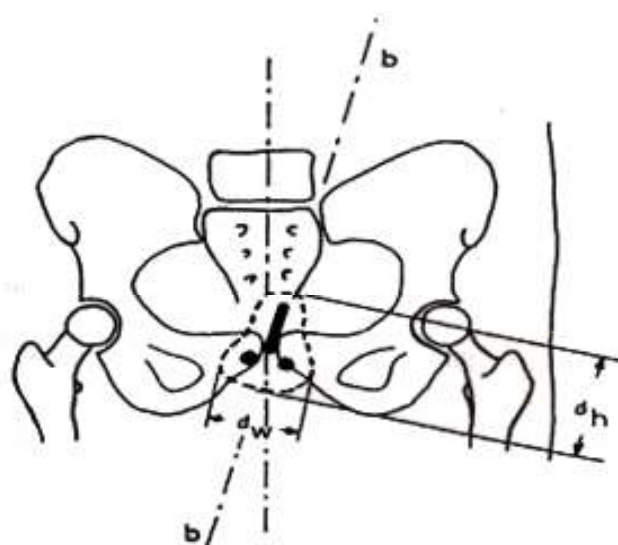

### Plane b

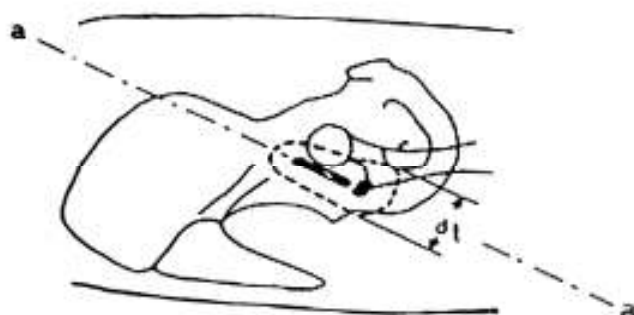

Determination of the reference isodose surface dimensions.  $D_w$ , width;  $d_h$ , height;  $d_t$ , thickness.<sup>3</sup>

## 1. Absorbed Dose at Reference Points

- Bladder Point:** The bladder point is localized by using a Foley catheter, with the balloon filled with 7 ml of a contrast material. On the frontal radiograph, the bladder point is marked at the center of the balloon; on the lateral radiograph, the bladder point is obtained on a line drawn antero posteriorly through the center of the balloon, at the posterior surface.

**Rectal Point:** The rectal point is identified on the frontal radiograph at the midpoint of the ovoid sources (or at the lower end of the intrauterine source). On the lateral radiograph, the rectal point is located on a line drawn from the middle of the ovoid sources, 5 mm behind the posterior vaginal wall. The posterior vaginal wall may be visualized by using radiopaque gauze for the vaginal packing. In our institute rectal catheter is inserted into rectal lumen to identify rectal reference point.

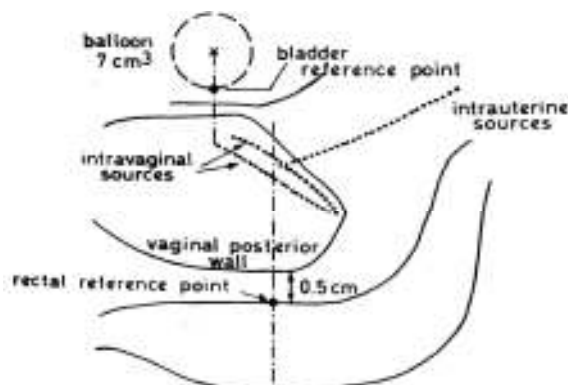

Localization of bladder and rectum points-ICRU-38<sup>3</sup>

- **Pelvic Wall Points:** On the anteroposterior radiograph, the pelvic wall points are located at the intersection of a horizontal tangent to superior aspect of the acetabulum and a vertical line touching the medial aspect of the acetabulum. On the lateral view, these points are marked as the highest middistance points of the right and left acetabulums.
- 5. Time dose pattern:** The duration and time sequence of the implant relative to the external beam treatment should be recorded.

In summary, the ICRU system of dose specification is probably the best that can be achieved at this time. Its greatest weakness however, is in the determination of reference volume. Further progress needs to be made in the determination and delineation of the target volume so that the cervix dose can be specified by the minimum target dose.

## **CALCULATION OF DOSE DISTRIBUTION**

A modular approach has been proposed by the AAPM Task Group 43 in which the effects of several physical factors on dose rate distribution are considered.

Because anisotropy is not as serious a problem for  $^{192}\text{Ir}$  seeds as it is for  $^{125}\text{I}$  seeds, indium seeds may be treated as point sources in dose calculation formalism. For a point source,

$$D(r) = A S_k (g(r)/r^2) \Phi_{an}$$



Where  $A$  - dose rate constant,  $S_k$  - air kerma strength,  $g(r)$  - radial dose function,  $r$  - radial distance in Cm.  $\Phi_{an}$  - the average anisotropy factor. It is defined as the ratio of  $4\pi$  averaged dose rate at a given radial distance divided-by the dose rate at the same distance along the transverse axis.  $\Phi_{an}$  for  $^{192}\text{Ir}$  seeds may be equated to unity.

## **DOSIMETRIC CHARACTERISTICS OF BRACHYTHERAPY SOURCES**

In general, four factors influence the single-source dose distribution for photon-emitting sources: (1) distance (inverse-square law); (2) absorption and scattering in the source core and encapsulation; (3) photon attenuation and (4) scattering in the surrounding medium.

Each voxel of radioactive core material can be assumed to be an isotropic point source. Because of the straight-line emission of photons in all directions, photon intensity or fluence,  $\Phi(r)$ , at any point is proportional to the inverse square of its distance,  $r$ :

$$\Phi(r) = \frac{\text{no. incident photons / unit area irradiated} = \text{no. photons emitted}}{4\pi r^2}$$

$\alpha$  Dose (r)  $\alpha$  Exposure (r) assuming that attenuation and scattering can be neglected.

To illustrate the derivation of inverse-square law, consider the source is surrounded by vacuum and placed at the centre of two concentric spherical surfaces of radii  $r_1$  and  $r_2$ . By definition, an isotropic point source has no extension and radiates photons with equal likelihood in all directions in straight-line paths. As a result of this purely geometric effect, the absorbed doses  $D(r_1)$  and  $D(r_2)$  at the two distances  $r_1$  and  $r_2$  are related by:

$$D(r_1)/D(r_2) = \Phi(r_1)/\Phi(r_2) = (r_2/r_1)^2$$

This fundamental law applies exactly to each point of the radioactive core of the source. However, above equation will not accurately describe the "collective" dose fall-off arising from the combined action of the point sources distributed throughout the core, unless both  $r_1$  and  $r_2$  are large relative to the active source dimensions. Of the four factors influencing the dose distribution inverse-square law is the most dominant. For a pure isotropic point source, dose will decrease by a factor of 100 between the distances of 0.5 and 5 cm. The influence of the remaining factors over the same distance range rarely exceeds a factor of 2 or 3. Consequently, most of the clinical characteristics of implants can be accounted for by applying inverse-square law to each point like element of radioactivity within the implant.

The normal tolerance doses of various organs included in the treatment field are as follows -

Uterus with cervix	:	200 - 300Gy
Vagina	:	160-200Gy
Bladder	:	80Gy
Rectum	:	70Gy

The tolerance of the rectum and bladder are the critical dose limiting points in the radiation of cancer cervix.

## **RT REACTIONS**

**EARLY REACTIONS:** Include radiation proctitis, cystitis and ileitis. Usually they are mild and transient. Skin reactions vary from erythema, dry desquamation to moist desquamation and ulceration. Skin morbidity can be totally avoided by proper radio therapeutic techniques.

## **LATE BLADDER -RTOG TOXICITY GRADING**

Grade 0	None
Grade 1	Slight epithelial atrophy, Minor telangiectasia, Microscopic hematuria
Grade 2	Moderate frequency, Moderate telangiectasia, Intermittent macroscopic hematuria
Grade 3	Severe frequency & dysuria, Severe generalized telangiectasia (often with

	petechiae), Frequent hematuria, Reduction in bladder capacity (<150 cc)
Grade 4	Necrosis, contracted bladder (<100 cc), Severe hemorrhagic cystitis

### **LATE RECTAL-RTOG TOXICITY GRADING**

Grade 0	None
Grade 1	Mild diarrhea, mild cramping, bowel movement < 5 times daily. Slight rectal discharge or bleeding
Grade 2	Moderate diarrhea, colic , bowel movement > 5 times daily. Excessive rectal mucous discharge or intermittent bleeding
Grade 3	Obstruction or bleeding requiring surgery
Grade 4	Necrosis, perforation ,Fistula

### **FACTORS INFLUENCING LATE BLADDER AND RECTAL COMPLICATIONS**

There are many factors which influence bladder and rectal complications-Patient related factors and Treatment related factors.

#### **I. PATIENT RELATED FACTORS**

##### **1. AGE OF THE PATIENT AND STAGE OF THE DISEASE**

Increased complication risk in older age group may be partially related to accompanying physiological changes and frequent medical conditions such as diabetes, hypertension and atherosclerosis.<sup>17</sup>

Additional risk, when treating with intracavitary brachytherapy, is created by age-related anatomical changes.

**Elzbieta Senkus-Konefka et al<sup>26</sup>** in their study observed that increasing patient age and disease stage resulted in the decreased frequency of use of large ovoids (both  $p < 0.0001$ ) and of long tandems (age :  $p = 0.037$ , stage:  $p = 0.004$ ). As a result, higher doses to bladder (age:  $p = 0.0001$ , stage:  $p = 0.017$ ) and rectum (age:  $p = 0.037$ , stage:  $p = 0.011$ ).

## **2. ASSOCIATED CO-MORBIDITIES**

- **Willett et al<sup>38</sup>** reported on 28 patients with Irritable Bowel Disease (Crohn's disease, Ulcerative colitis) treated by conventional irradiation technique had 73%- 5 year actuarial rate of late toxicity. Patients treated by specialized techniques (to minimize large and small bowel radiation dose) had 23%- 5 year actuarial rate of late toxicity.
- **Roeske et al<sup>29</sup>** in his study had shown that Diabetes ( $p = 0.03$ ) is a significant factor affecting late rectal sequelae.

## **II TREATMENT RELATED FACTORS:**

Major factors affecting the late complications in HDR -ICBT are treatment related factors.

### **1. BIOLOGICAL EFFECTIVE DOSE (BED)**

It plays an important role in late bladder and rectal complications.

- **Ferrigno et al<sup>27</sup>** in his study observed that patients treated with cumulative BED at rectal point  $> 110 \text{ Gy}_3$  and at bladder point  $> 125 \text{ Gy}_3$  had a higher but not statistically significant 5-year actuarial rate of complications at these organs (18% vs. 12%,  $p=0.49$  and 17% vs. 9%,  $P=0.20$ ).
- **Brenda Clark et al** in her study found out if the BED is above 125  $\text{Gy}_3$  the rectal complications rise sharply.

## 2. HDR DOSE PER FRACTION

- **Orton et al<sup>33</sup>** in his meta-analysis has noted that fractionation of the HDR treatments significantly influenced toxicity: morbidity rates were significantly lower for Point A doses/ fraction  $< 7 \text{ Gy}$  compared with  $> 7 \text{ Gy}$  for both severe injuries (1.28% vs. 3.44%,  $p < 0.001$ ) and moderate plus severe (7.58% vs. 10.51%,  $p < 0.001$ ).
- **Wang et al<sup>30</sup>** in his prospective- study has shown that the complication rates for 2 groups (Group - 1 EBRT + 7.2 Gy / fraction to Point A for 3 fractions of HDR -4CBT, Group-2 EBRT + 4.8 Gy/ fraction to Point A for 5 fractions of HDR-ICBT).

The actuarial proctitis rate for groups land 2 was 49.7% and 32.7% at 5-years and 50.5% and 32.7% at 10 years, respectively ( $p < 0.001$ ). Most

of the decrease in the rate of proctitis was a result of a decrease in the incidence of low grade proctitis (38% vs.22%) while high grade complications remained unchanged, 8% vs. 7%. The actuarial cystitis rate for groups land 2 was 14.3%vs. 11.4% at 5 years and 24.1% vs. 15% at 10 years, respectively (p=0.134).

### **3. EBRT TOTAL DOSE**

- **Montana and Fowler<sup>37</sup>** in their study noted that the incidence of proctitis did increase with increasing dose of EBRT to whole pelvis. It ranged from 3% for dose < 20 Gy to whole pelvis to 14% with doses higher than 40 Gy (p=0.02).
- **ABS<sup>27</sup>** recommends whole pelvis RT of < 46 Gy when EBRT is combined with intracavitary brachytherapy.

### **4. EBRT TECHNIQUES**

- Yamazaki et al<sup>37</sup> observed that 4 field whole pelvis RT (50 Gy) had significant lower rate of bowel complications than 2 parallel opposing fields (2.9% vs.17.5%, p< 0.05).

### **5. TOTAL RECTAL AND BLADDER DOSE**

- **Montana GS , Fowler WC<sup>37</sup>** in their study showed that risk of proctitis increased as a function of rectal dose ranging from 2% for

patients receiving  $\leq 50$ Gy to rectum to 18% for patients receiving  $>80$ Gy.

- Grade 1 proctitis =  $6810 \pm 906$  cGy
- Grade 3 proctitis =  $6997 \pm 1137$  cGy,  $p=0.003$

Also dose response relationship was found between the rectal dose and severity of the complication

The incidence of cystitis ranged from 3% for  $< 50$  Gy to the bladder to 12% for  $>80$  Gy or higher doses.

- **Perez et al<sup>1b</sup>** in his retrospective review of 1456 patients with carcinoma cervix treated with definitive irradiation (EBRT + 2 LDR insertions) reported that in bladder doses below 80Gy correlated with  $<$  than 3% incidence of morbidity and 5% with higher doses. ( $p=0.31$ ). In recto sigmoid, the incidence of significant morbidity was  $<$  than 4% with doses below 75 Gy and increased to 9% with higher doses. Multivariate analysis showed that dose to rectal point and bladder point was the only factor influencing recto sigmoid and bladder sequelae respectively.

## 7. POINT A DOSE

- **Perez et al<sup>1b</sup>** in the same study showed that when the ratio of dose to the bladder or rectum in relation to point A was 0.8 or less, the



incidence of rectal morbidity was 2.5% vs. 7.3% with higher ratios ( $p \leq 0.01$ ); bladder morbidity was 2.3% vs. 5.8% respectively ( $p = 0.02$ ).

- **Roeske JC et al<sup>29</sup>** in his study noted that Point A dose ( $p = 0.04$ ) and conventional EBRT dose ( $p = 0.03$ ) were the most significant factors determining the late rectal sequelae.
- **The ABS<sup>28</sup>** has given recommendations to keep the dose to the nominal rectal and bladder points below 80% of the dose to Point A with HDR treatment protocols.

## **WORLDWIDE SCENARIO**

Various imaging modalities like ultrasound, CT, MRI and PET scans etc have been explored in brachytherapy today. CT based Brachytherapy planning is more or less standard of care for most of the sites in the West. The advantages of CT based planning are accurate catheter reconstruction, better delineation of organ-at-risks (OAR's) and documentation of dose volume parameters (DVH Parameters). However, the major disadvantage of inaccurate target volume delineation has paved way for MR based brachytherapy. MR imaging is becoming increasingly popular imaging modality for diagnosis and treatment planning for EBRT and BT. GYN GEC ESTRO Brachytherapy working group has

recommended contouring guidelines, concepts and terms in 3D Image Based treatment planning in cervical cancer brachytherapy. Recent reports from Vienna, Paris, Aarhus, Leuven etc. confirm the safety, feasibility and definite advantages of MR image based brachytherapy planning. Also there are reports from Vienna and Paris groups about the clinical outcome and late toxicities supporting the use of MR based brachytherapy with dose volume adaptation and escalation in locally advanced cervical cancers.

## **INDIAN SCENARIO**

With advent of better imaging modalities, radiation technology and its successful implementation in external beam radiation therapy (3D CRT, IMRT, IGRT etc.,) is a success story today. However, implementation of these advances in brachytherapy has been rather sluggish. There are many ways to reduce the bladder and rectal complications. High precision radiotherapy techniques like 3DCRT, IMRT, IGRT, DART are evolving to deliver high radiation dose to the tumor and sparing the critical normal structures. The study of **Dr Umesh Mahantshetty et al**<sup>36</sup> (TMH) has stated that there is an urgent need to generate robust data on CT/MR 3D-Image Based Brachytherapy to resolve the issue. In developing countries including India, locally advanced cervical cancer being a major problem, appropriate, adequate and quality treatment to all patients is the key to

success. In india, there has been a rapid rise in corporate and steady improvement in radiation facilities in government sectors. Most of the facilities have CT scanners / simulators for RT Planning. An attempt should be done by all high volume centres to incorporate some form of image based approach both for teletherapy and brachytherapy for cervical cancers from India is sparse but it does not preclude its use. There is an urgent to generate robust data on CT or MR 3D Image Based Brachytherapy Planning and suitable evidence through clinical studies to resolve the issues further in optimizing treatment for cervical cancers.

## **REFERENCE STUDIES**

### **STUDY 1**

**Comparison of conventional and CT-based planning for intracavitary brachytherapy for cervical cancer: target volume coverage and organs at risk doses Gungor Arslan et al <sup>(34)</sup>**

In this study dosimetric data for 62 conventional and CT based ICBT plan of stage IB2, stage IIIB were analysed.

The comparison was based on point doses defined by the ICRU and dose volume histograms (DVHs) from 3D planning.

## **PROCEDURE**

The treatment consists of EBRT 50.4 Gy (1.8 Gy/fr, daily, Monday through Friday) Brachytherapy was performed with a remote afterloading HDR unit with a radioactive Iridium 192 sources. The median amount of time between the completion of EBRT and the first brachytherapy application was 2 days (range 1-5 days). The planned dose per fraction was 7 Gy prescribed to point A, given in 4 fractions, and the Brachytherapy was delivered twice weekly.

All patients underwent both conventional and 3D planning. CT compatible applicators were used in this study. A comparison of the conventional plan and CT plan was performed using the students t test. p value less than 0.05 were consider statistically significant.

## **RESULT**

This study indicated that 3D maximum bladder and rectum values were 1.51 and 1.66 times greater than the ICRU reference bladder and rectum doses, respectively. ( $p = 0.07$ ). This study demonstrate that CT guided brachytherapy planning is superior to conventional planning in evaluation of organ at risk bladder and rectum.

## **STUDY 2**

### **Comparison between CT and Orthogonal Based Calculation of ICRU Rectal and Bladder Doses During Intracavity Brachytherapy for Cervix Cancer- Are Orthogonal Films now Obsolete?<sup>35</sup>**

In the study of **Alison Cameron et al** 24 patients were analysed all patients had a CT scan of pelvis at 2 mm slice intervals and digitalized A-P and lateral films taken. Standard plans were applied to these images, with the dose defined at point A, using the varian brachytherapy planning system (Brach vision). ICRU-38 Rectal and bladder points were identified and doses at these points recorded. The paired t-test was used to determine if there was statistically significant difference between the doses calculated in an individual patient using CT or orthogonal imaging.

## **RESULTS**

24 patients were analysed. For the ICRU rectal point the mean dose difference was 4.02 (1.43-6.60;  $p < 0.01$ ) between CT and orthogonal based calculations of dose. Similarly the ICRU bladder point mean dose difference was 3.81 (1.48-15;  $p < 0.01$ ).

The study states that there is a statistically significant difference between ICRU rectal and bladder doses when calculated with CT or orthogonal imaging of about 4%. Approximately 6% of patients receiving

radical radiotherapy of cervix cancer, despite being within dose constraints for ICRU bladder and rectal points, develop serious bowel or bladder toxicity. It is possible that some of this toxicity may be due to the inaccuracy in measurement of the ICRU bladder and rectal point from orthogonal images as documented in this report.

### **STUDY 3**

#### **Dosimetric evaluation of rectum and bladder using image-based CT planning and orthogonal radiographs with ICRU 38 recommendations in intracavitary brachytherapy**

Swamidas V. Jamema, Sherly Saju, Umesh Mahantshetty et al<sup>36</sup>

The purpose is to compare CT based dosimetry with International Commission on radiation Units and Measurements (ICRU 38) bladder and rectum reference points in patients of carcinoma of uterine cervix treated with intracavitary brachytherapy.

### **PROCEDURE**

This study at Tata Memorial Hospital, Mumbai included 22 patients of stage IIB and stage IIIB. All the patients were treated standard dose of external beam radiotherapy followed by ICA-HDR brachytherapy according to their institutional protocol. Stage IIB 7 Gy 5 fractions. Stage IIIB 7 Gy 3 fractions. Orthogonal radiographs and CT images were

acquired and transferred to PLATO planning system, bladder and rectal reference points were identified according to ICRU 38 recommendations. Dosimetry was carried out based on Manchester system. Patient treatment was done using <sup>192</sup>Iridium high dose rate (HDR) remote after loading machine based on the conventional radiograph based dosimetry.

## RESULTS

ICRU rectal and bladder point doses from the radiograph plans were compared with  $D_2$ , dose received by  $2\text{cm}^3$  of the organ receiving maximum dose from CT plan  $V_2$ , volume of organ receiving dose more than the ICRU reference point, was evaluated. The mean volume of rectum and bladder was  $60 (\pm 28) \text{cm}^3$  and  $138 (\pm 41) \text{cm}^3$  respectively. The mean reference volume in radiograph and CT plan was  $105 (\pm 7) \text{cm}^3$  and  $107 (\pm 7) \text{cm}^3$  respectively. It was found that  $6 (\pm 4) \text{cm}^3$  of rectum and  $16 (\pm 10) \text{cm}^3$  of bladder received dose more than the prescription dose  $V_2$  of rectum and bladder was  $7 (\pm 1.7) \text{cm}^3$  and  $20.8 (\pm 6) \text{cm}^3$  respectively. Mean  $D_2$  of rectum and bladder was found to be  $1.11 (\pm 0.2)$  and  $1.56 (\pm 0.6)$  times the mean ICRU reference point respectively. This dosimetry study suggest that comparison of orthogonal X-ray based and CT based HDR ICA planning is feasible. ICRU rectal point dose correlates well with maximum rectal dose, while ICRU bladder point underestimates the maximum bladder dose. In our study

volumetric analysis was not undertaken as it is in this study. Only point based dosimetric analysis was done.

Metal applicator used in the study produce streak artifacts in the CY images which make reconstruction of the applicator difficult which may lead to inaccurate applicator reconstruction. MRI/CT compatible applicators are expensive and not as strong as metal applicators. Which prohibits the use of these expensive applicators in routine clinical practice especially in developing countries. Hence refinement of the existing applicators and development of new cost effective applicators and fast reconstruction methods with delineation of targets and critical structures are required for the implementation of image based brachytherapy in routine clinical practice.



## AIM AND OBJECTIVE OF THE STUDY

To compare bladder and rectal radiation dose between orthogonal based dosimetry and CT based dosimetry.

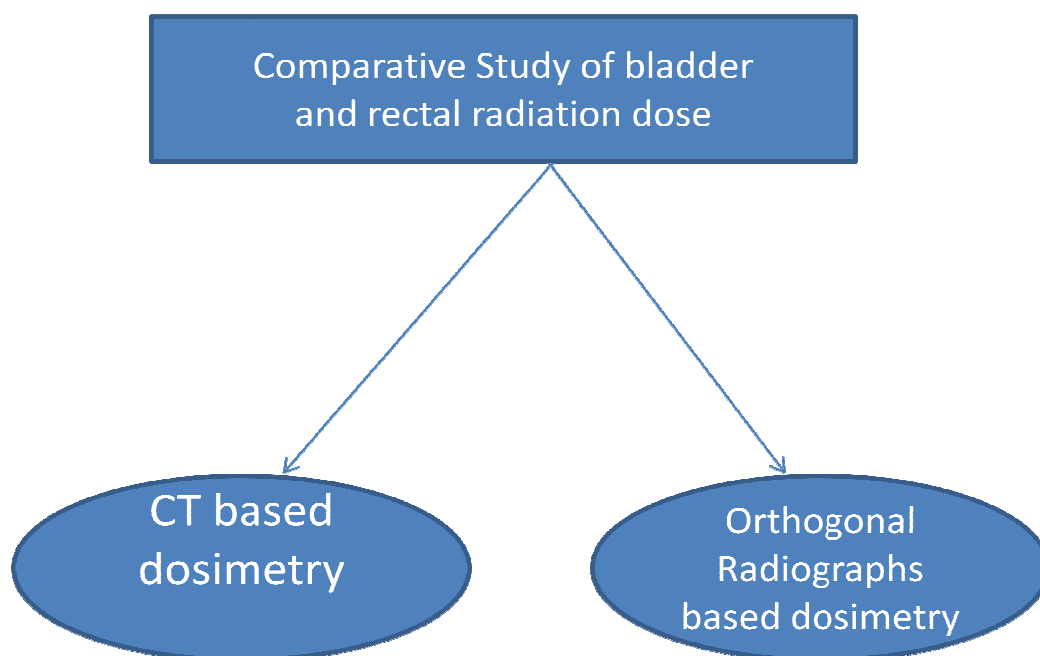

## **MATERIALS AND METHODS**

**STUDY PERIOD** : From June 2010 to August 2010

**STUDY DESIGN** : Comparative descriptive study

**CASE SELECTION** : Biopsy proven squamous cell Carcinoma cervix cases of stage IIB – IIIB who had completed EBRT and slated for HDR brachytherapy.

**NUMBER OF PATIENTS: 30**

### **INCLUSION CRITERIA**

- All eligible biopsy proven squamous cell carcinoma cervix patients, who had completed EBRT and slated for HDR Brachytherapy.
- Stage II B – III B where HDR is contemplated.
- Age: 30 - 60 years.
- Performance Status: ECOG 0-1 histological proof from primary lesion.
- Informed consent to be taken.
- Patient should be fit for anesthesia.

## **EXCLUSION CRITERIA**

- Age > 60 years.
- ECOG more than 2.
- Patients not fit for anesthesia.
- Patients with stage IV disease.
- Histology other than squamous cell carcinoma.
- History of prior radiotherapy / chemotherapy to Ca cervix.

## **PRE-TREATMENT EVALUATION**

- History.
- Physical examination with emphasis on gynaecological examination.
- Biopsy.
- LAB studies (CBE, LFT, RFT, VDRL, and HIV).
- ECG.
- Radiographic studies,
- Chest X-ray.

- USG abdomen and pelvis to assess primary disease local extension, nodal status and visceral metastasis.
- CT Pelvis.
- Cystoscopy.
- Per speculum examination and by passing uterine sound to assess whether the patient is fit for intra cavity application.

### **TREATMENT PROTOCOL**

- Conventional EBRT - 50 Gy in 200c Gy per fraction 5 days a week 25 fraction.

EBRT equipment : Co-60 Phoenix for Teletherapy

Treatment portals : Ap and PA portals daily

### **TREATMENT PLANNING EBRT**

The whole pelvis including the cervix,vagina and parametria with the pelvic and iliac group of nodes was treated.

### **RT PORTAL MARGINS FOR EBRT**

1. Superior: L4-L5 interspace (to include all the iliac and hypogastric nodes).

2. Inferior: If vagina is free - Lower margin of Obturator foramen. If vagina is involved - the entire vagina up to the introitus was included.
3. Lateral: 2 cm.lateral to bony pelvis.

### **SIMULATION AND TREATMENT DELIVERY**

The treatment field was verified with PA simulator films in which the distal extension of the tumor was identified by placing a radio-opaque marker in the vagina. All patients were positioned in the prone position only with full bladder during external RT to exclude a greater extent of the small bowel from the treatment field. The AP portal was treated daily by gantry rotation of 180°.

### **ICA PROTOCOL**

After teletherapy the patients were assessed for intracavitary application. Those found fit were subjected to high dose rate (HDR) Brachytherapy.

### **HDR BRACHYTHERAPY PROTOCOL**

Technique Remote after loading with Iridium-192 source

Machine HDR- micro Selectron

Activity 2- 10 Ci

Intracavitary applicator	Modified Fletcher Suit applicator with tandem 15° and ovoids 30° angulations.
No. of #s	TWO (1# -1 week after EBRT, 2# -1 week after 1#)
Dose delivered to Point A	800cGy /# -2#
Total Dose to point A	86.7Gy (LDR equivalent).
LQED	81 Gy
Total BED to rectum	126Gy <sub>2.5</sub> and bladder 140Gy <sub>2.5</sub>

## **PROCEDURE**

I.V. Sedation with ketamine, patient in lithotomy position the perineum and upper half of the thighs were cleaned and draped. Per vaginal examination was done. Urinary bladder was catheterized and 7ml. of diluted contrast (urograffin 3ml. +distilled water 4ml.) was injected into the Foley balloon. Uterine sound was introduced and uterine length assessed. The cervical stopper was adjusted according to the uterine length and fixed. The tandem was introduced into cervix and ovoids into vaginal formic and secured. Adequate vaginal packing was done in a conventional manner with adequate gauze to displace the bladder and rectum and to secure the applicators in position. Rectal catheter with

radio opaque marker was introduced into the rectum to find out the anterior rectal wall. A tape sling tied to the abdomen externally was used to further secure the apparatus in position.

Patient shifted to simulator room. Orthogonal X-rays AP and lateral were taken.

Subsequently the films were digitized and dose calculations were obtained using Nucletron Plato brachytherapy Treatment Planning System. The dose was prescribed to Point -A.

## **DOSE SPECIFICATIONS**

Point A and Point B were defined according to Manchester system of dose definition. The bladder and rectal reference points defined by ICRU 38 were used to calculate the bladder and rectal point dose before and after inflation. Additional points for rectum were also taken for dose calculations to get a better idea of dose received by rectum.

Four additional rectal points were taken 1 cm above and below the usual rectal reference points.

## **Conventional dosimetry**

- Orthogonal radiographs (anterior-posterior and lateral) were taken on a conventional simulator with radioopaque markers in the

applicators. The cervical stopper is identified in Orthogonal film and used as origin radiographs were reconstructed and the treatment planning was done using PLATO planning system.

- Source positions were loaded according to the standard loading pattern in accordance with the Manchester system. Point A was defined on the radiographs as being 2 cm superior to the cervical stopper (flange) and 2 cm lateral from the axis of the intrauterine tandem. Bladder and rectal reference points were identified according to ICRU 38 recommendations.
- In addition to the ICRU rectal reference point, four additional rectal points were defined at 1 cm interval superior and inferior to the ICRU rectal reference point .
- The dose was prescribed to point A, treatment was carried out using Iridium HDR remote after-loading machine based on the conventional radiograph-based dosimetry.

### **CT-based ICA-HDR dosimetry**

- All the above intracavitary applications were simultaneously taken up for CT planning. CT scans of 3-mm slice-thickness were obtained, 4 cm above the tandem superiorly and to the level of anus inferiorly.



- Rectum and bladder were delineated. Rectum was contoured from recto-sigmoid junction superiorly till ischial tuberosity inferiorly. The entire bladder was contoured. The cervical stopper is identified in 3D using the INSIGHT Software. In the INSIGHT software the CT cuts were reconstructed to form a 3D image. The cervical stopper was used as origin. Treatment planning was carried out using PLATO planning system.
- Point A, ICRU rectal and bladder reference points were identified on CT planning. For each application, the corresponding optimized source positions used in radiograph-based planning were duplicated for CT image-based planning.

Reconstruction of metal applicators using CT images was difficult due to the presence of artifacts.

All bladder and rectal point doses were individually and cumulatively assessed. Statistical analyses was done. The results were obtained.

### **Evaluation: Conventional vs. CT-based dosimetry correlation**

- Cumulative dose volume histogram (cDVH) was calculated for every plan with 1,00,000 calculation points randomly placed in volume of interest.

- To compare the respective ICRU rectal and bladder point doses with the 3D volume dose, the minimum dose value in the 2.0cc volume receiving the highest dose ( $D_2$ ) was determined from DVHs for bladder rectum.  $D_2$  is the dose received by 2cm<sup>3</sup> volume of bladder/rectum. This is calculated from the cumulative Dose Volume Histogram (cDVH) from 3D planning.
- The comparison and correlation of doses to bladder and rectum was carried out using  $D_2$  and the ratio of  $D_2$  to ICRU reference point doses.

## CASE RESULTS AND ANALYSIS

From June 2010 to August 2010 Total of 30 cases of locally advanced cancer cervix patients were included in the study.

### Characteristics

#### 1. Age

Age (Year)	Number of cases
31-40	3 (10%)
41-50	15 (50%)
51-60	12 (40%)

In this study we enrolled patients between 30-60 years of age. Majority of patients were distributed in the age group of 4<sup>th</sup> and 5<sup>th</sup> decades. (Fig. 1)

#### 2. FIGO stage grouping

Stage Grouping	Number of cases
II B	23
III A	0
III B	7

Majority of the patients in the study belong to FIGO stage II B.

Statistical analysis was performed by paired t-test comparing the doses of bladder and rectum in orthogonal x-rays and CT.

## **PARAMETRIC TEST**

To compare the means of two sets of scores, the t-test should be used. Since we were comparing the scores of the same respondents on two variables, the within-subjects (paired samples) t-test was used. The paired t-test involves taking the difference between the two scores for each respondents and finding the mean of these difference scores. The value of the t-statistics was shown, with its degrees of freedom (df) and its probability level (sig 2 tail). If the probability was less than 0.001, we concluded that there was a statistically significant difference between the means of the two sets of scores.

## **EVALUATION**

### Conventional vs. CT-based dosimetry correlation

Cumulative dose volume histogram (cDVH) was calculated for every plan with 1,00,000 calculation points randomly placed in volume of interest.  $D_2$  is the dose received by 2 cm<sup>3</sup> volume of bladder/rectum.  $D_2$  is calculated from cDVH. The comparison and correlation of doses to bladder and rectum was carried out using  $D_2$  and the ratio of  $D_2$  to ICRU reference point doses.

In this study following were analysed.

Dose received by ICRU reference point from orthogonal radiograph based plan and  $D_2$  from cDVH of CT image based plan for bladder and rectum.

<b>Organ</b>	<b>D2 Gy</b>	<b>Dose to ICRU point Gy</b>	<b>D2 /Dose to ICRU ratio</b>
Bladder	5.41	3.22	1.69 $\pm$ (0.20)
Rectum	4.98	3.71	1.36 $\pm$ (0.25)

$D_2$  is the dose received by the 2cm<sup>3</sup> of the volume of critical structure, bladder and rectum. Values given in bladder and rectum or for standard deviation.

The mean  $D_2$  of bladder and ICRU bladder point was 5.41 and 3.22. While for rectum it was 4.98 Gy and 3.71 respectively. Mean  $D_2$  of bladder and rectum was found to be 1.69 and 1.36 times the mean ICRU reference points respectively. This mean difference was statistically significant ( $p < 0.001$ ).

## RESULTS

$\epsilon D_2 / \epsilon$  dose to ICRU reference points

Bladder -  $D_2$  /dose to ICRU reference points Ratio - 1.69 (p<0.001)

Rectum -  $D_2$  /dose to ICRU reference points Ratio - 1.36 (p<0.001)

## INFERENCE

**2D underestimates the bladder dose**

**2D underestimates the rectal dose**

## DISCUSSION

Traditionally, dosimetry of ICA for carcinoma cervix was based on orthogonal radiographs with ICRU 38 recommendations, which allow the evaluation of point doses such as manchester points A, B, ICRU rectal and bladder reference points. Orthogonal radiographs provide spatial information of the applicator with respect to bony structures. However, his time tested system has a limitation of computing the doses received by the volumes of the critical structures as this has only 2D value. Over the past two decades, there have been significant advances in imaging USG, CT, MRI, PET scan. With an advantage of determine the dose volume parameters for the critical structures. We undertook this dosimetric study to compare, validate and document the correlation between point based doses to rectum and bladder with the conventional standard ICRU 38 rectal and bladder points.

In the present study we demonstrated that more precise analysis on the dose received by certain volume of ( $2\text{cm}^3$ ) of organ at risk, bladder and rectum can be accomplished by utilizing cumulative Dose Volume Histogram (CDHs) on CT plan, which may be of critical importance in regard to normal tissue tolerance limits.

The dose to ICRU bladder reference point does not correlate with the maximum dose from the CT planning. Mean  $D_2$  was found to be 1.69

$\pm 0.20$  times the mean ICRU bladder reference points. These results agree with the other studies published in the literature, where the ICRU bladder reference point underestimated the maximum dose by two to three times.

The dose to ICRU rectal point from the radiograph based planning does not correlate with maximum dose from CT Planning. Mean  $D_2$  of rectum was found to be  $1.36 \pm 0.25$  times the mean ICRU rectal reference point, suggesting that there was significant difference between the radiograph based ICRU rectal point and CT based estimation of the parameter  $D_2$ .

ICRU rectal reference point underestimated the maximum dose, and the ratio of the maximum dose and the ICRU rectal dose reported varies in the range of 1.4-2.8<sup>14 16</sup> The large variation reported may be attributed to several factors such as different types of applicators used. Inter observer variability in contouring of critical structures etc., Saarnak et al<sup>16</sup> reported significant inter observer variability in the contouring of critical structures in patients treated with ICBT for carcinoma cervix. As we used rectal catheter which is in the rectal lumen the ICRU reference point dose in 2D is lesser than the  $D_2$  value.



The advent of better imaging modalities, radiation technology and its successful implementation in external beam radiation therapy is a success story today. However implementation of these advances in brachytherapy has been rather sluggish. Various imaging modalities like ultrasound CT, MRI and PET scans etc have been explored in brachytherapy today. Imaging modalities have been invaluable in improving the quality of brachytherapy offered to cancer patients. Their introduction has led to improvements in treatment planning, implementation and assessment, resulting in efficacy and tolerability benefits for patients. CT based Branchytherapy planning is more or less standard of care for most of the sites in the West. The advantages of CT based planning are accurate catheter reconstruction, better delineation of organ-at-risks (OAR) and documentation of dose volume parameters (DVH Parameters). However, the major disadvantage of inaccurate target volume delineation has paved way for MR based Branchytherapy. MR imaging is becoming increasingly popular imaging modality for diagnosis and treatment planning for EBRT and BT. GYN GEC ESTRO Branchytherapy working group has recommended contouring guidelines, concepts and term in 3D image based treatment planning in cervical cancer brachytherapy. Recent reports from Vienna, Paris, Aarhus, Leuven etc., Confirm the safety, feasibility, and definite advantages of MR image based Branchytherapy Planning. Also, there are reports from Vienna and

Paris groups about the clinical outcome and late toxicities supporting the use of MR based Brachytherapy with dose volume adaptation of escalation in locally advanced cervical cancers.

## **WORLDWIDE SCENARIO**

- ▶ MRI is used to plan the intracavitary approaches. Internal treatment is currently performed according to the GEC ESTRO recommendations for image guided 3D gynecological brachytherapy with defined constraints for tumor coverage and the doses to the organs at risk.
- ▶ ICRU 38 guidelines is used to generate standard plan.
- ▶ MR scans with special applicators in situ are made, allowing delineation of target and organs at risk.
- ▶ With this information 3D optimization is performed with respect to the given constraints.

## **COMPARING OUR STUDY WITH REFERENCE STUDY**

In the reference study of Gungor Arslan et al<sup>34</sup>. The maximum rectum and bladder doses in 3D were 1.66 and 1.51 times greater than the ICRU reference rectum and bladder values respectively. Our study correlates well with this study.

In the study of Alison Cameron et al<sup>35</sup> there is a statistically significant difference between ICRU rectal and bladder doses when calculated with CT or orthogonal imaging of about 4%. This study correlates well with our study.

Swamidas V. Jamema, Umesh Mahantshetty et al<sup>36</sup> study states that comparison of orthogonal X-ray and CT-based HDR ICA planning is feasible. ICRU rectal point dose correlates well with maximum rectal dose in 3D, while ICRU bladder point underestimates the maximum bladder dose. Further, incorporation of newer imaging modalities, refinements in applicators and planning systems and wider acceptability of conformal brachytherapy may revolutionize brachytherapy practice in carcinoma cervix. In our study volumetric analysis was not done. Only point based study was done.

In this study radio opaque gauze packing in both anterior and posterior was used to displace the bladder and rectum from the vaginal applicator. The use of radiopaque pack in the vagina of enabled accurate definition of ICRU rectal point and contouring of anterior rectal wall. As we used rectal catheter which is in the rectal lumen the ICRU reference point dose in 2D is lesser than the  $D_2$  value.

## **LIMITATIONS OF THE PROCEDURE**

The successful implementation of image based dosimetry for intracavitary brachytherapy for carcinoma of cervix depends on the accurate delineation of the critical structures and the target volume. The use of metal applicators in the present study produced artifacts that made delineation of the critical structures difficult to some extent.

## **RECOMMENDATIONS**

- Use of CT compatible applicators for better delineation of organ at risk like bladder and rectum. As a result we can escalate the dose to the target.
- In vivo dosimetry can be done to accurate measurement of bladder and rectal doses.
- Weekly fraction of HDR can be consider as soon as patient is fit for ICBT for better local disease control.

## CONCLUSION

Radiotherapy is an effective treatment modality for carcinoma cervix. HDR brachytherapy is incorporated along with EBRT in the treatment protocols.

Our study suggested that maximum bladder and rectal 3D values were 1.69 and 1.36 times greater than the ICRU reference bladder and rectal doses respectively.

Bladder -  $D_2$  /dose to ICRU reference point Ratio - 1.69 ( $p < 0.001$  Statistically significant)

Rectum -  $D_2$  /dose to ICRU reference point Ratio - 1.36 ( $p < 0.001$  Statistically significant)

**2D underestimates bladder dose**

**2D underestimates the rectal dose**

3D - Image based brachytherapy is the standard of care for locally advanced CA cervix patients in western countries. However, image based brachytherapy, is not widely used in developing countries in routine clinical practice due to various limitations. Further, incorporation of newer imaging modalities, refinements in applicators and planning systems and wider acceptability of conformal brachytherapy may revolutionize brachytherapy practices in carcinoma cervix in Government setups in developing countries.

## BIBLIOGRAPHY

- 1a. Perez CA, Camel HM, Kuske RR, Kao MS, Galakatos A, Hederman MA, *et al* Radiation therapy alone in the treatment of Carcinoma of the uterine cervix: A 20 year experience. *Gynecol Oncol* 1986;23:127-40.
- 1b. Carlos A. Perez, M.D., et al Radiation therapy morbidity in carcinoma of the uterine cervix: Dosimetric and clinical correlation *Int. J. Radiation Oncology Biol. Phys.*, Vol. 44, 1999.
2. Thompson S, Delaney G, Gabriel GS, Jacob S, Das P, Barton M. Estimation of the optimal brachytherapy utilization rate in the treatment of carcinoma of the uterine cervix: Review of clinical practice guidelines and primary evidence. *Cancer* 2006;107:2932-41.
3. International Commission on Radiation Units and Measurements (ICRU) Report 38: Dose and volume specification for reporting intracavitary brachytherapy in gynecology: 1985.
4. Kim RY, Pareek P. Radiography based treatment planning compared with computed tomography (CT) based treatment planning for intracavitary brachytherapy in cancer of the cervix: Analysis of dose volume histograms. *Brachytherapy* 2003;2:200-6.
5. Fellner C, Potter R, Knocke TH, Wambersie A. Comparison of radiography and computed tomography based treatment planning in cervix cancer in brachytherapy with specific attention to some quality assurance aspects. *Radiother Oncol* 2001;58:53-62.
6. Pelloski CE, Palmer M, Chronowski GM, Jhingran A, Horton J, Eifel PJ. Comparison between CT-Based volumetric calculations and ICRU reference point estimates of radiation doses delivered to bladder and rectum during intracavitary radiotherapy for cervical cancer. *Int J Radiat Oncol Biol Phys* 2005;62:131-7.
7. Shin Kil, Kim TTI, Cho JK, Kim JY, Park SY, Part Sy et al. CT guided intracavitary radiotherapy for cervical cancer : Comparison of conventional point A plan with clinical target volume based three dimensional plan using dose volume parameters *Int J Radiat Oncol Biol Phys* 2006; 64:197-204.
8. Deshpande DD, Shrivastava SK, Pradhan AS, Viswanathan PS, Dinshaw KA. Dosimetry of Intracavitary applications in carcinoma of the cervix: Rectal dose analysis. *Radiother Oncol* 1997;42:163-6.
9. Esche BA, Crook JM, Isturiz J, Horiot JC. Reference volume, milligram hours and external radiation for the Fletcher applicator. *Radiother Oncol* 1987;9:255-61.
10. Bellotti JE, Kagan AR, Wollin M, Olch A. Application of the ICRU Report 38 reference volume concept to the radiotherapeutic management of recurrent

endometrial and cervical carcinoma. *Radiother Oncol* 1993;26:254-9.

11. Barillot I, Horiot JC, Maingon P, Bone-Lepinoy MC, Vaillant D, Feutray S. Maximum and mean bladder dose defined from ultrasonography: Comparison with the ICRU reference in gynaecological brachytherapy. *Radiother Oncol* 1994;30:231-8.
12. Wilkinson JM, Ramachandra TP. The ICRU recommendations for reporting intracavitary therapy in gynaecology and the Manchester method of treating cancer of the cervix uteri. *Br J Radiol* 1989;62:362-5.
13. Kapp KS, Stuecklschweiger GF, Kapp DS, Hackl AG. Dosimetry of intracavitary placements for uterine and cervical carcinoma: Results of orthogonal film, TLD and CT assisted techniques. *Radiother Oncol* 1992;24:137-46.
14. Ling CC, Schell MC, Working KR, Jentzsch K, Harisiadis L, Carabell S, *et al*. CT assisted assessment of bladder and rectum dose in gynecological implants. *Int J Radiat Oncol Biol Phys* 1987;13:1577-82.
15. Schoepel SL, La Vigne ML, Martel MK, McShan DL, Fraass BA, Roberts JA. Three Dimensional treatment planning of intracavitary gynecologic implants: Analysis of 10 cases and implications for dose specification. *Int J Radiat Oncol Biol Phys* 1994;28:277-83.
16. Saarnak AE, Boersma M, van Bunningen BN, Wolterink R, Steggerda MJ. Inter-observer variation in delineation of bladder and rectum contours for brachytherapy of cervical cancer. *Radiother Oncol* 2000;56:37-42.
17. van den Bergh F, Meerteens H, Moonen L, van Bunningen B, Blom A. The use of a transverse CT image for the estimation of the dose given to the rectum in intracavitary brachytherapy for carcinoma of the cervix. *Radiother Oncol* 1998;47:85-90.
18. Kuipers T, Visser A. Technical aspects of bladder dosimetry in intracavitary irradiation of cervix carcinoma. *Radiother Oncol* 1986;7:7-12.
19. Tan LT, Warren J, Freestone G, Jones B. Bladder dose estimation during intracavitary brachytherapy for carcinoma of the cervix using a line source system. *Br J Radiol* 1996;69:953-62.
20. Sauer O, Gotz-Gersitz U, Gullenstern M, Baier K, Herbolsheimer M. Precision of the dose calculated for bladder and rectum in high dose rate gynaecological brachytherapy. *Endocuriether Hyperther Oncol* 1994;10:79-82.
21. Thomadsen BR, Shahabi S, Stitt JA, Buchler DA, Fowler JF, Paliwal BR, *et al*. High dose rate intracavitary brachytherapy for carcinoma of the cervix: The Madison system: II, procedural and physical considerations. *Int J Radiat Oncol Biol Phys* 1992;24:349-57.
22. Grigsby PW, Georgiou A, Williamson JF, Perez CA. Anatomic variation of gynaecologic brachytherapy prescription points. *Int J Radiat Oncol Biol Phys*

1993;27:725-9.

23. Subak LL, Hricak H, Powell CB, Azizi L, Stern JL. Cervical carcinoma: Computed tomography and magnetic resonance imaging for preoperative staging. *Obstet Gynecol* 1995;86:43-50.
24. Kim SH, Choi BI, Han JK, Kim HD, Lee HP, Kang SB, *et al* . Preoperative staging of uterine cervical carcinoma: Comparison of CT and MRI in 99 patients. *J Comput Assist Tomogr* 1993;17:633-40.
25. Hellebust TP, Dale E, Skjonsberg A, Oslen DR. Interfraction variations in rectum and bladder volumes and dose distributions during high dose rate brachytherapy treatment of the uterine cervix investigated by repetitive CT examination. *Radiother Oncol* 2001;60:273-80.
26. Elzbieta Senkus, Konefka M.D., *et al*-Patient related factors determining geometry of intracavitary applicators and pelvic dose distribution during cervical cancer brachytherapy. *Int. J. Radiation Oncology Biol. Phys.*, Vol 37, 1997.
27. Robson Ferringo, M.D., *et al* HDR brachytherapy in the treatment of uterine cervix cancer. Analysis of two different methods *Int. J. Radiation Oncology Biol. Phys.*, Vol 21, 1991.
28. Subir Nag, M.D., *et al* The American Brachytherapy society recommendations for High Dose Rate Brachytherapy for carcinoma of the cervix. *Int. J. radiation Oncology Biol, Phys.*, Vol. 48, 2000.
29. John C. Roeske, Ph.D., *et al* Late rectal sequelae following definitive radiation therapy for carcinoma of the uterine cervix: A dosimetric analysis *Int. J. Radiation Oncology Biol.Phys.*, Vol. 37, 1997.
30. Chong-Jong Wang, M.D., *et al* Clinical comparison of two linear Quadratic model based isoeffect fractionation schemes of High dose rate intracavitary brachytherapy for cervical cancer *Int. J. Radiation Oncology Biol., Phys.*, Vol 59, 2004.
31. Tod M, Meredith W. A dosage system for use in the treatment of cancer of the uterine cervix, *Br J Radiol* 1938; 11:809-824.
32. Tod M, Meredith W. Treatment of cancer cervix a revised "Manchester Method." *Br J Radiol* 1953; 26:252-257.
33. Colin G. Orton, Ph.D., *et al* Comparison of low and high dose rate remote afterloading for cervix cancer and the importance of fractionation *Int. J. Radiation Oncology Biol. Phys.*, Vol 21, 1991.
34. **Comparison of conventional and CT-based planning for intracavitary brachytherapy for cervical cancer: target volume coverage and organs at risk doses** Cem Onal, <sup>1</sup> Gungor Arslan,<sup>#1</sup> Erkan Topkan,<sup>#1</sup> Berrin Pehlivan,<sup>#1</sup> Melek Yavuz,<sup>#1</sup> Ezgi Oymak,<sup>#1</sup> and Aydin Yavuz<sup>#1 1</sup>Department of Radiation Oncology, Baskent University Medical Faculty, Adana, Turkey. 2008.



35. **Comparison between CT and Orthogonal Based Calculation of ICRU Rectal and Bladder Doses During Intracavity Brachytherapy for Cervix Cancer- Are Orthogonal Films now Obsolete?** Alison Cameron<sup>1</sup>, Helen Coomber<sup>2</sup>, Chris French<sup>2</sup>, Paul Cornes<sup>1</sup> -<sup>1</sup>Oncology Department, Bristol Haematology Oncology Centre (BHOC), UK; <sup>2</sup>Radiotherapy Physics Unit, BHOC, UK, 2006.
36. **Dosimetric evaluation of rectum and bladder using image-based CT planning and orthogonal radiographs with ICRU 38 recommendations in intracavitary brachytherapy** Swamidas V. Jamema, Sherly Saju, Umesh Mahantshetty,<sup>1</sup> S. Pallad,<sup>1</sup> D. D. Deshpande, S. K. Shrivastava,<sup>1</sup> and K. A. Dinshaw<sup>1</sup>: Department of Medical Physics, Tata Memorial Hospital, Mumbai, India. Department of Radiation Oncology, Tata Memorial Hospital, Mumbai, India 2007.
37. Montana G.S., Fowler, W.C., et al Carcinoma of the cervix : Analysis of bladder and rectal radiation dose complications Int. J. Radiation Oncology Biol.Phys., Vol. 16, 1989.
38. Willett CG, et al Acute and late toxicity of patients with inflammatory bowel disease undergoing irradiation for abdominal and pelvic neoplasms Int.J. Radiation Oncology Biol.Phys., Vol 46, 2000.

## **ABBREVIATIONS**

<b>AAPM</b>	-	American Association of Physicists in Medicine
<b>ABS</b>	-	American Brachytherapy Society
<b>AAR</b>	-	Age Adjusted Rate
<b>BED</b>	-	Biological Effective Dose
<b>BT</b>	-	Brachytherapy
<b>3D CRT</b>	-	3D Conformal Radiotherapy
<b>DART</b>	-	Dynamic Adaptive Radiotherapy
<b>EBRT</b>	-	External Beam Radiation Therapy
<b>EORTC</b>	-	European Organisation for Research & Treatment of Cancer
<b>FIGO</b>	-	Federation Internationale Gynaecology & Obstetrics
<b>GOG</b>	-	Gynaecology Oncology group
<b>HFRT</b>	-	Hyperfractionated Radiotherapy
<b>HDR</b>	-	High Dose Rate
<b>ICRU</b>	-	International Commission of Radiation Units and Measurements

<b>ICBT</b>	-	Intracavitary Brachytherapy
<b>ICA</b>	-	Intracavitary Application
<b>GEC</b>	-	The Group European de curie therapy
<b>ESTRO</b>	-	European Society for Therapeutic Radiology and Oncology
<b>IGRT</b>	-	Image Guided Radiotherapy
<b>IMRT</b>	-	Intensity Modulated Radiotherapy
<b>MMTR</b>	-	Madras Metropolitan Tumor Registry
<b>NRC</b>	-	Nuclear Regulatory Commission
<b>RTOG</b>	-	Radiation Therapy Oncology group
<b>RT</b>	-	Radiation Therapy
<b>SCC</b>	-	Squamous Cell Carinoma
<b>SWOG</b>	-	South West Oncology group
<b>TNM</b>	-	Tumor Node Metastasis

**DEPARTMENT OF RADIATION ONCOLOGY**  
**MADRAS MEDICAL COLLEGE, CHENNAI – 600 003.**

**Informed Consent Form**

பெயர் :

வயது :

ஊர் :

பாலினம் :

..... ஆகிய நான் என் முழு  
மனதுடன் தெரிவிப்பது,

என்னுடைய நோயின் தன்மை பற்றியும் எவ்விடம் அந்நோய் உள்ளது என்பது பற்றியும் மருத்துவர் மூலம் தெரிந்துகொண்டேன். எனக்குப் புற்றுநோய் உள்ளதால், அதற்குக் கதிர்வீச்சு சிகிச்சை மற்றும் **CT Scan Simulation** பெறுவதற்கு முழு சம்மதம் அளிக்கிறேன். கதிர்வீச்சு சிகிச்சையினால் ஏற்படும் பக்கவிளைவுகளை பற்றியும் தெரிந்து கொண்டேன்.

என் உடல் நன்மைக் கருதி செய்யப்படும் இவ்வகை மருத்துவத்திற்கு நானும் என் குடும்பத்தாரும் முழுமனதுடன் சம்மதிக்கின்றோம். மேலும், இதனால் வரும் பக்க விளைவுகளுக்கு மருத்துவரோ மருத்துவமனையோ பொறுப்பல்ல என மனப்பூர்வமாக சம்மதிக்கிறேன்.

(நோயாளியின் உறவினரின் கையொப்பம்)

(நோயாளியின் கையொப்பம்)