

Electronic Nose Calibration Process for Monitoring Atmospheric Hazards in Confined Space Applications

M.A.A. Bakar¹, A.H. Abdullah¹, F.S.A. Sa'ad¹, S.A.A. Shukor¹, A.A.A. Razak¹ and M.H. Mustafa²

¹*School of Mechatronic Engineering, Universiti Malaysia Perlis, 02600 Arau, Perlis, Malaysia.*

²*Electrosoft Engineering, 42, Lorong 24, Taman Petani Jaya, 08000 Sungai Petani, Kedah, Malaysia.*

ijatbakar@gmail.com

Abstract—Confined space is an enclosed area with limited space to perform work activity which could contribute towards atmospheric hazards accidents. The atmospheric air sample can be monitored using the integration of electronic nose (e-nose) together with mobile robot. In this work, we reported the calibration of e-nose which consists of three individual Metal Oxides Semi-Conductor (MOS) gas sensors together with oxygen, temperature and humidity sensors for environmental monitoring. The sample gas is using two different gas cylinders. Gas cylinder 1 contains of hydrogen sulphide (H₂S), carbon monoxide (CO) and methane (CH₄) while gas cylinder 2 contains air with zero grades. The analogue to digital converter (ADC) readings from the MOS gas sensors response is converted into parts per million (ppm) and percentage (%) readings. The concentrations of gas in cylinders were validated using commercial gas detector. The difference readings between the MOS gas sensors in e-nose and commercial gas detector to the gas cylinder 1 is calculated as calibrated value. The gas cylinder 2 exposed is to identify the ability of MOS gas sensors to back in baseline level. Results proved the ability of the developed e-nose to be use in environmental gas detections and monitoring.

Index Terms—Confined Space; Atmospheric Hazards; Electronic Nose; Calibration and Validation.

I. INTRODUCTION

The development of devices for air quality monitoring has been significantly increasing nowadays. Air quality needs to be monitored due to its important for environment especially in a confined space. Occupational Safety and Health (OSHA) and National Institute of Occupational Safety and Health (NIOSH) state that the atmospheric hazards in confined space were serious environmental problem that threatens the workers safety[1]. Confined space can be described as any enclosed area with limited space to perform work activity and it is not designed for continuous work. For example chambers, tanks, manhole, vat, silo, pit, pipe, flue and underground room[2].

Atmospheric hazards cannot be sense by touch or sight. It is very dangerous compared to physical hazards which can be seen and able to alert worker in order to be ready with safety precaution. The most critical atmospheric hazards in confined space are oxygen deficiencies, explosive atmospheres and attendance of toxic gases[3]. Before workers enter the confined space, a pre-entry test needs to be conducted to avoid any atmospheric hazards accident. Several factors that lead towards an accident or common mistakes in confined space are defined in previous work[4]. It can be extremely dangerous if the pre-entry test for atmosphere testing in

confined space is not performed and usually it is being done by using single instrument.

The electronic nose (e-nose) device may be used in variety of applications in safety, food quality, plant disease and environmental monitoring[5]. An e-nose is developed to imitate human capabilities using integrations between software and hardware to perform pattern recognition for identification and classification. In the confined space applications, an e-nose carried by a mobile robot is a way on how technology can help to perform the pre-entry for atmosphere testing[6].

In this paper, the work on calibration the e-nose device that has been developed is highlighted. The main objective is to ensure readings from the developed e-nose are consistent and able to be used similarly with other gas detector in the market. Next is to determine the accuracy of the e-nose readings. Finally, is to establish the reliability of the e-nose to be used in real environment for atmospheric hazards monitoring in confined space applications. The calibration is conducted to identify the percentage (%) error between the e-nose and a commercial gas meter reading. It is also to identify the ability of e-nose to reverse back to its baseline level when exposed to the air with zero grades. It is also to clean the sensors chamber and identify the ability of MOS gas sensors to sense in lowest response.

II. ELECTRONIC NOSE DEVELOPMENT

The e-nose device has been developed at the Research Room II at School of Mechatronic Engineering, Universiti Malaysia Perlis (UniMAP) and Electrosoft Engineering, Sungai Petani, Kedah. Figure 1 shows the general e-nose system and component which consists of sensing module, data acquisition, wireless communication and control software. The e-nose components are including air inlet and outlet, active carbon filter, electro-valve, sensors chamber, electric air pump, microcontroller, keypad, liquid-crystal display (LCD) and personal computer.

A. Hardware and software development

The e-nose body design has a size of 30cm (L) x 22cm (W) x 14cm (H). It is designed based on the criteria of the underground tunnel (confined space) and can be carried by a mobile robot to move around. The size of sensors chamber is 15cm (L) x 3.5cm (W) x 3.5cm (H) and it is airtight. It is constructed from Teflon or polytetrafluoroethylene (PTFE) material because of its porosity and inert characteristics[7]. The sensors chamber is developed to ensure sensors stability,

repeatability and reproducibility[8]. It also must be designed to ensure all sensors that placed inside can be exposed to the air sample with an optimal sense.

Three individual Metal Oxides Semi-Conductor (MOS) gas sensors from Figaro and Synkera brand are located in a sensor chamber as listed in Table 1. The oxygen (O₂), temperature and humidity sensors are also included in the development of e-nose but are placed outside from sensors chamber for environmental monitoring purpose.

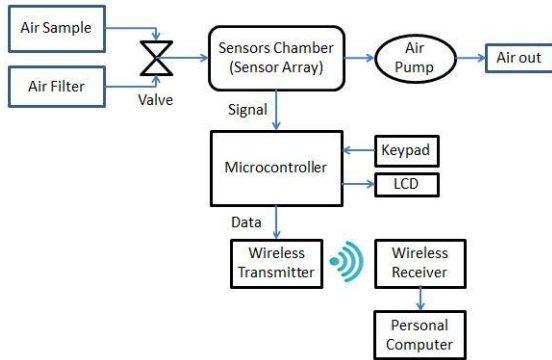

Figure 1: General e-nose system

Table 1
List of Sensors

Sensors	Parameter	Detection Range (Unit)
TGS 2442	Carbon Monoxide	1 to 1000 (ppm)
P/N 714	Hydrogen Sulphide	1 to 100 (ppm)
TGS 2612	Methane	1 to 25 (%)
SK-25F	Oxygen	0 to 30 (%)
SHT 75	Temperature	-40 to 123.8 (°C)
	Humidity	0 to 100 (%RH)

The microcontroller (dsPIC33FJ128MC706A) is used as the e-nose control unit. Basically, the MOS gas sensor must be heated to a certain temperature at a certain time for optimum response during operation [9]. The analogue to digital (ADC) interface is functioned to convert sensors response in terms of voltage signal into digital form to be acquired by the microcontroller. The microcontroller converts the sensors response signals to 12 bits (4096) as ADC readings. The readings are sent via wireless ZigBee (MRF24J40C) with 2.4 GHz IEEE Std. 802.15.4™ RF communication. The ZigBee transmitter and receiver set at 9600 baud rates to communicate and data received will be interpreted by control software in personal computers. Figure 2 shows the e-nose full hardware development.

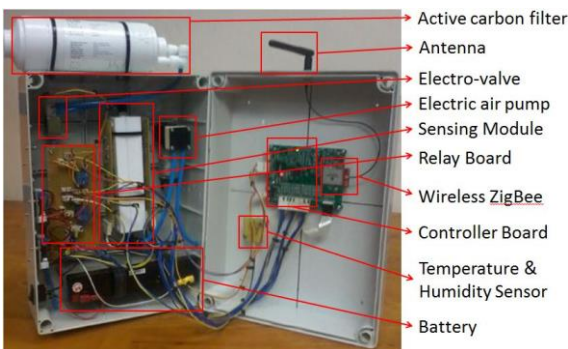

Figure 2: E-nose full hardware development

Software Visual Basic 6.0 as Graphic User Interface (GUI) was designed to show the readings from sensors response as shown in Figure 3. The GUI will help to present the readings in real time monitoring for more visualization.

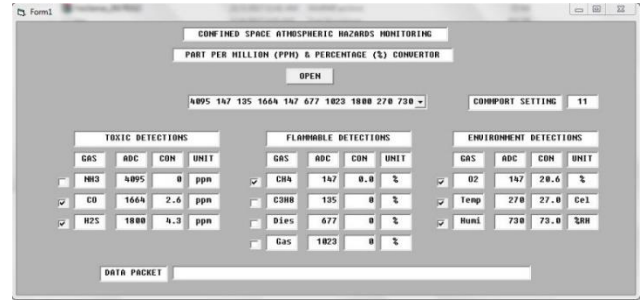

Figure 3: Graphic User Interface (GUI)

B. Parts per million and percentage conversion

In the presence of gas in the air space, the MOS gas sensors are sensitive and response by changing the conductivity[10]. The ADC will change the MOS gas sensors response signals into voltage signals in millivolt (mV) and the 741 Op-amp is used to amplify the signals. The GUI was programmed to convert from ADC readings into parts per million (ppm) and percentage readings based on concentrations of gas in the air by using Equation 1 till Equation 6 which will be discussed next.

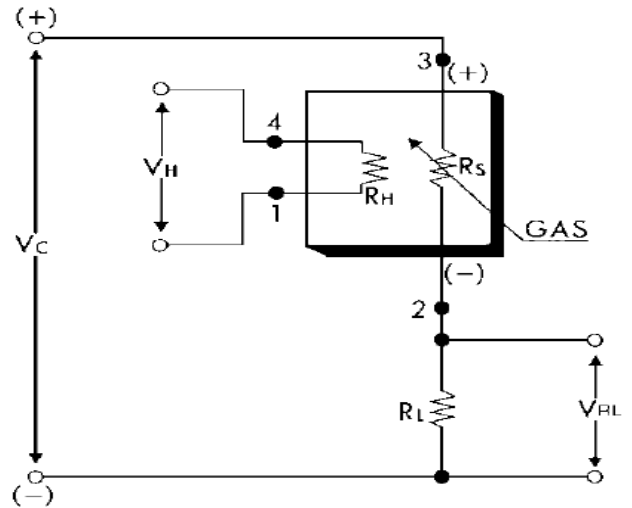

Figure 4: MOS gas sensor circuit diagram

Figure 4 shows the MOS gas sensor circuit diagram which consist of two input voltage which are Heater Voltage (V_H) for sensor heating and Circuit Voltage (V_C) for sensor response. The Resistive Load Voltage (V_{RL}) as Output Voltage (V_{out}) is measured between Load Resistor (R_L). To calculate the V_{out} Equation 1 is used and the Sensor Response (R_s) is calculated by using Equation 2.

$$\frac{ADC}{4096} = \frac{V_{out}}{5} \tag{1}$$

$$R_s = \frac{V_C - V_{out}}{V_{out}} [R_L] \tag{2}$$

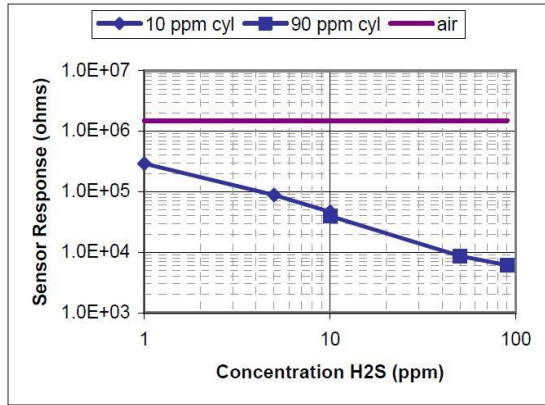

Figure 5: Graph of hydrogen sulphide (H₂S) sensor response versus concentrations

Figure 5 shows the hydrogen sulphide sensor response versus concentrations provided from the manufacturer[11]. The graph shows the linearity between sensor response at *Y*-axis represent as *Rs* and hydrogen sulphide concentrations at *X*-axis but the graph pattern is in logarithm of 10. To convert *Rs* into ppm the gradient (*m*) and the constant value (*K*) that intersect at *X*=1 needs to be calculated using Equation 3 and 4.

$$m = \frac{\Delta(\log y)}{\Delta(\log x)} \quad (3)$$

$$y = Kx^m \quad (4)$$

From then, the ppm value can be calculated by using equation 5.

$$x = 10^{\left[\frac{\log\left(\frac{y}{k}\right)}{m} \right]} \quad (5)$$

For explosion gas such as methane, the concentration in the air is measured using percentage readings. Equation 6 can be used to convert ppm into percentage.

$$x_{\%} = \frac{x_{ppm}}{10000} \quad (6)$$

III. EXPERIMENTAL SETUP

The calibrations process for this e-nose device have been conducted at the laboratory of Biomaterials at the School of Mechatronics Engineering at UniMAP. When handling the hazardous gas, the e-nose must be tested in a fume hood for safety reasons. Figure 6 shows the e-nose in the fume hood for gas sample exposure. Two types of gas cylinders are used to expose the gas sample to the e-nose. This were done to identify the difference readings as calibration value and the percentage error (*%error*) using gas cylinder 1 having the composition of gas concentrations to 10 ppm for hydrogen sulphide (H₂S), 50 ppm for carbon monoxide (CO) and 2.9% for methane (CH₄). Then the fresh air is performed using the gas cylinder 2 expose having composition of air with zero grades (<1 ppm).

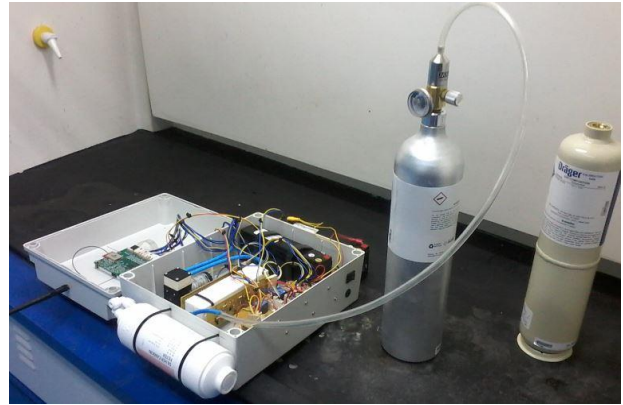

Figure 6: The e-nose in a fume hood for gas exposure

To conduct the experiment, firstly, the MOS gas sensors will be preheated by the period that required period for 90s. Then, the gas sample from the gas cylinder 1 which contains of hydrogen sulphide (H₂S), carbon monoxide (CO) and methane (CH₄) was sucked (sniffed) into the sensors chamber by using electric air pump with a maximum power of 100 kilopascals (kPa). On top of the cylinder also has adjustable air regulator set to one bar to deliver gas sample into the sensors chamber. The gas sample will flow through the tube to expose to the MOS gas sensors in the chamber for two minutes. During this time, the device was programmed to record about 100 readings from sensors response to the concentrations of gas sample that is being exposed.

The gas cylinder 1 is then closed and replaced with gas cylinder 2 contains an air zero grade (<1 ppm) to be sniffed by the e-nose. About 100 readings were also recorded for the gas cylinder 2 exposed. The gas cylinder 2 is then closed and all MOS gas sensors will return to the baseline levels. This process was repeated to five times for each gas cylinders in same average condition of oxygen (20.8%), temperature (25°C) and humidity (75%RH) level.

To ensure the readings from MOS gas sensors against the concentrations of the exposed gas sample are correct, both gas cylinders were also exposed to a commercial gas detector, Altair 5X Multi Gas Detector from MSA Company. The aim is to validate the readings to the concentrations of gas sample from both gas cylinders that have been used. This detector is capable to detect H₂S, CO, CH₄ and O₂. The reading shown by this detector will serve as a reference reading for calibrating MOS gas sensors in the developed e-nose.

The environmental conditions for temperature and humidity level are validated using commercially available detector, Humidity Alert II from Extech Company. During the experiment, the temperature and humidity readings shown by this detector will be recorded and will be compared with the temperature and humidity sensors readings from the e-nose. Both detectors as well as the temperature and humidity level detectors are shown in Figure 7.

Minitab Pro 16 software was used to plot the data recorded by the MOS gas sensors during the e-nose exposure to both gas cylinders. The goal is to identify the trend from the sensors response and its ability for optimum readings during exposure to the concentrations of gas sample. Five readings are taken for each sensor.



Figure 7: Altair 5x Multi Gas Detector and Humidity Alert II

IV. RESULTS AND DISCUSSIONS

Figure 8 to 10 show the readings from sensors response for H₂S, CO and CH₄ during the two minutes exposure to the gas cylinder 1. The readings from sensors response to the concentrations of H₂S and CO indicates ascending against time while the concentrations of CH₄ sensor response indicate horizontally against time. The average time to achieve the highest readings in stable based on MOS gas sensors ability is 96s for the H₂S, 91.2s for CO and 90.48s for CH₄ sensors. The average highest reading from the sensors response is 9.66 ppm for H₂S, 47.38 ppm for CO and 2.05% for CH₄. Table 2 shows the five highest readings for the H₂S, CO and CH₄ sensors when exposed to the gas cylinder 1.

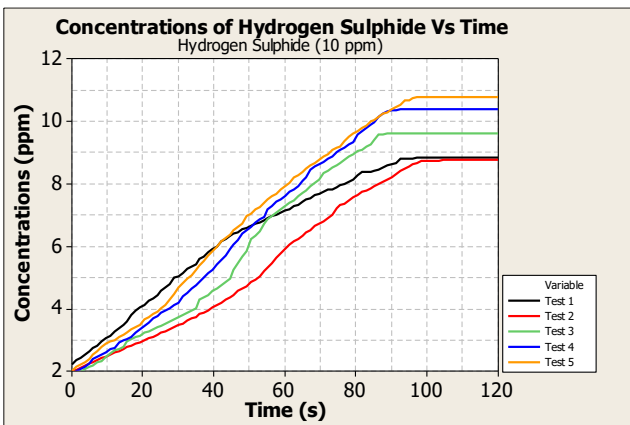

Figure 8: Graph of H₂S concentrations (10 ppm) versus time

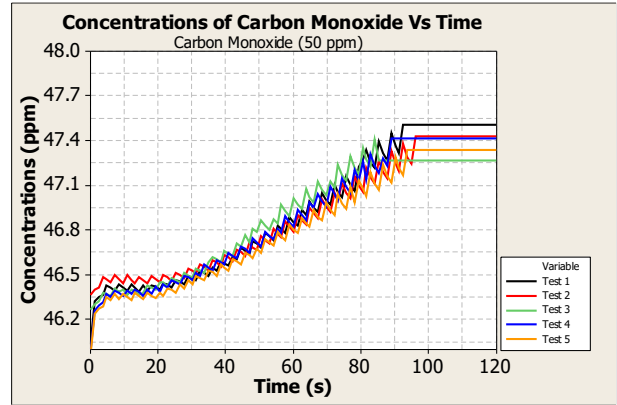

Figure 9: Graph of CO concentrations (50 ppm) versus time

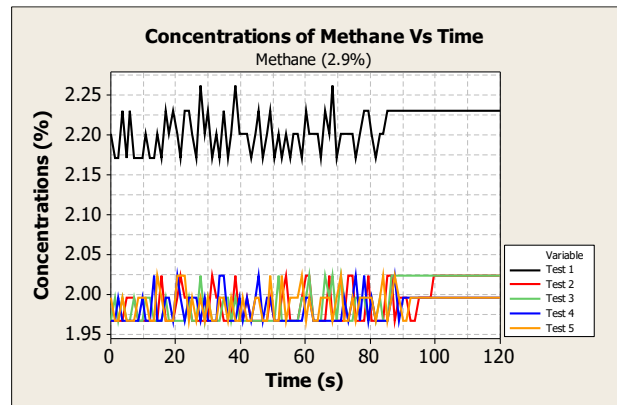

Figure 10: Graph of CH₄ concentrations (2.9%) versus time

Table 2
Five Highest Readings for H₂S, CO and CH₄

	H ₂ S (ppm)	CO (ppm)	CH ₄ (%)
Test 1	8.82	47.50	2.23
Test 2	8.75	47.43	2.02
Test 3	9.60	47.26	2.02
Test 4	10.38	47.41	1.99
Test 5	10.76	47.33	1.99
Average	9.66	47.38	2.05
Reference (Altair 5x)	10.00	50.00	2.9
Different	+0.34	+2.62	+0.85
(%) Error	3.40	5.24	29.31

The highest average reading is calculated for each sensor to be compared to the reference reading. The gas detector readings were also recorded, to validate and to prove the concentrations from the gas sample that has been used is reliable. The difference of readings between gas detector and e-nose shown by the H₂S sensor is +0.34 ppm, CO sensor is +2.62 ppm and CH₄ sensor is +0.85%. Results from these differences readings will be used as the calibration values for each sensor when performing next detections. The percentage error was than calculated and it shows 3.40% for H₂S, 5.24% for CO and 29.31% for CH₄.

Figure 11 till Figure 13 shows the readings from sensors response for H₂S, CO and CH₄ sensors during the two minutes exposure towards the gas cylinder 2. The readings from sensors response to concentrations of H₂S and CO indicates descending against time while the concentrations of CH₄ sensor response indicate horizontally against time. The average time to achieve the highest readings to stable based on the gas concentrations is 58.88s for H₂S, 54.24s for CO and 56.64s for CH₄ sensors. Table 3 shows the five lowest

readings for the H₂S, CO and CH₄ sensors during exposing to the gas cylinder 2.

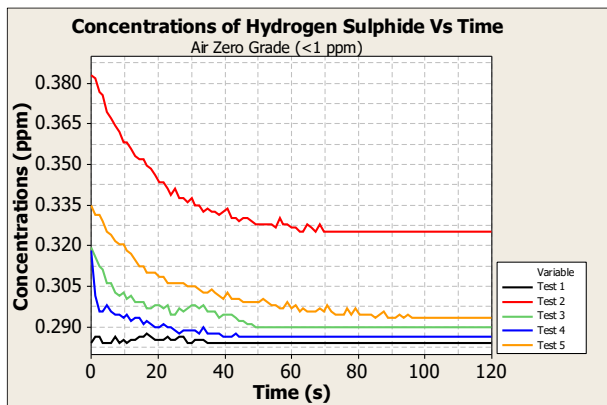

Figure 11: Graph of H₂S concentrations (<1 ppm) versus time

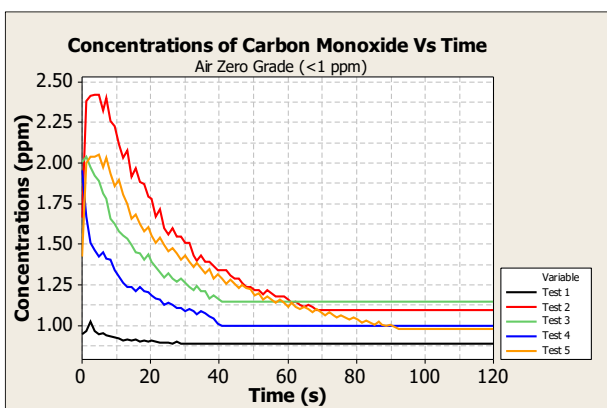

Figure 12: Graph of CO concentrations (<1 ppm) versus time

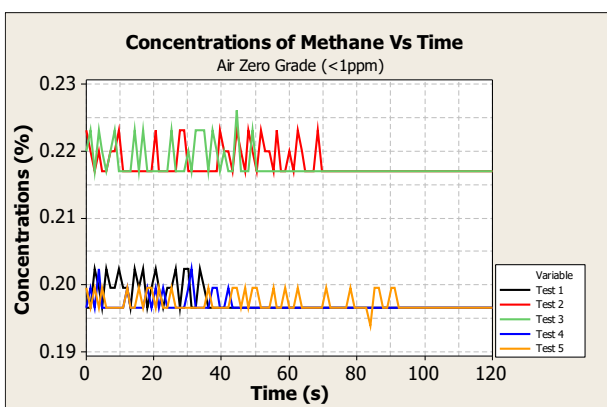

Figure 13: Graph of CH₄ concentrations (<1 ppm) versus time

The average lowest readings were calculated to identify the final lowest readings for every sensor. The lowest readings shown by the H₂S sensor is 0.29 ppm, CO sensor is 0.99 ppm and CH₄ sensor is 0.19%. The gas detector readings are also recorded, it is to validate and to prove the concentrations from the gas sample that has been used is reliable.

V. CONCLUSION

In conclusion, the calibration and validation for this e-nose device has been successfully conducted. The percentage error has been calculated and identified. The readings for H₂S and CO sensors has demonstrated less than 10% while CH₄ it is

slightly more but still acceptable to use because of its closely response to the concentrations of gas sample. During gas cylinder 2 expose, the ability of MOS gas sensors has been proved to sense the lowest concentrations below than one ppm when exposed to the air with zero grades. The results has proved the ability of the e-nose device to be use in environmental gas detection and monitoring, especially for critical area like confined space. In the future, the e-nose device will be integrated with a mobile robot for olfaction applications in a confined space to prove its reliability and functionality in real environment.

Table 3
Five Lowest Readings for H₂S, CO and CH₄

	H ₂ S (ppm)	CO (ppm)	CH ₄ (%)
Test 1	0.28	0.87	0.19
Test 2	0.32	1.05	0.21
Test 3	0.29	1.10	0.21
Test 4	0.28	0.98	0.19
Test 5	0.29	0.96	0.19
Average	0.29	0.99	0.19
Reference (Altair 5x)	0.00	0.00	0.00

ACKNOWLEDGMENT

This work is partly funded by the Ministry of Science, Technology & Innovation Malaysia (MOSTI) under the Science Fund Research Grant Scheme (Project No: 03-01-15-SF0257). The authors also gratefully acknowledges to Universiti Malaysia Perlis (UniMAP) for the opportunities given to do the research.

REFERENCES

- [1] D. Burlet-vienney, Y. Chinniah, A. Bahloul, and B. Roberge, "Design and application of a 5 step risk assessment tool for confined space entries," *Saf. Sci.*, vol. 80, pp. 144–155, 2015.
- [2] D. Burlet-vienney, Y. Chinniah, A. Bahloul, and B. Roberge, "Occupational safety during interventions in confined spaces," *Saf. Sci.*, vol. 79, pp. 19–28, 2015.
- [3] H. Ye, "Atmosphere Identifying and Testing in Confined Space," in 2011 International Conference on Instrumentation, Measurement, Computer, Communication and Control, 2011, pp. 767–771.
- [4] T. Suski, "Common Mistakes in CONFINED SPACE MONITORING," *Occupational Hazards*, pp. 53–55, 2005.
- [5] F. Ro, N. Barsan, and U. Weimar, "Electronic Nose : Current Status and Future Trends," *Am. Chem. Soc.*, vol. 108, no. 2, pp. 705–725, 2008.
- [6] K. Dandan, H. Albitar, A. Ananiev, and I. Kalaykov, "Confined Spaces : Cleaning Techniques and Robot-based Surface Cleaning," *Am. Sci. Res. J. Eng. Technology, Sci.*, vol. 22, no. 1, pp. 210–230, 2016.
- [7] R. Rousier, S. Bouat, T. Bordy, H. Gâteau, M. Darboux, and P. Montméat, "Gas chamber design for multi chemical sensors," in IMCS 2012-The 14th International Meeting on Chemical Sensors, 2012, pp. 1714–1717.
- [8] M. Mamat and S. A. Samad, "The Design and Testing of an Electronic Nose Prototype for Classification Problem," in 2010 International Conference on Computer Applications and Industrial Electronics (ICCAIE 2010), 2010, pp. 382–386.
- [9] G. F. Fine, L. M. Cavanagh, A. Afonja, and R. Binions, "Metal Oxide Semi-Conductor Gas Sensors in Environmental Monitoring," *sensors*, vol. 10, pp. 5469–5502, 2010.
- [10] FIGARO, "Operating Principle MOS Type." [Online]. Available: www.figarosensor.com/technicalinfo/principle/mos-type.html.
- [11] I. Synkera Technologies, "Hydrogen Sulfide (H2S) Data Sheet (P/N 714)." [Online]. Available: www.gassensor.ru/data/files/hydrogen_sulfide/H2S-PN714.pdf.