

Low Power All-Digital Radio-over-Fiber Transmission for 28-GHz Band using Parallel Electro-Absorption Modulators

H. Li¹, J. Van Kerrebrouck¹, H. Ramon¹, L. Bogaert^{1,2}, J. Lambrecht¹, C.-Y. Wu¹, L. Breyne^{1,2}, J. Declercq¹, J. Bauwelinck¹, X. Yin¹, P. Ossieur¹, P. Demeester¹ and G. Torfs¹

¹IDLab, INTEC, Ghent University - imec, 9052 Ghent, Belgium

²Photonics Research Group, INTEC, Ghent University - imec, 9052 Ghent, Belgium
haolin.li@ugent.be

Abstract: We present a low-power all-digital radio-over-fiber transmitter for beyond 28-GHz using sigma-delta modulation, a 140mW NRZ driver and parallel electro-absorption modulators. 5.25Gb/s (2.625Gb/s) 64-QAM is transported over 10-km SSMF at 1560nm with 7.6% (5.2%) EVM.

OCIS codes: (060.2330) Fiber optics communications; (060.5625) Radio frequency photonics

1. Introduction

The fifth generation wireless networks (5G) drive research in the direction of massive device connectivity, high data rates and decreased latency. One of the features introduced with 5G is the deployment of small cells and the utilization of mm-wave frequency bands. Cloud radio access networks (C-RANs) in combination with radio-over-fiber (RoF) can be a key-enabling technology to realize this [1]. Three different realizations of the RoF link, including digitized RoF (DRoF), analog RoF (ARoF) and sigma-delta-over-fiber (SDoF), have been discussed in prior works [2-4]. SDoF simplifies remote radio heads (RRHs) by oversampling the signal and translating it to a bi-level signal, combining the benefits of both the DRoF (low-cost telecom components) and the ARoF (low-complexity RRHs).

However, the required sampling rate will go impractically high for >24 GHz bands in 5G New Radio (NR) [5] and the 60 GHz band used by WiGig. To achieve a high sampling rate of the sigma-delta modulator (SDM), a low-latency parallelization technique is required and a final multiplexer (MUX) is then indispensable to serialize these parallel outputs again into a serial digital stream. The most common approach of SDoF transmission uses two low-pass SDMs followed by a digital quadrature up-conversion, requiring the sampling rate of the final MUX to be practically 4 times as high as the carrier frequency [6]. In [6], authors have demonstrated a real-time high-speed SDM reaching 100-GS/s covering the 22.75-27.5 GHz band. However, even higher frequency bands become hardly reachable with this SDoF approach as the state-of-the-art MUXs can no longer provide the required sampling rate. Furthermore, the performance degradation due to jitter and duty-cycle distortions becomes more severe with increasing sampling rate, especially when the sampling rates of the MUXs approach the bandwidth limits achievable with a given semiconductor process [6]. Moreover, the required high sampling rate also poses a strong limitation on the subsequent E/O driver and E/O converter as subsequent stages can hardly provide the required bandwidth to enable the all-digital RoF transmission.

This work also adopts the low-pass sigma-delta modulation (LP- $\Sigma\Delta$) but splits the digital quadrature up-conversion of I/Q signals into two parts: digital up-conversion to the desired carrier frequency and $\pi/2$ phase shifting. In this way, the required sampling rate can be lowered to the Nyquist sampling rate of the desired carrier frequency, i.e. only twice the carrier frequency. This lowers the bandwidth requirements in the MUX, E/O driver, and E/O converter. Moreover, this work maintains the all-digital nature of sigma-delta modulation, which provides robustness against noise and nonlinear impairments from both optical and microwave transmitter components. An in-house developed differential non-return-to-zero (NRZ) driver IC and parallel electro-absorption modulators (EAMs) are employed to further benefit from the sigma-delta-based all-digital transmission, lowering the power consumption and reducing the footprint. The parallel EAMs also provide extra flexibility in terms of gain and phase tuning during signal transmission which can be used to compensate the fiber chromatic dispersion to some extent.

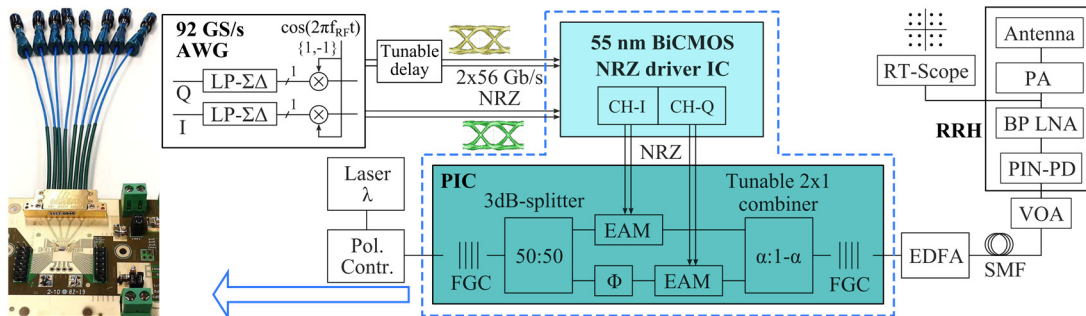

Fig. 1. Block diagram and experimental setup for the sigma-delta radio-over-fiber transmission using parallel EAMs.

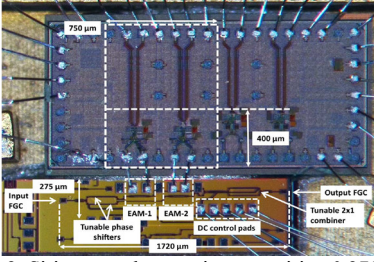

Fig. 2. Si-integrated transmitter, requiring 0.275mm by 1.72mm on PIC and 0.4mm by 0.75mm on EIC, including heaters, bondpads and couplers [7].

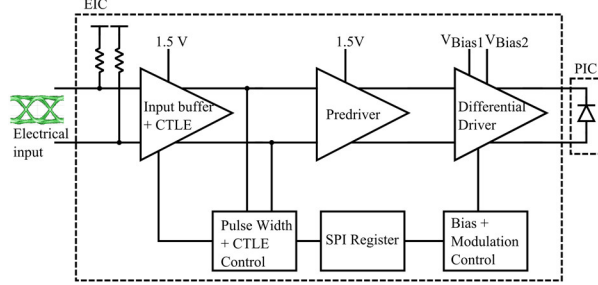

Fig. 3. Block diagram of one channel of BiCMOS EAM driver IC, which biases and drives the EAMs differentially. EIC: electrical integrated circuit. PIC: photonic integrated circuit.

2. Experimental Setup

The experimental setup and its block diagram are illustrated in Fig. 1. A baseband QAM-signal (roll-off 0.28) is first oversampled and noise-shaped by low-pass second-order sigma-delta modulators implemented off-line at an equivalent sampling rate of 56 GS/s for I and Q signals. The generated NRZ bit streams of both I and Q channels are further digitally up-converted to a carrier frequency f_{RF} of 28 GHz by toggling the bits from odd clock cycles, which generates two NRZ streams with equivalent RF signals $I \cos(2\pi f_{RF}t)$ and $Q \cos(2\pi f_{RF}t)$. A 92-GS/s arbitrary waveform generator (AWG) is used to generate two pairs of 200 mVpp sigma-delta modulated NRZ differential signals at 56 Gb/s. A phase shifter of $\pi/2$ at carrier frequency f_{RF} realized by a tunable delay line is utilized to obtain $-Q \sin(2\pi f_{RF}t)$. When the signal bandwidth of interest is small w.r.t. the carrier frequency, the effect of the delay on the I/Q mismatch is negligible. For broader signals, the I/Q mismatch can be easily pre-compensated in the digital baseband.

These NRZ signals are sent through a 6-inch 50 GHz multi-coax connector assembly and RF-transmission lines toward two channels of the EAM NRZ driver IC, which is wirebonded to a printed circuit board (PCB) and to the parallel EAMs (Fig. 2). As shown in Fig. 3, the non-linear EAM driver IC amplifies the input NRZ signals, reversely biases the EAMs and drives them differentially with approx. 2 Vpp. This in-house developed IC is fabricated in a 55 nm SiGe BiCMOS technology [8] and consumes approx. 140 mW for two channels including EAM bias.

The parallel EAMs used for the E/O conversion are very compact GeSi EAMs with >50 GHz bandwidth fabricated on a silicon photonics platform. A 1560 nm 12 dBm external laser is coupled into the PIC through fiber-to-grating couplers (FGCs) with approx. 5 dB loss per coupler. A thermally tunable optical power combiner can resolve the gain mismatch between two EAMs (or I/Q channels). Owing to the digital up-conversion, two EAMs are directly driven by NRZ signals, resulting in a simple RoF transmitter structure. The addition of the two modulated signals will finalize the quadrature up-conversion.

An erbium-doped optical amplifier (EDFA) was used to fix the optical transmit power around 10 dBm and a variable optical attenuator (VOA) was used to control the signal power arriving at a commercial 50 GHz III-V-based 50 Ω PIN-PD at the RRH. A narrowband receiver such as [9] (realized by a bandpass low noise amplifier (LNA) in this work) is preferable as it can help remove the out-of-band quantization noise shaped by the SDMs. The PD and LNA only need to receive the signal of interest around 28 GHz carrier. A Keysight real-time oscilloscope (DSAZ634A) and VSA software were used to demodulate QAM-signals and evaluate the performance.

3. Results and Discussion

The transmitter architecture was first simulated in VPITransmissionmaker software and its equivalent model is shown in Fig. 4. The chirp parameter α_e of the EAMs is unknown. Without loss of generality, the simulation has been carried out for $\alpha_e = 0.5$ and $\alpha_e = -0.5$. For optical back-to-back, the optical phase between the two EAM branches Φ is set to 90° , resulting in the constellation diagram in Fig. 5(a). For both positive and negative α_e , the chromatic dispersion notch can be compensated to some extent by tuning the Φ and the tunable combiner can further compensate the gain mismatch, as shown in Fig. 5(b) and Fig. 5(c).

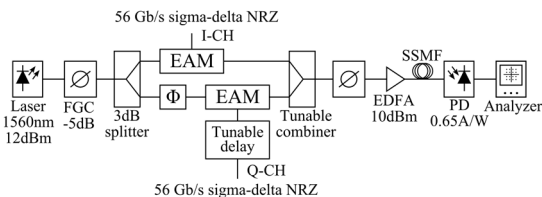

Fig. 4. Overview of the model used in VPITransmissionmaker to simulate the transmitter.

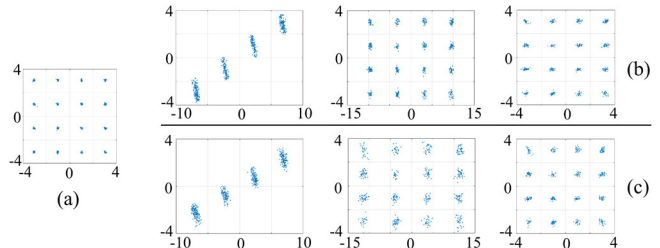

Fig. 5. VPI simulation. (a) 0 km fiber, (b) $\alpha_e = 0.5$, 5.5 km fiber and (c) $\alpha_e = -0.5$, 8 km fiber. $\Phi=90^\circ$ (left), optimized Φ to compensate chromatic dispersion (middle), and jointly optimized combiner ratio and Φ (right).

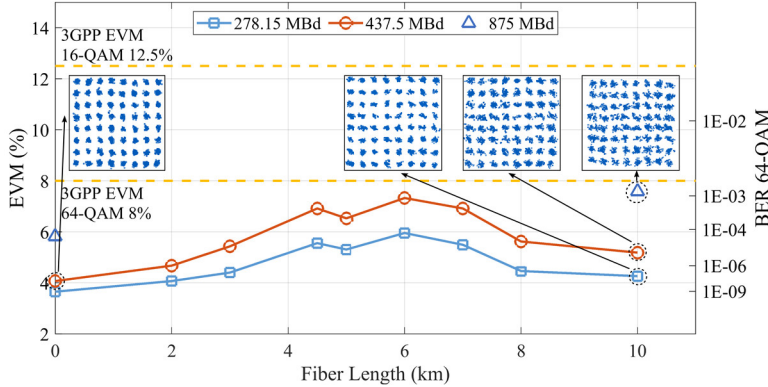

Fig. 6. Measured rms EVM vs fiber spans at 28 GHz carrier frequency.

This experiment was repeated using the proposed assembly. The signal quality was investigated by measuring the root-mean-square (rms) value of the error vector magnitude (EVM). To explore the reach of this SDoF transmission, the EVMs were measured over different fiber spans and compared in Fig. 6. The measured EVMs (at 4 dBm optical received power at PIN-PD) are 3.66% and 4.07% for 278.15 MBd and 437.5 MBd 64-QAM in optical back-to-back (B2B). These EVMs enable adequate signal quality for 64-QAM with $1\text{E-}05$ bit error rates (BERs) before error coding. No noticeable degradation in EVM has been observed for fiber spans below 3 km. It should be pointed out that the EVM degradation caused by the chromatic dispersion notch (for example a distance around 5 km) was compensated by tuning optical phase Φ and the gain using the integrated tunable combiner. For 10 km fiber, the notch is away from the carrier frequency, leading again to a good EVM. Only a small degradation in EVM is observed from optical B2B to 10 km fiber due to increased optical insertion loss. The demodulated constellations of 64-QAM signals are compared in Fig. 6. The total bit rate of the 437.5 MBd 64-QAM signal is 2.625 Gbps and is doubled to 5.25 Gbps when transmitting an 875 MBd 64-QAM signal. As shown in Fig. 7, this all-digital RoF transmitter targets the 5G NR band n257 specified in 3GPP [5] and measured EVMs satisfy the 3GPP requirement for 64-QAM: $\text{EVM} < 8\%$ [10].

The total power consumption of this SDoF transmitter is low, approx. 180mW (excluding laser and AWG, including on-PIC heaters), by avoiding components such as high-speed DACs and frequency up-converters. Besides, the transmitter only requires two 200 mVpp inputs. The high-speed sigma-delta modulator and its parallelization technique from [6] can be employed to replace the AWG. Due to the very compact footprint of the EAMs and NRZ driver IC, it is even feasible to integrate these together with the sigma-delta modulator and MUX into a single module fitting standard pluggable form factor such as QSFP28-compatible.

4. Conclusion

We demonstrated a low-power Si-integrated all-digital radio-over-fiber transmitter for beyond 28 GHz band by using sigma-delta modulation and parallel EAMs, and by splitting the digital quadrature up-conversion. This transmitter architecture halves the required sampling rate and bandwidth in microwave and photonics components compared to prior works, while maintaining the digital nature of sigma-delta modulation. The prominent performance (5.25 Gb/s 64-QAM at 28 GHz carrier over 10 km fiber and wide carrier frequency coverage) corroborates the strong competitiveness of this SDoF approach in high-frequency band radio-over-fiber communications. To the best of our knowledge, it is the first time to realize EAM-based all-digital radio-over-fiber transmission for beyond 28 GHz.

5. Acknowledgement

This work was supported by ERC Advanced Grant ATTO Project (No.695495), H2020 5G-PHOS (No. 761989), and the Research Foundation Flanders (FWO). The authors would like to thank VPIphotonics for the academic license.

6. References

- [1] C. Ranaweera et al., "5G C-RAN with optical fronthaul: an analysis from a deployment perspective," JLT, 2018.
- [2] L. Breyne et al., "Comparison between analog radio-over-fiber and sigma delta modulated radio-over-fiber," PTL, 2017.
- [3] C.-Y. Wu et al., "Real-time 4x3.5 Gbps sigma delta radio-over-fiber for a low-cost 5G C-RAN downlink," ECOC, 2018.
- [4] J. Wang et al., "Delta-sigma modulation for next generation fronthaul interface," JLT, 2019.
- [5] "3GPP Release 15 Overview," [Online]. Available: <https://spectrum.ieee.org/telecom/wireless/3gpp-release-15-overview>.
- [6] H. Li et al., "Real-Time 100-GS/s Sigma-Delta Modulator for All-Digital Radio-over-Fiber Transmission," JLT, 2019 [Early Access].
- [7] J. Lambrecht et al., "Low-Power (1.5 pJ/b) Silicon Integrated 106 Gb/s PAM-4 Optical Transmitter," JLT, 2019 [Early Access].
- [8] H. Ramon et al., "70Gb/s Low-Power DC-Coupled NRZ Differential Electro-Absorption Modulator Driver in 55nm SiGe BiCMOS," JLT, 2019.
- [9] L. Bogaert et al., "Narrowband Photoreceiver for Analog Radio-over-Fiber in the 24.25-29.5 GHz Band," ECOC, 2019.
- [10] 3GPP TS 36.104: "Evolved Universal Terrestrial Radio Access (E-UTRA): Base Station (BS) radio transmission and reception," V15.2.0, 2018-03. (Release 15).

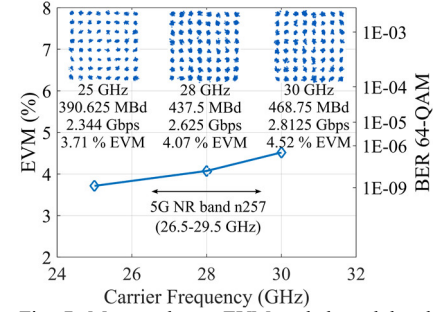

Fig. 7. Measured rms EVM and demodulated constellation vs different carrier frequencies in optical B2B.