

Possibility of obtaining TiO₂ material by plasma dynamic method into an air atmosphere

A A Sivkov, A S Ivashutenko, I A Rakhmatullin, Yu L Shanenkova and Yu N Vympina

National Research Tomsk Polytechnic University, 30 Lenin Ave., Tomsk, 634050, Russia

E-mail: sivkovAA@mail.ru

Abstract. This paper shows the possibility to synthesize directly the titanium dioxide in a supersonic jet of an electric discharge erosive plasma. Using the X-ray diffractometry it is shown that the obtained product contains two main crystalline phases: anatase and rutile with tetragonal syngony. The size of the coherent scattering region is less 100 nm.

1. Introduction

Hydrogen energy is a promising direction for the development of the electric power industry, since it allows obtaining electric energy in an environmentally friendly way with high efficiency. The main limiting factor hindering the introduction of this technology is the low efficiency of hydrogen generation processes as an energy carrier [1]. Along with various existing methods of producing hydrogen, the photocatalytic method is considered to be the most optimal because of its relative economy and low resource consumption [2, 3]. The efficiency of hydrogen production by this method is determined by the properties of the used materials (catalysts), which causes exploratory research in the field of the high-performance catalysts synthesis.

According to the literature [4, 5], titanium dioxide TiO₂ can be used as such materials. The possibility of using titanium dioxide as a photocatalyst is due to its properties, such as: catalytic activity, high stability, low material cost [6–8]. At present, there are several ways to synthesize this chemical compound in a nanoscale state [9], however, most of these methods have considerable time and energy costs. In this paper, the possibility of obtaining ultrafine TiO₂ using a plasma dynamic method. This method is based on a coaxial magnetoplasma accelerator [10]. Unlike existing methods, plasma dynamic synthesis also allows to obtain nanoscale materials, while it is environmentally safe, one-step, fast (less than 10⁻³ seconds) and does not require additional preparation of precursors.

2. Experimental part

The plasma dynamic synthesis is based on the operation of a pulsed high-current coaxial magnetoplasma accelerator with titanium electrodes [11], the sketch-map of which is shown in figure 1. Titanium BT-I-0 is used as electrodes. The power supply of the accelerator is carried out from a capacitive energy storage device with the following operating parameters: charging voltage up to 5.0 kV and capacitor battery capacity up to 28.8 mF.

The process of the experiment begins with charging the capacitive energy storage device to the required voltage U_{ch} . After closing the power switches K, the discharge current of the capacitor



batteries flows along the contour, thereby creating a plasma flow due to the breakdown of the interelectrode gap. During the outflow and acceleration of plasma in the accelerating channel, electroerosion wear of the titanium surface occurs due to high temperatures in places where the arc closes on the surface of the accelerating channel. The material acquired from the accelerating channel surface, being in the discharge current shell, undergoes a change from a solid to a plasma state. At the same time, the material is accelerated to speeds of approximately 5 km/s in the form of a plasma electroerosive jet.

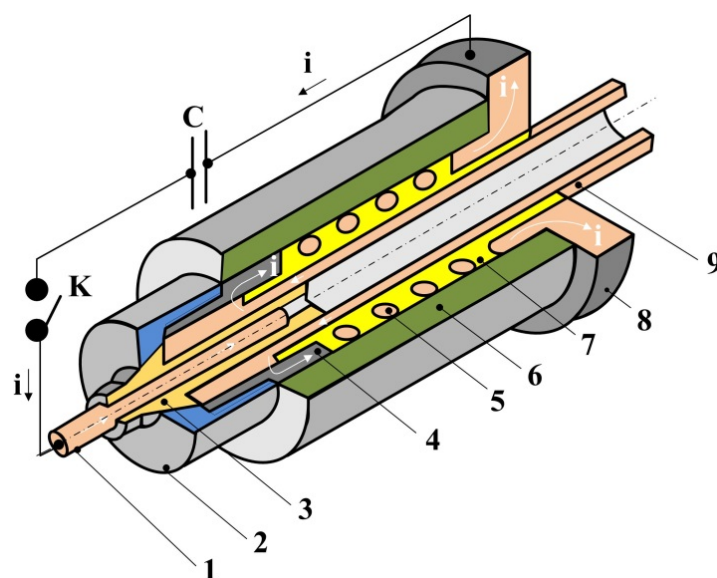

Figure 1. Sketch-map, elements of coaxial magnetoplasma accelerator: 1) central electrode; 2) cap; 3) central electrode insulation; 4) contact cylinder; 5) solenoid; 6) hull; 7) solenoid insulation; 8) contact flange; 9) titanium electrode-barrel.

The plasma dynamic synthesis process of TiO_2 proceeds in the shock wave head of a supersonic plasma jet. In this part of the plasma, the product of synthesis (TiO_2) is sputtered in the liquid phase, and then the process of ultrafine crystalline particles formation proceeds. The hypersonic plasma jet expires in a volume of the sealed chamber-reactor filled with a gaseous mixture (in this experiment, air) at room temperature and a pressure of 1.0 atmosphere. After half an hour it is possible to collect the product of plasma dynamic synthesis. The experiment was carried out with the parameters listed in table 1 (charging capacity C_{ch} , charging voltage U_{ch} , accumulated energy W , internal diameter of the electrode-barrel d , atmosphere in the chamber-reactor, pressure in the chamber-reactor p , room temperature T).

Table 1. Experiment parameters.

C_{ch} (mF)	U_{ch} (kV)	W (kJ)	l (mm)	d (mm)	Atmosphere	P (atm.)	T (°C)
14.4	2.5	45	230	21	Air	1	20

The product of plasma dynamic synthesis without any additional preparation was studied by X-ray diffractometry. Shimadzu XRD-7000S (Cu- K_{α}) equipped with a counting monochromator was used. A full-profile X-ray structural analysis "Powder Cell 2.4" with the structural data base PDF4+ was used too.

3. Results and discussion

Figure 2 shows the X-ray diffraction pattern of the powder obtained by plasma dynamic method. The result of the research showed the presence in the composition of the synthesized product of two modifications of titanium dioxide – tetragonal rutile (rTiO_2) and tetragonal anatase (aTiO_2). The main

crystalline phase is titanium dioxide with rutile modification, the mass content of which is 63%. Anatase mass content is 30%. Also the phase of cubic titanium nitride (cTiN) revealed in the synthesized material. There is reason to assume the presence in the product of other crystalline phases (Ti, TiO, Ti₂O₃), as well as the amorphous phase of TiO₂, but XRD did not show their presence. To clarify the phase composition it is necessary to conduct additional studies.

The formation of titanium nitride and titanium oxides is due to the fact that the experiment was conducted under atmospheric conditions (in air), which contains nitrogen (about 78%) and oxygen (about 21%). Despite the predominance of nitrogen, the titanium nitride mass content in the product of plasma dynamic synthesis is only 7%. This is due to the fact that the formation of metal oxides occurs at lower energy costs (due to the higher electronegativity of oxygen compared to nitrogen [12]).

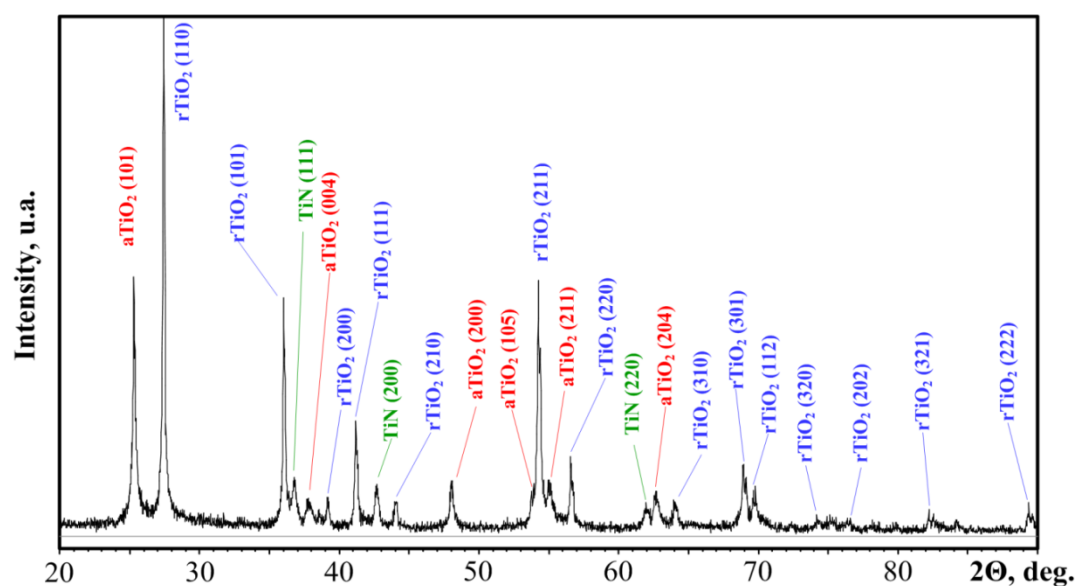

Figure 2. X-ray diffractogram of a powder product obtained by plasma dynamic synthesis.

Anatase is often considered the most photocatalytically active phase of TiO₂, but the simultaneous presence of rutile and anatase crystalline modifications is more active [13, 14]. However, titanium dioxide shows its activity only under the action of ultraviolet radiation [15–17]. To drift the absorption spectrum of titanium dioxide to the visible region, this compound is doped with nitrogen atoms or treated with nitrogen-containing compounds [18, 19]. Due to this fact, it can be assumed that the presence in the synthesized product of rutile and anatase modification, as well as titanium nitride, can positively affect its photocatalytic properties.

Table 2. Main data of full-profile structural phase analysis of the synthesized product.

Phase	Content (% mass.)	CSR (nm)	$\Delta d/d \times 10^{-3}$	Lattice parameters experimental/PDF	
				a	c
cTiN	7	–	–	4.2375/4.2410	–
rTiO ₂	63	69.66	0.407	4.6006/4.5940	2.9653/2.9590
aTiO ₂	30	50.21	3.350	3.7899/3.7970	9.5248/9.5790

Table 2 presents the results of X-ray phase analysis. The lattice parameters of the synthesized material deviate from the standard values, which, apparently, can be explained by some imperfection of the material structure. The presence of defects is due to a nonequilibrium synthesis process and a

high crystallization rate. The size of the coherent scattering regions (CSR) is less than 100 nm, therefore that this material is nanostructured.

4. Conclusion

The work shows the possibility of obtaining a dispersed titanium dioxide powder by the plasma dynamic method using a system based on a coaxial magnetoplasma accelerator with a titanium accelerator channel.

Results of X-ray diffraction analyze showed the presence in powder of two main crystalline modifications of titanium dioxide: rutile with tetragonal syngony and anatase with tetragonal syngony. Also cubic titanium nitride was found. The presence of this binary chemical compound is determined by the conditions of the experiment. The structures obtained in the process of plasma dynamic synthesis have some level of imperfection. This fact can positively affect the catalytic activity of the synthesized materials. The size of coherent scattering regions is less than 100 nm, therefore, presumably, the powder product is nanoscale.

References

- [1] Shiva Kumar S and Himabindu V 2019 *Mater. Sci. for En. Tech.* **2** 442
- [2] Chiarello G L, Dozzi M V and Selli E 2017 *J. of En. Chem.* **26** 250
- [3] Mazierski P, Mikolajczyk A, Bajorowicz B, Malankowska A, Zaleska-Medynska A and Nadolna J 2018 *Appl. Catal. B: Envir.* **233** 301
- [4] Carp O, Huisman C L and Reller A 2004 *Prog. In Solid State Chem.* **32** 33
- [5] MirAlipour S, Friedmann D, Scott J and Amal R 2018 *J. Hazard Mater.* **341** 404
- [6] Fujishima A, Zhang X and Tryk D A 2008 *Surf. Sci. Rep.* **63** 515
- [7] Lee S-Y and Park S-J 2013 *J. of Indust. and Engin. Chem.* **19** 1761
- [8] Chung I and Lee B 2012 *Nat.* **485** 486
- [9] Velázquez-Martínez S 2018 *J. Photochem. Photobiol. A Chem.* **359** 93
- [10] Kuzenov V V, Polozova T N and Ryzhkov S V 2015 *Probl. Atomic Science Technology* **4** 49
- [11] Sivkov A A, Gerasimov D Yu and Nikitin D S 2017 *Tech. Phys. Lett.* **43** 16
- [12] Luo Q-G and Wang R-Y 1987 *J. Phys. Chem. Solids* **48** 425
- [13] Soboleva N M 2007 *Himiya I tehnologiya vody* **29** 125
- [14] Krasil'nikov V N 2013 *Fizika tverdogo tela* **55** 1788
- [15] Abdullah H, Rahman Khan Md M and Ruey Ong H, Yaakob Z 2017 *J. of CO2 Utiliz.* **22** 15
- [16] Mao H, Fei Z, Bian C, Yu L and Chen S 2019 *Ceram. Inter.* **45** 12586
- [17] Chang L-H and Cho C-P 2019 *Mater. Chem. And Phys.* **223** 683
- [18] Stroyuk A L, Kryukov A I and Kuchmij S Ya 2010 *Nanosystems, Nanomaterials, Nanotechnologies* **8** 1
- [19] Livraghi S, Chierotti M R, Giamello E, Magnacca G, Paganini M C, Cappelletti G and Bianchi C L 2008 *J. Phys. Chem. C* **112** 17244