

1st Mediterranean Young Geotechnical Engineers Conference
23-24 September 2019, Mugla, Turkey

NUMERICAL EVALUATION OF THE PIPE-PILE BUCKLING DURING VIBRATORY DRIVING IN SAND

Montaser Bakroon*, *Chair of Soil Mechanics and Geotechnical Engineering, Technische Universität Berlin, m.bakroon@campus.tu-berlin.de*

Reza Daryaei, *Chair of Soil Mechanics and Geotechnical Engineering, Technische Universität Berlin, r.daryaei@campus.tu-berlin.de*

Daniel Aubram, *Chair of Soil Mechanics and Geotechnical Engineering, Technische Universität Berlin, daniel.aubram@tu-berlin.de*

Frank Rackwitz, *Chair of Soil Mechanics and Geotechnical Engineering, Technische Universität Berlin, frank.rackwitz@tu-berlin.de*

ABSTRACT

The buckling of steel pipe piles during vibratory driving is numerically studied using the Multi-Material Arbitrary Lagrangian-Eulerian (MMALE) method. This method handles the large soil deformations that occur during pile driving and other geotechnical installation processes. The Mohr-Coulomb and an elastic-perfectly plastic material model are used to model the soil and the pile mechanical behavior, respectively. The result of a small-scale pile driving experiment is used to validate the numerical model. The penetration trend agrees well with the experimental measurements. Thereafter, four case scenarios and their possible effects on pile buckling, namely the presence of heterogeneity in the soil (a rigid boulder inside the soil) and the existence of geometrical imperfection modes in the pile (ovality, out-of-straightness, flatness) are investigated. This study shows that a combination of local and global buckling initiates at the pile tip and the pile shaft, respectively. During the initiation of buckling, a decrease in the penetration rate of the pile is observed compared to the case where no or minimal buckling occurs. It is shown that a less portion of the driving energy is spent on the pile penetration and the rest is spent on other phenomena such as buckling, resulting in less pile penetration. The cross section of the pile tip after buckling takes a form of a “peanut”, yet with a different geometry for each case. In cases where the model was initially symmetric, an asymmetric shape in cross section of the pile tip was obtained at the final stage which can be attributed to complex soil-structure interaction. The results of the numerical approach provide promising results to be used as an evaluation tool to reach reliable predictions in pile installation practice.

Keywords: Pipe-pile buckling, Imperfection, Pile installation, Soil-structure interaction, Multi-Material Arbitrary Lagrangian-Eulerian, Large deformations

1. INTRODUCTION

One of the dominant pile failure modes is pile buckling where a sudden increase in pile deformation is observed. Buckling usually occurs in slender structures subjected to an axial compressive force as a mechanical instability. It is mostly investigated in the field of structural and mechanical engineering but not thoroughly in geotechnical engineering. The focus of this study is the evaluation of pile buckling during the installation process of the pile. Several scenarios are considered such as the presence of heterogeneity in the soil and penetration using initially imperfect piles. In the literature regarding pile buckling, the support condition of the

pile is idealized, i.e., the pile is considered either with no lateral supports or as completely embedded (“wished-in-place”) without simulation of the installation process. However, as the pile penetrates during installation, lateral support from the soil evolves because of its particular nonlinear, path-dependent mechanical behavior. Therefore, the pile can be divided into two distinct parts with different buckling characteristics, namely, an embedded part and an upper part which is not yet laterally supported. The motivation of this study is to investigate buckling during the installation process under semi-embedded pile condition which is frequently observed in offshore geotechnical engineering.

Conventionally, buckling is classified into two main groups: Global buckling and local buckling. In global buckling, the pile deforms somewhat similar to the Euler’s buckling problem mainly due to an instability associated with the axial load and the pile as a whole. In local buckling, on the other hand, significant permanent deformations occur in the cross-section of the pile with no direct correspondence to an overall instability [1].

The global buckling phenomenon in geotechnical engineering design codes for pile performance is characterized by defining a critical stress/load depending on the slenderness ratio (Length/radius of gyration) and structure stiffness as well as the soil stiffness [1]. In contrast, the local buckling is generally characterized as localized damage which is often encountered at the pile tip (so-called pile tip buckling) and can occur at any stage of driving to the pile. Several reasons are suggested in the literature for the local buckling including initial pile imperfection, soil heterogeneity, induced forces from the soil, etc. Increased driving resistance, pile deviation from its longitudinal axis, and different pile response against lateral loads are some of the effects of the local buckling [2].

The local or pile tip buckling was observed in several offshore practices such as the pile installation project is the Goodwyn-A platform construction project in Australia. It was reported that the occurrence of local buckling caused many piles to fail during installation [3].

Due to many challenges to evaluate the pile installation on-site, the numerical simulation of such processes has gained attention during the last decades. However, the simulation of pile installation has posed several challenges, which generally involve large deformations and material flow when conventional numerical methods are used.

In this study, a robust numerical approach is suggested facilitating the study of pile buckling during installation in the soil. By using this method, the occurrence of local buckling can be observed due to various scenarios such as initial pile imperfection. To the best knowledge of the authors, numerical evaluation of buckling behavior of perfect or imperfect piles during installation in soil has not been extensively studied in the literature.

The structure of the paper is as follows: in section 2, a brief description of the employed numerical method, the developed numerical model, as well as its validation against the experiment is presented. In section 3, the results of the different scenarios are shown and discussed. The concluding remarks are presented in section 4.

2. METHODOLOGY

2.1 Description of the MMALE method

Pile installation belongs to the group of large deformation problems, the numerical analysis of which via the conventional numerical approaches is often challenging [4]. Concerning methods which are capable of handling such problems, one of the most promising approaches is the Multi-Material Arbitrary Lagrangian-Eulerian (MMALE) method [5].

The general strategy of MMALE is to generate a mesh not necessarily aligned with material boundaries. Therefore, a number of so-called multi-material elements might be present holding a mixture of two or more materials. A zone free of any material known as the void zone with neither mass nor strength must be introduced in the mesh. Such zones are essential for non-Lagrangian calculation step to capture material flow into initially unoccupied (i.e., void) regions of the physical space. After one or several Lagrangian steps are performed, a new arbitrary mesh is developed which may not be identical to the initial mesh configuration (rezoning/remeshing step). Subsequently, the solution is transported from the previous mesh to the new mesh (remapping/advection step). The sub-steps are not performed in parallel but in a sequential routine using the operator-splitting technique [5], [6].

Despite its popularity in fluid dynamics and computational physics, the MMALE application in geotechnical problems is limited. A series of works conducted by Bakroon et al. [7], [8] assesses the capabilities of MMALE in the simulation of complex large deformation problems. Compared to classical Lagrangian methods, the MMALE showed promising performance.

2.2. Soil-structure interaction

The penalty contact scheme is employed in the numerical model where the momentum is maintained [9]. The contact force is measured based on the arbitrary penetration of the parts. This is considered by adding a penalty term to the energy equation as follows [10]:

$$\Pi = E_p + E_k + \frac{1}{2} k \Delta u^2 \quad (1)$$

Where E_p and E_k are potential and kinetic energy, respectively, k is the spring stiffness representing the contact interface, and u is the arbitrary penetration of two contact parts.

2.3 Description of the model

A model based on MMALE formulation is developed, where a pile is installed in the soil using vibratory force. The model has been developed to back-calculate a small-scale experimental test at TU Berlin. The model configuration and the load history curve is shown in Figure 1a and Figure 1b, respectively.

The pile has 1.5 m height, 0.2 m diameter, and 0.005 m thickness. The conventional shell element formulation with reduced integration point is used. A uniform element size of 2-cm is assigned. An elastic-perfectly plastic material model based on von Mises failure criterion is used (see Table 1).

Table 1. General properties of the pile used in benchmark models

Density ρ (kg/m ³)	Elastic Modulus E (MPa)	Yield Stress σ_y (MPa)	Poisson ratio ν	Thickness t (m)	Radius R (m)
7850	2.1E5	250	0.3	0.005	0.1

Table 2. Mohr-Coulomb material constants for Berlin sand [11]

Density ρ (kg/m ³)	Friction angle ϕ	Dilatancy angle ψ	Cohesion c (MPa)	Poisson ratio ν	Elastic Modulus E (MPa)
1900	35°	1°	0.001	0.2	20

For the soil, a mesh with 2 m height and 1 m radius with the one-point integration MMALE element formulation is generated. A mesh, with varying element width from 0.6 – 8 cm is used in the horizontal direction, whereas a uniform mesh in the vertical direction with 2.5 cm is

considered. The mesh is filled with the soil up to the height of 1.8 m. The rest is kept as unfilled/void domain above the soil material to enable the soil to move to this domain after penetration starts. The Berlin sand is used with the Mohr-Coulomb constitutive equation parameters listed in Table 2. The initial stress in the soil is defined with assigning the gravity acceleration as 10 m/s^2 .

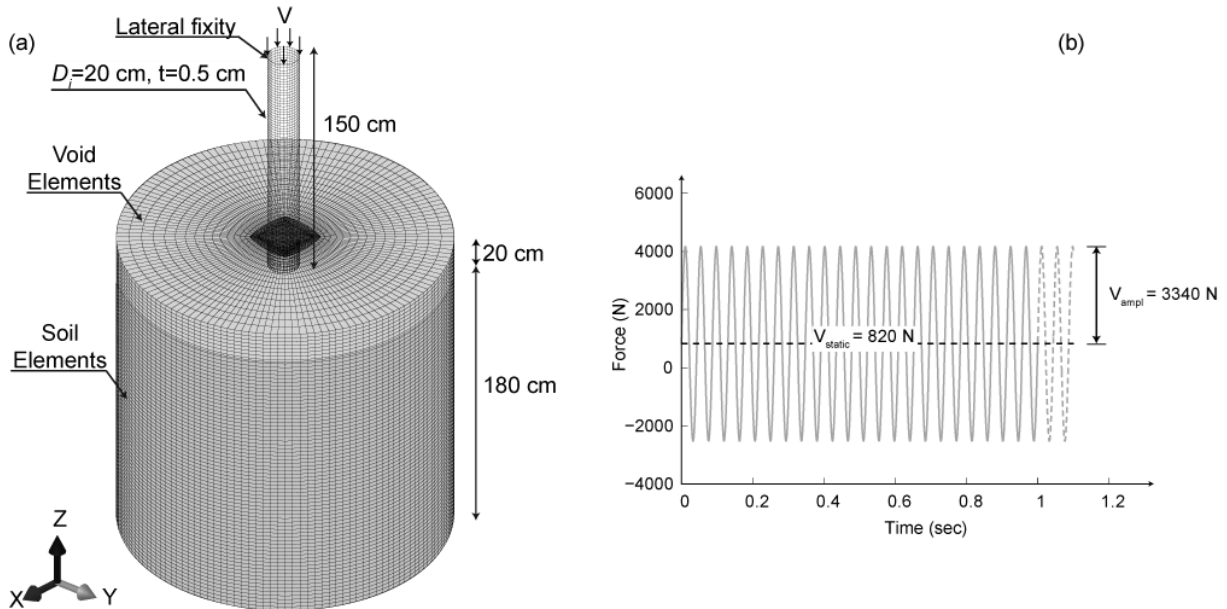

Figure 1. Schematic diagram of the (a) isometric view of the numerical model configuration and (b) vibratory load history curve

A penalty contact with a tangential friction coefficient of 0.1 is defined. The pile is fixed at the top against horizontal movements. Conventional fixities are applied to the soil boundary.

2.4 Validation against experimental results

The proposed numerical model is validated against a small-scale experimental test conducted at the laboratory of the Chair of Soil Mechanics and Geotechnical Engineering at Technische Universität Berlin (TU Berlin). The test consists of a half-cylindrical pile with 1.5 m length, 0.005 m thickness, and 0.2 m outer diameter placed above the Berlin sand. Using pile guides, the pile is constrained in the horizontal direction. A vibratory motor with the driving force of 1670 N using the frequency of 23 Hz is employed. The mounting parts and the motor weigh about 410 N.

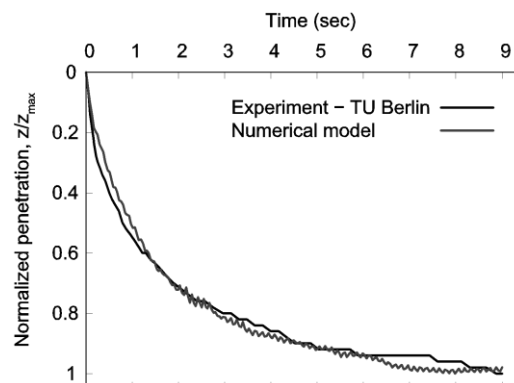

Figure 2. Penetration depth vs. time curve obtained from the numerical model and experimental measurement

A quarter model is developed based on the descriptions in section 2.3, with assuming the pile acting as a rigid part. Figure 2 shows the pile displacement curve from the numerical model compared with experimental measurement. Since the focus of this study is to reach the same penetration trend, the curves are normalized by their maximum value. The numerical result is in good agreement with the one measured in the experiment. Initially, the penetration rate is significant due to less soil resistance and confining pressure. Subsequently, the confining stress in the soil around the pile skin increases, causing an increase of the frictional force and thus a decrease in the penetration rate.

The vertical and horizontal stress contours at the designated time during the vibratory loading is shown in Figure 3. The areas around the pile are disturbed during the installation up to a distance horizontal distance of $2D$, where D is the pile diameter (Figure 3a). In a lateral distance far enough from the pile, say $5D$, the lateral stress in the soil reaches its in-situ value, which verifies that the boundary distance is far enough from the dynamic source to have substantial effects. A relatively large vertical stress is noted in the soil under the pile tip until the depth of $4D$ (Figure 3b). At a depth of about $6D$ from the soil surface, the stress isolines become almost horizontal, determining the influence region of the vibration caused by driving which is reasonably far from the boundary.

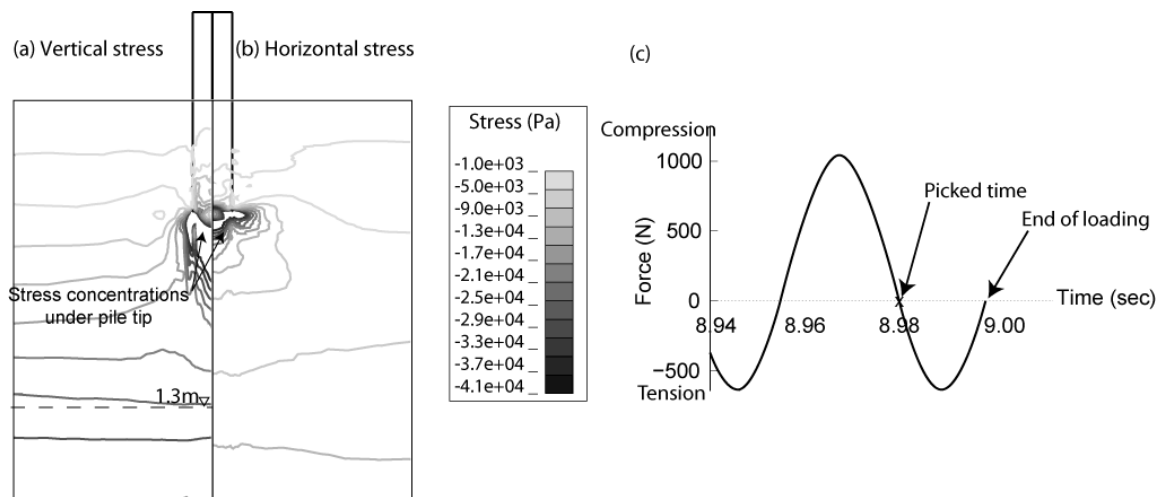

Figure 3. Isolines of the induced (a) vertical and (b) horizontal stress in the soil, and (c) the corresponding loading at 8.98 sec

3. RESULTS AND DISCUSSION

In this section, the pile buckling phenomenon during installation is evaluated by using the model described in section 2.3. Here, five different scenarios are presented. In the first case, a model is developed the pile is geometrically assumed perfect. This case is referred to as the reference model. In addition, three models are developed where the pile initially holds an imperfection, namely a pile with an oval shape in cross-section, a flat side, and out-of-straightness. In the last case, heterogeneity is introduced by defining a boulder in the soil. To reach a more noticeable buckling in the model after a short amount of penetration, a lower elastic modulus (1% of the one in Table 1) was assigned to the pile.

The comparison criteria are the mean strain, internal energy, and load-penetration curve. The mean strain is defined as one-third of the strain tensor trace based on the infinitesimal theory. The internal energy is defined as the work done to induce strain in a unit volume of the shell part (taking into account the shell thickness). This criterion is used here to evaluate the accumulated strain in a pile during installation.

In Figure 4a, the vertical displacement of the pile head is plotted against time. In the case of the reference model, the pile did not exhibit any significant buckling until about 8 seconds of the simulation or 0.65 m penetration depth. Afterward, a localized buckling was observed. The other four models (ovality, flatness, straightness, and heterogeneity), the final penetration is less than the reference model. Initially, the penetration rates are mostly identical. In case of heterogeneity, the penetration rate decreases significantly after it hits the boulder at 1.5 seconds. The final depth of this case is half of the reference model. After about 2 seconds, the penetration rate of the oval-shaped pile starts to decrease as well. In the case of the other two imperfect piles, namely the piles with flatness side and out-of-straightness, the penetration rate decrease at the same time after about 4 seconds.

In Figure 4b, the accumulated internal energy for all cases is plotted. Knowing that the same driving force was used for all models, one can conclude that the same driving energy is utilized in all models. According to the energy conservation law, this energy must have been spent on other phenomena such as additional strains and/or buckling in the pile. Therefore, to assess this point, the internal energy of each pile, is compared in Figure 4b. The curves in are cut to the value of 40 J. In case of a further increase in energy curve, a cross sign is replaced. In all cases, as the penetration curve deviates from the reference model, the corresponding internal energy of the pile starts to increase considerably. Thus, the remaining driving energy is spent on buckling. On the other hand, a decrease in the internal energy value is noticed after significant jumps in some cases which can be attributed to the induced elastic strains in the pile which after further penetration the pile springs back elastically. The possibility of the occurrence of this behavior has also been reported by Aldridge et al. [2]. As a result, it can be argued that the driving energy for the pile installation is reflected in the model in other forms, such as pile buckling.

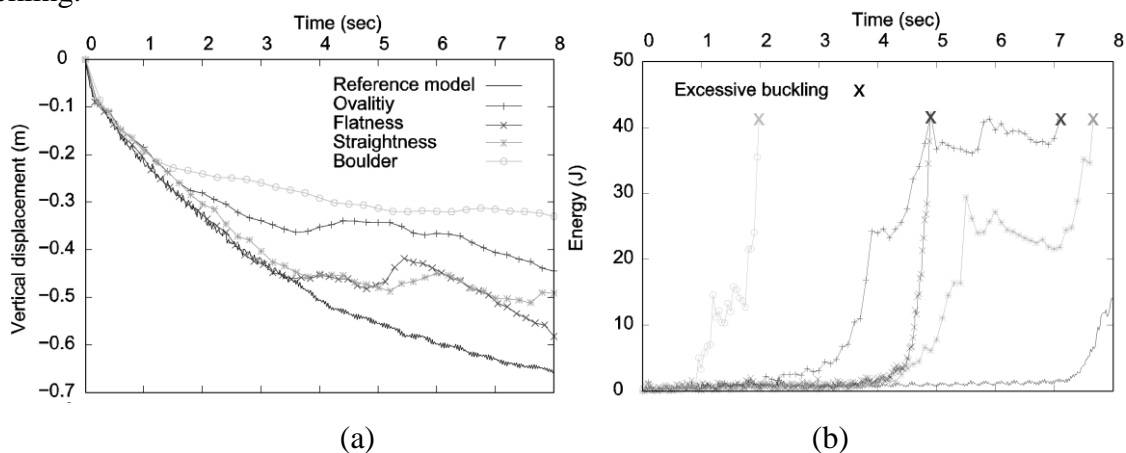

Figure 4. Comparison of the imperfect piles with the reference model based on the (a) vertical displacement (b) the internal energy

The deformed shape of the pile in length and pile tip section and the mean strain contour plots are shown in Figure 5. The results correspond to the time stamps, where maximum internal energy was measured. In the case of the reference model, a minor strain is induced in the pile which is less than 0.05%. Also, the initial cross-section is maintained during the penetration.

In comparison to the reference model, a relatively significant strain/buckling is induced by the piles in the models, which is mostly accumulated at the pile tip. This points out the parts where the pile is damaged. Furthermore, the progressive pile deformation is non-symmetric even for the case of ovality and reference model where the piles have an initial symmetric shape. Besides, each model shows a different buckling mode due to the different initial condition. Also, the cross sections of the pile tip in the studied cases tend to contract in one side direction

and take a so-called “peanut-shaped”. This phenomenon has also been reported in the literature [2], [3].

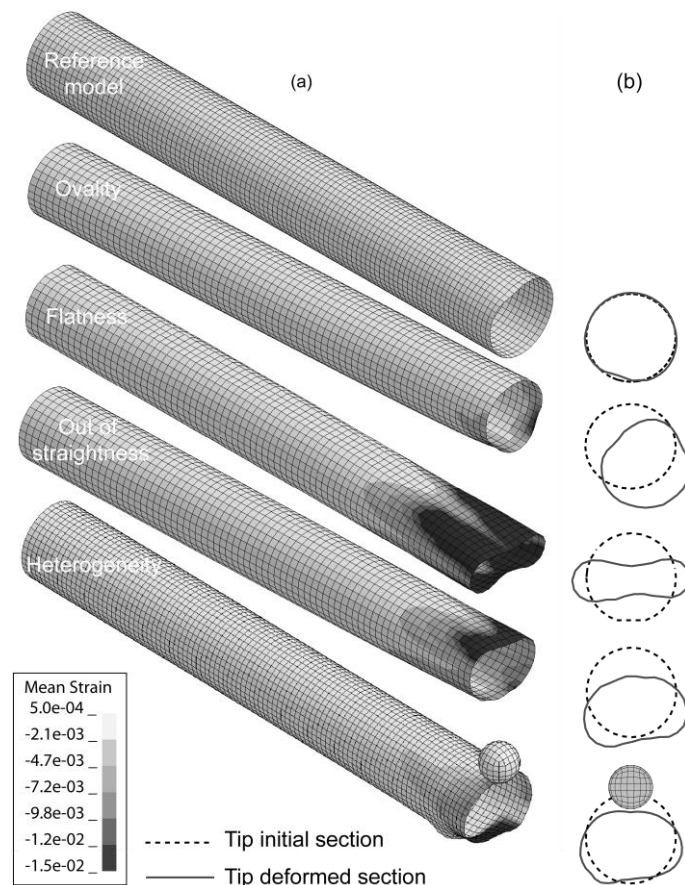

Figure 5. (a) Contours of induced mean infinitesimal strain in the imperfect piles and the reference model and (b) the pile tip cross section compared to its initial

Concerning the above discussion, the proposed numerical model is shown to consider the complex site conditions such as the effects of soil resistance, pile imperfection, and heterogeneity during pile driving. In addition, the model provides reliable measures to assess pile buckling.

4. CONCLUSION

The focus of this study is to evaluate pile buckling during pile driving taking various complex conditions into account, such as the presence of heterogeneity in the soil and existence of initial geometrical imperfections in the pile. To this extent, a robust MMALE numerical approach, in conjunction with a soil-structure interaction scheme, was used to improve the numerical analysis of pile buckling during the installation process.

The results are compared to a reference model where the pile has a perfect cylindrical shape with no heterogeneity in the soil. The buckling modes varied for each scenario. Interestingly, before the initiation of a significant buckling, a decrease in the penetration rate was observed. Simultaneously, the internal energy started to increase. This study shows that the driving energy used for pile driving is consumed on other phenomena such as pile buckling. Consequently, less penetration will be observed in the case of buckling. The initial imperfection not only accelerates the buckling process but also changes the buckling mode of the pile.

The presented work focused on a specific area, i.e. pile imperfection and soil heterogeneity. There are numerous affecting parameters on pile buckling which cannot be summarized in one study. Following points may also be considered in future works:

- Evaluation of the effects of varying pile thickness in length on reducing the buckling
- Determination of the occurrence of the plugging during installation
- Evaluation of the pile bearing capacity

ACKNOWLEDGMENT

The authors are thankful for the partial financial support obtained from Deutscher Akademischer Austauschdienst (DAAD) with grant number 91561676 and the Elsa-Neumann scholarship of city Berlin (NAFOEG) with grant number T68001.

REFERENCES

- [1] DIN EN 1993-1-6:2007, *Design of steel structures - Part 1-6: Strength and stability of shell structures*, Eurocode 3. 2007.
- [2] Aldridge, T. R., T. M. Carrington, and N. R. Kee, “*Propagation of pile tip damage during installation*,” *Frontiers in Offshore Geotechnics, ISFOG 2005 - Proceedings of the 1st International Symposium on Frontiers in Offshore Geotechnics*, pp. 823–827, 2005.
- [3] Kramer, G., “*Investigation of the Collapse Mechanism of Open Ended Piles during Installation*,” TU Delft, 1996.
- [4] Bakroon, M., R. Daryaei, D. Aubram, and F. Rackwitz, “*Arbitrary Lagrangian-Eulerian Finite Element Formulations Applied to Geotechnical Problems*,” in *Numerical Methods in Geotechnics*, J. Grabe, Ed. Hamburg, Germany: BuK! Breitschuh & Kock GmbH, 2017, pp. 33–44.
- [5] Benson, D. J., “*Computational methods in Lagrangian and Eulerian hydrocodes*,” *Computer Methods in Applied Mechanics and Engineering*, vol. 99, no. 2–3, pp. 235–394, 1992.
- [6] Aubram, D., F. Rackwitz, and S. A. Savidis, “*Contribution to the non-lagrangian formulation of geotechnical and geomechanical processes*,” in *Lecture Notes in Applied and Computational Mechanics*, vol. 82, Springer International Publishing, 2017, pp. 53–100.
- [7] Bakroon, M., R. Daryaei, D. Aubram, and F. Rackwitz, “*Multi-Material Arbitrary Lagrangian-Eulerian and Coupled Eulerian-Lagrangian methods for large deformation geotechnical problems*,” in *Numerical Methods in Geotechnical Engineering IX: Proceedings of the 9th European Conference on Numerical Methods in Geotechnical Engineering (NUMGE 2018)*, 2018, pp. 673–681.
- [8] Bakroon, M., R. Daryaei, D. Aubram, and F. Rackwitz, “*Implementation and Validation of an Advanced Hypoplastic Model for Granular Material Behavior*,” in *15th International LS-DYNA® Users Conference*, 2018, p. 12.
- [9] Hallquist, J., *LS-DYNA® theory manual*, no. March. California: Livermore Software Technology Corporation, 2006.
- [10] Wriggers, P., *Computational contact mechanics, second ed.*, Springer. 2006.
- [11] Schweiger, H. F., “*Results from numerical benchmark exercises in geotechnics*,” in *5th European Conference on Numerical Methods in Geotechnical Engineering (NUMGE 2002)*, P. Mestat, Ed. Paris, 2002, pp. 305–314.