



## An Analytical Cost Estimation Approach for Generic Sheet Metal 3D Models

Marco Mandolini<sup>1</sup> , Claudio Favi<sup>2</sup> , Michele Germani<sup>3</sup> , Marco Marconi<sup>4</sup> ,  
and Roberto Raffaelli<sup>5</sup> 

<sup>1</sup>Università Politecnica delle Marche, [m.mandolini@univpm.it](mailto:m.mandolini@univpm.it)

<sup>2</sup>Università degli Studi di Parma, [claudio.favi@unipr.it](mailto:claudio.favi@unipr.it)

<sup>3</sup>Università Politecnica delle Marche, [m.germani@univpm.it](mailto:m.germani@univpm.it)

<sup>4</sup>Università degli Studi della Tuscia, [marco.marconi@unitus.it](mailto:marco.marconi@unitus.it)

<sup>5</sup>Università degli Studi eCampus, [roberto.raffaelli@uniecampus.it](mailto:roberto.raffaelli@uniecampus.it)

Corresponding author: Marco Mandolini, [m.mandolini@univpm.it](mailto:m.mandolini@univpm.it)

### ABSTRACT

This paper defines a systematic workflow for production cost estimation of sheet metal stamped components. The approach represents a solution toward the adoption of Design to Cost methods during early product design. It consists in a sequence of steps that, starting from a 3D CAD model with annotations (material, roughness and tolerances) and production information (batch and production volume) leads to the manufacturing cost through an analytic cost breakdown (raw material, stamping and accessory processes, setup and tooling). The calculation process mainly consists in a first step where geometric algorithms calculate the sheet metal blank (dimensions, shape, thickness) and specific product features (e.g. flanges, louvers, embossing, etc.). The following steps allow to calculate the raw material, the stamping process and the process-related parameters, which are the manufacturing cost drivers (e.g. press, stamping rate/sequence/force and die dimensions/weight). The manufacturing cost is the sum of the previous calculated items. Testing the approach for three different components, the average absolute deviation measured between the estimated and actual cost was less than 10% and such a result looks promising for adopting this method for evaluating alternative design solutions.

**Keywords:** Design to Cost, Feature Recognition, Sheet Metal Stamping, Cost Estimation.

**DOI:** <https://doi.org/10.14733/cadaps.2019.936-950>

## 1 INTRODUCTION AND RELATED WORKS

Global competition forces industrial companies to accurately monitor production costs during all the phases of the design process [23]. The prediction of cost for part production is considered an essential factor for the commercial success of products [11]. For this reason, Design to Cost (DtC) and cost estimation are currently becoming key design activities to pursue the most convenient production strategy and thus to guarantee producibility and economic sustainability for new products [2][14]. It is essential to provide designers with tools and methods for assessing product costs during the early stages of the design process, when there are the necessary degrees of freedom to change critical product features towards economic savings [17].

Considering the industrial products, sheet metal stamped components play a very important role, since they are largely used in several industrial sectors, especially automotive and household appliances industries. This is mainly due to the ease to obtain final components with the desired shape and appearance by using quite simple tools [4]. In this context, the estimation of production costs is mostly based on the formalization and reuse of the company past experiences. For instance, Naranje and Kumar [13] and Tor et al. [20] defined two different knowledge-based approaches for process planning and die design, which represent two fundamental tasks for an effective cost estimation of stamped components. Karadgi et al. [6] presented a case-based reasoning methodology to determine process plans and estimate production costs of complex sheet metal products. To avoid the need of preliminary extensive process planning, Verlinden et al. [21] used artificial intelligence, neural networks and regression techniques to define cost estimation formulas. Generally, the cost estimation methods based on company knowledge and data collected during past experiences suffer from the following drawbacks:

- they are not sufficiently accurate and reliable, since the estimation process is not based on the analytical calculation of a sequence of operations starting from the product features, but only on “similarities” among the current and previous cases;
- they require the availability of huge amounts of data. For instance, the use of techniques based on neural networks requires the availability of “big data” to be used during the learning phase for the optimization of weights in the network;
- they strictly depend from the application context. For the correct behavior of a knowledge-based or artificial intelligence system, the knowledge and data gathered in a company should be as specific as possible and cannot be easily reused in other companies; thus, an initial long and complex data gathering and classification phase is required for each application.

Cost estimation based on analytical approaches seems to be the most interesting solution to solve the abovementioned issues. Those methods are grounded on the determination of the economic value of a product by considering the manufacturing process for transforming a raw material in the final product. They allow designers to easily find economical criticalities of a product and evaluate how its features (i.e. material, dimension and shape) affects the manufacturing cost. In addition, analytical methods are based on standard data (e.g. standard raw material properties, standard machines, standard parameters) that can be stored in dedicated databases and used for the estimation. In this case, only a “light” customization is generally required for each application (e.g. addition of new machines, change of technological parameters, change of a rules).

An analytical and accurate cost estimation approach requires the definition of relevant technological parameters (e.g. die dimension and typology, stamping sequence, press parameters), as well as the identification and use of design and geometric drivers or features (e.g. blank shape and dimensions, embossing, louvers, tolerances) [12][15][19]. Features are generally defined as aggregate of entities derived from standard 3D models to support the process and assembly planning [5]. In the last decades, several literature studies have been focused on the development of automatic feature recognition algorithms, mainly to efficiently extract information from CAD models to be reused in CAM or CAPP applications [3]. In the context of sheet metal components, one of the most complex and interesting topic regards the surface flattening and the recognition of features from freeform surface CAD models [1][18]. Literature studies, focused on the generation of 2D flat

patterns from triangulated 3D surfaces are grounded on different methods. Zhong and Xu [24] developed a physically based method to unfold winged triangles that share the same edges and successively flatten the surface. Li et al. [7] defined a flattening algorithm using a planar triangular mass-spring model based on methods used for cloth simulations. Several authors, instead, investigated the application of methods based on energy model [8][9][10][16][22], which is the most common and effective method to transform a 3D freeform surface in a 2D flat surface.

This paper wants to contribute to the state of the art in the cost estimation topic, by defining a systematic workflow for calculating the production cost of sheet metal stamped components. The proposed analytical cost estimation approach is based on the information extracted from the 3D CAD model by feature recognition techniques. This approach allows the recognition of relevant geometrical parameters needed for the calculation of technological parameters, and, finally, for the estimation of costs related to raw material, stamping process, accessory processes and setup.

The cost estimation method represents a useful tool to quantitatively support designers in comparing different feasible alternatives and to guide the decision-making process toward the minimization of production costs. The method presented in this paper encompasses sheared/bended parts, even characterized by non-developable surfaces. Deep drawing features, relative to a cluster of drawn surfaces whose deformation depth exceeds the diagonal of the relative flattening, are not managed.

The rest of the paper is organized as follows. Section 2 describes the proposed cost estimation approach by providing details regarding both the feature recognition algorithm, needed to extract relevant product features, and the cost parameters and formulas. Section 3 presents the results of the approach experimentation, carried out by using three sheet metal components of different complexity. Finally, Section 4 discusses strength, weaknesses, conclusions and proposals for future developments.

## 2 MATERIAL AND METHODS

The proposed cost estimation approach consists of two main steps. The first one, described in section 2.1, aims to analyse the 3D CAD model with annotations (tolerances and roughness) for determining the sheet metal stamping cost drivers, which refer to the blank (thickness, bounding box dimensions, area and perimeter) and local features (louvres, dimples, bends, flared holes and darts) with related information (size, perimeter, area and type). The second step, detailed in section 2.2, aims to calculate the cost of a stamped component (raw material, labour, stamping and accessory processes and setup). The application of the overall process is based on an initial evaluation of a design engineer or cost engineer. The component is processed if it does not contain deep drawing features (see the definition provided in section 1), otherwise the cost estimation algorithm would be affected by high inaccuracies. In fact, the presented cost estimation approach does not account the deep drawing energy, required press tonnage, as well as other related process parameters (e.g. maximum strain ratio).

### 2.1 Geometric analysis of the 3D sheet metal model

The extraction of the main geometric drivers from a 3D model of a sheet metal part can be subdivided in two major parts: the reconstruction of the blank piece and the identification of deformation features.

The blank piece is the portion of a flatten sheet that is the starting point of the folding or stamping process. For cost estimation tasks, the blank geometry is obtained by using a simplified reverse engineering approach, starting from the 3D folded and deformed shape of the final component. The degree of deformation impressed to the original foil can vary considerably. As shown in the Figure 1, deformation can be limited to local portions such as bends and dimples and are hereafter referred as *local deformations*. On the other side, in many fields, such as automotive and household appliances, is quite common to have complex deformations extended to the whole parts,

referred in the following as *global deformations*. Components such as that one presented in Figure 1b are beyond the approach presented in this paper.

From a geometric point of view, a sheet metal 3D model is usually modelled as a constant thickness solid, whose surfaces may consist or not of developable faces, i.e. planes, cylinders, cones. A face is considered developable if it is linear at least along one direction. Non-developable faces are manufactured allowing a certain degree of deformation, which will produce changes in the sheet metal thickness because of stretching or accumulation of material. In common mechanical CAD systems, such thickness variation is not represented for the sake of simplicity.

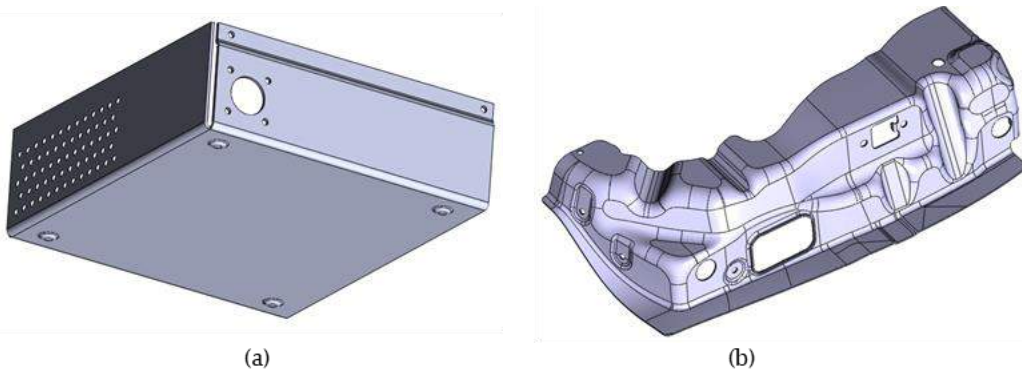

**Figure 1:** A stamped sheet metal part with local features such as bends, cutouts, dimples (a) and a more complex highly deformed automotive component (b).

The geometric analysis is based on the following main steps:

1. **Identification of the part thickness**, i.e. the recurrent distance between pairs of opposite faces. To this purpose, planar, cylindrical and conic pairs of faces with constant distance and opposite normal are considered.
2. **Subdivision of the model faces in three groups**, namely the *front skin*, the *back skin* and the *border faces*. Front and back skin (see Figure 2) are identified based on the smoothness properties of the connection between faces. Two faces are smoothly joined if the solid angle evaluated on the connection edge is around 180 degrees. Besides, front and back clusters have similar extension and maximise the number of opposite face pairs.

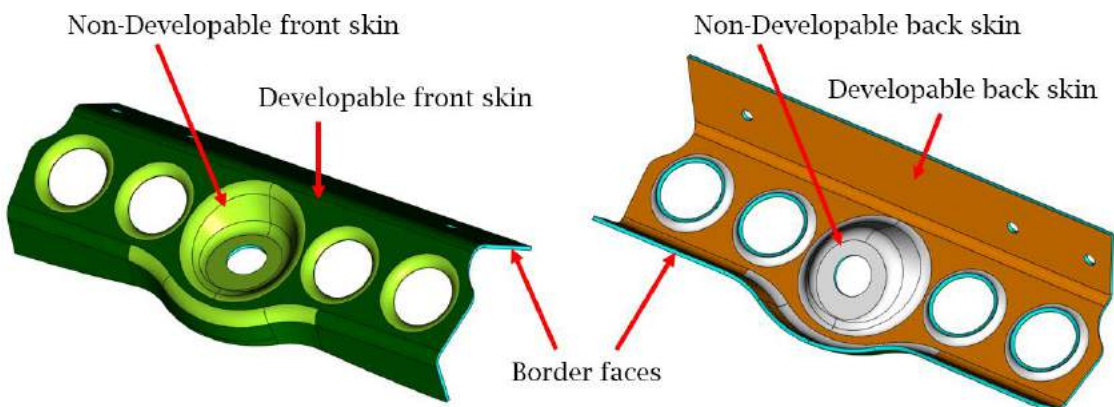

**Figure 2:** Initial classification of the faces in front skin (green), back skin (orange/white) and borders (cyan). Skin faces are separated in developable (dark green/orange) e non-developable faces (light green/white).

- For each of the two front and back skins, faces are distinguished among developable and non-developable faces. One skin is chosen as reference, namely the front one. A **flattening graph** is built from the adjacency information of the only developable faces of the skin as shown in Figure 3. The root of the graph is chosen as the most extended developable face of the skin.

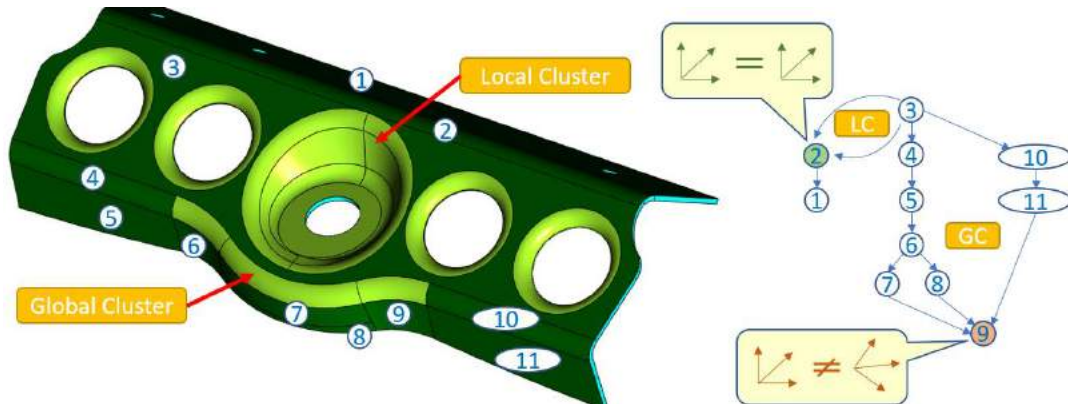

**Figure 3:** Flattening graph initialization from the developable faces of the front skin. Local (LC) and global (GC) deformation clusters are identified from the graph.

- Flattening of the developable faces** by analytical transformations based on the linearity of the geometry along one direction. The transformation to position each flatten face in the flattening plane is recorded.
- Non-developable faces of the selected skin are grouped in connected clusters. Each cluster is classified as **local** or **global**. Global cluster is given when:
  - faces surrounding the cluster identify a cycle in the flatten tree;
  - a node of the cycle, such as node 9 in Figure 3, has non-univocal flattening transformation;
  - other cases produce local clusters. Local cluster exceeding a relative dimensional threshold are considered global.
- Flattening of the non-developable faces.** This step requires the combination of few algorithms to project a tessellation of the face, including projection on a plane, projection in the parameters space or progressive mesh facets flattening as in [9]. A spring-based relaxation process follows to ensure the minimization of the deformation energy.
- Alignment of the non-developable flattened faces**, following the topology of the original model. Connection edges among faces are used to derive the best alignment thanks to an Iterative Closest Point algorithm (see Figure 4).
- Joining of the flatten faces to build the final shape of the blank.** A further relaxation is required to stretch the flatten faces and match their borders thanks to the introduction of springs with high elastic constant between corresponding points of the borders to be joined. Local clusters and internal trims are filled to guarantee a more realistic relaxation process.



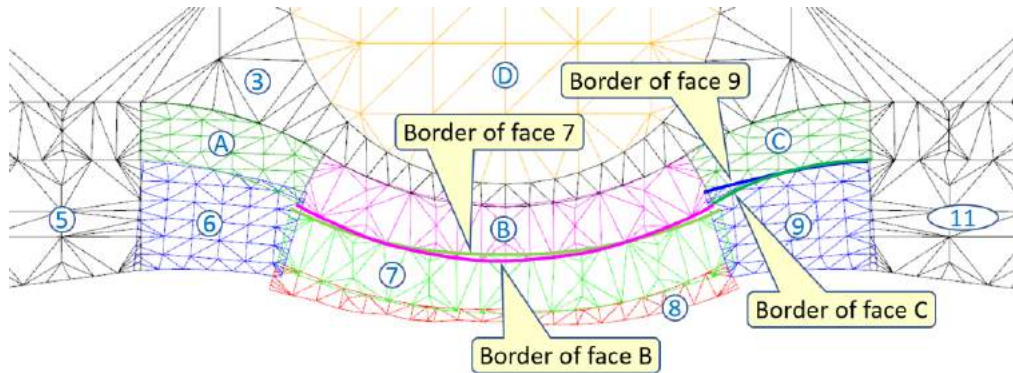

**Figure 4:** After the initial flattening of developable faces, remaining flatten mesh are positioned according to a best-fit of connection borders. Faces identified as local clusters, as face D, are substituted by a single mesh.

The described process allows the identification of an approximate blank shape and some deformation clusters. The main geometric parameters extracted by the blank shape are:

- *Sizes*, width and length of the blank bounding box (*BlankWidth* and *BlankLength*);
- *Thickness*, distance between the front skin and the back-skin faces, the same as the 3D model (*SheetmetalThickness*);
- *Perimeter*, length of the outer and inner contours. These parameters directly influence force required to cut the blank borders from the raw material (*BlankPerimeter* and *CuttingPerimeter*);
- *Stamping area*, area of the front skin. This parameter directly influences the stamping force (*StampingArea*);
- *Step distance*, distance between two adjacent parts in the stamping process (*StepDistance*).

The recognition of local deformation clusters is beneficial to trigger cost driver connected to the realization of specific geometric features such as louvres, dimples, bends, flared holes and darts. To this aim, the geometric parameters to be extracted are linked to the geometry of the identified cluster:

- *Sizes*, width and length of the bounding box of the face set;
- *Perimeter*, length of the outer contour;
- *Area*, area of either the set of faces from the front or back faces;
- *Type*, intended as the specific type such as dimple, dart, louvre, etc.

## 2.2 Cost estimation approach

The analytical cost estimation approach presented in this paper aims to calculate the following manufacturing cost items:

- *Raw material*: cost of the raw material used to realize the product. It considers scraps (e.g. internal cutouts, irregular external shape) and potential revenues from them. Coil, band, rectangular or shaped sheet metal are typical shapes of raw material;
- *Stamping process*: cost for transforming a blank in the final product. This is the cost related to the direct stamping phase of the press, which accounts the energy consumption, labour, consumable, overhead and depreciation;
- *Accessory processes*: cost for the collateral operations, such as tolerances inspection, coil or sheets pallet replacement;
- *Setup*: cost for preparing the press before starting the production (e.g. die load/unload, coil first load);

- *Tooling*: cost of the die and its maintenance. The first cost item is beyond the scope of this work (this is a capital expenditure), whereas the maintenance is accounted apart (this is an operational expenditure).

An analytical cost estimation approach is essentially a combination of data, knowledge and algorithms, consisting of:

- Product related information (e.g. shape, dimensions, tolerances, surface finish, etc.);
- Feature recognition algorithms for extracting production features from a 3D virtual model;
- Cost models and routings with the knowledge required for converting product features in process information and cost;
- Database of process related information (e.g. presses and related parameters, coils, sheet metals, materials and related parameters)

The cost estimation approach consists in a sequence of eight steps (Figure 5).

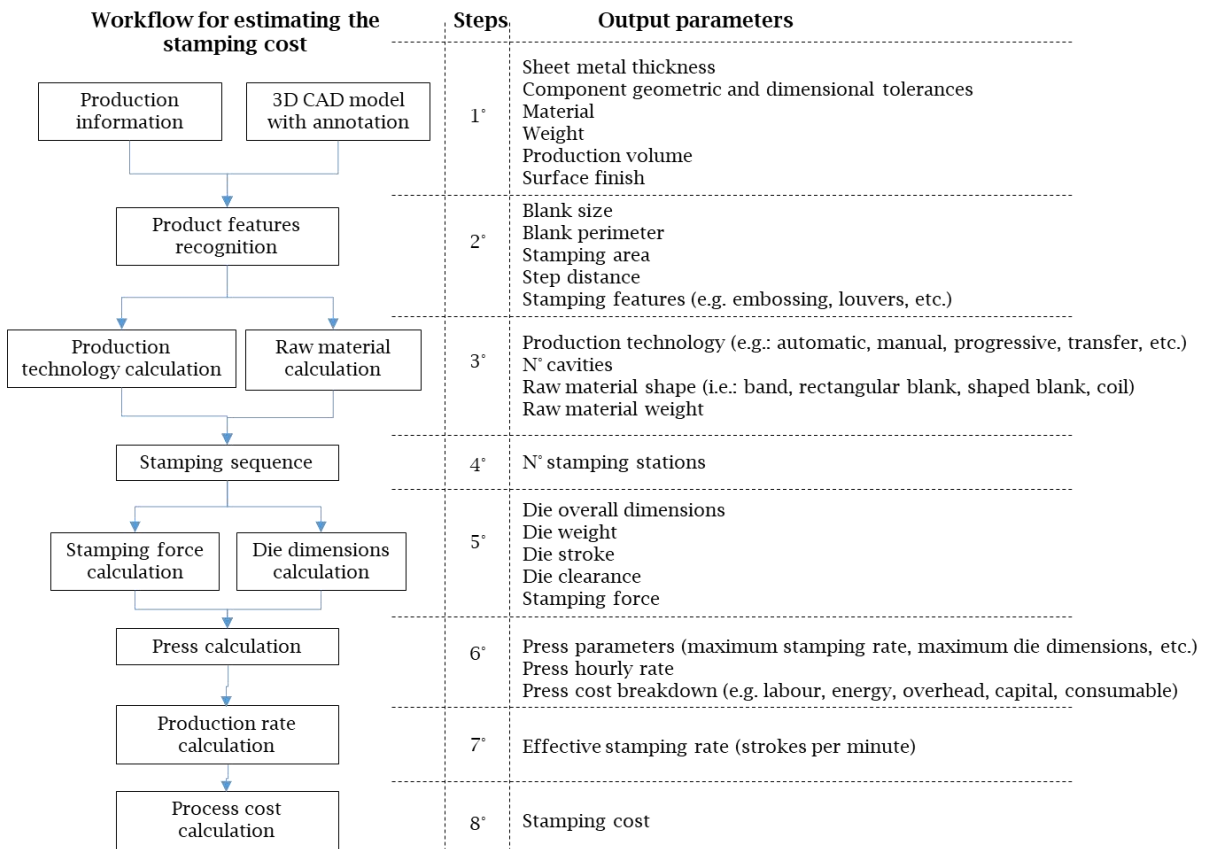

**Figure 5:** Workflow for estimating the stamping cost.

The starting point (**1° Step**) is the analysis of the 3D CAD model with Product Manufacturing Information and manufacturing scenario. The product-related parameters (Figure 6a) are: material, height, length, thickness and width of the stamped component and general dimensional (f, m, c and v) and geometric tolerances (H, K, L). Production-related information are production batch (components manufactured after the press set-up) and production volume (components manufactured during the die life).

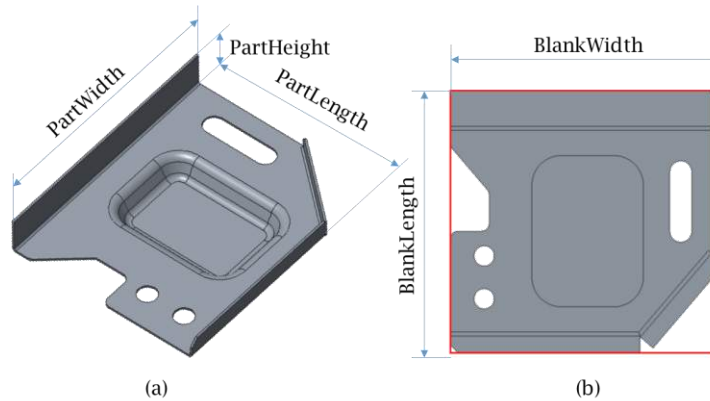

**Figure 6:** Part (a) and blank (b) dimensions.

The **2° step** aims to identify the sheet metal blank from the 3D virtual model of the component (Figure 6b). This step is necessary for defining the relevant features that, otherwise, are difficult to manually extract from a 3D CAD model.

The **3° step** has two objectives: (i) to establish the raw material with related parameters/cost, and (ii) to establish the production technology. The raw material changes considerably with the blank shape. According to the blank shape, piece dimensions and presence of undercuts, four different types of raw materials could be considered: (i) a *band* (rectangular blank manually moved by the operator within the press), (ii) a *coil* (continuous stamping process), (iii) a *rectangular sheet* (discrete stamping process), and (iv) a *shaped sheet* (blank with a perimeter shaped with other cutting processes, such as laser). Moreover, the stamping process differs a lot according to the production volume, blank shape, piece dimensions and other piece related parameters (e.g. presence of undercuts, surface finish). For instance, low production volumes (e.g. less than 2.000 products/year) force the adoption of a manual stamping process. For high production volumes, a manual approach is generally not economically sustainable; hence, an automatic stamping process should be preferred. Moreover, the way the blanks move within the die, determines two different stamping approaches: *progressive* (metal strip moves through the drawing process) or *transfer* (a transfer system moves the part from station to station).

The selection of the raw material and stamping process is a combined result of a selection tree (Figure 7). The knowledge at the first level determines whether the process is *automatic* (the press and its auxiliaries automatically move the blank) or *manual* (the operator manually moves the blank). The second level of knowledge allows calculating the type of raw material. The last level of knowledge allows defining the stamping process for those branches where multiple solutions are available.

The raw material cost (*MaterialCost*, €), Eqn. (2.2.1) is the difference between the blank raw material cost (*BlankMaterialCost*, €) and revenue from stamping scraps (*ScrapValue*, €). The latter depends by the volumes difference between the blank (*BlankVolume*,  $mm^3$ ) and component (*ComponentVolume*,  $mm^3$ ). The cost items are calculated multiplying the raw material and scraps weight respectively for the virgin material cost (*UnitaryCost*, €/kg) and scrape price (*UnitaryCost* \* *ScrapRecoveryPercent* / 100, €/kg).

$$\text{MaterialCost} = \text{BlankMaterialCost} - \text{ScrapValue} \quad (2.2.1)$$

$$\text{BlankMaterialCost} = \text{BlankVolume} * \text{Density} * \text{UnitaryCost} \quad (2.2.2)$$

$$\text{ScrapValue} = \text{ScrapVolume} * \text{Density} * \text{UnitaryCost} * \text{ScrapRecoveryPercent} / 100 \quad (2.2.3)$$

$$\text{ScrapVolume} = \text{BlankVolume} - \text{ComponentVolume} \quad (2.2.4)$$

$$\text{ComponentVolume} = \text{Stamping area} * \text{SheetmetalThickness} \quad (2.2.5)$$

$$\text{BlankVolume} = \text{BlankLength} * \text{BlankWidth} * \text{SheetmetalThickness} \quad (2.2.6)$$





$$\begin{aligned} \text{Phases} &= \text{Precutting} + \text{PerimeterCut} + \text{HolePunches} + \text{Coining} + \text{Bending} + \text{Embossing} + \text{Flanges} + \text{Shearing} + \text{VoidPasses} \\ &\quad (2.2.7) \\ \text{Precutting} &= \text{IF} (\text{StampingTechnology} = \text{"Transfer"} \text{ OR } \text{StampingTechnology} = \text{"Progressive"} ; 1 ; 0 ) \quad (2.2.8) \\ \text{PerimeterCut} &= \text{IF} (\text{StampingTechnology} = \text{"Transfer"} \text{ OR } \text{StampingTechnology} = \text{"Progressive"} ; 1 ; 0 ) \quad (2.2.9) \\ \text{HolePunches} &= \text{IF} (\text{HoleAndCutoutPresence} = 1 ; 1 ; 0 ) \quad (2.2.10) \\ \text{Coining} &= \text{IF} (\text{StrictestTolerance} \leq \text{ToleranceLimit} ; 1 ; 0 ) \quad (2.2.11) \\ \text{Bending} &= \text{ConsecutiveBends} \quad (2.2.12) \\ \text{Embossing} &= \text{IF} (\text{EmbossingPresence} = 1 ; 1 ; 0 ) \quad (2.2.13) \\ \text{Flanges} &= \text{IF} (\text{isFlaredHole} = 1 ; 1 ; 0 ) \quad (2.2.14) \\ \text{Shearing} &= \text{IF} (\text{StampingTechnology} = \text{"Progressive"} ; 1 ; 0 ) \quad (2.2.15) \end{aligned}$$

The equations consider the part shape such as the presence of hole, bending, coining, flanges, multiple deep drawing, flared holes, consecutive bends, embossing and geometric tolerances (orientation, perpendicularity, parallelism and angularity). Such features (i.e. *local deformation clusters*) are calculated through specific feature recognition algorithms.

The **5° step** has two objectives: (i) to calculate the stamping force (*RequiredTonnage, ton*), Eqn. (2.2.16), and (ii) to assess the die dimensions (*DieLength, mm* and *DieWidth, mm*), Eqn. (2.2.23). The stamping force calculation process is based on simplified and parametric formulas rather than a simulation process because the impossibility to specify detailed boundary conditions of the stamping process. The stamping force considers the contributions of each stamping operation, which are: precutting, perimeter cutting, punching, embossing and banding.

$$\begin{aligned} \text{RequiredTonnage} &= \text{PrecuttingTonnage} + \text{PerimeterCutTonnage} + \text{PunchingTonnage} + \text{EmbossTonnage} + \text{BendingTonnage} \\ &\quad (2.2.16) \\ \text{PrecuttingTonnage} &= \text{BlankPerimeter} * \text{SheetmetalThickness} * \text{UltimateShearStrength} \quad (2.2.17) \\ \text{PrecuttingNumber} &= \text{IF} (\text{StampingTechnology} = \text{"Transfer"} \text{ OR } \text{StampingTechnology} = \text{"Progressive"} ; 1 ; 0 ) \quad (2.2.18) \\ \text{PerimeterCutTonnage} &= \text{BlankPerimeter} * \text{SheetmetalThickness} * \text{UltimateShearStrength} \quad (2.2.19) \\ \text{PunchingTonnage} &= \text{PunchingPerimeter} * \text{SheetmetalThickness} * \text{UltimateShearStrength} \quad (2.2.20) \\ \text{EmbossTonnage} &= \text{EmbossingPerimeter} * \text{SheetmetalThickness} * \text{UltimateShearStrength} \quad (2.2.21) \\ \text{BendingTonnage} &= \text{TotalBendingLength} * \text{SheetmetalThickness} * \text{UltimateShearStrength} \quad (2.2.22) \end{aligned}$$

The die dimensions depend by blank width, number of stamping stations (*StationsNumber*) and distance between neighbouring silhouettes (*StepDistance, mm*).

$$\begin{aligned} \text{DieLength} &= \text{StationsNumber} * \text{BlankLength} + (\text{StationsNumber} - 1) * \text{StepDistance} \quad (2.2.23) \\ \text{DieWidth} &= \text{BlankWidth} + 2 * \text{StepDistance} \end{aligned}$$

The **6° step** aims to calculate the press used for stamping the blank. The selection is performed considering the required stamping force and die with related characteristics (i.e.: maximum die dimensions, maximum stroke, maximum clearance for mounting the die and maximum die weight).

The stamping rate (**7° step**) is then conservatively calculated considering the maximum stamping rate of the press, the maximum stamping rate that generates a deformation speed less than the threshold admitted by the material and the maximum stamping rate related to the combination of raw material and stamping method (see Figure 7). The stamping rate previously mentioned are adjusted by additional parameters, which are the weight of the die (the bigger the weight the lower the stamping rate), its level of wear (the higher the wear the lower the stamping rate) and any difficulties in its lubrication (the higher the difficulties the lower the stamping rate).

The last step (**8° step**) aims to calculate the cost of the stamped part (*Cost, €*), Eqn. (2.2.24). This is the sum of machine cost (*MachineCost, €*), labour cost (*OperatorCost, €*), accessory costs (*AccessoryItemCost, €*) for die maintenance and coils/sheet loading and setup cost (*SetupCost, €*). The latter refers is a lump sum cost per batch. The machine and operator cost are related to the stamping cycle time (*Time, min*), hence they depend by the stamping rate (*StampingRate, min<sup>-1</sup>*), number of silhouettes each die (*SilhouettesQuantity*), number of workers committed for each press (*OperatorCommitment, %*) and unitary cost of the press (*MachineUnitaryCost, €/min*) and labour (*OperatorUnitaryCost, €/min*). The coil and sheet loading cost, which determines a production interruption, depends by the quantity of coils (*CoilsQuantity*) or sheet pallets (*SheetPallets*) to be

loaded during the manufacturing of a batch. The unitary time depends by the coil or sheet pallet weights. The maintenance cost is computed considering the life of the die (*DieLife*, number of parts before a maintenance) and batch quantity (*BatchQuantity*). The setup cost accounts the die loading/unloading, transfer adjustment (if any) and machine adjustment. The unitary times are function of press size and die weight.

$$\begin{aligned} \text{Cost} &= ( \text{MachineCost} + \text{OperatorCost} ) / \text{SilhouettesQuantity} + \text{AccessoryItemCost} + \text{SetupCost} / \text{BatchQuantity} && (2.2.24) \\ \text{MachineCost} &= \text{Time} * \text{MachineUnitaryCost} && (2.2.25) \\ \text{OperatorCost} &= \text{Time} * \text{OperatorUnitaryCost} / 60 * \text{OperatorCommitment} / 100 && (2.2.26) \\ \text{Time} &= 1 / \text{StampingRate} && (2.2.27) \\ \text{OperatorCost} &= \text{Time} * \text{OperatorUnitaryCost} / 60 * \text{OperatorCommitment} / 100 && (2.2.28) \\ \text{AccessoryItemCost} &= ( \text{LoadingTime} + \text{MaintenanceTime} ) * \text{MachineUnitaryCost} && (2.2.29) \\ \text{LoadingTime} &= \text{UnitaryLoadTime} * \text{StockNumber} / \text{BatchQuantity} && (2.2.30) \\ \text{UnitaryLoadTime} &= \text{IF}(\text{LoadingType}="Coil"; \text{UnitaryCoilLoadTime}; \text{IF} (\text{LoadingType}="Sheet"; \text{UnitarySheetLoadTime}; 0)) && (2.2.31) \\ \text{StockNumber} &= \text{IF} ( \text{LoadingType} = "Coil" ; \text{CoilNumber} ; \text{IF} ( \text{LoadingType} = "Sheet" ; \text{SheetPallets} ; 0 ) ) && (2.2.32) \\ \text{CoilsQuantity} &= \text{BatchQuantity} \setminus \text{ComponentsPerCoil} && (2.2.33) \\ \text{SheetPallets} &= \text{BatchQuantity} \setminus \text{SilhouettesQuantity} && (2.2.34) \\ \text{MaintenanceTime} &= \text{MaintenanceUnitaryTime} * \text{StationsNumber} * \text{BatchQuantity} / \text{DieLife} && (2.2.35) \end{aligned}$$







The cost estimation approach leverages a huge amount of data available from a specific database, which contains the following group of data:

- *Material*: it contains data such as virgin material and scrap unitary cost/price, material ultimate shear strength, density and maximum strain rate.
- *Raw material*: it contains the lists of coils, bands shaped blanks and rectangular sheet metals that can be used for the stamping process. For each type of raw material, the database contains the related information (e.g.: for a coil, outer diameter, inner diameter, weight and thickness).
- *Machine and labour*: it contains the list of presses, with related information (i.e.: stamping tonnage, maximum allowed die dimensions, stroke, clearance, unitary cost of presses and labour, unitary time for accessory operations such as coil replacement) that can be used for the stamping process.
- *Tooling*: it contains a list of dies, classified in families according to size (number of stations), combination of stamping technology and raw material (e.g.: transfer, progressive, manual, etc.). For each family, this section of database contains tooling related parameters, used for accounting die maintenance and die load/unload.
- *Stamping technology*: it contains the knowledge for selecting the stamping technology according to the part features (e.g. selection rules shown in Figure 7).

### 3 CASE STUDIES AND RESULTS DISCUSSION

The proposed approach has been adopted for the estimation of several sheet metal parts. The case studies allow to test the effectiveness and the reliability of the developed algorithms considering different features in terms of part complexity and machines. The testing phase has been performed in cooperation with different manufacturers of sheet metal stamped products. Figure 8 shows the cost breakdown of three sheet metal components with different features and different complexity degrees.

As preliminary activity for the application of the proposed approach, a repository for the classification of available machines (presses) and equipment (dies, etc.) has been developed gathering data from the three manufacturers involved in the testing activity. The aim of this preliminary activity was to have a better matching between the estimated valued through the proposed approach and the real cost retrieved by the manufacturers themselves. Indeed, the use of different machines for a specific component can affect the cost rate in terms of time, number of steps, mechanized movements and reorientations which are typical aspects connected with the machine/equipment and not related to the product geometry.

	Component #1		Component #2		Component #3	
	Estimated	Manufactured	Estimated	Manufactured	Estimated	Manufactured
						
Material cost [€]	0.014	0.013	0.403	0.399	2.013	2.001
Revenue from scrap [€]	-0.002	-0.002	-0.041	-0.039	-0.187	-0.193
Stamping (drawing and cutting) cost [€]	0.044	0.042	0.051	0.055	0.593	0.679
Setup cost [€]	0.003	0.002	0.085	0.091	0.050	0.072
Loading cost [€]	0.003	0.003	0.010	0.011	0.029	0.038
Maintenance cost [€]	0.018	0.014	0.034	0.036	0.032	0.044
<b>Total cost</b>	<b>0.080</b>	<b>0.072</b>	<b>0.542</b>	<b>0.553</b>	<b>2.530</b>	<b>2.641</b>

**Figure 8:** Costs breakdown of three different sheet metal components (estimated vs. manufactured).

Based on the developed algorithms for 3D model analysis (i.e. feature recognition) and the adopted cost models, the estimated results are in line with the total cost provided by the parts manufacturers (maximum deviation of 10%). The higher gap is observed for *Component #1*, which can be considered the simplest part. *Component #1* requires only cutting operations to obtain the final geometry. In this case, the main difference is related to *Maintenance cost* (0.018 [€/piece] vs. 0.014 [€/piece]) because the proposed analytical model over-estimate the cost of maintenance operations. Indeed, the part complexity does not require a recurring maintenance of the die as calculated by the proposed algorithm and a deviation of approx. 28% is noticed. Concerning *Raw material* and *Stamping process* costs the outcome of the proposed algorithms are in line with the real costs provided by the part manufacturer (approx. gap 5%). The proposed flattening algorithm for developable faces were able to catch properly the simple geometry of the component, including the blanket shape, the stamping force and consequently the stamping rate.

Looking at *Component #2*, a maximum cost deviation of approx. 2% is observed on the total cost. Again, the flattening algorithm for developable faces are properly addressing the manufacturing process and the production steps providing a robust result for cost estimation. In this case, the gap is limited also for each single cost item. In particular, the estimated values for *Raw material* and *Stamping process* costs show a slight difference compared with the values provided by the manufacturer (respectively 0.403 [€/piece] vs. 0.399 [€/piece] for the *Raw material* and 0.051 [€/piece] vs. 0.055 [€/piece] for the *Stamping process*). A bigger gap is observed for the *Setup cost* with a gap of approx. 7%. In this case, the error noticed for the proposed algorithm can be considered acceptable.

Looking at *Component #3*, a maximum cost deviation of approx. 4% is observed on the total cost (2.530 [€/piece] vs. 2.641 [€/piece]). Again, as for *Component #2* the gap is limited, and the results of the proposed algorithms for the cost items closely approximate the cost breakdown provided by the manufacturer. An interesting aspect for this case study is the cost values of *Setup Cost* and *Loading Cost*. Indeed, a noticeable gap is observed between the estimated costs and the real ones (respectively 30% for the *Setup Cost* and 24% for the *Loading Cost*). However, they have a limited impact on the final result due to importance of these items compared with the other ones (e.g.; the material). In this specific case, the values of *Setup Cost* and *Loading Cost* are two orders of magnitude smaller than the *Material cost*. Anyway, the developed algorithms for these items underestimate the cost value because *Component #3* is a complex part that required a higher time for the machine set-up. Considering the *Material costs* and *Revenues from scraps* items, the differences between the estimated vs. manufactured costs are coming from the step distance (distance between two adjacent parts in the stamping process) in the progressive stamping process. In this case, the presence of specific geometric features such as louvres, which determine local

deformation are not properly assessed by the adoption of the proposed algorithm for the local deformation clusters (non-developable faces alignment and joining).

As a general remark, *Raw material* and *Stamping process* costs are in line with the costs breakdown provided by the parts manufacturers and it represents a robust result of the geometrical analysis of the virtual model including the identification of key parameters for sheet metal drawing. However, mathematical models for cost estimation need to be refined to catch differences in products with specific features (e.g. maintenance, set-up).

#### 4 CONCLUSIONS AND FUTURE WORK

The paper presented an analytical cost estimation approach for sheet metal stamped components. This approach represents a solution toward the adoption of Design to Cost methods during early product design. The method consists in a workflow that, starting from a 3D CAD model with annotations (material, roughness and tolerances) and production information (batch and production volume) leads to the manufacturing cost through an analytic cost breakdown (raw material, stamping, setup and tooling). The calculation process mainly consists in a first step where geometric algorithms calculate the sheet metal blank (dimensions, shape, thickness) and specific product features (e.g. flanges, louvers, embossing, etc.). The following steps calculate the raw material, the stamping process and the process-related parameters, which are the manufacturing cost drivers (e.g. press, stamping rate/sequence/force and die dimensions/weight). The manufacturing cost is the sum of the previous calculated items.

The algorithms and equations have been implemented within a software tool (*LeanCOST* by *Hyperlean srl*). The approach has been tested for several components, even if the paper presents only three of the analyzed parts, selected for their different level of complexity. The aim of the test was the evaluation of the accuracy in estimating the manufacturing cost (once set the elementary cost information, namely unitary raw material cost and hourly rate of the press and labor). The average absolute deviation was less than 10% and such a result looks promising for adopting this method for evaluating alternative design solutions (Design to Cost).

So far, the approach encompasses only sheared/bended parts without deep drawings. Future work will aim to integrate deep drawing cost estimation rules with those ones presented in this paper. Furthermore, algorithms for the 3D CAD model analysis should be extended to cover such a process.

#### ACKNOWLEDGMENT

The authors want to thank *Hyperlean srl* for the support in testing the geometric algorithms and the cost model by using the software *LeanCOST*.

Marco Mandolini, <http://orcid.org/0000-0003-0962-5982>

Claudio Favi, <http://orcid.org/0000-0002-7176-0731>

Michele Germani, <http://orcid.org/0000-0003-1988-8620>

Marco Marconi, <http://orcid.org/0000-0002-5677-1459>

Roberto Raffaelli, <http://orcid.org/0000-0003-0301-454X>

#### REFERENCES

- [1] Cai, Z.-Y.; Li, M.-Z.; Zhang, H.-M.: A simplified algorithm for planar development of 3D surface and its application in the blank design of sheet metal forming, *Finite Elements in Analysis and Design*, 43(4), 2007, 301-310. <https://doi.org/10.1016/j.finel.2006.10.005>
- [2] Duran, O., Maciel, J., Rodriguez, N.: Comparisons between two types of neural networks for manufacturing cost estimation of piping elements, *Expert Systems with Applications*, 39(9), 2012, 7788-7795. <https://doi.org/10.1016/j.eswa.2012.01.095>



- [3] Gao, J., Zheng, D., Gindy, N.: Mathematical representation of feature conversion for CAD/CAM system integration, *Robotics and Computer-Integrated Manufacturing*, 20(5), 2004, 457-467. <https://doi.org/10.1016/j.rcim.2004.05.001>
- [4] Hattalli, V.L., Srivatsa, S.R.: Sheet Metal Forming Processes – Recent Technological Advances, *Materials Today: Proceedings*, 5(1), 2018, 2564-2574. <https://doi.org/10.1016/j.matpr.2017.11.040>
- [5] Jong, W.-R.; Lai, P.-J.; Chen, Y.-W.; Ting, Y.-H.: Automatic process planning of mold components with integration of feature recognition and group technology, *The International Journal of Advanced Manufacturing Technology*, 78(5-6), 2015, 807-824. <https://doi.org/10.1007/s00170-014-6627-4>
- [6] Karadgi, S.; Muller, U.; Metz, D.; Schafer, W.; Grauer, M.: Cost estimation of automotive sheet metal components using knowledge-based engineering and case-based reasoning, *Proceedings of the 2009 IEEE International Conference on Industrial Engineering and Engineering Management*, 2009. <https://doi.org/10.1109/IEEM.2009.5373084>
- [7] Li, J.; Zhang, D.; Lu, G.; Peng, Y.; Wen, X.; Sakaguti, Y.: Flattening triangulated surfaces using a mass-spring model, *The International Journal of Advanced Manufacturing Technology*, 25(1-2), 2005, 108-117. <https://doi.org/10.1007/s00170-003-1818-4>
- [8] Liang, W.; Bin, H.: Optimal flattening of freeform surfaces based on energy model, *The International Journal of Advanced Manufacturing Technology*, 24(11-12), 2004, 853-859. <https://doi.org/10.1007/s00170-003-1801-0>
- [9] Liu, Q., Xi, J., Wu, Z.: An energy-based surface flattening method for flat pattern development of sheet metal components, *The International Journal of Advanced Manufacturing Technology*, 68(5-8), 2013, 1155-1166. <https://doi.org/10.1007/s00170-013-4908-y>
- [10] McCartney, J.; Hinds, B.K.; Seow, B.L.: The flattening of triangulated surfaces incorporating darts and gussets, *Computer-Aided Design*, 31(4), 1999, 249-260. [https://doi.org/10.1016/S0010-4485\(99\)00025-1](https://doi.org/10.1016/S0010-4485(99)00025-1)
- [11] Molcho, G., Cristal, A., Shpitalni, M.: Part cost estimation at early design phase, *CIRP Annals – Manufacturing Technology*, 63(1), 2014, 153-156. <https://doi.org/10.1016/j.cirp.2014.03.107>
- [12] Nagahanumalah, Ravi, B., Mukherjee, N.P.: An integrated framework for die and mold cost estimation using design features and tooling parameters, *The International Journal of Advanced Manufacturing Technology*, 26(9-10), 2005, 1138-1149. <https://doi.org/10.1007/s00170-004-2084-9>
- [13] Naranje, V., Kumar, S.: A Knowledge Based System for Selection of Components of Deep Drawing Die, *Expert Systems with Applications*, 41(4), 2014, 1419-1431. <https://doi.org/10.1016/j.eswa.2013.08.041>
- [14] Niazi, A.; Dai, J.S.; Balabani, S.; Seneviratne, L.: Product Cost Estimation: Technique Classification and Methodology Review, *Journal of Manufacturing Science and Engineering*, 128(2), 2005, 563-575. <https://doi.org/10.1115/1.2137750>
- [15] Sajadfar, N., Ma, Y.: A hybrid cost estimation framework based on feature-oriented data mining approach, *Advanced Engineering Informatics*, 29(3), 2015, 633-647. <https://doi.org/10.1016/j.aei.2015.06.001>
- [16] Shen, H., Wang, H., Hu, J., Yao, Z.: An elastic approach for developing non-developable sheets, *International Journal of Mechanical Sciences*, 106, 2016, 138-146. <https://doi.org/10.1016/j.ijmecsci.2015.12.013>
- [17] Shehab, E.M., Abdalla, H.S.: Manufacturing cost modelling for concurrent product development, *Robotics and Computer-Integrated Manufacturing*, 17(4), 2001, 341-353. [https://doi.org/10.1016/S0736-5845\(01\)00009-6](https://doi.org/10.1016/S0736-5845(01)00009-6)
- [18] Sunil, V.B.; Pande, S.S.: Automatic recognition of features from freeform surface CAD models, *Computer-Aided Design*, 40(4), 2008, 502-517. <https://doi.org/10.1016/j.cad.2008.01.006>
- [19] Tang, D.-B., Zheng, L., Li, Z.-Z.: An Intelligent Feature-Based Design for Stamping System, *The International Journal of Advanced Manufacturing Technology*, 18(3), 2001, 193-200. <https://doi.org/10.1007/s001700170074>

- [20] Tor, S.B.; Britton, G.A.; Zhang, W.Y.: A knowledge-based blackboard framework for stamping process planning in progressive die design, *The International Journal of Advanced Manufacturing Technology*, 26(7-8), 2005, 774-783. <https://doi.org/10.1007/s00170-003-2037-8>
- [21] Verlinden, B.; Duflou, J.R.; Collin, P.; Cattrysse, D.: Cost estimation for sheet metal parts using multiple regression and artificial neural networks: A case study, *International Journal of Production Economics*, 111(2), 2008, 484-492. <https://doi.org/10.1016/j.ijpe.2007.02.004>
- [22] Wang, C.C.L., Smith, S.S.-F., Yuen, M.M.F.: Surface flattening based on energy model, *Computer-Aided Design*, 34(11), 2002, 823-833. [https://doi.org/10.1016/S0010-4485\(01\)00150-6](https://doi.org/10.1016/S0010-4485(01)00150-6)
- [23] Zhao, X.; Verhagen, W.J.C.; Curran, R.: Estimation of aircraft component production cost using knowledge based engineering techniques, *Advanced Engineering Informatics*, 29(3), 2015, 616-632. <https://doi.org/10.1016/j.aei.2015.05.004>
- [24] Zhong, Y.; Xu, B.: A physically based method for triangulated surface flattening, *Computer-Aided Design*, 38(10), 2006, 1062-1073. <https://doi.org/10.1016/j.cad.2006.05.002>