

# ALMA MATER STUDIORUM - UNIVERSITÀ DI BOLOGNA

---

## SCUOLA DI INGEGNERIA E ARCHITETTURA

Dipartimento di Ingegneria Industriale

Corso di Laurea Magistrale in Ingegneria Energetica

**Tesi di Laurea in Applicazioni Industriali dei Plasmi M**

## **PRODUZIONE E CARATTERIZZAZIONE DI ACQUA ATTIVATA MEDIANTE PLASMI FREDDI ATMOSFERICI PER APPLICAZIONI IN AGRICOLTURA**

### **CANDIDATO**

Andrea Callegari

### **RELATORE**

Dott. Gherardi Matteo

### **CORRELATORI**

Prof. Colombo Vittorio

Dott. Laurita Romolo

Dott.ssa Puač Nevena

Dott. Škoro Nikola

Anno Accademico 2018-2019

II appello



# Summary

<b>1. Introduction.....</b>	<b>1</b>
<b>2. Materials and Methods.....</b>	<b>9</b>
2.1 COST jet.....	9
2.2 DBD jet.....	13
2.3 PAW production and imbibition of seeds.....	15
2.4 Characterization of PAW.....	21
<b>3. Results and Discussion .....</b>	<b>24</b>
3.1 Physicochemical properties of PAW.....	24
3.2 Seeds germination.....	29
<b>4. Conclusions and Outlooks .....</b>	<b>34</b>
<b>Bibliography .....</b>	<b>36</b>



# Chapter 1

## Introduction

Within a few decades, the world population is expected to reach the number of 10 billion, posing a great challenge to agriculture, that will be required to meet, in a sustainable and economically viable way, an enormously increasing demand for accessible and safe food [1]. Moreover, according to the United Nations Food and Agriculture Organization (FAO), global food shortages will become three times more likely, as a consequence of climate change and related severe drought conditions, and due to the fast development of industrialization and urbanization [2]. Since nowadays the cultivable land has almost reached its maximum extent, the most viable solution to limit food shortages consists in increasing crop yields [3]. There is a huge (up to 75%) gap, especially in developing countries, between real yields and the potential yields that could be obtained with optimal growth conditions [4]; a general improvement in agriculture and food processing efficiency appears to be essential, but the conventional methods employed so far (insecticides, fungicides or other chemicals), even if effective, have been proved to be potentially harmful to the environment and the human health. Hence, new alternative approaches are needed [5].

LTPs (Low Temperature Plasmas) have recently drawn attention for several agricultural applications as a promising, innovative and eco-friendly solution, whose rapid development is fuelled by the consolidated knowledge and experience developed in the field of “Plasma Medicine”.

If for a long time the use of plasma technology for food processing was restricted to applications in the field of packaging, in the last decade it has been established that cold plasmas can be beneficial in most of the steps involved in the lifecycle of fresh produce, from pre-planting to post-harvest. Ito et al. classified plasma-agricultural applications into three categories [6]: in the first one there are applications related to the inactivation of microorganisms and bacteria, like decontamination of seeds, reduction of pathogens in soil and sterilization of packaging materials or other food processing

equipment. Thanks to their non-equilibrium nature, cold plasmas can exert antibacterial effects without thermally damaging products or other heat sensitive materials.

A second group of applications are concerned with the removal or conversion of volatile organic compounds during storage and transport of fresh produce. For instance, systems to decompose ethylene gas have been studied: this gaseous plant hormone, emitted by some fresh produce, accelerates ageing for themselves and for other products in the same container. Other techniques are used to inactivate endogenous enzymes which are responsible for browning reactions. Applications from both the first and the second categories aim to increase the shelf-life of fresh produce [7].

The third category, consisting in the promotion of seed germination and plant growth, has also attracted much attention. As in most of LTP applications, the great majority of experiments on germination and growth of seeds was initially carried out with low-pressure plasmas, usually in the range of few hundreds of mTorr, because seeds can survive under these conditions [8]. Experiments with low pressure plasmas generally led to positive results, with the modification of the seed surface wettability and consequently improved water uptake. More recently, the interest has moved towards the development of plasma sources operating at atmospheric pressure. Even though the volume of plasma is typically smaller and it is more difficult to achieve stable non-equilibrium conditions, working at atmospheric pressure offers several advantages: as they do not require vacuum systems, simpler and cheaper experimental setups are allowed. Moreover, they are suitable for continuous treatment, while low pressure only enables batch processing, and do not limit the scaling up process. Lastly, the possibility to work with liquids at atmospheric pressure cannot be disregarded [9].

For both atmospheric pressure and low-pressure plasmas, the most significant effects on seeds can be attributed to the blend of atomic, radical, ionic and molecular species, collectively referred as RONS (Reactive Oxygen and Nitrogen Species), which is generated when plasma is ignited in air, or oxygen and/or nitrogen are included in the feeding gas.

Considering only atmospheric pressure plasmas, there are two different modes of application: in the so-called direct method, seeds are placed in direct contact with the

discharge or near the plasma region. Highly reactive species, including hydroxyl radical ( $\text{OH}\cdot$ ), nitric oxide ( $\text{NO}$ ), nitric dioxide ( $\text{NO}_2$ ), superoxide anion ( $\text{O}_2^-$ ), singlet oxygen ( $^1\text{O}_2$ ) and ozone ( $\text{O}_3$ ) [10], reach the seeds and chemically etch their coat structure with the aim of increasing their wettability and permeability, thereby improving water uptake. At the same time seed surface is decontaminated from pathogens and bacteria. But similar results can be obtained through the indirect method, where a liquid medium is pre-treated with a cold plasma device and then applied to seeds. When water is used as medium, the resulting solution is called PAW (Plasma-Activated Water). Here, effects are mainly attributed to the major long-lived species which remain in solution after plasma treatment, i.e. hydrogen peroxide ( $\text{H}_2\text{O}_2$ ), nitrites ( $\text{NO}_2^-$ ) and nitrates ( $\text{NO}_3^-$ ) [11].

The study of RONS kinetics is not among the main purposes of this thesis, but a set of the chemical reactions taking place during PAW generation can be found elsewhere [1]. In brief, hydrogen peroxide is mainly produced in the gas phase through the recombination of  $\text{OH}\cdot$  and dissolves afterwards into the water [12]. At the gas-liquid interface oxides of nitrogen ( $\text{N}_x\text{O}_y$ ) react with water molecules or hydroxyl radicals to generate nitrous ( $\text{HNO}_2$ ) and nitric acid ( $\text{HNO}_3$ ) that subsequently ionize leading to the formation of nitrites and nitrates respectively [13].

RONS are supposed to play the role of signalling molecules in plant biology: they are naturally produced inside the cell but providing seeds with an additional amount of reactive species, generated through the exposure of a liquid medium to cold plasma, could induce beneficial effects. Thus, biologists introduced the concept of "oxidative window", within which germination can be successfully achieved. The interaction of RONS with plant hormones and enzymes regulates the breakdown of seed dormancy and triggers the initiation of germination [14]. Furthermore, hydrogen peroxide is also involved in antimicrobial effect, whereas nitrites and nitrates are a source of nitrogen as well, one of the essential nutrients for plant metabolism.

Several papers deal with the treatment of seeds and plenty of devices and configurations have been investigated. Ling et al., for instance, studied the effects of low-pressure plasma on germination and seedling growth of soybean seeds [15]. Seeds were exposed for 15 s to cold plasma generated in a capacitively coupled device,

operating in helium at 150 Pa with a frequency of 13.56 MHz and subsequently 10 ml of distilled water was added to trigger germination. During the experiments, in order to maintain sufficient moisture for seeds, 5 ml of distilled water was added for every following day. Among the four power levels tested (60, 80, 100 and 120 W), treatment with 80 W induced the highest stimulatory effects: final germination percentage (the ratio between germinated seeds and the total number of treated seeds multiplied by 100) reached 90%, compared to 82% of control and water uptake (the amount of water absorbed by seeds) improved by 14%, while apparent contact angle (the angle that a water droplet creates with a solid interface; it quantifies the wettability of a surface) decreased by 26%. Characteristic parameters of the seedling growth improved as well, as shoot and root length increased by 14% and 21% respectively, as compared to control sample.

A comparison between a low-pressure direct treatment and a treatment mediated by PAW was carried out by Puač et al. [16]. In particular, enzyme activity involved in antioxidant defence was investigated during the early phase of germination of *Paulownia tomentosa* seeds. A cylindrically shaped capacitively coupled reactor was employed for low-pressure treatments: the axial electrode was powered by an RF signal at 13.56 MHz at 100 W, while seeds were positioned in a platform on the grounded electrode, 13 cm below the high-voltage one. Treatments were performed in oxygen at 200 and 600 mTorr, exposure time of 1, 5, 10 and 20 minutes were considered and eventually 3 ml of distilled water was added to seeds, after plasma treatments. PAW generation was performed treating 12 ml of distilled water for 5, 10, 20 minutes by means of a plasma jet, with a frequency of 50 kHz and a flow rate of 4 slpm of helium gas. Applied voltage was kept constant at 6 kV peak-to-peak for two distances taken into account (0.5 and 1 cm) between the lower extremity of the plasma source and the liquid surface. The schematics of the two setups are represented in Fig. 1.

Both plasma treatments induced a decrease in enzyme activity in first two days compared to control samples, but the increase noticed afterwards could suggest that treated seeds entered earlier the following phase of germination.





The combined effects of direct and indirect treatments on radish, tomato and sweet pepper seeds were investigated by Khacef et al. [3]. For both reactors, a constant flow rate of 1 slpm of air was considered and an identical pulsed voltage (40 kV, 1 kHz) was applied. The device for PAW generation consisted in a cylindrical double DBD reactor with a couple of tungsten wire electrodes inserted in glass tubes, whose extremities were immersed into 250 ml of deionized water in order to improve dissolution of plasma-induced reactive species. For direct treatment of seeds, a plate-to-plate double DBD was employed, with two aluminium tape electrodes positioned on the outer surface of two glass plates. Schematics of both reactors are represented in Fig. 3.

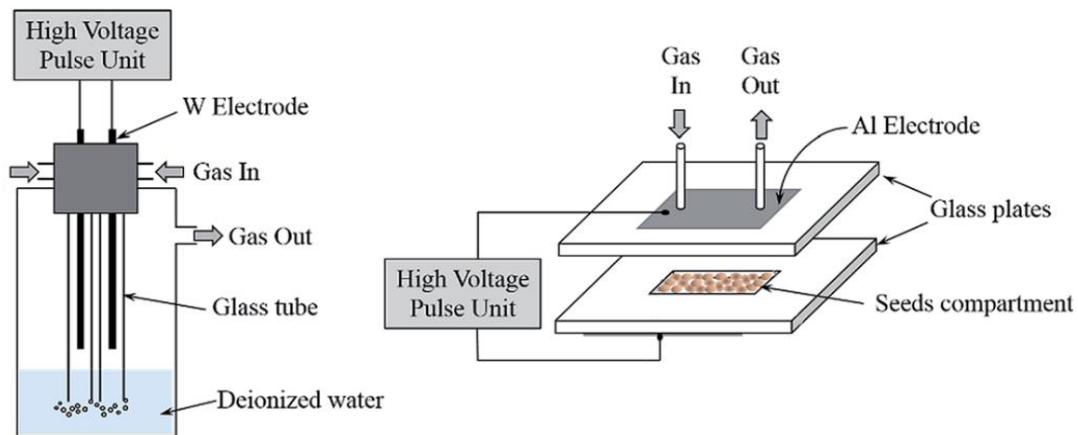

**Figure 3.** Schematics of plasma reactors used for PAW generation (left) and direct treatment of seeds (right) [3]

When tomato and sweet pepper seeds were exposed to cold plasma for 10 minutes and afterwards watered for 9 days with PAW-15 and with tap water for following 51 days, stem length increased by about 60% as compared to control samples. Treatments on radish seeds showed either short and long-term effects: one day after imbibition, germination percentage was about 40% with tap water, whereas 60% and 100% was respectively achieved by PAW-15 and PAW-30. Furthermore, after 9 days, seeds treated for 10 minutes and watered with PAW-15 generated plants, whose stems were 50% longer than control samples.

Černak et al. presented an interesting prototype for in-line treatment of seeds, named Diffuse Coplanar Surface Barrier Discharge [19]; the system is operated at

atmospheric pressure in ambient air and was used to treat cucumber and pepper seeds. DCSBD consisted of parallel strip-line metallic electrodes embedded in alumina ceramics and supplied with AC high voltage at 15 kHz and an input power of 400 W. The prototype presented four discharge units, a system of moving brushes to ensure movement of seeds and a final collecting vessel for treated seeds (Fig. 4): this semi-industrial approach guaranteed a continuous plasma treatment of seeds.

Final germination percentage for cucumber increased from 92% for untreated sample to 97% after 20 s of cold plasma exposure, while only 4 s were sufficient to significantly promote pepper seeds germination from 72% to 89%. Such brief timeframes also proved to be able to reduce or eliminate several microorganisms and pathogens without evidences of structural damage on the surface of seeds.

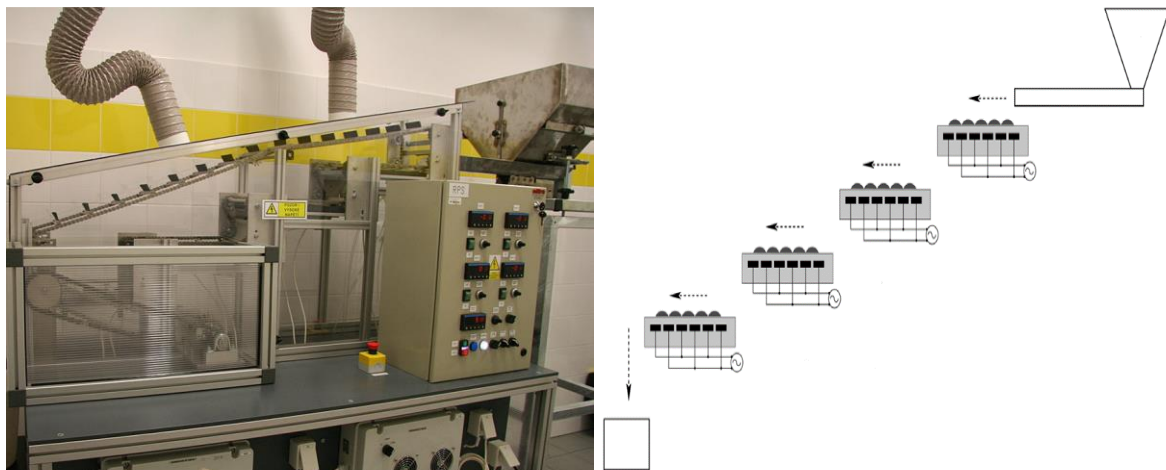

**Figure 4.** Photograph (left) and schematic (right) of DCSBD prototype for treatment of seeds [19]

This thesis is concerned with the production and characterization of PAW and its application to promote seeds germination. Two low temperature plasma devices operating at atmospheric pressure will be compared: an RF capacitively coupled source, COST Reference Microplasma Jet [20], and another jet based on a DBD configuration, thus named DBD jet. The latter device was developed at the Institute of Physics Belgrade, where this study has been conducted. After plasma treatments, variations of physicochemical properties induced in PAW, such as dissolved oxygen content, electrical conductivity, pH and concentrations of the main reactive species, were measured.

Finally, the effects of the resulting solutions in enhancing germination will be investigated, through the use of these liquids for the imbibition of two varieties of radish seeds (*Raphanus sativus var. Sativus*), chosen as model seeds.

# Chapter 2

## Materials and Methods

In this chapter two different APPJs (Atmospheric Pressure Plasma Jet) with their respective experimental setups will be presented, as well as the methods for generation of PAW and subsequent treatment of seeds. APPJs are some of the most widely used devices since they are operated at ambient temperature and pressure and allow direct treatment of temperature-sensitive materials, including biological tissues, with a targeted delivery of RONS. These plasma sources are operated with a flow of feeding gas between the electrodes, usually argon or helium, pure or with the addition of small amounts of molecular gases. Among several other parameters, the configuration of electrodes and the resulting electric field allow the distinction between cross field and parallel field jet, in relation with the direction of the feeding gas flow [21]: both groups are represented in this thesis by the COST jet and the DBD jet, respectively.

Finally instruments and procedures used for characterization of PAW, such as quantitative detection of RONS and measurements of pH, electrical conductivity and dissolved oxygen will be described.

### 2.1 COST jet

The COST Reference Microplasma Jet is a capacitively coupled plasma source. It was developed within a European Cooperation in Science and Technology action with the aim of providing all researching groups with a benchmark plasma system for the study of biomedical applications. The design consists of two symmetric, coplanar, stainless steel electrodes separated by a 1 mm gap and sealed between two quartz panes to prevent any influence of the surrounding atmosphere [20]. The electrodes and quartz panes define a  $1 \times 1 \times 30 \text{ mm}^3$  discharge volume and at the same time enable a direct optical access to the plasma region. One of the electrodes is powered by a 13.56 MHz sinusoidal voltage delivered by a commercial RF power generator (*Kurt J. Lesker Company R301*) through an impedance matching network (*Kurt J. Lesker Company AT3*).

Since in the COST jet the applied electrical field is perpendicular to the gas flow (2 slpm of pure helium for the experiments of this study), most of the charged species (high energy electrons and ions) are confined in the area between the electrodes, within the jet, and the effluent largely consists of neutral species, such as radicals and excited species [22]. Furthermore, the effects of ambient conditions on the discharge are notably reduced as compared to the important role played by the composition of the feeding gas: this is one of the main reasons and requirements for considering the COST jet as a reference plasma source.

For an easy control of experimental conditions, two internal probes are integrated into the design and a grounded casing in anodized aluminium shields the whole assembly (Fig. 5).

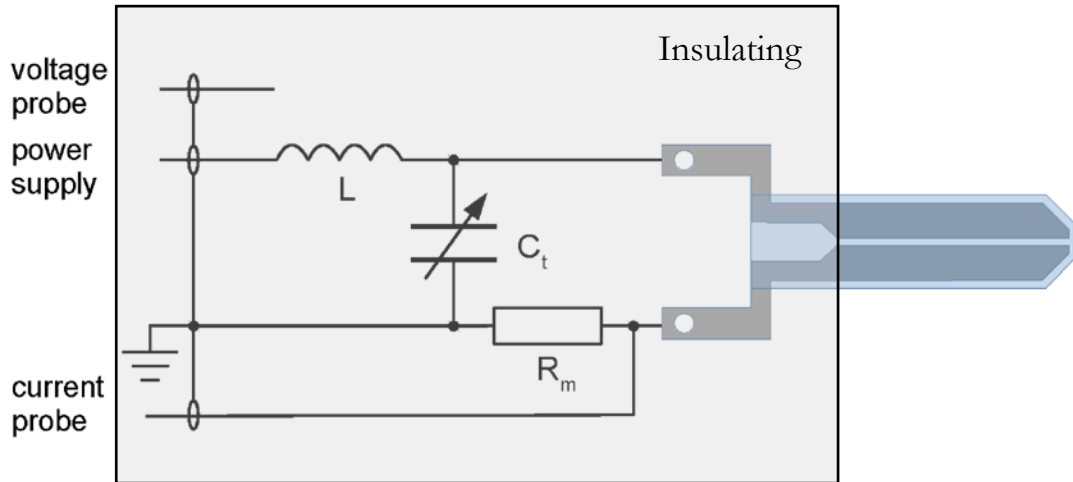

**Figure 5.** Electrical circuit scheme of COST jet including internal probes for current and voltage measurements [20]

The combined measurements of current, voltage and phase difference enable the calculation of the power delivered to the electrodes. The voltage probe consists of a wire that is capacitively coupled to the powered electrode and a calibration factor is required to obtain the real voltage difference across the electrodes: for the jet used in this study (PAC 14/2016) the calibration factor calculated by the manufacturer is  $2250 \pm 50$ . The discharge current is measured through a precision film resistor positioned between the ground-side electrode and the ground. The internal current probe actually measures the voltage drop  $U_C$  across the resistor ( $R_M = 4.7 \Omega$ ). Both internal voltage and

current probes are connected to an oscilloscope (*Tektronix MDO3024*, 200 MHz, 2.5 GS/s) using terminal connectors ( $R_T=50 \Omega$ ) to reduce signal reflections as much as possible. Therefore, the discharge current can be calculated via Ohm's law:

$$I = U_C \frac{R_M + R_T}{R_M R_T}$$

Measuring phase difference, i.e.  $\Delta\varphi = \varphi_V - \varphi_I$  ( $\varphi_V$  and  $\varphi_I$  represent the phase of sinusoidal voltage and current, respectively), with RF is not an easy task since the power dissipated in the discharge is small so the expected phase differences produced by COST jet are in the order of few degrees. At the same time any difference introduced, for example, due to the length of the cables used for connecting the probes to the oscilloscope can lead to false results. Thus, it is convenient to define a reference phase difference  $\Delta\varphi_{\text{REF}}$  with plasma not ignited, when COST jet electrodes basically form a capacitor. In this case, without the discharge, the phase difference is supposed to be  $-\pi/2$  and dissipated power should be equal to 0 W. In this study a different value of  $\Delta\varphi_{\text{REF}}$  was recorded for every level of power delivered by the generator with the feeding gas flow kept closed so that plasma ignition was avoided. Once plasma was switched on by introducing the feeding gas, the change in phase difference from  $\Delta\varphi_{\text{REF}}$  could be used to calculate dissipated power via the formula [23]:

$$P = U_{\text{rms}} \cdot I_{\text{rms}} \cdot \cos\left(\Delta\varphi - \Delta\varphi_{\text{REF}} - \frac{\pi}{2}\right)$$

Fig. 6 shows dissipated power and voltage between the electrodes as functions of the power delivered by the RF generator. The discharge ignites even with only 1 W supplied, with a voltage below 200 V. Then both voltage and dissipated power increase almost linearly with RF power, up to 3 W. For higher powers, a transition to the so-called ‘‘constriction mode’’ can be observed: the voltage drops but dissipated power strongly increases because of the sharp rise of discharge current and a bright hotspot of plasma appears at the tip of the electrodes (Fig. 7). Consequently, gas temperature rises

much above the room temperature. For these reasons, operating in this regime longer than few seconds should be avoided, otherwise the device could be damaged by the thermal load to the electrodes and the quartz panes.

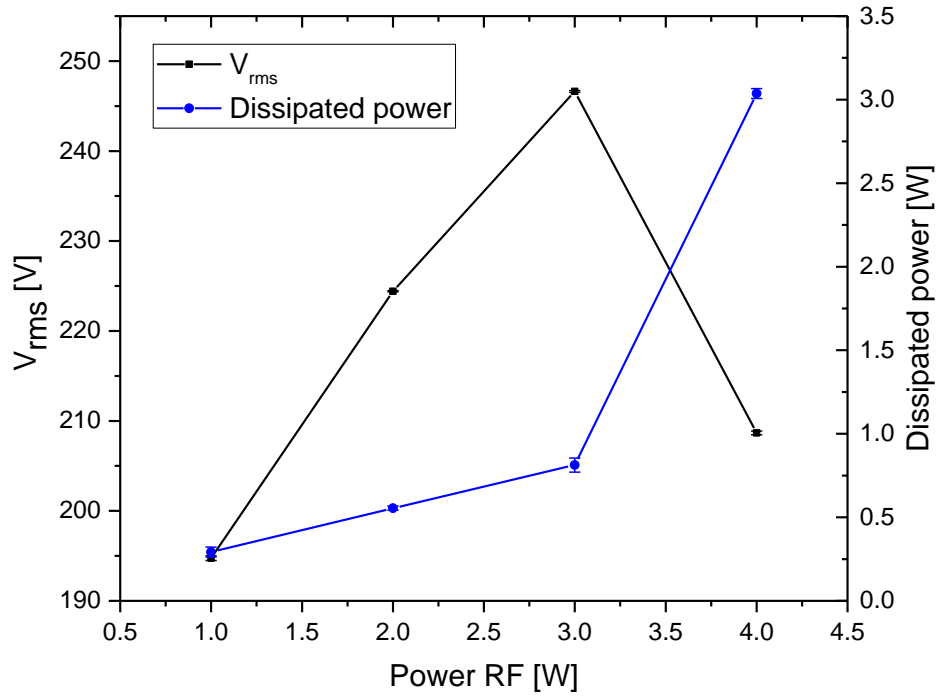

**Figure 6.** Electrical characterization of COST jet

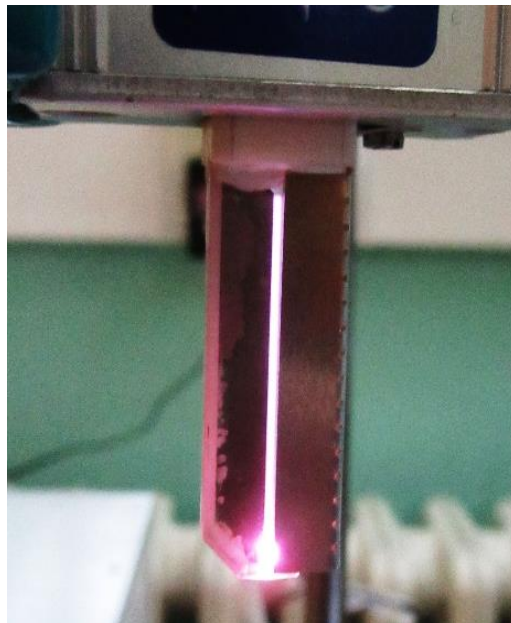

**Figure 7.** Hotspot of the “constricted mode”



## 2.2 DBD jet

The second plasma source employed in this study is a parallel field jet based on a DBD configuration. This device consists of two copper foil tape electrodes wrapped around a glass tube (4 mm inner diameter, 6 mm outer diameter). Both electrodes are 15 mm wide: the first one is placed at a distance of 5 mm from the end of the glass tube, while the other one is placed farther along the tube so as to obtain a 5 mm gap between them.

The electrode closer to the end of the tube is powered by a high voltage sinusoidal signal with the frequency of 81 kHz that is produced by a function generator (*PeakTech DDS Function Generator 4025*) and amplified by using a home-made amplifier and a HV transformer. The other electrode is connected to the ground through a 1 k $\Omega$  resistor. As can be seen from Fig. 8, the plasma is ignited between the electrodes, then propagates outside of the tube forming a plasma plume. Similarly to the COST jet, a flow of 2 slpm of pure helium was employed.

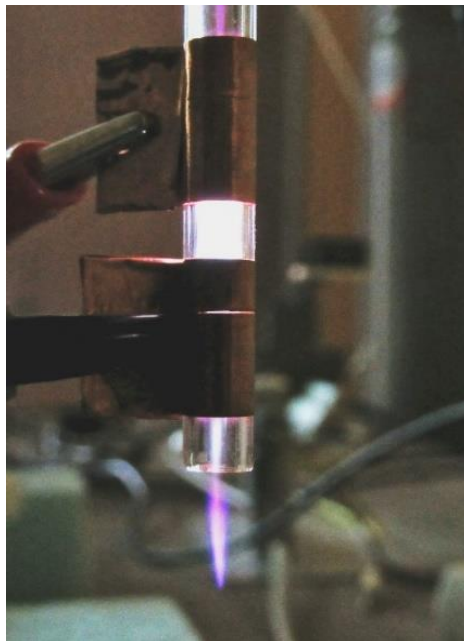

**Figure 8.** DBD jet ignited in a configuration without a target

Electrical characterization of the DBD jet was performed in the same configuration that was used for PAW production in order to perform the measurements under process conditions: a well plate filled with distilled water was positioned below

the nozzle of the jet and another copper foil tape was applied on its bottom. This target electrode was also grounded through a 1 k $\Omega$  resistor. A voltage probe (*Tektronix P6015A*) connected to the powered line provided the voltage measurement, while the currents flowing through the grounded electrode of the jet and the target electrode,  $I_{gr}$  and  $I_{tg}$  respectively, were measured by means of two probes (*Agilent N2863B*) via Ohm's law thanks to the voltage drop across the 1 k $\Omega$  resistors. Once collected the waveforms at the oscilloscope (*Keysight DSOX3024A*, 200 MHz, 4 GS/s), the calculation of either the power dissipated in plasma  $P_{gr}$  and the power delivered to the target  $P_{tg}$  can be carried out via the formula:

$$P = \frac{1}{nT} \cdot \int_{t'}^{t'+nT} V(t) \cdot I(t) dt$$

where  $T = 1/f = 1.23 \cdot 10^{-5} s$  is the period of the sinusoidal function and  $n$  represents the number of periods considered for the calculation, equal to 7 in this case.  $I(t)$  can be replaced by either  $I_{gr}$  or  $I_{tg}$  in order to obtain  $P_{gr}$  and  $P_{tg}$  respectively.

Fig. 9 illustrates the power-voltage characteristic of the DBD jet. The operative point indicated in red in the graph are obtained before breakdown.

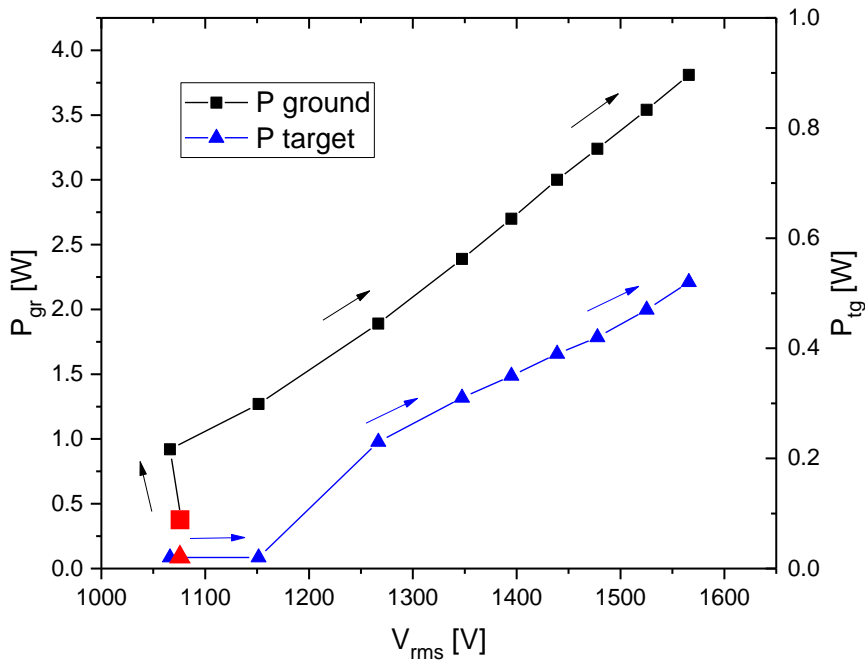

**Figure 9.** Electrical characterization of DBD jet

After plasma ignition, there is a small voltage reduction due to the current drawn by the discharge. Then, by increasing the input voltage on the amplifier, a linear rise of  $P_{gr}$  can be noticed up to maximum values close to 4 W.

The power measured at the target electrode shows a different behaviour. For voltages below 1150 V, the plasma plume cannot be observed, hence no current passes through the electrode placed at the bottom of the well, so  $P_{tg}$  is close to zero. For higher voltages, the development of a plasma plume is visible, current  $I_{tg}$  starts flowing through the distilled water and almost linear increase in  $P_{tg}$  (up to 0.5 W) can be observed.

## 2.3 PAW production and imbibition of seeds

PAW was produced by exposing distilled water placed in 24 well plates to the two above-mentioned APPJs. Many parameters of the experimental set-up play an important role in changing physicochemical properties, such as the total amount and proportion of reactive species, of the plasma-treated solution. Among the key factors we can mention the type and the flow rate of the feeding gas, the electrical characteristics of the plasma source, i.e. applied voltage and power, the original composition and volume of the solution to be treated as well as the initial distance between the tip of the jet and the upper surface of the solution and, obviously, the exposure time to plasma treatment [1].

For all treatments performed in this study, pure helium was employed as feeding gas, with a flow rate kept constant at 2 slpm by means of a mass flow controller (*Bronkhorst High-Tech*). The COST jet was operated with an input power from the RF generator of 3 W, in order to avoid instabilities and a transition to the “constriction mode”, corresponding to a rms voltage between electrodes of 245 V and an amount of power dissipated in the plasma slightly below 1 W (Fig.6). For the DBD jet the input peak-to-peak voltage was set at 4.3 kV (1.5 kV in root-mean-square values), leading to  $P_{gr} \cong 3.5 W$  and  $P_{tg} \cong 0.5 W$  (Fig.9). Treatments of 5, 10, 20 minutes and 10, 20 minutes were considered for COST jet and DBD jet respectively.

The distance between the source tip and the liquid surface (Fig. 10) was chosen after preliminary measurements carried out with analytic strips (*Merck Millipore*) to quantify plasma-induced RONS. For the DBD jet, a gap of 5 mm maximized the content of reactive species, since this configuration allowed the plasma plume to touch the liquid surface. On the other hand, for the COST jet, the maximum concentration of reactive species was found for a distance of 10 mm that proved to be more effective than a shorter gap (5 mm), probably owing to the regime of the gas flow. Indeed, with the flow rate employed in the experiments, the effluent exiting the COST jet is completely laminar and a longer path in air enables a better interaction between excited species coming from plasma region and molecules from the surrounding atmosphere, thereby resulting in a greater amount of dissolved reactive species in the solution [24].

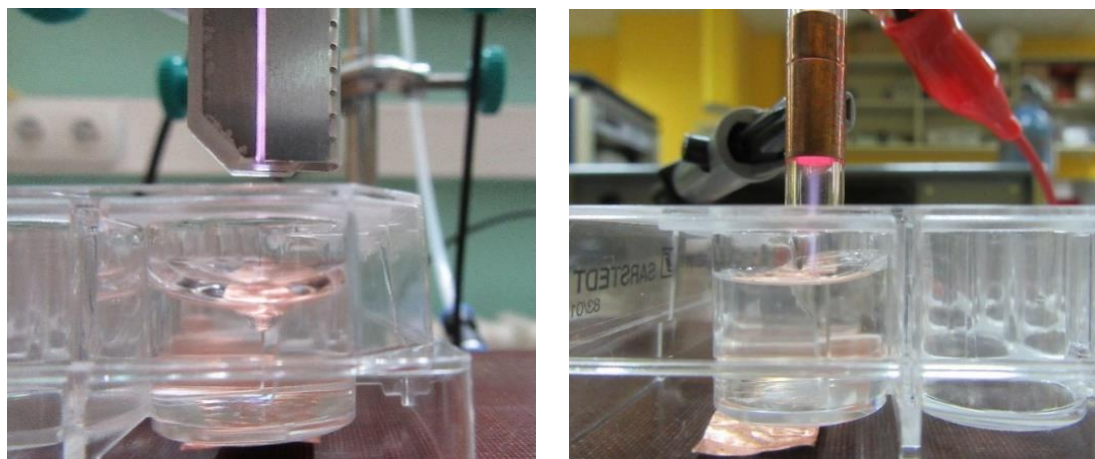

**Figure 10.** Photographs of PAW production with COST jet (left) and DBD jet (right)

The liquid volume also plays an important role; in the experiments 2.2 ml of distilled water were initially placed in a well of 24-well plate and exposed to helium plasma. This volume comes as a compromise between the amount of water required for imbibition of seeds, water evaporation during plasma treatment and the effect of liquid volume on the concentration of RONS, as it was established that these two parameters are nearly inversely related [25]. In particular, plasma exposure leads to a significant decrease in water volume: the first obvious cause is the presence of plasma above the solution, but additionally the helium flux impinging upon liquid surface modifies water vapour pressure and gives another important contribution to evaporation. The loss of water due to evaporation was quantified for every treatment time and for both plasma

sources in order to standardize the amount of PAW provided to seeds for imbibition (Fig. 11). Clearly, the longest treatment (20 minutes) with DBD jet, where plasma is in direct contact with liquid surface, resulted in a more considerable evaporation, leaving a final volume of 1.4 ml.

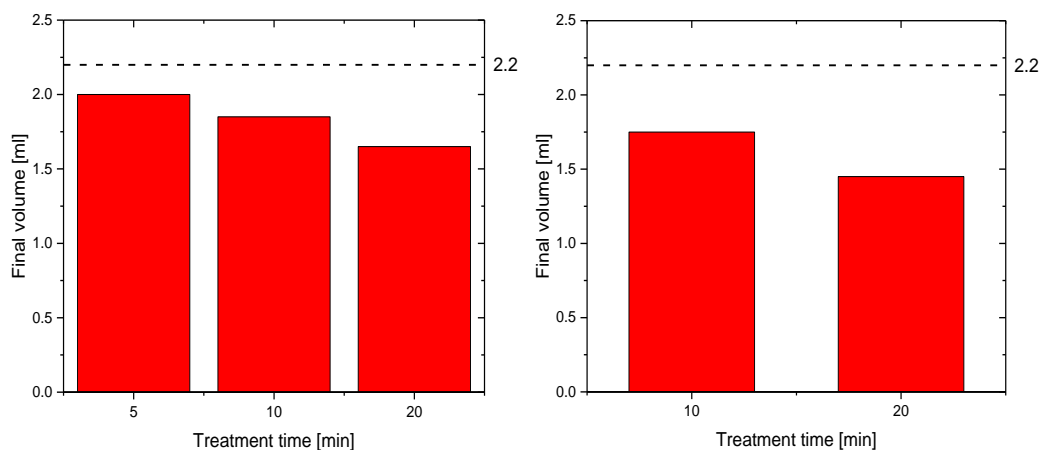
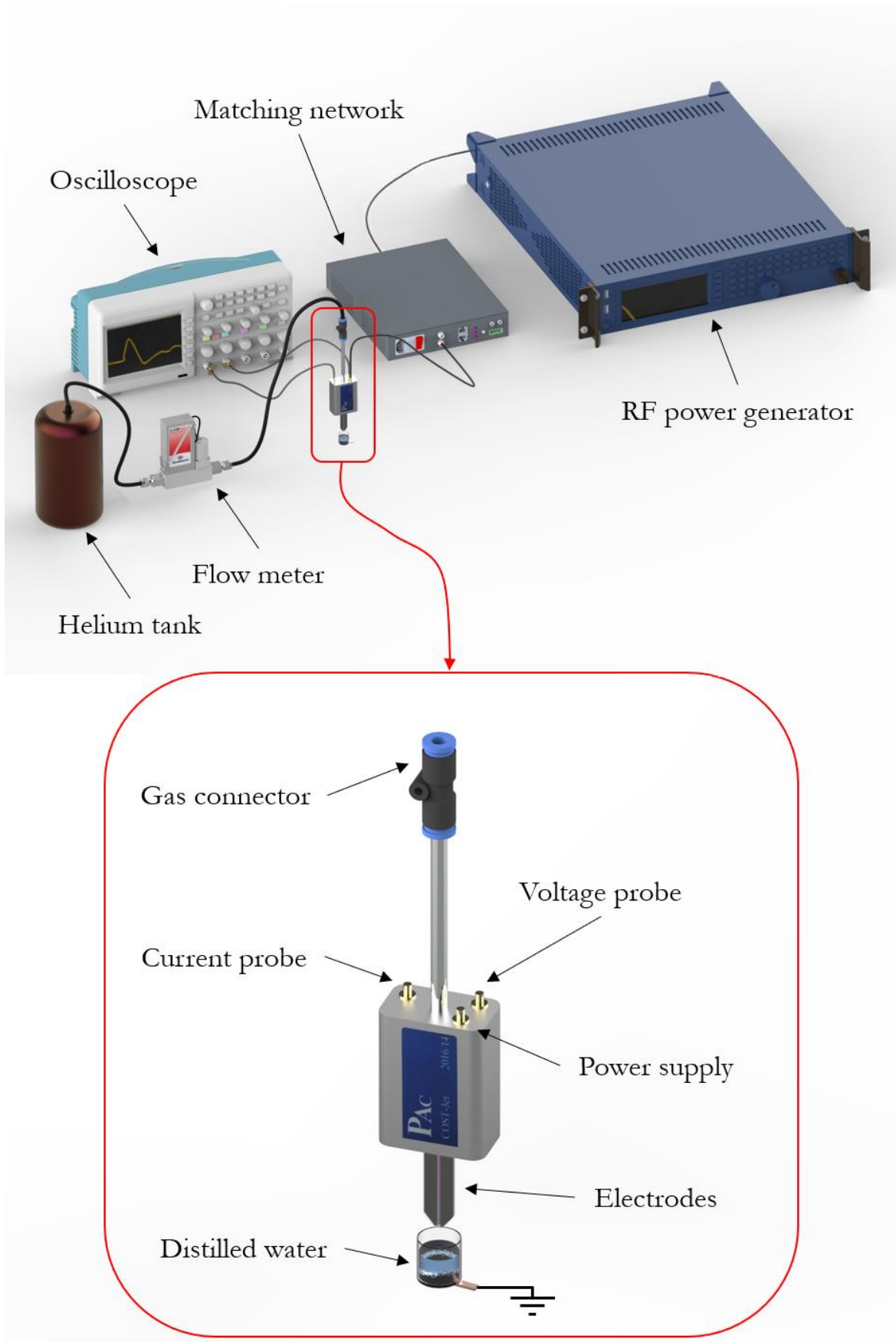

**Figure 11.** Decrease in water volume in a well after plasma exposure with COST jet (left) and DBD jet (right)

It's noteworthy that, prior to any plasma treatment, the system was run for a few minutes with the plasma ignited and without a liquid target, in order to heat-up the plasma devices and remove water vapour molecules from feeding gas tubes and the sources as much as possible. On the other hand, immediately after plasma exposure, produced PAW was either analysed or frozen in liquid nitrogen to store its physicochemical properties for following applications.

Fig. 12 and Fig. 13 summarize the experimental setups used to activate distilled water with COST jet and DBD jet respectively.

Two different varieties of radish seeds (*Raphanus sativus var. Sativus*) were considered in this study as model seeds, since this species is widely studied in literature: they were referred, according to their origin, as Italian (ITA) and Serbian (SRB) seeds. They were all stored at room temperature until use. Every batch consisted in 40 radish seeds placed into a 6 cm diameter Petri dish on a layer of filter paper. The proper germination process was conducted at the Institute for Biological Research “Siniša Stanković” in Belgrade, in controlled conditions of temperature ( $23 \pm 2$  °C) and under 16/8 light/dark regime.



**Figure 12.** Schematic of the experimental setup for treatments with COST jet

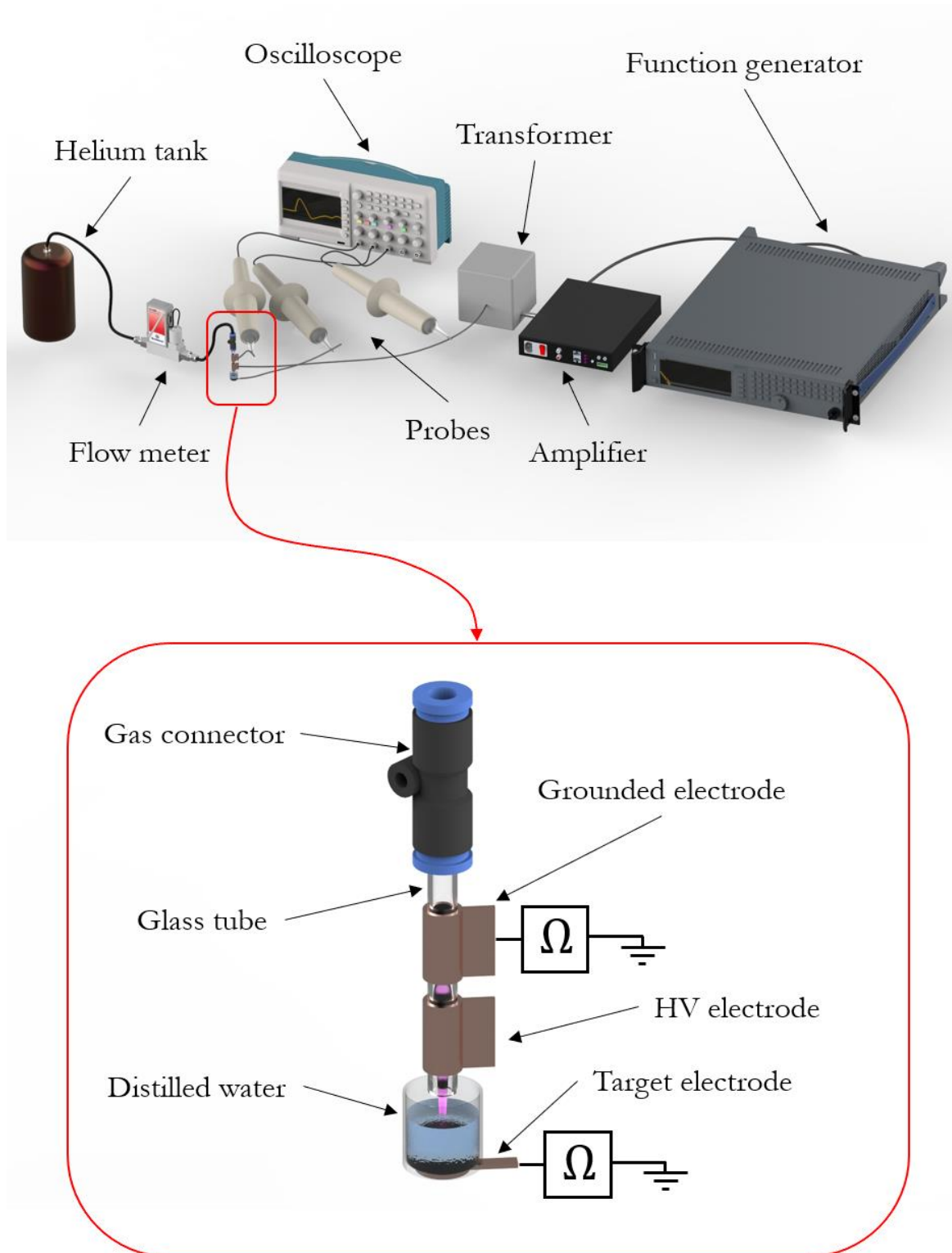

**Figure 13.** Schematic of the experimental setup for treatments with DBD jet

A volume of 1.4 ml of liquid, corresponding to the lowest amount of PAW left after plasma exposure, was added *una tantum* to each Petri dish to trigger germination. In a preliminary test performed with untreated water, it was demonstrated that this amount of liquid is sufficient for such a number of radish seeds to obtain typical germination rates. In total 48 batches were considered in this study:

- 3 replicates for each plasma source, seed variety and treatment time, imbibed with Plasma Activated Water → 30 dishes
- 3 replicates for each variety of seeds soaked in distilled water as control batches → 6 dishes
- 3 replicates for each variety of seeds and for two different levels of concentration of hydrogen peroxide solution in distilled water (5 mg/l and 25 mg/l [H<sub>2</sub>O<sub>2</sub>]), corresponding to the lowest and highest levels of concentration detected after plasma exposure in PAW, as positive control batches → 12 dishes

Positive control batches are required to assess the synergistic effects of plasma-induced RONS, since very often the blend of reactive species generated by plasma treatment is more effective than the individual use of chemical or physical agents [26]. Otherwise, if the mere addition of hydrogen peroxide to distilled water resulted in the same or better effects than plasma treatments, then it would represent a simpler and cheaper solution to enhance seed germination.

Tests to evaluate germination efficiency were carried out by manually counting germinated seedlings at 4-hour intervals, until the 32nd hour after imbibition. This time span was estimated to be sufficient for germination monitoring of both variety of seeds. The seeds were considered to be germinated when radicle emergence was approximately 2 mm. Two main parameters were taken into account to study the effects of two different plasma sources on germination performance: the final germination percentage, calculated as the ratio between germinated seeds and the total number of treated seeds multiplied by 100, indicates seeds viability, while the median germination time represents the germination halftime of seeds (i.e. the timeframe needed for 50% of the seeds lot to achieve germination) or germination rate and it is more related with germination kinetic.



## 2.4 Characterization of PAW

Evaluating variations induced by plasma exposure on the physicochemical properties of treated solutions is paramount to understand their relationship with biological results. For characterizing PAW produced by the two described plasma jets, a set of few parameters was chosen: pH, electrical conductivity, dissolved oxygen and concentrations of the major long-lived species, i.e. hydrogen peroxide ( $\text{H}_2\text{O}_2$ ), nitrite ( $\text{NO}_2^-$ ) and nitrate ( $\text{NO}_3^-$ ) ions.

Dissolved oxygen was measured by means of a DO meter (*Hanna Instruments HI2004*): the probe (*HI764080*) consists of a cylinder filled with a concentrated solution of potassium chloride and closed at its lower extremity by a PTFE membrane permeable to gases. When a known voltage is applied between the platinum cathode and the silver anode, a current proportional to  $\text{O}_2$  concentration is established. Conductivity and pH measurements were performed with a pH and EC meter (*Hanna Instruments HI5521* equipped with *HI1131B* and *HI76312* electrodes): pH values are obtained by measuring the voltage drop across a glass membrane due to different concentrations of  $\text{H}^+$  ions in electrolyte solution, while for the conductivity, a known voltage is applied between two electrodes and the established current is measured. Since the amount of liquid required for these measurements was in the order of 5-6 ml, 3-4 plasma treatments were necessary to achieve the desired volume of PAW, depending on plasma source used and exposure time considered. Thus plasma-treated water samples were frozen in liquid nitrogen right after each treatment to keep their properties and then defrosted and gathered in a single vessel, providing the adequate volume for measurements.

The long-lived plasma-generated species transferred into the liquid from the gaseous phase or formed in the liquid were quantified through spectrophotometric techniques. Preliminary semiquantitative tests were performed with analytic strips only to choose the most efficient experimental setup, but these results will not be reported here. According to Lambert-Beer law, the concentration  $c$  of a given species is related to the absorbance  $Abs$  at a certain wavelength  $\lambda$  via the formula:

$$Abs_{\lambda} = \varepsilon_{\lambda} \cdot \ell \cdot c$$

where  $\epsilon_{\lambda}$  is the molar absorptivity of the considered species at  $\lambda$  and  $\ell$  represents the optical path length. Actually, since the determination of  $\epsilon_{\lambda}$  is a challenging task because of its strong dependence from experimental conditions, an alternative approach was followed: solutions with known concentrations were employed to obtain a calibration curve by linear fitting of the experimental values of absorbance for each species considered (Fig. 14). Then, from the resulting slopes, it was possible to calculate unknown concentrations generated after plasma exposure.

Measurements of absorbance were performed by means of a UV/Visible spectrophotometer (*Beckman Coulter DU 720*) equipped with a halogen tungsten lamp for visible spectrum and a deuterium lamp for ultraviolet spectrum: therefore, this device is able to work on wavelengths ranging from 190 to 1100 nm. Quartz cuvettes, with an optical path length of 10 mm, were employed to guarantee a high transmittance for the wavelength range studied. As a background, measurements of the absorbance of a “blank” cuvette filled with distilled water were performed.

Generally, colorimetric methods are based on addition of one or more chemical reagents to a plasma-treated solution; the chemical agent then reacts with a specific molecule present in PAW, forming a spectrophotometrically detectable compound. The concentrations of nitrite and nitrate ions were determined using Spectroquant® Test for Nitrites and Nitrates (*Merck 1.14776* and *1.09713*) at a wavelength of 525 nm and 340 nm respectively. These two methods actually provide the concentrations of NO<sub>2</sub>-N and NO<sub>3</sub>-N, but they can be easily converted through known coefficients [27]:

$$[\text{NO}_2] = 3.285 * [\text{NO}_2\text{-N}]$$

$$[\text{NO}_3] = 4.427 * [\text{NO}_3\text{-N}]$$

Hydrogen peroxide concentration in PAW was quantified employing the Titanium (IV) oxysulphate method (*Sigma-Aldrich 89532*) at the wavelength of 407 nm [28]. For each method utilized, a reaction time of ten minutes was required to allow the reagents to complete the reactions and obtain stable shades. After this time, resulting solutions were poured into quartz cuvettes, which were then positioned in the sample-holder of the spectrophotometer, ready for absorbance detection.

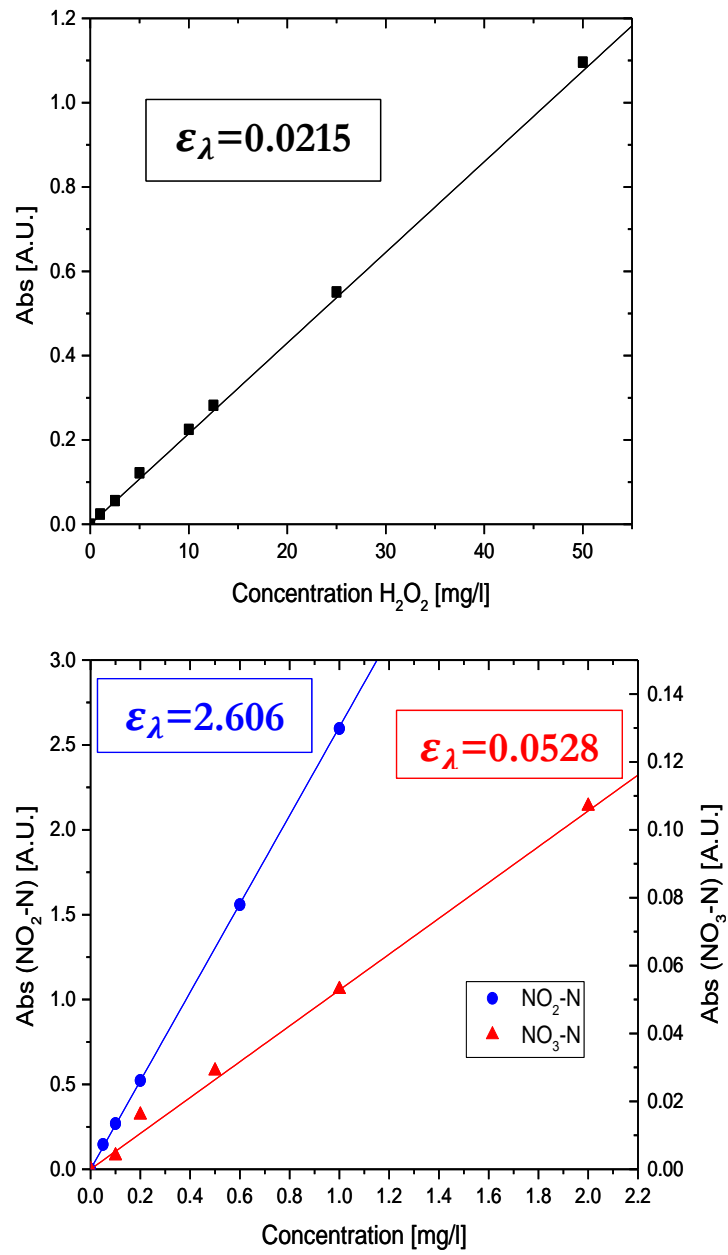

**Figure 14.** Calibration plots for hydrogen peroxide (top) and nitrites and nitrates (bottom)

# Chapter 3

## Results and Discussion

In this chapter, the results obtained in this study will be presented and discussed. Firstly, values related to characterization of plasma-activated water, such as pH, electrical conductivity, concentration of dissolved oxygen and quantitative detection of long-lived reactive species, will be reported. The last section will be dedicated to biological results and the effects of PAW on seeds germination performance will be analysed.

### 3.1 Physicochemical properties of PAW

Dissolved oxygen content analysis measures the concentration of gaseous oxygen ( $O_2$ ) in aqueous solutions. The amount of dissolved molecular oxygen represents a very significant parameter in seed germination, as this process is particularly sensitive to oxygen deficiency. The consumption rate of  $O_2$  especially depends on the stage of germination: during radicle protrusion, for instance, seeds absorb oxygen much faster, as compared to the early phase of imbibition [16]. Fig. 15 depicts variations in dissolved oxygen content due to exposure of distilled water to the COST jet and the DBD jet. The behaviour is similar for both plasma sources: from the initial value slightly higher than 70 % (5.7 ppm), corresponding to the content in untreated distilled water, a sharp fall to 45 % (3.8 ppm) can be observed at the first stages of plasma treatment, mainly due to the so-called sparging effect. The jet of helium flowing above the liquid surface reduces the partial pressure of  $O_2$  and its solubility in water, allowing molecular oxygen to leave the aqueous phase, in accordance with Henry law on partial pressures. On the other hand, after the first drop,  $O_2$  concentration started to increase reaching similar values after 20 minutes of treatment for both devices (55 %, 4.5 ppm). This was probably due to the prolonged exposure of PAW to the surrounding atmosphere but another possible contribution to counterbalance the depletion mechanism could be

given by the formation of O<sub>2</sub> by-products from the reactions involving plasma-generated RONS in the solution [10].

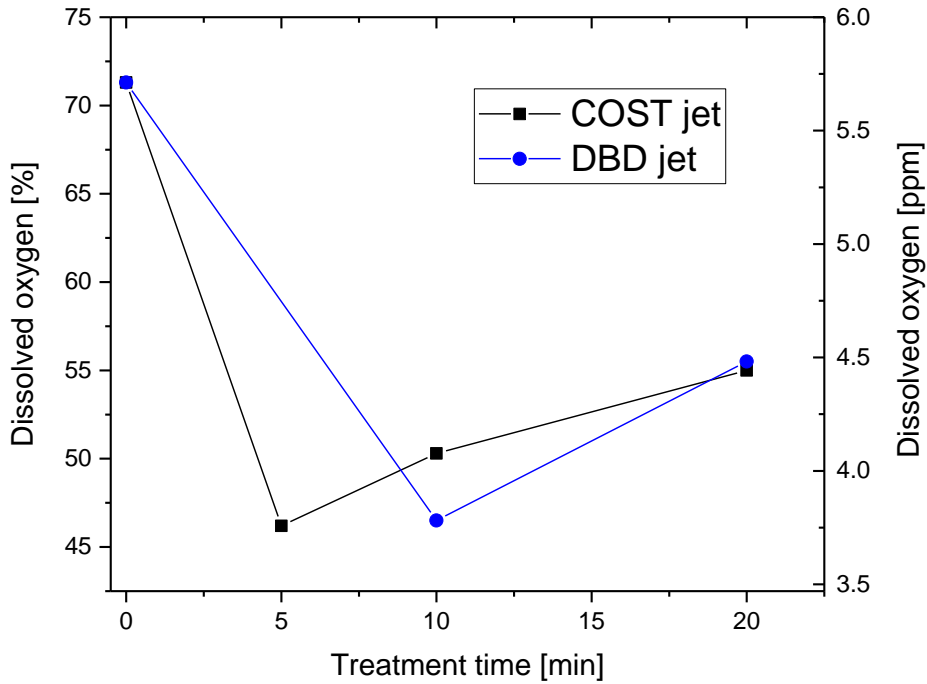

**Figure 15.** Variations of dissolved oxygen content with plasma treatment time

Electrical conductivity and pH are related parameters. pH represents the concentration of H<sup>+</sup> ions of a solution, whereas conductivity is a measure of the ability of a solution to facilitate an electric current to flow through it. The variation of conductivity is associated with an accumulation of ions in PAW: the gaseous RONS produced during plasma treatment readily dissolve into the liquid phase and resulting ions strongly affect this parameter. Besides providing a quantitative measure of accumulated H<sup>+</sup> ions in PAW, pH also plays a key role in the process of germination and plant growth: seeds performances are negatively influenced if values of pH are below a certain threshold, specific to each species. Conductivity and pH variations induced by plasma treatment are shown in Fig. 16 and Fig. 17 respectively.

Electrical conductivity does not seem to represent a crucial factor in the comparison of the two plasma sources, as the trends and the values are almost identical. The starting value, measured for distilled water, was 1.1 μS/cm and both jets reached values above 8 μS/cm after 20 minutes of plasma exposure. The only difference is at 10 minutes, when conductivity induced by the COST jet was slightly lower.

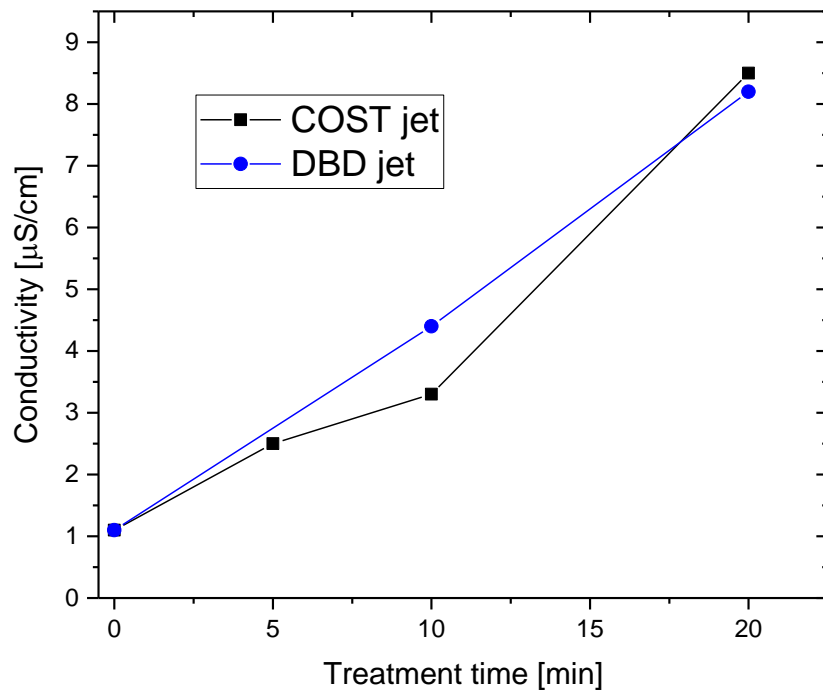

**Figure 16.** Variations of electrical conductivity with plasma treatment

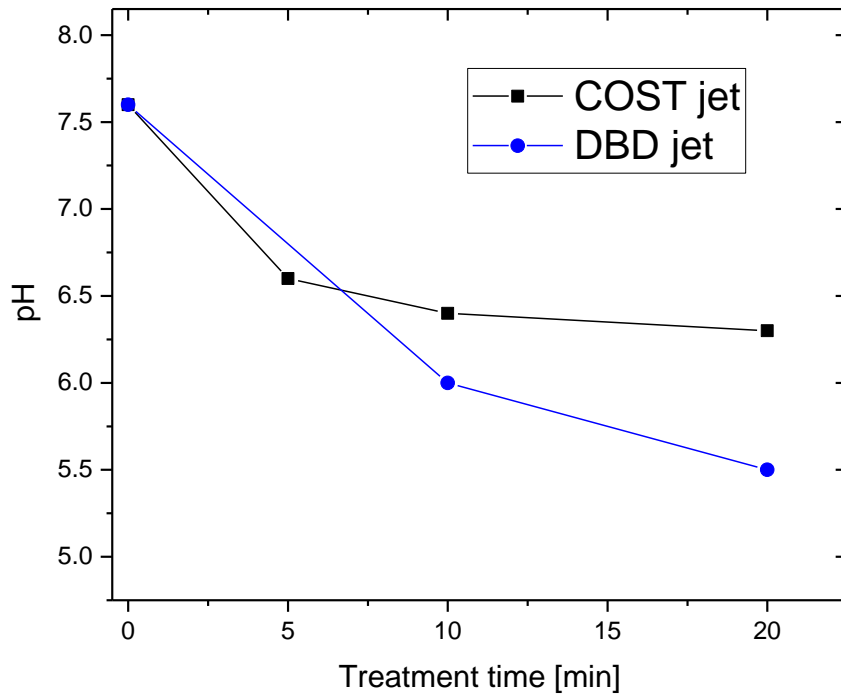

**Figure 17.** Variations of pH with plasma treatment

Conversely, pH results show some differences: from 7.6 of untreated water, both sources induced a decrease of pH values, a clear evidence of ionization of nitrogen compounds in PAW. The final value reached after 20 minutes of treatment with the DBD jet was 5.5, whereas for the COST jet pH reaches 6.3. This difference can probably be explained with the contrasting electrodes configurations of the two analysed plasma sources: unlike the COST jet, a cross field jet where plasma is confined within the electrodes and only afterglow can interact with liquid surface, in a parallel field jet, like the DBD jet, the discharge is in direct contact with the solution.

Another contribution to pH variations could be provided by CO<sub>2</sub>: with prolonged exposure to surrounding air, carbon dioxide naturally present in the atmosphere dissolve into liquid phase and cause a further acidification of the solution. Taking everything into account, overall pH variations after plasma treatments do not seem so significant to induce detrimental effects on the process of germination of radish seeds, even though their pH threshold is unknown.

As previously mentioned, hydrogen peroxide (H<sub>2</sub>O<sub>2</sub>), nitrites (NO<sub>2</sub>) and nitrates (NO<sub>3</sub>) are considered the main long-lived RONS that remain in solution after plasma treatment. Moreover, it is now well established that they play a key role in the achievement of the major events of seeds life, such as germination [29]. For this reason, a quantitative measurement of these reactive species could represent a good index for characterization of plasma sources, with respect to the biological effects associated with PAW. Concentration of hydrogen peroxide measured after plasma treatments is reported in Fig. 18. Fig. 19 is dedicated to concentration of nitrites and nitrates. For the results concerning the concentrations of the reactive species, an error bar equal to 15% was considered.

As can be observed in Fig. 18, both trends were increasing but the COST jet proved to be much more effective in producing hydrogen peroxide: after 10 minutes of treatment the concentration induced by the COST jet was twice the amount produced by the DBD jet (10.8 mg/l against 5.7 mg/l). The difference became even larger for longer exposure time, when a value slightly above 25 mg/l was reached with the COST jet, whereas the concentration achieved with the other jet stopped at 8 mg/l. These results were also used as a reference in the choice of two standard concentrations for

positive controls. The chosen values of 5 mg/l and 25 mg/l nearly corresponded to the lowest and highest levels measured after plasma exposure. The purpose was as follows: although hydrogen peroxide content was by far the highest among reactive species present in PAW, it was critical to demonstrate that nitrite and nitrate ions, even with lower concentrations, contributed to synergistic effects on biological targets.

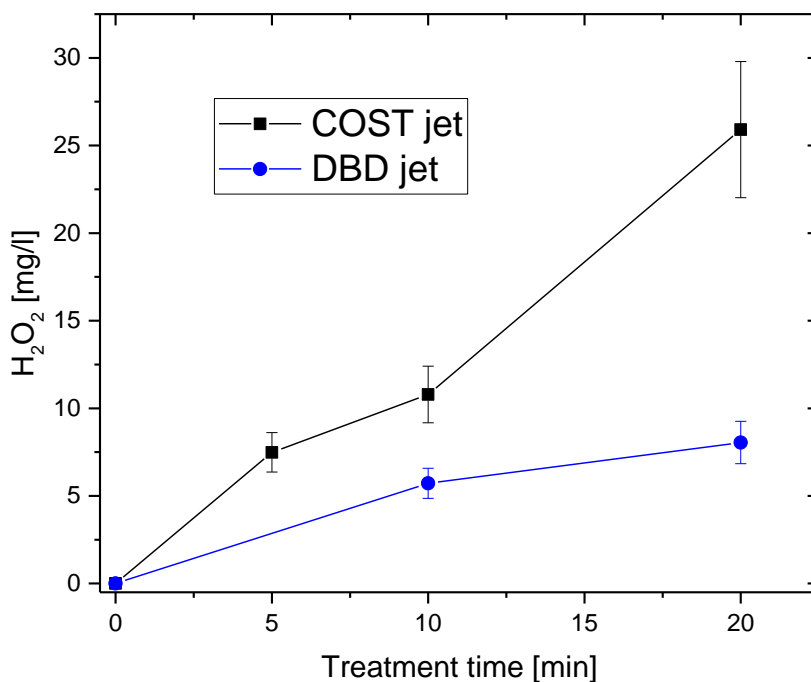

**Figure 18.** Variations of hydrogen peroxide concentration with treatment time

Presented in Fig. 19, concentrations of nitrates and nitrites in PAW were much lower as compared to detected hydrogen peroxide, as already mentioned. In particular, variations in nitrates content induced by the COST jet are hardly explicable since a non-monotone trend could be expected for NO<sub>2</sub> (nitrites may react into more stable nitrates), but not for NO<sub>3</sub>: it is likely that the first operative point, after 5 minutes of treatment, was affected by an error in measuring method and thereby overestimated. After 10 minutes concentrations of nitrates were almost identical (~1 mg/l) for both jets, while at 20 minutes 2.3 and 1.4 mg/l were reached by the COST jet and the DBD jet respectively.

In comparison to nitrates lower concentrations were detected for nitrites: a maximum content of 0.2 mg/l was reached after 5 minutes with the COST jet and with treatment of 20 minutes for the DBD jet. These results are probably may be slightly



diminished due to the fact that, under acidic conditions, nitrites react with hydrogen peroxide to generate peroxynitrite, which subsequently converts into stable nitrate ions [30]. At the same time, the colorimetric method required the further addition of sulfuric acid to reach the adequate pH to detect nitrites. Thus, perhaps actual concentration of  $\text{NO}_2^-$  could be slightly greater because some of them had reacted owing to the acid environment and, of course, were no longer detectable. Nevertheless, independent semiquantitative measurements conducted with analytic test strips confirmed very low content of nitrites produced by plasma treatment, as final concentrations were always under the lower detection limit of 0.5 mg/l.

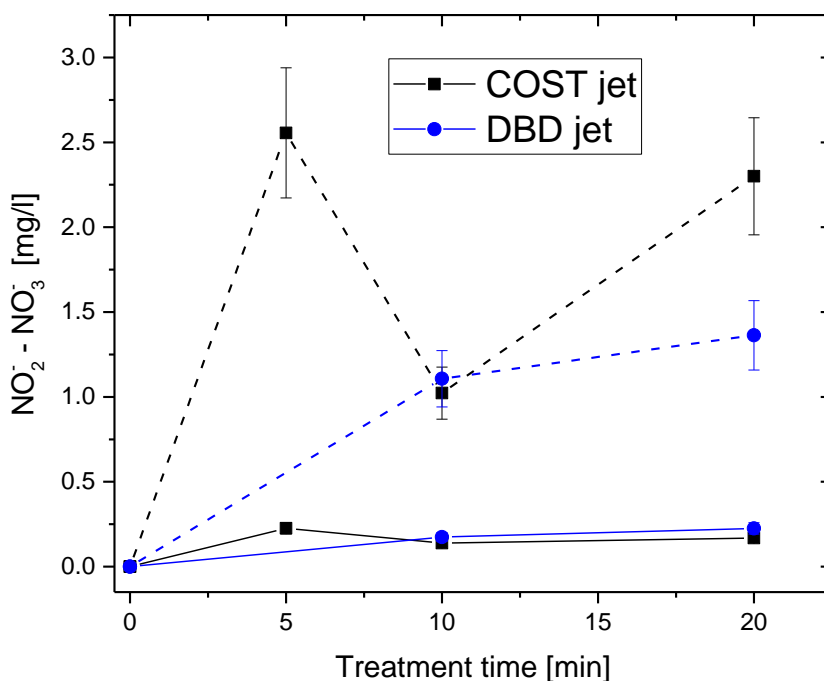

**Figure 19.** Variations of nitrites (solid lines) and nitrates (dashes) concentration with treatment time

### 3.2 Seeds germination

The final step of this study consists in the evaluation of PAW potential in the promotion of germination. Plasma-produced solutions, along with positive and negative controls, were employed for imbibition of radish seeds, chosen as model seeds for these experiments. Results concerning seeds germination are reported graphically as mean values  $\pm$  standard deviations, calculated from three replicates for each treatment condition. In presenting and discussing the results obtained with the analysis of

germination dynamics, three main factors are involved: the type of APPJ used to generate PAW, i.e. COST jet or DBD jet, the exposure time used to activate distilled water (from 5 to 20 minutes depending on the plasma source employed) and, lastly, the variety of radish seed considered for each experiment (Italian or Serbian).

Results obtained by imbibition of Italian radish seeds in PAW produced by the COST jet are shown in Fig. 20.

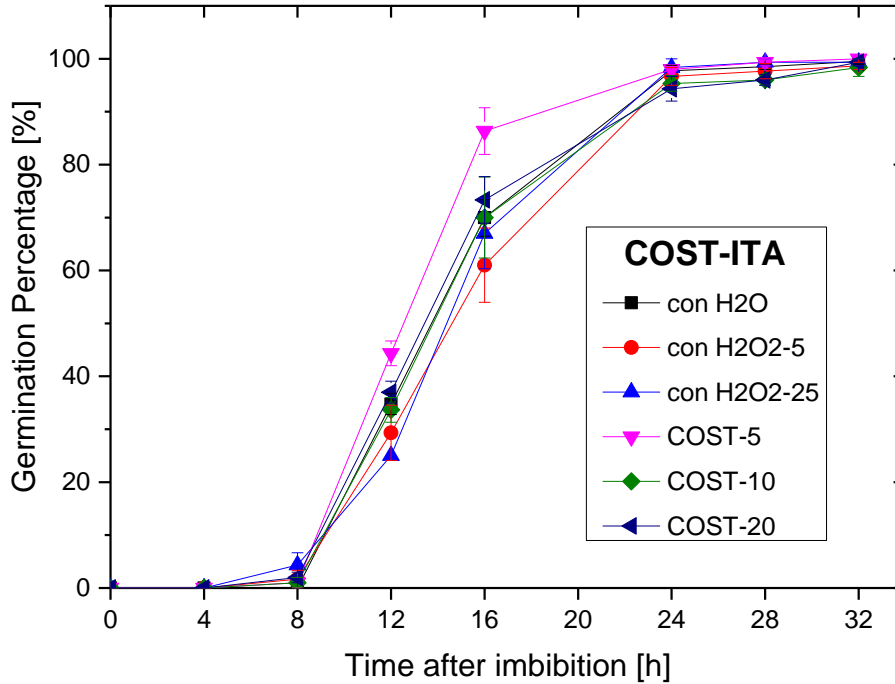

**Figure 20.** Italian seeds treated with PAW obtained with COST jet

All curves reached a plateau close to 100% of germination percentage after 24 hours, regardless of the liquid employed for imbibition. Even if the final germination percentage was similar, what happened before is more interesting: PAW treated for 5 min (COST-5) induced the fastest kinetic of germination as compared to all other liquids including COST-10 and COST-20. In particular, considering the median germination halftime, for COST-5 it was below 14 hours, while the seeds imbibed with other liquids reached that threshold after 17 hours. Positive controls, i.e. solutions of hydrogen peroxide in distilled water (H<sub>2</sub>O<sub>2</sub>-5 and H<sub>2</sub>O<sub>2</sub>-25), induced even worse effects than untreated water (H<sub>2</sub>O), albeit differences were quite small.

Experiments with the COST jet and Serbian seeds led to the outcomes shown in Fig. 21. Again, COST-5 seems to improve germination, as compared to longer plasma

treatments, even though differences were not statistically relevant as error bars were overlapping. The final germination percentage achieved with COST-5 and COST-10 was slightly above 70%, while COST-20 with 65% induced even worse germination than control with distilled water (70%). Unlike for the Italian variety, the best results for Serbian seeds were obtained with solutions containing hydrogen peroxide, where the final germination percentage was 74% and 80% with H<sub>2</sub>O<sub>2</sub>-5 and H<sub>2</sub>O<sub>2</sub>-25 respectively: this confirms that even different varieties of the same species react with RONS can result in contrasting outcomes.

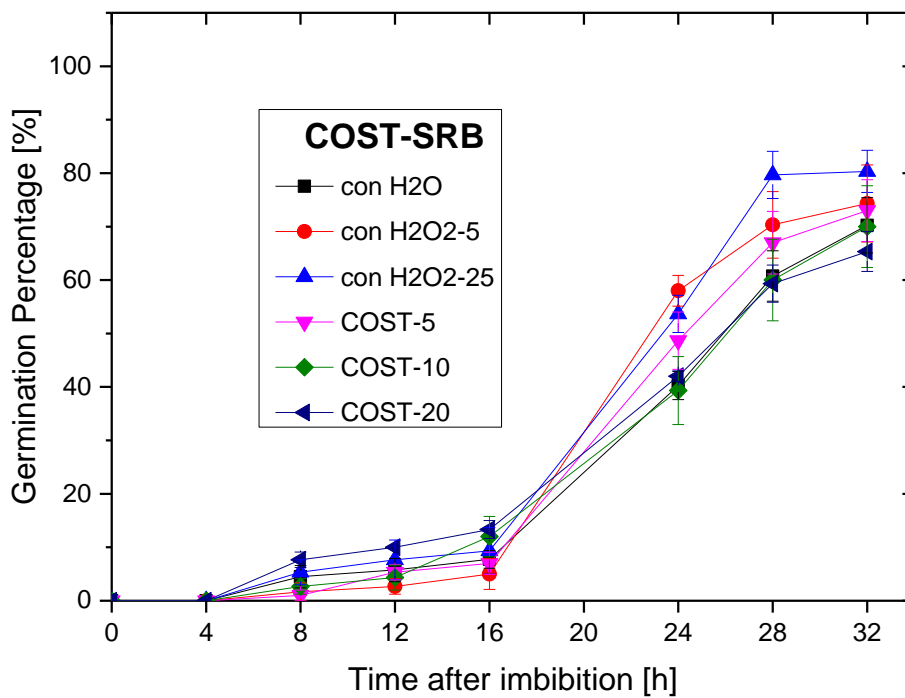
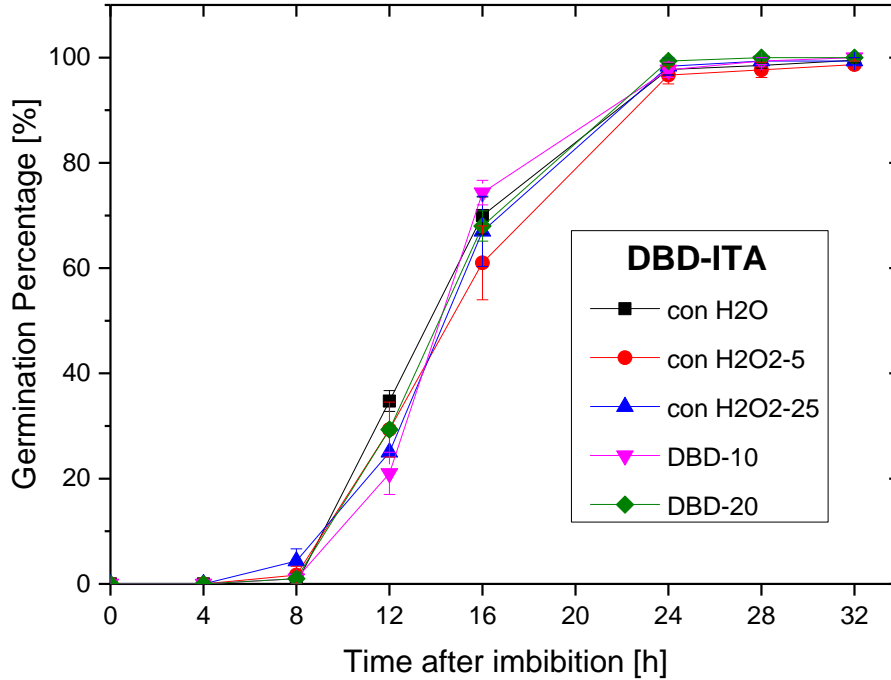

Figure 21. Serbian seeds treated with PAW obtained with COST jet

PAW produced with the DBD jet does not seem to be effective on Italian seeds: in Fig. 22 every curve almost overlapped through the complete timespan of germination process without relevant differences. A plateau over 95% of germination was reached within 24 hours from the imbibition and median germination time was around 17 hours, regardless of the liquid used.

The last combination of Serbian seed variety treated with PAW obtained with the DBD jet also represents the most interesting case in this study, since a quite significant improvement was induced by plasma-treated solution, as Fig. 23 illustrates. In particular, PAW treated with the DBD jet for 20 minutes (DBD-20) resulted to be

the best solution in enhancing seeds germination: it showed faster dynamics with a germination halftime ( $\sim 23$  h) at least one hour shorter as compared to the values obtained with other liquids.



**Figure 22.** Italian seeds treated with PAW obtained with DBD jet

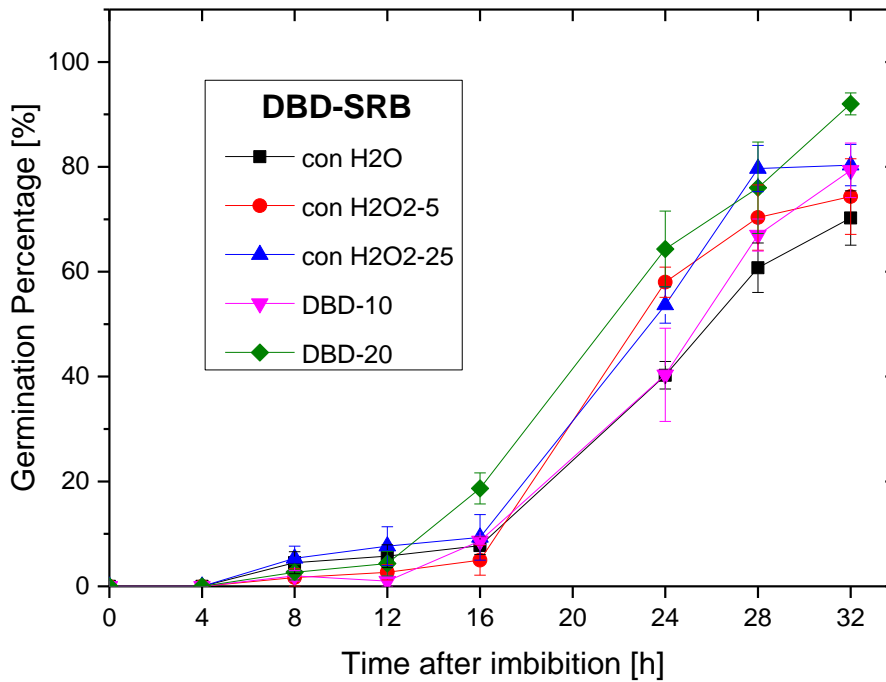

**Figure 23.** Serbian seeds treated with PAW obtained with DBD jet

The final percentage of germination appears to be the most surprising result, since DBD-20 could reach 92%, whereas DBD-10 and untreated control reached 79% and 70% respectively. This means that more than 20% of the seeds lot, that otherwise would be lost, can be recovered and successfully achieved the germination. Furthermore, this improvement cannot be attributed exclusively to hydrogen peroxide because values obtained with positive controls, 5 mg/l and 25 mg/l of H<sub>2</sub>O<sub>2</sub>, were lower, with final germination percentages equal to 74% and 80% respectively. In this case, the synergistic effect induced by the blend of plasma-generated reactive species was more relevant than the individual use of its main component.

Generally, Italian seeds have a high native efficiency, as even seeds imbibed with untreated water almost reached the full germination (99%). The dynamics of germination are also really fast, thereby it is unlikely to obtain significant improvements with these seeds. As observed by Judée et al. [18], if kinetic of germination is faster than signalling reactions, the short-term beneficial effects of PAW cannot be expected to be much relevant.

On the other hand, Serbian seeds have a slower germination rate and a lower final germination percentage. Hence, it is easier to observe some improvements of their performance induced by PAW or solutions with hydrogen peroxide. Furthermore, for Serbian seeds H<sub>2</sub>O<sub>2</sub> positive controls generally improved dynamics of germination, as compared to untreated H<sub>2</sub>O controls, while for Italian seeds they led to similar, or even worse, results.

# Chapter 4

## Conclusions and Outlooks

In this study distilled water was treated by means of two plasma jets operated at atmospheric pressure with pure helium as feeding gas. The jets have different electrode configurations: the COST jet is a cross field jet, where electrons and ions are mostly confined within the electrode region. The second source is a parallel field jet based on a DBD configuration. Here, if power supplied by the generator is high enough, a plume of plasma can exit the jet nozzle and interact with surrounding air and directly with a liquid target.

Physicochemical properties of PAW were measured after plasma treatments. Variations in dissolved oxygen content due to the treatment time were similar for both sources, with a sharp drop due to the helium flux impinging on liquid surface for treatments of 5 min and small increase related to longer exposure to plasma. Trends of electrical conductivity were comparable as well: the rise was almost linear with treatment time for both cases owing to the fact that plasma-generated RONS dissolved in aqueous phase. In contrast to the conductivity measurements, the DBD jet caused a greater decrease in pH, if compared with the other plasma source, probably because plasma was in direct contact with the liquid surface. Anyway, the level of acidity obtained did not appear so relevant to negatively influence seeds germination.

The main long-lived reactive species in PAW were quantitatively measured by means of spectrophotometric methods. Both plasma jets almost selectively produced hydrogen peroxide, that was by far the species with the highest concentration, especially with the COST jet. The content of nitrates produced with plasma exposure was in the order of few mg/l, whereas production of nitrites was even lower.

Lastly, the effects induced by PAW on the germination of radish seeds were investigated, and two varieties of seeds were compared. The final effect on germination have a clear dependence on three parameters:

- variety of seeds considered;

- plasma source employed in PAW production;
- exposure time to plasma treatment.

Italian seeds are characterised by high germination rate and viability, so it was hard to improve their performances: only PAW treated with the COST jet for 5 minutes induced a faster kinetic, but the final germination percentage reached 100% within 24 hours from imbibition, regardless of the liquid used for imbibition. From our point of view, Serbian seeds are better candidates for PAW treatments since they initially had smaller rate of germination, lower viability and consequently a wider margin for improvement. In this sense, the best results were obtained when plasma-treated solution exposed to the DBD jet for 20 minutes was employed for imbibition: it led to an absolute gain higher than 20%, as compared to untreated distilled water, and more than 10% on the value reached with H<sub>2</sub>O<sub>2</sub> control.

A general rule arises from these results: plasma treatments are product-specific, so each process and each device needs to be calibrated and tailored for each species, or even for each variety of seeds. The success of plasma-assisted technologies in agriculture, or in other words, their translation from laboratories to industry, will depend on their future scaling-up and their capacity to work continuously. Before plasma-agricultural techniques can be widely applied on an industrial scale, we must understand the underlying mechanisms of the interaction between plasma-induced gaseous and aqueous species and biological targets as well as assessment of issues related to safety and quality aspects of plasma-treated. Given the highly multidisciplinary nature of this field, a close collaboration between plasma scientists, plant biologists, agricultural experts and food technologists is required to achieve these goals.

# Bibliography

- [1] R. Thirumdas, A. Kothakota, U. Annapure, K. Siliveru, R. Blundell, R. Gatt, and V. P. Valdramidis, **“Plasma activated water (PAW): Chemistry, physico-chemical properties, applications in food and agriculture”**, *Trends in Food Science & Technology*, vol. 77, pp. 21–31, (2018).
- [2] Food and Agriculture Organization of the United Nations, **“The future of food and agriculture – Trends and challenges”**, (2017).
- [3] L. Sivachandiran, and A. Khacef, **“Enhanced seed germination and plant growth by atmospheric pressure cold air plasma: combined effect of seed and water treatment”**, *RSC Adv.*, vol. 7, pp. 1822–1832, (2017).
- [4] N. Puač, M. Gherardi, and M. Shiratani, **“Plasma agriculture: A rapidly emerging field”**, *Plasma Process Polym.*, 15:e1700174, (2018).
- [5] R. Thirumdas, A. Kothakota, K. C. S. Sai Kiran, R. Pandiselvam, and V. U. Bhanu Prakash, **“Exploitation of Cold Plasma Technology in Agriculture”**, *Advances in Research*, vol. 12(4), pp. 1-7, (2017).
- [6] M. Ito, J-S. Oh, T. Ohta, M. Shiratani, and M. Hori, **“Current status and future prospects of agricultural applications using atmospheric-pressure plasma technologies”**, *Plasma Process Polym.*, 15:e1700073, (2018).
- [7] R. Thirumdas, C. Sarangapani, and U. Annapure, **“Cold Plasma: A novel Non-Thermal Technology for Food Processing”**, *Food Biophysics*, vol. 10, pp. 1-11, (2015).
- [8] L. K. Randeniya, and G. J. J. B. de Groot, **“Non-Thermal Plasma Treatment of Agricultural Seeds for Stimulation of Germination, Removal of Surface Contamination and Other Benefits: A Review”**, *Plasma Process. Polym.*, vol. 12, pp. 608-623, (2015).
- [9] P. J. Bruggeman, F. Iza, and R. Brandenburg, **“Foundations of atmospheric pressure non-equilibrium plasmas”**, *Plasma Sources Sci. Technol.*, vol. 26 123002, (2017).



- [10] J-S. Oh, E. J. Szili, K. Ogawa, R. D. Short, M. Ito, H. Furuta, and A. Hatta, **“UV–vis spectroscopy study of plasma-activated water: Dependence of the chemical composition on plasma exposure time and treatment distance”**, *Jpn. J. Appl. Phys.*, Vol. 57 0102B9, (2018).
- [11] Y. Gorbanev, A. Privat-Maldonado, and A. Bogaerts, **“Analysis of Short-Lived Reactive Species in Plasma–Air–Water Systems: The Dos and the Do Nots”**, *Analytical Chemistry*, vol. 90(22), pp. 13151-13158, (2018).
- [12] M. M. Hefny, C. Pattyn, P. Lukes, and J. Benedikt, **“Atmospheric plasma generates oxygen atoms as oxidizing species in aqueous solutions”**, *J. Phys. D: Appl. Phys.*, vol. 49 404002, (2016).
- [13] H. Kuwahata, and I. Mikami, **“Generation of Nitric Acid and Nitrous Acid in Distilled Water Irradiated with Atmospheric-Pressure Plasma Jet”**, *e-J. Surf. Sci. Nanotech.*, vol. 12, pp. 410-413, (2014).
- [14] J. Šírová, M. Sedlářová, J. Piterková, L. Luhová, and M. Petřivalský, **“The role of nitric oxide in the germination of plant seeds and pollen”**, *Plant Science*, vol. 181, pp. 560-572, (2011).
- [15] L. Ling, J. Jiafeng, L. Jiangang, S. Minchong, H. Xin, S. Hanliang, and D. Yuanhua, **“Effects of cold plasma treatment on seed germination and seedling growth of soybean”**, *Sci. Rep.*, vol. 4 5859, (2014).
- [16] N. Puač, N. Škoro, K. Spasić, S. Živković, M. Milutinović, G. Malović, and Z. Lj. Petrović, **“Activity of catalase enzyme in Paulownia tomentosa seeds during the process of germination after treatments with low pressure plasma and plasma activated water”**, *Plasma Process Polym.*, 15:e1700082, (2018).
- [17] N. Puač, Z. Lj. Petrović, S. Živković, Z. Giba, D. Grubišić, and A.R. Đorđević, **“Low-temperature Plasma Treatment of Dry Empress-Tree Seeds”**, in *Plasma Processes and Polymers*, edited by R. d’Agostino, P. Favia, C. Oehr, and M. R. Wertheimer, ch. 15, pp. 193-203, (2005).

- [18] F. Judée, S. Simon, C. Bailly, and T. Dufour, **“Plasma-activation of tap water using DBD for agronomy applications: Identification and quantification of long lifetime chemical species and production/ consumption mechanisms”**, *Water Research*, vol. 133, pp. 47-59, (2018).
- [19] V. Štěpánová, P. Slavíček, J. Kelar, J. Prášil, M. Smékal, M. Stupavská, J. Jurmanová, and M. Černák, **“Atmospheric pressure plasma treatment of agricultural seeds of cucumber (*Cucumis sativus L.*) and pepper (*Capsicum annuum L.*) with effect on reduction of diseases and germination improvement”**, *Plasma Process Polym.*, 15:e1700076, (2018).
- [20] J. Golda, J. Held, B. Redeker, M. Konkowski, P. Beijer, A. Sobota, G. Kroesen, N. St. J. Braithwaite, S. Reuter, M. M. Turner, T. Gans, D. O’Connell, and V. Schulz-von der Gathen, **“Concepts and characteristics of the ‘COST Reference Microplasma Jet’”**, *J. Phys. D: Appl. Phys.*, vol. 49 084003, (2016).
- [21] Y. Gorbanev, J. Golda, V. Schulz-von der Gathen, and A. Bogaerts, **“Applications of the COST Plasma Jet: More than a Reference Standard”**, *Plasma*, vol. 2, pp. 316-327, (2019).
- [22] Y. Gorbanev, C. C. W. Verlaack, S. Tinck, E. Tuenter, K. Foubert, P. Cos, and A. Bogaerts, **“Combining experimental and modelling approaches to study the sources of reactive species induced in water by the COST RF plasma jet”**, *Phys. Chem. Chem. Phys.*, vol. 20, pp. 2797-2808, (2018).
- [23] J. Golda, **“Cross-correlating discharge physics, excitation mechanisms and plasma chemistry to describe the stability of an RF-excited atmospheric pressure argon plasma jet”**, PhD thesis, Ruhr-Universität Bochum, (2017).
- [24] S. Kelly, J. Golda, M. M. Turner, and V. Schulz-von der Gathen, **“Gas and heat dynamics of a micro-scaled atmospheric pressure plasma reference jet”**, *J. Phys. D: Appl. Phys.*, vol. 48 444002, (2015).
- [25] A. Khlyustova, C. Labay, Z. Machala, M-P. Ginebra, and C. Canal, **“Important parameters in plasma jets for the production of RONS in liquids for plasma medicine: A brief review”**, *Front. Chem. Sci. Eng.*, vol. 13(2), pp. 238-252, (2019).

- [26] I. C. Gerber, I. Mihaila, D. Hein, A. V. Nastuta, R. Jijie, V. Pohoata, and I. Topala, **“Time Behaviour of Helium Atmospheric Pressure Plasma Jet Electrical and Optical Parameters”**, *Appl. Sci.*, vol. 7, pp. 812-827, (2017).
- [27] [https://www.merckmillipore.com › WFS › ja\\_JP › JPY](https://www.merckmillipore.com › WFS › ja_JP › JPY)
- [28] G. M. Eisenberg, **“Colorimetric Determination of Hydrogen Peroxide”**, *Ind. Eng. Chem. Anal. Ed.*, vol. 15(5), pp. 327-328, (1943).
- [29] H. El-Maarouf-Bouteau and C. Bailly, **“Oxidative signaling in seed germination and dormancy”**, *Plant Signaling & Behavior*, 3:3, pp. 175-182, (2008).
- [30] P. Lukes, E. Dolezalova, I. Sisrova, and M. Clupek, **“Aqueous-phase chemistry and bactericidal effects from an air discharge plasma in contact with water: evidence for the formation of peroxyxynitrite through a pseudo-second-order post-discharge reaction of H<sub>2</sub>O<sub>2</sub> and HNO<sub>2</sub>”**, *Plasma Sources Sci. Technol.*, vol. 23 015019, (2014).