



CREaTE

Canterbury Research and Theses Environment

Canterbury Christ Church University's repository of research outputs

<http://create.canterbury.ac.uk>

Please cite this publication as follows:

Wang, M., Yang, C. and Mousoli, R. (2018) Controlled cyclic remote state preparation of arbitrary qubit states. *CMC: Computers, Materials & Continua*, 55 (2). pp. 321-329. ISSN 1546-2218.

Link to official URL (if available):

<https://doi.org/10.3970/cmc.2018.02064>

This version is made available in accordance with publishers' policies. All material made available by CReaTE is protected by intellectual property law, including copyright law. Any use made of the contents should comply with the relevant law.

Contact: create.library@canterbury.ac.uk



Controlled Cyclic Remote State Preparation of Arbitrary Qubit States

Mingming Wang^{1,2,*}, Chen Yang¹ and Reza Mousoli³

Abstract: Quantum secure communications could securely transmit quantum information by using quantum resource. Recently, novel applications such as bidirectional and asymmetric quantum protocols have been developed. In this paper, we propose a new method for generating entanglement which is highly useful for multiparty quantum communications such as teleportation and Remote State Preparation (RSP). As one of its applications, we propose a new type of quantum secure communications, i.e. cyclic RSP protocols. Starting from a four-party controlled cyclic RSP protocol of one-qubit states, we show that this cyclic protocol can be generalized to a multiparty controlled cyclic RSP protocol for preparation of arbitrary qubit states. We point out that previous bidirectional and asymmetric protocols can be regarded as a simpler form of our cyclic RSP protocols.

Keywords: Quantum secure communications, remote state preparation, cyclic communications, asymmetric communications, bidirectional communications, quantum control.

1 Introduction

Quantum communications and quantum computation have become hot topics in recent years since their great potential for protecting sensitive information [Bennett and Brassard (1984)] and accelerating classical computation [Shor (1997)]. Quantum entanglement is a crucial resource for quantum communications and quantum computation. For example, by using pre-shared entanglement, quantum cryptograph [Hillery (1999); Wang, Chen and Yang (2014); Terhal, DiVincenzo and Leung (2001); Qu, Chen, Zhou et al. (2010)] can be built to achieve high-level security than their classical counterparts [Shamir (1979); Meng, Rice, Wang et al. (2018); Zhou, Qiu, Li et al. (2018)].

Quantum teleportation and remote state preparation (RSP) are two typical examples of quantum communications based on entanglement. Quantum teleportation [Bennett, Brassard, Crepeau et al. (1993)] can securely transmit a quantum state from a sender to a remote receiver by virtue of pre-shared entangled resource. Similar to teleportation, remote state preparation (RSP) [Lo (2000); Pati (2000); Bennett, DiVincenzo, Shor et al.

¹Shanxi Key Laboratory of Clothing Intelligence, School of Computer Science, Xi'an Polytechnic University, Xi'an 710048, China.

² State and Local Joint Engineering Research Center for Advanced Networking & Intelligent Information Services, School of Computer Science, Xi'an Polytechnic University, Xi'an 710048, China.

³ School of Law, Criminal Justice and Computing, Canterbury Christ Church University, Canterbury, Kent, UK.

*Corresponding author: Mingming Wang. Email: blues1982@126.com.

(2001)] can complete the same work with a simpler measurement and less classical communication costs if the sender has the full information of its state. Since its first appearance, different types of RSP protocols have been developed, including oblivious RSP [Leung and Shor (2003)], high dimensional RSP [Zeng and Zhang (2002)], continuous variable RSP [Kurucz, Adam, Kis et al. (2005)], joint RSP [Xia, Song and Song (2007)], controlled RSP [Wang (2011)], etc.

In recent years, a new type of quantum communications protocols has been developed, which is known as bidirectional quantum communications. Huelga et al. [Huelga, Vaccaro and Chefles (2001); Huelga, Plenio and Vaccaro (2002)] firstly introduced the idea of bidirectional quantum teleportation where two players can send quantum states to each other simultaneously. Recently, some studies on bidirectional quantum communications have been further extended, including bidirectional controlled protocols, bidirectional protocols with quantum noise, asymmetric bidirectional protocols, cyclic teleportation protocols, etc. For example, Zha et al. [Zha, Zou, Qi et al. (2013)] proposed a bidirectional controlled teleportation protocol. Sharma et al. [Sharma, Shukla, Banerjee et al. (2015)] investigated a bidirectional RSP protocol in amplitude-damping and phase-damping noise. Li et al. [Li and Jin (2016)] proposed a bidirectional controlled teleportation protocol in noisy environment. Chen et al. [Chen, Sun, Xu et al. (2017)] studied a controlled bidirectional remote preparation of three-qubit state. Nie et al. [Nie and Sang (2017)] presented an asymmetric bidirectional controlled teleportation where two senders can send to each other different numbers of qubits simultaneously. Chen et al. [Chen, Du, Liu et al. (2017)] proposed a cyclic quantum teleportation protocol for three-qubits using six-qubit maximally entangled state as the quantum channel.

In this paper, we propose a new type of RSP protocols, namely, cyclic RSP protocols for preparing arbitrary qubits among arbitrary number of players with a quantum control. The rest of this paper is organized as follows. In Section 2, we propose a new method for generating entanglement for controlled multiparty quantum communications. Then the entanglement used in our cyclic RSP protocols is presented. In Section 3, our four-party controlled cyclic RSP protocol of one-qubit states is shown, followed by our multiparty controlled cyclic RSP protocol. In Section 4, the framework of multiparty controlled cyclic RSP protocol for arbitrary qubits is outlined. The paper is further discussed and concluded in Section 5.

2 Entanglement channels

In the following, we propose a new method for generating entanglement that could be used for controlled multiparty quantum communications, such as quantum teleportation and RSP, etc. Suppose we have two orthogonal entangled states $|\Delta_1\rangle$ and $|\Delta_2\rangle$, a new type of entanglement can be generated as follows

$$|\Lambda\rangle = \frac{1}{\sqrt{2}} [|\Delta_1\rangle|\Delta_1\rangle\cdots|\Delta_1\rangle|0\rangle + |\Delta_2\rangle|\Delta_2\rangle\cdots|\Delta_2\rangle|1\rangle] \quad (1)$$

where $|\Delta_1\rangle$ and $|\Delta_2\rangle$ could be any of two orthogonal entangled states, such as Bell states, GHZ states or W states, etc.

For example, if we select $|\Delta_1\rangle$ and $|\Delta_2\rangle$ as two Bell states, the following state can be generated

$$|\Omega(2n+1)\rangle = \frac{1}{\sqrt{2}} \left[|\Phi^+\rangle_{12} |\Phi^+\rangle_{34} \cdots |\Phi^+\rangle_{2n-1,2n} |0\rangle_{2n+1} + |\Psi^-\rangle_{12} |\Psi^-\rangle_{34} \cdots |\Psi^-\rangle_{2n-1,2n} |1\rangle_{2n+1} \right] \quad (2)$$

where $|\Phi^+\rangle = (|00\rangle + |11\rangle)/\sqrt{2}$ and $|\Psi^-\rangle = (|01\rangle - |10\rangle)/\sqrt{2}$, the subscripts denote the qubits of the state, and there are $2n+1$ qubits in the state. The above state is a generalized version of the entanglement used in Li et al. [Li and Jin (2016)].

The entanglement shown in Eq. (2) can be prepared as follows. A set of $2n+1$ qubits in $|0\rangle_1 |0\rangle_2 \cdots |0\rangle_{2n+1}$ is prepared initially. In the following, a Hadamard gate H is performed on the $(2n+1)$ -th qubit. And $2n$ CNOT gates are performed on qubits pair $(2n+1, i)$ respectively, with $i \in \{1, 2, \dots, 2n\}$, where qubit $2n+1$ is the control qubit and each qubit i is the target qubit. Here, a $(2n+1)$ -qubit GHZ state is prepared as follows

$$\frac{1}{\sqrt{2}} \left[|00 \cdots 00\rangle_{1,2,\dots,2n,2n+1} + |11 \cdots 11\rangle_{1,2,\dots,2n,2n+1} \right] \quad (3)$$

Next, an H gate is performed on qubit 1, followed by a CNOT gate on qubits pair $(1, 2)$ where 1 is the control qubit and 2 is the target qubit. Similarly, a series of H gates are performed on qubit $2i-1$, followed by CNOT gates on qubits pair $(2i-1, 2i)$ where $2i-1$ is the control qubit and $2i$ is the target qubit, with $i \in \{1, 2, \dots, n\}$. Here, one will get the state shown in Eq. (2). The process of the preparation is illustrated in Fig. 1.

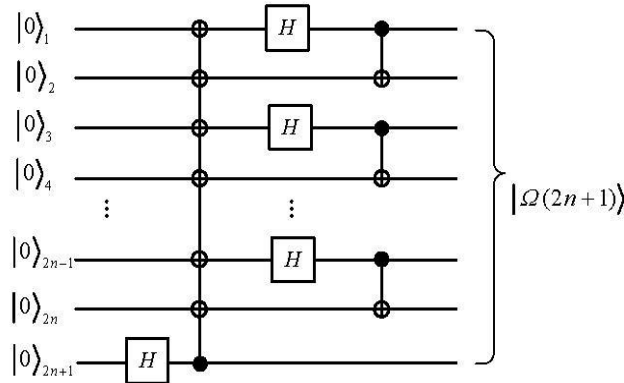

Figure 1: The quantum circuit for preparation of the entanglement resource in Eq. (2)

3 Controlled cyclic RSP of one-qubits

In the following, we will show our controlled cyclic RSP protocols of one-qubit states.

3.1 Four-party controlled cyclic RSP protocol of arbitrary one-qubits

For simplicity, a four-party cyclic RSP protocol is presented firstly. There are 3 players Alice₁, Alice₂ and Alice₃, and a controller Charlie involved in this protocol. Each of the player acts both as a sender and as a receiver, while Alice_i can transmit a qubit state to

Alice_{(i+1) mod 3} under the control of Charlie. The state prepared by Alice_i has the form

$$|\varphi_i\rangle = a_i|0\rangle + b_i e^{i\theta_i} |1\rangle \tag{4}$$

where $a_i, b_i \in \mathbf{R}$, $a_i^2 + b_i^2 = 1$, $\theta_i \in [0, 2\pi]$ with $i \in \{1, 2, 3\}$.

And the relationships among players and the controller are represented in Fig. 2, where quantum communications among 3 players forms a circle, which is the reason why it is called the cyclic protocol.

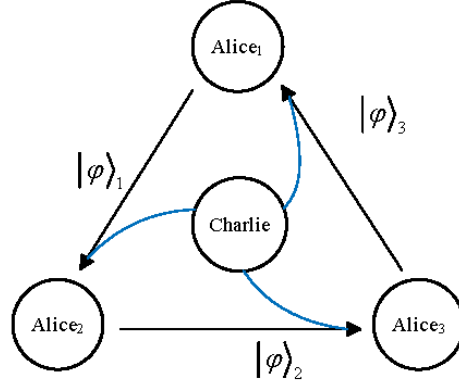

Figure 2: The relationships among three players and one controller in the four-party cyclic RSP protocol, where each player Alice_i can transmit a qubit state to her neighbor player Alice_{(i+1) mod 3} under the control of the controller Charlie. The black arrow points out the direction of the communications and the blue line represents the control information

The entanglement channel share among four participants is $|\Omega(7)\rangle$, which has the form

$$|\Omega(7)\rangle = \frac{1}{\sqrt{2}} \left[|\Phi^+\rangle_{12} |\Phi^+\rangle_{34} |\Phi^+\rangle_{56} |0\rangle_7 + |\Psi^-\rangle_{12} |\Psi^-\rangle_{34} |\Psi^-\rangle_{56} |1\rangle_7 \right] \tag{5}$$

where Alice₁ holds qubits (1, 6), Alice₂ holds (2, 3), Alice₃ holds (4, 5), and Charlie holds 7.

To complete the task, each Alice_i performs a projective measurement on her qubit 2i-1 in the basis $\{|P_0^i\rangle, |P_1^i\rangle\}$ with $i \in \{1, 2, 3\}$, where the basis is defined as

$$|P_0^i\rangle = a_i |0\rangle + b_i e^{-i\theta_i} |1\rangle, \quad |P_1^i\rangle = b_i e^{i\theta_i} |0\rangle - a_i |1\rangle \tag{6}$$

Suppose Alice₁ measures qubit 1 firstly, then the system becomes

$$|\Omega(7)\rangle = \frac{1}{\sqrt{2}} \left\{ \left[|P_0^1\rangle (a_1 |0\rangle + b_1 e^{i\theta_1} |1\rangle) + |P_1^1\rangle (b_1 e^{-i\theta_1} |0\rangle - a_1 |1\rangle) \right] |\Phi^+\rangle_{34} |\Phi^+\rangle_{56} |0\rangle_7 \right. \\ \left. + \left[|P_0^1\rangle (a_1 |1\rangle - b_1 e^{i\theta_1} |0\rangle) + |P_1^1\rangle (b_1 e^{-i\theta_1} |0\rangle + a_1 |1\rangle) \right] |\Psi^-\rangle_{34} |\Psi^-\rangle_{56} |1\rangle_7 \right\} \tag{7}$$

If the controller agrees to help the receiver Alice₂ to recover the state, he performs a single qubit measurement on his qubit 7 in the computational basis and sends the result to Alice₂. For example, if the controller gets his measurement result as $|0\rangle_7$, the quantum

system becomes

$$\left[\left| P_0^1 \right\rangle (a_1 |0\rangle + b_1 e^{i\theta_1} |1\rangle) + \left| P_1^1 \right\rangle (b_1 e^{-i\theta_1} |0\rangle - a_1 |1\rangle) \right] \left| \Phi^+ \right\rangle_{34} \left| \Phi^+ \right\rangle_{56} \quad (8)$$

As is shown in the above, if Alice₁'s measurement result is $|P_0^1\rangle$, Alice₂ will get $|\varphi_1\rangle$. After receiving Alice₁'s and Charlie's measurement results, Alice₂ recovers $|\varphi_1\rangle$ by performing a corresponding unitary operation I or $\sigma_x \sigma_z$ on her qubit. While if Alice₁'s measurement result is $|P_1^1\rangle$, the preparation protocol fails. Similarly, Alice₃ and Alice₁ can also recover related qubits if they get corresponding measurement results.

3.2 Multiparty controlled cyclic RSP protocol of arbitrary one-qubits

The controlled cyclic RSP protocol can be extended to multiparty scenario easily. A multiparty controlled cyclic RSP protocol can be described as follows. Suppose there are $n+1$ participants, i.e. players Alice₁, Alice₂, \dots and Alice _{n} , and the controller Charlie, involved in the multiparty RSP protocol. Alice _{i} can prepare a qubit state $|\varphi_i\rangle$ to her neighbor Alice _{$(i+1) \bmod n$} under the control of Charlie.

The entanglement channel share among participants is $|\Omega(2n+1)\rangle$ in Eq. (3), where Alice₁ holds qubits (1, 2n), each other Alice _{i} holds (2-2, 2i-1), i.e. Alice₂ holds (2, 3), \dots , Alice _{n} holds (2n-2, 2n-1), and Charlie holds 2n+1.

In the protocol, each Alice _{i} performs a projective measurement on her qubit 2i-1 in the basis $\left\{ \left| P_0^i \right\rangle, \left| P_1^i \right\rangle \right\}$, which is defined in Eq. (6), with $i \in \{1, 2, \dots, n\}$.

Suppose Alice₁ measures qubit 1 firstly, then the system becomes

$$\begin{aligned} & \left| \Omega(2n+1) \right\rangle \\ &= \frac{1}{\sqrt{2}} \left\{ \left[\left| P_0^1 \right\rangle (a_1 |0\rangle + b_1 e^{i\theta_1} |1\rangle) + \left| P_1^1 \right\rangle (b_1 e^{-i\theta_1} |0\rangle - a_1 |1\rangle) \right] \left| \Phi^+ \right\rangle_{34} \cdots \left| \Phi^+ \right\rangle_{2n-1, 2n} |0\rangle_{2n+1} \right. \\ & \quad \left. + \left[\left| P_0^1 \right\rangle (a_1 |1\rangle - b_1 e^{i\theta_1} |0\rangle) + \left| P_1^1 \right\rangle (b_1 e^{-i\theta_1} |0\rangle + a_1 |1\rangle) \right] \left| \Psi^- \right\rangle_{34} \cdots \left| \Psi^- \right\rangle_{2n-1, 2n} |1\rangle_{2n+1} \right\} \quad (9) \end{aligned}$$

The receiver can get the prepared state if she gets measurement results from both the sender and the controller.

4 Controlled cyclic RSP of arbitrary qubits states

Here, we consider the situation where one sender can transmit more than one-qubit information to related receiver.

Suppose Alice₁ wants to send m_1 -qubit to Alice₂ under quantum control of Charlie, the following entanglement can be shared

$$\frac{1}{\sqrt{2}} \left[\bigotimes_{k_1=1}^{m_1} \left| \Phi^+ \right\rangle_{A_1^{(k_1)}, A_2^{(k_1)}} |0\rangle_{(2m_1+1)} + \bigotimes_{k_1=1}^{m_1} \left| \Psi^- \right\rangle_{A_1^{(k_1)}, A_2^{(k_1)}} |1\rangle_{(2m_1+1)} \right] \quad (10)$$

where Alice₁ holds qubits set $A_1^{(k_1)}$, Alice₂ holds qubits set $A_2^{(k_2)}$, with $k_i \in \{1, 2, \dots, m_i\}$, and Charlie holds the control qubit labeled by $2m_1+1$.

This idea can be further extend to a more general situation where there are n players, Alice₁, Alice₂, ..., and Alice_n who form a circle, each Alice_i can send m_i -qubit to her neighbor Alice_{(i+1) mod n} under the control of Charlie. The entanglement shared should have the following form

$$\begin{aligned} & |\Omega(2\sum m_i + 1)\rangle \\ &= \frac{1}{\sqrt{2}} \left[\bigotimes_{k_1=1}^{m_1} |\Phi^+\rangle_{A_1^{(k_1)}, A_2^{(k_1)}} \bigotimes_{k_2=1}^{m_2} |\Phi^+\rangle_{A_3^{(k_2)}, A_4^{(k_2)}} \cdots \bigotimes_{k_n=1}^{m_n} |\Phi^+\rangle_{A_{2n-1}^{(k_n)}, A_{2n}^{(k_n)}} |0\rangle_{(2\sum m_i + 1)} \right. \\ & \quad \left. + \bigotimes_{k_1=1}^{m_1} |\Psi^-\rangle_{A_1^{(k_1)}, A_2^{(k_1)}} \bigotimes_{k_2=1}^{m_2} |\Psi^-\rangle_{A_3^{(k_2)}, A_4^{(k_2)}} \cdots \bigotimes_{k_n=1}^{m_n} |\Psi^-\rangle_{A_{2n-1}^{(k_n)}, A_{2n}^{(k_n)}} |1\rangle_{(2\sum m_i + 1)} \right] \end{aligned} \quad (11)$$

where Alice₁ holds qubits set $A_1^{(k_1)}$ as a sender, while she holds set $A_{2n}^{(k_n)}$ as a receiver. Alice₂ holds qubits set $A_3^{(k_2)}$ as a sender, while holds $A_2^{(k_1)}$ as a receiver. Similarly, Alice_i holds qubits set $A_{2i-1}^{(k_i)}$ as a sender for sending m_i -qubit to Alice_{i+1}, while she holds $A_{2i-2}^{(k_{i-1})}$ as a receiver for receiving (m_i-1) -qubit from Alice_{i-1}, etc. Charlie holds the control qubit labeled by $2\sum m_i + 1$.

Suppose the controller performs a measurement on his qubit in the computational basis, the entanglement shared among two neighbors Alice_i and Alice_{i+1} will be either $\bigotimes_{k_i=1}^{m_i} |\Phi^+\rangle_{A_{2i-1}^{(k_i)}, A_{2i}^{(k_i)}}$ or $\bigotimes_{k_i=1}^{m_i} |\Psi^-\rangle_{A_{2i-1}^{(k_i)}, A_{2i}^{(k_i)}}$, which are m_i pairs of Bell states. By using these resources, a m_i -qubit can be prepared from Alice_i to Alice_{i+1}. See Bennett et al. [Bennett, DiVincenzo, Shor et al. (2001)] for more details.

5 Discussion and conclusion

It should be noted that previous bidirectional and asymmetric RSP protocols can be implemented as a simpler form of our cyclic RSP protocols. For implementation of a bidirectional RSP protocol, just let two players, Alice₁ and Alice₂ involved in our cyclic RSP protocols, where Alice₁ and Alice₂ can send to each other quantum states. For an asymmetric RSP protocol, just let two players, Alice₁ and Alice₂ involved, where Alice₁ and Alice₂ sending different number of qubits to each other. For example, if one lets $m_1=1$ and $m_2=2$ (see Section 4), an asymmetric RSP protocol is implemented in such a way that Alice₁ can send one-qubit to Alice₂ while Alice₂ can send two-qubit to Alice₁.

Compared with previous studies, similar functions can be implemented in our protocols. If there are two senders and one controller, our protocol performs a similar function as bidirectional controlled teleportation [Zha, Zou and Qi (2013); Li and Jin (2016); Nie and Sang (2017)] or bidirectional remote state preparation [Sharma, Shukla, Banerjee et al. (2015); Chen, Du, Liu et al. (2017)].

As we discussed above, if one lets Alice₁ send one-qubit and Alice₂ send two-qubit, the protocol implements a similar function as the bidirectional controlled remote state

preparation in Nie et al. [Nie and Sang (2017)]. Besides, it is clear that the entanglement in Eq. (2) can also be used for bidirectional ($n=2$) or cyclic ($n>2$) quantum teleportation. And previous cyclic quantum teleportation such as Chen et al. [Chen, Du, Liu et al. (2017)] can also be implemented using this kind of entanglement.

In summary, we have proposed a new method to form entanglement in Eq. (1) by using a set of orthogonal entangled states. This method is very useful for multiparty quantum communications or quantum networks [Luo (2018); Qu, Keeney, Robitzsch et al. (2016)]. As one of its applications, we studied a type of cyclic RSP protocols with a quantum control based on one of its simple example shown in Eq. (2). Our protocols can be used to send quantum information among multiple players either in a symmetric or an asymmetric manner. In its simplest case where two players are involved, it becomes a bidirectional protocol. In the future, it is interesting to study other applications and consider other situations such as quantum noise.

Acknowledgement: The authors wish to express their appreciation to the reviewers for their helpful suggestions which greatly improved the presentation of this paper. This project was supported by NSFC (Grant No. 61601358).

References

- Bennett, C. H.; Brassard, G.** (1984): Quantum cryptography: Public key distribution and coin tossing. *Proceedings of IEEE International Conference on Computers Systems and Signal Processing*, pp. 175-179.
- Bennett, C. H.; Brassard, G.; Crepeau, C.; Jozsa, R.; Peres, A. et al.** (1993): Teleporting an unknown quantum state via dual classical and einstein-podolsky-rosen channels. *Physical Review Letters*, vol. 70, no. 13, pp. 1895-1899.
- Bennett, C. H.; DiVincenzo, D. P.; Shor, P. W.; Smolin, J. A.; Terhal, B. M. et al.** (2001): Remote state preparation. *Physical Review Letters*, vol. 87, no. 7.
- Chen, X. B.; Sun, Y. R.; Xu, G.; Jia, H. Y.; Qu, Z. et al.** (2017): Controlled bidirectional remote preparation of three-qubit state. *Quantum Information Processing*, vol. 16, no. 10, pp. 244.
- Chen, Y. X.; Du, J.; Liu, S. Y.; Wang, X. H.** (2017): Cyclic quantum teleportation. *Quantum Information Processing*, vol. 16, no. 8, pp. 201.
- Hillery, M.; Bužek, V.; Berthiaume, A.** (1999): Quantum secret sharing. *Physical Review A*, vol. 59, no. 3, pp. 1829.
- Huelga, S. F.; Plenio, M. B.; Vaccaro, J. A.** (2002): Remote control of restricted sets of operations: Teleportation of angles. *Physical Review A*, vol. 65, no. 4.
- Huelga, S. F.; Vaccaro, J. A.; Chefles, A.** (2001): Quantum remote control: Teleportation of unitary operations. *Physical Review A*, vol. 63, no. 4.
- Kurucz, Z.; Adam, P.; Kis, Z.; Janszky, J.** (2005): Continuous variable remote state preparation. *Physical Review A*, vol. 72, no. 5.
- Leung, D. W.; Shor, P. W.** (2003): Oblivious remote state preparation. *Physical Review Letters*, vol. 90, no. 12.

Li, Y. H.; Jin, X. M. (2016): Bidirectional controlled teleportation by using nine-qubit entangled state in noisy environments. *Quantum Information Processing*, vol. 15, no. 2, pp. 929-945.

Lo, H. K. (2000): Classical-communication cost in distributed quantum-information processing: A generalization of quantum-communication complexity. *Physical Review A*, vol. 62, no. 1.

Luo, M. X. (2018): Computationally efficient nonlinear bell inequalities for quantum networks. *Physical Review Letters*, vol. 120, no. 14.

Meng, R.; Rice, S. G.; Wang, J.; Sun, X. (2018): A fusion steganographic algorithm based on Faster R-CNN. *Computers, Materials & Continua*, vol. 1, no. 55, pp. 1-16.

Nie, Y. Y.; Sang, M. H. (2017): Asymmetric bidirectional controlled teleportation via seven-photon entangled state. *International Journal of Theoretical Physics*, vol. 56, no. 11, pp. 3452-3454.

Pati, A. K. (2000): Minimum classical bit for remote preparation and measurement of a qubit. *Physical Review A*, vol. 63, no. 1, pp. 14302-14304.

Qu, Z. G.; Keeney, J.; Robitzsch, S.; Zaman, F.; Wang, X. J. (2016): Multilevel pattern mining architecture for automatic network monitoring in heterogeneous wireless communication networks. *China Communications*, vol. 13, no. 7, pp. 108-116.

Qu, Z. G.; Chen, X. B.; Zhou, X. J.; Niu, X. X.; Yang, Y. X. (2010): Novel quantum steganography with large payload. *Optics Communications*, vol. 283, no. 23, pp. 4782-4786.

Shamir, A. (1979): How to share a secret. *Communications of the ACM*, vol. 22, no. 11, pp. 612-613.

Sharma, V.; Shukla, C.; Banerjee, S.; Pathak, A. (2015): Controlled bidirectional remote state preparation in noisy environment: A generalized view. *Quantum Information Processing*, vol. 14, no. 9, pp. 3441-3464.

Shor, P. W. (1997): Polynomial-time algorithms for prime factorization and discrete logarithms on a quantum computer. *SIAM Journal on Computing*, vol. 26, no. 5, pp. 1484-1509.

Terhal, B. M.; DiVincenzo, D. P.; Leung, D. W. (2001): Hiding bits in bell states. *Physical Review Letters*, vol. 86, no. 25, pp. 5807.

Wang, M. M.; Chen, X. B.; Yang, Y. X. (2014): Quantum secret sharing for general access structures based on multiparticle entanglements. *Quantum Information Processing*, vol. 13, no. 2, pp. 429-443.

Wang, Z. Y. (2011): Controlled remote preparation of a two-qubit state via an asymmetric quantum channel. *Communications in Theoretical Physics*, vol. 55, no. 2, pp. 244.

Xia, Y.; Song, J.; Song, H. S. (2007): Multiparty remote state preparation. *Journal of Physics B: Atomic, Molecular and Optical Physics*, vol. 40, no. 18, pp. 3719-3724.

Zeng, B.; Zhang, P. (2002): Remote-state preparation in higher dimension and the parallelizable manifold s^{n-1} . *Physical Review A*, vol. 65, no. 2.

Zha, X. W.; Zou, Z. C.; Qi, J. X.; Song, H. Y. (2013): Bidirectional quantum controlled teleportation via five-qubit cluster state. *International Journal of Theoretical Physics*, vol. 52, no. 6, pp. 1740-1744.

Zhou, Q.; Qiu, Y.; Li, L.; Lu, J.; Yuan, W. et al. (2018): Steganography using reversible texture synthesis based on seeded region growing and LSB. *Computers, Materials & Continua*, vol. 1, no. 55, pp. 151-163.