



City Research Online

City, University of London Institutional Repository

Citation: Gong, W., Wei, Y., Li, Y., Wang, Z., Zhang, T., Chang, J., Grattan, K. T. V. ORCID: 0000-0003-2250-3832 and Liu, T. (2019). Study of quasi-distributed optical fiber methane sensors based on laser absorption spectrometry. Proceedings of SPIE - The International Society for Optical Engineering, 11340, p. 1134020. doi: 10.1117/12.2548181

This is the accepted version of the paper.

This version of the publication may differ from the final published version.

Permanent repository link: <https://openaccess.city.ac.uk/id/eprint/23870/>

Link to published version: <http://dx.doi.org/10.1117/12.2548181>

Copyright and reuse: City Research Online aims to make research outputs of City, University of London available to a wider audience. Copyright and Moral Rights remain with the author(s) and/or copyright holders. URLs from City Research Online may be freely distributed and linked to.

City Research Online:

<http://openaccess.city.ac.uk/>

publications@city.ac.uk

Study of Quasi-Distributed Optical Fiber Methane Sensors based on Laser Absorption Spectrometry

Weihua Gong^a, Yubin Wei^a, Yanfang Li^a, Zhaowei Wang^a, Tingting Zhang^a,
Jun Chang^b, Kenneth T. V. Grattan^{a,c}, Tongyu Liu^{*a}

^aLaser Institute, Qilu University of Technology (Shandong Academy of Sciences), Jinan250100, Shandong;

^bSchool of Information Science and Engineering, Shandong University, Qingdao266200, Shandong

^cSchool of Mathematics, Computer Science & Engineering, City, University of London, London, EC1V 0HB, United Kingdom

ABSTRACT

The coal industry plays an important role in the economic development of China. With the increase of coal mining year by year, coal mine accidents caused by gas explosion also occur frequently, which poses a serious threat to the life safety of absenteeism and national property safety. Therefore, high-precision methane fiber sensor is of great significance to ensure coal mine safety. This paper mainly introduces two kinds of quasi-distributed gas optical fiber sensing systems based on laser absorption spectroscopy. The gas fiber optic sensor based on absorption spectrum has high measurement accuracy, fast response and long service life. One is quasi-distributed optical fiber sensing system based on spatial division multiplexing (SDM) technology and the other is quasi-distributed optical fiber sensing system based on optical time domain reflection and time division multiplexing(TDM) technology.

Keywords: Quasi-distributed; Methane detection; SDM; Optical time domain reflection; TDM

1. INTRODUCTION

Coal industry is an important pillar of China's industrial development. Safety accidents happen frequently in the process of coal mining, among which gas explosion is one of the main accidents threatening the safety of coal mines. Gas explosion has the characteristics of strong destructiveness, heavy casualties and large property loss, so gas monitoring is an effective measure to prevent gas explosion accidents. At present, the commonly used gas detection methods include carrier catalysis gas detection, thermal conductivity detection, gas-sensitive semiconductor, optical and other methods[1-2]. In recent years, with the development of semiconductor laser technology, optical fiber sensor based on laser absorption spectrum technology develops rapidly[3]. Optical fiber sensor is widely used in the field of gas monitoring because of its high measurement accuracy, fast response speed, large measurement range, strong anti-interference ability, anti-explosion and anti-combustion and other advantages. In order to better monitor the distribution of methane gas in coal mines, two gas multipoint monitoring systems are studied, one is based on SDM technology, the other is based on TDM technology. Because these two forms of quasi-distributed optical fiber methane sensing systems are all based on infrared absorption spectrum technology and a set of light source modules to realize the monitoring of multi-point space methane gas, this kind of sensing system has high detection accuracy, high sensitivity, fast response, low maintenance cost, and can realize real-time gas monitoring.

*E-mail:tongyu.liu@vip.iss-ms.com

2. PRINCIPLE OF SPECTRAL ABSORPTION DETECTION AND SELECTION OF METHANE ABSORPTION LINE

Under the condition of unsaturated absorption, the relationship between the transmitted light intensity $I_t(\nu)$ and the incident light intensity $I_0(\nu)$ at the frequency $\nu [cm^{-1}]$ satisfies Lamber-Beer law[4]:

$$I_t(\nu) = I_0(\nu) \exp[-\alpha(\nu)CL] \quad (1)$$

Where $\alpha(\nu)$ is the absorption coefficient at the frequency $\nu [cm^{-1}]$, C is the volume concentration of the target gas, L is the effective absorption path. Through formula (1), the concentration formula of target gas can be expressed as:

$$C = -\frac{1}{\alpha(\nu)L} \ln \frac{I_t(\nu)}{I_0(\nu)} \quad (2)$$

Since the absorption coefficient is a function of temperature and pressure, it can be considered that the absorption coefficient is constant and the peak height of absorption spectrum is proportional to the concentration of target gas when the detection environment is stable[5]. Therefore the concentration of the target gas can be demodulated by detecting the ratio relationship between the emitted light intensity and the incident light intensity.

According to the HITRAN database[6], we know that methane gas molecules have fundamental frequency absorption in the mid-infrared, combined frequency absorption and pan-frequency absorption in the near-infrared, and the absorption intensity in the mid-infrared is greater than that in the near-infrared. Considering the small size and cheap price of the near-infrared laser, we chosed the absorption line of methane near 1.65 microns which has a strong absorption. The absorption spectrum line of methane was selected to be around 1653.7nm, where the absorption spectrum line has a large intensity and little interference. There are three absorption lines near 1653.7nm, 1653.72224nm, 1653.72552nm and 1653.7284nm respectively. The three absorption peaks are almost completely superimposed due to the spectral line broadening, so the three absorption lines are usually treated as one absorption line. The sum absorbed by three absorption lines is the total absorption for this point.

3. A QUASI-DISTRIBUTED METHANE FIBER SENSING SYSTEM BASED ON SDM TECHNOLOGY

3.1 Spatial division multiplexing (SDM) technology

SDM technology realizes multi-point monitoring of gas through a light source module and a plurality of sensing modules. Each sensor and the respective input and output optical fiber connections constitute a sensing channel[7]. The laser outputted by DFB laser is transmitted by fiber splitter through multiple fiber optic cables. There are dozens or hundreds of optical fibers in one optical cable, and the sensor unit branch is connected through the optical cable connection box. The quasi-distributed methane sensor based on air division multiplexing technology reduces the number of light sources, reduces the cost of the system, and has the advantage of crosstalk free.

3.2 System design

The structure of quasi-distributed methane fiber optic sensing system based on SDM technology is shown in figure 1. The laser used in this system is a DFB laser with a central wavelength of 1653.7 nm. The output characteristics of the laser are controlled by operating temperature and driving current, and the modulation mode of the laser was adopted current modulation. When the system is in working state, the temperature control circuit keeps the laser's operating temperature stable and the driving current of the driving circuit changes the laser's output light intensity and output wavelength. Under the control of temperature control circuit and drive circuit, the wavelength range of the laser output covers the absorption spectrum line of 1653.722nm.

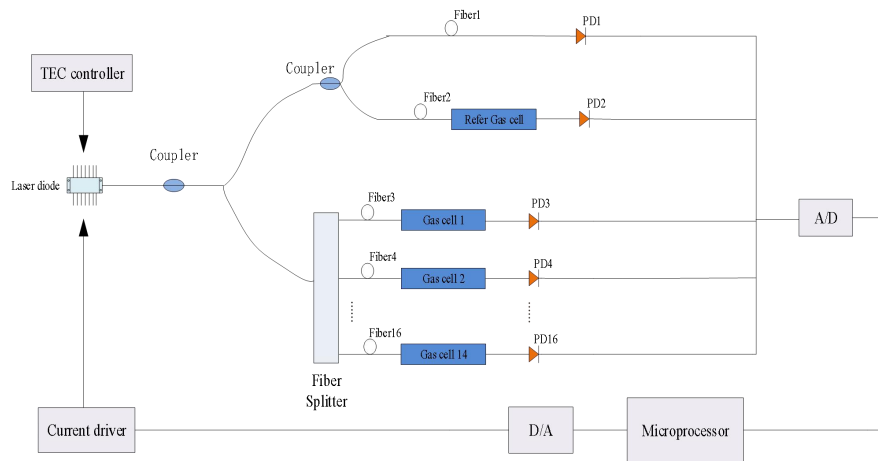

Figure 1. The structure of quasi-distributed methane fiber optic sensing system based on SDM technology.

The laser outputted from DFB laser was split into three beams by fiber coupler. One of the laser beams was directly irradiated on the photodetector as a power reference signal without any absorption. One of the laser beams passed through a reference chamber filled with a high concentration of standard methane gas and then irradiated on a photodetector. The signal was used as a reference signal to find the wavelength at the absorption peak. The operating temperature of the laser was adjusted by temperature controller in real time so that the absorption peak of the reference signal was in the center of the data sequence and the scanning range of the laser was kept unchanged. The third laser beam was split into multiple beams by a fiber splitter and each beam was transmitted to its respective sensing probe. The laser output from the sensing probe was irradiated onto the corresponding photodetector for detection. The sensing probes were placed in different positions depending on the measurement requirements.

After A/D conversion, the current signal output by the photoelectric detector is sent to the microprocessor. According to the pre-selected algorithm, data processing is carried out to obtain the concentration signal of each measurement point, which is stored and judged by alarm.

3.3 System design

The absorption spectrum of methane gas can be obtained by normalization of detection signal and power reference signal. When the detection environment is stable, the peak height of absorption spectrum is proportional to the gas concentration. Figure 2 shows the absorption spectrum of methane gas at different concentrations.

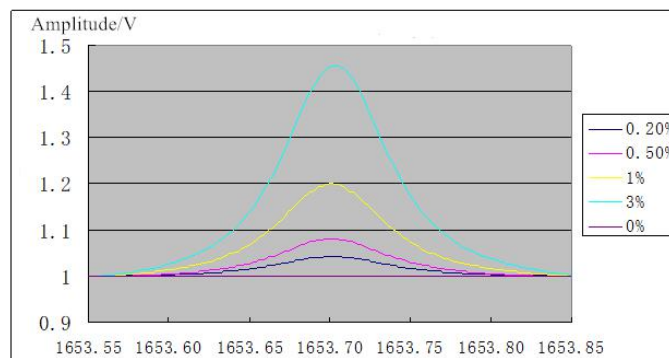

Figure 2. The absorption spectrum of methane gas at different concentrations.

After obtaining the relationship between the concentration of methane gas and the peak height of the absorption spectrum, the calibration experiments were carried out. The calibration results in the range of 0-100% are shown in Figure 3. The experimental results showed that the sensitivity of the gas sensor can reach 0.01%, the error is within $\pm 0.05\%$, and the long-term reliability is consistent with the system requirements.

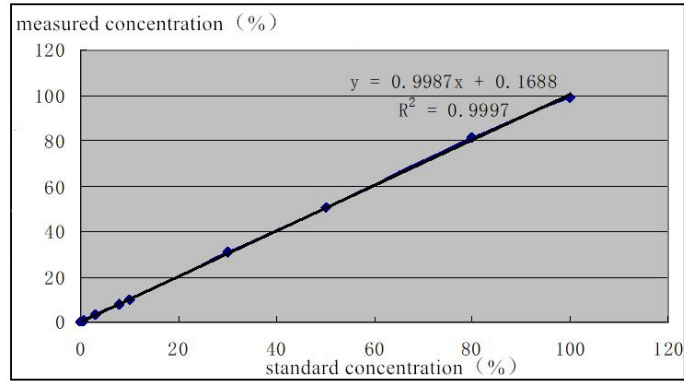

Figure 3. The calibration results in the range of 0-100%

4. A QUASI-DISTRIBUTED METHANE FIBER SENSING SYSTEM BASED ON TDM TECHNOLOGY

4.1 Spatial division multiplexing (SDM) technology

The principle of optical time domain reflection is that the pulse light emitted by the light source generates backscattering or reflection during transmission when encountering joints, breakpoints, depressions and fiber ends. Some of the scattered light and reflected light are transmitted back to the transmitting end and demodulated to obtain the required information.

Time division multiplexing (TDM) technology uses time signals as the segmentation parameters to locate multiple sensing units connected in series at different positions on a single fiber in real time. When the pulse width of the light pulse emitted by the light source is smaller than the transmission time between adjacent sensing units, since each sensing unit has a different distance from the light source, the detector will receive different light pulses after the light source pulse is injected from the input end. And one light pulse corresponds to the signal of one sensing unit.

4.2 System design

A quasi-distributed methane fiber sensing system based on TDM technology combined optical time domain reflection and TDM technology to realize multi-point gas concentration localization measurement on a single fiber. The system structure diagram is shown in Figure 4.

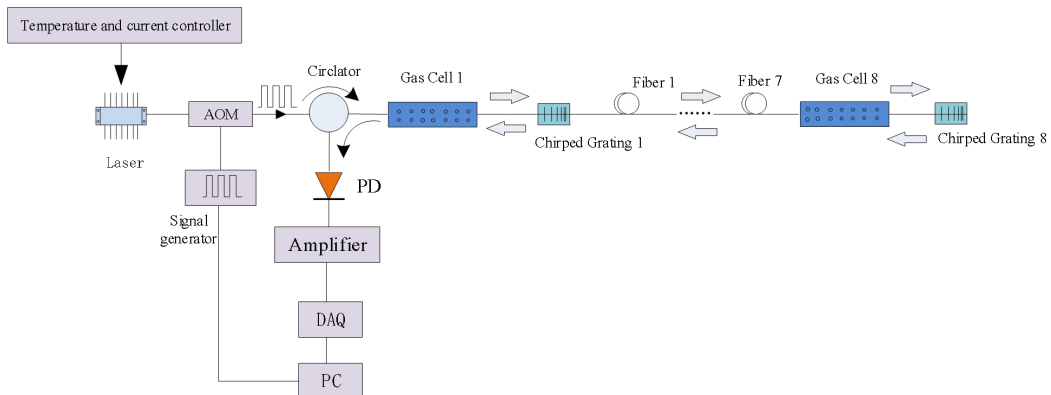

Figure 4. The structure diagram of the quasi-distributed methane fiber sensing system based on TDM technology

The laser used in this system is also a tunable laser with a center wavelength of 1653.7 nm. In order to make the laser output optical power negligible within a certain range, the laser wavelength modulation method was adopted temperature

modulation. The driving current of the laser controlled by the laser diode controller was kept constant at 50 mA, and the output wavelength was changed by changing the operating temperature of the laser. We selected 19 wavelength points around the methane absorption peak of 1653.722nm and fitted the absorption spectrum of the absorption signals at 19 wavelength points. The gas concentration value would be obtained by the peak height of absorption spectrum.

The signal generator emitted a pulse signal with a frequency of 10 kHz and a width of 40 ns, which was simultaneously transmitted to the acousto-optic modulator and data acquisition program. After receiving the pulse signal of the signal generator, the acousto-optic modulator modulated the continuous laser into pulsed light and then outputted the pulsed light by the circulator to the optical fiber of the measurement path. After receiving the pulse signal of the signal generator, the data acquisition program would control the data acquisition card to collect data.

The sensing unit of the system consists of a sensing chamber and a chirped fiber grating. The reflectance of the eight gratings is 5%, 10%, 20%, 5%, 20%, 10%, 5%, and 30%, respectively. The sensing units are separated by a length of fiber and the fiber acts as a delay. The optical signal reflected by the chirped fiber grating outputs to the photodetector through one end of the circulator. The signal output by the photodetector would be collected by the acquisition card after amplified by the amplifier.

4.3 Experimental analysis

When the pulsed light is transmitted on the fiber of the measurement route, the system will collect eight reflected signals, corresponding to eight sensing units. Figure 5 shows the eight reflected signals collected.

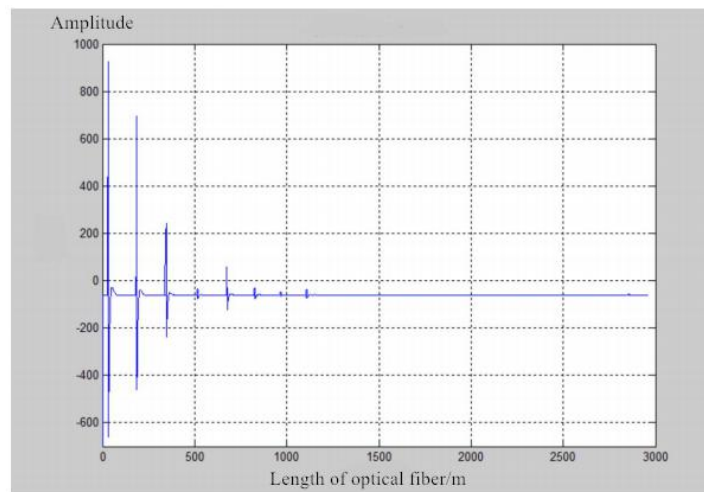

Figure 5. The eight reflected signals collected.

In order to prove the reliability of the system to detect methane gas, we tested it with a standard gas of known concentration. We filled a sensing chamber of the system with a known concentration of standard gas at a concentration of 0.505%, 1% and 2%. We flushed the residual methane gas from the chamber with nitrogen before each charge of methane gas. Table 1 shows the experimental results.

Table 1. Standard concentration and measured concentration result analysis table

| | | | |
|---------------------------|--------|--------|--------|
| Standard concentration(%) | 0.505 | 1 | 2 |
| Measured concentration(%) | 0.5056 | 0.9934 | 2.0157 |
| Relative error(%) | 0.1188 | 0.66 | 0.785 |

As can be seen from table 1, the error between the measured methane concentration and the standard concentration is within 1%, so the system can measure methane reliably. It is also proved by experiments that the dynamic characteristics of the system are better and the response speed is faster, which can monitor the methane gas in real time for a long time.

5. CONCLUSION

Two quasi-distributed optical fiber methane sensing systems discussed in this paper have realized multipoint measurement of methane gas. Compared with the traditional gas sensing module, they greatly save the cost of monitoring. The system based on SDM technology can simultaneously detect methane gas at 14 different locations, with stable performance, easy integration and meeting industrial requirements. Compared with the system based on SDM technology, the TDM system reduced the number of optical fibers and photodetectors. Although the system can simultaneously detect multi-point methane concentrations, it is still in the laboratory stage and needs further integration and performance improvement.

ACKNOWLEDGMENTS

This work was supported by the Major S&T Innovation project of Shandong Province (2018CXGC0607), Shandong provincial natural science foundation--cultivation fund (ZR20180708016)

REFERENCES

- [1] Xiao Liu, Sitian Cheng, Hong Liu, Sha Hu, Daqiang Zhang and Huansheng Ning, "A Survey on Gas Sensing Technology," *Sensors*, vol.12, 9635-9665(2012).
- [2] X. Q. Pan, Q. C. Liu, "Gas Sensor and its Development," *Journal of East China Institute of Technology*, 27(1), 89-93(2004).
- [3] T.Y. Wang, L. Zhang and W. Jin, "Minimum detection limit for methane with single laser remote sensing," *Chinese J. Laser*33(3), 405-407(2006).
- [4] H. Abitan, H. Bohr, P. Buchhave, "Correction to the Beer-Lambert-Bouguer Law for Optical Absorption," *Applied Optics*, 47(29): 5354-5357(2008).
- [5] J. Shemshad, S. M. Aminossadati, M. S. Kizil, "The effect of temperature, pressure and path-length in spectroscopic detection of methane in near infrared spectrum," *Australian Mining Technology Conference. CRCMining*, 57-64(2010).
- [6] L. S. Rothman, I. E. Gordon, A. Barbe, "The HITRAN 2008 molecular spectroscopic database," *Journal of Quantitative Spectroscopy and Radiative Transfer*, 110(9): 533-572(2009).
- [7] M. R. Zhou, Z. B. Li, Z. J. Zong, "Research on Distributed Optical Fiber Sensing Gas System," *China Safety Science Journal*, 17(8), 167-170(2007).