



Citation for published version:

Yuan, C, Pan, M & Plummer, A 2020, 'A Review of Switched Inertance Hydraulic Converter Technology', *Journal of Dynamic Systems, Measurement and Control: Transactions of the ASME*. <https://doi.org/10.1115/1.4046103>

DOI:

[10.1115/1.4046103](https://doi.org/10.1115/1.4046103)

Publication date:

2020

Document Version

Peer reviewed version

[Link to publication](#)

Publisher Rights

CC BY

(C) ASME, 2019. This is the authors' accepted manuscript of an article published in final form as Yuan, C, Pan, M & Plummer, A 2020, 'A Review of Switched Inertance Hydraulic Converter Technology', *Journal of Dynamic Systems, Measurement and Control: Transactions of the ASME* and available online via: <https://doi.org/10.1115/1.4046103>

University of Bath

General rights

Copyright and moral rights for the publications made accessible in the public portal are retained by the authors and/or other copyright owners and it is a condition of accessing publications that users recognise and abide by the legal requirements associated with these rights.

Take down policy

If you believe that this document breaches copyright please contact us providing details, and we will remove access to the work immediately and investigate your claim.

A REVIEW OF SWITCHED INERTANCE HYDRAULIC CONVERTER TECHNOLOGY

Chenggang Yuan

Min Pan*

Andrew Plummer

Centre for Power Transmission and
Motion Control
Department of Mechanical Engineering
University of Bath
Bath, United Kingdom, BA2 7AY
*Email: m.pan@bath.ac.uk

ABSTRACT

Digital hydraulics is a new technology providing an alternative to conventional proportional or servovalve-controlled systems in the area of fluid power. Digital hydraulic applications, such as digital pumps, digital valves and actuators, switched inertance hydraulic converters (SIHCs) and digital hydraulic power management systems, promise high-energy efficiency and less contamination sensitivity. Research on digital hydraulics is driven by the need for highly energy efficient hydraulic machines but is relatively immature compared to other energy-saving technologies. This review introduces the development of SIHCs particularly focusing on the work being undertaken in the last 15 years and evaluates the device configurations, performance and control strategies that are found in current SIHC research. Various designs for high-speed switching valves are presented, and their advantages and limitations are compared and discussed. Current limitations of SIHCs are discussed and suggestions for the future development of SIHCs are made. This review is an extended version of a paper presented at the BATH/ASME 2018 Symposium on Fluid Power and Motion Control [1].

1. INTRODUCTION

Digital hydraulic systems, such as digital pumps, valves and actuators, switched inertance hydraulic converters (SIHCs) and digital hydraulic power management systems, promise high energy efficiency and control flexibility. Unlike conventional hydraulic servo systems, which are widely used for precise control in hydraulics, digital hydraulic systems have the potential to be more cost-efficient, robust and less sensitive to contamination.

The SIHC concept is a sub-domain of digital hydraulics. An SIHC normally consists of high-speed switching valves, inertance tubes or mechanical inertial elements (motors, flywheels, oscillating pistons [2, 3] or load inertia), and accumulators. In an analogous approach to the electrical buck converter in Fig. 1 (a), a schematic of a three-port hydraulic SIHC is shown in Fig. 1 (b). It makes use of the inherent reactive behaviour of hydraulic components including a high-speed switching valve (switch function), a small diameter tube (inductive effect) and an accumulator (capacitive effect) in the SIHC acting as a switch, an inductor and a capacitor in the electrical circuit. When the high-speed switching valve connects to the supply pump, the high-velocity fluid passes from the pump to the load; when the valve switches from the pump to reservoir, the momentum of the fluid in the inertance tube draws the continuous flow from

the reservoir to the delivery port despite the adverse pressure gradient. As long as the switching time of the valve is short, the reduction in delivery flow will be very small, and the average delivery flow could be significantly higher than the supply flow, so this SIHC configuration is also called a flow booster. SIHCs have the potential to operate close to 100% efficiency, if friction, valve switching losses and leakage can be kept small [4], compared with conventional valve-controlled hydraulic systems which can have substantial losses; for example an average efficiency of about 30% is quoted in [5].



Fig. 1: Electrical buck converter and a three-port SIHC

The earliest design of using fluid inertia is Montgolfier’s hydraulic ram for raising water in 1796 [6] and the pioneer work related to addressing the use of fluid inertia was done by Constantinesco *et al* in which the pistons was actuated by periodic liquid impulses to generate the rotation of the motor in 1916 [7]. The concept of harnessing fluid inertia for power transmission by using alternating flows has also been discussed in [8]. The concept of SIHCs was relaunched by Brown *et al* in 1987 and the team proposed and investigated a series of SIHC configurations including a step-down transformer (flow booster), step-up transformer (pressure booster), switching gyrator and four-port SIHC analogously to electrical switched inductance transformers [9]. They concluded that the hydraulic transformers have clear potential to improve hydraulic system bandwidth and energy efficiency based on comprehensive theoretical studies. They designed a high-speed rotary switching valve [9], which inspired the development of various rotary valves used in today’s research [4], to carry out the experimental validation. The rotary valve was used in a four-port SIHC prototype for static and dynamic studies [10]. However, the experimental results were not as predicted because cavitation and large pressure pulsations occurred. Brown *et al* suggested that more fundamental research should be focused on the fluid dynamics of SIHCs, the reasons for cavitation and nonlinearity, and the design and optimization of high-speed valves [10]. The team later designed and modelled an electrohydraulic flapper-nozzle valve [11]. The valve can be driven by a Pulse Width Modulation (PWM) signal with a frequency up to 500 Hz. The experimental dynamic response of the valve at 100 Hz agrees well with the analytical results, but the static characteristics were not discussed. The success of Brown *et al*’s work inspired subsequent research on the design of high-speed switching valves and the investigation of SIHC characteristics.

In this review, the first section reviews different configurations of SIHCs and presents state-of-the-art modelling techniques. The second section reviews the designs of various high-speed switching valves and evaluates the valves in terms of pressure-flow characteristics, response time and manufacturing cost. It concludes with some suggestions for the future developments of high-speed switching valves and SIHCs.

2. SIHC SYSTEM RESEARCH

Figure 2 shows recent publications related to SIHCs cited in this review, which are categorised as SIHC characteristics, SIHC improvement and high-speed switching valve design. This research has emanated from Linz (Austria), the USA, Canada, the Nordic

countries, Brazil, and Bath (UK). Figure 3 shows the research can be categorised into three main aspects: the system, the components and the current problems (noise and cavitation).

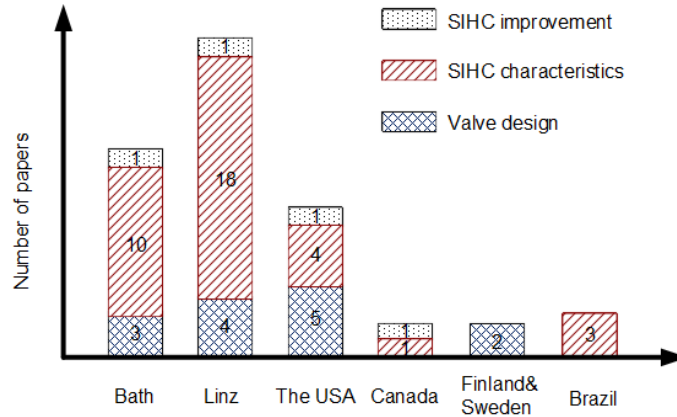

Fig. 2: Recent publications cited in this review (2003-2018)

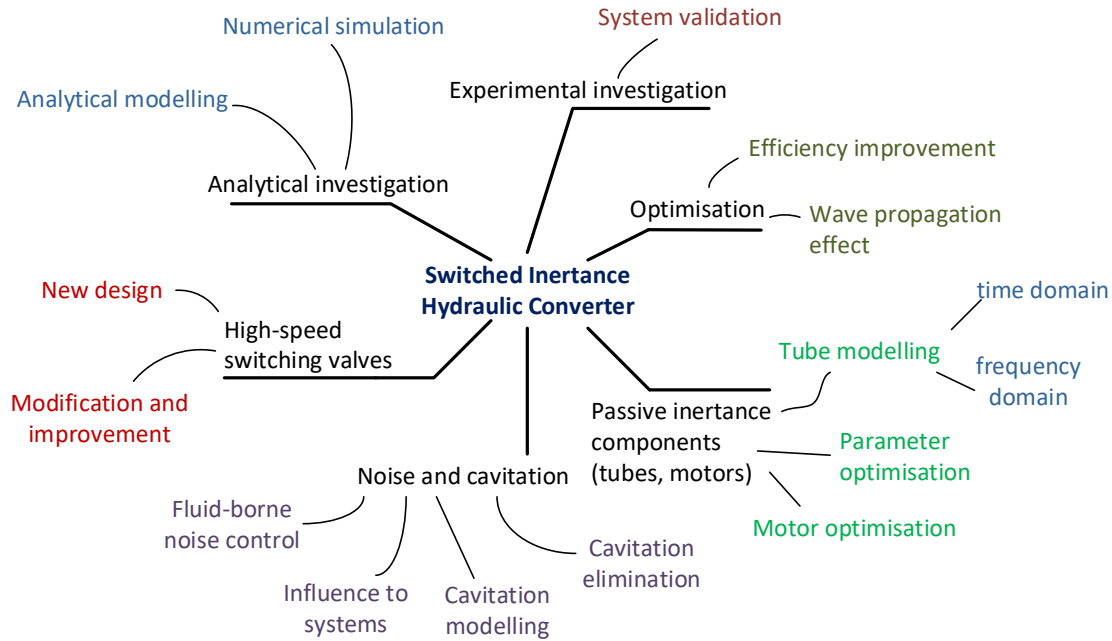

Fig. 3: Research areas of switched inductance hydraulic converters

Scheidl et al. designed a resonator system and developed an analytical model for the system in 1995 at Linz [12]. The team found that the resonator with a length of 0.65m requires a high-speed valve with a switching frequency of 1 kHz, and designed a rotary valve in order to fulfil the requirements. The study involves theoretical analysis and modelling but not with experimental validation due to the limited bandwidth of the switching valve in practice at that time. Researchers realized that the performance of high-speed switching valves was a limiting factor in the development of SIHCs. To tackle this challenge, Winkler and Scheidl designed a high-speed solenoid-controlled spool valve in 2006 with a fast response speed of 1ms. The valve has a low resistance with a nominal flow rate of 45 L/min at a pressure drop of 5 bar. Ease of manufacture and cost efficiency are the advantages of the valve [13]. Winkler also designed an

alternative poppet valve which can deliver a maximum flow rate of about 90 L/min with a similar pressure drop of 5 bar [14]. However, the main stage response speed is about 2 ms, which limits the switching frequency of SIHCs. The team also investigated the hydraulic buck converter (HBC) [15]. A typical HBC consists of a two-port high-speed on-off valve and a check valve is shown in Fig. 4, where the check valve is arranged in the return line to prevent back flow. In this configuration, the check valve characteristics affects HBC performance and may cause cavitation due to the high-pressure drop across the valve.

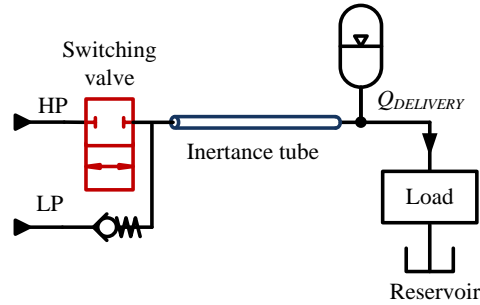

Fig. 4: Configuration of a typical HBC [15]

To eliminate cavitation, a nonlinear oscillator was designed to boost the tank line pressure [16]. The oscillator was driven by an ideally assumed rectangular pressure wave. Simulated results showed that the oscillator can increase the tank pressure to 15 bar. However, it results in more complex system dynamics and the oscillator needs to be further investigated combined with the real HBC system. In 2008, Kogler and Scheidl reviewed two basic concepts of hydraulic switching converters and concluded that the performance of hydraulic converters is affected by the valve dynamics, parasitic effects, wave propagation along the pipe, system nonlinearities and pressure pulsations [17]. These effects should be well understood for the design and optimization of SIHCs. An extended HBC including two switching valves and two check valves was developed to provide bi-direction ability as shown in Fig. 5. The HBC was designed in a more compact way by arranging the pipes in a loop in 2010 so that the HBC could be easily integrated into a machine, vehicle or robot [18]. Load pressure and efficiency of the compact HBC were investigated for the ‘forward mode’ and the ‘reverse mode’. The results show 34% energy was saved compared with conventional resistance control. The performance of HBC in the pressure control mode was also analysed by driving a cylinder at load. The result shows that energy consumption was reduced by at least 59% [19].

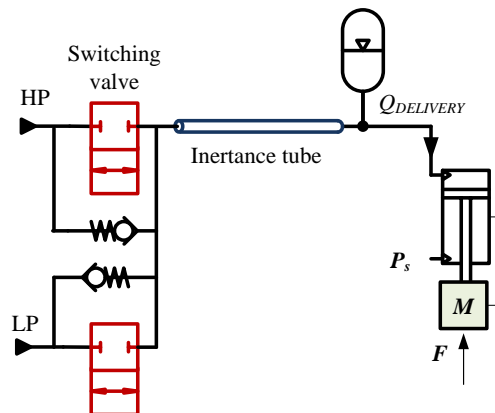
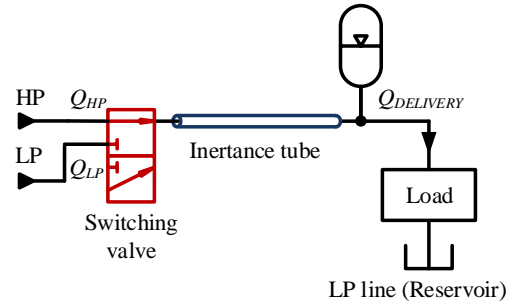
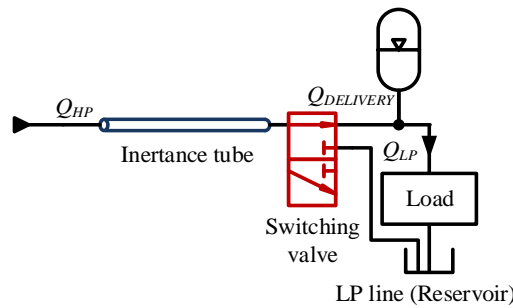

Fig. 5: Configuration of an extended HBC [15]

Johnston carried out theoretical and experimental work on the switched inertance device for efficient control of pressure and flow at Bath in 2009 [4]. Detailed simulation models were developed for the flow booster and pressure booster, where the systems include a 3/2 way switching valve, an inertance tube and an accumulator, as shown in Fig. 6. In a flow booster, the common port of the inertance tube is alternately connected to the high-pressure port (HP) and the low-pressure port (LP) when it operates. In a pressure booster, the outlet of inertance tube is alternately connected to the delivery port and the reservoir. The proportion of the switching cycle during which the HP is connected (or delivery port in a pressure booster) is defined as the switching ratio.



a) A flow booster



b) A pressure booster

Fig. 6: Two configurations of a three-port SIHC [20]

The experimental work was performed using a rotary valve which had been designed as a flow pulse generator for fluid-borne noise research [21]. The valve can only be used for very short periods due to the extreme noise and vibration. The wave propagation effect was studied by Wang *et al* [22], and the optimal switching ratios and frequencies were deduced. Later, Pan *et al* developed ideal analytical distributed models of a three-port SIHC and further enhanced the models including valve switching transition dynamics, non-linearity and leakage in 2014 [23, 24]. The models were studied in the time and frequency domains and validated through numerical simulations and experiments. A commercial proportional directional valve from Parker Hannifin (*DFplus*) was used as a high-speed valve in the early stages, and later a high-speed rotary valve and a linear valve were developed and used for the purpose [25, 26].

A four-port SIHC is shown in Fig. 7, where two inertance tubes are used. The system can be considered as the combination of two three-port valve configurations with the same average delivery flow in opposite directions. The difference is that the four-port SIHC is able to reverse the direction of motion or force through the same control action, providing real four-quadrant operation and seamless changes in direction [27]. It also enables a combination of meter-in and meter-out control which can handle over-running load situations

effectively [27]. However, the four-port SIHC is not as efficient as a three-port SIHC because of an increased tube resistance in the system.

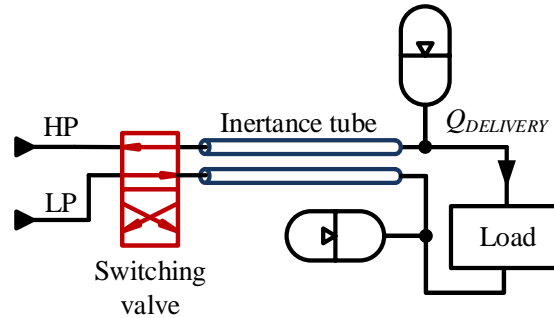

Fig. 7: Four-port SIHC structure [20]

Instead of using an inertance tube, Cao and Gu *et al* used a motor with a flywheel as the inertia component of SIHCs in the 2005[28]. Simulation of a pressure booster showed an efficiency of 58% and a flow booster showed an efficiency of 63%, with a switching frequency of 5 Hz [28]. The flow booster was used to study hydraulic pulsation by Wang *et al* in 2010 [29]. The system was modelled at a low switching frequency (below 20 Hz) and it was concluded that increasing the switching frequency and inertia of the motor could reduce the hydraulic pulsation.

As an application of the HBC, researchers in Linz collaborated with the Italian Institute of Technology to apply the HBC to control the leg of a quadruped robot [30, 31]. The experimental results showed that the HBC could track the position as well as the conventional proportional drive and achieve lower energy consumption. However, the energy-saving advantage in experiments was not as significant as simulated results because the HBC used was oversize for the application [30, 31]. The HBC was also used to control caster mould resonant drives in 2009 [32]. The simulated results showed that good efficiency was achieved but inaccuracy of motion control resulted due to the wave propagation. Kolger *et al* then proposed a flatness-based control for the HBC which made its trajectory tracking as precise as a proportional drive in simulation and experiments [33, 34]. They also designed a stepper converter and applied the similar switching concept on a knee joint exoskeleton [35-37]. The simulated results on squat motion showed good control performance and demonstrated the potential of the application but effects in real situations such as friction, leakage, weight and size were not considered in the simulation.

Pressure pulsation also occurred in an HBC configuration thus accumulators were used for noise attenuation, which adds extra compliance to the system. In 2012, Kogler and Scheidl proposed a new approach of utilizing the load capacitance to attenuate the pressure pulsations instead of an accumulator [38]. They explored a multi-HBC system and operated the HBCs in a phase shifted way to attenuate the pressure pulsations to avoid the use of accumulator at the load side. The system relied on the capacitance of the load cylinder without accumulators at the load. The simulated results showed that the velocity pulsation was significantly attenuated from a range of 0.04mm/s to 0.02mm/s in the shifted way but the results were not verified by experiment. In 2015, they further analysed the pressure response in a pipe line considering the wave propagation caused by the switching [39]. They found that optimisation of the valve size and the pipe impedance could reduce pressure oscillations in a certain range.

Recently, research has been carried out in the areas of switching loss, cavitation, fluid compressibility and parameter optimization. In 2015, Wiens *et al* modelled and quantified the switching loss for an HBC and suggested that a shaped inertance tube and a tank-flow valve positioned along the tube could reduce the switching loss. The methods were investigated in simulation, and showed increased volumetric and energy efficiencies [40, 41]. In 2018, the team proposed an improved transmission line model (TLM) for a tapered tube by optimising the weighting functions of conventional TLM models [23]. The model could be used for accurate design and modelling of tapered inertance tubes in SIHCs. Van de Ven developed a computational model to investigate the energy loss due to the fluid compressibility [42, 43]. He concluded that the switched volume between the inertia motor and the switching valve should be minimized to achieve the maximum efficiency. The model was validated in experiments and showed some discrepancies, which could be reduced by using more accurate bulk modulus measurement and fluid compressibility model [42, 43]. The group also developed a time-domain cavitation pipeline model of a pressure booster to effectively predict the condition resulting in cavitation [44]. Pan optimised the diameter and length of the inertance tube using a genetic algorithm and found global optimal parameters for designing an SIHC for maximum efficiency [45]. The approach is based on a constant delivery flow rate and could be expanded to a varying loading condition. In 2017, Wiens and Das summarized the limitations of components such as flow and pressure limits, heat transfer based on the comparison of the hydraulic and electronic converter theoretically [46].

3. MODELLING OF SWITCHED INERTANCE HYDRAULIC CONVERTERS

Research work on the modelling of SIHCs characteristics is mainly conducted in the Centre for Power Transmission and Motion Control at the University of Bath and in the Institute of Machine Design and Hydraulic Drives at Johannes Kepler University in Linz. The former concentrates on the characteristics of the three-port and four-port SHICs and their design improvements, while the latter focuses on the design of high-speed switching valves and the investigations of HBCs and their applications.

In 2009, Johnston studied the characteristics of SIHCs and the system energy efficiency [4]. Experimental results showed the actual efficiency was considerably lower than simulated results due to valve leakage and switching transition. A better designed high-speed switching valve could be used to minimize the leakage and transition effects so that the system dynamics could be further improved. Wang *et al* found that the wave propagation along the inertance tube affects system performance and the optimal operating parameters could be determined. The optimal switching frequency equates the wave period to the duration of the shorter pulse within one cycle [22]. Pressure pulsations caused by the wave effects and from the nature of switching are synchronized at the optimal frequency, thus the wave effects are almost eliminated, which leads to the highest efficiency. Their work laid the foundation for the further investigations on SIHCs.

De Negri *et al* proposed a linear analytical model of the flow booster including the linear valve resistance based on lumped components and verified the model on a pressure booster experimentally [47]. The experimental results deviated from the ideal model because the important characteristics of SIHCs such as valve switching transition, non-linearity and wave propagation were not included. Pan *et al* investigated the wave propagation effect using a distributed parameter model in the frequency domain. The team proposed mixed-domain analytical models of SIHCs, which could be used to predict the dynamic flow rate and pressure at the inlet of the inertance tube, and analyse the overall efficiency [23]. Pan *et al* concluded that ideally the flow loss (difference between actual average supply flow and delivery flow) and the flow ripple are independent of the delivery flow rate. Theoretically, the power loss is symmetrical with the switching ratio, centered on a switching ratio of 0.5. However, there are small deviations between the analytical predictions and

experimental results especially on the frequency at which the minimum flow loss and power loss occurred. This can be effectively predicted by using the enhanced analytical model which includes valve switching transition dynamics, nonlinearity and leakage [24]. The analytical and experimental results achieved from the enhanced model show that the flow loss and power loss actually increase with high delivery flow rates, and the flow loss curve is asymmetric with the minimum loss at the switching ratio slightly greater than 0.5. Using the optimal switching frequencies and ratios could significantly reduce the flow loss and power loss [23, 24]. The experimental validation was performed with low flow rates and switching frequencies due to the limitations of the switching valve and pressure pulsations. A rotary valve with a high bandwidth of more than 300 Hz was designed to construct a new SIHC prototype [25]. A maximum switching frequency of 317 Hz and a delivery flow rate of 20 L/min were applied on the prototype. The dynamic test of delivery pressure operated at 317 Hz verified that the delivery pressure is independent of the switching frequency. And the experimental result accurately showed the trend predicted by the analytical model though with a slight shift. However, when the system was operated at 20 L/min the system flow loss result deviated from the predicted result at lower switching ratio (0.2-0.4), which will be discussed in Section 5.

The analytical model of a four-port SIHC was proposed by Johnston *et al* in 2015 [27] and then validated on the SIHC prototype in 2017 [48]. The tests of upstream pressure at A port operated at zero flow rate agreed very well with both the simulated result and analytical result. The flow loss characteristic predicted by the analytical model was verified by experiments and achieved good consistency. Manhartgruber *et al* proposed a mathematical model of an HBC with two switching valves in 2005 [15]. The model includes a set of ODEs describing the actuator dynamics, a transmission line model describing the tube and a nonlinear standard valve flow equation. In 2011, Scheidl *et al* proposed a mixed time-frequency domain mathematical model of efficiency an inertance tube and a check valve [49]. The model was further extended to an HBC in 2013 [50]. The team at Linz proved the feasibility of the HBC experimentally in 2008 [51]. The experiments were performed with a fixed switching frequency and ratio. The results show an increment of 16% in efficiency of the HBC shown in Fig. 4 compared with the resistance control provided by a conventional valve. The use of a check valve also effectively prevents the back flow loss to the reservoir. Later, the team further investigated the static and dynamic flow-pressure characteristics of an HBC using varying switching ratios and loading conditions [17]. The results indicate that the change of load has almost no effect on the efficiency of an HBC and shows a maximum increased efficiency of 30% over a proportional valve controlled system.

4. DESIGN OF HIGH-SPEED SWITCHING VALVES

The high-speed switching valve is a key component of SIHCs. It switches the flow source between the high-pressure supply line and the low-pressure supply line. The performance of the high-speed valve significantly affects the characteristics of SIHCs. Therefore, the development of a high performance valve with a low resistance, large flow rate and high bandwidth is essential to the development of SIHCs. This section reviews recently developed high-speed switching valves and discussed their advantages and limitations.

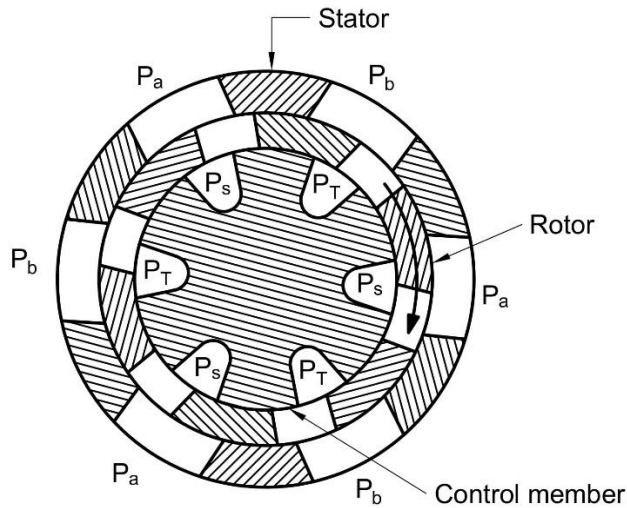

a) Rotary valve in a circular motion

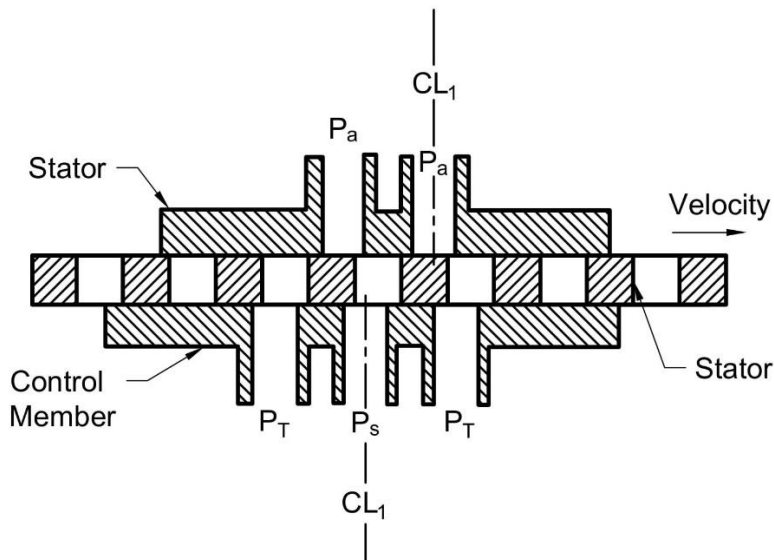

b) Rotary valve in a view of straight-line motion

Fig. 8: Schematic of the first rotary valve developed by Brown *et al* in 1988 [10]

4.1 Rotary valve

A rotary switching valve comprised of a stator and a rotor was designed for the four-port SIHC by Brown *et al* in 1988, as shown in Fig. 8 [10]. The main components of the valve arranged coaxially include the stator, the rotor and the control shaft as in Fig. 8 (a). The stator has six ports, three of which denoted P_a are connected together to be used as delivery port A, and the other three as delivery port B. In the control shaft, three ports are connected as the supply port and the other three as the tank port. When the rotor rotates, the supply port switches from the delivery port A to the delivery port B while and the tank port switches from the delivery port B to the delivery port A. The view of the straight-line motion of the valve is shown in Fig. 8 (b). The switching frequency is determined by the rotating speed of the rotor and the switching ratio is determined by the angle between the stator and the control shaft.

This rotary valve can achieve a maximum switching frequency of 500 Hz, but it is not possible to perform precise rectangular wave control at the frequency. The valve was implemented on a four-port SIHC in experiments but did not achieve the expected results due to severe cavitation. Brown *et al* concluded that the design could be improved by introducing a small accumulator-like bladder or foam pockets of gas to eliminate cavitation. They also suggested that the fundamental fluid mechanics of the unsteady cavitation, compliance, resistance and inductance of SIHCs should be thoroughly studied and understood [10].

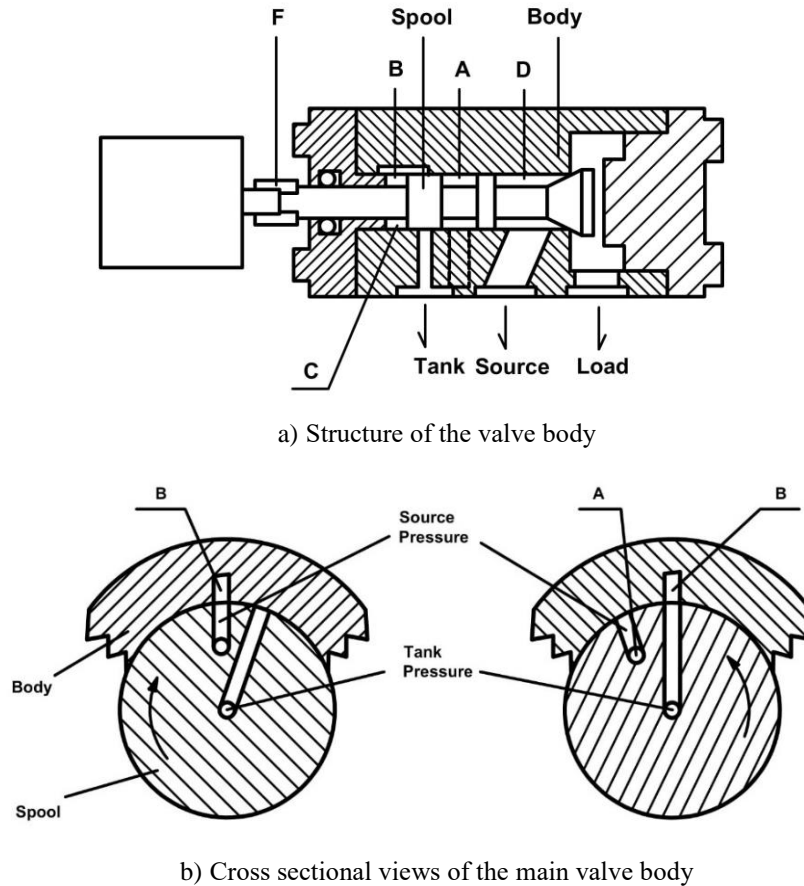

Fig. 9: A rotary spool valve developed by Cui *et al* in 1991 [52]

Another rotary valve was designed by Cui *et al* in 1991 [52]. The valve was constructed as a single-stage but acted in a two-stage way, as shown in Fig. 9. In the first stage, the motor rotates the spool to a position where the chamber B and A are connected through the slot on the spool. The pressurized fluid goes from the chamber A to chamber C via channel B, which results in a pressure imbalance between chamber C and the load volume. Therefore, the spool is moved to the right at which the load is connected to the source pressure. In the meantime, the chamber C is connected to the second stage (tank port). The spool is pushed back when the load pressure is higher than the pressure in the chamber C. The valve switches cyclically between the two stages to deliver the flow to the load. The maximum flow rate through the valve is 18 L/min at the pressure drop of 90 bar, and the switching response time is 2.5 ms. The pressure drop is high because of the complex flow path when the valve switches.

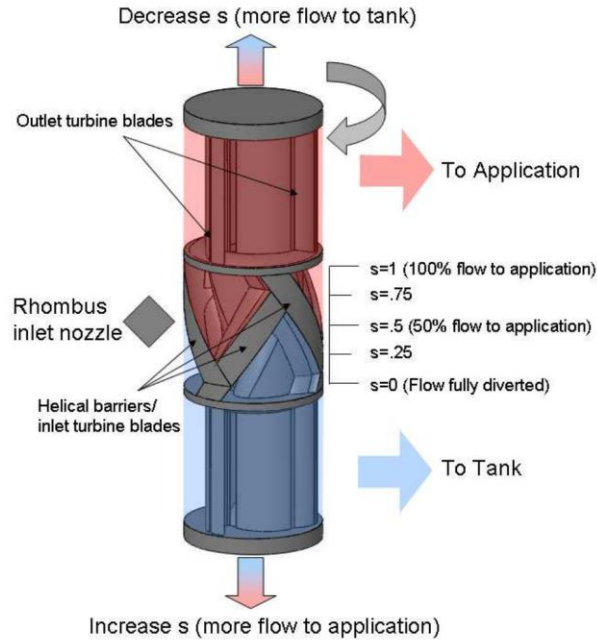

Fig. 10: A rotary valve developed by Tu *et al* in 2007 [53]

Tu *et al* designed an on/off valve based on a unidirectional rotary spool with protruding helical barriers in 2007, as shown in Fig. 10 [53]. The flow was channelled from the volume formed between the attached barriers and the house wall to the tank or the load when rotating the spool. The axial travel of the spool determines the switching duty cycle, and the rotary speed determines the switching frequency. The valve can achieve the switching frequency of 84 Hz with a flow rate of 40 L/min in simulation [53]. The experimental results showed the valve can deliver the expected flow rate for a pressure drop of 6.2 bar with a switching frequency of 15 Hz. It is also found that there is a considerable deviation between the simulated and experimental results with a higher switching frequency of 75 Hz due to the fluid compressibility effect [54]. The valve creatively utilized the flow force during the switching to self-spin the spool indicating the potential to effectively raise the system efficiency, which also simplifies the valve configuration. However, the problem is that the rotating speed (related to the switching frequency) is limited by the flow rate and affected by the fluid viscosity, making it difficult to operate the valve at a higher frequency.

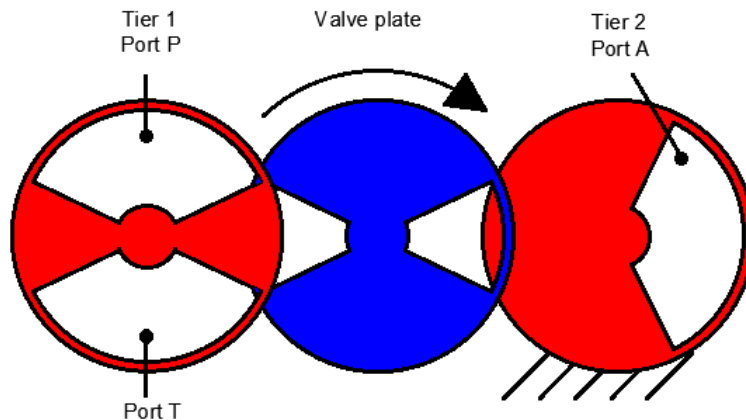

Fig. 11: A disk-based rotary valve designed by Katz *et al* in 2009 [55]

Along with various attempts for designing high-speed spool valves, the rotary concept has been employed again by Katz *et al* in 2009. They proposed a continuous phase-shift rotary valve, using a rotating valve plate between two tiers to channel the flow into different ports as shown in Fig. 11 [55, 56]. When the valve plate rotates clockwise from the initial position as in Fig. 11 the port A is connected to the port T until it reaches to 90-degree respect to the initial position. At this point, the port T is closed but the port P begins to open and be connected to the port A via the other end of the valve plate. In a cycle, the valve switches twice between the supply port P and the tank port T which doubles the switching frequency. The relative phase angle between the two tiers determines the duty ratio which is 0.5 with the position in Fig. 11, whilst the rotary speed of the valve plate determines the switching frequency. The phase-shift mode of the valve was validated in experiments and the valve can deliver a flow rate of 10 L/min at 0.5 bar pressure drop with a switching frequency of 100 Hz. Further investigation with a higher flow rate is needed to study the valve performance.

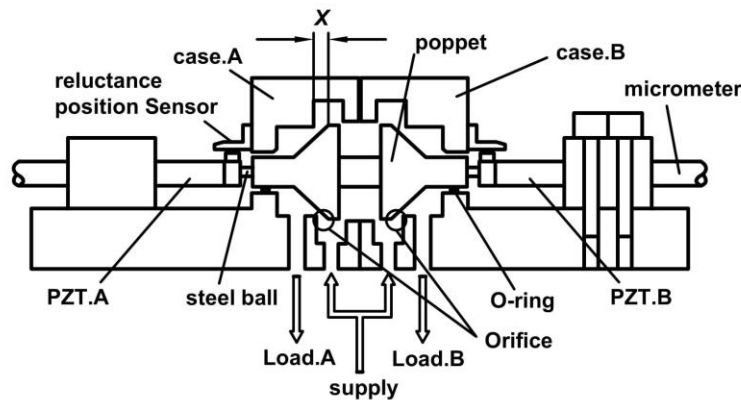

Fig. 12: Schematic of a poppet on/off valve proposed by Yokota *et al* in 1991 [57]

4.2 Linear valves

In 1991, Yokota designed a high-speed poppet valve using two multi-layered piezoelectric actuators, which enable the valve to operate with a very high frequency rectangular wave (2 kHz), as shown in Fig. 12 [57]. The design utilizes two piezoelectric actuators to strike the spool to the left and right stroke, making the supply line connected to load A and load B respectively. The poppets are driven by a pair of piezoelectric actuators of which the maximum out force is 850 N and the stroke is 15 μm with a response time of approximately 0.2 ms. The calculated maximum flow rate is 7.2 L/min at 100bar pressure drop and the steady state flow-pressure characteristics of the valve were not presented.

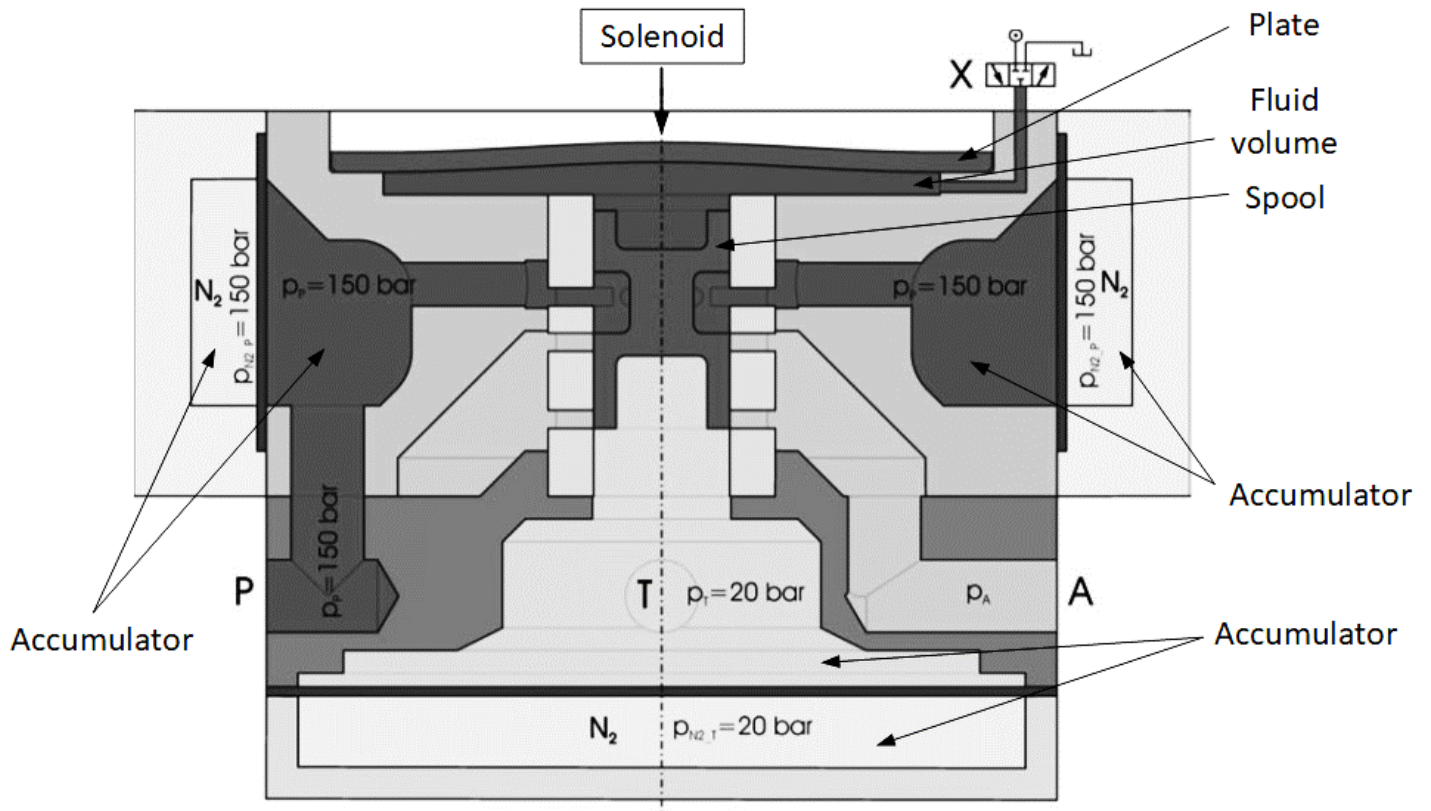

Fig. 13: The high-speed spool valve developed by Manhartsgruber *et al* in 2006 [58]

In 2006, Manhartsgruber *et al* designed a 3/3 way high-speed spool valve driven by a solenoid shown in Fig. 13 [58]. This valve features the advantage of recuperating the kinetic energy of the spool by integrating the custom-built accumulators into the valve as Fig. 13 shows.

The bottom frontal fluid volume, the spool, the plate, and the top fluid volume forms a mass-spring system with an eigenfrequency of 400 Hz. The solenoid-driven plate generates a resonant excitation of the spool through the fluid at the eigenfrequency and the spool moves upwards and downwards to deliver supply pressure and tank pressure to port A. The valve has a maximum flow rate of 100 L/min with a pressure drop of 5 bar. The solenoid-driven design made it easy to control and the resonance enabled it to switch at a high frequency with a low power input. However, the oscillation amplitude of the spool at 400 Hz was limited due to the excessive eddy-current damping which meant that the maximum flow rate was not reached at the switching frequency of 400 Hz. Further experimental validation and the performance tests are needed.

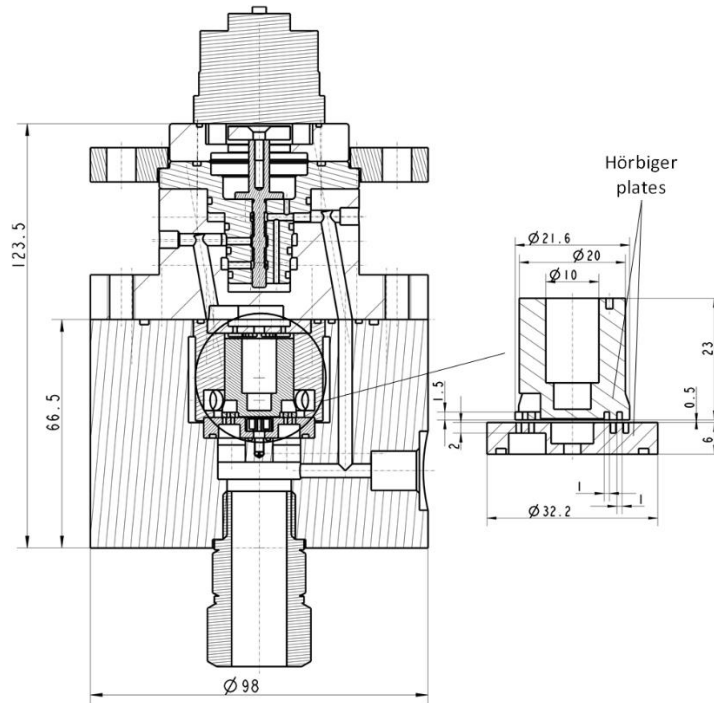

Fig. 14: A poppet valve developed by Winkler *et al* in 2007 [14]

A high-speed poppet valve employing the Hörbiger plate principle was proposed by Winkler *et al* in 2007. The valve promised a large flow passage by combining two opposite valve plates together, as shown in Fig. 14 [14]. The valve was actuated by a pilot valve with a stroke of 1mm. The valve was actuated by a 3/2 way pilot switching valve developed at the Linz Center of Mechatronics (LCM), instead of a solenoid drive. The nominal flow rate of pilot valve is about 3.5 L/min at 5 bar pressure drop and the switching time is about 1.6 ms. It is found the valve response time is very sensitive to the inlet pressure of the valve. The static-state experimental results showed that the maximum flow rate is 90 L/min with a pressure drop of 5 bar. The Hörbiger plate structure enabled a high flow rate with small poppet movement and hence small switching time.

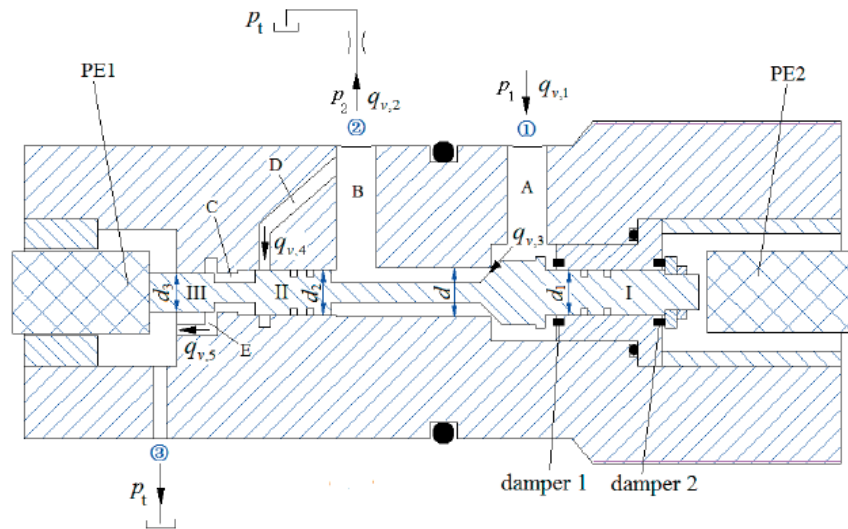

Fig. 15: A poppet valve driven by PTZ developed by Ouyang *et al* in 2008 [59]

In 2008, a piezoelectric valve was proposed by Ouyang *et al* [59]. Similar to the valve in [57], the design utilizes two piezoelectric actuators to strike the spool to the left and right stroke and stops it with the dampers. This innovative design solved the conflicts between the small displacement of the piezo (in the order of micrometres) and the relatively large stroke (in the order of millimetres) needed in the switching valve. In this way, a displacement amplifier for the piezoelectric actuator could be avoided. However, the proposed design was not prototyped, but only investigated in simulation. The simulated results showed the valve can be operated at a frequency of 250 Hz and the flow rate of 15 L/min with the supply pressure of 200bar.

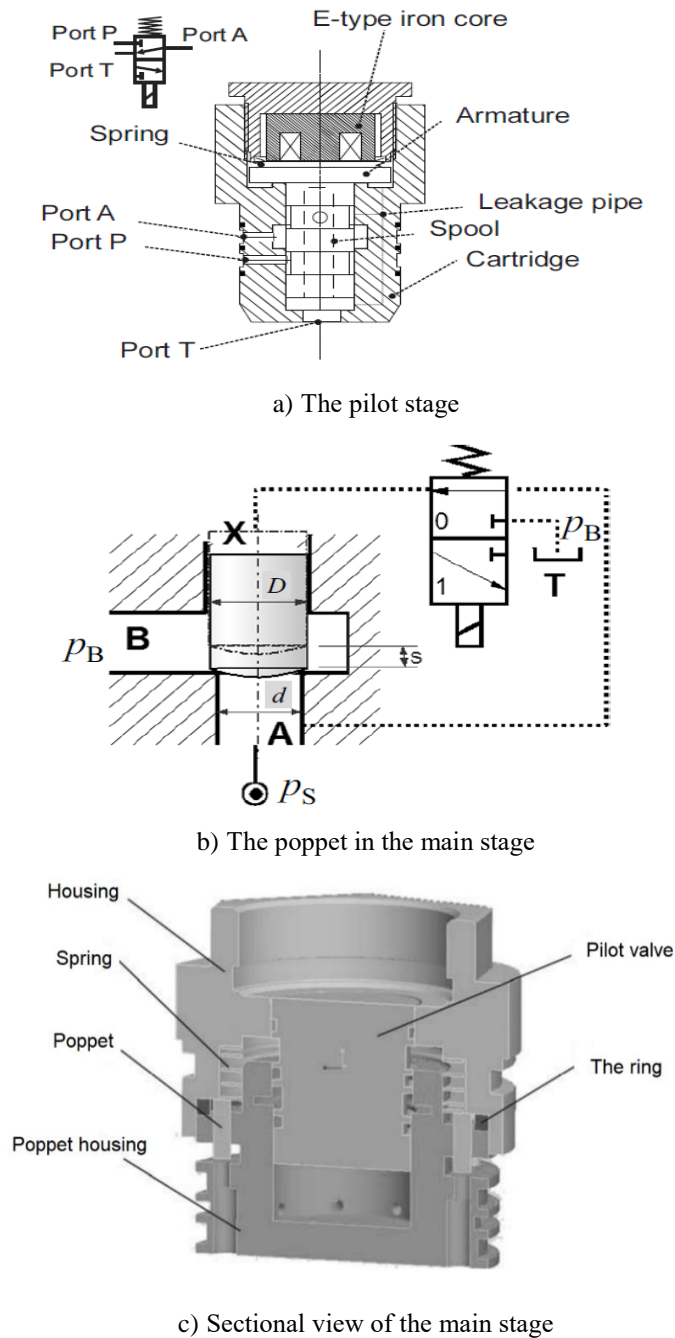

Fig. 16: A multi-poppet valve developed by Winkler *et al* in 2010 [60]

Winkler *et al* designed a multi-poppet switching valve to increase the flow rate by using multiple poppets to increase the flow capacity without increasing the response time in 2010 [60]. Figure 16a shows the solenoid-drive pilot valve they used to activate the main stage. When port A and port P are connected, it delivers the supply pressure to the port X in the main stage, which turns off the poppet as Fig. 16b shows because there is no pressure difference across the poppet. When the Port A of the pilot valve is connected to the tank port, it keeps the tank pressure at the port X in the main stage, which turns on the poppet due to higher pressure at the bottom of the poppet. The pilot valve could reach a switching time of below 2ms and a flow rate of 10 L/min under 5bar.

Poppets are arranged circularly as in Fig. 16c, which enables the valve to operate with 85 L/min with a pressure drop of 5 bar. A shim ring is used and its position is measured as the poppet position but the flexible deformation of the ring makes it difficult to determine the position of poppets since they are different. A more accurate measurement of the poppet position to calculate the switching time of the valve is needed. Despite this, using multiple small on/off valves is a novel solution, making it easy to achieve a high flow rate within a compact configuration.

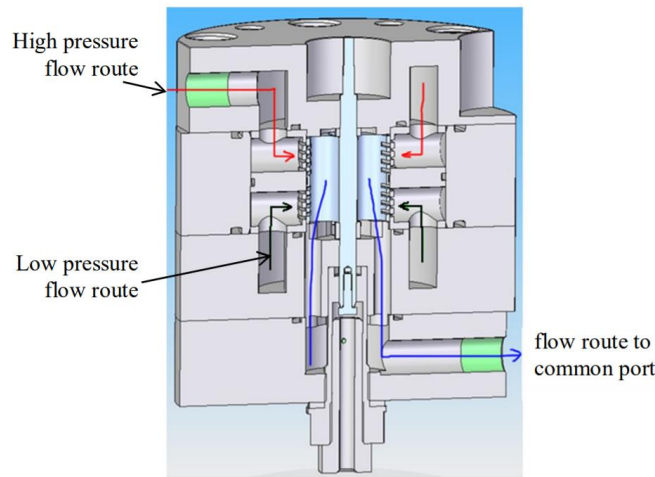

Fig. 17: A linear multi-edge spool valve developed by Kudzma *et al* in 2012 [26]

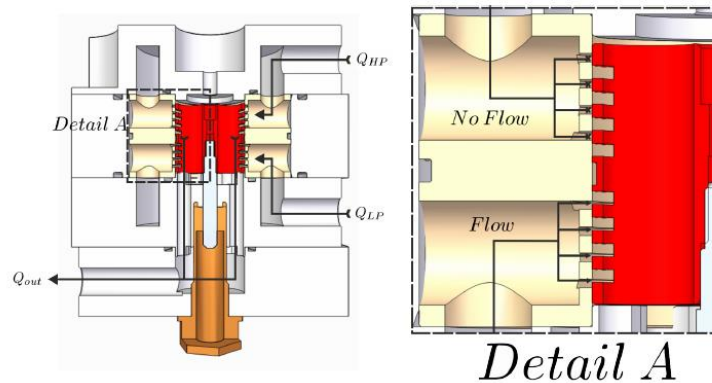
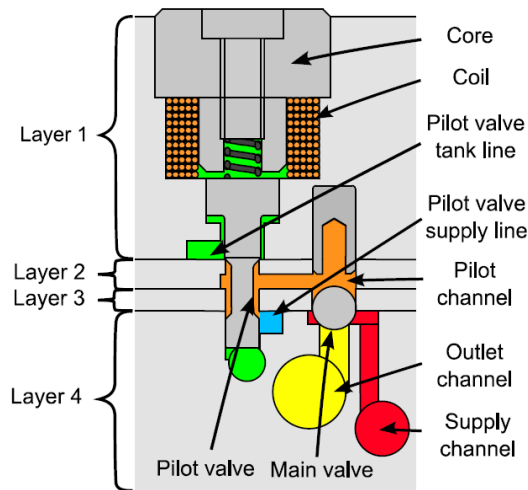

Fig. 18: Details of the multiple edges [61]

In 2012, Kudzma *et al* proposed the concept of a multi-edge spool to realize the same goal as the multi-poppet concept and designed a 2/3-way two-stage linear high-speed switching valve [26]. The spool with multiple grooves which is driven by an electrohydraulic servovalve moves inside the housing with paired grooves as shown in Fig. 17. The servovalve provides the pressure difference to move the spool to switch the input between the high-pressure supply line and the low-pressure supply line. The four pairs of metering edges in both high-pressure flow route and low-pressure flow route as Fig. 17 shows give the valve a large flow area with a small spool displacement which contributes to a shorter switching time.

The valve was anticipated to achieve 65 L/min with a pressure drop of 10 bar but actually 50 L/min was achieved at 10 bar due to the manufacturing tolerances, and the valve could switch in around 1ms and closely track a 200 Hz square wave [61]. Sell *et al* applied a state variable feedback (SVF) control system integrated with an iterative learning controller (ILC) for the position control of the valve and achieved the fastest switching time of 0.5ms. The multiple edges provide the possibility of accommodating high flow rate compared with the conventional spool valves with one metering edge. However, the multiple edges pose a challenge for manufacturing accuracy which also dictates leakage rates. Furthermore, closed loop spool position control using a servo valve instead of using a solenoid under bang-bang control considerably improved the robustness and longevity of the valve as well as reducing the vibration, though with added complexity on control.



a) A miniature switching valve in 2014 [62]



b) A miniature valve system in 2017 [63]

Fig. 19: A miniature valve system developed by Lantela *et al* in 2017 [63]

Lantela *et al* applied a similar concept to [60] and developed a miniature valve system, as shown in Fig. 19a [62]. When the pilot spool is driven to the bottom the pilot supply line is connected to the pilot channel and keeps the main stage closed. In contrast, when the pilot spool is driven to the top the pilot supply line is blocked while the tank line is connected to the pilot channel. Therefore, the main stage valve opens due to the higher pressure of the supply channel. The valve is capable of delivering a flow rate of 9 L/min at a pressure drop of 35 bar with a response time of 0.9-1.3ms. The maximum operating pressure is at least 300 bar. This gives a possibility to form a valve system with a high flow rate (70 L/min) by arranging a number of miniature switching valves in a manifold. Later, in 2017, this was realized by integrating 32 valves into a valve system to construct a 3/2 way switching valve [63] as shown in Fig. 19b. The flow rate through the valve system at a pressure difference of 35 bar reached 78 L/min. This is lower than the sum of the individual valve flows due to the leakage of approximately 0.6 L/min per pilot valve. Precise manufacturing of the pilot spool could reduce the leakage to 0.05 L/min or using a seat pilot valve is a promising alternative to minimize the leakage. Another problem is that the internal channels of the manifold are extremely complex and need to rely on some special manufacturing techniques such as the lamination method.

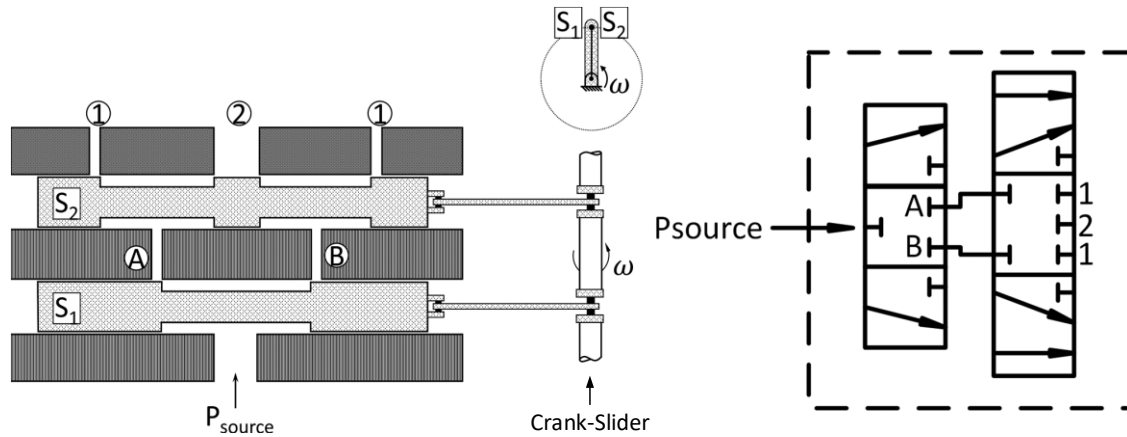

Fig. 20: The Crank-slide spool valve developed by Koptavy *et al* in 2017 [64]

In 2017, Koptavy *et al* designed a new switching valve with two spools combined and driven by a crank-slider mechanism to alternately switch the flow from the supply line to port A or port B shown in Fig. 20 [64]. The valve showed very good performance with a maximum switching frequency of 120 Hz and a flow rate of 22.7 L/min. The leakage of the valve is very low (0.065 L/min), when tested at the pressure difference of 194bar and at the rotating speed of the input shaft of the crank-slider of less than 0.32rad/s [64]. This mechanism was able to recuperate the energy with a flywheel and avoided the bang-bang actuation with a solenoid, or the throttling process with a servo valve, thus minimized the energy needed in the pilot stage and greatly simplified the control strategy. A possible problem is that the crank-slider mechanism makes the valve bulky.

4.3 Valve effects and comparison between the valves

A high-speed switching valve is the key component of an SIHC and significantly affects the SIHC performance. The valve bandwidth determines the highest switching frequency that the SIHC can achieve, as well as the length of the inertance tube required. A shorter inertance tube can be used if a very high-speed switching valve is available, which can reduce hydraulic resistance and improve efficiency. The valve resistance and leakage highly depend on the design and manufacturing accuracy of the valve. Different designs lead to a variety of flow-pressure drop characteristics, and leakage directly corresponds to a power loss in the valve.

The development of SIHCs is currently limited by the performance of high-speed valves. The valve needs to deliver high flow rates with low pressure drop, switch fast, have low leakage and require low driving energy. The valve is also expected to provide good controllability and have reasonable manufacturing costs. Table 1 summarizes the designs and performance of some of the high-speed switching valves developed in recent years. The advantages and limitations of the designs have been discussed.

In a spool valve, it is relatively easy to perform position control of a spool driven by solenoids, a hydraulic pilot stage or piezoelectric actuators. In addition, manufacture of a spool and its housing with good accuracy is standard practice. It is possible to achieve good performance such as a high flowrate and a low pressure drop using a spool design. A good example is the solenoid-driven linear spool valve developed by Winkler [60], which successfully achieved 90 L/min at only 5 bar pressure drop. But the mass of the spool makes it difficult and energy-consuming to be driven at a high frequency and maintain a relatively large stroke. One design to solve this problem is to have multiple smaller orifices on the spool [26]. Therefore, a small displacement of the spool such as 0.1mm is enough to switch between the ports and maintain a high flow rate. The other approach is to introduce more efficient actuation, for example, a crank-slider mechanism is used to recuperate the energy needed in moving the spool [64], at the expense of flexibility in spool positioning.

Table 1 Summary of high-speed switching valve design

Valve construction	Spool	Spool	Spool	Poppet	Poppet	Poppet	Rotary	Rotary
Valve driven mechanism	Solenoid	Servo valve	Crank-slider	Piezoelectric	Pilot valve	Pilot valve	Motor	Self-spin
Features	Fluid spring	Multi-grooves	Efficient actuation	Small stroke	Multi-poppet	Multi-valve system	Disk-based	Turbine blades
Response time/ Repeating frequency	400 Hz	0.5 ms	120 Hz	250 Hz	1.5-2.0 ms	2.5 ms	100 Hz	15 Hz
Flow pressure characteristics	100 L/min @5bar	50 L/min @10bar	22.7 L/min	10 L/min	85 L/min @5bar	78 L/min @35bar	10 L/min	40 L/min @6.2bar
Advantages	Easy control and manufacture	High flow rate; quick switching	Energy-saving; smooth switching	High frequency	High flow rate; short switching time		Simply driven approach	
Limitations	Stroke and flow limit at high frequency	Complicated control and high leakage	Bulky and low flow rate	Low flowrate	Complex inner channels and difficulty in simultaneously switching		Friction loss	Fluid compressibility
Examples	Manhartsguber et al [58]	Kudzma et al [26]	Koktavy et al [64]	Ouyang et al [59]	Winkler et al [60]	Lantela et al [63]	Katz et al [55]	Tu et al [53]

Using a poppet valve could simplify the actuation stage because it is easier to open or close with a small initial force. Piezoelectric actuators could be used to strike the poppet in both directions making it possible to switch at a high frequency. This idea was first proposed by Yokota [57] in 1991 and later similar idea was used by Ouyang to build a high-speed switching valve in [59] and the valve could be operated at 250 Hz with a flow rate of 15L/min in simulation.

For a rotary valve, it is easy to drive at a high frequency by increasing the speed of the motor [10, 55]. There are two common problems in the rotary valve: one is the friction loss during the rotation and the other is the energy loss due to flow throttling and fluid compressibility. These problems limit the switching frequency and the flow rate of the rotary valve. Further improvements on the design are needed to minimize these effects.

The multi-poppet valve and multi-valve system are used to achieve higher flow rate while maintaining a fast response time. Two examples of this principle are the valves developed by Winkler et al [60] and Lantela et al [63]. Higher flow rates can be achieved with an increasing number of valves or poppets. However, it is difficult to keep all the poppets or valves acting simultaneously. A design of integrating all the poppets into one component could be a solution to this. However, the internal channels used to actuate the main stage are complicated and difficult to manufacture. Recently, the additive manufacturing technique provides an opportunity to manufacture the complex geometry of the valve body though it might not be cost-effective.

5. DISCUSSION

Pan *et al* and Scheidl *et al* have made progress in building analytical models of SIHCs which can represent their characteristics well. The models show generally good agreement with experimental results, but there are still some inaccuracies. For example, the flow loss is effectively reduced by varying switching frequency with different switching ratios as the optimal curves show in Fig. 21. However, the optimal curve for the delivery flow rate of 20 L/min and 0 L/min are expected to have similar trends but there is an unexpected deviation between them as the red arrow shows in Fig. 21. This deviation could be caused by the transition dynamics with a large delivery flow rate, the variation of the operating temperature, valve dynamics or system cavitation, and should be a matter for future research.

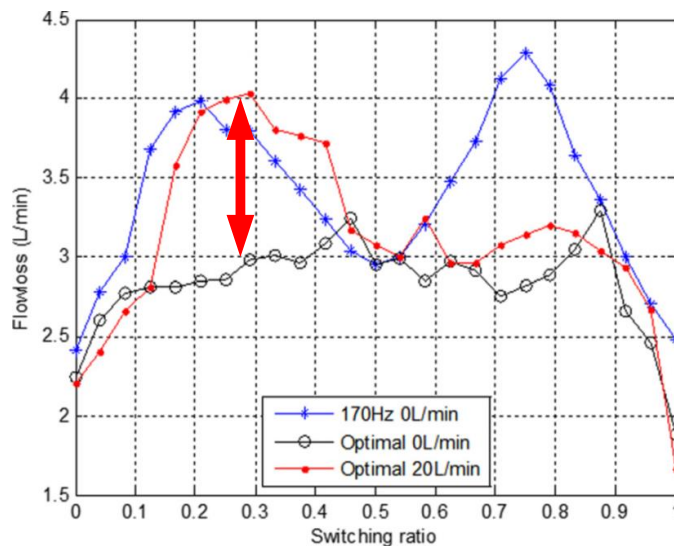

Fig. 21: Experimental relationship between the switching ratio and flow loss [24]

The previous work into modelling the SIHC characteristic and the valve design shows that there is plenty of room for improvement in terms of design parameters of systems and components, and research to optimise these is ongoing. Pan used a genetic algorithm to find the optimal tube diameter and tube length of a SIHC based on the analytical models given in [23, 24]. The optimisation starts with setting the initial values of the diameter and tube length and then the switching frequency and period are calculated under the optimal condition in [22]. The genetic algorithm is used to search for the optimal value of the two tube parameters to minimize the cost function of power loss which is given in [23]. The result indicated that the length of 0.62m and the diameter of 9.5mm gives the lowest power loss which is almost half of that at the length of 3m. However, this set of parameters needs a high switching frequency (544 Hz) which is difficult to achieve. Ven der Buhs *et al* also optimised the shape of the inertance tube and found the optimal arrangement of various tapered tubes is 6% better in efficiency compared with the uniform tubes when used in a SIHC [65]. The optimised shape of the inertance tube includes a uniform section of the tube and a diverging tapered section followed by another uniform section at larger diameter and with lower resistance as in Fig. 22. However, in general there is not much research into design optimization of SIHCs and this needs to be more investigated thoroughly in the future.

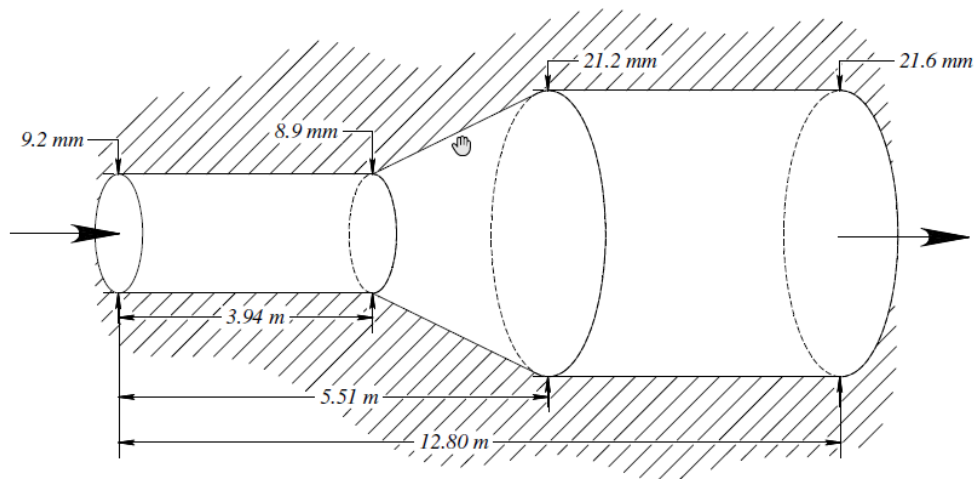

Fig. 22: The arrangement of the various shaped tube [65]

6. CONCLUSIONS

The switched inertance hydraulic converter is a very promising concept to achieve high energy efficiency compared with conventional valve-controlled systems. This article reviewed the recent development of SIHCs particularly focusing on the configurations of SIHCs, the designs of high-speed switching valves and the optimisation of SIHC parameters.

Analytical models for SIHCs are presented in the research literature, and these are validated by experimental results, but there are still deviations particularly when SIHCs are operated with high flow rate. This may indicate that the analytical models could be further enhanced by considering cavitation.

Developing a high-speed switching valve is the key to realizing high-efficiency SIHCs. In most papers, the SIHCs were operated at a relatively low frequency, typically under 100 Hz, due to the limitation of the switching valve. Prototype high-speed switching valves

designed since 1988 have been summarized and compared, and the advantages and limitations of different designs are evaluated and discussed. The static performance of the valves are promising but their dynamics are not yet sufficient to meet the typical requirements of SIHCs. The challenge of designing a mechanical and actuation arrangement that provides a very high switching speed has yet to be fully solved, compounded by the need to manufacture to tight tolerances. Design parameter optimisation on SIHC systems and switching valves could help generate better designs to maximize performance and efficiency.

Future research should be carried out into the design, control and optimisation of linear and rotary high-speed switching valves. Faster, high flow, low leakage valves can further improve the efficiency of SIHCs. Analytical models can be enhanced by including cavitation, valve dynamics and loading resonance effects on SIHCs, and can be used for investigating the influence of valve switching transition in more detail. The investigation of SIHCs in a variety of configurations is desired to complete systematic models as current work is mainly based on switched buck converters (flow boosters). Configurations such as switched booster converters (pressure boosters) and four-port SIHCs need to be investigated and evaluated for efficiency. Control of the high-speed switching valves is also a good area to explore. The accuracy and robustness of the valve switching can significantly affect SIHC performance. Experimental investigations using higher operating pressures and flow rates are necessary for practical hydraulic applications that include robotics, transportation, oil and gas, and machinery for industry, construction and agriculture. The cyclic switching mechanism of SIHCs generates periodic pressure pulsation which also needs to be addressed to eliminate noise problems associated with this new technology.

ACKNOWLEDGMENTS

This work was supported by the UK Engineering and Physical Sciences Research Council under grant number EP/P022022/1, together with Airbus Group Limited, Parker Hannifin Corporation (World Wide) and Zhejiang University. The authors would like to thank China Scholarship Council to support the PhD student Chenggang Yuan (201706150102) studying at the University of Bath, UK.

REFERENCES

- [1] Yuan, C., Pan, M., and Plummer, A., 2018, "A review of switched inertance hydraulic converter technology". In ASME/BATH 2018 Symposium on Fluid Power and Motion Control, American Society of Mechanical Engineers Digital Collection.
- [2] Scheidl, R., and Riha, G., 1999, "Energy efficient switching control by a hydraulic 'resonance-converter'". In Workshop on Power Transmission and Motion Control (PTMC'99), CR Burrows and K. Edge, eds., Bath, UK, Sept, pp. 8-11.
- [3] Gradl, C., 2017, "Hydraulic Stepper Drive—Conceptual Study, Design and Experiments". Thesis (Ph.D.), Johannes Kepler University, Linz.
- [4] Johnston, D. N., 2009, "A switched inertance device for efficient control of pressure and flow". In ASME 2009 Dynamic Systems and Control Conference, American Society of Mechanical Engineers, pp. 589-596.
- [5] Love, L., Eric, L., and Pete, A., 2012, "Estimating the impact (energy, emissions and economics) of the US fluid power industry". No. TN, Oak Ridge National Laboratory (ORNL), Oak Ridge.
- [6] de Montgolfier, J. M., 1803, "Note on the hydraulic ram, and on the method of calculating its effects". *des Mines*, **13**(73), pp. 42–51.
- [7] Constantinesco, G., and Haddon, W., 1916, "Hydraulic transmission of power; liquid-pressure engines. A motor operated by periodic impulses produced in a liquid-wave-transmission". Patent GB109849, UK.
- [8] Dulay, I. K., 1988, *Fundamentals of hydraulic power transmission*. North-Holland.
- [9] Brown, F. T., 1987, "Switched reactance hydraulics: A new way to control fluid power". In National Conference on Fluid Power, pp. 25-34.
- [10] Brown, F., Tentarelli, S., and Ramachandran, S., 1988, "A hydraulic rotary switched-inertance servo-transformer". *Journal of Dynamic Systems, Measurement, and Control*, **110**(2), pp. 144-150.
- [11] Liaw, C. J., and Brown, F. T., 1990, "Nonlinear dynamics of an electrohydraulic flapper nozzle valve". *Journal of Dynamic Systems Measurement and Control-Transactions of the Asme*, **112**(2), pp. 298-304.
- [12] Scheidl, R., Schindler, D., Riha, G., and Leitner, W., 1995, "Basics for the energy-efficient control of hydraulic drives by switching techniques". In Proceedings of the Third Conference on Mechatronics and Robotics, pp. 118-131.

- [13] Winkler, B., and Scheidl, R., 2006, "Optimization of a fast switching valve for big flow rates". In Bath Workshop on Power Transmission and Motion Control, PTMC, Citeseer, pp. 387-399.
- [14] Winkler, B., and Scheidl, R., 2007, "Development of a fast seat type switching valve for big flow rates". In The 10th Scandinavian International Conference on Fluid Power.
- [15] Manhartsgruber, B., Mikota, G., and Scheidl, R., 2005, "Modelling of a switching control hydraulic system". *Mathematical and Computer Modelling of Dynamical Systems*, **11**(3), pp. 329-344.
- [16] Scheidl, R., Kogler, H., and Manhartsgruber, B., 2007, "A cavitation avoidance strategy in hydraulic switching control based on a nonlinear oscillator". In Proceedings of The 10th Scandinavian International Conference on Fluid Power.
- [17] Kogler, H., and Scheidl, R., 2008, "Two basic concepts of hydraulic switching converters". In The first workshop on digital fluid power, pp. 7-30.
- [18] Kogler, H., Scheidl, R., Ehrentraut, M., Guglielmino, E., Semini, C., and Caldwell, D. G., 2010, "A compact hydraulic switching converter for robotic applications". In Proceedings of fluid power and motion control, pp. 55-66.
- [19] Guglielmino, E., Semini, C., Kogler, H., Scheidl, R., and Caldwell, D. G., 2010, "Power hydraulics-switched mode control of hydraulic actuation". In Proceedings of the 2010 IEEE/RSJ international conference on intelligent robots and systems (IROS 2010), IEEE, pp. 3031-3036.
- [20] Pan, M., and Plummer, A., 2018, "Digital switched hydraulics". *Frontiers of Mechanical Engineering*, pp. 1-7.
- [21] Johnston, D. N., and Drew, J., 1996, "Measurement of positive displacement pump flow ripple and impedance". *Proceedings of the Institution of Mechanical Engineers, Part I: Journal of Systems and Control Engineering*, **210**(1), pp. 65-74.
- [22] Wang, P., Kudzma, S., Johnston, N., Plummer, A., and Hillis, A., 2011, "The influence of wave effects on digital switching valve performance". In The fourth workshop on digital fluid power, Austrian Center of Competence in Mechatronics.
- [23] Pan, M., Johnston, N., Plummer, A., Kudzma, S., and Hillis, A., 2014, "Theoretical and experimental studies of a switched inertance hydraulic system". *Proceedings of the Institution of Mechanical Engineers, Part I: Journal of Systems and Control Engineering*, **228**(1), pp. 12-25.
- [24] Pan, M., Johnston, N., Plummer, A., Kudzma, S., and Hillis, A., 2014, "Theoretical and experimental studies of a switched inertance hydraulic system including switching transition dynamics, non-linearity and leakage". *Proceedings of the Institution of Mechanical Engineers, Part I: Journal of Systems and Control Engineering*, **228**(10), pp. 802-815.
- [25] Pan, M., Johnston, N., Robertson, J., Plummer, A., Hillis, A., and Yang, H. Y., 2015, "Experimental investigation of a switched inertance hydraulic system with a high-speed rotary valve". *Journal of Dynamic Systems Measurement and Control-Transactions of the ASME*, **137**(12).
- [26] Johnston, N., Kudzma, S., Plummer, A., Sell, N., Hillis, A., and Pan, M., 2012, "A high flow fast switching valve for digital hydraulic systems". In The Fifth Workshop on Digital Fluid Power, University of Bath.
- [27] Johnston, N., Pan, M., Plummer, A., Hillis, A., and Yang, H., 2015, "Theoretical studies of a switched inertance hydraulic system in a four-port valve configuration". In The Seventh Workshop on Digital Fluid Power, University of Bath.
- [28] Cao, J., Gu, L., Wang, F., and Qiu, M., 2005, "Switchmode hydraulic power supply theory". In ASME 2005 International Mechanical Engineering Congress and Exposition, American Society of Mechanical Engineers Digital Collection, pp. 85-91.
- [29] Wang, F., and Gu, L., 2010, "Improving characteristic of switching hydraulic system based on high-speed on/off valves". In ASME/BATH 2010 Symposium on Fluid Power and Motion Control, pp. 99-111.
- [30] Guglielmino, E., Semini, C., Yang, Y. S., Caldwell, D., Kogler, H., and Scheidl, R., 2009, "Energy efficient fluid power in autonomous legged robotics". In Proceeding of the ASME 2009 dynamic systems and control conference (DSCC 2009).
- [31] Peng, S., Kogler, H., Guglielmino, E., Scheidl, R., Branson, D. T., and Caldwell, D. G., 2013, "The use of a hydraulic DC-DC converter in the actuation of a robotic leg". In 2013 IEEE/RSJ International Conference on Intelligent Robots and Systems, pp. 5859-5864.
- [32] Kogler, H., and Scheidl, R., 2010, "Hydraulic switching control of resonant drives". In Proceedings of the 12th Mechatronics Forum Biennial International Conference, pp. 28-30.
- [33] Kogler, H., and Scheidl, R., 2015, "Linear motion control with a low-power hydraulic switching converter-Part I: Concept, test rig, simulations". *Proceedings of the Institution of Mechanical Engineers, Part I: Journal of Systems and Control Engineering*, **229**(8), pp. 677-684.
- [34] Kogler, H., and Scheidl, R., 2015, "Linear motion control with a low-power hydraulic switching converter-Part II: Flatness-based control". *Journal of Systems and Control Engineering, Part I*, **229**(9), pp. 818-828.
- [35] Gradl, C., Plockinger, A., and Scheidl, R., 2016, "Sensorless position control with a hydraulic stepper drive - Concept, compression modeling and experimental investigation". *Mechatronics*, **35**, pp. 91-101.
- [36] Gradl, C., and Scheidl, R., 2017, "Performance of an Energy Efficient Low Power Stepper Converter". *Energies*, **10**(4).
- [37] Holl, E., Scheidl, R., and Eshkabilov, S., 2017, "Simulation study of a digital hydraulic drive for a knee joint exoskeleton". In ASME/BATH 2017 Symposium on Fluid Power and Motion Control, American Society of Mechanical Engineers.
- [38] Kogler, H., and Scheidl, R., 2012, "The hydraulic buck converter exploiting the load capacitance". In Proceedings of the 8th International Fluid Power Conference (8. IFK), pp. 26-28.

- [39] Kogler, H., Scheidl, R., and Schmidt, B. H., 2015, "Analysis of wave propagation effects in transmission lines due to digital valve switching". In ASME/BATH 2015 Symposium on Fluid Power and Motion Control, American Society of Mechanical Engineers.
- [40] Wiens, T. K., 2015, "Analysis and mitigation of valve switching losses in switched inductance converters". In ASME/BATH 2015 Symposium on Fluid Power and Motion Control, American Society of Mechanical Engineers.
- [41] Wiens, T., 2016, "Improving performance of a switched inductance buck converter via positioning of reservoir flow valve". *Journal of Dynamic Systems, Measurement, and Control*, **138**(12), p. 124502.
- [42] Van de Ven, J. D., 2013, "On fluid compressibility in switch-mode hydraulic circuits-part I: Modeling and analysis". *Journal of Dynamic Systems Measurement and Control-Transactions of the Asme*, **135**(2).
- [43] Van de Ven, J. D., 2013, "On fluid compressibility in switch-mode hydraulic circuits-part II: Experimental results". *Journal of Dynamic Systems Measurement and Control-Transactions of the Asme*, **135**(2).
- [44] Yudell, A. C., and Van de Ven, J. D., 2017, "Experimental validation of a time domain cavitation model for switched inductance circuits". In ASME/BATH 2017 Symposium on Fluid Power and Motion Control, American Society of Mechanical Engineers.
- [45] Pan, M., 2017, "A global optimisation of a switched inductance hydraulic system based on genetic algorithm". In Proceedings of 15th Scandinavian International Conference on Fluid Power, Linköping University Electronic Press, pp. 302-308.
- [46] Wiens, T., and Das, D., 2017, "A comparison of hydraulic and electrical switch-mode converters". In ASME/BATH 2017 Symposium on Fluid Power and Motion Control, American Society of Mechanical Engineers.
- [47] De Negri, V. J., Wang, P., Plummer, A., and Johnston, D. N., 2014, "Behavioural prediction of hydraulic step-up switching converters". *International journal of fluid power*, **15**(1), pp. 1-9.
- [48] Pan, M., Plummer, A., and El Agha, A., 2017, "Theoretical and experimental studies of a switched inductance hydraulic system in a four-port high-speed switching valve configuration". *Energies*, **10**(6).
- [49] Scheidl, R., Manhartgruber, B., and Kogler, H., 2011, "Mixed time–frequency domain simulation of a hydraulic inductance pipe with a check valve". *Proceedings of the Institution of Mechanical Engineers, Part C: Journal of Mechanical Engineering Science*, **225**(10), pp. 2413-2421.
- [50] Kogler, H., Scheidl, R., and Ehrentraut, M., 2013, "A simulation model of a hydraulic buck converter based on a mixed time frequency domain iteration". In ASME/BATH 2013 Symposium on Fluid Power and Motion Control, American Society of Mechanical Engineers.
- [51] Scheidl, R., Manhartgruber, B., Kogler, H., Winkler, B., and Mairhofer, M., 2008, "The hydraulic buck converter-concept and experimental results". In Proceedings of the Sixth International Conference on Fluid Power.
- [52] Cui, P., Burton, R. T., and Ukrainetz, P., 1991, "Development of a high speed on/off valve". *SAE transactions*.
- [53] Tu, H. C., Rannow, M. B., Van de Ven, J. D., Wang, M., Li, P. Y., and Chase, T. R., 2007, "High speed rotary pulse width modulated on/off valve". In ASME 2007 International Mechanical Engineering Congress and Exposition, American Society of Mechanical Engineers, pp. 89-102.
- [54] Tu, H. C., Rannow, M. B., Wang, M., Li, P. Y., and Chase, T. R., 2009, "Modeling and validation of a high speed rotary PWM on/off valve". In ASME 2009 Dynamic Systems and Control Conference, American Society of Mechanical Engineers, pp. 629-636.
- [55] Katz, A. A., and Van de Ven, J. D., 2009, "Design of a high-speed on-off valve". In ASME 2009 International Mechanical Engineering Congress and Exposition, American Society of Mechanical Engineers, pp. 237-246.
- [56] Van de Ven, J. D., and Katz, A., 2011, "Phase-shift high-speed valve for switch-mode control". *Journal of Dynamic Systems, Measurement, and Control*, **133**(1), p. 011003.
- [57] Yokota, S., and Akutu, K., 1991, "A fast-acting electro-hydraulic digital transducer: A poppet-type on-off valve using a multilayered piezoelectric device". *JSME International Journal, Series 2: Fluids Engineering, Heat Transfer, Power, Combustion, Thermophysical Properties*, **34**(4), pp. 489-495.
- [58] Manhartgruber, B., 2006, "A hydraulic control valve for PWM actuation at 400 Hz". In Power Transmission and Motion Control-PTMC, pp. 373-385.
- [59] Ouyang, X., Yang, H., Jiang, H., and Xu, B., 2008, "Simulation of the piezoelectric high-speed on/off valve". *Chinese Science Bulletin*, **53**(17), pp. 2706-2711.
- [60] Winkler, B., Ploeckinger, A., and Scheidl, R., 2010, "A novel piloted fast switching multi poppet valve". *International Journal of Fluid Power*, **11**(3), pp. 7-14.
- [61] Sell, N., Johnston, N., Plummer, A., and Kudzma, S., 2015, "Development of a position controlled digital hydraulic valve". In ASME/Bath 2015 Symposium on Fluid Power and Motion Control, American Society of Mechanical Engineers.
- [62] Lantela, T., Kajaste, J., Kostamo, J., and Pietola, M., 2014, "Pilot operated miniature valve with fast response and high flow capacity". *International Journal of Fluid Power*, **15**(1), pp. 11-18.
- [63] Lantela, T., and Pietola, M., 2017, "High-flow rate miniature digital valve system". *International Journal of Fluid Power*, **18**(3), pp. 188-195.
- [64] Koktavy, S. E., Yudell, A. C., and Van de Ven, J. D., 2017, "Design of a crank-slider spool valve for switch-mode circuits with experimental validation". *Journal of Dynamic Systems, Measurement, and Control*, **140**(6).

[65] Wiens, T. K., Chen, D. X., Bergstrom, D. J., and Chowdhury, N. A., 2018, "Investigation and Optimization of Hydraulic Step-down Switched Inertance Converters with Non-uniform Inertance Tubes". Thesis (M.A.), University of Saskatchewan, Saskatoon.

LIST OF FIGURE AND TABLE CAPTIONS

- Fig. 1: Electrical buck converter and a three-port SIHC
- Fig. 2: Recent publications cited in this review (2003-2018)
- Fig. 3: Research areas of switched inertance hydraulic converters
- Fig. 4: Configuration of a typical HBC [15]
- Fig. 5: Configuration of an extended HBC [15]
- Fig. 6: Two configurations of a three-port SIHC [20]
- Fig. 7: Four-port SIHC structure [20]
- Fig. 8: Schematic of the first rotary valve developed by Brown et al in 1988 [10]
- Fig. 8: a) Rotary valve in a circular motion
- Fig. 8: b) Rotary valve in a view of straight-line motion
- Fig. 9: A rotary spool valve developed by Cui *et al* in 1991 [52]
- Fig. 9: a) Structure of the valve body
- Fig. 9: b) Cross sectional views of the main valve body
- Fig. 10: A rotary valve developed by Tu *et al* in 2007 [53]
- Fig. 11: A disk-based rotary valve designed by Katz *et al* in 2009 [55]
- Fig. 12: Schematic of a poppet on/off valve proposed by Yokota *et al* in 1991 [57]
- Fig. 13: The high-speed spool valve developed by Manhartgruber *et al* in 2006 [58]
- Fig. 14: A poppet valve developed by Winkler *et al* in 2007 [14]
- Fig. 15: A poppet valve driven by PTZ developed by Ouyang *et al* in 2008 [59]
- Fig. 16: A multi-poppet valve developed by Winkler *et al* in 2010 [60]
- Fig. 16: a) The pilot-stage
- Fig. 16: b) The poppet in the main stage
- Fig. 16: c) Sectional view of the main stage
- Fig. 17: A linear multi-edge spool valve developed by Kudzma et al in 2012 [26]
- Fig. 18: Details of the multiple edges [61]
- Fig. 19: A miniature valve system developed by Lantela *et al* in 2017 [63]
- Fig. 19: a) A miniature switching valve in 2014 [62]
- Fig. 19: b) A miniature valve system in 2017 [63]
- Fig. 20: The Crank-slide spool valve developed by Koktavay *et al* in 2017 [64]
- Fig. 21: Experimental relationship between the switching ratio and flow loss [24]
- Fig. 22: The arrangement of the various shaped tube [65]
- Tab. 1 Summary of high-speed switching valve design