

Utilising SCM – MIMO Channel Model Based on V-BLAST Channel Coding in V2V Communication

Ahmad Baheej Al-Khalil, Scott Turner, and Ali Al-Sherbaz

The University of Northampton, School of Science and Technology, St. Georg Avenue,
Northampton NN2 6JD, UK
{ahmad.al-khalil, scott.turner, ali.al-sherbaz}@northampton.ac.uk

Abstract. Vehicular ad hoc networks VANETs has recently received significant attention in intelligent transport systems (ITS) research. It provides the driver with information regarding traffic and road conditions which is needed to reduce accidents, which will save many people's lives. In Vehicle-to-vehicle V2V communication the high-speed mobility of the nodes is the challenge, which significantly affects the reliability of communication. In this paper the utilising of SCMMIMO channel model, (which is based on V-BLAST channel coding) is present to evaluate the performance of the PHY layer in V2V communication. The simulation results observed that the SCM model can overcome the propagation issues such as path loss, multipath fading and shadowing loss. The simulation considered three different environments, high, medium and low disruptions in urban traffic.

Keywords: VANETs; V2V; MIMO; SCM; V-BLAST.

1 Introduction

In the recent years the advent of Vehicular Ad-hoc Networks VANETs considers one of the most important developments in the wireless communications systems. In a recent United Nation UN road safety report around the world, it was documented that road safety deaths made up 2.2% of the leading causes of death in 2004. It has been predicted that this will rise to 3.6% by 2030. There have been recommendations made by the Global Status Report regarding the poor collaboration between the sectors made responsible for collecting and reporting data on road traffic incidents. These recommendations have also included communication between the police, health and transport services and their ability to man such operations [1]. There is therefore a need to provide the driver with information regarding traffic and road conditions to reduce these incidents, thus will keep many people's lives. VANETs is a technology which uses the moving vehicles as nodes in the wireless network, which also considers as a special case of the Mobile Ad-hoc Networks MANETs [2]. VANETs is dedicated to exchange the messages between the vehicles in two forms: vehicle to vehicle V2V and vehicle to infrastructure V2I [3]. The aim of the use of VANETs technology is to produce a full wireless communication solution among vehicles, to satisfy the safety and the comfortable applications requirements such as less congestion, accident warning, road exploration, etc. An important advantage of VANETs is battery power is generated during the journey, providing an extended battery life.

The paper is organized as follows. In Section 2, important general background information on VANETs standards, MIMO technology with VANETs and V-BLAST coding are provided. The SCM channel model is explained in section 3. Next, the parameters and environments settings are presented in section 4. Section 5 is the discussion of the simulation results. Finally Section 6 is concluding this paper.

2 Background

2.1 VANETs Standard

Dedicated Short Range Communication DSRC is the wireless communication protocol for the Vehicular Ad-hoc Networks, it was approved by the United State Federal Communication Commission FCC in 1992 [4]. DSRC is allocated to support the Intelligent Transport System ITS applications in the licensed band of 5.9 GHz. In 2004, the DSRC joined the IEEE (Institute of Engineering Electrical and Electronics) and classified as a part of the IEEE 802.11 family known as IEEE 802.11p [5]. The IEEE 802.11p standard uses the same physical layer as the IEEE 802.11a standard. However, the only difference is the bandwidth channel which is 10MHz instead of the 20MHz [6]. The purpose of the IEEE 802.11p standard is to provide the minimum specification, ensuring that the devices are able to communicate in rapidly changing environment [7].

2.2 MIMO Technology with VANETs

In VANETs communications the advantages of having unlimited battery life and multiple antennas positions are strong factors in using Multiple-Input-Multiple-Output MIMO systems with VANETs [8]. MIMO systems perform higher capacities compared to single antenna systems. However, there are significant challenges which need to be taken in the consideration like: channel modeling, processing of space time signals in VANETs and channel coding. MIMO provides considerable advantages including having wider coverage area, enhancing the multi fading environments and improving higher data throughputs [9]. Providing high data rate at high QoS in VANETs communication system, is considered as the greatest challenges in this research area [10] [11]. Due to the factors that could affect to the signal strength such as scattering, reflection and interference, the bandwidth is needed to improve the QoS. To improve the bandwidth there are two methods in general [8], in the first approach the diversity technique is used to improve link reliability in term of improving the transmit diversity and/or the receive diversity. The use of higher modulations and efficient codes will increase the data rate which consequently leads to improving the reliability of the link [8]. In the second approach MIMO systems are used in both transmitter and receiver, while each transmitting antenna transmits a separate stream of data. However, MIMO technology seems to meet these issues in term of increasing the inbound and outbound data traffic [12].

2.3 Vertical Bell Labs Layered Space Time V-BLAST.

V-BLAST is non – linear MIMO receiver detection algorithm to the receipt of multi antenna MIMO systems. The principle of this algorithm: V-BLAST employs successive interference cancellation SIC. At the beginning, the algorithm identifies the most powerful signal which has a highest SNR, next step it regenerates the received signal from this user from available decision. The impact of each estimated symbol is cancelled from the received symbol vector so what does SIC roughly means. One symbol is estimates from the vector $\mathbf{x}_1\mathbf{x}_2\mathbf{x}_3\mathbf{x}_4$, for example \mathbf{x}_1 then the impact of \mathbf{x}_1 will be removed from the receive vector \mathbf{y} and the rest of the symbols are decodes similarly. After decoding every symbol the effect of it will be remove progressively in the receive symbol vector and so on to decode the other receive symbol [13].

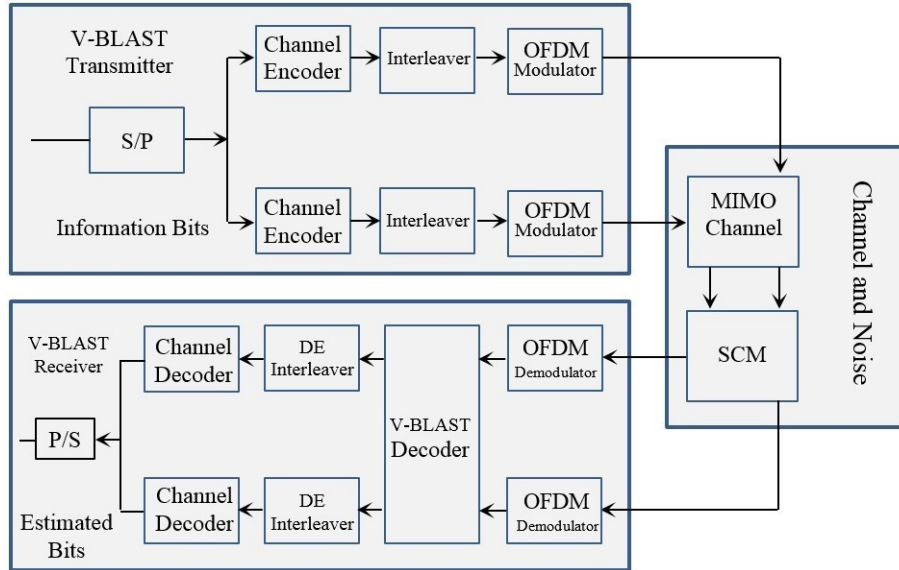

Fig. 1. 2x2 V-BLAST MIMO System

3 Spatial Channel Model SCM

3.1 SCM Overview

The MIMO – SCM was established in 2003 by the Partnership Project standards body, 3GPP [14]. SCM is a wireless propagation channel based on stochastic modelling, or the ray-based model, which is specified to outdoor antennas in terms of mobility. It is commonly used in a dynamic MIMO channel as it can take account of the temporal correlation parameters of the communication channel. However, an SCM is dedicated for a Code Division Multiple Access (CDMA) system with 5MHz band and 2GHz frequency [15]. The 3GPP simulated the SCM-MIMO wireless propagation channel in various cases: urban Macrocell environment, suburban Macrocell environment and urban microcell environment. They apply the concept of spatial and polarization diversity assuming multiple antennas at both the transmitter and receiver [16]. The SCM distributes the positions of the scatters randomly instead of using the direct signal representation in the environment [17]. In V2V communication, the obstacles objects present in the environment (e.g. buildings, trees and vehicles) makes the signals overlap. If the overlapping does not exist, the signal will propagate as a line of sight (LOS) path, or as a non LOS (NLOS) path [18] Figure 2.

3.2 The Proposed Channel Model

The proposed model is built upon the 3GPP model. It mainly follows the approach of the SCM model to utilise it as a V2V channel model. In [4], Rayleigh / AWGN channel model are used as a V2V channel model. However, Rayleigh / AWGN are not representing V2V channel model. The proposed channel model is an amended model of SCM-MIMO. Due to the nature of V2V communication, it is assumed that the AoD and AoA is (180 ± 5) in microcell suburban (1km coverage distance). Equation 1 is the mathematical model of V2V communication which is used to estimate the channel parameters in microcell suburban.



Whereas:

P_n is the power of the n th path.
 N is the number of paths (clusters).
 M is the number of sub-paths per path.
 S is the number of the sender linear array antenna elements.
 R is the number of the receiver linear array antenna elements.
 $\Phi_{n,m}$ is the phase of the m th sub-path of the n th path.
 $\theta_{n,m}$, AoD is the AoD for the m th subpath of the n th path.
 $\theta_{n,m}$, AoA is the AoA for the m th subpath of the n th path.
 V_1 is vehicle1 antenna gains of each array element.
 V_2 is vehicle2 antenna gains of each array element.
 j is the square root of -1. k is the wave number $2\pi / \lambda$, where λ is carrier wavelength in meters. d_s is the distance in meters from the sender antenna elements. d_r is the distance in meters from the receiver antenna elements. v is the magnitude of the sender velocity vector. θ_v is the angle of the sender velocity vector.

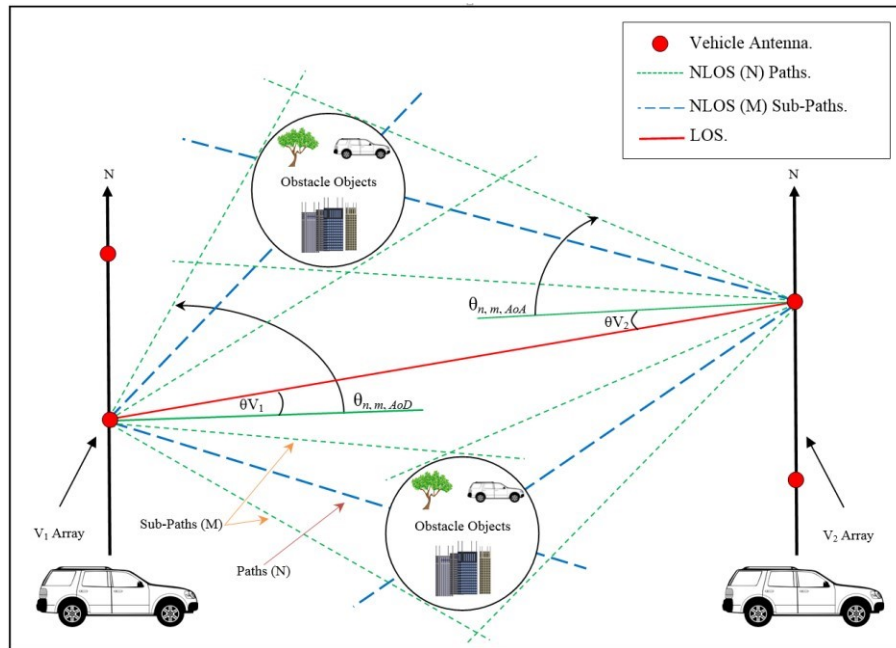

Fig. 2. SCM Modeling Approach in V2V

4 Parameters and Environment Settings

In order to estimate channel fading, channel capacity and the power delay for the V2V communication, three different speeds are considered with three environments at 5.9GHz carrier frequency: Figure 3 for the slow speed (20km/h), Figure 4 for the medium speed (60km/h) and Figure 5 for the high speed (100km/h). The three different environments have been tested according to their disruption levels: low level, medium level and high level disruptions environments. The number of clusters (Multi-path) = 2 and sub-path clusters = 5 allocated for the low level disruption environment while the number of clusters = 4 and sub-path clusters = 10 allocated for the medium level disruption environment and the number of clusters = 6 and sub-path clusters = 20 allocated for the high level disruption environment. In these environments two modulation scheme have been used 4-QAM and 16-QAM.

5 Simulation Results and Discussion

Different Scenarios and tests have been run using SCM-MIMO-2x2 based on the VBLAST coding system in high dynamic disruption environment. In Equ 1, H is the instant channel parameter for 10 sec period in MIMO 2X2 matrix ($h_{11}, h_{12}, h_{21}, h_{22}$) generated by the SCM [3], as it's periodically change over the time to generate new H.

$$Y = HX + N \quad (2)$$

$$\begin{bmatrix} y_1(t) \\ y_2(t) \end{bmatrix} = \begin{bmatrix} h_{11} & h_{12} \\ h_{21} & h_{22} \end{bmatrix} \begin{bmatrix} x_1(t) \\ x_2(t) \end{bmatrix} + \begin{bmatrix} n_1(t) \\ n_2(t) \end{bmatrix} \quad (3)$$

Whereas, x is the transmitted symbol vector. y is the received symbol vector. h is the channel characteristics matrix. n is the noise.

The simulation results in Figures 3, 4 and 5 show the BER vs. SNR for three different speeds (20km/h, 60km/h and 100km/h) and two different modulations 4-QAM and 16QAM. Table 1 compares the SNRs results at BER 10^{-2} considerably and the simulation results seems to be consistent when the V-BLAST coding is used.

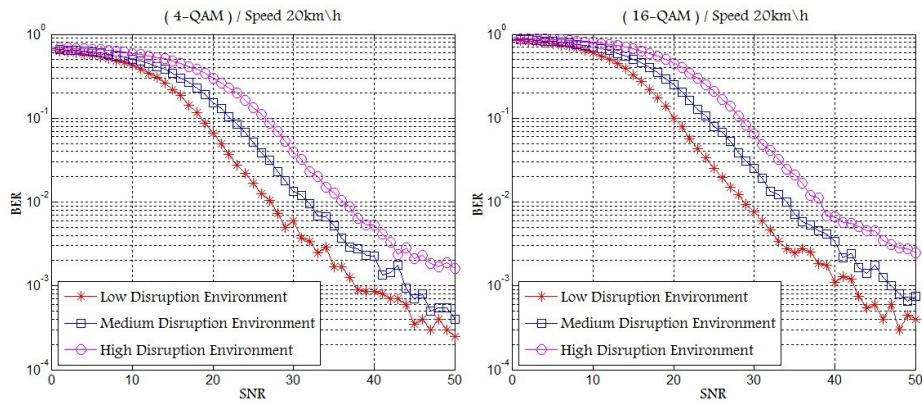

Fig. 3. Vehicle Speed 20 km/h (4-QAM and 16-QAM).

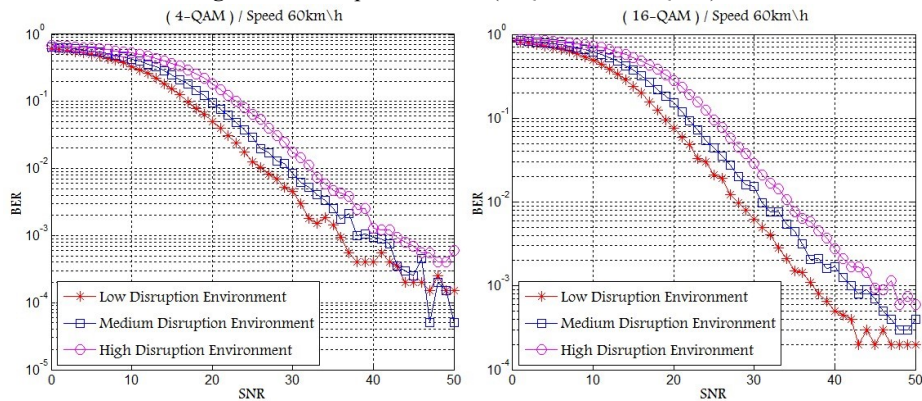

Fig. 4. Vehicle Speed 60 km/h (4-QAM and 16-QAM).

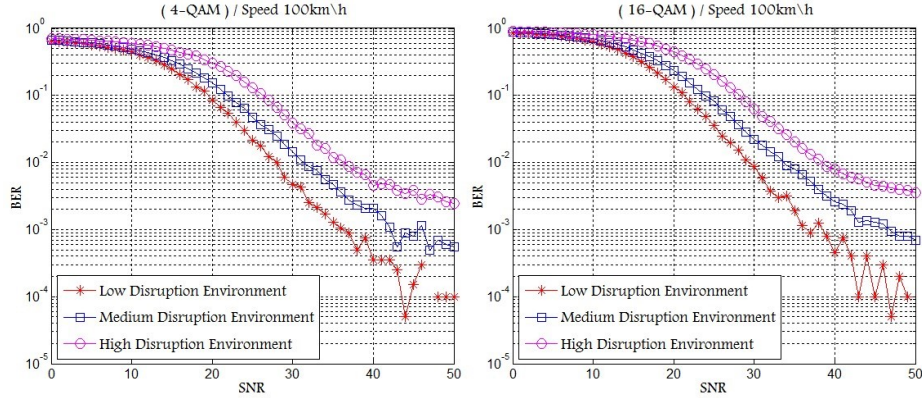

Fig. 5. Vehicle Speed 100 km/h (4-QAM and 16-QAM).

Table 1. The SNRs at BER 10^{-2} Gained from Figures 3, 4 and 5 for 4-QAM and 16-QAM Modulation.

Speeds	Disruption Level Environment					
	<i>Low Disruption</i>		<i>Medium Disruption</i>		<i>High Disruption</i>	
	4QAM	16QAM	4QAM	16QAM	4QAM	16QAM
20km/h	27	29	33	34	37	38
60km/h	26	28	29	31	33	34
100km/h	28	29	32	34	37	38

As shown in table 1, as a vehicle is traveling at slow speed 20km/h the results for the 16-QAM modulation are 29, 34, and 38. These results are considered consistent according to the disruption levels low, medium and high, while comparing with our previous work in [19] the obtained result were 37, 34 and 37 with the same environment settings which are inconsistent. The results in table 1 indicate that the performance of the PHY in V2V communication improves considerably and the simulation results seems to be consistent when the V-BLAST coding is used.

6 Conclusion and Future Work

In this paper, SCM-MIMO channel model with V-BLAST coding system is used to evaluate V2V physical layer performance. The amounts of the considered parameters in SCM-MIMO channel model attempt to mimic the highly dynamic disruption environment in V2V. The channel model with V-BLAST has improved the bit error rate for the nodes moving at different speeds, compared to the previous work [19] with Alamouti coding. On the other hand, the Rayleigh / AWGN channel model has been also used in [4] as a V2V channel model. However, Rayleigh / AWGN are a general channel model and not specifically designed to represent V2V channel model. For higher modulation rate such as 64-QAM, it is recommended to choose a more reliable/robust coding system such as T-BLAST, Spatial Modulation SM and Spatial Multiplexing.

References

1. W. H. Organization, "Global status report on road safety: time for action." WHO Library Cataloguing-in-Publication Data, Geneva, 2009.
2. K. Prasanth, K. Duraiswamy, K. Jayasudha and C. Chandrasekar, "IMPROVED PACKET

FORWARDING APPROACH IN VEHICULAR AD HOC NETWORKS USING RDGR ALGORITHM," International Journal of Next Generation Network (IJNGN), vol. 2, p. 1, 2010.

3. R. Kumar and M. Dave, "A Comparative Study of Various Routing Protocols in VANET," IJCSI International Journal of Computer Science , vol. 8, p. 1, 2011.
4. A. Al-Khalil, A. Al-Sherbaz and S. Turner, "Enhancing the Physical Layer in V2V Communication Using OFDM-MIMO Techniques," in PGNet, Liverpool, 2013.
5. L. Miao, K. Djouani, B. Wyk and Y. Hamam, "Evaluation and Enhancement of IEEE 802.11p Standard: A Survey," Mobile Computing, vol. 1, no. 1, 2012.
6. C. Han, M. Dianati, R. Tafazolli and R. Kernchen, "Throughput Analysis of the IEEE 802.11p Enhanced Distributed Channel Access Function in Vehicular Environment," in IEEE, 2012.
7. IEEE, "IEEE Draft P802.11-REVmb™/D12," Institute of Electrical and Electronics Engineers, New York, 2011.
8. G. Abdalla, Physical and Link Layers of Vehicle Ad Hoc Networks: Investigating the performance of MIMO-OFDM and IEEE 802.11 in VANET, LAP LAMBERT Academic Publishing, 2011.
9. D. Nguyen and J. Garcia-Luna-Aceves, "A Practical Approach to Rate Adaptation for MultiAntenna Systems," in 19th IEEE International Conference on Network Protocols, Vancouver, 2011.
10. Q. Xue and A. Ganz, "Ad hoc QoS on-demand routing (AQOR) in mobile ad hoc networks," 2002.
11. H. Dok, H. Fu, R. Echevarria and H. Weerasi, "Privacy Issues of Vehicular Ad-Hoc Networks," vol. Vol. 3, 2010.
12. H. Bolcskei and E. Zurich, "MIMO-OFDM WIRELESS SYSTEMS: BASICS, PERSPECTIVES, AND CHALLENGES," IEEE, 2006.
13. Y. Wu, X. Peng and Y. Song, "A Symbol-wise Ordered Successive Interference Cancellation Detector for Layered Space-Time Block Codes," International Journal of Digital Content Technology and its Applications, vol. 5, p. 4, 2011.
14. M. Shichuan , . D. Deborah, . S. Hamid and Y. Yaoqing , "An Extension of the 3GPP Spatial Channel Model in outdoor-to-indoor environments," in EuCAP 2009. 3rd European Conference on Antennas and Propagation., EU, 2009.
15. D. S. Baum, . J. Hansen, G. . D. Galdo, M. Milojevic, J. Salo and P. Kyösti, "An Interim Channel Model for Beyond-3G Systems: Extending the 3GPP Spatial Channel Model (SCM)," in Vehicular Technology Conference, 2005. VTC 2005-Spring. 2005 IEEE 61st, 2005.
16. I. Xirouchakis, "www.mathworks.co.uk," MATHWORKS, 31 July 2008. [Online]. Available:<http://www.mathworks.co.uk/matlabcentral/fileexchange/20911-spatial-channelmodel-for-mimo-simulations-a-ray-based-simulator-based-on-3gpp-tr-25-996-v-6-1-0>. [Accessed 02 July 2013].
17. S. Jaeckel, K. Börner, L. Thiele and V. Jungnickel, "A Geometric Polarization Rotation Model for the 3-D Spatial Channel Model," IEEE TRANSACTIONS ON ANTENNAS AND PROPAGATION, vol. 60, no. 12, p. 12, 2012.

18. L. Zhang and . F. Chen, "A Channel Model for VANET Simulation System," International Journal of Automation and Power Engineering (IJAPE), vol. 2, no. 4, p. 7, 2013.
19. A. B. Al-Khalil, S. Turner and A. Al-Sherbaz, "Feasibility Study of Utilising SCM – MIMO Channel Model in V2V Communication," in 7th International Workshop on Communication Technologies for Vehicles, Saint-Petersburg, 2014.