

Kent Academic Repository

Full text document (pdf)

Citation for published version

Podoleanu, Adrian G.H. and Bradu, Adrian and Cernat, Ramona and Marques, M.J. (2020) From master-slave to down-conversion optical coherence tomography. In: *Optical Coherence Tomography and Coherence Domain Optical Methods in Biomedicine XXIV*, 01 Feb - 06 Feb 2020, San Francisco, California, USA.

DOI

Link to record in KAR

<https://kar.kent.ac.uk/80332/>

Document Version

Publisher pdf

Copyright & reuse

Content in the Kent Academic Repository is made available for research purposes. Unless otherwise stated all content is protected by copyright and in the absence of an open licence (eg Creative Commons), permissions for further reuse of content should be sought from the publisher, author or other copyright holder.

Versions of research

The version in the Kent Academic Repository may differ from the final published version.

Users are advised to check <http://kar.kent.ac.uk> for the status of the paper. **Users should always cite the published version of record.**

Enquiries

For any further enquiries regarding the licence status of this document, please contact:

researchsupport@kent.ac.uk

If you believe this document infringes copyright then please contact the KAR admin team with the take-down information provided at <http://kar.kent.ac.uk/contact.html>

PROCEEDINGS OF SPIE

SPIDigitalLibrary.org/conference-proceedings-of-spie

From master-slave to down-conversion optical coherence tomography

Podoleanu, Adrian, Bradu, Adrian, Cernat, Ramona, Marques, Manuel Jorge

Adrian Podoleanu, Adrian Bradu, Ramona Cernat, Manuel Jorge M. Marques, "From master-slave to down-conversion optical coherence tomography," Proc. SPIE 11228, Optical Coherence Tomography and Coherence Domain Optical Methods in Biomedicine XXIV, 1122819 (21 February 2020); doi: 10.1117/12.2548617

SPIE.

Event: SPIE BiOS, 2020, San Francisco, California, United States

From Master-Slave to Down-conversion Optical Coherence Tomography

Adrian Podoleanu^a, Adrian Bradu^a, Ramona Cernat^a, and Manuel J. Marques^a

^aApplied Optics Group, School of Physical Sciences,
University of Kent, Canterbury CT2 7NH, United Kingdom.

ABSTRACT

We present here advances on the Master Slave (MS) concept, applicable to spectral/Fourier/frequency-domain optical coherence tomography (OCT) technology. Instead of obtaining an A-scan from the sample investigated via a Fourier Transform (FT) or equivalent, the amplitude of the A-scan for each resolvable point along the depth is obtained along a separate output. A multiplier produces the product of the photo-detected signal from the OCT system with that generated by an Electrical or an Optical Master. This allows acquisition at a frequency comparable to that of the sweeping, much inferior to the frequency bandwidth of the channeled spectrum. 3 advantages of the down-conversion method are demonstrated here: (a) real time delivery of an *en-face* image; (b) axial optical path difference (OPD) range at the level of the source's dynamic coherence length and (c): tolerance to fluctuations in the sweep of the swept source. The most important advantage of the down-conversion method is that it reduces the signal bandwidth considerably, to the level of the sweeping rate. This facilitates real-time operation. Conventional A-scan production can only be performed real-time if the FT processing is carried out in a time comparable to or less than the sweep time, which depending on the number of sampled points and dynamic range determines a limit of \sim MHz sweep rate. Before even calculating a FT, acquisition may also be limited by the sampling rate of the digitiser. In conventional SS-OCT, the number of depth points can exceed 1,000, which for a sweeping time of $1\ \mu\text{s}$ would determine signals in the GHz range. Using long coherence length swept sources, this number of depths could be even larger, hence the conventional FT-based method faces a bottleneck due to the time needed to calculate the FT, combined with the need to acquire data at many GS/s.

Keywords: master-slave optical coherence tomography, down-conversion method, swept-source optical coherence tomography, *en-face* imaging, spectral sampling, Fourier transform

Master Slave (MS) OCT method was introduced to address the problems raised by using a Fourier Transform (FT) in processing the signal at the interferometer output, generated by either a spectrometer or a photodetector (as conventionally performed in swept source (SS) OCT), according to Fig. 1(a). This signal has encoded in its frequencies the different depth-distributed features in the object.

In the initial report¹ introducing the MS operation, an interrogating interferometer (Master) was employed, and a comparison operator of the electrical signals delivered by the spectrometers or photo-detectors at the outputs of the imaging (Slave) and interrogating (Master) interferometers, as shown in Fig. 1(b). Both Master and Slave interferometers are driven by the same swept source. In what follows we refer to the method in Fig. 1(b) as the D-method. The MS method was evolved to a more practical procedure, as illustrated in Fig. 1(c), where the interrogating (Master) interferometer was replaced by the same imaging interferometer employed sequentially in two steps, Master and Slave. At the Master stage, a mirror is employed as sample and channeled spectra acquired for several OPD values are stored as masks. They are subsequently used as masks (Electrical Masters) at the Slave step, when the sample replaces the mirror, and the masks are then compared with the acquired channeled spectra (CS) from the object. In this way we have shown that it is possible to: (i) directly access the information from selected depths, allowing direct rendering of *en-face* OCT images; (ii) eliminate the process of resampling, required by the FT based conventional technology, with immediate consequences in improving the decay of sensitivity with depth, in achieving the expected axial resolution limit, lowering the cost of OCT assembly; (iii) tolerate the dispersion left unbalanced in the OCT interferometer. Later, we introduced the Complex Master Slave (CMS) method, where from a few measurements (a minimum of two), any number of masks can be obtained.

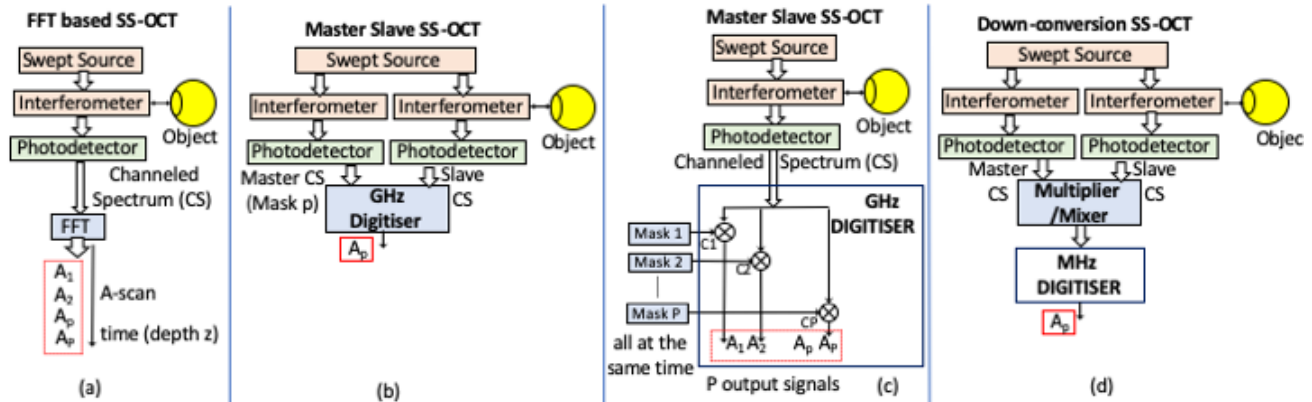

Figure 1. Evolution of the Master Slave OCT technology. (a): Conventional FFT based processing; (b): Basic concept of MS implementation, **Digitiser (D) method**; (c): Complex Master Slave using a single interferometer at two stages, providing equivalent information as the FFT based method, with the same level of detail, i.e. all points A_1, A_2, \dots, A_P , **CMS method**; (d): Down-conversion, using a mixer (**M**)-method.

The comparison operation was performed digitally, via cross-correlations or matrix multiplications.² The comparison operation in Fig. 1(b) and Fig. 1(c) handles signals in the hundreds of MHz and GHz range and requires digitizers capable of sampling rates in the hundreds of MHz to several GHz. If, instead of performing the comparison operation in the band of the channeled spectrum modulation, the signals are multiplied and the results are low pass filtered, a down-conversion operation is performed as shown in Fig. 1(d). In Ref.³ we have demonstrated the down-conversion using double-balanced RF mixers. One input of the mixer was fed by the photodetector in the Slave interferometer and the other by the photodetector in the Master interferometer (Optical Master). In what follows, we refer to the configuration in Fig. 1(d) as the M-method implementation.

Selection of depth in the object at which an *en-face* image is produced in Fig. 1(b) is performed via the OPD change in the separate, physical interferometer. A Master interferometer would be needed for each of the depth $p = 1, 2, \dots, P$ needed to re-obtain the A-scan otherwise obtained via conventional OCT FFT based technology, where a single Fourier transform of the CS yields all the depths simultaneously. Therefore, the MS technology was progressed towards the implementation in Fig. 1(c), where the Master signals (Masks) are provided by Electrical Masters, i.e. by P stored versions of the CS for the OPD values of interest. The procedure in Fig. 1(c) is that we are continuously progressing the MS technology to for deliver 3D volume data equivalent to the output of the configuration in Fig. 1(a). However, the digitizer in all Fig. 1(a), (b) and (c) operates at CS frequencies that could exceed GHz, either due to high sweeping rates or due to large coherence length of the swept source used, or both. In case the CS bandwidth extends to several GHz, then fast digitizers and oscilloscopes are used to store data making the real time display impossible. To address this bottleneck, in Fig. 1(d), the comparison part of the optoelectronic processor implementing the MS comparison operates as a down-converter, which brings advantages in terms of processing speed and cost. Such a solution can be used to provide one, or several *en-face* images, in case more interferometers are used.

Considering that the maximum frequency in the channeled spectrum is F_{\max} and the maximum frequency to produce an image f_{im} , the down-conversion factor is $\text{DCO} = F_{\max}/f_{\text{im}}$. Normally, to reduce noise in the final image, the imaging bandwidth is restricted to that allowing sufficient time to display each pixel, which is equal to the sweeping time. Let us consider the 200 kHz Axsun source at 1060 nm, that sweeps in $5 \mu\text{s}$, with a duty cycle of $\eta \sim 60\%$, i.e. the useful spectrum is tuned within $1/(\eta F_S) = 3 \mu\text{s}$, where $F_S/\eta = F'_S$ defines an equivalent sweeping frequency. This gives $F_S = 333 \text{ kHz}$, so the digitizer would need to sample at least 666 kHz, and $f_{\text{im}} = F_S$.

The number of resolvable points in depth is obtained by AR/ARI , where AR is the axial range and ARI the axial resolution interval. $\text{AR} = 0.25\lambda^2/\delta\lambda = b\lambda^2/\delta\lambda$. $\text{ARI} = a\lambda^2/\Delta\lambda$, where a for a Gaussian spectrum is $a = 2 \ln 2/\pi$ and for a top hat spectrum, typical for a swept source, $a = 0.5$. So, $\text{AR}/\text{ARI} = (b/a)\Delta\lambda/\delta\lambda$. This also corresponds to the approximate number of cycles in the channelled spectrum. The maximum frequency in the photo-detected spectrum becomes: $F_{\max} = F_S \times \text{AR}/\text{ARI}$. This means that the down-conversion factor

$DCo = F_{max}/f_{im} = AR/ARI$. This ratio determines how much larger the frequency of the photo-detected signal is in respect to the equivalent sweeping rate. In other words, using the M-method, the signal to be processed has a frequency that is DCo times smaller than the frequency of the signal handled by conventional OCT technology.

In the M case, the digitizer processing the signals from the Down-converter needs to digitize signals at a frequency proportional to the inverse time of equivalent sweeping, $1/F_S$. For the 200 kHz swept source used, sufficient strong interference signal could be obtained from an $OPD = AR \sim 3$ cm, where the RF spectrum of the photo-detected signal extends to over 1.1 GHz. Using a value of $ARI \sim 13 \mu\text{m}$ experimentally measured at FWHM, gives a $DCo \sim 2 \times 10^3$. A similar value for the DCo is obtainable by dividing the respective RF value corresponding to an OPD reaching the AR, to the F_S . However, if a swept source similar to that reported in Ref.⁴ was to be used, with over 200 m extra-long coherence length, a $DCo > 10^7$ could be achieved.

This presents an immediate gain in terms of digitizer cost. The extra components needed are a balanced photodetector unit, two couplers and a mixer or an I&Q demodulator, in total costing much less than the cost of a fast digitizer such as from AlazarTech or National Instruments, whose cost can approach or exceed \$10K.

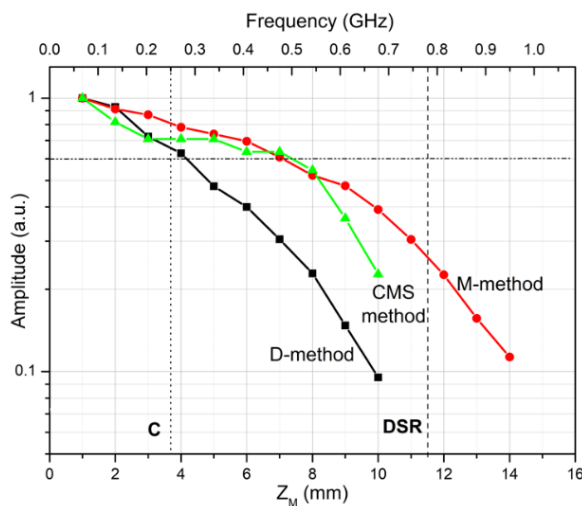

Figure 2. Signal amplitude versus $OPD/2 = z_M$ using the M-method with the Broadband Mixer, D-Method and the CMS-method.

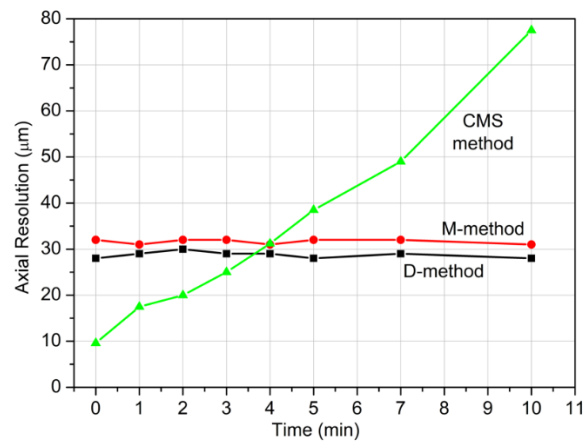

Figure 3. Temporal evolution of the axial resolution for the CMS, D and M-method using a broadband mixer over 10 minutes after the swept source was switched on. The data was evaluated for $Z_M = 3$ mm.

In terms of axial range, the down-conversion eliminates the limitation imposed by the sampling rate of the digitizer. The sensitivity curves versus OPD obtained for the set-ups in Fig. 1(d) (Mixer method -M), in Fig. 1(b) (Digitiser method - D using Alazar) and in Fig. 1(c) (CMS method, using the Alazar) are shown in Fig. 2. There is an expected decay of sensitivity with OPD, as the larger the OPD, the shorter the overlap of the two wave-train lengths corresponding to the two interfering waves. The wave-train length is inversely proportional to the linewidth of the dynamic spectral emission of the swept source. For this reasons, SS-OCT sensitivity decays with depth in the M-method. Extra decay in the other two curves is caused by the limited sampling rate of the digitizer, with an added decay for the D-method where the comparison is implemented with experimentally collected masks, making it sensitive to variations in the spectrum envelope (eliminated in the CMS implementation). Not only that the decay for the M-method is less than in the other two methods, but significant signal is obtained beyond the limits established by conventional technology. A first constraint for the CMS method is imposed by the clock signal pulsating at 500 MHz (in this case, the clock is delivered by the Axsun source). This limits the axial range to the OPD value which creates a modulation of 250 MHz, according to Nyquist's theorem, as shown by the vertical dotted line at 3.67 mm depth, marked as C (Fig. 2). A second limit is that of the digital sampling rate (DSR) of the digitizer. At the maximum sampling frequency (1.8 GS/s), experimentally, using FFT, we noticed a reversal of the A-scan peak at a frequency measured by the RF spectrum analyzer ~ 780 MHz, shown by the DSR vertical dashed line placed slightly above 11 mm. The M-method is functional well above this second limit, reaching over 14 mm in depth.

Fig. 3 shows the variation of the axial resolution in time using the CMS, D and M-methods for a given OPD value. The CMS requires calculation of masks that depends on the stability of the phase. In this respect, the CMS method suffers exactly as the conventional software method based on FFT (when k -domain linearization and dispersion compensation procedures are applied prior to the FFT), due to the need to perform calibrations more often. It should be noted that these variations are specific to the source used in this study, and we have no data indicating whether other Axsun sources with a 200 kHz sweep rate exhibit the same behavior. For the particular source used, the achievable axial resolution varies wildly within the 10 minutes after powering up the swept source. We used this behaviour to demonstrate the applicability of the down-conversion method in tolerating such instabilities. Effectively, the D-method (Fast digitizer) and M-method (Low speed digitizer) exhibited constant values for the axial resolution, i.e. the mixing method with masks created in real time by a Master interferometer tolerates instabilities in the tuning curve of the swept source. If data would have been collected for a longer time, the CMS axial resolution would have recovered and then deteriorated again (not shown). This behavior is eliminated in the conventional SS-OCT and CMS-OCT if the clock from the swept source was used. The slightly worse axial resolution of the D and M-methods in Fig. 3 is due to the two interferometers not being perfectly matched in terms of dispersion.

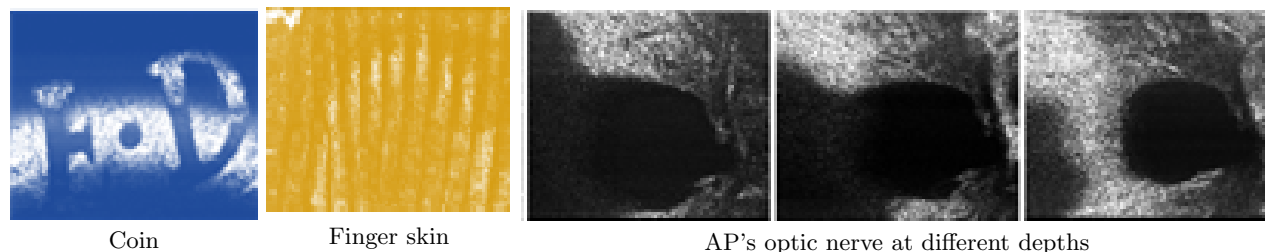

Figure 4. 200x200-pixel images ($\sim 2\text{ mm} \times 2\text{ mm}$) delivered by down-conversion using a single Master interferometer for the signal delivered by the OCT interferometer.

Images will be presented obtained with the Down-conversion (M-method). Here in Fig. 4 we show several such *en-face* OCT images obtained so far. Work is in progress to add more Master interferometers and demonstrate the concept on much faster swept sources.

ACKNOWLEDGEMENTS

A. Podoleanu, A. Bradu and M. J. Marques are supported by the Biotechnology and Biological Sciences Research Council (BBSRC) (*5DHiResE*, BB/S016643/1) and the Engineering and Physical Sciences Research Council (EPSRC) (*REBOT*, EP/N019229/1). A. Podoleanu and R. Cernat acknowledge the support of National Institute for Health Research (NIHR) Biomedical Research Centre at UCL Institute of Ophthalmology, University College London and Moorfields Eye Hospital NHS Foundation Trust. A. Podoleanu also acknowledges the Royal Society Wolfson research merit award.

REFERENCES

- [1] Podoleanu, A. G. and Bradu, A., "Masterslave interferometry for parallel spectral domain interferometry sensing and versatile 3D optical coherence tomography," *Optics Express* **21**, 19324 (Aug. 2013).
- [2] Bradu, A., Rivet, S., and Podoleanu, A., "Master/slave interferometry ideal tool for coherence revival swept source optical coherence tomography," *Biomedical Optics Express* **7**, 2453 (July 2016).
- [3] Podoleanu, A., Cernat, R., and Bradu, A., "Down-conversion *en-face* optical coherence tomography," *Biomedical Optics Express* **10**, 772 (Feb. 2019).
- [4] John, D. D., Burgner, C. B., Potsaid, B., Robertson, M. E., Lee, B. K., Choi, W. J., Cable, A. E., Fujimoto, J. G., and Jayaraman, V., "Wideband Electrically Pumped 1050-nm MEMS-Tunable VCSEL for Ophthalmic Imaging," *Journal of Lightwave Technology* **33**, 3461–3468 (Aug. 2015).