

NEGATIVE GRID VALVES AND THEIR CIRCUITS

FOR DECIMETRE WAVES

by

M.R. GAVIN, M.A., B.Sc.

THESIS SUBMITTED TO THE UNIVERSITY

OF GLASGOW

MAY 1949

ProQuest Number: 13870181

All rights reserved

INFORMATION TO ALL USERS

The quality of this reproduction is dependent upon the quality of the copy submitted.

In the unlikely event that the author did not send a complete manuscript and there are missing pages, these will be noted. Also, if material had to be removed, a note will indicate the deletion.



ProQuest 13870181

Published by ProQuest LLC (2019). Copyright of the Dissertation is held by the Author.

All rights reserved.

This work is protected against unauthorized copying under Title 17, United States Code  
Microform Edition © ProQuest LLC.

ProQuest LLC.  
789 East Eisenhower Parkway  
P.O. Box 1346  
Ann Arbor, MI 48106 – 1346

## CONTENTS

	<u>Page</u>
<u>Preface.</u>	1
<u>Part I.</u>	5
1. Historical Introduction	6
<u>Part II. Oscillators.</u>	10
2. Circuits for Triode Oscillators.	11
2,i. The Hartley and Colpitts Circuits at Very High Frequencies.	11
2,ii. The Oscillatory Circuit.	14
2,iii. The 'Micropup'.	18
2,iii,a. The Basic Micropup Circuit.	23
2,iv. The 10 cm. Triode.	25
2,v. Receiving Valves.	28
2,v,a. Common-Anode Valves.	28
2,v,b. Common-Grid Valves.	28
3. Excitation of Triode Oscillators.	32
3,i. Simple Considerations.	32
3,ii. More Exact Analysis of Excitation.	35
3,ii,a. Relative Merits of Two Classes of Oscillator.	36
3,ii,b. Multiple Quarter Wave Circuits.	39
4. Push-Pull and Multivalve Circuits.	40
<u>Part III. Amplifiers.</u>	44
5. Amplifiers.	45
5,i. Common-Grid Amplifiers.	45
5,ii. Everted Triodes and Tetrodes.	48

Contd.

CONTENTS (Contd.)

	<u>Page</u>
<u>Part IV. U.H.F. Electronics.</u>	
6. U.H.F. Electronics.	52
6,i. Introduction.	52
6,ii. Electron Pump Effect.	55
6,iii. General Transit Time Effects.	60
6,iv. Onset of Transit Time Effects.	64
6,v. Minimum Wavelength set by Electron Transit Time.	74
6,vi. Cathode Emission.	78
<u>Part V. Summary and Conclusion.</u>	
7. 7,i. Conclusion.	81
<u>References.</u>	85
<u>Appendices.</u>	89
A. Electron Pump Effect at High Frequencies.	
B. Triode Oscillators for Ultra-Short Wavelengths.	
C. Negative-Grid Valves for Ultra-High Frequencies.	
D. V.H.F. Valves and Circuits.	
E. Everted Triodes and Tetrodes.	
F. Push-Pull Circuits.	
G. Multivalve Circuits.	
H. Triodes for Very Short Waves - Oscillators.	
J. Deflected Beam Valves for Ultra-High Frequencies.	

Contd.

## LIST OF ILLUSTRATIONS

<u>Figure</u>		<u>Facing Page</u>
1.	Valves for Decimetre Wavelengths.	1
2.	Hartley Circuit at Low Frequencies.	11
3.	Colpitts Circuit at Low Frequencies.	11
4.	Hartley Circuit at High Frequencies.	11
5.	Triode with Transmission Line Circuit.	14
6.	Oscillatory Circuits for a Wavelength of 90 cm. with E1029 and DET12.	15
7.	Common-anode earthed-anode Oscillator as used with the Micropup and its family.	18
8.	Sectional view of the NT99 Triode.	20
9.	E1274, 10 cm. Triode.	25
10.	Common-grid earthed-anode Circuit used with E1274 Triode.	26
11.	Common-grid earthed-grid Oscillator ('Grounded-grid' Circuit).	28
12.	Common-grid earthed-anode Oscillator using CV90 Triode.	29
13.	Common-grid earthed-cathode Oscillator using 'lighthouse' Triode.	30
14.	Common-anode Circuit.	32
15.	Common-grid Circuit.	32
16.	Common-anode Circuit.	33
17.	Triode Circuit.	35
18.	Class I Oscillator.	37
19.	Class II Oscillator.	37
20.	Common-cathode earthed-cathode Circuit using an everted Triode.	38
21.	Push-pull Oscillator with two E1029 Triodes in a Half-wave Concentric Line Resonator.	40
22.	Common-anode earthed-anode Push-pull Oscillator with U-shaped Resonator.	41
23.	Common-anode earthed-anode Push-pull Circuit with U-shaped Concentric Line Resonator and two E1130 Triodes.	41
24.	Common-anode earthed-anode Push-pull Oscillator with quarter-wave parallel Wire Resonator.	42

Contd.

LIST OF ILLUSTRATIONS

(Contd.)

<u>Figure.</u>		<u>Facing Page</u>
25.	Common-anode earthed-anode Push-pull Oscillator with open-ended half-wave Resonator.	42
26.	Common-anode earthed-anode Push-pull Oscillator for a wavelength of 60 cm., using two C55 Triodes.	42
27.	Four-valve Parallel Push-pull Oscillator with four CV55 Triodes.	42
28.	Diagram showing the principle of the everted tetrode and its circuit, for use as a U.H.F. Amplifier.	48
29.	(a) Everted Tetrode.	
	(b) Enlarged cross-sectional view of (a).	49
30.	Circuit used for investigating the electron pump effect.	55
31.	Electron paths in the grid-anode space. $\omega t$ is phased with the grid voltage, which is shown above.	58
32.	The anode current pulse in a Class C Oscillator or Amplifier. The full and broken lines show the pulse shape at L.F. and H.F. respectively.	63
33.	Effect of the Transit Time on the Anode Current and the Anode Dissipation in a Class C Oscillator.	64



P R E F A C E

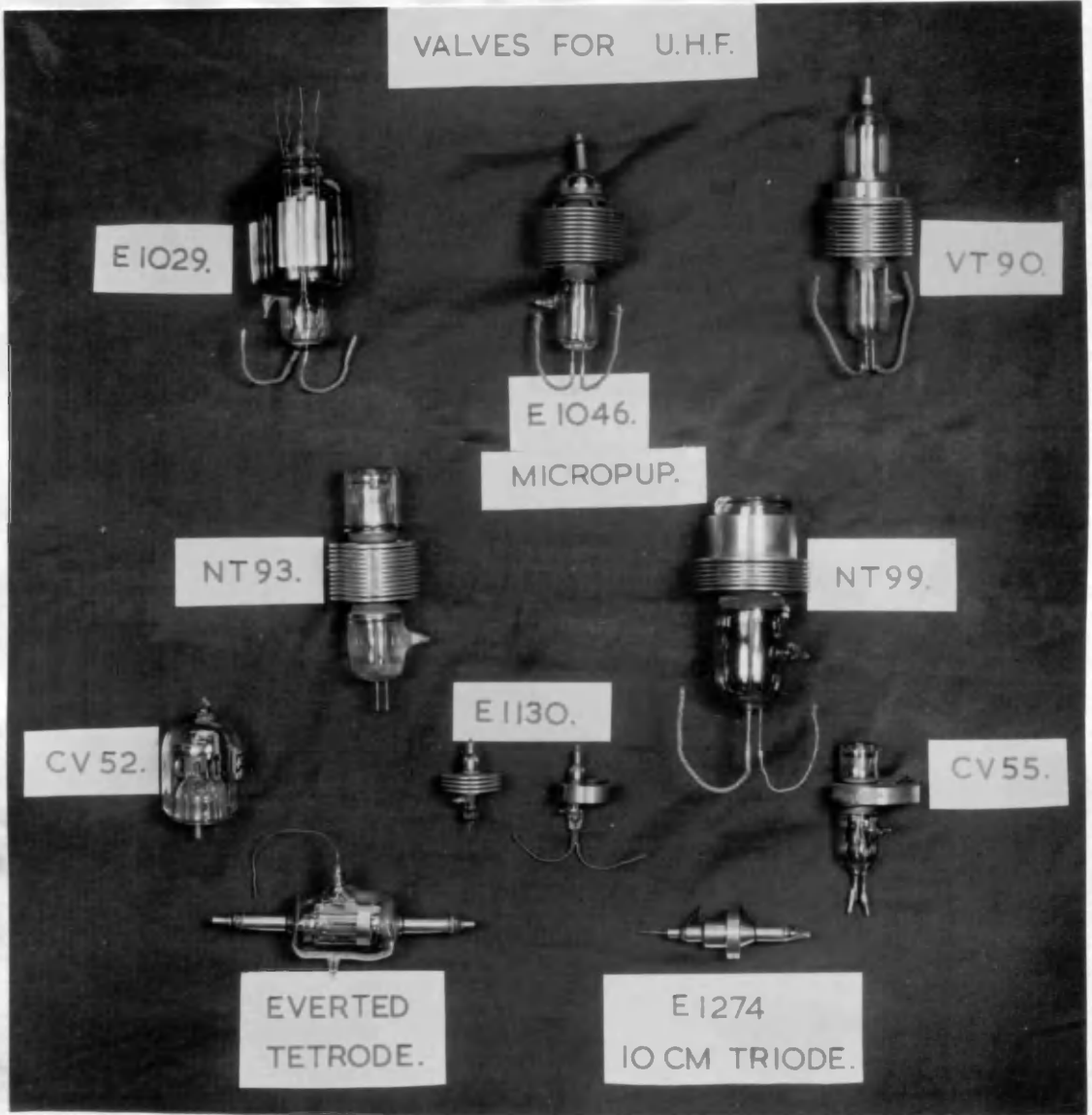

Fig.1. Valves for Decimetre Wavelengths.



PREFACE

This thesis describes the work which was done by the author in the Research Laboratories of The General Electric Co., Ltd., Wembley, on the development of negative-grid valves for wavelengths below 1 metre. Free publication of the results was not allowed during the war and the writing of the thesis was delayed until most of the work had appeared in technical journals. Much of the subject matter of the thesis is now well known as it was used extensively during the war but it will be seen from the dates of the earlier papers and patent specifications that the author's original work was done between 1936 and 1942.

The thesis is divided into four main parts - I Historical Introduction, II Oscillators, III Amplifiers and IV U.H.F. Electronics.

Practically all the main advances in negative grid valves were achieved by developments on the circuit side. By eliminating the uncontrollable sources of coupling which were present in conventional valves and circuits, and by making valves integral parts of the circuits, the 10 centimetre triode was

was ultimately achieved. In addition, the researches produced practically all of the triode generators which were used during the war in decimetre wave radar transmitters. Peak powers of 200 kw at 50 cm and 30 kw at 25 cm were obtained.

Theoretical investigations were made on the fundamental principles of triode oscillator circuits with particular reference to the new types of valves and circuits. As a result of this, the decimetre wave circuits are better understood than many arrangements using conventional valves at longer wavelengths.

These circuit developments are dealt with in Parts II and III.

For negative grid operation the effects of the electron inertia are usually harmful. It is shown in Part IV that these effects impose a fundamental limitation on this mode of operation and that the present wavelength limit around 10 cm. is not likely to be extended much further. The author's investigations into electron inertia effects were aimed, in the first place, at gaining an understanding of their

their nature and, secondly, at establishing data which could be used in valve design.

All the work described in this thesis, with the exception of those items which are clearly indicated in the text, was carried out by the author. In the development of the new valves use was made of mechanics, glass blowers and designers, for the mechanical details of the construction. The basic principles of the valves and circuits were entirely the responsibility of the author.

The photograph in Fig.1 shows some of the valves.

The author's published papers are given as Appendices to the thesis. One of these, Appendix H, is a joint paper with Messrs. Bell, James and Warren, colleagues of the author when he was with the General Electric Co. Much of the material described in that paper was not the author's responsibility but it is included as it supplements the work of the thesis. It also describes some of the later developments on common grid triodes and it gives full constructional details of some of the valves. The author's own

4.

own work has been published in his own name and it is given in the other appendices.

P A R T   O N E

Historical   Introduction

## 1. HISTORICAL INTRODUCTION

Since the earliest days of thermionic valves considerable effort has been devoted to extending the range of operation to higher frequencies. In the early nineteen thirties rapid progress was made, mainly in America, with negative grid valves. When the present work started in 1936 many people thought that the conventional triode oscillator had nearly reached its limit. At that time the 'Acorn' triode (Ref.1.), giving a few milliwatts of output at a wavelength of 35 cm, represented the limit of performance. The 'door-knob' construction of Samuel (Ref.2.) was capable of giving a watt or two of power at 45 cm. and the DET 12 type (Ref.3.), which had also originated in the U.S.A., was used down to 1 metre wavelength with about 10 watts of useful output. With high voltage pulse modulation a pair of door-knobs gave a peak power of 500 watts at 50 cm.

Two main limitations to performance were recognised. These were electronic and circuit limitations.

The time of flight of the electrons between the electrodes became an appreciable fraction of the alternating period when the frequency was sufficiently high. This involved a phase displacement between the electron current in the valve and the electrode voltages, and upset the normal low frequency valve-circuit relationships.

Also, the inter-electrode capacitances and the inductances of the electrode leads set a limit to the maximum frequency. As the external circuit was reduced to raise the operating frequency, a greater proportion of the oscillatory circuit was inside the valve and a limit was reached when no external circuit was left.

In addition to these two factors there were also the increased resistive and dielectric losses of the valve and circuit materials at the higher frequencies.

In order to reduce the effects of the electron transit time the clearances between the electrodes were reduced. (The use of higher voltages was no real solution as they involved excessive heat dissipation).

Unfortunately the reduction in clearances resulted in increased inter-electrode capacitances and to offset this the area of the electrodes was reduced. In addition the overall size of the valves was reduced to cut down the inductance of the leads. These were the methods successfully employed in the acorns and door-knobs. The valves were difficult to make and the size and construction imposed severe limitations on power output. In the acorn and the DET 12 the limit of oscillation was determined by the circuit. In the door-knob there was still some external circuit available when oscillation ceased, but it was not known whether transit time effects or circuit losses were the cause of failure.

It was at this stage in 1936 that the author started on a line of work which eliminated to a large extent the circuit limitation. The advent of radar with pulsed modulation permitted high voltages without excessive dissipation, and so the transit time limitation was overcome, at least for that application. As a result triodes giving peak powers per valve of



of 100 kw at 50 cm. and 15 kw at 25 cm. were realised. At the same time the improved circuits enabled valves to be used on continuous operation right up to the transit time limitation, which proved to be at higher frequencies than was originally believed. And so the 10 cm. triode for C.W. operation was achieved.

It would appear again that a limit has been reached for this type of valve and there seems to be more justification for this conclusion now than there was in 1936.

P A R T    I I

Oscillators

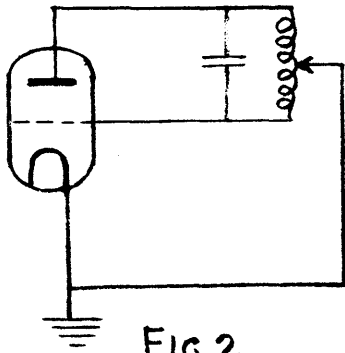

FIG. 2.

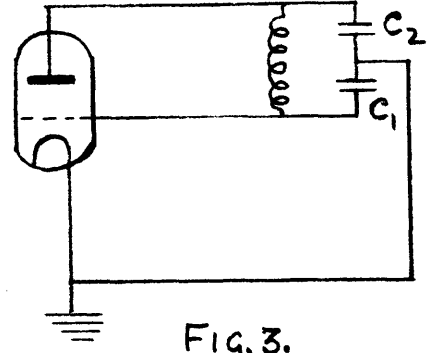

FIG. 3.

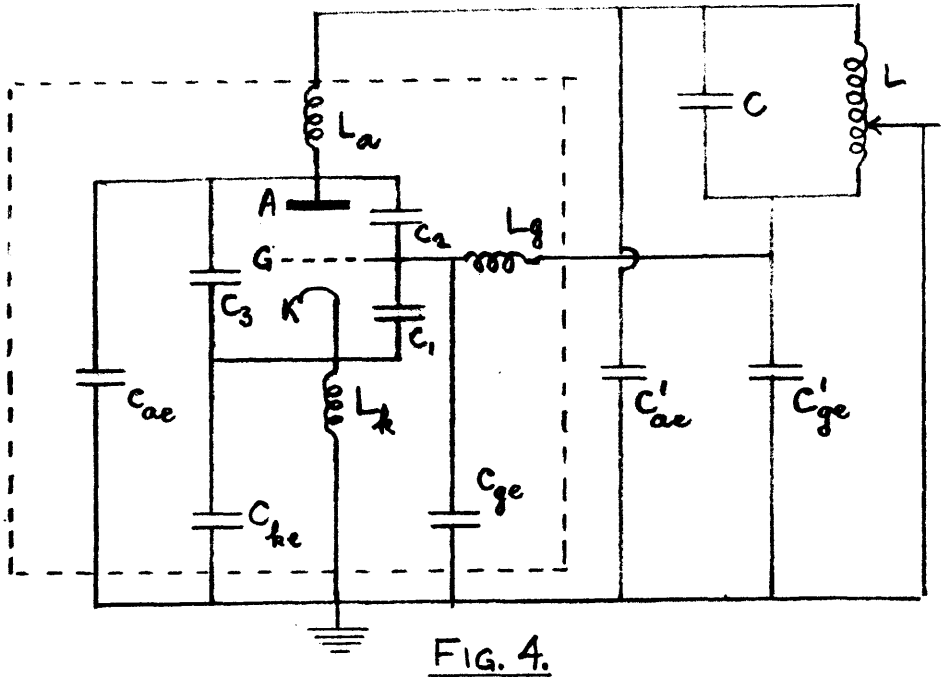

FIG. 4.

Fig.2. Hartley Circuit at Low Frequencies.

Fig.3. Colpitts Circuit at Low Frequencies.

Fig.4. Hartley Circuit at High Frequencies.

## 2. CIRCUITS FOR TRIODE OSCILLATORS

### 2.1 THE HARTLEY AND COLPITTS CIRCUITS AT VERY HIGH FREQUENCIES

Before describing the new technique employed in valves and circuits at V.H.F., it is worth considering the types of circuit commonly used with triode oscillators in the nineteen thirties and some of the reasons for their failure. Versions of the Hartley and Colpitts oscillators were both used. Fig.2. shows the essential Radio Frequency portions of a Hartley oscillator as used at low frequencies. The cathode is earthed and the oscillatory circuit is connected between the anode and the grid. A tapping point on the inductance is joined to the cathode and the excitation of the oscillator is adjusted by moving the tapping point along the inductance. Fig.3. shows the L.F. Colpitts circuit. In this case the ratio of  $C_1$  to  $C_2$  controls the excitation.

At higher frequencies account must be taken of the valve capacitances, the electrode lead inductances and stray capacitances. The simple circuit of Fig.2. then takes the form shown in Fig.4. The portion

portion inside the dotted lines represents the contribution of the valve. The cathode may no longer be connected directly to earth on account of the inductance of its lead, and now the capacitances of the electrodes to earth,  $C_{ke}$ ,  $C_{ge}$  and  $C_{ae}$  must be included. In addition the capacitances to earth of the oscillatory circuit are represented by  $C_{ge}^1$  and  $C_{ae}^1$ . This circuit is extremely complicated and yet, as shown, it is simpler than the actual oscillators that were frequently used. It is not surprising that the behaviour of such a circuit was unpredictable and frequently strange expedients were adopted to improve performance. Chokes were often inserted between the cathode and earth, and fine adjustment of their size would sometimes affect the oscillator considerably. Again, the attachment of a metallic 'flag' to one or other end of the tuned circuit made, on occasion, a great difference to the operation.

The inductance of the cathode lead, which prevents the cathode from being earthed, is one of the main causes of the complication of Fig.4. If it were reduced to zero then most of the earth

earth capacitances could be lumped with the inter-electrode capacitances and the circuit would be much simplified. There is, however, a fundamental limitation to elimination of the cathode lead inductance. The cathode must operate at a temperature of  $700^{\circ}\text{C}$  or more, but the lead through the glass envelope must not exceed about  $200^{\circ}\text{C}$ . To maintain this temperature drop there must be appreciable length of lead.

The circuits of Figs. 2 and 3 have earthed cathodes but they will work equally well with any other point of the system at earth potential. Now, there is no fundamental limitation to the reduction of the anode or grid leads, and most of the modern triode oscillators have earthed anodes or earthed grids with little or no inductance between the relevant electrode and earth.

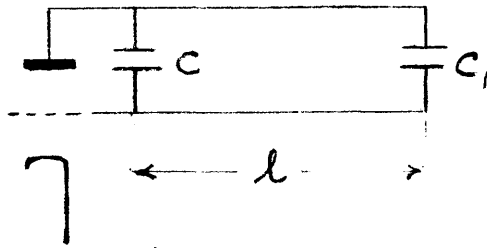

Fig.5. Triode with transmission line circuit.

2,ii. THE OSCILLATORY CIRCUIT.

At the highest frequencies the oscillatory circuit used in oscillators with acorns, door-knobs, etc. usually comprised a short length of parallel wire transmission line acting as the inductance and tuned to resonance by the inter-electrode capacitances. If stray capacitances be neglected then the circuit may be drawn as shown in Fig.5., where C represents the valve capacitances, and the transmission line of length  $l$  is short circuited at the end remote from the valve by the large condenser  $C_1$ . At resonance the reactance of C is equal to the inductive reactance of the line and

$$\frac{1}{\omega C} = Z_0 \tan \frac{2\pi l}{\lambda}$$

where  $\omega = 2\pi f$  = angular frequency

$\lambda$  = wavelength

and  $Z_0$  = characteristic impedance of the line.

This equation may be written as



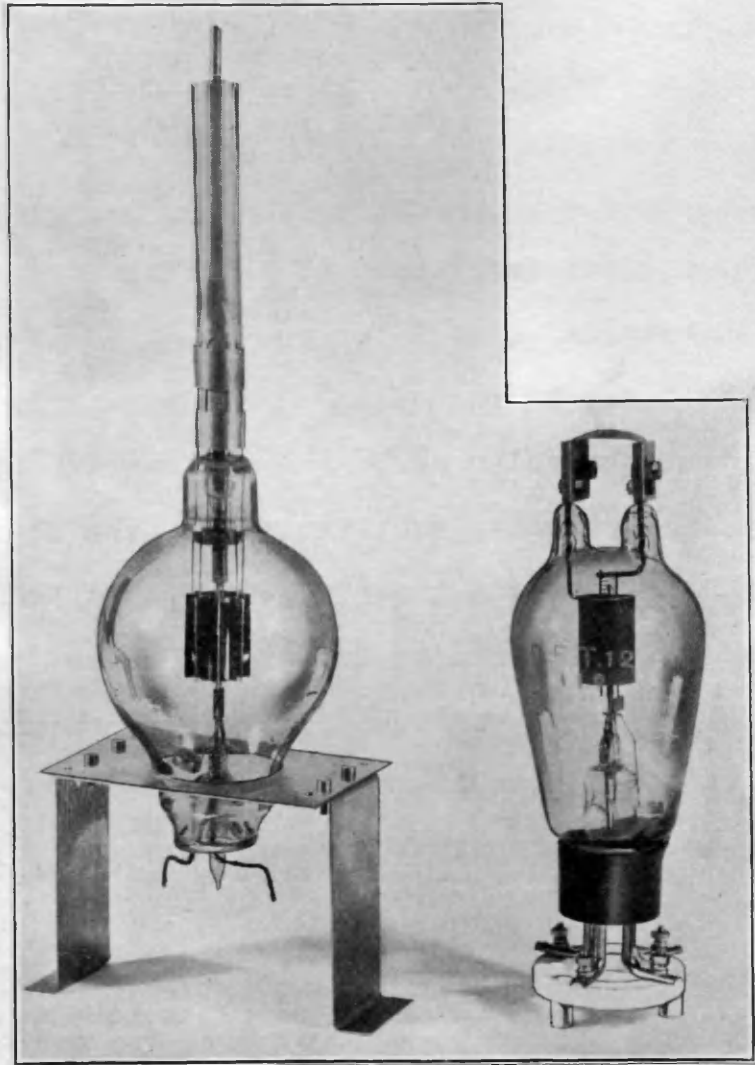

Fig.6. Oscillatory Circuits for a Wavelength  
of 90 cm. with E1029 and DET12.

$$\tan \frac{2\pi l}{\lambda} = \frac{\lambda}{6\pi \times 10^{10} \times c Z_0} \text{-----(1)}$$

For a given wavelength it is desirable to have as large an external circuit as possible. The only quantity which may be varied is  $Z_0$  and it can be seen that the lower the value of  $Z_0$ , the greater the length of the external circuit, and, therefore, the shorter the minimum wavelength for a given valve. In Appendix B this factor is considered in detail and in one case it was found that, for a particular valve with a given length of external circuit, changing  $Z_0$  from 200 ohms to 60 ohms reduced the wavelength of operation from 85 to 52 cm.

The most convenient method of achieving low  $Z_0$  is to use a concentric line. If full advantage is to be gained then the electrode leads must also form part of the line. If the electrodes themselves are cylindrical then they too may be integral parts of the line. The great advantage to be gained from this arrangement can be seen from Fig.6. which shows two

two triodes and their oscillatory circuits for a wavelength of 90 cm. On the right is a DET 12 with a short circuiting strip of copper between the anode and grid terminals. On the left is an E1029 with the same electrode sizes and capacitances as the DET 12 but with the anode and grid and their leads as integral parts of a concentric line. The anode lead is formed by eight wires in a circular seal with a concentric grid lead. The characteristic impedance of the line in this case is about 60 ohms.

Even though the anode and grid electrodes and their leads form smooth continuous parts of the line a full quarter wavelength circuit is never obtained. The anode-cathode and grid-cathode capacitances are in series across the end of the line and have a shortening effect. It is therefore important to keep the characteristic impedance low if the maximum frequency of operation is to be obtained. In some cases it is possible to operate with  $\frac{3\lambda}{4}$ ,  $\frac{5\lambda}{4}$  or greater line lengths since these give the same reactance but it is necessary in these cases to take steps to ensure that the valve does not oscillate on a lower frequency

frequency corresponding to a  $\frac{1}{4}$  wavelength circuit (see Sect.3,11b).

The condition of low characteristic impedance may seem to conflict with the need for minimum losses in the resonator. However, the incidental losses, electronic and otherwise, in the valve are usually greater than the resistive losses in the resonator. Loss of output arising from low characteristic impedance has never been detected. Some circuits have been used with an impedance as low as 10 ohms.

After the author had started on the above work he learned that Mouromtseff and Noble had described in 1932 a water cooled valve with the anode and grid electrodes built into a concentric transmission line (Ref.4). This work had been done at a wavelength of 3 metres but nothing further seemed to come of it, probably because the significance of the value of the characteristic impedance was missed.

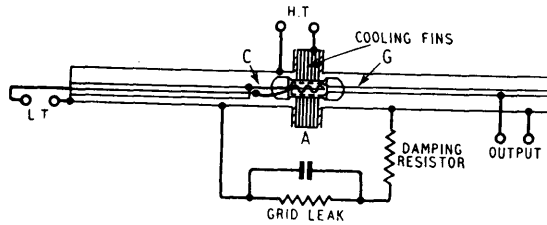

Fig.7. Common-anode Earthed-anode Oscillator  
as used with the Micropup and its family.

### 2.iii. THE 'MICROPUP'

The E1029 valve was difficult to make on account of the eight wire ring seal with the concentric grid lead. In addition there were still some 2 to 3 cm. of lead length between the electrodes and the external connections to them. The desirability of having either the anode or grid at earth potential was established in Section 2,i and this was achieved practically in the E1046 or 'Micropup' as it was usually called. (The development of water cooled valves proceeded from the small to the large until the process was reversed in the CAT 15 which was designed in the early thirties for higher frequencies. This valve was known as the 'Pup'. When the E1046 was evolved it had a certain family resemblance to the water cooled valves. As it was so small it was christened the 'Micropup').

The E1046 is shown in the photograph in Fig.1 and in the circuit in Fig.7. It has an external copper anode in the form of a cylinder with the ends feather-edged and slightly flared for the glass to metal seal. The diameter of the cylinder is 1.5 cm. The grid is a cylindrical spiral of molybdenum wire and has

has a diameter of 5 mm. The cathode is a cylindrical spiral of thoriated tungsten wire with a central supporting wire which also serves as one of the supply-leads. The cathode diameter is 3 mm. The grid is mounted on the end of a 4 mm. tungsten rod which also serves as the grid lead. The cathode leads, two tungsten wires, are taken through the envelope at the opposite end from the grid lead. Cooling fins are soldered to the anode and forced air is blown through these fins to increase the heat handling capacity. The end fins are also used for the connection of the outer conductor of the concentric line circuit (see Fig.7.).

The E1046 was first produced in 1939 and was immediately in demand for use in Naval Radar Gunnery at 50 cm. wavelength and for Aircraft Radar at 150 cm. wavelength. Peak outputs of 5 and 10 kw per pair of valves were obtained at the respective wavelengths. For the aircraft application the design was subsequently modified to the VP90 in which longer glass lengths were used to increase the voltage flash over at high altitudes.

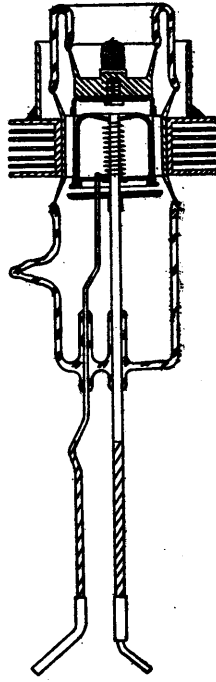

Fig.8. Sectional View of the NT99 Triode



The Navy urgently required greater output at 50 cm. wavelength. By exploiting the principle established in Section 2,ii this was achieved by increasing the radial dimensions of the E1046, thus increasing the electrode surface areas. The active length remained constant. In order to retain adequate external circuit the characteristic impedance of the leads and circuit was appropriately reduced. Several valves similar to the E1046 were developed in this way culminating in the NT99, which produced 200 kw per pair at a wavelength of 50 cm. It was also used by the R.A.F. for radar at 50 cm. (Ref.5 and 6).

The NT99 is shown in Figs. 1 and 8. It has an indirectly heated oxide coated cathode and the grid lead is a copper 'thimble' of  $\frac{7}{8}$ " diameter. The cylinder attached to the cooling fins is for making connection to the external circuit.

The NT93, another member of the series, is also shown in Fig.1.

In this series the clearance between the cathode and the grid is of the order of 1 mm. The clearance in the acorn is 0.1 mm., the door-knob 0.2 mm. and the

the DET12 1mm. Since maintaining the grid cathode clearance is one of the major problems in U.H.F. valves, it can be seen that the advances in performance were achieved without making undue demands on the valve manufacturer. The micropup series was put into large scale production both in this country and in America using unskilled female labour throughout.

The E1046 and its variants were required mainly for radar. On continuous wave operation the performance dropped off rapidly at wavelengths below 1 metre on account of electron transit time limitations and the minimum wavelength of the E1046 was 75 cm. With a view to obtaining improved performance at shorter wavelengths a one third scale model of E1046 was constructed. All the linear dimensions were reduced by a factor of three in valve type E1130 (see Fig.1.). The principles of scale modelling are discussed in detail in Appendix B and it is shown there that the minimum wavelength is reduced by the scale factor. This was confirmed by the E1130 which ceased to oscillate at a wavelength of 25 cm. and gave an output of a few watts at 30 cm. on C.W. operation.

The technique for increasing output that was used with the E1046 was also applied to the E1130. The CV55 (see Fig.1) had the same longitudinal dimensions but the radial dimensions were increased three-fold and the spiral thoriated tungsten cathode was replaced by a cylindrical oxide coated cathode.

The CV55 was used in the Army GR Radar equipment at a wavelength of 25 cm. and a peak output of 30 kw per pair was obtained. (Ref.5). It was also used by the author and his group in a number of transmitters for Radio Counter Measures on wavelengths from 40 to 100 cm. On C.W. operation a single valve gives an output of 30 W. at 50 cm. and 15 W. at 40 cm. Multivalve circuits were developed (see Section 4) giving over 100 W. at 50 cm.

2,iii,a. THE BASIC MICROPUP CIRCUIT.

Most of the radar oscillators were of the push pull type. However, the understanding of the principles of operation is simplified by considering single valve circuits first. The basic arrangement for these 'earthed' anode oscillators is shown in Fig.7. As described before, the anode and grid electrodes and leads form integral parts of a concentric line circuit. The anode, being connected to the outer conductor is at earth potential. This really means that, since the high frequency field is confined to the inside of the outer conductor, the outside of that conductor may be considered to be at earth potential. Between the cathode and earth, i.e. the anode, there is another concentric line which may be 'tuned' by adjustment of the position of the shorting bridge at the end remote from the valve. One side of the cathode is connected to the inner conductor of this line and the other side is taken through the inside of the inner conductor with suitable D.C. insulation. Sometimes a capacitor

capacitor is connected across the two cathode leads to keep them at the same potential. Circuits have also been used with separate line circuits for the two cathode leads. The slight advantage of this arrangement at the higher frequencies is offset by the complication of an extra line circuit to be tuned.

The damping resistor shown in Fig.7 is used to prevent oscillation taking place round the external grid-cathode connections. D.C. insulation between the anode and the other two electrodes is provided by capacitors, with mica insulation between the anode cooling fins and the outer conductors of the two lines.

It will be seen that the anode, in addition to being the earthed electrode, is also the electrode which is common to the two circuits. Such an arrangement is called a common-anode earthed-anode oscillator. The significance of this description is discussed in Section 3.

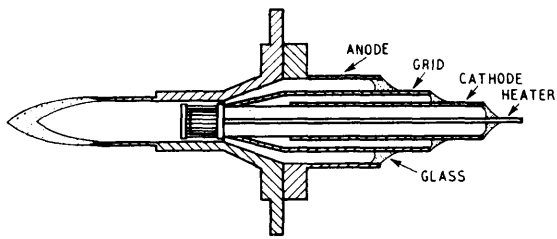

Fig.9. E.1274, 10 cm. Triode.

2.iv. THE 10 CM. TRIODE.

The main feature of the micropup and its derivatives is the integration of the anode and grid with the oscillatory circuit. If the arrangement in Fig.7 is examined it will be seen that the cathode and its leads do not fit into the circuit in the same natural manner. The spiral filament and its two leads are not particularly desirable components of a U.H.F. circuit. Those valves with an indirectly heated oxide coated cathode are rather better in this respect but there is still the problem of the heater leads (one of these is usually joined internally to the cathode).

As a further step towards achieving the ideal valve-circuit integration the E1274 was developed. This is shown in Figs. 1 and 9. The anode, grid and cathode electrodes are fixed to the ends of three concentric copper tubes, insulated from each other by glass seals. The electrodes are virtually continuations of the copper tubes. Between the oxid<sup>e</sup>coated cathode and its copper tube there is a short length of nichrome tube to conserve heating power.

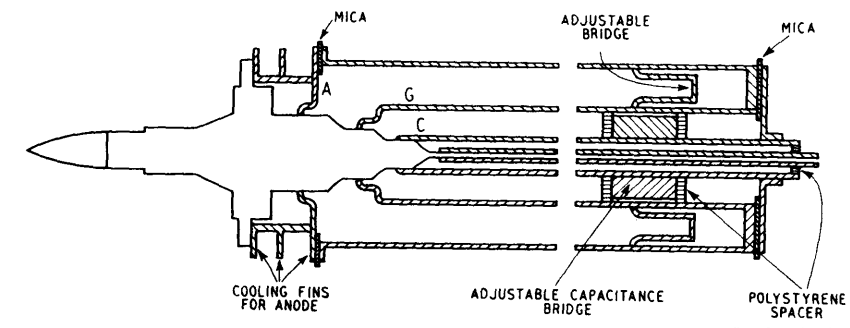

Fig.10. Common-grid Earthed-anode Circuit  
used with E1274 Triode.



One side of the heater is connected internally to the cathode. The other heater lead is a wire completely enclosed by the cathode and its lead, and so is right outside the high-frequency field. Further mechanical details of this valve are given in Appendix D.

The circuit for valve E1274 is shown in Fig.10. There are four concentric tubes which are attached to the anode, grid, cathode and heater leads. The three outer tubes form the tuned circuits with adjustable shorting bridges. The middle one of these three tubes forms the inner conductor of the anode-grid circuit and the outer conductor of the grid-cathode circuit. In this case the grid is the electrode which is common to both circuits. The anode, which is connected to the outermost tube, is the earthed electrode. The arrangement is called a common-grid earthed-anode circuit (see Section 3).

The limiting wavelength of the E1274 is set by electron transit time and it occurs at a wavelength of 9 cm. On C.W. operation the output is 1 W. at 10 cm., 5 W. at 20 cm. and 10 W. at 40 cm.

There are certain incidental features of the E1274 which are worth mentioning. The complete cylindrical symmetry makes manufacture relatively simple. The single ended construction permits easy insertion in circuits and also allows ready access to the grid-cathode system for adjustment during assembly, a most important feature where the clearance is rather less than 0.1 mm. There is no insulation between the electrodes except for the glass seals separating the copper cylinders. Direct access to the anode allows easy cooling by conduction, forced air or water. Anode dissipation does not constitute a limiting factor as in most small valves.

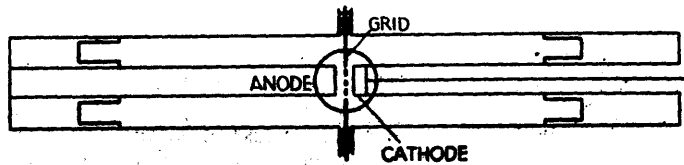

Fig.11. Common-grid Earthed-grid Oscillator.

('Grounded-grid' Circuit).

## 2.v. RECEIVING VALVES.

### 2.v.a. COMMON ANODE VALVES.

So far all the valves described are primarily power oscillators. In order to exploit the common-anode earthed-anode circuit for receiving purposes the CV 52 triode was designed by Mr.G.W.Warren in consultation with the author. The CV 52 is shown in Fig.1 and is described in detail in Appendix H. It was widely used during the war in receivers at wavelengths down to 25 cm. In 1942-43 the author made it the basis of two superheterodyne receivers which covered continuously the wavelength range from 30 to 250cm.

### 2.v.b. COMMON GRID VALVES

An independent approach to the development of receiving valve oscillators was initiated in the Laboratories of Messrs. Standard Telephones and Cables. The design (see Fig.11) was based on planar electrodes with a copper disc for the grid lead, the grid being a mesh in the centre of the disc (Ref.7.). The anode and cathode, and their respective leads were on opposite sides of the disc. Two concentric lines

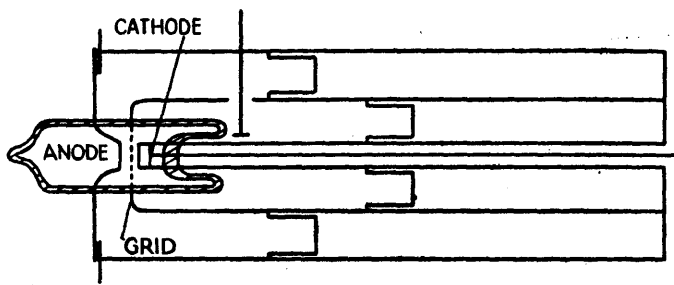

Fig.12. Common-grid Earthed-anode Oscillator  
using CV90 Triode.

lines formed the external circuits, the grid disc being attached to the outer conductors and the anode and cathode leads to the inner conductors. Such an arrangement provides a common-grid earthed-grid oscillator. It was sometimes called a 'grounded-grid' circuit.

The double-ended nature of this arrangement meant that valve changing involved dismantling the circuit. In order to overcome this disadvantage Mr. G. W. Warren developed the CV 90 triode which has another copper disc for the anode lead. (See appendix H.). This valve is used in a double concentric tube circuit (see Fig. 12) with the anode disc attached to the outer tube, and the grid tube common to the two circuits. This arrangement oscillates down to a wavelength of 10 cm. It will be noticed that the circuit makes a common-grid earthed-anode oscillator, similar to that previously described for the E1274. Thus, this alternative approach to the 10 cm. triode oscillator has led to much the same conclusion as the author's approach.

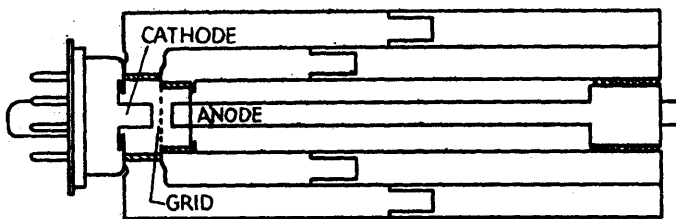

Fig.13. Common-grid Earthed-cathode Oscillator  
using 'lighthouse' Triode.

For receiving valve purposes there is little to choose between the disc triode with planar electrodes and the all-concentric arrangement with integral electrodes and leads. For power generation, however, the concentric arrangement is preferable since the active part of the anode is part of the external envelope and can be more easily cooled. In addition, at the highest frequencies the inductance of the disc is not negligible and excitation of the line circuit has proved difficult in certain cases where a voltage node occurred at the edge of the disc.

The 10 cm. triode was also achieved in the U.S.A. with a different design, commonly called the 'lighthouse', or ZP446. A planar system (see Fig.13) is used with disc leads for all the electrodes. The external circuit consists of a double concentric line, as in the other 10 cm. oscillators, but in this case the cathode is attached to the outer tube and the anode to the innermost tube. This arrangement makes a common-grid earthed-cathode oscillator. This type of circuit has the disadvantages of the other disc



disc designs and the anode, being innermost, is even more inaccessible for cooling purposes.

It will be noted that all the 10 cm. circuits are of the common grid type. The reason for this is given in Section 3.

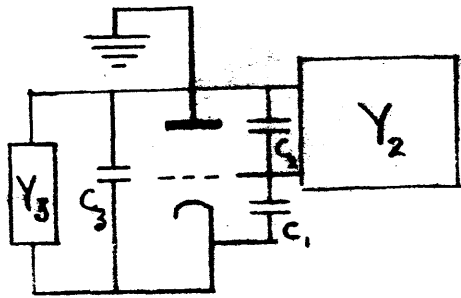

FIG. 14.

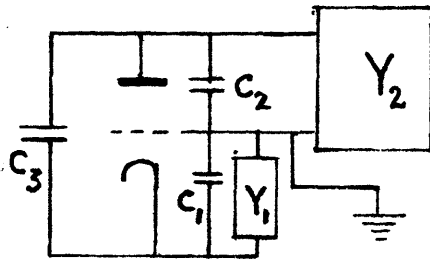

FIG. 15.

Fig.14. Common-anode Circuit.

Fig.15. Common-grid Circuit.

### 3. EXCITATION OF TRIODE OSCILLATORS.

#### 3.1. SIMPLE CONSIDERATIONS.

In Section 2,1. and in Figs. 2 and 3 the low frequency forms of the Hartley and Colpitts oscillators were given. It was seen that the excitation was controlled in a simple manner by the adjustment of a tapping point on an inductance or by varying the ratio of two capacitances. The complicated behaviour of these circuits when used at very high frequencies was also discussed. If the circuits for the new valves in Figs. 7. and 10 to 13 are examined it will be seen that they have become extremely simple again, electrically. The circuits of Figs. 7 and 10 may be redrawn as shown in Figs. 14 and 15 respectively. In Fig. 14,  $Y_2$  and  $Y_3$  represent the two line circuits between anode and grid and between anode and cathode;  $C_1$ ,  $C_2$  and  $C_3$  are the inter-electrode capacitances. Since the anode is at earth potential the electrode-earth capacitances may be included in  $C_2$  and  $C_3$ . On account of the screening action of the concentric lines there are no other stray couplings between the electrodes or circuits. If  $Y_2$  and  $C_2$  be considered to represent the main

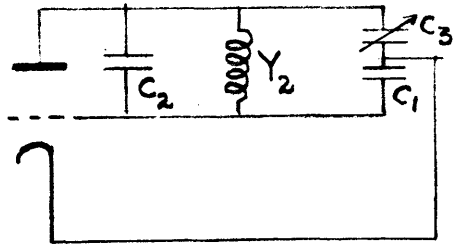

Fig.16. Common-anode Circuit.

main oscillatory circuit, then the excitation, i.e. the ratio of the grid-cathode voltage to the anode-cathode voltage, is determined by the values of  $C_1$  and the parallel combination of  $C_3$  and  $Y_3$ . The adjustable line circuit,  $Y_3$ , is a means of varying the effective value of  $C_3$ . The circuit may be redrawn as in Fig.16, which is almost the same as the L.F. Colpitts circuit of Fig.2. Thus the common-anode earthed-anode oscillator is merely a form of Colpitts circuit in which the anode-grid line forms the oscillatory circuit along with the valve capacitances, and the anode-cathode line controls the excitation.

If the common-grid circuit of Fig.15 be treated in a similar manner it will be found that exactly the same conditions hold, except that the grid-cathode line is the excitation control.

The value of the excitation depends on the ratio of the effective values of  $C_3$  and  $C_1$ . In a common anode oscillator  $C_1$ , the grid-cathode capacitance, is fixed and  $C_3$  is varied to give the desired ratio of  $C_3$  to  $C_1$ . In a common-grid oscillator  $C_3$ , the anode-cathode capacitance, is fixed and  $C_1$  is varied. In

In both cases, the series combination of  $C_1$  and  $C_3$  is in parallel with  $C_2$  and so constitutes a loading capacitance across the main oscillatory circuit. Now, in most valves  $C_1$  is greater than  $C_3$ , so that the required excitation ratio may be gained in a common-grid oscillator with a smaller loading capacitance than in a common-anode oscillator. Since the charging current and therefore, also the circuit losses depend on the value of this capacitance, the common-grid oscillator has an advantage over the common-anode oscillator, particularly at the highest frequencies. It was seen in the last section that all the 10 cm. oscillators are of the common-grid type.

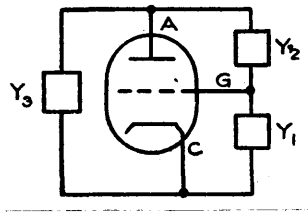

Fig.17. Triode Circuit.

3.ii. MORE EXACT ANALYSIS OF EXCITATION.

In the last section only the reactive components of the circuit impedances have been considered. A more complete analysis was carried out by the author in collaboration with Dr.E.G.James and is given in detail in Appendices C and H. In the triode circuit of Fig.17,  $Y_1$ ,  $Y_2$  and  $Y_3$  are the total admittances between the electrodes. The admittance between any two points in this network may be calculated and the condition for oscillation may be found by equating the real part of the admittance to zero. It can be shown that the total conductance between anode and grid is given by the equation

$$G_2' = G_2 + \frac{G_1 G_3 (G_1 + G_3 + g_m) + G_3 B_1^2 + G_1 B_3^2 - g_m B_1 B_3}{(G_1 + G_3 + g_m)^2 + (B_1 + B_3)^2} \quad (2)$$



where  $Y_1 = G_1 + jB_1$ , etc.

and  $g_m$  = mutual conductance of the valve.

For self oscillation,  $G_2^{-1}$  must be zero or negative. Now, all the conductances are necessarily positive and the only term which can be negative is  $-g_m B_1 B_3$ , and this can be so only if  $B_1$  and  $B_3$  are of the same sign, i.e. both must be capacitive or both inductive. Obviously, to provide an oscillatory circuit,  $B_2$  must be of opposite sign to  $B_1$  and  $B_3$ . Thus there are two possible classes of triode oscillators as shown in the table.

	$B_1$	$B_2$	$B_3$
Class I	C	L	C
Class II	L	C	L

It may be noted in passing that the Colpitts oscillator belongs to Class I and the Hartley oscillator to Class II.

### 3.ii.a. RELATIVE MERITS OF THE TWO CLASSES OF OSCILLATOR.

It can be shown that oscillators of Class I are preferable for operation at the highest frequencies.

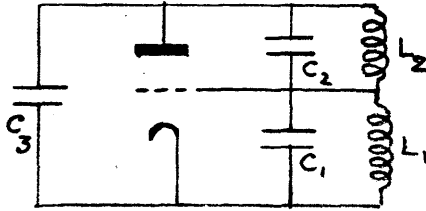

FIG. 18.

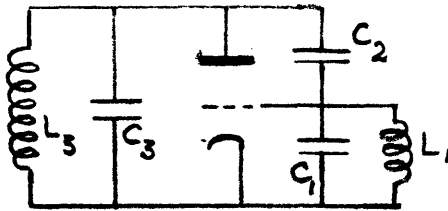

FIG. 19.

Fig.18. Class I Oscillator.

Fig.19. Class II Oscillator.

If the oscillators have two tunable circuits then for Class I one of these must be connected in parallel with the anode-grid capacitance to make  $B_2$  inductive. The other tunable circuit may be connected between grid and cathode or between anode and cathode. In the former case, the circuit may be drawn as in Fig.18 in which  $C_1$ ,  $C_2$  and  $C_3$  are the inter-electrode capacitances, and  $L_1$  and  $L_2$  are the tunable circuits. From the table it is seen that  $B_1$  must be capacitive and this capacitance in series with  $C_3$  gives a resultant less than  $C_3$ . Thus the frequency of oscillation is determined by the external inductance  $L_2$  tuned to resonance by the parallel combination of  $C_2$  and some capacitance less than  $C_3$ .

The Class II oscillator is shown in Fig.19. In this case the tunable circuits must be connected as shown in order to make  $B_1$  and  $B_3$  inductive. The inductive  $B_1$  in series with  $C_2$  gives a resultant capacitance which is greater than  $C_2$  (the combination cannot be inductive since  $B_3$  is inductive). The frequency is now determined by the external inductance  $L_3$  tuned to resonance by the parallel combination of  $C_3$

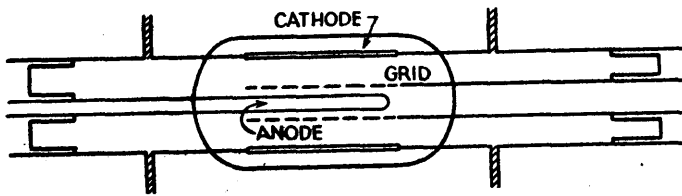

Fig.20. Common-cathode Earthed-cathode Circuit  
using an everted triode.

and a capacitance greater than  $C_2$ . If this result be compared with that at the end of the last paragraph it will be seen that, with a given external circuit, a valve will oscillate at a higher frequency if connected for Class I operation.

It may be seen from Fig.19 that a Class II oscillator must operate with the cathode as the electrode common to the two circuits. Such an arrangement can be realised at high frequencies by everting the normal arrangement of a cylindrical electrode system, i.e. by making the cathode the outermost and the anode the innermost cylinder. An experimental triode was made up in this form and it is shown diagrammatically with its circuit in Fig.20, in a common-cathode earthed-cathode oscillator. The performance of this oscillator confirmed the theory given above. For a given wavelength, the circuits were much smaller than for valves with similar capacitances in Class I circuits.

Thus, in general, successful triode oscillators for V.H.F. have inductance between anode and grid, and capacitance between anode and cathode and between grid and cathode.

Examination of the circuits of Figs.7, 10-13 will show that these are all Class I oscillators.

### 3.ii.b. MULTIPLE QUARTER WAVE CIRCUITS.

It has been shown in the previous sections that the two line circuits are adjusted to give the required reactance values for the operating frequency. The reactances of the lines can be obtained for any number of positions of the shorting bridges, all differing by half a wavelength. This is most useful at the highest frequencies when the lines become very short.

Oscillation may still be maintained by adding one or more half wavelengths. It is usually desirable to add a different number of half wavelengths to the two circuits, otherwise there is a tendency for oscillation to take place at a lower frequency where the line lengths are operating on their fundamental modes.



Fig.21. Push-pull Oscillator with two E1029

Triodes in a Half Wave Concentric Line Resonator.

#### 4. PUSH-PULL AND MULTIVALVE CIRCUITS.

So far only single valve circuits have been considered. Examination of the various types of 10 cm. oscillator will show that they are essentially single valve circuits. However, in many applications, particularly in power oscillators and in radar transmitters, push-pull circuits are frequently used.

The common-anode circuit of Fig.7 may readily be adapted for push-pull operation by extending the quarter wave anode-grid resonator to a half wave resonator with another valve at the other end. The original oscillator of this type, using two E1029 valves, is shown in Fig.21. The cathodes are tuned by means of the two concentric lines shown on the side of the box. The output power in this case is dissipated in two lamps tapped on to the inner conductor of the main resonator.

This type of push-pull oscillator was used with the micropup series in 50 cm. Naval Gunnery transmitters (Ref.5).

This arrangement has several disadvantages. Wavelength adjustment is difficult. Also, its open



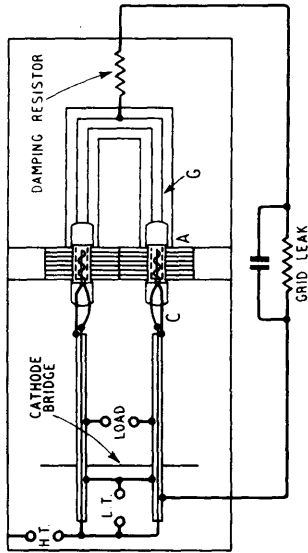

Fig.22. Common-anode Earthed-anode Oscillator  
with U-shaped Resonator.

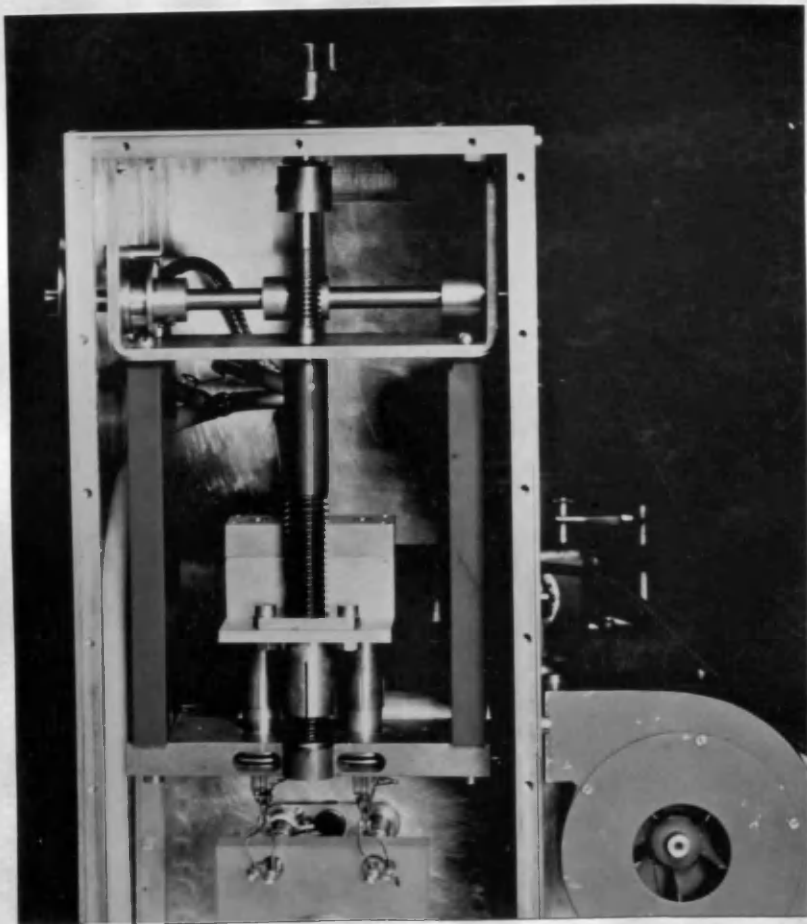

Fig.23. Common-anode Earthed-anode Push-pull  
Circuit with U-Shaped Concentric Line Resonator  
and two 6L6 Triodes.

open nature produces strong high frequency fields outside the main circuits and stray couplings can therefore affect the performance in a manner difficult to control. In Fig.21 lengths of wire may be seen attached to the ends of the main resonator. Careful adjustment of the length and position of these wires was found to improve the performance.

These disadvantages may be eliminated by bending the half-wave circuit into U-shape as shown in Fig.22 and in the photograph in Fig.23. The valves are now close together and the anodes are strapped and earthed. The cathodes are tuned by a single parallel wire line with a shorting bridge. The output may be taken conveniently from the cathode line. The oscillator in Fig.23 uses two E1130's and the conductors in the anode-grid line are made of sections of telescopic tubing so that the wavelength may be adjusted. The circuit shown operated from 40 to 60 cm.

In order to get the valves closer together some of the later E1130's and the CV55's were made with eccentric cooling blocks fitted to the anodes (see Fig.1). These blocks are firmly attached to a thick copper plate

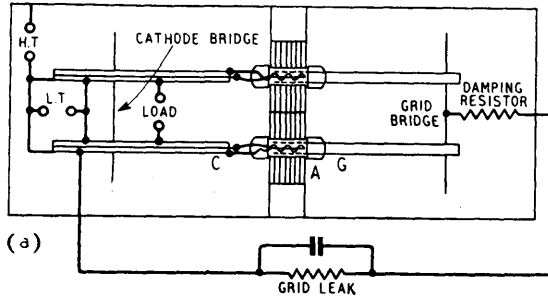

Fig. 24.

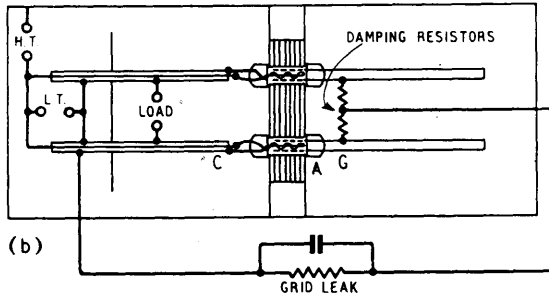

Fig. 25.

Fig.24. Common-anode Earthed-anode Push-pull Oscillator with Quarter Wave Parallel Wire Resonator.

Fig.25. Common-anode Earthed-anode Push-pull Oscillator with Open-ended Half Wave Resonator.

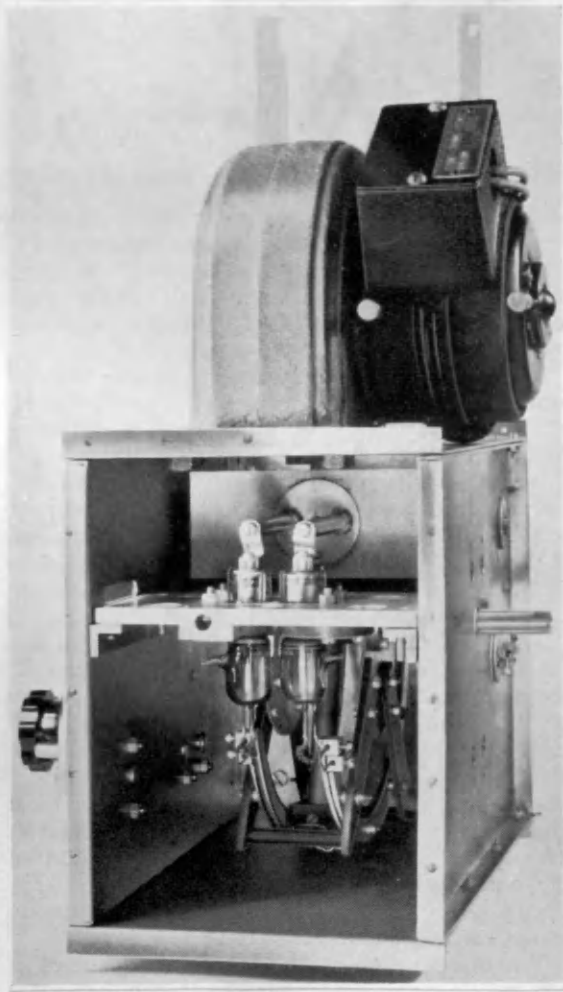

Fig.26. Common-anode Earthed-anode Push-pull Oscillator  
for a Wavelength of 60 cm., using two CV55 Triodes.

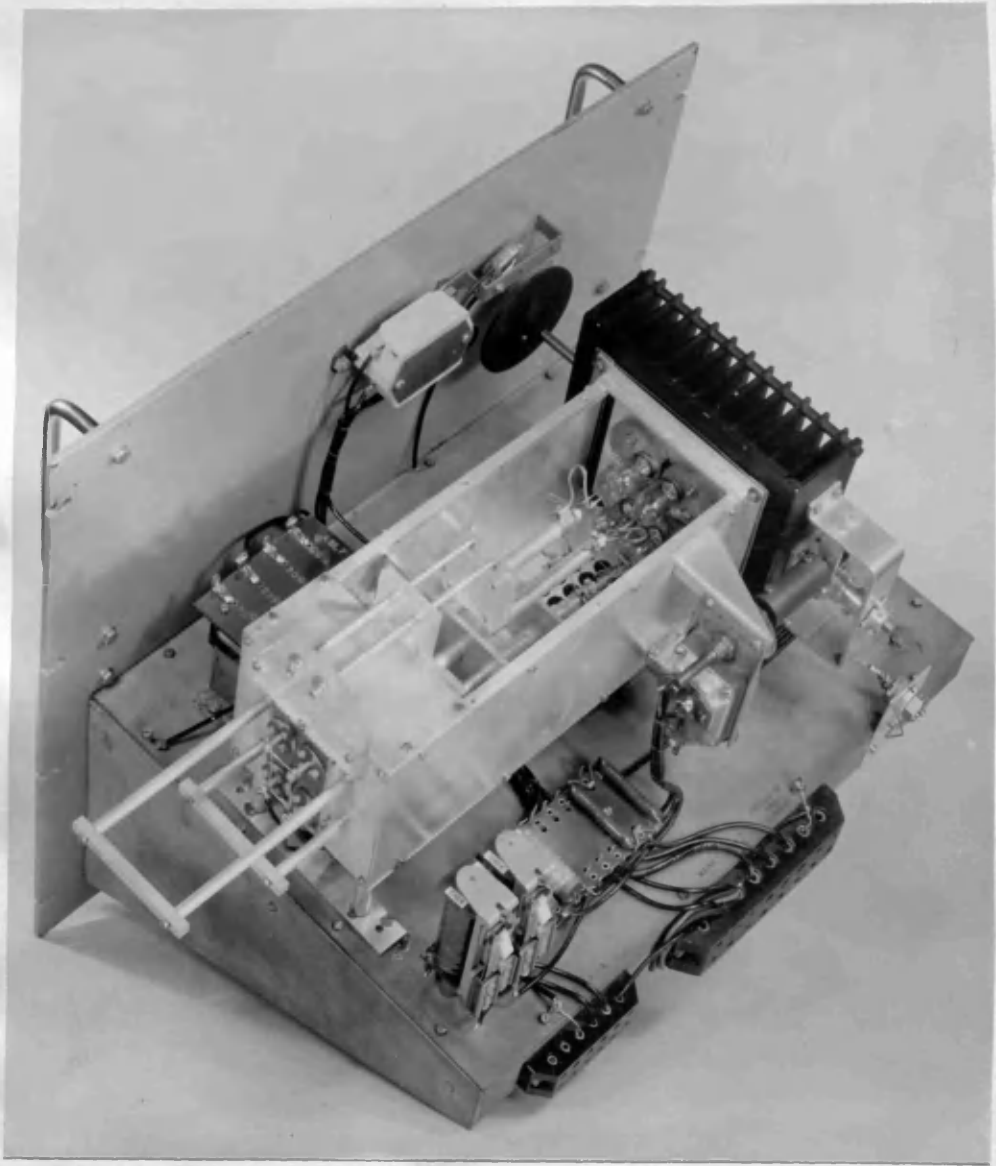

Fig.27. Four-valve parallel Push-pull Oscillator  
with four CV55 Triodes.

plate which acts as the H.F. earth and also increases the cooling surface.

Where operation at the highest frequencies is not required the concentric anode-grid line may be replaced by a parallel wire line attached to the grids as shown in Figs. 24 and 25. The open-ended line, shown in Fig. 25, is used for higher frequencies. A practical oscillator using 2 CV 55's is shown in Fig. 26. This oscillator, which is set for a wavelength of 60 cm. in the photograph, can operate from 40 to 100 cm. with output of 20-50 watts. The cathode circuit is in the form of an arc to give longer tuning range. The output is taken to a co-axial feeder by means of a loop coupled to the cathode circuit near the shorting bridge.

A four valve parallel push-pull oscillator has also been used with CV 55's giving an output of 100 W. at 50-60 cm. A photograph showing the valves and the cathode circuits is given in Fig. 27. The grid circuits, not seen in the photograph, consist of two parallel wire lines close together. The oscillators of Figs. 26 and 27 were designed by the author for Radio Counter Measures.

Further particulars of push-pull and multi-valve circuits are given in Appendices D, F and G.



PART III

Amplifiers.

## 5. AMPLIFIERS.

### 5.1. COMMON-GRID AMPLIFIERS.

In Section 3, the conditions for self oscillation was established and it was shown that  $B_1$  and  $B_3$  must be of the same sign. It can also be seen from equation (2) of that section that the product  $B_1 B_3$  must be greater than a certain value for oscillation to take place.

In the common-anode type of circuit  $B_1 (= \omega C_1)$  is fixed and  $B_3$  is variable. In the common-grid circuit  $B_3 (= \omega C_3)$  is fixed and  $B_1$  is varied. Now,  $C_1$  is the grid-cathode capacitance and this must have an appreciable value in any valve.  $C_3$ , the anode-cathode capacitance, may be made very small by having the grid act as an effective screen between the anode and cathode, as in a valve with a high amplification factor. Thus a high  $\mu$  common-grid circuit may be used as a stable amplifier. This type of amplifier has been known for some time (Ref.8) and has been called a series amplifier, an inverted amplifier or a grounded grid amplifier. During the war Messrs. Standard Telephones and Cables developed successfully the CV16 and other valves, as amplifiers for receivers for wavelengths of 50 cm. and

and under (Ref.7). Further valves for this type of operation in receivers and transmitters were developed by the author's colleagues, Messrs. Bell, James and Warren and these are described in Appendix H.

In a common-grid amplifier the output current flows through the input circuit and, as a result, there is a large amount of negative feed-back. One effect of this is a very low input impedance of the order of the reciprocal of the valve mutual conductance. In some applications this is advantageous. The tuning of the input circuit is not critical; indeed, in some cases an untuned input circuit may be used, which is convenient if a wide frequency band has to be covered.

Besides these advantages there are several disadvantages, particularly in power amplifiers. The low input impedance involves greater driving power. Some of this power appears in the amplifier output and is not lost. However, in the case of modulated power amplifiers this effect necessitates modulation of the driver as well as the final amplifier.

The common-grid amplifier has not proved very successful as a frequency multiplier. Here, large

large driving voltage is essential for efficient performance and the low input impedance is a real disadvantage.

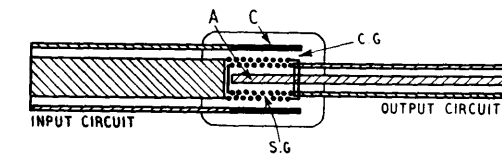

Fig.28. Diagram showing the Principle of the  
Everted Tetrode and its Circuit for use as a  
U.H.F. Amplifier.

### 5.11. EVERTED TRIODES AND TETRODES.

For power amplification and frequency multiplication at low frequencies, the familiar common cathode circuit is used, the input being applied between grid and cathode and the output being taken between anode and cathode.

There are considerable difficulties in using common cathode amplifiers with the line circuits which are so desirable for very high frequencies. These difficulties can be overcome if the usual cylindrical arrangement of the electrodes is everted so that the cathode is on the outside and the anode is innermost. Both triodes and tetrodes have been constructed in this way (see Appendices D and E). It has already been mentioned (Section 3) that a triode of this type is not suitable as a self-oscillator. Its possibilities for frequency multiplication have still to be investigated.

The everted tetrode offers particular attractions for amplification at very high frequencies, as can be seen from Fig. 28, which shows symbolically a tetrode amplifier with concentric line circuits. The cathode

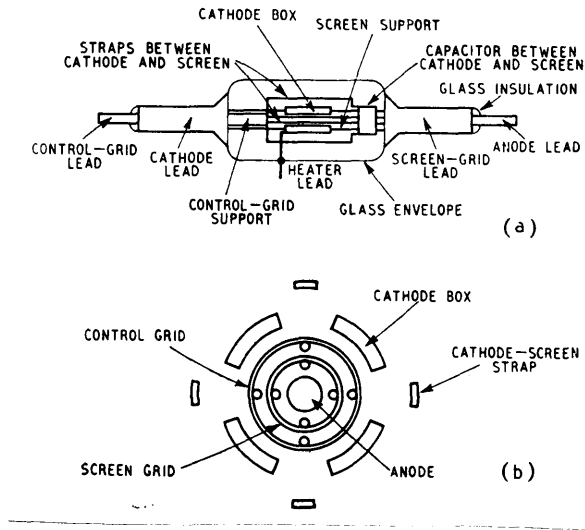

Fig.29. (a) The Everted Tetrode.

(b) Enlarged Cross-sectional view of (a).

cathode and control grid leads are taken out at one end of the valve and form integral parts of the concentric line input circuit. The screen grid and the anode similarly fit into the output circuit at the other end of the valve. The cathode and the screen grid, the two 'earthy' electrodes, are the outer members of the two lines.

A practical design of an everted tetrode is shown in Figs. 1 and 29. This tetrode, which was developed in 1939, gave appreciable gain as a receiving amplifier at 50 cm. and, as far as is known, was the first valve to give amplification at this wavelength. The subsequent introduction of the common-grid triode removed the urgency which was attached to this development. Now that the limitations of the common-grid amplifier are appreciated, it is believed that the everted tetrode could be developed to play an important part in the field of U.H.F. amplification, particularly at high power levels and for frequency multiplication. For the latter purpose everted triodes might also be used.

On the score of electron transit time effects



effects tetrodes have an advantage over triodes for Class C operation. During the passage of the current pulse the screen potential does not drop to a low value and so the transit times are less than in a triode where the anode potential drops very considerably.

For radar applications, where mean anode dissipation is low and large cathode emission is required, everted valves have the advantage that the cathode is the electrode with greatest area.

PART IV

U.H.F. Electronics

## 6. U.H.F. ELECTRONICS.

### 6.1. INTRODUCTION.

In ordinary negative grid valves as used at low frequencies the time of flight of an electron between two electrodes is usually of the order of  $10^{-9}$  sec. At low frequencies this time is so small in comparison with the alternating period that during its transit the electron is in a steady field and for most purposes the electronic behaviour can be determined from static characteristics. However,  $10^{-9}$  sec. is equal to one period of oscillation at a wavelength of 30 cm., so that a complete cycle of field variation would occur during such a transit time. At wavelengths much longer than this there would still be an appreciable change in field during the electron's transit.

In 1928, W. E. Benham (Ref.9) published the first paper on the behaviour of valves at frequencies high enough for the electron transit time to be an appreciable fraction of the period. There followed a number of theoretical papers on this subject by Benham, Llewellyn, North and others. (Ref.10 to 15). Most of these papers are highly mathematical and,

and, although simplifying assumptions were made, the results are of a complicated nature and it is difficult to get a physical picture of the effects. Sloane and James (Ref.15) made a useful contribution to the physical interpretation of transit time phenomena by presenting the results in pictorial form.

In practically all of the papers it was assumed that the alternating voltages are small in comparison with the steady voltages, so that the results are not applicable to power oscillators or amplifiers. An approach to the large signal problem has been made by Wang (Ref.16). The author has investigated two limiting cases of transit time effects in power oscillators, and these are given in Sections 6,iv and 6,v. In Section 6,ii a special case of transit time effects is investigated in a manner which gives a physical picture of the electron behaviour. The results are used to illustrate some of the general principles of U.H.F. electronics.

The author, in collaboration with Mr.G.W.Warren, has also treated the high frequency behaviour of electrons in beam deflection valves, in a manner which

which concentrates on the basic physical principles. Although it is rather outside the scope of this thesis the approach is of interest for general transit time problems and the work is given in Appendix J. The method of determining the input resistance of the deflecting system is of special interest.

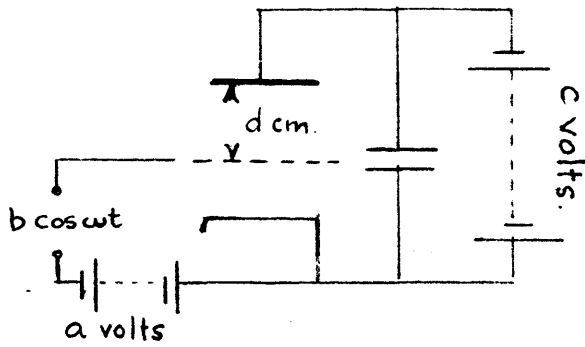

Fig.30. Circuit used for investigating the Electron Pump Effect.

### 6.11. ELECTRON PUMP EFFECT AT HIGH FREQUENCIES.

In 1936, while the author was working with a triode power amplifier at frequencies in the neighbourhood of 150 Mc/s it was noted that, when the driving power was applied to the grid, quite large currents were indicated on the anode D.C. Ammeter, even when the anode circuit was untuned and the anode potential was zero or even negative with respect to the cathode. This meant that electrons were reaching the anode although the anode potential was appreciably lower than the cathode potential. The negative voltage required to cut off the anode current was found to increase with frequency. This effect was suspected of being a high frequency electronic phenomenon and it was analysed in a way which gave a simple physical picture of the electron behaviour. The analysis is included here since it illustrates some of the main effects of electron transit times.

The circuit is given in Fig.30, which represents a plane parallel triode with grid and anode potentials as follows :-

$$e_g = a + b \cos \omega t$$

$$e_a = c.$$

If  $d$  is the distance between grid and anode and if space charge is neglected, the field strength in the grid-anode space is

$$\frac{c - a - b \cos \omega t}{d} \quad \text{volts/cm.}$$

The equation of motion of an electron is

$$k m \frac{d^2 x}{dt^2} = \frac{e}{d} (c - a - b \cos \omega t)$$

where  $x$  is the distance from the grid,  $k = 10^{-7}$  and  $e$  and  $m$  have their usual meanings.



This equation may be written as

$$\frac{d^2x}{dt^2} = A + B \cos \omega t$$

where  $A = \frac{(c-a)e}{hmd}$  ,  $B = -\frac{eb}{hmd}$

Integrating twice gives

$$\frac{dx}{dt} = v_1 + A(t-t_1) + \frac{B}{\omega} (\sin \omega t - \sin \omega t_1) \quad \text{--- (3)}$$

and

$$x = v_1(t-t_1) - \frac{A}{2}(t-t_1)^2 - \frac{B}{\omega}(t-t_1) \sin \omega t \\ - \frac{B}{\omega^2} (\cos \omega t - \cos \omega t_1) \quad \text{--- (4)}$$

where  $v_1$  and  $t_1$  are the velocity and time when  $x = 0$ . The velocity and position of an electron in the grid-anode space at any instant can be calculated from equations (3) and (4), provided  $v_1$  and  $t_1$  are known. These quantities can be determined approximately from the conditions in the cathode-grid space (see

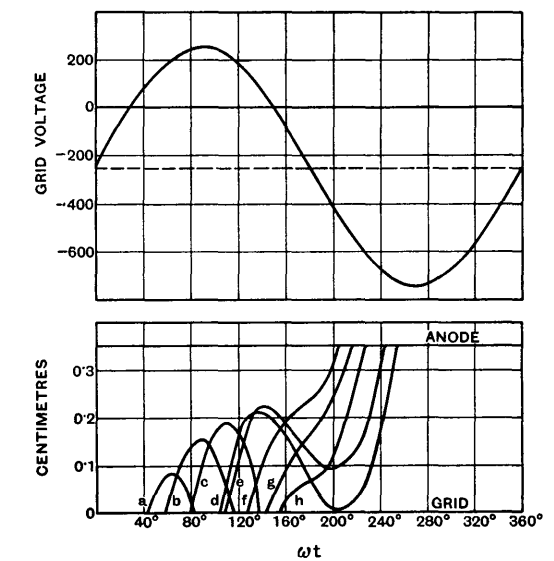

Fig.31. Electron paths in the grid-anode space.  
 $\omega t$  is phased with the Grid Voltage which is  
shown above.

(see Appendix A).

The actual paths have been calculated for a number of electrons using the following values of the constants:-  $a = -250$  volts,  $b = 500$  volts,  $c = -200$  volts,  $d = 0.35$  cm. and  $\omega = 1.26 \times 10^9$  (i.e. a wavelength of 1.5 m.) Under these conditions, electrons leave the filament during one third of the cycle, from  $\omega t = 30^\circ$  to  $\omega t = 150^\circ$ . (See Fig 31).

The curve a corresponds to an electron arriving at the grid at  $\omega t = 44^\circ$ . Its momentum carries it through but the retarding field soon brings it to rest and then back to the grid. The same applies to b and c; in these cases, the velocity at the grid is greater and the electrons travel further before being turned back. In d the electron penetrates a distance of about 2mm, then reverses. However, at  $\omega t = 150^\circ$  the grid potential becomes negative, and at  $\omega t = 175^\circ$ , becomes more negative than the anode, so that the field changes direction and the acceleration is towards the anode. The electron's flight to the grid is slowed up and at  $\omega t = 204^\circ$  it is brought to rest before reaching the grid. It then

then travels over to the anode which it reaches at  $\omega t = 254^\circ$ . The curves e, f, g and h show the paths of four later electrons which all reach the anode. All these curves show a point of inflection at  $\omega t = 175^\circ$ , the time when the field reverses.

Although a number of simplifying assumptions have been made above, some experimental verification of the theory has been obtained (See Appendix A).

6,iii. GENERAL TRANSIT TIME EFFECTS.

Certain general effects of the electron transit time can be established from the particular problem dealt with in the previous section. Firstly, when the high frequency field changes, the electron acceleration changes instantaneously with the field. Owing to the inertia of the electrons, the velocity and displacement lag behind the field. As a result, the gain in the electron's kinetic energy does not equal its loss of potential energy. The electron following path a in Fig. 51 reaches the grid at  $\omega t = 80^\circ$  when the grid potential is nearly 250 volts. During its transit the grid potential has changed from 150 to 250 volts and so the electron ultimately reaches the grid with a velocity considerably less than that corresponding to the grid potential at the time of arrival. On the other hand, the electron following path d has zero kinetic energy at time  $\omega t = 204^\circ$  and is then close to the grid which is at a potential of -400 volts. This means that the kinetic energy exceeds the potential energy by 400 electron volts. This same electron finally reaches the anode (-200 volts) with a considerable velocity. (The

(The slope of the curve is a measure of the velocity). The excess energy of this electron has been acquired at the expense of the source of the alternating field. Similarly, electron a has given energy to the alternating field. If, on the average over all the electrons, there is an excess of energy taken from the field then this constitutes a load on the source and power is consumed. The input damping in high frequency tetrode and pentode amplifiers (See Refs. 12 and 13) arises in this way. The excess energy of the electrons is ultimately dissipated as heat at the collecting electrode.

It is possible under certain conditions to have, on balance, energy given to the field at the expense of the kinetic energy of the electrons. Then the valve acts as a source of power and may generate oscillations, where the mechanism is purely electronic. There must of course be some source, such as a battery, to supply the kinetic energy to the electrons. Llewellyn and Bowen have produced oscillations from diodes by this means (Ref.17).

Another important electronic effect is

is illustrated by the curves in Fig. 51. Not only do the electrons lag behind the field but also there may be considerable spread in transit time caused by some of the electrons, such as d or e, having excessively long paths.

The example considered, with the alternating grid voltage as the main control of current flow during a part of the cycle, is very similar to the Class C oscillator or amplifier. The main difference is that the anode in Class C operation is at a positive potential and some of the electrons flow on to the anode, thus making up the pulse of anode current which flows once per cycle. There are still some electrons which are collected by the grid as in the example above. Near the end of the conduction period some of these electrons, which at low frequencies would flow to the grid, will be reversed and will reach the anode some time later. In addition some of the electrons during the earlier part of the flow give energy to the field and as a result some of them which should pass on to the anode will be collected by the grid. The overall result is to produce a broadening of the anode



Fig.32. The Anode Current Pulse in a Class C  
Oscillator or Amplifier. The full and  
broken lines show the pulse shape at L.F.  
and H.F. respectively.



anode current pulse as shown by the broken line in Fig.32. The full line shows the shape of the pulse at low frequencies. The broader pulse will result in reduced output and low efficiency.

For the normal operation of negative grid valves transit time effects are harmful. Electronic damping and spread of transit times are causes of energy loss in both amplifiers and oscillators. The phase delay in the anode current is an additional source of loss in the self oscillator, as shown in the next section.

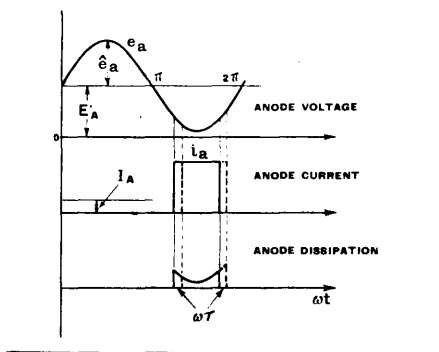

Fig.33. Effect of Transit Time on the Anode Current and the Anode Dissipation in a Class C Oscillator.

#### 6.iv. ONSET OF TRANSIT TIME EFFECTS IN THE POWER OSCILLATOR

As mentioned in Section 6,i the large signal theory of high frequency electronics has not been developed on account of its complexity. Special limiting cases can be handled and in this section the effects of transit time on a Class C oscillator are considered at frequencies where the effects are just beginning to be noticeable.

In a Class C oscillator operating at low frequencies the electron current is in phase with the grid voltage and in antiphase with the anode voltage. At higher frequencies when the transit time is appreciable then these phase relationships still apply approximately to the electrons leaving the cathode but, owing to the finite transit time, the electrons arrive at the anode when it has passed its minimum value and the phase difference is now greater than  $\pi$ . As a result there is increased power dissipation at the anode. Fig.33 shows these effects in a simplified form. The full lines represent the anode voltage, anode current and anode dissipation at low frequencies, and the broken lines represent the ~~same quantities~~ at  
*current and dissipation*

at high frequencies.

The anode current is, for simplicity, assumed to be a rectangular pulse which lasts for a quarter of a period. The same wave shape is assumed for both the L.F. and H.F. cases. Actually, as was shown in the previous section, the anode current pulse is broadened by the electron transit times. However in this section only the effect of the phase delay is considered.

For the low frequency case, the instantaneous power loss at the anode is given by

$$e_a i_a = (E_a + \hat{e}_a \sin \omega t) i_a$$

and the mean power loss is

$$\begin{aligned} P_1 &= \frac{1}{2\pi} \int_{\frac{5\pi}{4}}^{\frac{7\pi}{4}} (E_a + \hat{e}_a \sin \omega t) i_a d(\omega t) \\ &= \frac{E_a i_a}{4} - \frac{\hat{e}_a i_a}{\pi\sqrt{2}} \end{aligned}$$

When the transit time becomes significant, the mean power loss is

$$P_2 = \frac{1}{2\pi} \int_{\frac{5\pi}{4} + \omega\tau}^{\frac{7\pi}{4} + \omega\tau} (E_a + \hat{e}_a \sin \omega t) i_a d(\omega t) \dots (5)$$

$$= \frac{E_a i_a}{4} - \frac{\hat{e}_a i_a}{\pi \sqrt{2}} \cos \omega \tau$$

Since  $\omega\tau$  is assumed to be small,

$$P_2 = \frac{E_a i_a}{4} - \frac{\hat{e}_a i_a}{\pi \sqrt{2}} + \frac{\hat{e}_a i_a \omega^2 \tau^2}{2\pi \sqrt{2}}$$

The input power is the same in each case, namely

$$P_o = E_a I_a$$

and the efficiencies are

$$\eta_1 = \frac{P_o - P_1}{P_o} \quad \text{and} \quad \eta_2 = \frac{P_o - P_2}{P_o}$$

Therefore

$$\eta_1 - \eta_2 = \frac{\hat{e}_a i_a \omega^2 \tau^2}{2\pi\sqrt{2} P_c} .$$

But

$$I_a = \frac{i_a}{4} ,$$

therefore

$$\eta_1 - \eta_2 = \frac{\sqrt{2}}{\pi} \frac{\hat{e}_a}{E_a} \omega^2 \tau^2 \quad (6)$$

Thus, the decrease in efficiency is proportional to the square of the frequency, to the square of the transit time and to the ratio of the peak alternating voltage to the mean voltage of the anode.

Several assumptions have been made in deriving equation (6). Some of these are :-

- (i) The anode current was assumed to be a rectangular pulse which lasted for quarter of a period.

- (i) period. Although this is a very rough representation of the true pulse shape, the error introduced will not be large, since the effect of the transit time has been found by taking the difference of two results which both err in the same way. A different wave form would give a similar equation to (6) but with different constant terms.
- (ii) The spread of the anode current pulse due to transit time has been ignored.
- (iii) In equation (5) it has been assumed that the instantaneous energy loss at the anode corresponds to the instantaneous value of the anode potential. From Section 6,iii it is known that this assumption is not true. However the error during the first half of the pulse is of opposite sign to that of the second half and these will cancel each other to a large extent.
- (iv) Transit time loss in the grid circuit has been ignored.
- (v) All the electrons have been assumed to have the

(v) the same transit time. Most of the electrons traverse the triode when the grid and anode voltages are near their turning values and are changing slowly. In addition, when one of these voltages is increasing the other is decreasing. Thus the assumption of equal transit times cannot be far wrong.

As a result of all these assumptions high accuracy cannot be claimed for equation (6) but it at least gives a measure of the effect of transit time on the efficiency of an oscillator.

In most Class C oscillators working at high efficiency

$$\frac{\hat{I}_a}{E_a} \doteq 0.9$$

so that

$$\eta_1 - \eta_2 \doteq 0.4 \omega^2 \tau^2 \quad (7)$$



From equation (7) it can be found that the efficiency has dropped by 10% from its maximum value when the transit time is equal to 1/12 of the period.

The application of this theory to actual oscillators is discussed in Appendix B. The agreement in some cases was good, and, in general, equation (7) may be used as a basis of valve design. For this purpose it can be expressed in terms of valve clearances and voltages in the following way. In most Class C oscillators, the maximum value of the grid voltage is approximately equal to the minimum anode voltage i.e.

$$e_{g_{\max}} = e_{a_{\min}} = \frac{E_a}{10}$$

The transit time in the space charge limited cathode-grid space can be shown to be three times the transit time that would occur if the electrons moved throughout with a velocity equal to the velocity of arrival at the grid. Thus the total transit time in the present case can be found by considering the electrons moving with uniform velocity corresponding

corresponding to a potential drop of  $\frac{E_a}{10}$  volts for a distance equal to

$$3d_{hg} + d_{ga}$$

where  $d_{kg}$  = grid-cathode clearance

and  $d_{ga}$  = grid-anode clearance

Thus the total transit time,  $\tau$ , is given by

$$\begin{aligned} \tau &= \frac{3d_{hg} + d_{ga}}{\sqrt{\frac{2e}{m} \cdot \frac{E_a}{10}}} \\ &= \frac{3d_{hg} + d_{ga}}{5.93 \times 10^7 \sqrt{\frac{E_a}{10}}} \end{aligned}$$

From (7) the wavelength at which the efficiency has dropped by 10% is given by

$$\lambda = \frac{2 \times 10^4 (3d_{kg} + d_{ga})}{\sqrt{E_a}} \text{ cm.} \quad (8)$$

This equation is now in a form that can be used for design purposes.

The drop in efficiency considered in this section applies only to power oscillators. In amplifiers with separate input and output circuits, the phase of the anode voltage can be adjusted to allow for the delay in anode current. Such an adjustment is not possible in the self oscillator since, with the types of circuit which must be used, the anode and grid voltages are closely interdependent.

In calculating the values of the transit times it is assumed that the electrode system is planar. Many of the U.H.F. triodes are cylindrical but the clearances between the electrodes are small in

in comparison with their radii, and the actual transit times differ very little from those of a planar system with the same clearances. (See Appendix B).

### 6.v. MINIMUM WAVELENGTH SET BY ELECTRON TRANSIT TIME.

Another limiting case where the transit time effects can be calculated for a power oscillator occurs at the wavelength where oscillation just ceases. At that point the alternating voltages are vanishingly small and the electron transit times depend only on the steady electrode voltages. In most self-oscillators the grid bias is obtained by means of a grid leak so that in the limiting case the applied grid voltage is zero. The transit time is determined therefore by the anode voltage  $E_a$ .

The effective grid potential is  $\frac{E_a}{\mu}$  and the cathode grid transit time,  $\tau_{kg}$ , is given by

$$\tau_{kg} = \frac{3 d_{kg}}{5.93 \times 10^7 \sqrt{\frac{E_a}{\mu}}}$$

In the grid-anode space, space charge may be neglected and the potential at any point distant  $x$

from the grid is

$$\frac{E_a}{\mu} + \left( E_a - \frac{E_a}{\mu} \right) \frac{x}{d_{ga}}$$

The corresponding velocity is

$$5.93 \times 10^7 \sqrt{E_a \left\{ \frac{1}{\mu} + \left( 1 - \frac{1}{\mu} \right) \frac{x}{d_{ga}} \right\}}$$

The grid-anode transit time,  $\tau_{ga}$ , is found by integration to be

$$\tau_{ga} = \frac{2 d_{ga}}{5.93 \times 10^7 \sqrt{E_a}} \times \frac{\sqrt{\mu}}{\sqrt{\mu} + 1}$$

The total transit time from cathode to anode,  $\tau$ , is found from

$$\begin{aligned} \tau &= \tau_{kg} + \tau_{ga} \\ &= \frac{l}{5.93 \times 10^7} \times \frac{d\mu}{dE_a} \left\{ 3d_{kg} + \frac{2d_{ga}}{\sqrt{\mu+1}} \right\} \quad (1) \end{aligned}$$

Four valves similar to the E1029 but with different electrode clearances were specially constructed to investigate equation (9) (see Appendix B.). These four valves and the micropup series were all found to cease oscillation at a wavelength where the total transit time was approximately half a period. All of these valves operated in common-anode circuits and the range of minimum wavelengths was 25 to 90 cm.

The common-grid triodes, E1274 and CV90, have limiting wavelengths where the transit time is about two-thirds of a period.

In some small valves the anode dissipation is a limiting factor. For these it is advantageous to have

have a low amplification factor since the required transit time can then be achieved with a low anode voltage. If  $\mu$  is too low the characteristics are poor and the performance suffers. In most of the successful triodes anode dissipation is not a limitation and  $\mu$  is of the order of 20 to 40. Some of the older glass envelope valves such as the door-knobs and the DET 12 have amplification factors of 10 or less.



6.vi. CATHODE EMISSION.

The need for small electron transit time imposes high demands on the emission from the cathode. The effective grid voltage must exceed a certain value to give sufficiently small transit time. In order to maintain space charge limitation at this grid voltage, the emission per sq.cm. of cathode surface must be greater than a certain amount. It can easily be shown (see Appendix C) that the emission density,  $I$ , in amps per sq.cm. is given by

$$I = \frac{3 \times 10^{-28} d f^3}{h^3} \quad (10)$$

where  $d$  = cathode-grid clearance in cm.

$f$  = frequency of oscillation

and  $k$  = ratio of the transit time to the period.

In the 10 cm. triodes the grid-cathode clearance is about 0.008 cm. If half the total transit time of two-thirds of a period occurs between cathode and grid then equation (10) shows that the emission density is

is about 1.5 amp per sq.cm. This represents about the maximum emission that can be reliably maintained with existing oxide-coated cathodes. Thus the prospect at present of reducing the wavelength of operation much below 10 cm. is limited.

It is fortunate for the success of radar that high voltage pulse modulation favours emission from oxide coated cathodes. The author's colleagues found that emission densities of 10 amps per sq.cm. could be maintained under pulsed conditions.

SUMMARY AND CONCLUSION

SUMMARY AND CONCLUSION.

Successful progress with negative grid valves for decimetre wavelengths has depended almost entirely on circuit developments. Prior to the present work the advance towards shorter wavelengths was achieved mainly by making very small valves of conventional design. The integration of the valve with its circuit, which was started with the E1029, virtually eliminated one of the two major limitations and ultimately enabled valves to be used down to a wavelength of 10 cm. At the same time, greatly improved performance was gained at longer wavelengths.

After the present work started, the old technique was taken a stage further in the double-ended door-knob (Ref.18) which gave some output at 20 cm. In this design the skills of the mechanic and glass blower were pushed to their extreme limit.

The new designs of valves and circuits are much easier to make and simpler to operate. The triode oscillator is reduced to a simple three terminal network whose behaviour can be readily analysed. It is found that all successful short wave oscillators operate with

with inductive reactance between anode and grid and with capacitive reactance between anode and cathode and between grid and cathode. Most of the oscillators have two variable circuits. The one between the anode and grid determines the frequency and the other, between anode and cathode or between grid and cathode controls the excitation.

successful

There are two main types of oscillator, which are distinguished by the electrode which is common to the two variable circuits. They are known as common-anode or common-grid oscillators. The latter have the better performance at the shortest wavelengths and include all the 10 cm. triodes. The common-anode oscillator is easily adapted for push-pull operation and most of the high power triodes for radar belong to this class.

Common-grid triodes can also be used for amplification. They have disadvantages for certain applications, and everted triodes and tetrodes have been suggested as more suitable amplifying valves which have all the features of low frequency amplifiers along with the types of circuit which are needed at decimetre

decimetre wavelengths.

The finite electron transit time causes the other major limitation to performance. It is shown in the thesis that the need for short transit time imposes a demand on cathode emission which is being used to its limit in the 10 cm. triodes.

It is also shown that common-anode oscillators reach their limit of oscillation when the total transit time from cathode to anode is half a period. In common-grid oscillators the limit occurs at two-thirds of a period.

In the self-oscillator deterioration in performance begins to be appreciable when the total transit time is about one-twelfth of a period.

Today the negative-grid valve has reached the stage where its use at wavelengths below 10 cm. is prevented by electron transit time. Electrode clearances have been reduced to less than 0.1 mm. and reduction cannot be carried much further. The only way in which the valve engineer can hope to extend the limit is to produce more efficient cathode emitters.

emitters. When this is done further limitations may appear. An incidental limitation is primary grid emission, which might become more serious with more efficient cathodes.

LIST OF REFERENCES



REFERENCES.

1. Thompson, B.J. and Rose, G.M. - Vacuum Tubes of Small Dimensions for Use at Extremely High Frequencies, Proc.I.R.E., Vol.21, p.1707, Dec.1933.
2. Fay, C.E. and Samuel, A.L. - Vacuum Tubes for Generating Frequencies above 100 Mc, Proc.I.R.E., Vol.23, p.199, March 1935.
3. Kelly, M.J. and Samuel, A.L. - Vacuum Tubes as High Frequency Oscillators, Elec.Eng. Vol.53, p.1504, Nov.1934.
4. Mourontseff, I.E. and Noble, H.V. - A New Type of Ultra-Short-Wave Oscillator, Proc.I.R.E., Vol.20, p.1328, Aug.1932.
5. Ratsey, O.L. - Radar Transmitters, Jour.I.E.E., Vol.93, Part IIIA, No.1 p.245.
6. England, T.S. - Development of Decimetre-Wave Radar Transmitters for the Royal Air Force, Jour.I.E.E., Vol.93, Part IIIA, No.6, p.1016.
7. Foster, J. - Grounded-grid Amplifier for Very Short Waves, Jour. I.E.E., Vol.93, Part IIIA, No.5, p.868.
8. Strong, C.E. - The Inverted Amplifier, Electronics, Vol.13, p.14, July 1940.

Contd.

9. Benham, W.E. - Theory of the Internal Action of Thermionic Systems at Moderately High Frequencies, Phil.Mag., p.641, March 1928.
10. Benham, W.E. - Contribution to Tube and Amplifier Theory, Proc.I.R.E., Vol.26, p.1093, Sept.1938.
11. Llewellyn, F.B. - Electron Inertia Effects, Cambridge Univ. Press, 1941.
12. North, D.O. - An Analysis of the Effects of Space Charge on Grid Impedance, Proc.I.R.E., Vol.24, p.108, Jan.1936.
13. Ferris, W.R. - Input Resistance of Vacuum Tubes as Ultra-high Frequency Amplifiers, Proc.I.R.E., Vol.24, p.82, Jan.1936.
14. Müller, J. - Elektronenschwingungen im Hochvakuum, Hochfreq. u. Electroak. Vol.41, p.156, May 1933.
15. Sloane, R.W. and James, E.G. - Transit-time Effects in Diodes in Pictorial Form, Jour.I.E.E., Vol.79, p.291, Sept.1936.
16. Wang, C.C. - Large Signal High Frequency Electronics of Thermionic Vacuum Tubes, Proc.I.R.E., Vol.29, p.200, April 1941.
17. Llewellyn, F.B. and Bowen, A.E. - The Production of Ultra-high Frequency Oscillations by Means of Diodes, Bell Sys. Tech.Jour. Vol.18, p.280, April 1939.

Contd.

18. Samuel, A.L. - A Negative Grid Triode Oscillator and Amplifier for Ultra-high Frequencies, Proc.I.R.E., Vol.25, p.1243, Oct.1937.
19. Thompson, B.J. - Review of Ultra-high Frequency Vacuum Tube Problems, R.C.A.Rev., Vol.3, p.146, Oct.1938.
20. Strutt, M.J.O. and van der Ziel, A. - The Causes for the Increase of the Admittances of Modern High Frequency Amplifier Tubes on Short Waves, Proc. I.R.E., Vol.26, p.1011, Aug.1938.
- 
-